



DEVELOPMENT OF AN ARDUINO-BASED OBSTACLE AVOIDANCE ROBOTIC SYSTEM FOR AN UNMANNED VEHICLE

Kolapo Sulaimon Alli, Moses Oluwafemi Onibonoje, Akinola S. Oluwole, Michael Adegoke Ogunlade, Anthony C. Mmonyi, Oladimeji Ayamolowo and Samuel Olushola Dada
Department of Electrical/Electronic and Computer Engineering, Afe Babalola University, Ado Ekiti, Nigeria
E-Mail: alliks@abuad.edu.ng

ABSTRACT

The use of autonomous systems in the world to perform relevant and delicate task is fast growing. However, its application in various fields cannot be over emphasized. This paper presents an obstacle detection and avoidance system for an unmanned Lawnmower. The system consists of two (Infrared and Ultrasonic) sensors, an Arduino microcontroller and a gear DC motor. The ultrasonic and infrared sensors are implemented to detect obstacles on the robot's path by sending signals to an interfaced microcontroller. The micro-controller redirects the robot to move in an alternate direction by actuating the motors in order to avoid the detected obstacle. The performance evaluation of the system indicates an accuracy of 85% and 0.15 probability of failure respectively. In conclusion, an obstacle detection circuit was successfully implemented using infrared and ultrasonic sensors modules which were placed at the front of the robot to throw both light and sound waves at any obstacle and when a reflection is received, a low output is sent to the Arduino microcontroller which interprets the output and makes the robot to stop.

Keywords: obstacle avoidance, Arduino, unmanned, infrared, robot.

INTRODUCTION

The application and complexity of mobile robots are slowly growing every day. They are gradually making their way into real world settings in different fields such as military, medical fields, space exploration, and everyday housekeeping [1]. Motion being a vital characteristic of mobile robots in obstacle avoidance and path recognition has a major impact on how people react and perceive an autonomous system. This enables an autonomous robot to be able to navigate from one place to another without human intervention. Computer vision and range sensors are primary object detection methods used in mobile robots' detection. Computer vision as an obstacle detection method is more rigorous and expensive technique than the range sensors' method. However, most commercial autonomous robots use range sensor to detect obstacles. The use of radar, infrared (IR) sensor and ultrasonic sensor for developing an obstacle detection system had started as early as the 1980's [2]. Although, after testing these technologies it was concluded that the radar technology was the most suitable for use as the other two technology options were prone to environmental constraints such as rain, ice, snow, dust and dirt. The radar approach was also a very cost effective technology both for the present and the future. [3] presented a method using a single charge-coupled device (CCD) camera in conjunction with a spherically shaped curved reflector which enables ultra-wide angle imaging. The sensors are not limited to obstacle detection. Other sensors may be used to extract different features in plants for plant characterization, allowing an autonomous robot to give the proper fertilizer in the proper amounts to different plants as explained by [4]. [5] also made use of cameras to aid navigation and obstacle detection for a robot in searching for meteorites on the Antarctic continent. [6] used stereo vision to aid in dead reckoning for planetary rovers. [7]

employed (five) CCD cameras for reconnaissance and surveillance on All-Terrain Vehicles. The major drawback of stereo vision is the need for an adequate illumination for obstacle detection. Due to this shortcoming, cameras are often used as a backup discussed in [8, 4, 9].

In [10, 11, 12, 13, 14], sonar was used for vehicle localization and navigation respectively. [15] developed an algorithm for obstacle detection and avoidance using a sonar ring placed around the robot. Unfortunately, the major drawback of sonar is that a single sensor is inadequate to acquire enough information about environment around an autonomous vehicle. Often times several rings of sonar sensors are connected together for optimum performance as presented in [16, 17, 18, 19]. This is usually cumbersome and expensive for implementation. However, despite the aforementioned limitations, sonar is still a good safety net for obstacle detection. Also, the use of vision and laser scanner for unmanned ground vehicle to avoid obstacle has been presented in [20]. Support Vector machine (SVM) has been proposed by [21] for creating local path for an unmanned ground vehicle. Also, the development of an unmanned ground vehicle system for remote-controlled surveillance has been presented by [22]. A reliability and failure tests in unmanned ground vehicle has been carried out in [23]. A study on the use of industrial robot in various industries in America has been conducted in [24, 25]. Finally, the use of ultrasonic sensor for an obstacle avoidance robot vehicle to create a clear path for locomotion has been presented in [26].

The focus of this study is placed on designing a simple, cost effective obstacle avoidance autonomous system using Two (2) pairs of heterogenous sensors and evaluate its performance.



METHODOLOGY

This section discussed the compositions of the hardware components and software implementations used for designing and constructing the project. The fabrication of the chassis and casing of the system are also discussed.

Hardware design

The system consists of Power supply unit, IR led / receiver sensor pair, Ultrasonic Sensor, Arduino Microcontroller and the Geared DC Motors as shown in Figure-1. The Arduino Uno is a microcontroller board based on the ATmega328. It consists of 14 digital input/output (I/O) pins (6 of the pins can be used as PWM outputs), 6 analogue inputs, a 16 MHz ceramic resonator, a USB connection, a power jack, an ICSP header, and a reset button. This is a preferred choice because of its power consumption and relatively cheap. Two types of sensors were used namely: the ultrasonic and infrared sensor in order to improve on sensitivity and reliability of existing systems.

The infrared sensor uses the principle of reflection of incident light ray for detection of an obstacle.

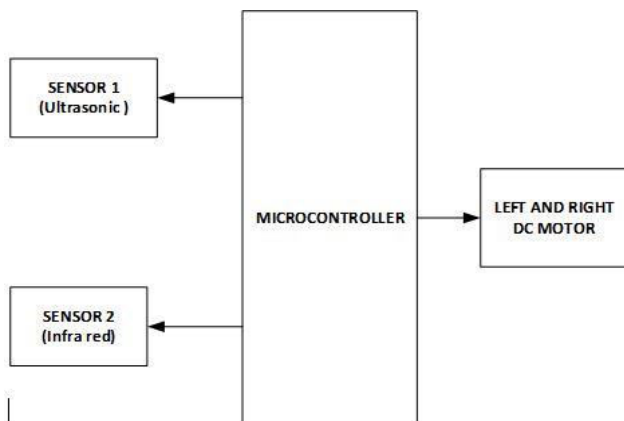

Figure-1. Block diagram of the system.

An ultrasonic HC-SR04 whose primary function is to send a ping signal at regular intervals and wait for response. Two sets of power supply were used in the system, a 9V volt battery which supply power to the microcontroller module and a 12V source regulated to 5V which was used to power the infrared and ultrasonic sensor. The circuit was designed using Proteus8.5 as shown in Figure-2.

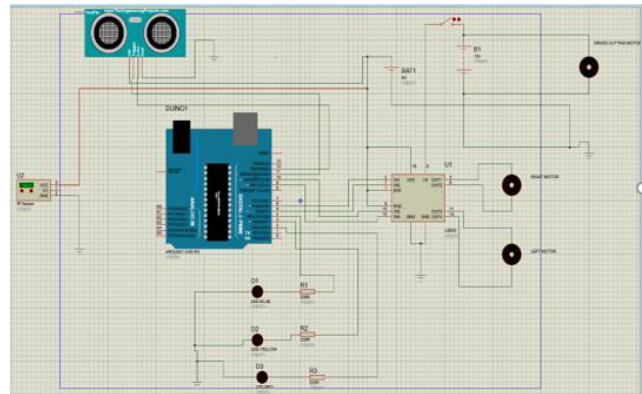

Figure-2. Schematic diagram of the system in Proteus.

Software implementation

The system was implemented in C++ using the Arduino software. Figure-3 shows the flowchart of the robot at initialization of the sensors which becomes active when the motor is actuated to move in the forward direction simultaneously. The ultrasonic transmits a sound at 37 KHz and then waits to receive a corresponding echo from the sent signal. The system calculates the distance ahead of the obstacle once the time is estimated ahead given by:

$$D = \frac{t_{IN} \times V}{2} \quad (1)$$

where

D Distance between the sensor and the detected object.

t_{IN} Time Between transmitted and received reflected wave.

V Ultrasonic wave propagation speed in air at normal speed 344m/s.

As illustrated in Figure-3, if the distance ahead is less than 40 m, the controller prompts the motor to turn at 90-degree angle and move in the forward direction. The Infrared sensor sends out its signal once the ultrasonic part is clear and if it also detects an obstacle, motor is prompted to rotate in an anticlockwise direction for a reverse of the car to take place, it then turns to the right and continue in the forward direction as shown in Figure-4.

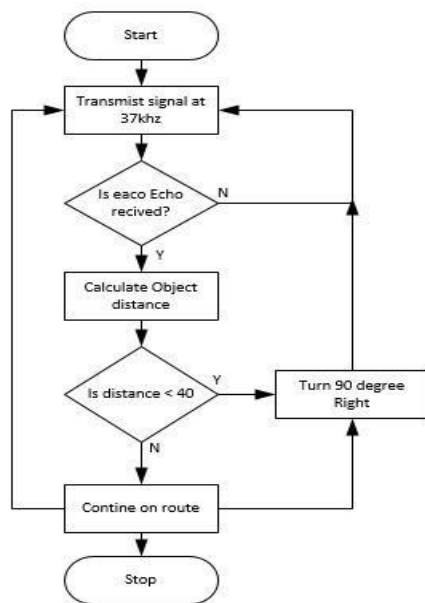

Figure-3. Obstacle detection and avoidance using ultrasonic sensor.

DATA COLLECTION

Data collection was possible through the use of two different sensors which were placed to read data from the environment and send digital information to the microcontroller which then reads the data and carries out the necessary instructions as designed by the users. The sensors for collecting data include the IR sensor module and the Ultrasonic sensor.

The IR sensor module consists of an IR emitter and an IR receiver placed side by side and when a reflection is received the IR receiver sends a low output and a high output when an input signal is received. Hence, a pair of the IR sensor module is placed at the bottom of the frame work to face the ground and monitor just above the grass level for any obstacle on the path that the robot should be following, an IR sensor module is also placed at an opening at the front of the robot as an obstacle detection to identify when an obstacle is on the path.

A single Ultrasonic Sensor is also placed just on top of the robot high enough to follow the pavement of the lawn to avoid hitting the lawn, the microcontroller reads the distance of the pavement from the ultrasonic sensor and turns right and left after each time it reaches the end of the wall.

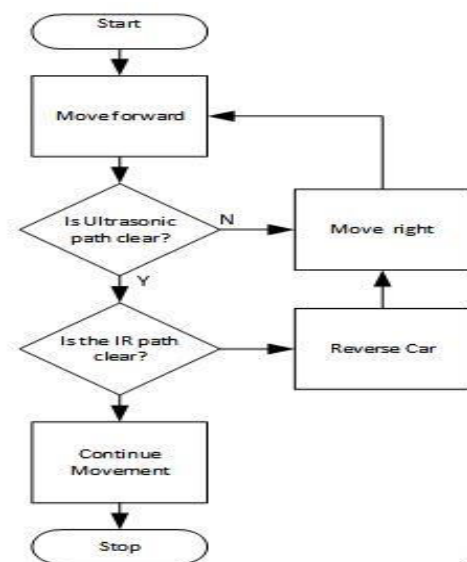

Figure-4. Flow chart of the developed system.

SIGNAL PROCESSING

The outputs from all sensors used on the board are all connected to the Arduino microcontroller board. Since the data obtained from the sensors are digital i.e. the IR sensor module sends a high bit signal when no reflection is received. These are the input devices used in the vehicle avoidance system and since they are digital, they are connected to the digital pins of the Arduino. On receiving these data from the sensors, the Arduino microcontroller is able to decide on what decisions to make with the data using a set of instructions that have been put into the memory. The output devices in control by the Arduino microcontroller are dc motors to control direction of car and for the blade cutting the grass.

Chassis design and fabrication

A sketch of the car was designed using Autodesk inventor software shown in Figure-5. During this design process, various modifications were made to the sketch and errors were corrected to enable proper meshing of parts and simulation.

The design was fabricated using Aluminium plate with a thickness of 1mm. The robotic frame work is triangular shape with two rear wheels and a front wheel. The rear wheels are made up of plastics, which are attached directly to the servo motor.

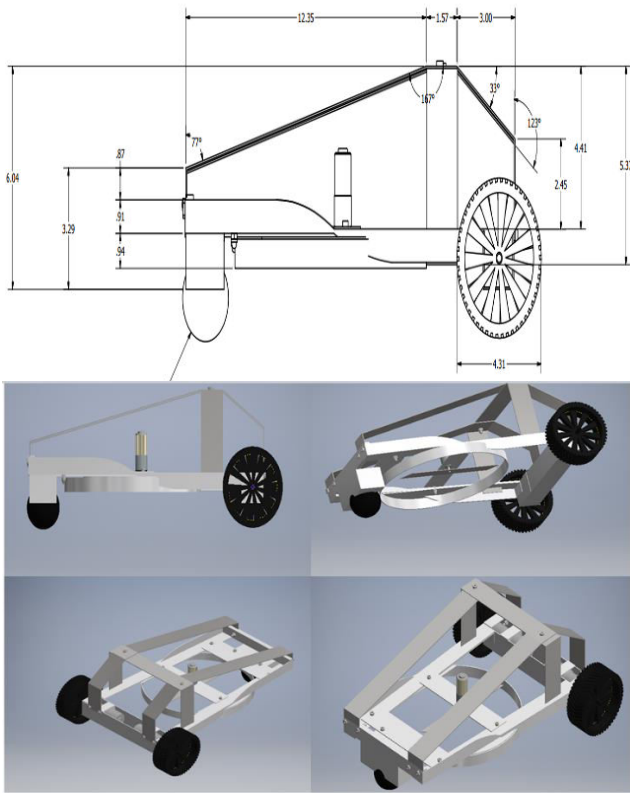

Figure-5. Design and simulation of sketched car robot using Autodesk Inventor.

A caster wheel was used due to its light weight in order to avoid overload of the robot. The body work of the robot was designed to accommodate all the essential components of the system. The IR sensor module is placed at the bottom of the frame work to face the ground and monitor just above the grass level for any obstacle on the path of the robot. Also the ultrasonic sensor is placed just on top of the robot high enough to follow the pavement of the lawn to avoid hitting the lawn. Similarly, a simple experiment was conducted through the Arduino IDE to calculate the time duration to detect the actual distance of object by the ultrasonic sensor and the result is presented in Table-2 obtained through the serial monitor. A simple setup ultrasonic sensor experiment for obstacle detection is depicted in Figure-6.

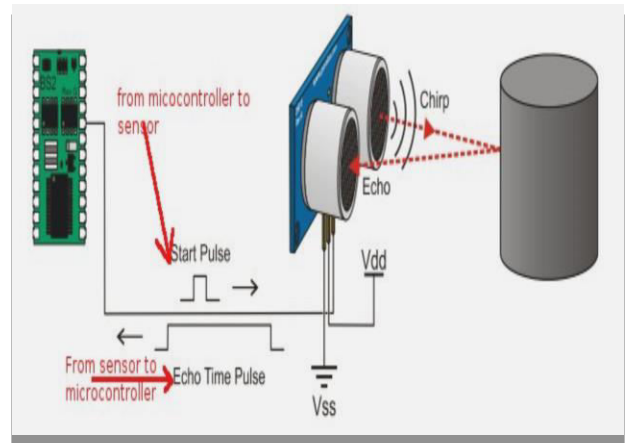

Figure-6. How the ping sensor works [13].

RESULT AND DISCUSSIONS

The developed system was tested by placing obstacle at various distances across its path. The responses of sensors were evaluated individually, since they were positioned on different parts of the autonomous car. Table-1 summarizes the results obtained.

The accuracy and probability of failure are given as:

$$T_o = A_{s1} + A_{s2} \tag{2}$$

$$A_{s1} = A_{s2} = \frac{O_a}{T_o} \tag{3}$$

where

- A_{s1} = Accuracy of IR sensor
- A_{s2} = Accuracy of the ultrasonic sensor
- O_a = Total number of obstacle avoided
- T_o = Total number of obstacle Tested

The probability of Failure (P_f) is given as

$$P_f = \frac{\text{Total number of Failed Detection and avoided}}{\text{Total number of obstacle tested}} \tag{4}$$

The percentage (%) accuracy and probability of failure is calculated as follows:

$$\% \text{ Accuracy} = \frac{17}{20} * 100 = 85\%$$

$$P_f = \frac{3}{20} = 0.15$$

Therefore, an accuracy and probability of failure of 85% and 0.15 were obtained respectively.

The comparison between results of calculated time duration and the experimental time duration for the ultrasonic sensor to detect the actual object distances is presented in Table-2. By assuming range of values for the obstacle distance, Equation (1) above is applied to calculate t_{IN} (duration).

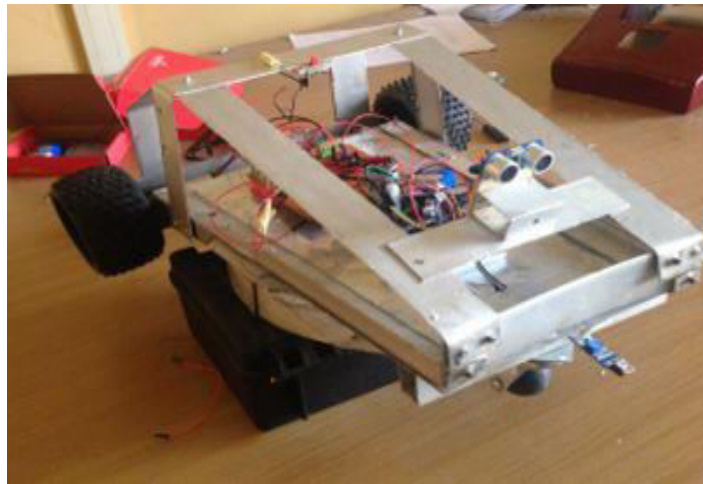

Figure-7. The robot completed frame work.

Table-1. Analysis of Ultrasonic sensor for different actual object distances.

S. no.	Calculated t_{IN} (Duration)(ms)	Experimental t_{IN} (Duration) (ms) by ultrasonic sensor	Actual distance of object (cm)
1	680	580	10
2	1360	1160	20
3	2040	1754	30
4	2720	2322	40
5	3400	2956	50
6	4080	3510	60
7	4760	4031	70
8	5440	4656	80
9	6120	5262	90
10	6800	5859	100
11	19040	16514	280
12	20400	20000	300

The characteristic profile generated by the ultrasonic sensor is linear and stable which can be observed in Figure-8. This is as result of the smooth and good refraction surface of obstacle used in the experiment. Also, there is variation in the comparative profiles for both calculated and experimental time durations obtained in Figure-8. It is established that as the distance of the obstacle gradually increases, time taken for the ultrasonic sensor to detect the object also increases gradually.

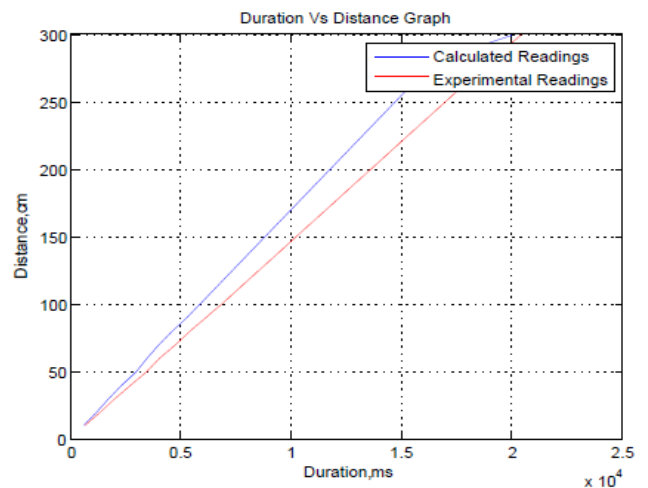

Figure-8. Response of the Ultrasonic sensor with respect to the obstacle detection at various distances.



CONCLUSIONS

This paper presented a simple, cost effective obstacle detection and avoidance system for an unmanned land mover. Two pairs of heterogonous sensors were employed to detect obstacles along the path of the mobile robot. A degree of accuracy and minimum probability of failure were obtained. The evaluation on the autonomous system shows that it is capable of avoiding obstacles, ability to avoid collision and change its position. It is evident that, with this design more functionality can be added to this design to perform various functions with little or no intervention of humans. Finally, the robot was made to be remote controlled using an IR receiver and a remote controller. This project will be helpful in hostile environment, defense and security sectors of the country.

REFERENCES

- [1] J. Seja and M. Banshidhar. 2013. Obstacle detection and avoidance by a mobile robot. National Institute of Technology, Rourkela. B.Sc. thesis. pp. 1-9.
- [2] E. Daniel Wang. Obstacle Avoidance Algorithms and Sensors for Autonomous Robots. www2.ece.gatech.edu/academic/courses/ece4007/10fall/ECE4007L03/.../ewang9.doc.
- [3] L. Navarro-Serment, C. Paredis and P. Khosla. 1999. A beacon system for the localization of distributed robotic teams. Proceedings of the International Conference on Field and Service Robotics. pp. 232-237.
- [4] T. Bailey, E. Nebot, J. Rosenblatt and H Durrant-Whyte. 1999. Robust distinctive place recognition for topological maps. Proceedings of the International Conference on Field and Service Robotics. pp. 347-352.
- [5] N. Harper and P. McKerrow. 1999. Detecting plants for landmarks with ultrasonic sensing. Proceedings of the International Conference on Field and Service Robotics, pp. 144-149, 1999.
- [6] R. Chatila, G. Andrade, S. Lacroix and A. Mallet. 1999. Motion control for a planetary rover. Proceedings of the International Conference on Field and Service Robotics. pp. 381-388.
- [7] A. Soto, M. Saptharishi, A. Ollenu, J. Dolan and P. Khosla. 1999. Cyber-ATVS: dynamic and distributed reconnaissance and surveillance using all terrain UGVs. Proceedings of the International Conference on Field and Service Robotics. pp. 329-334.
- [8] D. Langer, M. Mettenleiter, F. Hartl and C. Frohlich. 1999. Imaging laser radar for 3-D surveying and cad modelling of real world environments. Proceedings of the International Conference on Field and Service Robotics. pp. 13-18.
- [9] A. Foessel, S. Chheda and D. Apostolopoulos. 1999. Short-range millimeter-wave radar perception in a polar environment. Proceedings of the International Conference on Field and Service Robotics. pp. 133-138.
- [10] T. Oomichi, N. Kawauchi and Y. Fuke. 1999. Hierarchy control system for vehicle navigation based on information of sensor fusion perception depending on 85 measuring distance layer. Proceedings of the International Conference on Field and Service Robotics. pp. 197-201.
- [11] E. Prassler, J. Scholz and P. Fiorini. 1999. Maid: A robotic wheelchair roaming in a railway station. Proceedings of the International Conference on Field and Service Robotics. pp. 31-36.
- [12] S. Thrun, M. Bennewitz, W. Burgard, A. Cremers, F. Dellaert, D. Fox, D. Hahnel, G. Lakemeyer, C. Rosenberg, N. Roy, J. Schulte and W. Steiner. 1999. Experiences with two deployed interactive tour-guide robots. Proceedings of the International Conference on Field and Service Robotics. pp. 37-42.
- [13] R. Meier, T. Fong, C. Thorpe and C. Baur. 1999. A sensor fusion based user interface for vehicle teleoperation. Proceedings of the International Conference on Field and Service Robotics. pp. 244-249.
- [14] M. Torrie, S. Veeramachaneni, B. Abbott. 1998. Laser-based obstacle detection and avoidance system. Proceedings of the SPIE Conference on Robotics and Semi-Robotic Ground Vehicle Technology. pp. 2-7.
- [15] I. Ulrich and J. Borenstein. 1998. VFH+: Reliable obstacle avoidance for fast mobile robots. Proceedings of the 1998 IEEE Conference on Robotics and Automation. pp. 1572-1577.
- [16] J. Borenstein and Y. Koren. 1991. The vector field histogram - fast obstacle avoidance for mobile robots. IEEE Journal of Robotics and Automation. 7(3): 278-288.
- [17] J. Borenstein and Y. Koren. 1999. Histogramic in-motion mapping for mobile robot obstacle avoidance.



IEEE Journal of Robotics and Automation. 7(4): 535-539.

- [18] J. Borenstein and Y. Koren. 1990. Real-time obstacle avoidance for fast mobile robots in cluttered environments. Proceedings of the IEEE Conference on Robotics and Automation. pp. 572-577.
- [19] B. Holt and J. Borenstein. 1996. Omni Nav: Obstacle avoidance for large, non-circular, omni directional mobile robots. Robotics and Manufacturing. 6: 311-317.
- [20] H. C. Moon and H.C. Lee and J. H. Kim. 2006. Obstacle Detecting System of Unmanned Ground Vehicle. SICE-ICASE, 2006. International Joint Conference.
- [21] C. Qingyang and S. Zhenping and L. Daxue and F. Yugiang and L. Xiaohui. 2012. Local Path Planning for an Unmanned Ground Vehicle Based on SVM. International Journal of Advanced Robotic Systems. 9: 246.
- [22] P. Fofilos and K. I. Xanthopoulos and E.A. Romanos and K. Zikidis and N. Kanellopoulos. 2014. An Unmanned Ground Vehicle for Remote-Controlled Surveillance. Journal of Computations & Modelling. 4(1): 223-236.
- [23] P.N. Nguyen and H. J. Titus. 2009. Reliability and Failure in Unmanned Ground Vehicle (UGV). Ground Robotic Research Center Technical Report University of Michigan.
- [24] I. Karabegovic and E. Karabegovic and E. Husak. 2012. Trend of Industrial Robot Share in Different Branches of Industry in America. International Journal of Engineering Research and Applications (IJERA). 2(2): 479-485.
- [25] J. Izquierdo and P. Feldman. 2014. Trends in Robotics - Market Assessment. The Association for Packaging and Processing Technologies 11911 Freedom Drive, Suite 600 Reston, Virginia 20190, February.
- [26] K. Bhagat and S. Deshmukh and S. Dhonde and S. Ghag. 2016. Obstacle Avoidance Robot. International Journal of Science, Engineering and Technology Research (IJSETR). 5(2).