

See discussions, stats, and author profiles for this publication at: <https://www.researchgate.net/publication/303824805>

# COMPUTER AIDED DRAFTING AND CONSTRUCTION OF STANDARD DRAFTING TABLE FOR COLLEGE OF ENGINEERING STUDIO IN AFE BABALOLA UNIVERSITY

Research · June 2016

DOI: 10.13140/RG.2.1.3329.2404

0

READS

699

1 author:



**Bankole I. Oladapo**

De Montfort University

20 PUBLICATIONS 37 CITATIONS

[SEE PROFILE](#)

Some of the authors of this publication are also working on these related projects:



RELIABILITY STUDY OF POWER TRANSMISSION AT AFE BABALOLA UNIVERSITY,ADO EKITI [View project](#)



Mechatronics [View project](#)

# COMPUTER AIDED DRAFTING AND CONSTRUCTION OF STANDARD DRAFTING TABLE FOR COLLEGE OF ENGINEERING STUDIO IN AFE BABALOLA UNIVERSITY

**Bankole I. Oladapo<sup>\*</sup>, Aban Stephen, Azeez M. Temitayo, Afolabi S. Oluwole**

*Dept. of Mechanical & Mechatronics Eng. Afe Babalola University, Ado-Ekiti, Nigeria*

*<sup>\*</sup>Corresponding author's e-mail: bankolyable@yahoo.com*

**Abstract:** There is a serious need to design and construct a more convenient drafting table with a reduce cost for the high number of Students using design studio in mechanical and mechatronics department, Afe Babalola University Ado Ekiti, Nigeria. This project presents the design and fabrication of a standard drafting table with the use of "AutoCAD TM" software. The design helps to find out a precise dimensions of various part of table with great accuracy within small time and gives fine representation of drafting table. The detail drawing enhance the speed of production as each technician working on the table work on different part which makes the fabrication more faster and précised. The joining of the part was done through arc-welding using gauge 10 electrode. The slot on the adjusting hanger was machine on milling machine. The table was fabricated using a 2"\*2" square pipe of 2mm thick of mild steal material commonly available in market. Main part are: stand of 2"\*2" 3ft long, middle and stand brace 2"\*2" 2.5ft long, the base of 1ft and the top was made of a plywood of 3ft by 4ft as the standard size for A1 paper for drafting. The straight edge of the board help in the squaring of the drafting table and a accurate drafting. The total cost of production per one is approximately N22,300. Compare to the market price from some other company of the same product of \$250 as at the time of production. This makes the institution to produce 50pieces of the drafting table.

**Keyword:** AutoCAD, Drafting table, design and construct.

## 1. INTRODUCTION

Computer technology have been a great benefit for both designing and manufacturing Industries to manage their processes and focus their efforts on increasing the overall efficiency and productivity. [1-2]. This have made the Industry to gain more time which was usually lost on pen drafting, designing and it long process way of correction. The introduction of Computer Aided Design (CAD) has drastically increase productivity across the globe in the industry. [3]. This has made many manufacturing company to meet there customer's requirements on time. The production and manufacturing of the drafting table the part is fabricated from a 3D solid model produced in Computer Aided Design (CAD). The process and product is considered to be material efficient because material is added in layers which reduce the number of material wasted in part

production, compared to the material removed during the processes [4]. More characteristics and benefits of CAD and additive manufacturing method are well preserved and documented [5-6]. CAD is an automated system for drafting, design, and display of graphically oriented information. It is also used in the manufacturing process for layouts. [7]. Industrial manufacturing activity can broadly be group into (i.e. mechanical industries making discrete components) mass production and batch production etc. the term connected to **CAD** is **CAM** (Computer Aided Manufacturing). For designers, CAD has become indispensable. [8-9]. There are different type of cad, in this project AutoCAD was used. The drafting table was fabricated with mild steel using carbon electrode of gauge 10. This mild steel material properties, of high elastic models, higher service temperature,

good wear resistance, light part weight, high electrical and god thermal conductivity. [11] The excellent mechanical properties of mild steel and is relatively low production cost and machinability, make it very good for fabrication of different machine. [12] the simplicity of design the total costs of production compare to the cost of buying in the market made the institution to support the production.

### ***1.1 Statement of the problem***

The use of classroom reading table and chair makes it difficult for good drafting for student in engineering college during their engineering drawing, assignment, examination and their final year project. The size of the class room table is small that it can not contain drafting paper conveniently. This is common in many institution in Nigeria due to bad management. In many institution in Nigeria its common for student to go about with drawing board to the class room for class work, assignment and examination. This type of portable drawing board normally don't last long due to the material used and how it was being handle by student. The cost of purchasing a drafting table of such quality and size and transportation is high compare to producing it within the institution. This bring about the necessity of designing a low cost drafting table that will be affordable and efficiently comfortable.

### ***1.2. Objectives of the work***

The specific objectives of the work were to design, construct, a low-cost drafting table, for the use of the college and stress-free drafting in the design studio.

## **2. DESIGN AND MANUFACTURING PROCESSES**

### **2.1 Design and Construction of The Stand**

The solid model of the stand and the base support of the table with a length of 915mm, equivalent to 3ft commonly use by technicians, of width 458mm, and 50mm as the regular thickness 2''/2'' square pipe as commonly called, which is shown in the Fig. 1 below. Fig. 2 shows braise for the stand with length of 815mm, breath of 50mm square pipe, and of 2mm thickness. Screw nod and nut for angle height adjustment of 60mm length, 10 mm diameter shown in Fig. 3. All this component are made from mild steel.

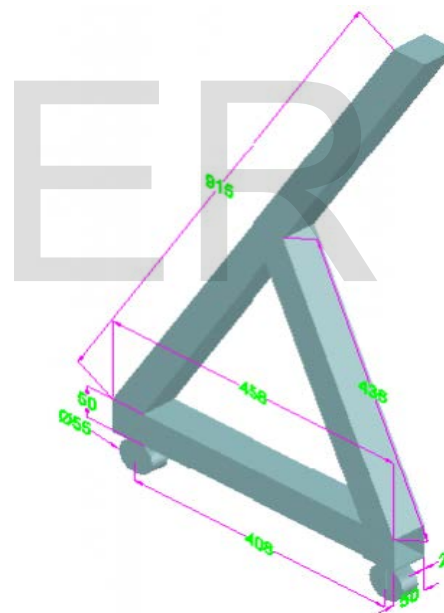

Fig. 1: Table stand and base support with dimension

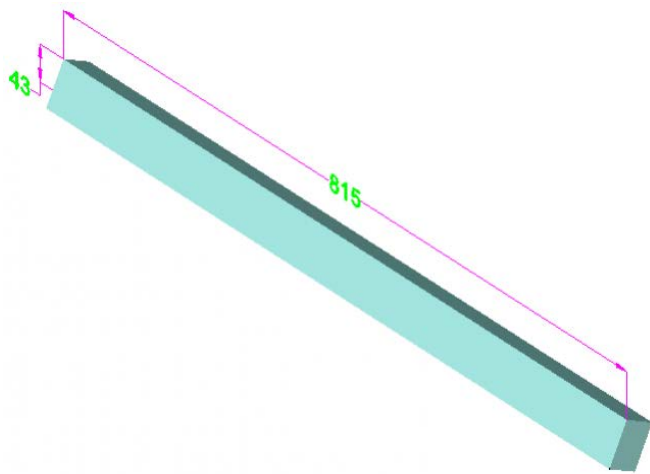

Fig. 2: Braise for the stand

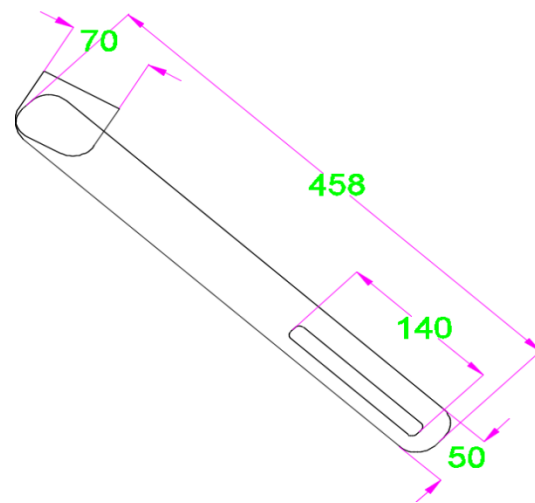

Fig.4: The height and slat adjusters



Fig.3: The Screw nod for Angle and Height adjustment

## 2.2 Design and Construction of The Board Carriage.

The board carriage was design and fabricated from mild steel from part to part. The height and slat adjusters were made from flat bar of 458mm long of 50mm width of 5mm thickness. A slot of about 140mm was mill on the height adjuster for moving and slating of the table, with milling machine as shown Fig. 4 below. Two braise for the carriage of the drawing board made from angle bar of 25mm by 25mm of 1220mm long of 4mm thick, which make the drafting table strong and firm as shown in Fig. 5 below. The complete assembly of the carriage can be seen in Fig. 6

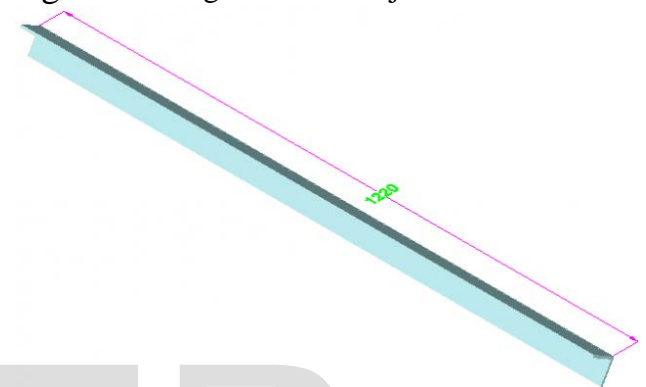

Fig. 5: Braise for the carriage of the drawing board

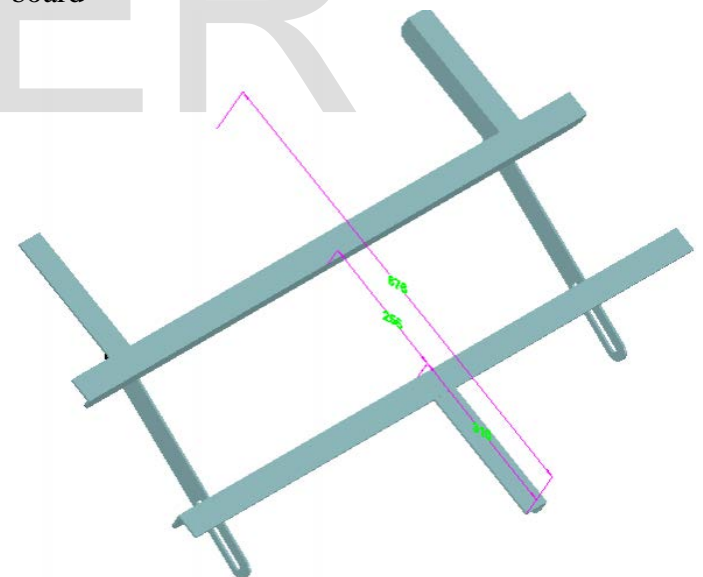

Fig. 6: The complete assembly of the carriage

A mobile tire for the table to be moveable was design. The tire is made rubber materials of 55mm diameter of 25mm thickness. It has a stopper to control the movement of the table. A flat bar of 40mm long of 10mm width of 3mm thick was used to support the tire for alignment and strength

as Shown in Fig.7. Fig. 8 shown the drawing board made from a strong plywood, cut and machine to 1200mm long 900width of 35mm thickness as the standard requirement by NUC (Nigeria University Council) which is the size of A0 paper for drafting. Also Fig. 9 show the assembly of the part without the board.

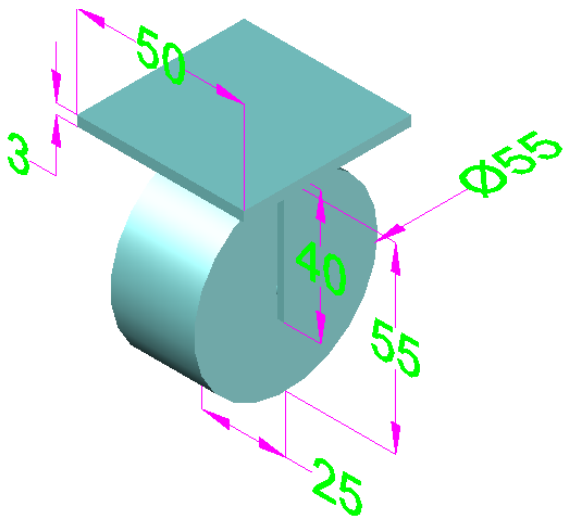

Fig. 7: The tire is made rubber materials

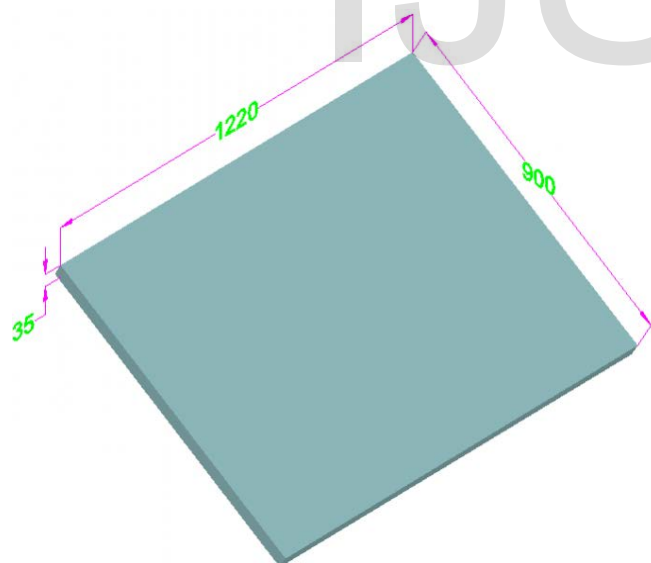

Fig. 8: The drawing board



Fig.9: Assembly of the part without the board

### 3. Result and Discussion

The following material and equipments were used for fabrication and construction of the table: Arc-argon welding machine, gauge 10 electrodes for joining the part together, grinding disc, grinding machine, Lathe, facing tools, turning tools and other hand tools. The fabrication tools include, marking out, machining, cutting, joining, drilling and fitting. Some other woodwork machine were also use to cut, shape and give good finishing to the plywood used for the drafting table. The plywood was bolted down using screw nail and glue to hold the angle bar and the plywood together.

#### 3.1. Bill of material of complete Drafting table

Table 1: Bill of material complete components involved for design and construction of the drafting table

Serial No	Name of the component	Part Description	Material	Quantity	Cost Per Part (Naira)	Foreign	Konga (Naira)
1.	Table stand	3ft*2 ft*2in square pipe	Mild steel	2	3,000		
2.	Base Support	2ft*2in*2in square pipe	Mild steel	2	600		
3.	Braise Stand	2ft*2in*2in square pipe	Mild steel	2	600		
4.	Screw Nod	1in*1in*3/8in	Mild steel	4	600		



5.	Braise for Carriage	3.8ft*2in*2in angle bar	Mild steel	2	2,000		
6.	Braise	3ft*2in*2in square pipe	Mild steel	3	3,000		
6.	Height Adjusters	2ft*2in*3/8in flat bar	Mild steel	2	2,000		
7.	Tires	Robber cast wheel	Rubber	4	2,000		
8.	Drawing Board	4ft*3ft*1/2in	Wood	1	4,000		
9.	Miscellaneous				4,500		
10.	<b>Total</b>				22,300	\$250	65,000



Fig. 10: Fabrication Processes of the drafting Table at the College of Engineering Central workshop, Afe Babalola University, Ado-Ekiti, Nigeria

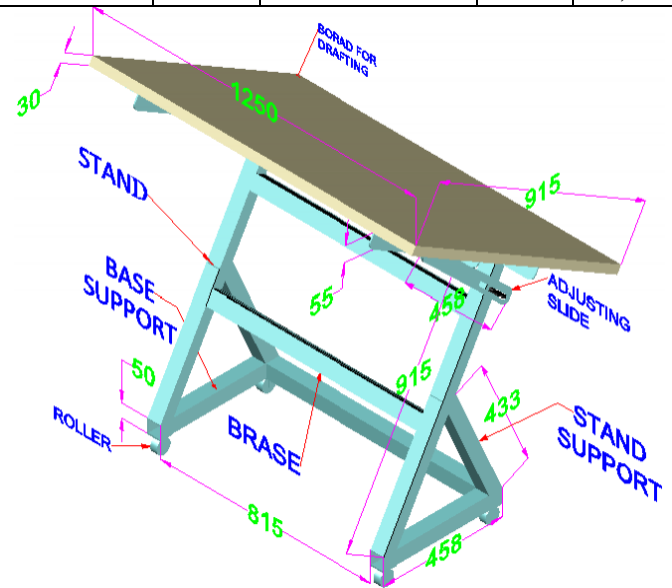

Fig. 11: Assembled view of the Drafting Table.



Fig. 12: Photography of Drafting Table Produce at the Design Studio of Mechanical/Mechatronics Department

#### 4. Conclusions

Independence is one of the major drives of development and animated economy. From the above result, it is clear that the drafting table was designed and fabricated successfully. This drafting table has been designed and fabricated with the use of locally accessible resources. The

drafting table is a portable, flexible, movable, less bulky and easy to Adjust to suit any drafting position. Information gathered from student show that the table is flexible enough to give reasonable comfort of about 89% efficiency to work on compare to the classroom table and mobile drawing board. The drafting Table do not need any motorize mechanism but simple to operate for the user. The actual capacity is to contain A0 drafting paper for better presentation and movement of pen within the drawing area without much disturbance. The net present value of the drafting table was N22,000 to N25,000 which was attractive to the institution. This was favorable to the institution compare to different market price of \$250 for foreign and about N65,000 for locally source drafting table. This encourage the institution to ask the workshop to produce other 50pieces drafting table of a smaller size of a reduced scale of 2.

## REFERENCE

- [1] Vikram Sharma, 2009, Fundamental of CAD/CAM, ISBN: 9788189757946, Publisher- S.K.Kataria & sons.
- [2] P.K.Bharti, Osama Lari, 2010, Computer Aided Manufacturing, ISBN:978-93-80257-09-9, Publisher- Word-press.
- [3] Kuldeep Kumar Sareen, Chandan Deep Singh Grewal, 2007, CAD/CAM Theory and concepts, ISBN: 81-219-2874-5, Publisher- S.Chand & Company Ltd
- [4] Levy G.N., Schindel, R., Kruth, J.-P. Rapid manufacturing and rapid tooling with layer manufacturing (LM) technologies, state of the art and future perspectives. Cirp Annals Manufacturing Technology 2003; 52: 589-609.
- [5] Holmström J., Partanen, J., Tuomi, J., Walter, M. Rapid manufacturing in the spare parts supply chain: alternative approaches to capacity deployment. Journal of Manufacturing Technology Management 2010; 21: 687-697.
- [6] Kruth J.P., Leu, M.C., Nakagawa, T. Progress in Additive Manufacturing and Rapid Prototyping. CIRP Annals – Manufacturing Technology 1998; 47 525-540.
- [7] T.K.Kundra, 1993, Computer Aided Manufacturing, ISBN: 9780074631034, Publisher- Tata McGraw-Hill Education.
- [8] Mikell P Groover, 1984, CAD/CAM- Computer Aided Design & Manufacturing, ISBN: 9788177584165, Publisher- Pearson Education India.
- [9] P.N.Rao, 2004, CAD/CAM: Principles and Applications, ISBN: 9780070583733, Publisher- Tata McGraw-Hill Education.
- [10] S.A. Sajjadi, H.R. Ezatpour, H. Beygi, “Microstructure and mechanical properties of Al Al<sub>2</sub>O<sub>3</sub> micro and nano composites fabricated by stir casting”. In:proceedings of 14th national conference on Journal of materials science and engineering ,Tehran,Iran, 2010, 325-32.
- [11] Alan Peel Ceng, James Herbert”. “Technology for Electromagnetic Stirring of Aluminum Reverberatory Furnaces”. The minerals Metals and Materials society, 2011.

# IJSER