

Nova Gorica Polytechnic
School of Environmental Sciences

Monika Peterlin

Perception of environmental data by different social groups in the EIA process

Case study:

**Environmental data perception and beliefs of Port of Koper employees
and the general population in the Koper area**

Doctoral Thesis

Nova Gorica, October 2005

ACKNOWLEDGMENTS

I would like to thank my advisers Prof. B. C. Kross and Prof. B. Kontič for their guidance and help with this work.

My thanks go also to Prof. M. Kotar of the Biotechnical Faculty – Department of Forestry and Renewable Forest Resources in Ljubljana for his advice on statistical methods and to Dr. C. Ferguson from the University of Iowa College of Medicine – Office of Consultation and Research in Medical Education, Iowa City, for her advice on the content and structure of questionnaires.

I am also grateful to all those respondents who had the patience to fill out the questionnaires and especially to those who participated in both surveys. I would also like to thank the management and employees of the Port of Koper for their cooperation with the surveys and for giving their permission to use the Port as a case study.

This dissertation was supported by the Institute for Water of the Republic of Slovenia - Marine department, and I would like to thank all my co-workers and especially to L. Battelino and V. Kobav for their patience.

I would like to thank B. van de Wetering and D. Heath for their valuable help and moral support.

Finally, I would like to give my special thanks and love to my family and friends, for all their support on this intellectual adventure.

'It is only through the deep concern, information and knowledge, commitment and action of the people of the world that environmental problems can be answered. Laws and institutions are not enough. The will of the people must be powerful enough, insistent enough, to bring about the truly good life for all mankind.'

- *Commission to Study the Organization of Peace 1972* -

ABSTRACT

The subject of investigation in this doctoral dissertation is the influence of: (i) environmental information provided in an Environmental Impact Assessment (EIA) process on the opinion about environmental issues in a local community and of (ii) institutional constraints on perception of environmental data. The influence of institutional constraints (i.e. employment) is investigated by comparing the opinions of employees of an industrial activity to those of the local population. The influence of the information provided in the EIA process on opinions is analysed by surveys performed before and after the provision of relevant environmental information.

In order to take into account some of the complexity of interaction between human activities and environmental issues the research addressed also (i) the perception of environmental issues in coastal area, (ii) the predominant social paradigm in the society, attitudes toward the environment and responsibility to nature and environmental issues, (iii) the degree of trust in information sources and opinion on the effectiveness of the information modes used in the process. In addition, general social and political changes in the region, as well as in the whole country (for example accession to the EU, competitive free market, new understanding of economy and job provisions, changes in political attitudes from traditional socialist - left wing, towards more business and conservatism - right wing), have been taken into account when interpreting observed changes in perception.

An industrial port - Port of Koper in Slovenia was chosen as a case study. Participants in the study are respondents, randomly selected from two comparison groups – general population and employees of the Port. Research consists of three parts - (i) an initial survey in 2001, (ii) release of the environmental information about environmental impacts of the Port in a presentation as part of the EIA process and (iii) a second survey in 2003.

Results show that perception of environmental issues in a coastal area is similar for both groups – general population and employees, except for the opinion on Ports' environmental impacts. Differences in perception between the general population and employees about the environmental impact of the Port confirmed the expected influence of institutional constraint. Changes over time in opinions were analysed to identify the influence of the information provided in the EIA process. The study identifies two types of changes in the general population group. First, it is obvious, that the general population graded Ports' impacts significantly lower after the EIA process, while employees graded the Ports overall impacts higher in the second survey, which we assign to changes in understanding of issues due to the information provided in the EIA process prior to the 2003 survey. Second – and surprisingly, when comparing impacts of the Port to other pollution sources, the general population graded the Port's impacts higher after the information provision. We assign this change to the popularisation of the Port, which was more exposed in the media and discussed in the society and which is definitely a perception thing.

An analyses of the opinions about moral responsibility towards the environment, priority values, trust in technological development and readiness to participate in environmental protection shows that there are few differences among the assigned groups. In conclusion, the public and employees share values and views about general environmental issues.

The differences occur in the opinions relating to the Port and its environmental impact. Obviously, economic dependence plays a role!

We could see that differences in opinions about Port's impacts between the two main groups – employees and general population became smaller in the time between 2001-2003. This is obviously due to information provided in the EIA process and otherwise. However, this change cannot be assigned solely to information provision, but partly also to certain general changes in the society. For example 'readiness to participate in environmental protection' (Graph 6.22 – Readiness to participate in environmental protection) results show trends of decrease in this readiness, which we may assign to the above-mentioned changes in the society.

KEYWORDS

Environmental impact assessment, public opinion, environmental perception, environmental impacts, sustainable development, coastal zone, industrial port, survey research, environmental information, institutional constraints.

POVZETEK

Obravnavali smo (i) vpliv okoljske informacije, podane v okviru procesa Presoje vplivov na okolje, na javno mnenje ter (ii) vpliv institucionalne pripadnosti na percepcijo okoljskih vplivov. Vpliv institucionalne pripadnosti (zaposlitve) na dojetje in tolmačenje okoljskih vplivov (percepcija) smo analizirali s primerjavo mnenja lokalne skupnosti z mnenjem zaposlenih v podjetju o stanju okolja in vplivih na okolje za dejavnost, ki jo izvaja njihovo podjetje. Vpliv okoljske informacije, podane v okviru Presoje vplivov na okolje pa smo obravnavali s primerjavo javnega mnenja pred in po opravljenih razgrnitvah poročil o vplivih na okolje in javnih predstavitev.

Da bi vsaj deloma upoštevali kompleksnost interakcije med antropogenimi dejavnostmi in njihovimi vplivi na okolje smo obravnavali tudi (i) percepcijo okoljskih vplivov v obalnem območju, (ii) prevladujoči odnos družbe do okolja ter čut moralne odgovornosti do narave in okoljskih vprašanj, (iii) zaupanje v vire informacij ter mnenje o učinkovitosti podajanja informacij na različne načine in v različnih medijih. Pri interpretaciji rezultatov smo upoštevali, da so na spremembe v percepciji okoljskih podatkov poleg posredovane informacije vplivale tudi splošne politične in socialne spremembe v družbi (kot so pristop Slovenije v EU, svobodna konkurenca in novi trendi pri ekonomskem razvoju, spremembe položaja delavcev ter spremembe v politiki iz tradicionalne socialistične – levo usmerjene družbe v bolj konzervativno – desno usmerjeno družbo).

Luka Koper v Sloveniji in lokalna skupnost v njeni okolici so bili izbrani za študijo primera. V raziskavi javnega mnenja sta sodelovali dve skupini - naključno izbrani prebivalci v lokalni skupnosti ter naključno izbrani zaposleni iz Luke Koper. Raziskava sestoji iz treh delov: (i) začetna raziskava javnega mnenja v letu 2001, (ii) posredovanje informacije - predstavitev okoljskih podatkov v okviru Presoje vplivov na okolje za ureditev novih skladiščnih površin v Luki Koper ter (iii) druga raziskava javnega mnenja v letu 2003.

Primerjava percepcije okoljskih vidikov v obalnem območju med obema skupinama - laično javnostjo in zaposlenimi kaže, da se njihovo mnenje ne razlikuje. Mnenja obeh skupin se razlikujejo le v percepciji okoljskih vidikov Luke Koper, kar potrjuje pričakovan vpliv institucionalne vezanosti na tolmačenje okoljskih vplivov podjetja. Analizirali smo tudi spremembe javnega mnenja med obema anketama z namenom ugotoviti možen vpliv okoljske informacije na javno mnenje. Identificirali smo dve vrsti sprememb. Prvič - v primeru ločenega ocenjevanja posameznih vplivov Luke je lokalno prebivalstvo po predstavitev v okviru procesa Presoje vplivov ocenilo skupne vplive Luke na okolje z nižjo povprečno oceno, medtem ko so jih zaposleni ocenili z višjo skupno povprečno oceno kot v prvi raziskavi. Drugič smo dobili presenetljive rezultate, saj je v relaciji glede na ostale potencialne vire onesnaženja okolja lokalno prebivalstvo ocenilo vplive Luke z višjo povprečno oceno po končanih predstavitev. To pripisujemo spremembi dojetja zaradi popularizacije vprašanja zaradi razprav v lokalni skupnosti v času predstavitev, saj je bila Luka bolj izpostavljena kot ostale dejavnosti.

Analiza odgovorov na splošna vprašanja kaže, da imata obe skupini - laična javnost in zaposleni, podobne splošne etične in praktične poglede na varstvo okolja, podobne vrednote, zaupanje v tehnološki razvoj in podobno pripravljenost za sodelovanje pri varovanju okolja.

Mnenje obeh skupin se pomembno razlikuje le v mnenju glede vprašanj o Luki Koper, kar kaže na vpliv institucionalne pripadnosti na percepcijo okoljskih vplivov.

Razlike v mnenju o vplivih Luke Koper med laično javnostjo in zaposlenimi so se v času med obema anketama, ki sta potekali leta 2001 in 2003, zmanjšali. To pripisujemo vplivom informacije v okviru procesa Presoje vplivov na okolje in drugim povezanim aktivnostim. Teh sprememb pa ne moremo pripisati izključno vplivu informacije, temveč so lahko posledica vplivov ekonomskih in socioloških sprememb v družbi med obema anketama. Za primer – vidimo, da 'pripravljenost za sodelovanje pri varovanju okolja' (Graf 22) kaže trend upadanja, kar bi lahko pripisali zgoraj navedenim spremembam v družbi.

KLJUČNE BESEDE

Presoja vplivov na okolje, poročilo o vplivih na okolje, javno mnenje, percepcija okoljskih podatkov, trajnostni razvoj, obalno območje, pristanišče, raziskava javnega mnenja, informacije o vplivih na okolje, institucionalna pripadnost.

CONTENS

LIST OF FIGURES	xiii
LIST OF TABLES	xiii
LIST OF GRAPHS	xiv
1. INTRODUCTION.....	1
1.1 Framework of reference – problem statement	1
1.2 Statement of objectives	1
1.3 Significance of the work	2
2. LITERATURE REVIEW.....	3
2.1 Relevant research	3
2.2 Relevant research in Slovenia.....	4
3. THEORETICAL STRUCTURE OF THE RESEARCH	6
3.1 Theoretical basis	6
3.2 Research questions.....	8
3.3 Hypotheses definition	9
3.4 Research outline.....	9
4. METHODOLOGY	11
4.1 Design of the research	11
4.2 Variables definition	13
4.3 Variables association.....	14
4.4 Hypothesis testing and significance	15
4.5 Instrument of measurement - questionnaire	17
4.5.1 Levels of measurement.....	17
4.5.2 Questionnaire	17
4.6 Response data evaluation.....	18
4.6.1 Data quantification.....	18
4.6.2 Data qualification	19
4.7 Validity of the research	19
4.7.1 Standardization.....	19
4.7.2 Internal validity and reliability	19
4.7.3 Construct validity	20
4.8 Uncertainties.....	20
5. CASE STUDY	22
5.1 Environmental setting of the research.....	22
5.2 Ranking of environmental impacts	25
5.3 Population sample	25
5.4 Pilot study	27
5.5 First survey	27
5.6 Presentation of EIA report data for Port of Koper	27
5.7 The second survey	32

6. RESULTS	33
6.1 Respondents sample parameters	33
6.2 Comparison of respondents groups	33
6.3 Quantitative results.....	33
6.4 Hypothesis testing and results qualification	35
6.4 Results aggregation.....	60
7. DISCUSSION	62
7.1 General.....	62
7.2 Results in the light of uncertainty	64
8. RECOMMENDATIONS	66
8.1 Recommendations for public involvement	66
8.2 Future work.....	67
9. CONCLUSION	68
10. REFERENCES.....	69
11. APPENDIX.....	73

LIST OF FIGURES

Fig. 3.1:	Stern et. al.'s Causal Model of Environmental Concern.....	6
Fig. 3.2:	Outline of the research	10
Fig. 4.1:	General course of research	11
Fig. 4.2:	Data aggregation	13
Fig. 4.3:	Survey design.....	14
Fig. 5.1:	Sampling locations.....	26
Fig. 5.2:	Disposition of assessed projects	28
Fig. 5.3:	Disposition of the curtain and its' construction (2004).....	29

LIST OF TABLES

Table 4.1	Association between questions and variables.....	15
Table 5.1	Ranking of environmental impacts	25
Table 5.2	Population in sampling settlements	26
Table 6.1	Respondents sample size for each location.....	33
Table 6.2	Quantification of results – trust in sources of information.....	34
Table 6.3	Significant differences in trust into information sources, opinion about sources reliability and modes of information effectiveness.....	41
Table 6.4	Significant differences – value structure on which society currently depends	44
Table 6.5	Quantitative data – opinion about the Port's environmental impact	53
Table 6.6	Results of 2001 and 2003 survey - Means – Agreement with statements	54
Table 6.7	Variables influencing trust in science and technology and in technological solutions of environmental problems	56
Table 6.8	Variables that influence results.....	61

LIST OF GRAPHS

Graph 6.1:	Graphic presentation of quantitative results – opinion about trust in information sources	34
Graph 6.2:	Trust to information sources – opinion of employees, general population and experts (mean ranks).....	36
Graph 6.3:	Mean results for 'effectiveness of information modes, organized by PK.....	37
Graph 6.4:	Effectiveness of 'Open door days in the Port' and 'Public presentations in EIA process'.....	38
Graph 6.5:	Mean results for “reliability of information source about issues, connected to the Ports’ activities”.....	38
Graph 6.6:	Difference between employees and general population / impact of gender – reporters information.....	39
Graph 6.7:	Mean results for: ‘effectiveness of information sources about changes in environment in coastal zone’	40
Graph 6.8:	Mean results for: ‘effectiveness of information about the Ports’ impact’	41
Graph 6.9:	Priorities in Port of Koper development (percentage table).....	42
Graph 6.10:	Value structure in society	43
Graph 6.12:	Air pollution source – comparison survey results to expert data	45
Graph 6.13:	Opinion o air pollution sources	46
Graph 6.14:	Marine pollution sources – Comparison of survey results to expert data.....	47
Graph 6.15:	Opinion about marine pollution sources	47
Graph 6.16:	Opinion about noise pollution sources.....	49
Graph 6.17:	Comparison of both surveys results for general population and employees, compared to expert opinion	49
Graph 6.18:	Opinion about risk to human health.....	51
Graph 6.19:	Opinion about Port of Koper environmental impact in comparison to expert opinion	52
Graph 6.20:	Opinion of employees and general population groups divided by gender (mean ranks).....	53
Graph 6.21:	Opinion about general views and opinions.....	56
Graph 6.22:	Readiness to participate in environmental protection.....	58

1. INTRODUCTION

1.1 Framework of reference – problem statement

In the beginning of the environmental protection movement, main activities were concerned with regulating point sources of emissions by industry, power plants and other technological sources. Their control brought some improvement to environmental status, but mainly because it was effective due to “technological fix” – cleaning of effluents or substitution of substances (like CFC ban). Advanced scientific knowledge very often creates as well as identifies new environmental problems and it is clear that effective environmental protection can only be achieved through common efforts of societies. New environmental policies that include recent knowledge about environmental issues are bringing to contemporary society also new obligations for environmental protection (Kyoto protocol, Water Framework Directive, Marine Strategy, Agricultural policy, Fisheries policy and many others). These policies will never be efficient without broad cooperation from the public. The most unsettling feature of new environmental policies is the fact that they all assume broad public participation – to the level, where society will set up environmental objectives. Therefore an essential element of any environmental policy should be to rise environmental awareness of the population and consequently to change behaviour of societies. To achieve this, the first step is to explore, how concrete society understands (perceives) the environmental issues.

The contemporary environmental decision making process deals with the relationships between citizens, science and technology, where communication of scientifically obtained environmental data occurs whenever there is exchange of information among interested parties about the magnitude of the environmental impact of developments and significance or control of risk, posed by them. Contradictions in decision-making occur, because people perceive environmental issues in different ways and scientific evidence is not considered equally convincing by all. To add to this each person also has his/her own value structure upon which their attitude toward environmental questions is dependant and his/her own interest, regarding a certain activity.

Research on environmental perception is increasingly important because these new environmental policies give strong emphasis to public participation in decision-making process. In these processes environmental information will be provided to people with different levels of education, beliefs and interests – and they will be expected to reach agreement about environmental protection issues.

1.2 Statement of objectives

We believe that the Environmental Impact Assessment (EIA) process is an appropriate vehicle for disseminating environmental information at the local level and has the potential to raise the level of environmental awareness within the society. The aim of this research is to find out, whether information presented to the public during the EIA process influences public opinion and if different social groups perceive environmental problems in different ways.

Investigative interest lies also in checking in the local environment whether or not people, who are economically connected to an activity (employees), share the same concerns about possible harmful environmental impacts caused by the activity as do the general population. This has been investigated elsewhere (Slovic, 1992; Slovic et al., 1998), but never before in Slovenia. We analysed these differences in the context of the moral responsibility towards the environment, general views about priorities in society and the existing perception of environmental issues. From a comparison of the findings for both groups: employees and general population, it should be possible to verify if differences in opinions are really occurring only about the issue of the industrial activity, which is the subject of discussion, or the two groups have intrinsically different values and perceptions.

1.3 Significance of the work

This research contributes to the understanding of differences in people's perception of the environmental issues, which is a key to developing responsive policies and practices and will help to predict, how/if environmental preferences will change if environmental information is provided. It will also contribute to an understanding of how people value the environment and what it means to them. This understanding is key to making effective policy and management decisions.

Environmental perception shapes our knowledge about the environment and involves interpretation of stimuli and assignment of meaning to events or information. The research presented herein is intended to set a method for integrated assessment of the influence of information provided in an EIA process on opinions about environmental impacts of an industrial activity. It also includes an analysis of the influence of individual characteristics of respondents groups (factual data about the population – gender, age, education, employment and residency). The assessment of results will show whether identified differences can really be assigned to information provided in EIA process, or they are related to other reasons, like general changes in the societal characteristics (economy, political inclinations etc.). The latter has not been considered to be statistically tested, but to be accounted for as an additional influencing factor when interpreting results.

On the other hand, what has been controlled in the study and is associated with societal characteristics are gender, education, age, residency and employment as well as values and ethical views, respondents opinions about their priority values, trust in technological development, their feeling of moral responsibility toward environment and their readiness to participate in environmental protection, which may all be related to perception of environmental issues.

The research will also provide recommendations for public involvement in the development process and for a more effective communication of environmental information to the public.

2. LITERATURE REVIEW

2.1 Relevant research

One of the important research fields, dealing with people's attitudes toward the environment, is *environment and behaviour* research, pioneered by Roger G. Barker at the University of Kansas in 1947. During the 1960s in the United States also environmental sociology, environmental psychology (Lewin, 1951), environmental anthropology and environmental studies as a whole had their beginnings. These fields attempt to consider a combination of social and political forces and to address the population as a whole in order to raise the level of environmental awareness (Bechtel, 1997). Some other fields of work that developed in the context of this research, important in explaining the ways people respond to the environment are:

- environmental perception or how we actually perceive the context in which we live with its interplay of social and physical elements,
- environmental appreciation, which is the emotional or evaluative element in terms of how we feel about our environment or the ways in which our evaluation of the environment influences our behaviour,
- environmental personality that is based on the notion of stable traits reflected in our responses to different environments.

Behavioural theories focus on the ways in which the environment prevents or limits behaviour and contributes to environmental psychology in the application of operant principles to modify behaviours and attitudes in the context of environmental issues such as recycling and waste disposal. An ecological perspective sees behaviour as a function of its physical and social setting and extends beyond the focus of the physical environment imposed by earlier definitions of environmental psychology to consider the totality of physical and social environments in determining human behaviour and experience (Cassidy, 1997).

Environmental sociology developed as a complex new field to study interactions between the physical and social environment. Public opinion about the environment and environmental problems is an important factor that environmental sociologists consider a function of environmental conditions and social factors like scientific evidence, media attention and political influence. The primary interest within environmental sociology are conflicts in the use of the environment as a living space, supply depot and waste repository and concern, that the total human demand may be exceeding the carrying capacity of the local and/or global ecosystem, which questions the sustainability of modern industrial societies (Dunlap, 1994; Vitousek et al., 1997).

The study of perception in cognitive psychology also attempts to explain how we become aware of information in our environment, how we process that information and how we give meaning to that information which governs our response to it one way or another. A number of influential theories have been developed in this area (Gibson, 1979; Gregory, 1966; NEIA ser U., 1976). One area related to this study is *environmental data communication*, with the emphasis on scientific data perception and understanding. For many consider scientific literacy as an essential part of public understanding of environmental data. Historically, science was a specialized discipline reserved for the few who did not expect the majority to be familiar with the concepts, methods and recent developments in the world of science and technology (Cvetkovich and Lofstedt, 1999). It is now considered desirable that all citizens have an elementary familiarity with and understanding of science, although Korzybski (1958) shows that our industrialized society does not believe in scientific data as a way of determining truth. He claims that science is only used when the culture benefits from it.

Developments in science-based industry are having a growing impact not only on the material life of all humanity, but also on its ways of thinking. Knowledge and awareness of science and technology is becoming increasingly necessary in arriving at important individual, social, and political decisions (Rakesh, 1999). Recent emphasis in environmental data communication has been phenomena of *risk perception and risk communication*, which began in 1970 in analyses of the risks posed by nuclear power plants. Early studies of risk perception demonstrated that the public's concern could not be blamed on ignorance or irrationality. Researches show that the level of risk is only one among several variables that matter to people in evaluating and interpreting risk information (Covello, 1998).

Environmental economics, which grew out of classical economics, attempts to assign quantitative values to the goods and services provided by environmental resources, whether or not market prices are available. The economic value of environmental resources is based on our willingness to pay and it describes the value of the resource in providing such commodities, whether or not we actually make any payment. Methods for environmental evaluation consider observed and hypothetical human behaviour. There are many controversies surrounding valuing nature since values are relative, dependent upon context specific tradeoffs that people are willing to make among viable alternatives. Environmental values combine ethical and economic aspects with implications for policy and decision-making. A representative political and deliberative process can capture the ethical, religious, scientific and political factors that lead people to support or oppose a particular social or environmental policy (Farrow, 2000). In economics, valuations concepts relate to human welfare, where human welfare is measured in terms of the individual's own assessment of well being. Economic valuations take into account people's moral and cultural judgments and convictions about planned developments and express it with monetary value (Sagoff, 2000). Bromley (1999) explores some of the principal connections between the environment and development and seeks to explore the character and limits of the liberal, market-based approach to reconciling environmental and developmental objectives. He argues that, while there is much to learn from the market-based approach, it is inherently limited to a restricted notion of the appropriate scope of public action, both nationally and globally and that environmentally sustainable development will require the elaboration of a more developed account of the role of public action in protecting the environment.

The holistic approach to environmental management - Ecosystem Approach - started to develop in the last few years and is seen as a key to delivering sustainable development. Humans are considered a part of the ecosystem in this approach and new EU environmental policies are being developed based upon these principles. One of the most important parts of an ecosystem approach is the setting up of societal goals in which public participation is essential part of it and where individual disputes need to be put aside in a context of decisions that affect public life and where public discourse needs to be a continuous and an ongoing process (Laffoley, 2004).

2.2 Relevant research in Slovenia

Slovene sociologists have performed studies of the interactions between people and their environment since the early seventies. Researchers at the 'Centre for public opinion research' conducted public opinion polls on attitudes toward the environment, quality of life, values, national identities, religion and other issues (Toš, 1993, 1997, 1999). Many studies were made also in the area of spatial planning in an attempt to solve problems concerning town developments and road construction (Bartol et al., 1998, Polič, 1999). Trstenjak (1984) wrote the first book on environmental psychology, although earlier psychological studies are to be found in the area of psychological aspects of natural disasters or accidents, and of attitudes toward the environment, its degradation and waste management (Polič, et al., 1981).

Drevenšek (2002) addresses environmental public relations, with an emphasis on the influences and changes in understanding the relationships between society and nature. This research was intended for public relations' specialists, who understand that attitudes to environmental problems are socially constructed and that situational analysis of the public should be included in their practical work. Communicational problems reflect also in people's trust in legitimacy of the legal and political system (Igličar, 2000). One conclusion was that public relations should be improved and become a part of strategic management, since public opinion is an essential component of civil society and its legal culture (Ašanin Gole, 1999).

The search for radioactive waste repositories led to a significant amount of research on the so-called NIMBY (not in my back yard) phenomenon, which is related to the risk perception of the local community. Research shows that the lack of communication capability demands the inclusion of a social and psychological analysis of the local environment before there is any environmental intervention, since risk perception is by no means connected solely to the technology in question but is socially constructed (Pek Drapal and Kos, 1999).

In the Koper municipality, social research was made in the area of spatial planning due to the number of conflicting interests, rising from unsolved ownership and urban problems. These problems arise mostly from one-sided, market oriented land use solutions and from weak inclusion of public interest. The conflict of interests regarding future development of the Slovenian coast was also analysed (*Rus, 1990; Balaban, 1998*). Special sociological research was performed in the area to predict what the expected physical and social changes might be in future decades. Surveys addressed territoriality of residents, their local or national identification, habits in residential areas and attitudes toward emigration (*Mlinar, 1998*).

3. THEORETICAL STRUCTURE OF THE RESEARCH

3.1 Theoretical basis

The functioning of society as a whole and the individual as a unit is very complex. If we map the mutual influence of the physical environment onto the social and economic interests of society (or individuals), the identification of patterns becomes difficult. Dunlap wrote: "*Reality seldom falls within the boundaries of only one discipline, exclusive of all other*" (Dunlap, 2002, p. 16) and identified a number of special fields in sociology only, which traverse boundaries: social psychology, political sociology, economic sociology and especially environmental sociology.

Stern et.al. (1995) proposes a model that ties together position in social structure, values, general beliefs, specific beliefs and attitudes, behavioural commitments and behaviour with the claim that people do not hold attitudes, values and beliefs as separate items since they are organized into belief systems (from Bechtel, 1997, p. 124). Values, attitudes, beliefs and belief systems are ways we have of organizing our knowledge and responses to the environment around us and they arise as a response to environmental and social conditions (Bechtel, 1997, p. 108-152) (Fig. 3.1).

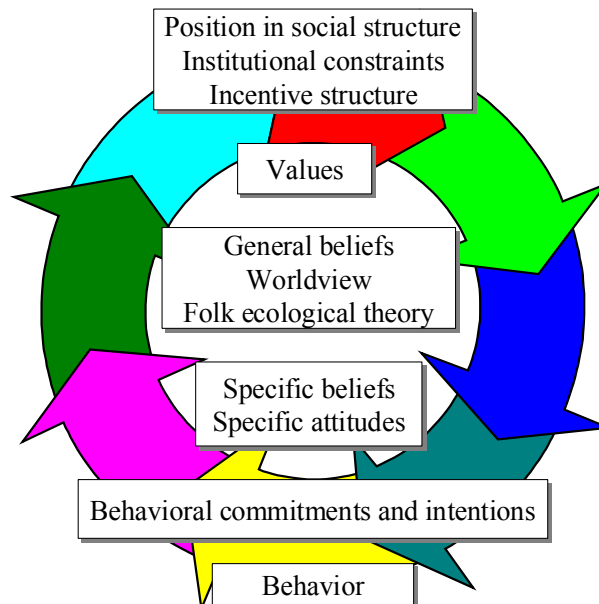

Fig. 3.1: Stern et. al.'s Causal Model of Environmental Concern, 1995 (from Bechtel, 1997)

Basically, all environmental problems arise from human unsustainable behaviour towards the environment. Weigel and Newman (1976) claim that once an attitude is known, a person's behaviour, as a pattern, is predictable. In reality, the correlation between attitudes and behaviour is not straightforward, for example, people may lie about their attitudes such that it becomes difficult to know what their attitudes were in the first place.

Beside the moral, personal or ideological reasons governing people's attitudes toward the environment, *institutional constraints* play an important role. Institutional constraints are a set of social rules, roles and relationships that act as guiding principles for major activities in society and include education, economy, cultural media, family and personal values and beliefs. Societal institutions are dependent on economic growth and production expansion. These two trends, strongly supported by societies are the main cause of conflicts in the use of the environment as living space, supply depot and waste repository and in influencing people's attitudes toward environmental protection (Dunlap, 2002, p.10).

It is the interaction between beliefs and attitudes, as well as the interaction with underlying values and opinions we may hold that makes attitudes difficult to observe and measure - we can only ask people or infer their attitudes from what they do (Bechtel, 1997). The definition of *attitude* is as a predisposition to classify objects and events and to react to them with some degree of evaluative consistency. According to theory of *cognitive consistency*, we all actively strive to be consistent in our attitudes, beliefs and behaviours. Any inconsistency acts as a stimulus to change them to bring them back into a coherent whole (*The New Encyclopaedia Britannica, 1992, Vol. 1, pp.687*); attitudes are also resistant to change by propaganda, advertising or any other means for different reasons that are likely to have arisen at an early age and became virtually personality traits. Although people's attitudes may be difficult to change, it is not impossible - in a study conducted by Rokeach in 1968 (Atkinson et al, 1990) he was able to demonstrate that once individuals are warned and are aware of possible inconsistency in their belief system, they are ready to adjust their attitudes. People learn what to do in different ways: through mental processes intervening between perception of a stimulus and decision to respond to it, by observing the consequences of other people's actions and through a self-evaluative process that involves people asking themselves, if their conduct is satisfactory (Skinner, 1953).

The definition of perception adds more controversies to the scheme, since the literature defines it as the complex method of obtaining information about our surrounding world and apprehending this information as beliefs, whereas environmental perception is defined as the way people look at and understand the Earth and its systems. Perceiving is subject to the influence of learning and may be influenced by people's expectancies, needs, unconscious ideas, beliefs, values and conflicts (*The New Encyclopaedia Britannica I, (1992), Vol. 9, pp. 279*).

Belief is defined as a mental attitude of acceptance or assent toward a proposition without the full intellectual knowledge required to guarantee its truth. Believing is either an intellectual judgement or a feeling with overtones that differ from those of disbelief. Beliefs are distinguishable according to their degree of certainty: a suspicion, an opinion or a conviction. Belief however only becomes knowledge when the truth of proposition becomes evident to the believer (*The New Encyclopaedia Britannica I, (1992), Vol. 2, pp.63*).

Numerous articles and surveys highlight the importance of trust to information sources, especially in the phase before people's attitudes have crystallized (Frewer, 1999). Definitions of social trust are various, from basic in Webster's dictionary, which defines it as "*assured reliance on the character, ability, strength, or truth of someone or something*", to more specific, given by social scientists. Cvetkovich and Lofstead (1999) developed theory that trust implies a difference in power and control. A person who trusts relinquishes decision and behaviour control to the one who is trusted. The trusting person trades behavioural and decision control for cognitive control while at same time selecting who is to be trusted (p. 4-5). Earle and Cvetkovich (1995) state that the basis of social trust is value similarity (*Salient Values Similarity theory*), a theory that states we trust those who are judged to share with us values we consider appropriate in a particular risk management domain. Democratic public cooperation is a powerful mechanism for building social trust, but according to Inglehart (1997, p.163) this requires several societal conditions to be fulfilled. These conditions include that individual disputes be put in a context of decisions, which affects public life. Public discourse needs to be continuous and an ongoing process and people must be empowered to enter into decisions and to see the results implemented.

People are dependent on the natural environment for meeting all their needs, and therefore the interactions between people and the environment cannot be separated. The challenge is to use and manage available resources, so that human and environmental needs can be met, now and in the future. The way, people perceive their needs and environmental impacts of their actions depend on many factors, from which we consider the moral responsibility to nature and environmental issues (environmental ethics) of the major importance in individual and corporate culture. Since classical ethics deals mainly with human-human relationships, the lack of ethical norms in relation to human nature is still evident and is addressed in many fields, including environmental ethics, environmental anthropocentrism and environmental obligation. The most radical approach to environmental responsibility is eco-centrism, which argues that the

environment has inherent worth and direct rights, qualifying it for moral personhood (Jameson, 2001). Ethical theories still did not bring satisfactory definitions for relation human - nature. Philosophers claim, that one of the main problems is that the human attitude towards nature is instrumentalist and that nature is therefore considered an object, which has no autonomic value and humans therefore have no moral obligation toward it (Ošljaj, 2000, p. 12). Another view on environmental ethics, also presented in Ošljaj is the view of Jonas (1979), who defines the human attitude towards nature through a direct connection i.e., nature as a source of means for humans, an idea similar to environmental anthropocentrism. Jonas however puts the emphasis on human's direct dependence on nature, where the attitude to nature should derive from the question "to be or not to be" that is from a human responsibility for future generations perspective. This kind of definition seems to be broadly acceptable, since the basic definition of sustainable development (*The Bruntland Report, 1987*) in modern society emphasises the urgent need for this kind of human societal responsibility.

Another important factor that shapes human attitudes to environmental issues is *religion*. In many religions the earth is only a place we will use temporarily and then move on, which could account for a basic disregard for the natural world and its life support systems - opinion that we are simply passing through terrestrial life makes the world a disposable item (White, 1967). Although critics of White claim, that Judeo-Christian teaching has only a small contribution to the environmental problems, White writes that "*what people do about their ecology depends on what they think about themselves in relation to things around them. Human ecology is deeply conditioned by beliefs about our nature and destiny - that is, by religion*" (pp.188). The truth about the Western Christian influence on attitudes towards nature probably lies somewhere in the middle of two extreme positions. At one end is the view that human stewardship of creation is a central theme in the Genesis stories of creation. The doctrine that God created humans in his self-image is important And that for centuries, many Christians have taken a positive view of nature - the special relationship that humans have with God means, that humans are called by God to be wise stewards, or caretakers, of the Earth. At the other end of the spectrum is that view that Genesis can be interpreted as providing a justification for the exploitation of nature with no regard for the consequences of that exploitation. When God talks about human creation, he says, "*Let us make humankind in our image, according to our likeness and let them have dominion over the fish of the sea, and over the birds of the air, and over the cattle, and over all the wild animals of the earth, and over every creeping thing that creeps upon the earth.*" (Genesis 1:26) and this is what leads White (1967) to conclude that this "monarchy" of humanity over the rest of creation is the culprit for a Christian attitude that denigrates the importance of nature.

3.2 Research questions

This research is designed to investigate:

- (i) the influence of information provided in the EIA process on opinions about environmental impacts of the Port of Koper,
- (ii) the possible influence of institutional constraint, i.e. employment to shaping opinion.

To take into account some of the complexity of interaction between human activities and environmental issues while eliminating possible influences of extraneous factors like group structure (gender, age, employment, education) or in respondents intrinsically held values and beliefs, we use a combination of several secondary hypotheses to investigate perception of environmental issues in coastal zone, the predominant social paradigm in society together with opinions and attitudes toward the environment and environmental issues, the degree of trust in information sources and opinion on the effectiveness of the information modes used in the process, the possible influence of institutional constraint on the results and the influence of the information provided in the EIA process.

Two basic research questions are therefore set to identify the differences between a group of people economically bound to the industrial activity under investigation (employees) and the general population.

The two questions are:

- *Is it possible to influence public opinion by information provided in EIA process?*
- *Does being economically dependent on a certain technological activity influence perception of environmental issues, related to that technological activity?*

3.3 Hypotheses definition

The primary null hypotheses, deduced from the basic research questions and which assume that there are no differences between groups, are:

- (i) *Public opinion does not change significantly after presentation of scientifically obtained environmental data connected to an industrial activity, since they have their own values,*
- (ii) *Economic dependence on a certain technological activity (institutional constraint) does not influence public perception of environmental issues.*

As stated previously, the study uses a series of secondary research hypotheses to identify the extraneous sources of possible differences in the opinions held between the two primary groups. The secondary research hypotheses are:

- People from different groups trust the same sources of information, consider the same sources as reliable (i.e. reporters, NGO, governments, industry, experts) and have the same preferences for information modes (i.e. TV, internet, radio, newspapers, public presentations).
- Population and employees have similar priorities in the Port of Koper development.
- Value structure on which society depends is similar for all groups.
- People with a different level of education, different social status, age and gender have a similar level of readiness to risk material safety to protect the environment.
- Perception of environmental issues in the coastal zone regarding environmental quality is similar for all groups.
- Perception of the Port of Koper environmental impact is similar for all groups.
- Moral responsibility to environmental issues and the extent of trust in technological development and technological solution of environmental problems is similar for all groups.
- Public readiness for participation in environmental protection is similar for all groups.

3.4 Research outline

The research consists of three steps:

- A survey to analyse public opinions on environmental issues in the coastal zone together with opinions about their priority values, trust in technological development, their feeling of moral responsibility towards the environment and their readiness to participate in environmental protection;
- A presentation in EIA process – release of the environmental information about an industrial activity and its' environmental impacts;
- A second survey conducted using the same set of questions as in the first except that it has an added set of questions to examine the effectiveness of environmental data presented during the EIA process.

Two groups of respondents were constructed made of employees and respondents from the general population. Since it is not possible to test the informed/uninformed (control) group in this case, we analysed the influence of the EIA information by using two surveys in time series. Random assignment of individuals to the sample groups from different locations of residency and employees avoids sources of invalidity (Fig. 3.2). The time series approach is based on the comparison of gain scores: how much difference in gain or loss is there between the groups using measures before and after information release.

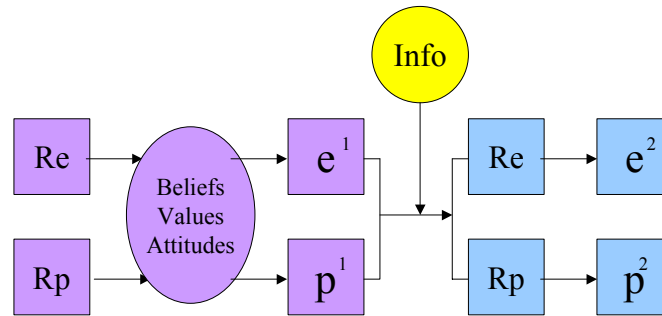

- Rp - random sample from respondents from general population of people in surrounding, older then 18 years
- Re - random sample from the population of employees
- e¹, p¹ - observations of groups after the 1st survey
- e², p² - observations of groups after the 2nd survey

Fig. 3.2: Outline of the research

The initial survey enables an analysis of the predominant social paradigm in society together with certain opinions and attitudes towards the environment and environmental problems. It is actually a cross-sectional study of selected populations, which shows a correlation between variables to describe the outcomes. The focus is on the possibility of relationships between pairs of variables. All results are controlled for possible influence of extraneous variables (gender, age, employment, education structure and location of residency).

The “intervening variable” is the presentation of the industrial activity and its’ environmental impacts in EIA process, performed as the second step of the research.

The third step involves a second survey, after the release of the EIA information. Final data aggregation, quantification, comparison and statistical analysis of both surveys are used to show to what extent the environmental information influences the opinions of both subject groups.

To test the hypotheses, differences in opinions between employees and the general population, living in the activities locality are analysed to identify the influence of institutional constraint and information release on environmental data perception.

4. METHODOLOGY

4.1 Design of the research

To answer the specific research questions the study needs to:

- identify basic statistically significant differences among assigned groups of people in their opinions, beliefs or attitudes;
- investigate the changes over time in the opinions before and after the information release;
- control results for possible influence of extraneous variables;
- identify possible causal links between dependent and independent variables.

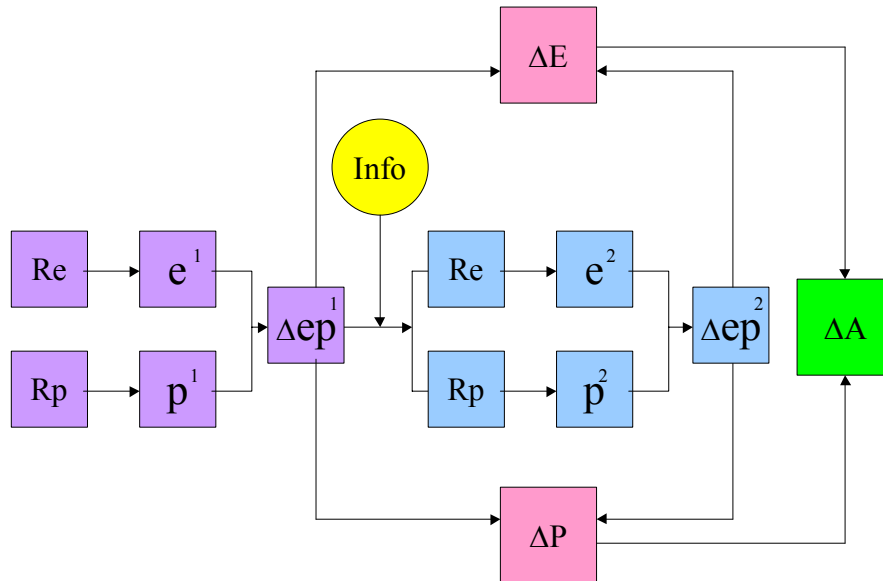

- Rp - random sample from the general population
- Re - random sample from the population of employees
- p¹ - existing opinion of respondents from general population
- e¹ - existing opinion of employees
- Δep¹ - difference in opinions between employees and general population in the first survey
- Info - information for the public
- e² - opinion of employees after the information release
- p² - opinion of the general population after the information release
- Δep² - difference in opinions between employees and general population in the second survey
- ΔE - difference in opinions in the group of employees before and after the information release
- ΔP - difference in opinions in the groups of general population before and after the information release
- ΔA - observed difference before and after the information release

Fig. 4.1: General course of research

We used pre- and post-test design, instead of the classic research design, which proposes the use of case – and control groups, where the only difference between the two groups would have been the information provided to case group. The reasons for not using this classic design are twofold:

- (i) The EIA process is designed on a premise that everybody should have a possibility to participate in it and should also have access to the information, provided in the process.
- (ii) It is not possible to establish a control group. Namely in the present information society it would be difficult to claim, that group of respondents from the control group did not see parts of information on TV or got information from other information sources.

Research consists of four steps. Three of them are presented in a model on Fig. 4.1. The last – fourth step is presented on Figure 4.2.

1st part of the research:

- clustered random sample selection from the general population at selected locations in the surrounding of the presented activity - R_p and a random sample selection from a group of employees of the activity - R_e ;
- measurement of variables in survey research, looking at pairs of values or observations for each subject (e^1 and p^1). There is no control over possible extraneous variables and so the method design involves observing their potential effects on measured outcomes;
- identification of differences in opinions between the two groups - Δep^1 .

2nd part of the research:

- EIA report preparation and presentation (Info).

The EIA report serves as a comparison of the survey results to investigate the level of knowledge in the society. The information process is considered here to be a stimulus, which is processed and compared by pre-existing concepts of the perceiver. According to the Gestalt approach in psychology these concepts will shape the response to provided information, therefore the whole context must be taken into account in studying perception, as opposed to a piecemeal study of individual elements, since both - the person and the environment contribute to perception.

The processing of environmental information can be broken up into stages: (i) awareness of the environment (what we pay attention to), (ii) perception of the environment (how we make sense of stimuli) and (iii) environmental knowledge (organized information), including cognitive maps. As Ule A. (2001) states, we are all searching for the certainty in knowledge. This can be applied to the development of science and to everyday life. But instead of being more certain in the information and scientific evidence, we encounter many uncertainties in knowledge, especially in predictions of events or consequences. EIA process also involves prediction and thus uncertainty is its part. In the present information society, with the rapid circulation of information, we encounter also a lot of scepticism, which reflects in disbelief in provided information.

Ule (2001) also states that knowledge can not be explained by possession of information, since knowledge is based on past and present cognitive process, therefore results can not be taken absolutely, but must be interpreted in the view of accompanying uncertainties and limitations of our understanding of the process.

3rd part of the research:

- a second survey after information release. In this survey the sources and modes of information, regarded as the most effective and reliable in the process were identified. The method applies the same sample and the same process as in the first survey.
- identification of the observed differences in opinions between the two groups – Δep^2 .
- identification of observed difference between the results of the first and second survey for each group of interest – ΔE and ΔP together with differences observed between both groups before and after the information release - ΔA (Fig. 4.2).

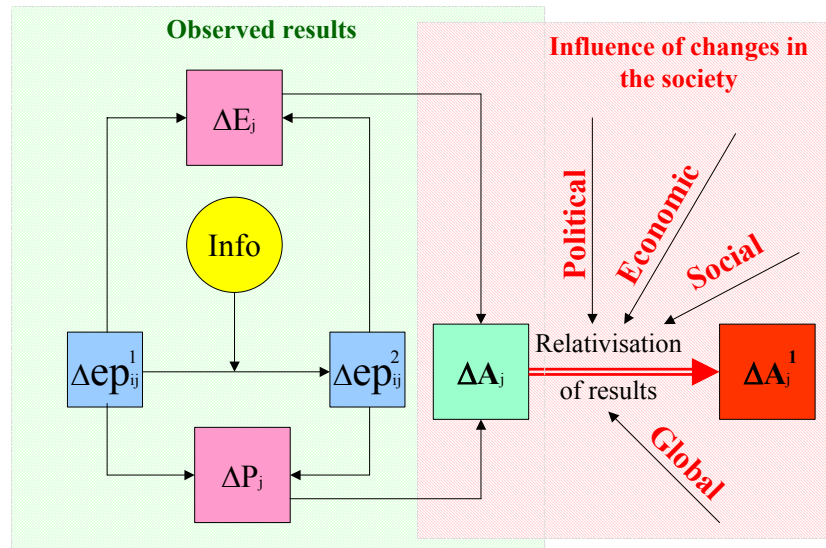

- Δep_{ij}^1 - difference in opinions between employees and general population in the first survey
- Info - information for the public;
- Δep_{ij}^2 - difference in opinions between employees and general population in the second survey;
- ΔE_j - difference in opinions in the group of employees before and after the information release;
- ΔP_j - difference in opinions in the groups of general population before and after the information release;
- ΔA_j - observed difference in opinions between two groups before and after the information release;
- ΔA_j^1 - difference in opinions between two groups before and after the information release, assigned to information provision only;
- IS - influence of changes in the society – regional national and global economic, political and social changes;

Fig. 4.2: Data aggregation

4th part of the research:

- identification of the possible influences of the changes in the society, economy, politics, global changes and other social changes over time (IS),
- description of difference in opinions between two groups before and after the information release, assigned to information provision only, where $\Delta A^1 = \Delta A - IS$.

Since the influence of the changes over time in the society could not be quantitatively determined, differences in opinions between two groups, assigned to information provision only were described semi-quantitatively in the view of uncertainties, brought in by social, political, economic and global changes in the time of the surveys.

4.2 Variables definition

There exist two main comparison groups - *the general population* who represent local residents older than 18 years and *employees* who comprise of people, economically bound to the activity.

The independent variables are factual data about the population (employees / general population group): gender, age, education, employment and residency. These factual data are the extraneous variables, since different population group's structure can influence the outcome.

Dependent variables are phenomena to be explained and are compared for each group i.e., for each independent variable:

- opinion on sources of environmental information and trust in these sources;
- opinion about priorities in development of the activity under investigation;
- value structure on which society currently depends;

- readiness of society to risk material safety to protect the environment;
- perception of environmental issues in the coastal zone;
- opinions on the activity's environmental impact;
- moral responsibilities towards environmental issues and the level of trust in technological solution of environmental problems.
- the extent, to which people are ready to participate in environmental protection.

The *intervening variable*, which comes between two measures of dependent variables in time, is the information provided in EIA process to both groups.

4.3 Variables association

The association among independent variables and dependent variables is defined below. Associations are the same in both surveys (Fig. 4.3).

The *independent variables* - attributes of respondents groups, on which presented research has no influence, are marked as:

- X_1 - general population,
- X_2 - employees.

Extraneous variables are sources of possible differences in opinions, which are not of primary interest in the research, but can contribute to an explanation of the differences between the two main groups. They represent the different structure of the general population/employees groups:

- X_3 - gender,
- X_4 - age,
- X_5 - level of education,
- X_6 - employment and
- X_7 - location of residency.

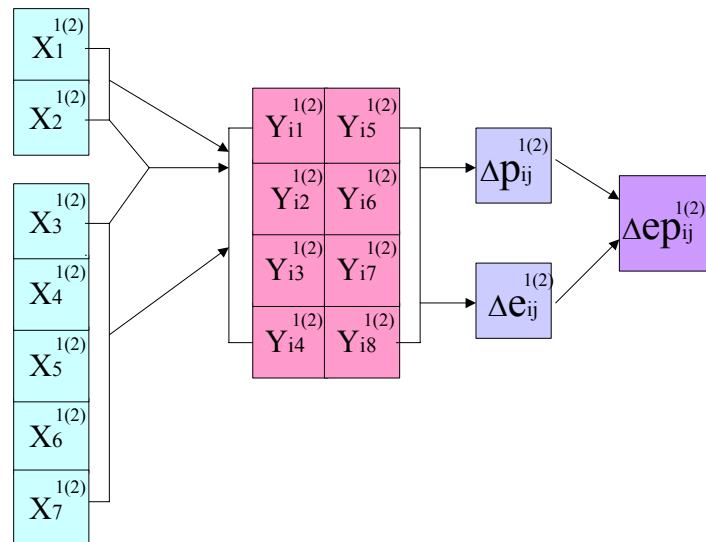

- $X_1^{(2)}$ - independent variable - members of general population
- $X_2^{(2)}$ - independent variable - employees of the selected activity
- $X_3^{(2)}$ - $X_7^{(2)}$ - extraneous variables
- $Y_1^{(2)}$ - $Y_8^{(2)}$ - dependent variables
- $e_{ij}^{(2)}$ - results for dependent variable - employees
- $p_{ij}^{(2)}$ - results for dependent variable - general population
- $\Delta ep_{ij}^{(2)}$ - observed difference between results for dependent variables
- $\begin{matrix} (1) \\ (2) \end{matrix}$ - first or second survey results
- i - index, marking results from certain question from the questionnaire ($i=4 - 18$)
- j - index, marking the variable ($j=1-8$).

Fig. 4.3: Survey design

The following indicators represent dependent variables:

- Y₁ – opinion about sources and modes of environmental information;
- Y₂ – priorities in industrial activity development;
- Y₃ - value structure on which society depends;
- Y₄ - readiness of society to risk material safety to protect the environment;
- Y₅ – perception of environmental issues in coastal zone;
- Y₆ - opinion about the industrial activities' environmental impact;
- Y₇ – moral responsibility and trust in technological solutions of environmental issues
- Y₈ – readiness of a population to participate in environmental protection.

Question of religion was not included in analysis because of its possible double role, identified in Chapter 3.1.

Each variable is measured by the outcomes of matching questions on the questionnaire. Association between variables (Y₁-Y₈) and questions (Q₄ - Q₁₅) is presented in Table 4.1., divided between two main groups (e - employees, p - general population).

Table 4.1
Association between questions and variables

Questions 1 st survey	Questions 2 nd survey	Variables	Variables description
Q4	Q4, Q14, Q16, Q17	$iY_{1e}^1, iY_{1e}^2, iY_{1p}^1, iY_{1p}^2$	- opinion on sources and modes of environmental information
Q5	Q5	$iY_{2e}^1, iY_{2e}^2, iY_{2p}^1, iY_{2p}^2$	- priorities in activity development
Q6	Q6	$iY_{3e}^1, iY_{3e}^2, iY_{3p}^1, iY_{3p}^2$	- value structure on which society depends;
Q7	Q7	$iY_{4e}^1, iY_{4e}^2, iY_{4p}^1, iY_{4p}^2$	- readiness of society to risk material safety to protect the environment;
Q8-Q11	Q8-Q10, Q18	$iY_{5e}^1, iY_{5e}^2, iY_{5p}^1, iY_{5p}^2$	- perception of environmental issues in the coastal zone;
Q12	Q12	$iY_{6e}^1, iY_{6e}^2, iY_{6p}^1, iY_{6p}^2$	- opinion about activities' environmental impact;
Q13	Q13	$iY_{7e}^1, iY_{7e}^2, iY_{7p}^1, iY_{7p}^2$	- moral responsibility and trust in technological solutions to environmental issues;
Q14	Q15	$iY_{8e}^1, iY_{8e}^2, iY_{8p}^1, iY_{8p}^2$	- the willingness to participate in environmental protection.

The results consist of a qualitative description of the variables' influences, based on quantitative results, and checked for significance by statistical methods.

In addition $\Delta p_{ij}^{(2)}$ is discussed in terms of other, outer influencing factors, not controlled in the research. Theoretical philosophy is still trying to explain relations between knowledge, perception, beliefs, cognition and logic (Ule, 2001). Similar efforts are still ongoing in environmental behaviour science (Bechtel, 1997). Therefore any interpretation or explanation of perception can be taken just as another step in the ongoing process of the efforts to understand human society.

4.4 Hypothesis testing and significance

The purpose of hypotheses testing is to investigate if sample results hold true in a population and to decide whether the differences are significant. The use of probability theory to test hypotheses formally permits inferences from a sample to population and test, whether descriptive results are likely to occur due to random factors or to a real relationship. The level,

chosen for statistical significance in this research is 0,05, since a 95% confident interval is an acceptable standard for explaining the social world (Black, 1999). Hypotheses are tested for all groups, where the main two groups are made up from the general population or employees. Extraneous variables considered in research are:

- education,
- gender,
- age,
- employment,
- residency.

The hypotheses for the comparison across measures are:

- H_0 : The distributions are the same;
- H_a : The distributions are different.

Non-parametric tests for hypothesis testing are used, because they are not dependent on sample distribution.

Friedman test

The Friedman test is the nonparametric equivalent of a one-sample repeated measures design or a two-way analysis of variance with one observation per cell. Friedman tests the null hypothesis that k related variables come from the same population. For each case, the k variables are ranked from 1 to k . The test bases statistic on these ranks. The Friedman test was used for hypothesis testing of question Q-4, Q-6 and Q-10, where the answers to the questions are related among themselves. The test was also used to analyse all questions for testing matched samples from different location of residency. Assumptions made by the Friedman test are that the test variables are at least ordinal and that their distributions are reasonably similar.

Kruskal Wallis χ^2 test

The Kruskal Wallis test is the nonparametric analogue of a one-way analysis of variance to detect the differences in distribution location and assumes there is no a prior ordering of the k populations from which the samples are drawn. It is a non-parametric distribution-free test used to compare three or more independent groups of sampled data. Kruskal-Wallis χ^2 is used to test the hypotheses in questions Q-5 and Q-11 to Q-14, for the independent samples and for ordinal dependent variables. Test does not assume normal data distribution.

Wilcoxon's signed ranks test

The Wilcoxon signed-rank test computes the differences between the two variables for all cases. If the two variables are similarly distributed, the number of positive and negative differences will not differ significantly. Wilcoxon signed rank test is used for comparison of the changes over time and to make a comparison of two matched samples. The test does not assume normal data distribution.

Spearman's ρ correlation coefficient

Spearman's ρ correlation coefficient is a measure of the association between rank orders. Correlation's are based upon pairs of measurement and provide an indication of the strength of the relationship between variables that represent characteristics of the group.

4.5 Instrument of measurement - questionnaire

Self-completion questionnaires were used for the surveys, since when asking people about their beliefs and values, a non-direct approach is recommended by sociologists. A straightforward question can all too easily evoke a rhetorical or ideological response but by asking people direct questions, answers given may also be more culturally acceptable. Where interviewers are involved there is always an element of personal reaction in the interaction, and it is difficult to use the same phrasing and intonation in every single case (*Black, 1999*). Closed questions are used as operational definitions for different attributes, designed with the intention of being operational definitions of concepts – dependent variables.

4.5.1 Levels of measurement

There is a mix of measurement levels among the independent variables: X_1 and X_2 are dichotomous (employed/non-employed), some of the control variables are dichotomous (gender, education, employment, residence) or interval (age - divided in 5 year groups). They are classified as nominal (gender, education, employment, and residency) and ordinal (age).

Likert scales are used for questions, which measure attitudes. Attitudes are ascertained by presenting a list of declarative statements, asking respondents to rate them in terms of agreement or disagreement. Scales are querying from 'strongly agree' to 'don't agree at all', scaled on 1-4. The total score is qualified and quantified as indicator of the attitude. For some questions rating scales are used, scaled from 1 to 5. By the use of rating scales the judgement is made on the level of opinion. Quasi-filtered questions are used, which offer a 'don't know' alternative, because also a non-attitude is an expression of attitude/feeling or knowledge.

The set of questions that can be answered 'yes' or 'no' are restricted to binary questions, because additional information can be acquired by asking for rating an event, perception or attitude.

4.5.2 Questionnaire

The questionnaire is divided into 9 parts (*APPENDIX 1 (1st survey) and APPENDIX 2 (2nd survey)*).

Questions asked in the 1st and 2nd survey

The association between questions and variables is presented in the Table 4.1.

Questions Q1- Q3 are intended to gather personal data about the respondent. These questions serve to define independent, factual variables - residency, gender, level of education and age.

Question Q4 inquires about the source of information and trust in information sources, where respondents are asked to rank different sources of information according to their trust in these sources (i.e. reporters, NGO, governments, industry, experts).

Question Q5 asks about priorities in industrial activity development and is designed to identify the basic differences in expectations and the concerns of the respondent groups.

Question Q6 investigates value structure on which society currently depends. Respondents are required to rank the following issues: clean and healthy environment, solid economy, economical growth, humane society and freedom of speech according to what the respondent believes are their importance for society.

Question Q7 investigates the willingness of society to risk material safety in order to protect the environment. Respondents are required to rank their agreement with the following statement: 'environment has to be protected even if it means fewer jobs in local community'.

Questions Q8 - Q11 are designed to show how respondents perceive the quality of the environment in the coastal zone and to identify the possible public misconceptions regarding environmental quality. Questions require respondents to rank the sources of air, marine and noise pollution.

Question Q12 investigates opinions on the environmental impact of the activity under investigation.

Question Q13 shows the extent of trust in technological solutions to environmental problems and the moral responsibility towards the environment. The study investigates opinion on the impacts of technological development and scientific progress on environmental quality, the level of respondents' eco-centrism, their belief in technological solution for environmental problems and concern for future generations.

Question Q14 to show the extent of which people are aware of their contribution to environmental quality degradation and their willingness to participate in environmental protection.

Questions asked only in the 2nd survey

The 2nd survey contains four additional questions (Q11-Q17) added to acquire information on which modes of information (TV, internet, radio, newspapers, public presentations) and sources of information (reporters, NGO, governments, industry, experts) were most effective and reliable. The sequence of questions was changed as presented in Table 4.1. (*APPENDIX2: Questionnaire 2*).

4.6 Response data evaluation

The relative differences in results between the assigned groups are the focus of this research; absolute results are of secondary importance. The dependent variables (Y_i) are operationally defined and are observable through measurable outcomes (Q_i). The inference made from the collected data in the survey to the dependent variables evaluation is calculated according to the frequency of response, respondent sample size and the rank given to the answers in the questionnaire. The study uses mean ranks or percentage results for quantification of results.

4.6.1 Data quantification

For an easier first overview and greater transparency of the results, the data are quantified and graphically represented. It is the total scores (mean/percentage) on sections of the questionnaire and not individual question scores that constitute numerical data. Questions, with the request to rank subjects according to their importance are graded from 5 = the most important goal to 1 = the least important goal. Questions with the request to rank the agreement or acceptance of subjects are graded from 4-1. The index for each question is represented by the mean of ranks (or percentage in some questions). Indexes calculated for independent variables are compared between selected groups.

Results are represented as a set of variables (Y_j), which are described on the basis of quantitative data, represented by indexes ${}_i y_j$ for each identified group.

- ${}_i y_{je}^1$ - existing opinion of the employees group is calculated from the results of the first survey;
- ${}_i y_{jp}^1$ - existing opinion of respondents from the general population is calculated from the results of the first survey;

- iY_{je}^2 - opinion of the employees group after the information release is calculated from the results of the second survey;
- iY_{jp}^2 - opinion of respondents from the general population after the information release is calculated from the results of the second survey;
- i - index, marking results from certain question from the questionnaire ($i=4 - 18$)
- j - index, marking the variable ($j=1-8$).

Difference for the 1st survey results between employees and general population Δ_{ep}^1 is calculated using equation:

$$\Delta_{ep_{ij}}^1 = iY_{jp}^1 - iY_{je}^1 \quad (1)$$

Difference for the 2nd survey results between employees and general population Δ_{ep}^2 is calculated using equation:

$$\Delta_{ep_{ij}}^2 = iY_{jp}^2 - iY_{je}^2 \quad (2)$$

Difference between 1st and 2nd survey results for employees ΔE_i is calculated using equation:

$$\Delta E_j = iY_{je}^2 - iY_{je}^1 \quad (3)$$

Difference between 1st and 2nd survey results for the general population ΔP_j is calculated using equation:

$$\Delta P_j = iY_{jp}^2 - iY_{jp}^1 \quad (4)$$

Common difference for both groups in both surveys ΔA_i is calculated using equation:

$$\Delta A_j = |\Delta P_j| - |\Delta E_j| \quad (5)$$

4.6.2 Data qualification

Quantitative data tables and graphs give an overview of results for each question, for each group in both surveys and for data changes. Statistical analysis of the results shows a statistically significant difference between groups or the changes over time and significant impacts of extraneous variables. Final data aggregation is performed qualitatively.

4.7 Validity of the research

4.7.1 Standardization

To apply measure in a standardized way, questionnaires are used and delivered to randomly selected respondents. Every respondent receives the same information about goals of the research. One of the disadvantages of posted questionnaires is that there is no one to explain to the respondent what the questions mean and what is required of them when answering the questions, so that the number of 'spoiled' responses or the amount of erroneous information due to misunderstanding is potentially greater. To overcome this problem the telephone number of a contact person was given in a covering letter.

4.7.2 Internal validity and reliability

Internal validity is ensured by the control of extraneous variables. Since the relationship between independent and dependent variables can be disturbed by the different structure of the two groups (e.g. age and gender), the influence of these variables on people's opinion is analysed to determine unequivocally the relationship between the two main groups.

Validity can also be improved by avoiding confounding due to the influence of other events in time by analysing groups, which are equally influenced by unknown extraneous variables over the time interval of the study. Both sample groups come from the same area, therefore we assume they were exposed to similar life events and information in the time between both surveys.

Sample stability can also influence internal validity. To avoid this problem the same random

sample was used for both surveys. Random sampling of subjects also ensures external validity, since results from a random sample can be generalized to a large population and real situations.

The first survey may in some way sensitise the participants in the experiment and make them more susceptible for environmental information. Sensitisation supposedly shows up equally in both groups and does not therefore influence the results.

Reliability of measurement (internal consistency) is calculated according to Cronbach's α coefficient, which is a reasonable indicator of the internal consistency of instruments that do not have binary marking schemes and is appropriate for questionnaires using a rating or Likert scales response (Black, 1999).

4.7.3 Construct validity

It is much more difficult to devise instruments that measure attitudes, beliefs and values than it is to measure achievement or intellectual skills. Attitudes can change over short periods, under different stimuli, and with the feeling of the moment, whereas skills and knowledge are much more stable.

How accurately we can infer people's attitudes from responses to questions are limited by a number of personal traits including:

- faking results i.e., the respondent answering in a way that he/she thinks will make either a good or bad overall impression. Communicating the purpose of the study and convincing subjects that the results will have no personal consequences for them may alleviate this. The covering letter is intended to eliminate this influence.
- social desirability results in answers that are in accordance with what the subjects think they should say rather what they really feel.
- bias towards either end, or the middle of rating on the Likert scale may indicate an inability to make decision or take a stand.
- misinterpretation of questions, local use of words or limited vocabulary of respondents can adversely affect the validity of the results. Piloting was performed in order to minimize this possibility.
- unusual, intentionally misleading responses can also distort results. If subjects are not convinced of the value of responding, this can occur.

Of course, not all these influences can be efficiently controlled, but by the use of random sampling it is expected that these influences be equally distributed.

4.8 Uncertainties

We used pre- and post-test design, which means that we have an uncontrolled contribution to changes due to 'external events'. In addition to the information provided in the EIA process, socio-economic and political changes during the period between both surveys may have influenced the results, beside the information provided in the EIA process. These uncontrolled changes could be due to (i) acquisition of additional knowledge about environmental issues or (ii) changes of attitude toward environmental protection due to economic, political, social and global changes in the society. We could not use the classic research design, which proposes the use of case and control groups. This method would, by definition, minimize impacts of unknown events on causal relationships between variables. However, in the context of the EIA process, which is designed on a premise that everybody should have a possibility to participate in it and should also have access to the information this could not be achieved. In the present information society it would be difficult to claim, that the control group of respondents did not see parts of information on TV or got information from other information sources.

We distinguish between systematic and statistical uncertainties. As stated in Kontic et al. (2001, p. 81) systematic uncertainties arise from negligence in the experiment design. Statistical

uncertainty is the finiteness of the input data ensemble and in terms of systematic uncertainty there are four levels groups, which should be considered.

The first level is related to the change of a parameter value, which we intend to measure, and its primary cause. In our case this is the influence of information provided in the EIA process on the perception of environmental issues. We are looking for causality between dependent and independent variables and try to isolate (control) the effect of the others. These are:

- sources of environmental information and trust in these sources;
- priorities in development of the activity under investigation;
- value structure on which society currently depends;
- readiness to risk material safety to protect the environment;
- moral responsibilities towards environmental issues and the level of trust in technological solution of environmental problems;
- the readiness to participate in environmental protection.

Other sources of systematic uncertainty – in our case general social influence, comprise of parameters with non-negligible sensitivity. Among these we controlled individual characteristics of respondents groups (gender, age, education, employment, location). According to the design, the research was not intended to control social and economic change in the society - which also brings systematic uncertainty, since this would require different approach to the study and is away from its primary aim. However, these uncertainties are expected to be equal for both groups and do not disable us to identify differences between the two groups due to information provision in the EIA process.

Statistical uncertainty occurs due to statistical variability of data. It is expected to have a small effect on results and will be quantified.

5. CASE STUDY

5.1 Environmental setting of the research

The only industrial port in Slovenia – the Port of Koper, was chosen as a case study since it is a complex activity with a long history of different environmental issues and dilemmas due to the Port's location in an urbanized area. The local community, government agencies and other interested parties are in conflict every time the Port authority wishes to start some new activity or make certain changes.

Coastal zone development

The Slovenian coast is mainly urbanized and the Koper Municipality is among the highest developed areas in Slovenia. Approximately, 15% of the coastline is preserved in the natural state, although human influence is pervasive and usually present. The process of urbanization is increasing the pressure on the environment with floor area per person rising by 40% in the time between 1971 and 1997. This is a result of higher living standards and the lower average number of persons per household. Floor area per person is higher in coastal zone than the national level. Population growth in the urban areas is higher than growth of whole population in the region and the urbanization rate in the coastal zone rose from 44% in 1948 to 63% in 1991, which is higher than national average (50,5%) (*EIONET, SORS*).

Number of cars per 100 inhabitants is 20-30% higher in the coastal region than the national average (0,4 car/person in 2001), indicating higher living standard. In the last 10 to 15 years the number of passenger cars per 100 inhabitants has risen substantially. Density of roads in coastal zone is also much higher than Slovenian average, indicating highest demand for road network along and in the hinterland of the Adriatic coast.

Within the coastal zone the nature is the most obvious tourist attraction and the number of daily visitors is increasing, especially during the weekends. The number of tourists remains stable, while their stay is getting shorter, which means higher number of cars in the area. Number of moorings in yachting marinas grew from 100 in 1978 to 1618 in 1998 (*EIONET, SORS*).

According to the data supplied by the Ministry for Agriculture and Forestry more than 400 ha of agriculture land in the coastal municipalities is irrigated. This demand for irrigation water is bigger than the local and regional water resources, especially in summer. Arable land per capita has decreased by 6 % from 1991 to 1996 with the main causes being road constructions and urbanization. After the adoption of a new law on the protection of the agricultural land, annual changes in the use of agricultural land decreased.

Wastewater treatment is still not fully functional but must be by 2010. The rate of treated/non-treated wastewater discharge from public sewage systems within the coastal zone changed from 40/60 % to 70/30 % in 1997- 2002. Unfortunately, the wastewater treatment plant in Koper does not function properly yet due to salt intrusions into the system.

Social aspects of Koper Municipality population

Due to governmental policy, there was a wave of emigration to the Slovene coastal zone after the Second World War and about 53% of inhabitants in the Koper municipality immigrated to the area during that time. The population of the City of Koper changed almost completely, while the endemic population remained in smaller villages like Bertoki or Hrvatini. A survey by *Mlinar, 1998* shows how the endemic population became a minority in city centres, a situation different than seen in other areas in Slovenia. The survey shows also that most people declaring themselves as "endemic" are from youngest generation, whereas only 21% of older people in

the area declare themselves as “endemic”. During this period, young people showed a strong tendency to move away from the area to gain an education or employment elsewhere.

A comparison of research about territoriality reveals people in Koper region to display a stronger attachment to their municipality and region than people in other regions of Slovenia, who in general display a stronger attachment to Slovenia. This high level of attachment to the local area does decrease with the education – so that among those with higher education the smaller is the sense of territoriality (*Mlinar, 1998*).

Population employment rate

There are about 39,6% of employed people among the population of Slovenia. Unemployment rate in 2001/2003 was 11,6/11,2% (Slovene methodology) or 6,4/6,7 (International Labour Organisation methodology), while unemployment in Koper municipality was 10,1%.(Slovene methodology) in 2003. Statistical data on the movement of registered unemployed by the Employment Service of Slovenia shows that number of employed people changes seasonally. 42,9% of the whole population is employed in the Koper area. (*EEIONet, SORS, Employment Service of Slovenia, 2003*) (*APPENDIX 3*).

Population education

Education structure in Slovenia has changed in the last 10 years, especially in number of people with no schooling and with finished secondary school. The number of people that finished secondary school rose from 42,9% in 1991 to 55,3% in 2001, while the number of people with either a degree or a graduate education rose from 8,9% to 13,0%, over the same time period (*SORS, 2001*).

Statistical analysis shows, that Ankaran (15%) and Koper (14%) have a lower number of people who failed to finish primary school than the average in Slovenia (17%), whereas this number is higher than average in other locations - the highest is in Bertoki (29%) and Zg. Skofije (26%). The number of people that finished secondary school is higher than in the average population (43%) at all locations (44%-47%), except in Zg. Skofije (38%). The number of people, with high and higher education is highest in Ankaran (16%) and Koper (15%), a figure that is much higher than the national average (9%). These numbers are lower in Zg. Skofije, Hrvatini (6%) and Bertoki (8%). (*SORS, 2001*)

Population gender and age structure

The population of Slovenia declined during the 1990's falling from 1.999.945 in 1990 to 1.975.292 in 1999. This trend now looks to be changing now, and the data from 2004 show a slow growth to 1 996 370 inhabitants (index 1,010), despite the total fertility rate dropping from 1,42 in 1991 to 1,20 in 2003. The gender structure is divided male/female = 51,5/48,5% and while the statistical data shows that more boys than girls are born every year (index boys/girls 1,057), by the age of 50 the proportion of genders equals and changes such that the index of male/female population of age 60-64 =0,88.

Population growth in Koper municipality is slightly higher than national average with the population increasing from 46.391 in 1999 up to 46.974 in 2002 (index 1,012). Gender structure in the Koper municipality is similar than in the rest of the county, but age structure is different. There is a lower proportion of children and a higher proportion of the older generation, which is probably due to people moving to the coastal zone after retirement age and to the fact that the government supported the movement of people to the coastal zone during the 1950's for political reasons (*EEIONet, SORS*). Another reason for different generations structure may also be a tendency of young people to find higher education elsewhere. If we compare age structure of Slovene population to populations at chosen locations, we find a similar pattern, although due to small number of inhabitants in the area some differences occur.

Population density in the coastal zone is double the national average (232 inhabitants/km² compared to a national average of 98 inhabitants/km²). Over 80 % of the population within in coastal zone lives within 1.5 km from the coast. General population parameters are presented in APPENDIX 3.

Environmental issues in coastal zone

Air quality

The coastal zone has a good self-cleaning capacity due to the open configuration of the bay and frequent winds. Regular state monitoring in Koper is performed on 24-hour basis and smoke concentrations (LV=125 µg/m³) and gaseous acid air pollution (LV=125 µg/m³) measurements do not exceed set limit values (LV). Monitoring of ozone O₃ (LV_{8 hours}=125 µg/m³), NO₂, particulates, volatile organic compounds VOC, formaldehyde, carbon monoxide CO and sulphur dioxide SO₂ were performed in 1999 over a 24 day period (REP, 1999). Results show, that only ozone concentrations exceeded the 8 hours LV and that these values correlate to road traffic (ES, 2003; REP 2003; Spes et.al., 1998).

Marine quality

The sea in the Bay of Trieste is shallow, semi-enclosed bay, where the marine water is replaced every 5-8 years due mainly to river inflow. The main characteristics of the sea regarding its natural cleaning capacity are that the circulation of water is very slow and river sediment input is high and brings with it large amounts of both nutrients and pollutants. According to trophic index measurements (TRIX = 2,7÷6,3) the bay is an oligotrophic to mesotrophic area. Regular monitoring of marine quality in the Koper area occurs 4 times per year measuring a series of physical and chemical parameters including the trophic index TRIX, Phytoplankton (Chl a), Cd, Hg, polyaromatic hydrocarbons (PAH) in water are measured. In addition monitoring also includes measuring PAH, Cd and Hg in sediments and shellfish tissue.

A long-term study reveals the main source of marine pollution in Koper area to be outflows from Koper wastewater treatment plant and untreated wastewater, which flow into the sea *via* the Badaševica and the Rižana Rivers. PAH concentration in the sediments at the open sea are 0,9 µg/g while being 1,9 µg/g for aliphatic hydrocarbons. These values correlate due to nautical tourism and other marine traffic, including marine traffic from the Port of Koper and Port of Trieste (NIB 1997-2001).

Noise pollution

The main source of noise in the coastal zone is traffic, which in some areas exceeds statutory limits. Traffic results mainly from tourism, industry, the Port of Koper and agriculture. Statutory limit values differ diurnally for the different areas according to land use and are LV_{day}=69 dBA, LV_{night}=59 dBA for area around Port of Koper (Spes et.al., 1998).

Research on causes of mortality and prevailing diseases

Although in pre-school children respiratory diseases are the most common, accounting for 38% of all pre-school childhood diseases, it is lower than the national average. To 15,7% of illnesses contribute their diseases of the nervous system, while 11,4% illness remains unclassified. The prevalence of respiratory diseases is the highest among school children (22,2%), which is again lower than the national average (33,3%). Otherwise 18,6% of treatments is caused for injuries and poisoning and 14% for infectious and parasitic caused diseases.

Respiratory diseases are also prevalent among the adult population. A general analysis shows, that people in coastal zone visited a dispensary at a rate of 2,9 per 1000 people in 1995 - a figure lower than the national average (4,7 per 1000 people in 1995). The hospitalisation rate

per inhabitant due to injuries for adult people is again much lower than the national average (8,8 – 12,5/1000 compared to 13,9-15,5/1000 people in other areas).

Alternatively, the hospitalisation rate for cancer patients is higher than the national average, which is attributable to the higher proportion of older inhabitants among the coastal population. The incidence of cancer in the area rose from 3,1 /1000 in 1991 to 4,5 /1000 in 1994 and 3,7/1000 in 1995. The most prevalent forms of cancer are lung cancer, breast cancer and skin cancer.

The conclusion of a study into the 'Quality of living environment in the Koper municipality', Institute of geography, 1998 Ljubljana was that environmental pollution does not aggravate the health status of the inhabitancy in the area.

5.2 Ranking of environmental impacts

Ranking of the Ports' environmental impacts was based on the available monitoring data, environmental research made in the area and on expert opinion on the present level of pollution, risk assessment of activities, presence of continuous impacts on the environment, toxicity of substances, bioaccumulation, and the harmful impact on human health and ecosystem due to accidental release.

There are gaps in the monitoring data and gaps in the knowledge, especially about the presence of alien species - therefore numerical classification of impacts according to expert opinion was used. Experts, involved in environmental research in the area were consulted. The points considered herein emphasise the complexity of environmental issues and the difficult task facing respondents when grading the environmental impacts of the port. The recalculation of ranking was performed according to the maximum number of points, so that a direct comparison with the survey results is possible. Grading scale and rankings are presented in *APPENDIX 4*. Table 5.1 shows the ranking scale.

Table 5.1
Ranking of environmental impacts

Severity (S)		Probability for damage to human health or ecosystems occurrence(P)	
Catastrophic impact	4	High (happens often)	4
Medium impact	3	Medium (can happen)	3
Small impact	2	Low (can happen in similar industries)	2
No impact	1	Very low (not likely to happen)	1

5.3 Population sample

In the first part of the survey we chose respondents from locations surrounding of the Port to represent the general population. Two comparison groups are:

- General population - residents in Koper coastal zone older than 18 years;
- People, economically bound to the Port – employees of the Port of Koper.

Since all respondents live in a common social setting (coastal zone), the influence of the environment is similar for everybody. The basic difference between the two groups is the economical dependence on the activity (institutional constraint) and possible extraneous variables, which are identified in the process (gender, age, education, employment).

The group sampled from the general population included people, living in the city of Koper, Ankaran and in the villages Bertoki, Hrvatini, Zgornje Skofije and Spodnje Skofije (Fig. 5.1).

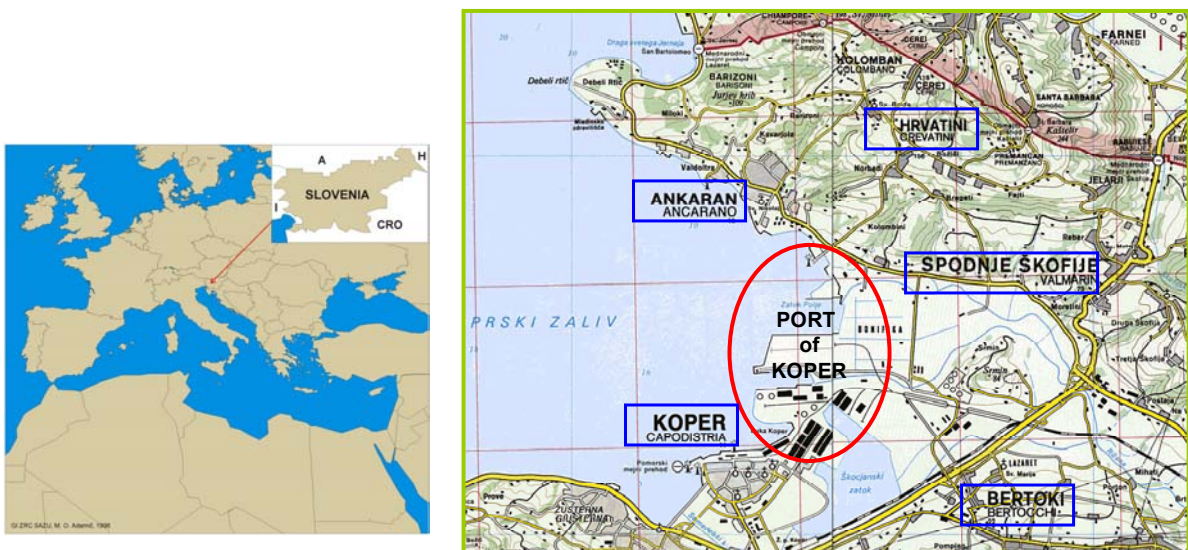

Fig.5.1: Sampling locations

To obtain a clustered random sample of the general population according to location the population was divided into geographic units from which the Statistical Office of the Republic Slovenia (SORS) prepared a random sample. The number of people, chosen in each cluster was dependent on the size of the village/town.

Table 5.2 shows the cumulative number of population in these locations and its' growth after 1869. It is interesting to see that the population in the area shows a negative growth between 1991 and 2003 although the population is growing in Koper municipality (1999: 46 530, 2001: 46 947, 2003: 47 096). This decline in population in the City of Koper and the increasing population growth in the surrounding villages suggests a movement of people out of the city of Koper and settling in the surrounding villages. This shows a trend towards de-urbanization in the area adding to the pressure on the environment and the demand for space.

Table 5.2
Population in sampling settlements

	Population in 1869	Population in 1991	Population in 2000	Population in 2003
Ankaran	426	2.659	2.941	3.026
Bertoki	200	867	884	900
Hrvatini	254	1.008	1.102	1.145
Koper	7.773	24.704	23.595	23.113
Sp. Škofije	315	1.105	1.216	1.216
Zg. Škofije	266	579	720	760
All together	9.234	30.922	30.458	30.160

The second group consists of the Port of Koper employees. Authorities of the Port of Koper gave their permission for this research to go ahead and to allow the inclusion of the EIA report and their employees in the survey. Approximately, 1 000 people are employed in the Port and the sampling frame was the list of all employees in the Port. A random sample of 100 employees was selected, by the employment service in the Port of Koper. The size of randomly selected sample for both groups is :

Koper	280	Sp. Škofije	80
Ankaran	150	Zg. Škofije	50
Hrvatini	80	Port of Koper employees	100
Bertoki	80		

Instrument for measurement - questionnaire

Questionnaire with 14 questions was delivered to sample groups in the first survey in 2001 (*APPENDIX 1*) and questionnaire with the same 14 question and additional 4 questions about the information sources was delivered to the same sample groups in the second survey in 2003 (*APPENDIX 2*).

In *Chapter 4* the relation between questions from the questionnaire and dependent variables is shown. Internal consistency of the questionnaire is calculated according to Cronbach's *alpha coefficient*. Calculation example for small sample of 10 questionnaires is in *APPENDIX 5*. Index, calculated in example has the value 0,83. This is acceptable according to literature, which suggests that Chronbach's coefficient shows a lower correlation than it actually is and that an index, higher than 0,60 is acceptable for evaluation of the questionnaires (*Black, 1999*).

5.4 Pilot study

The pilot study was performed to check, if the statements in the questionnaire and accompanying letter are clear and understandable. The pilot was performed on a small sample (50) from the city of Koper. The response was 46% (without any reminders) and among the returned questionnaires, only two were invalid - people did not properly understand the explanation on the ranking of questions. Because people from the Phone book were selected, the sample was not representative and not included in later analysis of the study, however according to the observations made from the pilot study some improvements to the actual questionnaire were made.

5.5 First survey

In the first survey (spring of 2001), 820 questionnaires with accompanying letter were sent out to people from randomly selected samples. The response rate was 40% although some of the questionnaires were not completed correctly and were excluded from the analysis. The number of valid questionnaires was 292.

Beside filled questionnaires, also some comments on the questionnaire and letters from people, concerned about environmental issues in their surrounding were received. Some of them were connected to the Port of Koper, others were more general, concerning environmental problems in other parts of coastal region. Beside kind letters, there were also some threats and comments from people, who would like to see the Port of Koper closed and from employees of the Port, who considered the research as an attack on the Port.

5.6 Presentation of EIA report data for Port of Koper

Planned presentations

Pier III

The original research plan included a presentation of the Port's environmental impact assessment for the construction of Pear III for the Container terminal that was to be built in the north part of the Port (*Pier III* area on the Fig. 5.2). The environmental impact statement (EIS) for the EIA process was already prepared when the Port decided to cease with construction. The reason for not continuing with Pier III was due to a disagreement with the government about concession contract conditions. These kinds of difficulties are connected to transitional problems of the country. The privatisation process at that time was ongoing (autumn 2001) and issues still remain unsolved in 2005. Also, since September 2004 the residents of Ankaran (A on the Fig. 5.2) have kept up a major campaign against the construction of the Pier III. The

residents claim that the Port did not comply with environmental standards in the past and are concerned about the possible noise and light emissions from the container terminal on the new pier. Their primary demand from the Port is to reduce dust emissions by removing the coal terminal and building a container terminal instead - and stop the construction of Pier III.

The final decision will probably be political, since the Port of Koper is of strategic national importance and both national and local government support the expansion of the Port. The debate, which included the entire Slovene population, is still ongoing in 2005.

Storage area on the Pier II

The next project in the Port for which an EIA process was obligatory was the building of a new warehouse area for general cargo on Pier II (*WH* in the picture Fig. 5.2). The presentation of EIS took place in Koper in the spring 2002 with only fifteen visitors from Koper attending (*K* on Fig. 5.2). One reason for this was the time setting – Tuesday at noon. Another reason was that the project was neither a hazardous nor a disturbing activity. Public display of the projects and the EIS was exhibited in the Municipality offices for two weeks prior to the presentation.

Information about the presentation was published in the local newspaper - according to environmental law. Since the subject of the presentation generated little public interest, it was not considered sufficiently relevant to have any influence on public opinion.



Fig. 5.2: Disposition of Ankara, Port of Koper and City of Koper

Presentation of EIS for Coal terminal expansion

The third project to be assessed was the reconstruction and expansion of the Coal terminal (*CT* area on Fig. 5.2), which is of concern due to the dust emissions from the open coal piles. The project included new technologies for reloading (closed system) and dust barriers - curtains around the terminal together with additional spatial expansion of technology to the area, which was already used for coal storage without any environmental protection measures. Abatement equipment and spatial arrangement, built in 2004 on the coal terminal is expected to lower dust emissions (Fig. 5.3).



Fig. 5.3: Disposition of the curtain on coal terminal and the new curtain to prevent dust spreading (2004)

The presentation was prepared with visual aids and with relevant plans on display. Representatives of the Port presented their activities, their environmental protection measures and monitoring program for the environmental impact control.

The first presentation in EIA process was in December 2002 in Koper (K on Fig. 5.2) and was organized according to environmental law. The time of the presentation was on a Tuesday at 1pm. Only 18 representatives of the public came to the presentation. Among them were two representatives of the press. The report from the presentation was published in the local paper and broadcast on the radio.

Beside the presentation in Koper another presentation with the same contents was prepared in Ankarán (A on Fig. 5.2) and organized by The Port authorities. This time the presentation was at 6pm on a Thursday. Information about the presentation was in the local paper, on the local information board, TV and local radio. Over 100 people came to the presentation and participated actively in it. From the public's response it was obvious that they knew little about the Port's activities over the last five years. This presentation did have more media coverage and was reported on local TV, on local and national radio and in the local and national newspapers.

Beside the presentations the Port also made available information on the Internet about their activities and organized open door days for the public, where people were guided over through the Port, including all the terminals. Albeit the excursion was organised for groups or individuals few individuals from the public used this opportunity to familiarise themselves with the ports' activities. Open door days were interesting mainly for local NGO representatives or for organised groups from schools or different organisations.

General environmental impacts of ports

Adverse environmental impacts under normal operation encountered in ports are emissions of noise, odours, air pollution by volatile organic compounds, marine pollution by oil, chemicals, hull paint and other hazardous materials.

Possible sources of emissions from the port activities:

- air pollution
 - loading and unloading of goods (combustion products, VOC)
 - vehicle traffic(combustion products)
 - railway traffic (combustion products)
 - dust spreading during the handling of different cargoes.
- marine pollution
 - operations on terminals
 - accidental discharges of oil, losses from tankers and pipelines,
 - storm water runoff from port parking lots (organic compounds, fine particulates, heavy metals)
 - water thermal pollution,

- soil pollution dredging and excavation of port areas, maintenance of vessels operations on terminals, accidental discharges of oil in the soil, loss from tankers and pipelines,
 - waste generation spill from bulk handling devices, oil terminals and fuel deposits (oily and toxic sludge) maintenance of vessels and port machinery
 - noise generation passenger cars and heavy traffic, loading and unloading activities (quay-cranes, pups, ..) rail traffic noise
 - biological introduction (alien species) timber terminal vegetable, fruit terminal
- Possible pollution sources from ships:
- air pollution ships movement in port ships activities – lighting, heating, refrigeration, ventilation...) tanker loading and unloading liquid bulk ships – cargo pumps for tanker unloading/loading pumps of pumping of ballast water
 - marine pollution bilge water oil from ship-motor leaking, accidental leaking of oil or chemical substances during unloading leaching of paints (particularly containing organotin tributyltin) used for ship bottom coating in order to prevent attachment of algae and molluscs, transfer of harmful aquatic organisms (dinoflagellates, pathogens) with ballast water
 - alien species introduction ballast water attachment of algae and molluscs on the ships' hull
 - waste production wastewater litter detergents
 - noise generation propulsion machinery, auxiliary engines, propeller and transverse propulsion unit, heating, ventilation and air condition system;

Environmental impact of accidents:

- oil spills
- spills of other hazardous material handled in the port
- traffic accidents
- fire on some of the terminals
- explosion of explosive materials handled in the area

Port of Koper environmental impact

Air pollution

Environmental measurements reveal that particulate emissions from the Port have not exceeded statutory emission limits (LV=350_{1month} mg/m².day) since 1999 and particulate concentrations at the Ports perimeter are 44-212_{1month} mg/m². Measurements of inhalable particles emissions were not performed at the time. Emissions of gasses from heating devices and other atmospheric emissions are within the statutory emission limits, although the influence of traffic on air quality due to the Port's activities is substantial (*IOS, 1998 – 2001*).

Marine pollution

Marine pollution under normal operation is minimized by outflow water collection and wastewater treatment. The Port has increased the cleaning of surfaces and begun collection and storage of precipitation water for coal pile spraying.

Measurements show that the concentration of PAH, which is attributed to marine traffic is not significant in the water column but PAHs are accumulating in sediments and shellfish tissues. Sediment concentrations of both aromatic hydrocarbons (3,9 µg/g) and aliphatic hydrocarbons (15,30 µg/g) in the Port of Koper are higher than in the sediments sampled from the open sea - aromatic hydrocarbons (0,94 – 1,24 µg/g) and aliphatic hydrocarbons (2,72-4,88 µg/g) (*NIB, 1997-2001*).

A potential source of pollution from microorganisms and nutrients is from the live stock terminal, while secondary sources of pollution can arise from particulate emissions from construction works and the traffic, coal and iron ore terminals. Other concerns include possible major pollution incidents caused by shipping accidents (see Accidents in transportation) as well as chronic emissions from shipping traffic, such as fuel residues, detergents, wastewater, waste or litter and the introduction of alien species to the area.

Also of concern is the storage of hazardous materials, especially in case accidental release into the environment. At present, the Port stores substances from groups C, D and Appendix III of the MARPOL list of hazardous substances. Substances from category A and B, which present the highest risk are not stored in the area.

Alien species introduction

Most of the ships in the Port bring the cargo to the port and seldom discard ballast waters in the area. However, alien species introduction is a concern whenever shipping is involved, since ships can harbour organisms in ballast water, sediments, or as result of hull fouling. The problem of living organism's transport in ballast water is addressed by the MARPOL convention that requires ships to exchange ballast water far out to sea, however the measures to control the introduction of foreign species are difficult to control. To date 35 introduced species were recorded (26 animals and 9 algae) in the Northern Adriatic Sea (*Orlando Bonaca, 2001*). Their impact on the ecosystem is unknown (*REP, 2003*).

There were also cases of animal species coming ashore hidden in fruit and vegetables cargo, but no research was performed on the issue.

Soil pollution

Soil pollution is not a concern, since the Port is built on reclaimed land covered with water-resistant materials (asphalt, concrete) over impervious soil. Those areas set aside for the storage of hazardous materials were reconstructed in 1999 according to European standards.

Waste generation

Waste generation in the Port although substantial is typically non-hazardous, except wastewater treatment plants effluents and effluents from settlement basins. The Port's waste is collected separately; organic waste is composted and biologically treated to produce humus, while other waste is either recycled or discarded according to regulations. Hazardous waste is collected by certified institution and mostly incinerated.

Noise

Noise is a concern under normal operation. Twenty-four hour continuous noise measurements show daytime noise levels of 55-65 dBA and night time levels of 48-63 dBA. Most of the noise is from the manipulation of materials (reloading), land and sea traffic and construction. Noise abatement is recommended (*IOS, 1998 – 2001*) and is being executed by purchase of technological equipment with low noise emissions.

Accidents in transportation

Road accidents are not common in the Port of Koper area, but road accidents including trucks from the Port can happen anywhere in Slovenia and the consequences are unknown.

In total 114 hazardous products are transported through Slovenian waters including oil products, liquid and packaged hazardous and noxious substances (HNS) and solid substance (coal). The main risks from shipping according to a study by *Ecolas (2003)* for oil and HNS spills in the Mediterranean Sea are from ships grounding or from collisions. The risk of an accident occurring in Slovenian coastal waters is one in every 24 years for oil transport, one every 31 years for all HNS bulk and one every 40 years for all HNS in packaged form. The total average spill quantity per transport is approximately 177 tons (oil), 1142 tons (HNS bulk) and 9 tons (HNS packaged). Accidents with oil tankers are from bunker transport and are expected at a rate of one every 42 years. The high figure for the HNS bulk is due to the traffic of coal. Coal transportation attributes to a spill accident frequency of one every 34 years with an average spill quantity of 1.218 ton, while an accident with liquid HNS transported in bulk occurs once every 407 years with an average spill quantity of 238 ton. The accident risk rate for the marine pollutants is one every 72 years with an average spill quantity per transport of 5,7 tons.

Rail accidents are uncommon in the area, due mainly to speed limits and control, but rail accidents can happen anywhere in Slovenia. Once again the consequences are unknown and there is at present no contingency plan in place for rail accidents.

5.7 The second survey

A second survey was performed two weeks after the presentation in Ankaran in the spring of 2003. In all 820 questionnaires with accompanying letter were sent out to the same random sample of people. The average response rate was 51% (421 questionnaires returned) but only 383 of these were valid and analysed. The response was better than in first survey with the biggest difference being the number of respondents from Ankaran – it rose from 35% in 1st survey to 62% in 2nd survey, an increase explained by their interest in the Port's actions and by its' popularisation due to EIA process.

6. RESULTS

6.1 Respondents sample parameters

Respondent's sample parameters were checked in order to investigate if the sample was representative of the population. Additional graphs and tables are presented in *APPENDIX 3 (A3)*

Table 6.1
Respondents sample size for each location

	Ankaran	Bertoki	Hrvatini	Koper	Port of Koper	Sp Skofije	Zg Skofije	All together
1 st survey	50	37	25	109	33	16	22	292
2 nd survey	91	26	32	125	41	42	22	383

A comparison of the education structure shows, that the structure of the population and of the sample differs for each location. Respondents with no- and primary education are under-represented and respondents with university education are over-represented in each case. One reason is that people with lower education may have difficulty in filling out a questionnaire of this length and content (*Table A3/7*).

The age structure of the groups to the population structure at pooled locations shows, that the sample is representative of most locations, except in Hrvatini, Zg. and Sp. Skofije. In Hrvatini older people are under-represented. In Sp. and Zg. Skofije, groups of respondents 46-55 are under-represented and number of respondents aged 18-25 are over-represented (*Graph: A 3/1, Table A3/9*).

The gender structure varies at different locations but is similar to the general gender structure of the population as a whole. The difference between both surveys is that the sample group was two years older in the 2nd survey as the same sample was used for both surveys (*Graph: A3/4, Table A3/10*).

A comparison of the employment structure for respondents group to employment structure of the population is similar. Respondents group is structured employed/non-employed = 57,2/11% whereas the population in Koper municipality has the rate employed/non-employed = 42,9/10,1% (*Graph: A 3/4, Table A3/8*).

6.2 Comparison of respondents groups

The main difference between two main groups comprising the general population and employees is in gender structure. The share of female respondents is significantly smaller in the group of employees (male population=88%), which is in accordance with gender structure of the employees in the Port (*Graph A3/4, Table A3/5*). Another difference is that employees of the Port are all employed. These differences in the population structure may influence the results and are therefore controlled in the analysis (*Graph A3/4*).

Education structure of respondents from the group of employees is similar to respondents group from general population in the 1st survey and different in 2nd survey. It is obvious from report on population structure, that mostly different respondents from selected sample filled the questionnaire in the 2nd survey (*Graph A3/4, Table A3/5*).

6.3 Quantitative results

In the analysis 5 (or 4 in some questions) marks the most important source or goal from the questionnaire, 1 is the least important source or goal. The results are quantified for an easier overview and greater transparency. An example of how the results have been calculated for

question Q-4 – trust in sources of information is presented here, and represents part of variable Y1, marked as y_{1-4} , according to equations (1) – (5) (Table 6.2).

Table 6.2
Quantification of results – trust in sources of information

	$y_{(1-4)e}^1$	$y_{(1-4)e}^2$	$y_{(1-4)p}^1$	$y_{(1-4)p}^2$	$\Delta E_{(1-4)}$	$\Delta P_{(1-4)}$	$\Delta ep_{(1-4)}^2$	$\Delta ep_{(1-4)}^1$	$\Delta A_{(1-4)}$
Reporters	2,84	2,60	3,46	3,01	-0,24	-0,44	0,41	0,62	0,20
Port of Koper	4,29	3,46	2,51	2,48	-0,83	-0,03	-0,98	-1,78	-0,80
NGO	2,10	3,33	2,88	3,46	1,24	0,58	0,12	0,78	-0,66
Government	1,65	1,76	1,93	1,79	0,12	-0,14	0,02	0,28	0,02
Experts	4,00	3,84	4,22	4,06	-0,16	-0,16	0,22	0,22	0,00
Sum of grades					0,13	-0,19			-1,24

- $y_{(1-4)e}^1$ - sample mean result for employees (e) in the 1st survey (Graph: y1-4e1)
- $y_{(1-4)e}^2$ - sample mean result for employees (e) in the 2nd survey (Graph: y1-4e2)
- $y_{(1-4)p}^1$ - sample mean result for general population (p) in the 1st survey (Graph: y1-4p1)
- $y_{(1-4)p}^2$ - sample mean result for general population (p) in the 2nd survey (Graph: y1-4p2)
- 1-4 - index, marking partial results for variable Y1, represented by result from the question Q-4
- $\Delta E_{(1-4)}$ - difference between 1st and 2nd survey results for employees (Graph: dE1-4)
- $\Delta P_{(1-4)}$ - difference between 1st and 2nd survey results for general population (Graph: dP1-4)
- $\Delta ep_{(1-4)}^1$ - difference in 1st survey between employees and general population (Graph: d1-4ep1)
- $\Delta ep_{(1-4)}^2$ - difference in 2nd survey between employees and general population (Graph: d1-4ep2)
- $\Delta A_{(1-4)}$ - common difference for both groups in both surveys (Graph: dA1-4)

It is difficult to get the complete picture from tables of individual questions analysis and graphic representation of data can be much more helpful, therefore this study presents the quantified results as shown in Graph 6.1.

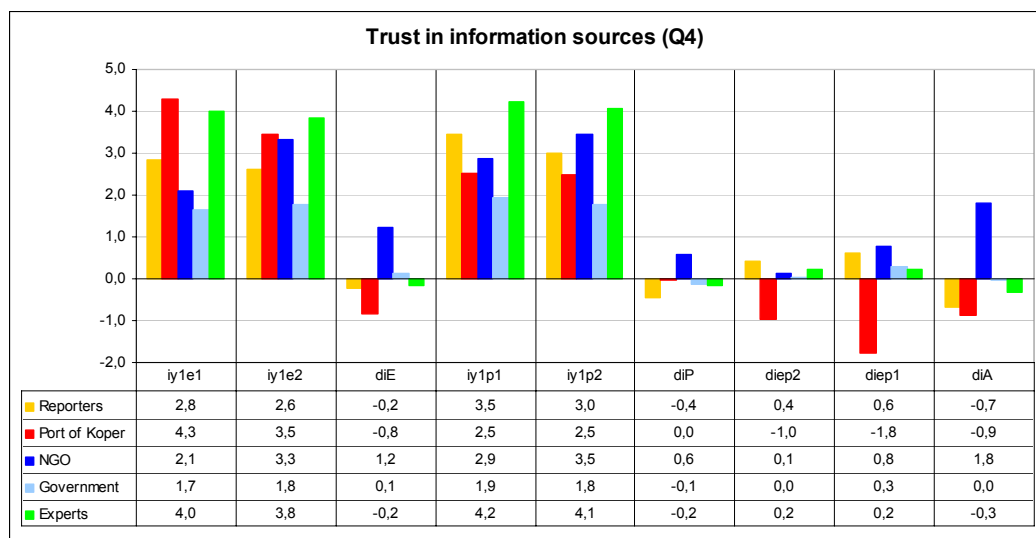

Graph 6.1: Graphic presentation of quantitative results – opinion about trust in information sources

Quantification of the results reveals which differences are the greatest. Graph 6.1 shows that the biggest difference actually occurs in opinion on the Port authority's information and on the NGO information. Substantial differences are identified in the opinion of respondents, employed by the Port; the difference between the first and second survey ($\Delta E_{(1-4)} = y_{(1-4)e}^2 - y_{(1-4)e}^1$) is -0,8 for the Port authorities, which shows that level of trust in the Ports' information fell, whereas a value of +1,2 for NGOs shows that trust in their information rose.

The difference in the opinion of respondents from the general population, between the first and second survey ($\Delta P_{(1-4)} = y_{(1-4)p}^2 - y_{(1-4)p}^1$) is -0,4 for reporters i.e., less trust in their information. In the case of the NGOs the value +0,6 for NGO, indicating an increased level of trust.

Difference identified in opinion between both main groups of respondents in the first survey $\Delta e_{(1-4)p}^1 = y_{(1-4)p}^1 - y_{(1-4)e}^1$ is -1,8 for the level of trust in the Port's information shows that respondents from the general population express a lower level of trust in it than the group of employees do.

Differences, identified in the opinion of respondents in the second survey $\Delta e_{(1-4)p}^2 = y_{(1-4)p}^2 - y_{(1-4)e}^2$ is -1,0 for the trust in the information given by the Port agreeing with the results of the first survey, that general population trusts the information present by the Port less than the Port's employees do.

Cumulative differences between both main groups of respondents in both surveys $\Delta A_{(1-4)} = \Delta P_{(1-4)} - \Delta E_{(1-4)}$ is -0,8 for the trust in Port of Koper information. This shows that change in opinion of group of employees was bigger than that of the general population sample. $\Delta A_{(1-4)}$ for trust in experts and governmental information is 0,0, which is interpreted as the same change in both groups.

Quantification of results supports further investigation, where statistical hypothesis testing identifies, which of these detected differences is statistically significant.

6.4 Hypothesis testing and results qualification

Hypotheses were tested using the statistical methods stated in chapter 4.4 for the following groups:

- main groups:
 - general population (GP)/ employees of the Port (PK)
- controlled for:
 - level of education,
 - gender,
 - age,
 - employment,
 - location of residency.

Variable Y1: environmental information – trust, effectiveness and reliability of information sources used in the EIA process

Public trust in sources of information and reliability of these sources together with preferences for certain modes of information, used in the process are important issues in this research and more questions were dedicated to them. The question about trust in sources of information was included in both surveys to determine any changes occurring with time. In the 2nd survey an additional four questions were added, to deal with the effectiveness of the information sources and respondents preferences for information modes used in the process.

Question Q4 required respondents to rank their trust in information about issues concerning the Port of Koper provided by (newspaper, radio or TV) reporters, Port of Koper authorities, Government, experts with additional options "I trust nobody" and "don't know whom to trust".

Detailed analysis and graphs are presented in APPENDIX 4, Graph A4/1 – 12 and Table A4/1 – 2.

General, *experts* are considered the most trustful source of information in both surveys (mean₁=4,1; mean₂=4,0 on the scale 1-5). The Friedman test shows significant difference in opinions on trust to expert information according to location of residency ($\chi^2=18,541$, sig. = 0,005, df=6). This difference could be attributed to different levels of education on every location since there is a significant correlation in the City of Koper, where respondents with high and medium education and students have a greater level of trust in expert information than respondents with primary or no education (Spearman's $\rho = -0,213$, sig (2-tailed) = 0,039).

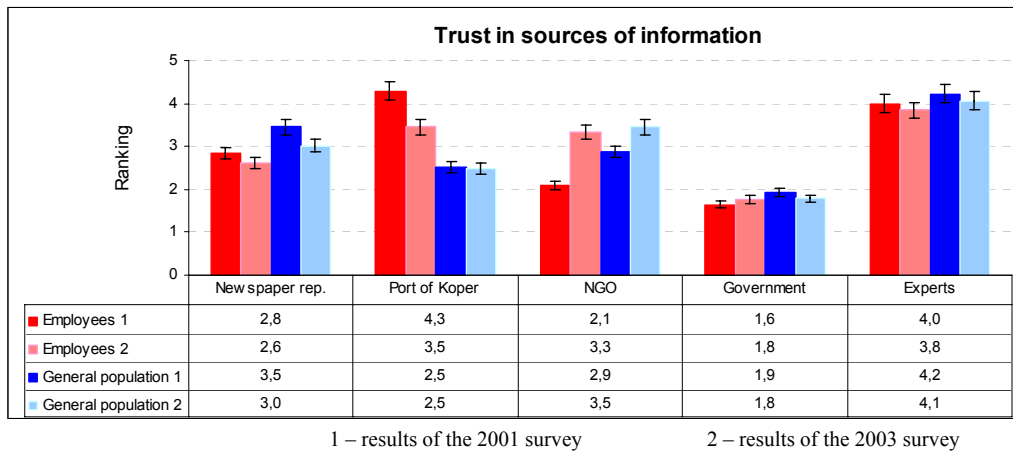

Graph 6.2: Trust to information sources – opinion of employees, general population and experts (mean ranks)

Reporters are considered the second most trusted source of information in the 1st survey (mean=3,4) and the third most trusted in 2nd survey (mean=3,0). This difference is statistically significant, ($z=-3,727$, Asym.Sig. (2-tailed)=0,00) which is comparable to ΔP (=0,44);

The biggest positive change between the two surveys occurs in respondents' trust in NGO information, which is given significantly higher grade in the second survey. NGO's are active and well organized in the coastal zone and participate every time the Port plans new activities in the area.

Significant differences occur in following analyses (Graph 6.1):

- difference in trust to NGO information by employees and general population in the 1st survey ($z=-2,462$, Asym.Sig.(2-tailed)=0,014) which is comparable to Δep^1 (=0,8);
- difference in trust to NGO information by the general population in 1st and 2nd survey ($z=-3,133$, Asym.Sig.(2-tailed)=0,002) which is comparable to ΔP (=0,6);
- difference in trust to NGO information by employees in 1st and 2nd survey ($z=-3,849$, Asym.Sig. (2-tailed)=0,00) which is comparable to ΔE (=1,2).

All other sources of information were graded lower in 2nd survey than in 1st survey. In both surveys the Port of Koper information was fourth (mean₁=2,7, mean₂=2,6) with the least trusted source in both surveys being government information (mean₁=1,9, mean₂=1,8)

An important significant difference occurring in both surveys is trust in *Port of Koper* information, where employees grade it significantly higher than respondents from the general population. Statistical results are:

- trust in the information provided by the Port shown by employees of the Port and the general population in the 1st survey (Wilcoxon Signed Rank Test $z=-3,840$, Asym.Sig.(2-tailed) =0,00 which is comparable to Δep^1 (=-1,8);
- trust in the Port's information by employees of the Port and the general population in 2nd survey ($z=-2,780$, Asym.Sig.(2-tailed)=0,007 which is comparable to Δep^2 (=-1,0);
- trust in Port's information by employees of the Port in the 1st and 2nd survey ($z=-2,723$, Asym.Sig.(2-tailed)=0,006 , which is comparable to ΔA (=-0,8).

Wilcoxon Signed Ranks Test reveal that the respondents level of trust has changed significantly between the surveys for Newspaper reporters by the respondents from the general population and for NGO's by both groups. With the except of the trust in NGO information that rose from mean=2,8 to mean=3,4 overall trust in the remaining sources of information fell. A comparison of both surveys shows that in the first survey 7,5% of respondents answered with "don't know whom to trust" and 7,5% answered with "I trust nobody". In the second survey 11% of respondents "don't know whom to trust" while 5,5% of respondents "trust nobody".

Respondents were asked in question Q-11 to grade which mode of information, organized by the Port of Koper about their activities was the most suitable and effective in informing public: TV news, Internet, newspaper reports, radio broadcasting, 'open door' days in Port of Koper, presentations in EIA process or none of them.

Detailed analysis and graphs are presented in APPENDIX 4, Graph A4/13 – 19 and Table A4/3 – 5.

In all 10,4% of respondents thought that none of the modes of information was either suitable or effective, and 13,1% of respondents "did not know". However, TV news is graded as the most suitable and effective mode (mean=3,6), followed by Newspaper reports (mean=3,4), Radio news (mean=2,9), Public presentations (mean=2,8), and Open door days (mean=2,7). The least effective source according to respondents is the Internet. The employees have a different opinion about the information modes, since they put 'Open door days' in first place (mean=3,8) and Public presentation in EIA process in 2nd place (mean=3,6). Other sources were ranked in the same order as respondents from the general population, starting with TV news in 3rd place (mean=3,0) (Graph 6.3).

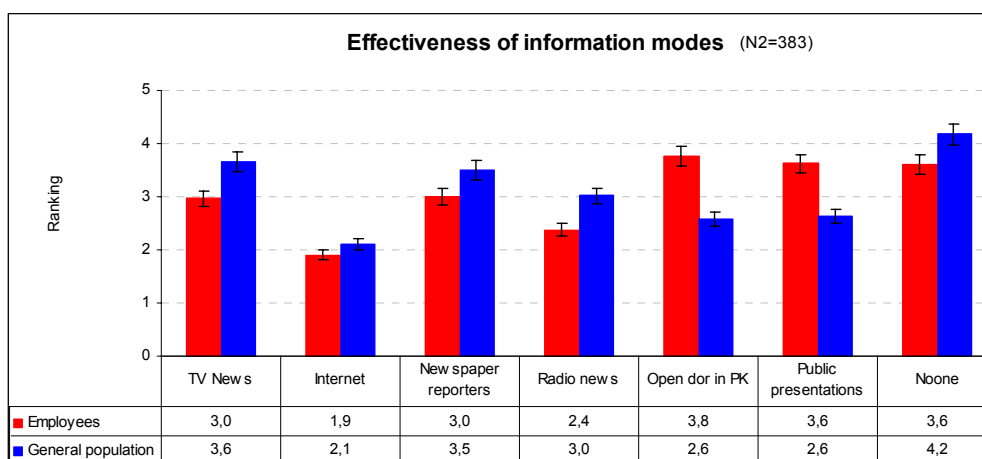

Graph 6.3: Mean results for 'effectiveness of information modes, organized by PK

A correlation occurs in the analysis of Radio news and employment (Spearman' ρ =0,162, N=276, Sig. (2-tailed)=0,012). Employed and unemployed respondents find radio news less effective than retired respondents do. A comparison of education also shows, that respondents with higher education grade radio news lower (mean=3,2) than respondents with a lower education (mean =3,4 – 3,8) and students (mean=4,4). The differences among groups are significant (Kruskal Wallis χ^2 =16,872, N=276, Asymp.Sig.=0,002).

There is also correlation between information provided by Newspaper reporter's and employment, where employed respondents rank it lower (mean=3,3) than unemployed (mean=3,8) and retired respondents do (Spearman' ρ =0,119, N=276, Sig. (2-tailed)=0,049) and education, where respondents with higher education find it less effective (mean=3,2) than respondents with lower education (mean=3,4 – 3,8; students mean=4,42). Differences among groups are significant (Kruskal Wallis χ^2 =16,987, N=276, Asymp.Sig.=0,002).

Another correlation is that which occurs between information provided by 'Open door days' in analysis employment (Spearman' ρ =-0,140, N=276, Sig. (2-tailed)=0,046), where employed respondents find it more important than other groups do.

There is a significant difference between Port employees and the general population in their opinions held on the 'Presentations in EIA process" (Wilcoxon Signed Ranks Test: z=-2,292, Asymp. Sig. (2-tailed) = 0,022) ($\Delta\epsilon p^2$ = -0,98) and about 'Open door days' (Wilcoxon Signed Ranks Test: z=-1,723, Asymp. Sig. (2-tailed) = 0,048).

Big differences occur in the opinions expressed by respondents from different locations, but only certain ones are significant, a reason being that samples from certain locations are insufficient for testing (Graph 6.4). The difference in opinion on the effectiveness of “Open door days” is significantly between respondents from Koper (mean=2,4) and Ankaran (mean=2,9) if we only compare groups in pairs. (Wilcoxon Signed Rank Test: $Z=-2,208$, Asym. Sig. (2-tailed) = 0,027). There is also a significant difference in opinions about the efficiency of open door days in providing information among respondents from City of Koper and employees of the Port (Wilcoxon Signed Rank Test: $Z=-3,151$, Asym. Sig. (2-tailed) = 0,002) and in opinion on Public presentation efficiency (Wilcoxon Signed Rank Test: $Z=-2,001$, Asym. Sig. (2-tailed) = 0,045).

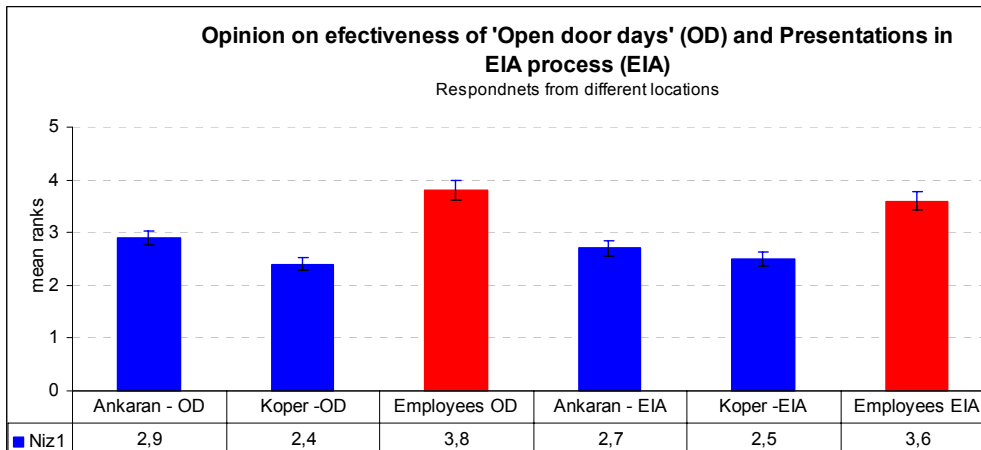

Graph 6.4: Effectiveness of 'Open door days in the Port' and 'Public presentations in EIA process'

Respondents were asked in question Q-14 to grade which source of information was the most effective and reliable in informing the public about issues, connected to the Port's activities and impacts during the last two years: Newspaper and TV reporters, Port of Koper authorities information, NGO, government, experts, rumours, gossip or none of them.

Detailed analysis and graphs are presented in APPENDIX 4, Graph A4/20 – 23 and Table A4/6 – 7.

9,4 % of respondents from the general population thought that *none* of the sources of information is useful. This is opinion mainly of respondents aged 36-55 years old, of both genders, mostly employed and with medium education. Of the respondents from the general population responded 12,3% with 'don't know', while 0,9% of employees think that none of the sources was either effective or reliable and 2,6% of them expressed a “don't know”.

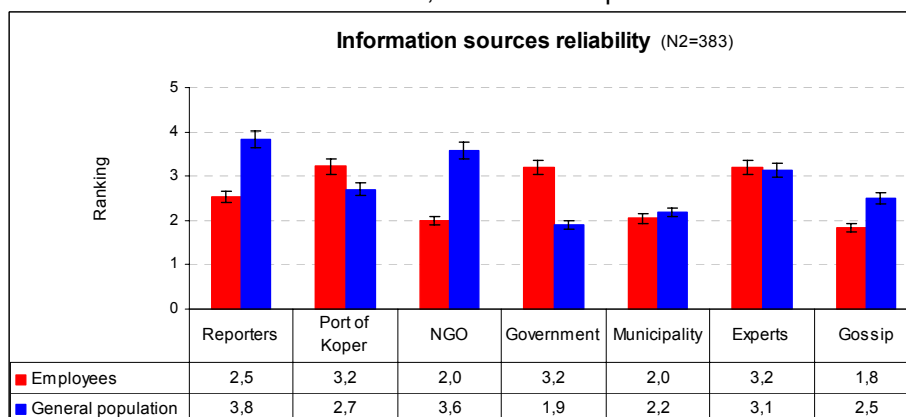

Graph 6.5: Mean results for “reliability of information source about issues, connected to the Ports' activities”

From the stated sources reporters are considered the most reliable and effective source of information (mean=3,8) followed by NGO's (mean=3,5) and experts (mean=3,2). The Port of Koper authorities information (mean=2,9) is considered a bit more helpful than gossip (mean=2,4) while Government is graded as the least helpful source of information (mean=1,9).

There is a significant difference in opinion about *reporters information* among respondents of different gender, where male respondents (mean=3,9) grade its' effectiveness significantly higher than female respondents do (mean=3,6) (Kruskal Wallis $\chi^2=4,905$, $df=1$, Asymp.Sig.=0,027).

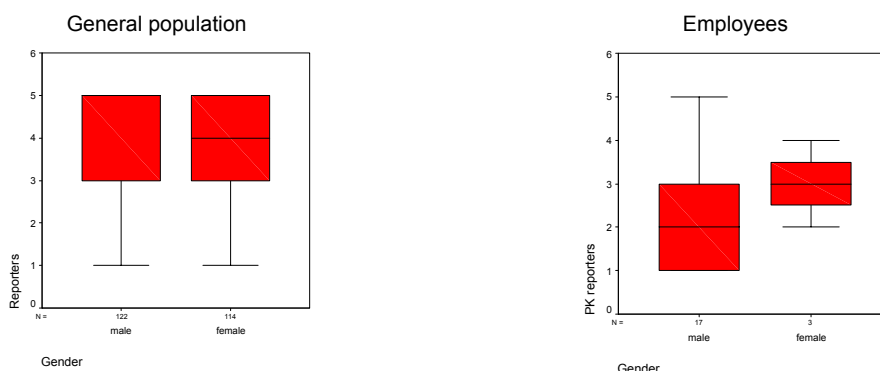

Graph 6.6: Difference between employees and general population / impact of gender – reporters information

Also female respondents in both groups grade reporter's information higher, although respondents of from the general population grade it generally higher than employees (Graph 6.6).

Opinions about the *Port authorities* as a source of information differ among respondents from different locations and employees of the Port. Employees of the Port find it most useful (mean=4,0), followed by residents of Hrvatini (mean=3,9). Respondents from the City of Koper (mean=2,7) (Wilcoxon Signed Rank Test $z=-3,488$, Asymp. Sig. (2-tailed)=0,00), Bertoki (mean=2,1) and Spodnje Škofije (mean=2,2) grade this information significantly lower.

Respondents from different locations grade *NGO* information significantly different when we compare pairs of respondents. Respondents from Bertoki (mean=4,5), Sp. Škofije (mean=3,6) and Ankaran (mean=3,5) give it a grade whereas employees of the Port (mean=3,0) grade it low (Wilcoxon Signed Rank Test $z=-2,209$, Asymp. Sig. (2-tailed)=0,027).

All groups at all locations grade *the government* and the *municipality* as a source of information low.

There is a significant difference in opinion on *expert information* among genders, where female respondents (mean=3,4) grade it as a more effective source of information than male respondents (mean=3,0) (Kruskal Wallis $\chi^2=6,135$, $df=1$, Asymp.Sig.=0,013). There is also a significant difference in opinion about expert information according to education, where respondents with a high education (mean=3,4) and students (mean=3,2) grade it higher than respondents with medium (mean=3,0), primary (mean=2,9) and no education (mean=2,6).

Gossip is graded higher than *governmental* information. Respondents from Hrvatini (mean=3,0) graded it the highest while the employees of the Port (mean=1,8) graded it lowest.

Differences in opinion between employees and the general population are statistically significant only in answers concerning the Port authority's information ($z=-1,98$, Asymp. Sig. (2-tailed)=0,047).

Respondents were asked in question Q-16 to grade which mode of information about changes in environmental quality in coastal zone was the most effective: TV News, Internet, newspaper reporters, Radio news, gossip, NGO, public presentations in EIA process or none of them.

Detailed analysis and graphs are presented in APPENDIX 4, Graph A4/24 – 26 and Table A4/8 – 9.

TV news is considered the most useful and effective source of information (mean=3,9) followed by newspapers (mean=3,4), radio news (mean=2,9), NGO presentations (mean=2,6), public presentations in EIA process (mean=2,6), Internet (mean=2,1) and finally gossip (mean=1,9).

A correlation exists between the level of education and opinion on *public presentation in EIA process*, where respondents with a high education (mean=2,8), grade it higher than respondents with medium education (mean=2,69), primary education (mean=1,9) or students (mean=1,9) (Spearman's $\rho = -1,51$, Sig.(2-tailed)=0,026).

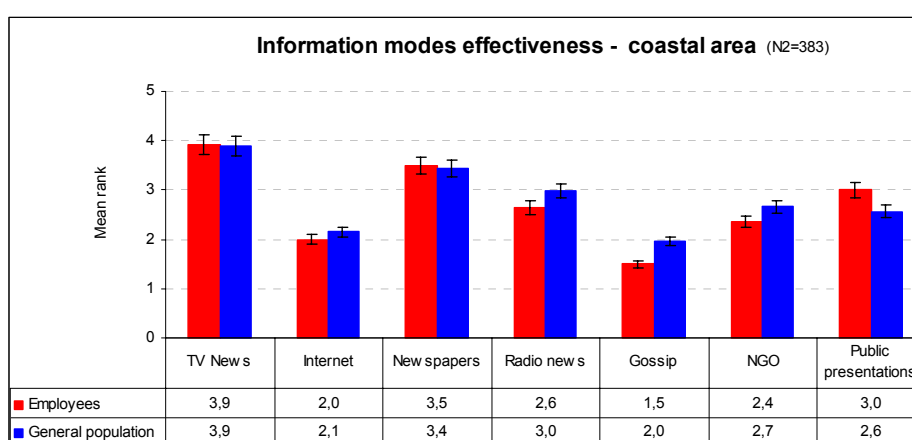

Graph 6.7: Mean results for: 'effectiveness of information sources about changes in environment in coastal zone'

Another significant difference that occurs is in the opinions on *radio news* effectiveness given among respondents of different age, where respondents from 45-65 age group grade radio news higher than the others do (Kruskal Wallis $\chi^2 = 14,16$, $df = 6$, Asymp.Sig.=0,028).

There are some differences in opinion concerning the effectiveness of *NGO presentations, public presentations as part of the EIA process* and *gossip* among respondents from different locations and employees of the Port, but these differences are not statistically significant. Employees of the Port grade the EIA presentations highest of all (mean=3,0).

Respondents were asked in question Q-17 to grade which mode of information was the most effective in informing the public about the Port's environmental impact: TV news, Internet, newspaper reporters, Radio news, gossip, NGO, public presentations in EIA process or none of them.

A more detailed analysis and graphs are presented in APPENDIX 4, Graph A4/27 – 28 and Table A4/10 – 11.

TV news is considered the most effective mode of information from all (mean=3,8). In second place are newspapers (mean=3,5), followed by radio news (mean=2,9), NGO presentations (mean=2,7) and public presentations in EIA process (mean=2,6), gossip (mean = 2,2) and finally the Internet (mean=2,0).

There is a significant difference in opinion among respondents with differing levels of education on public presentations organized by NGO's, where respondents with a high education (mean=2,9), grade it higher than respondents with medium education (mean=2,6), primary

education (mean=2,6) or students (mean=2,6) (Kruskal Wallis $\chi^2=8,170$, df=3, Asymp.Sig.=0,043).

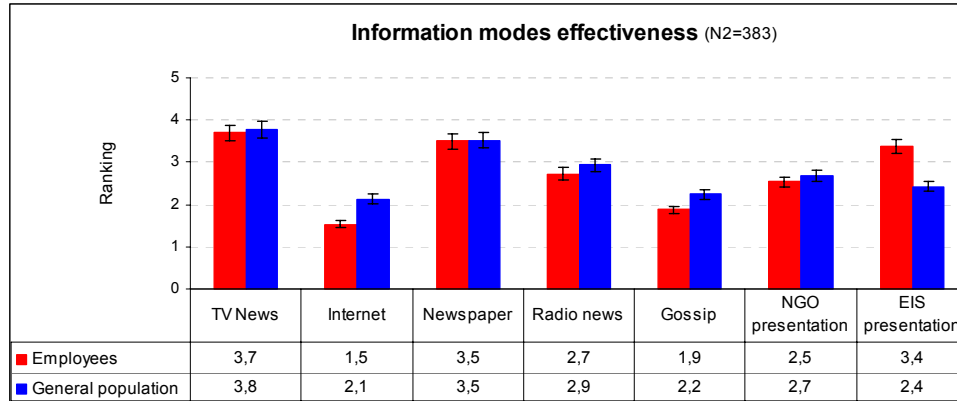

Graph 6.8: Mean results for: 'effectiveness of information about the Ports' impact'

Employees of the Port (mean=3,4) grade the effectiveness of EIA presentations significantly higher than the others do (mean=2,4)(Wilcoxon Signed Ranks $Z=-2,177$, Asymp. Sig. (2-tailed)=0,021).

Overview of results on environmental information

Table 6.3 shows overview of all questions about information sources with marks about the influence of gender (G), education (E), age (A), employment (Em), location (L), time (T) and differences between general population and employees (G/E). Significant differences are marked with grey fields.

Table 6.3
Significant differences in trust into information sources, opinion about sources reliability and modes of information effectiveness

Sources and modes of information	G	E	A	Em	L	T	G/E
Trust in sources of environmental information – general about PK							
Effectiveness of info modes – general PK information							
Reliability of sources - PK environmental impacts							
Effectiveness of info modes – coast environmental quality							
Effectiveness of info modes – PK environmental impacts							

G – gender
 E – education
 L – location
 T – time
 A – age
 Em – employment
 G/E – general population / employees

 - significant impact of variable on results

Variable Y2: priorities in the Port of Koper development

Respondents were asked in question Q-5 to mark the most important issue for the development of the Port of Koper:

- 1 - safety in transportation and processing
- 2 – jobs opportunities
- 3 – no disturbance of nearby Ankaran
- 4 – pollution prevention

Question about concern for no disturbance of Ankaran was added, because respondents from Ankaran continually complain about activities of the Port. Some respondents believe that the area around the Port of Koper should be for tourism and as such connected to the Ankaran tourist area. Only respondents from Ankaran express concern about the disturbance of Ankaran, as expected.

Results of both surveys show that concern for pollution prevention is considered the most important issue, even more than concern for safety in transportation and processing. Both issues are interconnected and it was probably difficult to decide which one to choose. It concerns also an understanding that good technological and safety process are conditional for pollution prevention, but have to be 'upgraded' by the proper use and regular maintenance.

Cross tabulation shows that male respondents are more concerned for safety in the port whether female respondents are more concerned about environmental protection in general than male respondents. The highest concern for environmental protection display respondents from Bertoki. Respondents from City of Koper and Bertoki show the highest interest in employment opportunities in the Port.

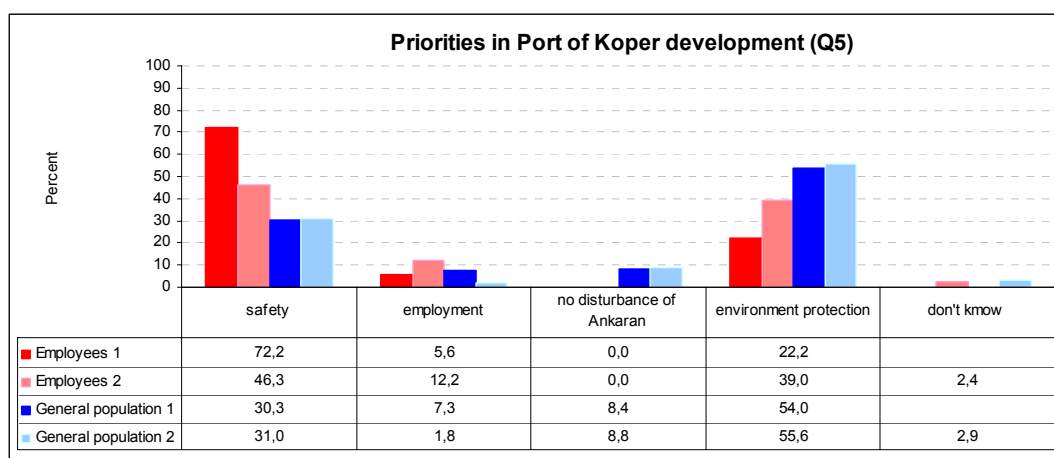

Graph 6.9: Priorities in Port of Koper development (percentage table)

A significant difference occurs in when comparing employees to the general population in that employees show concern mostly for safety and less for environmental protection. Respondents from the general population on the other hand are concerned mainly about environmental protection in the Port.

Variable Y3: value structure on which society currently depends

Respondents were asked in question Q6 to rank the following goals according to level of importance for Slovenia: clean and healthy environment, solid economy, economic growth, humane society, and freedom of speech on the scale 1-5.

Detailed analysis and graphs are presented in APPENDIX 4, Graph A4/32 – 34 and Table A4/14 – 19.

Cumulative analysis of all groups shows, that respondents regard a stable economy as the most desirable goal in society (mean=3,9). Next comes a clean and healthy environment (mean=3,6), economic growth (mean=3,1) with humane society graded much lower (mean=2,7). The least important goal is freedom of speech (mean = 1,8). A Friedman test shows, that respondents grade stated the values significantly different ($\chi^2=289,789$, $df=4$, Asymp. Sig. =0,00) (Graph 6.10).

A Correlation is identified in the analysis between age and opinions on the importance of a *clean and healthy environment*; older respondents (age 66-75 mean=4,9) rank it this statement higher than younger respondents do (age 18-25, mean=3,3 and age 26-35 mean=3,0). (Spearman's $\rho=0,112$, Sig. (2-tailed)=0,036). There is a statistically significant difference in the opinions of respondents with different levels of education (Kruskal Wallis $\chi^2=27,608$, $df=5$, Asymp. Sig. =0,00) so that those with a primary education grade the importance of this statement the highest (mean = 4,1), whereas those with a high education grade it lower (mean=3,3) and students grade it even lower than that (mean=2,6).

There is a correlation between employment status and opinions express on *economic growth* (Spearman's $\rho =-0,149$, sig (2-tailed) = 0,14, $n=270$), where retired respondents consider economic growth much less important than others, and students consider economic growth more important then other groups.

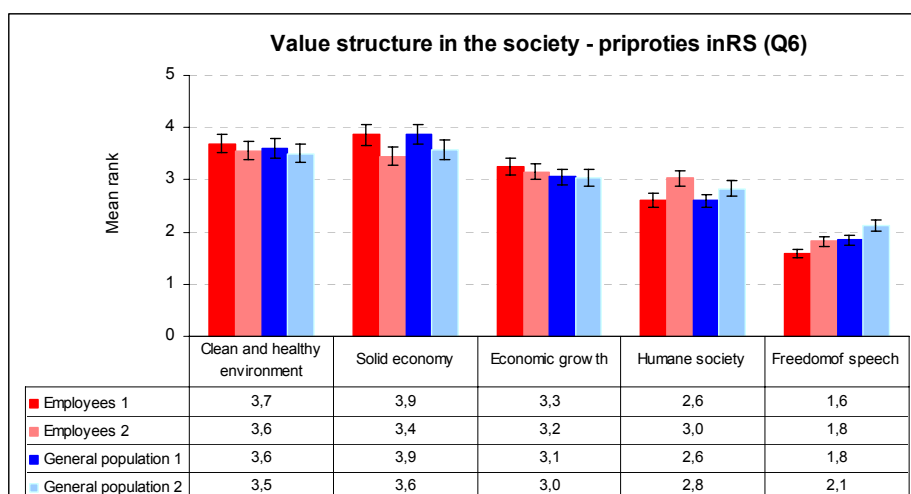

Graph 6.10: Value structure in society

The necessity for a *humane society* did not grade highly (mean=2,7). Differences in opinions occur among respondents of differing age (Kruskal Wallis $\chi^2=19,370$, $df=6$, Asymp. Sig. 0,004); It appears that older respondents are more concerned about having an humane society than younger respondents.

The Importance of *freedom of speech* was also grade low (the lowest) (mean=1,8). The main difference in opinion occurs among respondents of different age (Kruskal Wallis $\chi^2=17,545$, $df=6$, Asymp. Sig. 0,007)

Results from the second survey are similar to the first one, but we can see a reduction in concern for the environment, a stable economy and economic growth while there is an increase in the desire for a humane society and freedom of speech. The differences between the two surveys are significant for a stable economy (Wilcoxon $z=-2,308$, Asym.Sig.=0,021) ($\Delta P=-0,29$, $\Delta E=-0,41$) and for freedom of speech (Wilcoxon $z=-2,109$, Asym.Sig.=0,035) ($\Delta P=0,27$, $\Delta E=0,31$). There are no significant differences between opinions of general population and employees. The main influence of the respondent's group's age structure is identified.

Table 6.4 gives an overview of the questions concerning information sources and the significant influence of gender (G), education (E), age (A), employment (Em), location (L), time (T) and the differences between the general population and employees (G/E). Significant differences are marked with grey fields.

Table 6.4
Significant differences – value structure on which society currently depends

Societal goals	G	E	A	Em	L	T	G/E
Solid economy							
Clean and healthy environment							
Economic growth							
Humane society							
Freedom of speech							

G – gender E – education A – age Em – employment
L – location T – time G/E – general population / employees

- significant impact of extraneous variable on results

Variable Y4: readiness of society to risk material safety in order to protect the environment

Respondents were asked in question Q7 to rank on the scale 1-4 their agreement with the statement: 'Environment has to be protected even if it means less jobs in local community'

More detailed analysis and graphs are presented in APPENDIX 4, Graph A4/35 and Table A4/20 – 24.

The mean rank of results was 3,0 (on the scale 1-4) in the 1st survey and 3,1 in 2nd survey. The influence of employment shows an expected pattern, with students agreeing least with Q7 (mean=2,4) i.e., more concern for jobs, while retirees show the highest agreement with the statement. According to Kruskal Wallis test the influence of employment status is statistically significant. ($\chi^2=10,49$, $df=3$, Asymp. Sig. =0,015). Analysis of respondents according to their age indicates that the lowest agreement with the statement is among younger respondents (18-25 years, mean=2,8 and the highest in group 66-75 years, mean=3,2). Correlation among the level of agreement and age is significant (Spearman's $\rho = -1,06$, sig (2-tailed)=0,039).

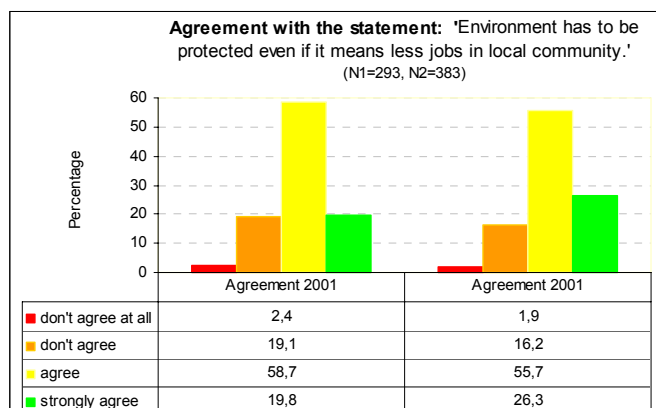

Graph 6.11: Percentage table – Agreement with the statement

There is a significant difference between employees and the general population (Wilcoxon $z=-2,559$, Asym.Sig.(2-tailed)=0,01), where the general population agrees more strongly with the statement than employees. The answers show a picture of respondents, who have relatively a high environmental conscience and are ready to protect environment even if it means less jobs in local community.

Variable Y5: perception of environmental issues in coastal zone

Air pollution

Respondents were asked in question **Q-8** to rank the most important sources of **air pollution** in the coastal zone on a scale 1-5. They had following choices: agriculture, waste and waste sites, industry, tourism, Port of Koper, road traffic, individual fire places.

Detailed analysis and graphs are presented in *APPENDIX 4, Graph A4/36 – 41 and Table A4/25 – 30.*

Respondents graded Industry as the most important contributor to air pollution (mean = 4,0), the second source is Waste and waste treatment with the mean=3,3. The third most important source is considered to be road traffic (mean=3,1), than Port of Koper (mean =2,8) and Tourism (mean=2,2). The least important source of air pollution would be agriculture (mean = 1,8).

A correlation occurs in between questions about:

- the impact of waste treatment and waste sites on air pollution and gender (Spearman's $\rho=0,164$, sig (2-tailed) = 0,01, $n=248$), where female respondents grade this impact significantly lower (mean=3,1) than male respondents do (mean=3,5) and
- the impact of Port of Koper on air pollution and gender (Spearman's $\rho=0,195$, sig (2-tailed) = 0,002, $n=248$), where female respondents grade this impact significantly higher (mean=3,1) than male respondents (mean=2,6).

In terms of pollution there are only a few differences between the surveys. Respondents from the general population grade both the waste sites and waste treatment's influence on air pollution lower in second survey (Wilcoxon $z=-2,707$, Asymp.Sig. (2-tailed)=0,007) ($\Delta P=-0,30$) and the influence of Port's activity higher in second survey than in the first one (Wilcoxon $z=-4,80$, Asymp.Sig. (2-tailed)=0,00) ($\Delta P=0,42$). There is also a difference in the response by respondents from Ankaran and Koper. Respondents from Ankaran grade the Port's impact on air quality significantly higher (mean=3,8) than in the first survey (mean=3,2) (Friedman $\chi^2=8,76$, $df=1$, Asymp.Sig. = 0,003). This difference can be assigned to popularisation of the Port of Koper issues (Graph 6.12).

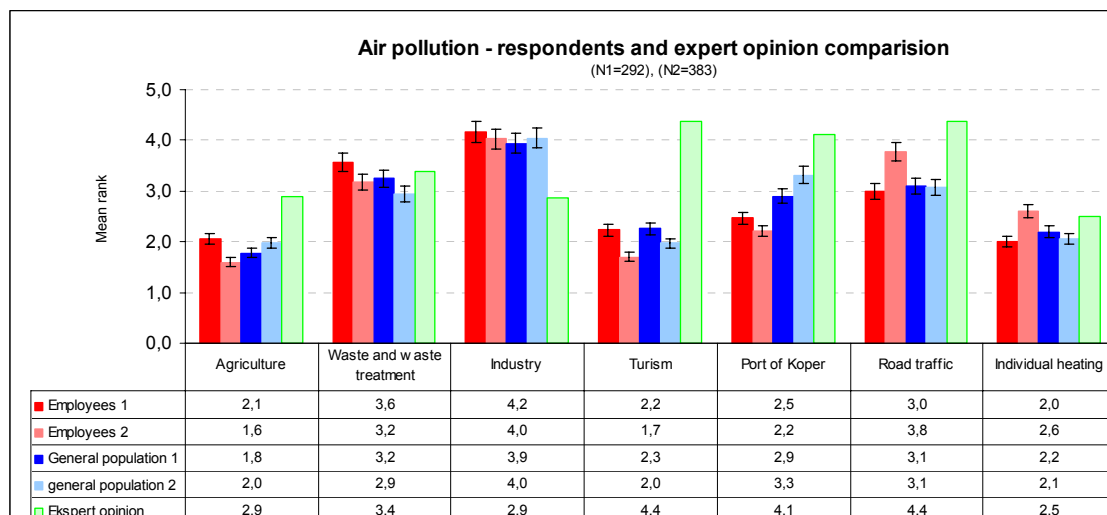

Graph 6.12: Air pollution source – comparison survey results to expert data

Changes over time in opinions and differences among groups are presented on Graph 6.13.

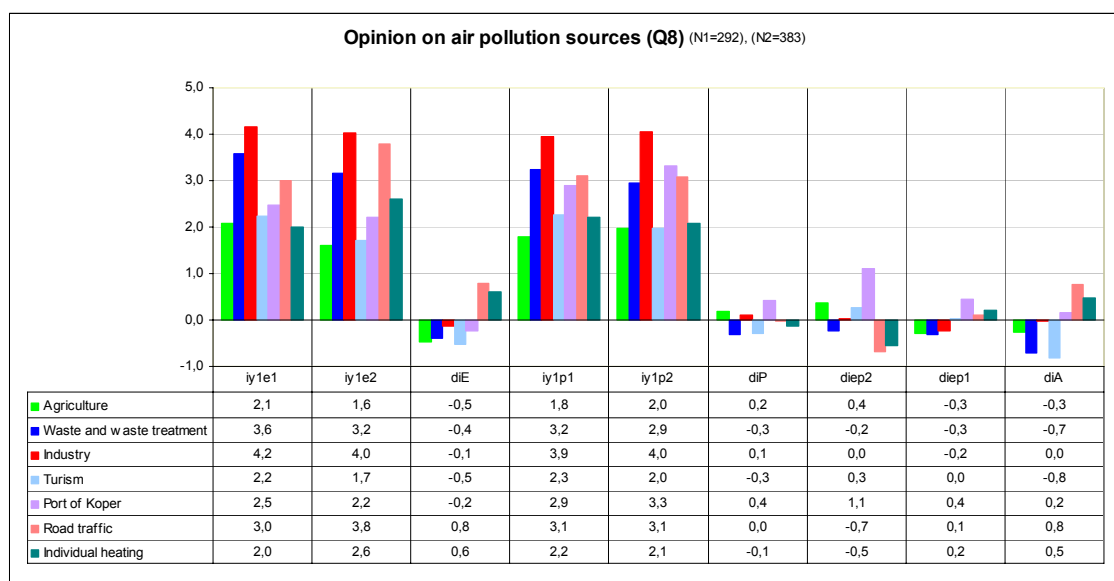

- $Y_{(5-8)e}^1$ - sample mean result for employees (e) in the 1st survey (Graph: y5-8e1)
- $Y_{(5-8)e}^2$ - sample mean result for employees (e) in the 2nd survey (Graph: y5-8e2)
- $Y_{(5-8)p}^1$ - sample mean result for general population (p) in the 1st survey (Graph: y5-8p1)
- $Y_{(5-8)p}^2$ - sample mean result for general population (p) in the 2nd survey (Graph: y5-8p2)
- 5-8 - index, marking partial results for variable Y5, represented by result from the question Q-8
- $\Delta E_{(5-8)}$ - difference between 1st and 2nd survey results for employees (Graph: dE5-8)
- $\Delta P_{(5-8)}$ - difference between 1st and 2nd survey results for general population (Graph: dP5-8)
- $\Delta ep_{(5-8)}^1$ - difference in 1st survey between employees and general population (Graph: d5-8ep1)
- $\Delta ep_{(5-8)}^2$ - difference in 2nd survey between employees and general population (Graph: d5-8ep2)
- $\Delta A_{(5-8)}$ - common difference for both groups in both surveys (Graph: dA5-8)

Graph 6.13: Opinion o air pollution sources

Marine pollution

Respondents were asked in question Q-9 to rank on the scale 1-5 the most important sources of marine pollution in the coastal zone.

More detailed analysis and graphs are presented in APPENDIX 4, Graph A4/42 – 4.50 and Table A4/31.

Cumulative results of both surveys reveal how respondents grade illegal outflows of wastewater as the most important source of marine pollution (mean = 4,1). This is followed by release of wastewater treatment plants (mean=3,3) and the Port's activity (mean=3,0). Outflow of wastewater from industrial sources (mean=2,9) is the fourth most important source and sea traffic (mean=2,4), road traffic (mean=2,3), tourism (mean=2,3) and finally agriculture (mean=2,0).

There is a correlation between the importance of agriculture and employment status (Spearman's $\rho = -0,221$, sig (2-tailed)=0,038). Employed respondents rate influence of agriculture higher (mean=2,2) than unemployed, retired respondents or students (mean=1,8)

Another correlation occurs between the impact of wastewater release and gender with males grading the illegal outflow higher (mean =4,2) than females (mean = 3,9). (Spearman's $\rho = -0,140$, sig (2-tailed)=0,024). The Kruskal Wallis test shows that this difference in genders is significant (Kruskal Wallis $\chi^2=5,09$, df=1, Asymp. Sig. =0,024).

Graph 6.14 shows a comparison of the survey results to the expert rankings for the impacts on marine quality. It is possible to see a big influence of location, which showing that respondents from different locations grade sources differently.

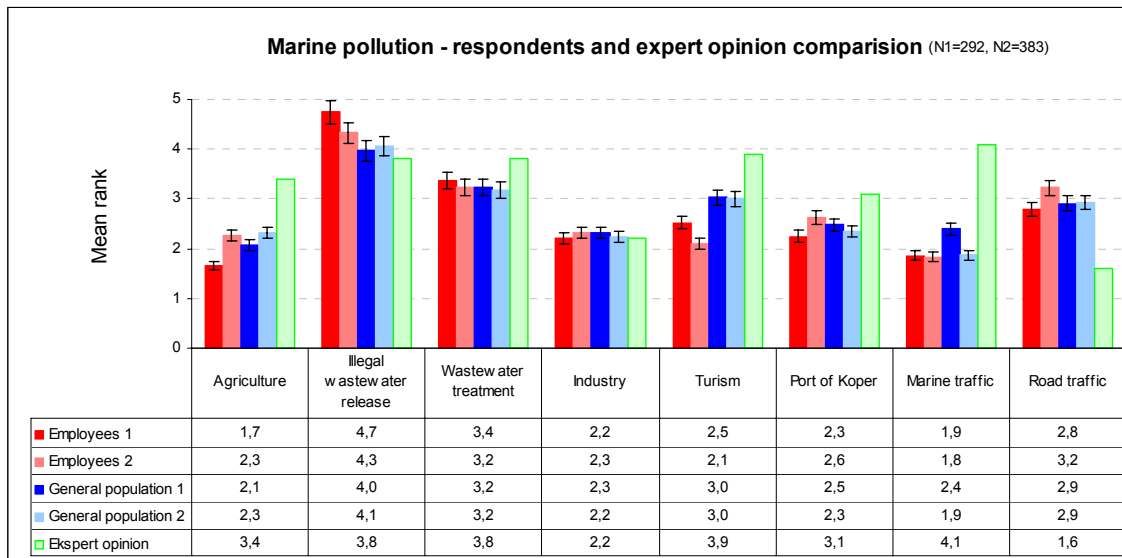

Graph 6.14: Marine pollution sources – Comparison of survey results to expert data

There is also a correlation between opinions about the impact of the Port on marine quality with gender, where males rate the influence of the Port lower (mean=2,8) than females (mean=3,2) (Spearman's $\rho = 0,155$, sig (2-tailed)=0,019) (Graph 6.14).

Changes over time in opinions and differences among groups are presented on Graph 6.15.

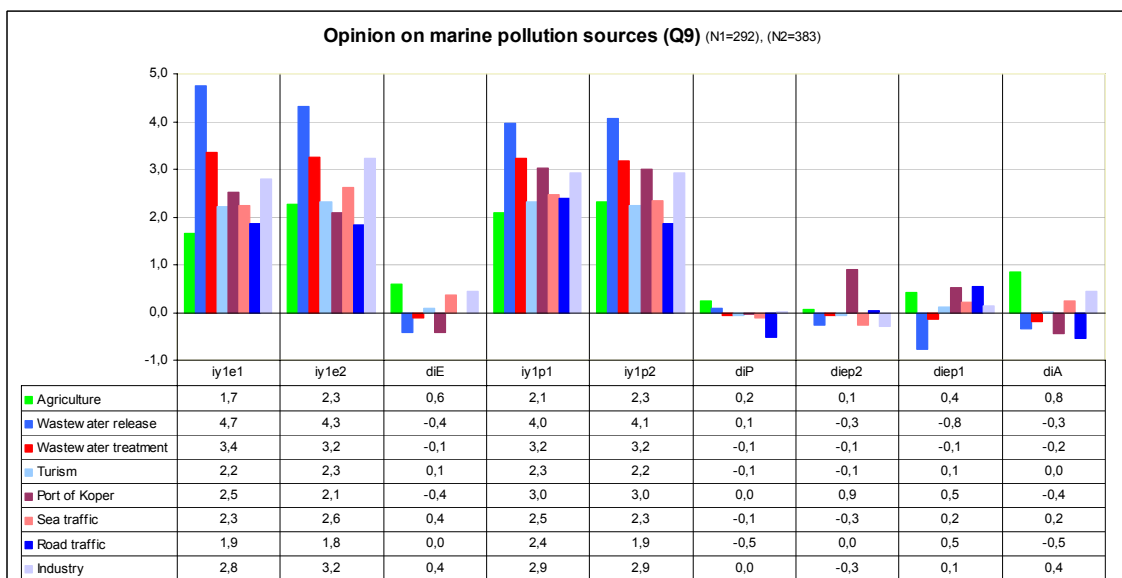

- $Y_{(5-9)e}^1$ - sample mean result for employees (e) in the 1st survey (Graph: y5-9e1)
- $Y_{(5-9)e}^2$ - sample mean result for employees (e) in the 2nd survey (Graph: y5-9e2)
- $Y_{(5-9)p}^1$ - sample mean result for general population (p) in the 1st survey (Graph: y5-9p1)
- $Y_{(5-9)p}^2$ - sample mean result for general population (p) in the 2nd survey (Graph: y5-9p2)
- 5-9 - index, marking partial results for variable Y5, from the question Q-9
- $\Delta E_{(5-9)}$ - difference between 1st and 2nd survey results for employees (Graph: dE5-9)
- $\Delta P_{(5-9)}$ - difference between 1st and 2nd survey results for general population (Graph: dP5-9)
- $\Delta ep_{(5-9)}^1$ - difference in 1st survey between employees and general population (Graph: d5-9ep1)
- $\Delta ep_{(5-9)}^2$ - difference in 2nd survey between employees and general population (Graph: d5-9ep2)
- $\Delta A_{(5-9)}$ - common difference for both groups in both surveys (Graph: dA5-9)

Graph 6.15: Opinion about marine pollution sources

There is also a significant difference between both groups in both surveys on opinion about the Port's impacts, where respondents from the general population grade it significantly higher than the employees of the port do ($z=-2,957$, Asymp. Sig. (2-tailed)=0,003) ($\Delta\epsilon^1=0,52$, $\Delta\epsilon^2=0,90$). The results of the second survey are similar to the first one.

Noise generation

Respondents were asked in question Q-10 to rank the most important sources of noise generation in the coastal zone on the scale 1-5.

A more detailed analysis and graphs are presented in APPENDIX 4, Graph A4/42 – 44 and Table A4/31.

The results of both surveys are similar. The most important source of noise is road traffic (mean=4,5) then the noise emitted by the Port, which is graded much lower (mean=3,2), This is followed by Industry (mean =3,1), tourism (mean =2,5) and finally agriculture (mean=1,7). (Table 6.19)

A comparison of the different groups reveals a correlation between on the influence of road traffic with employment status (Speaeman's $\rho=0,148$, sig (2-tailed)=0,022). Analysis shows that students together with retired respondents' grade the noise from road traffic higher than employed and unemployed respondents do.

More differences occur between respondents with from different locations. Respondents from Bertoki grade the impact of *tourism* on noise levels lower than Respondents from Zg. Skofije (Wilcoxon Signed Rank Test $z=-2,43$, Asymp. Sig. (2.tailed) = 0,015), Koper (Wilcoxon Signed Rank Test $z=-2,142$, Asymp. Sig. (2.tailed) = 0,032), or employees of the Port of Koper ($z=-2,581$, Asymp. Sig. (2.tailed) = 0,01). (Table 6.19)

Respondents from Ankaran grade the impact of *industry* on noise pollution lower than other respondents. Significant difference do occurs among respondents from Ankaran and Koper ($z=-2,178$, Asymp. sig. = 0,029) and the employees of the Port ($z=-1,617$, Asymp. sig. = 0,048). Respondents from Zg. Skofije grade industry higher than other respondents. Difference is significant. (Table 6.2; Appendix 5)

The Impact of *agriculture* is also graded differently. Respondents from the city of Koper and the Port grade the impact of agriculture on noise generation lower than respondents from other locations, although the difference is only significant among the opinions of the residents of Koper and Ankaran (mean=2,3, $z=-2,224$, Asymp. sig. = 0,026). (Table 6.2; Appendix 5)

Respondents from Ankaran grade the impact of *road traffic* significantly lower than respondents from other locations: Bertoki (Wilcoxon Signed Rank Test $z=-2,514$, Asymp. Sig. (2.tailed) = 0,012), Port of Koper (Asymp. Sig. (2.tailed) = 0,000), Hrvatini ($z=-2,543$, Asymp. Sig. (2.tailed) =0,011) and City of Koper ($z=-3,684$, Asymp. Sig. (2.tailed) =0,000). (Table 6.2; Appendix 5)

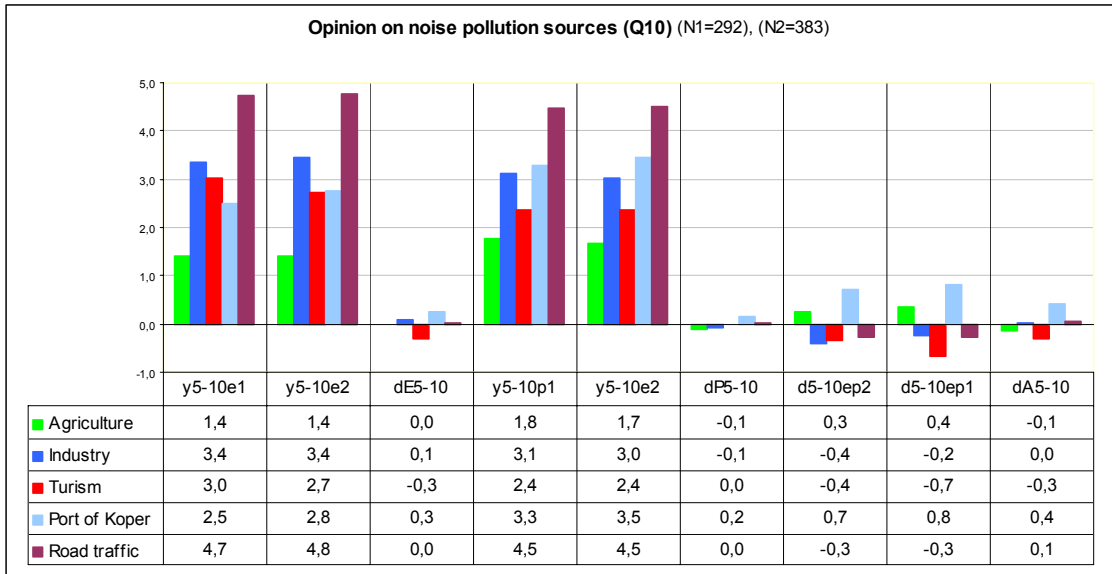

- $y_{(5-10)e_2}^1$ - sample mean result for employees (e) in the 1st survey (Graph: y5-10e1)
- $y_{(5-10)e_2}^2$ - sample mean result for employees (e) in the 2nd survey (Graph: y5-10e2)
- $y_{(5-10)p_1}^1$ - sample mean result for general population (p) in the 1st survey (Graph: y5-10p1)
- $y_{(5-10)p_2}^2$ - sample mean result for general population (p) in the 2nd survey (Graph: y5-10p2)
- 5-10 - index, marking partial results for variable Y5, represented by result from the question Q-8
- $\Delta E_{(5-10)}$ - difference between 1st and 2nd survey results for employees (Graph: dE5-10)
- $\Delta P_{(5-10)}$ - difference between 1st and 2nd survey results for general population (Graph: dP5-10)
- $\Delta ep_{(5-10)}^1$ - difference in 1st survey between employees and general population (Graph: d5-10ep1)
- $\Delta ep_{(5-10)}^2$ - difference in 2nd survey between employees and general population (Graph: d5-10ep2)
- $\Delta A_{(5-10)}$ - common difference for both groups in both surveys (Graph: dA5-10)

Graph 6.16: Opinion about noise pollution sources

Concerning noise pollution there are differences in opinions between employees and respondents from the general population, where employee's grade road traffic and industry significantly higher than the general population (Wilcoxon Signed Rank Test $z=-2,488$, Asymp.Sig.(2-tailed)=0,009) and the influence of Port of Koper significantly lower (Wilcoxon Signed Rank Test $z=-3,713$, Asymp.Sig.(2-tailed)=0,00).

A comparison of the two survey with that of the experts ranking of impacts on noise pollution is shown on Graph 6.17.

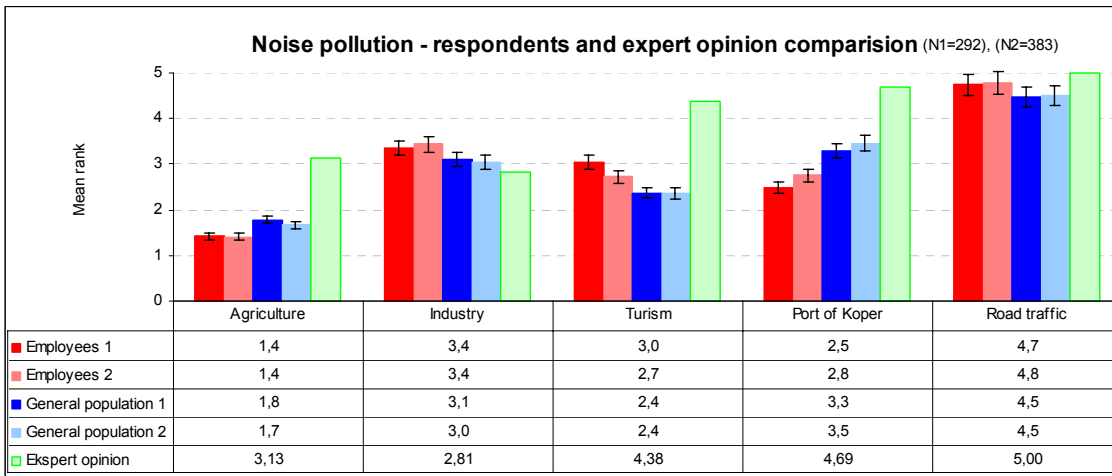

Graph 6.17: Comparison of both surveys results for general population and employees, compared to expert opinion

Risk to human health from environmental factors

Respondents were asked in question Q-11 (Q-18) to rank risk to human health from the following environmental factors: air pollution, drinking water pollution, soil pollution, chemicals in food, nuclear power plants, radon in homes.

For a more detailed analysis and graphs, see APPENDIX 4, Graph A4/4.54 – 4.59 and Table A4/4.31-4.32.

According to the cumulative results, respondents consider that the chemicals in food pose the greatest risk to human health from environmental factors (mean=3,2). The second most hazardous is water pollution (mean=3,0) closely followed by air pollution (mean=2,9) and soil pollution (mean=2,71). Radon in homes is in the fifth place (mean=2,2) while nuclear power plants are considered to represent the smallest risk (mean=2,0). The two surveys give similar results with no statistically significant differences in the answers.

There are however some significant differences in opinions among the selected social groups. The most consistent one is the difference in the perception of risk between males and females, where female respondents grade the statement significantly higher the following environmental threats (Kruskal Wallis Test):

- air pollution (mean_{fem}=3,1, mean_{male}=2,8) ($\chi^2 = 7,372$; Asymp. sig. = 0,007),
- water pollution (mean_{fem}=3,1, mean_{male}=2,9) ($\chi^2 = 6,22$; Asymp. sig. = 0,013),
- soil pollution (mean_{fem}=2,9, mean_{male}=2,6) ($\chi^2 = 8,894$; Asymp. sig. = 0,003),
- nuclear power (mean_{fem}=2,2, mean_{male}=1,9) ($\chi^2 = 5,156$; Asymp. sig. = 0,023).

There is a correlation between opinions between risk from air pollution with employment, where employed and unemployed respondents rank the risk from air pollution lower (mean = 2,8 – 3,0) than retired respondents or students (mean=3,1-3,2) (Spearman's $\rho=0,158$, sig (2-tailed)=0,007).

Another correlation that exists is between age and opinion on radon in homes (Spearman's $\rho=0,193$, sig (2-tailed)=0,02).

Respondents from different locations also grade air pollution significantly different (Friedman $\chi^2 = 21,844$; Asymp. sig. = 0,001). It is graded higher by respondents in Zg. Skofije (mean=3,0) and Bertoki (mean=3,2).

Differences in opinion between employees and the general population occur only in the first survey where the risk from soil pollution was graded significantly lower by employees (mean=2,2) than by the general population (mean = 2,8)) (Wilcoxon Signed Ranks Test: z=-2,689, Asymp. Sig. (2-tailed) = 0,007). The risk to human health posed by water pollution was in the 1st survey graded significantly lower by employees (mean=2,5) than by the general population (mean = 3,0) (Wilcoxon Signed Ranks Test: z=-2,689, Asymp. Sig. (2-tailed) = 0,007).

A very high percent of respondents “don’t know” the risks posed by radon in homes (38,6% in 1st survey and 33,2% in 2nd survey).

Comparison of results according to both groups shows, that there are differences in opinion between them. There are significant differences in ranking risks to human health from environmental factors among respondents of different gender, on all issues, where female respondents rank all risks higher than male respondents. Group of employees grades risk from all environmental factors lower than group of general population in both surveys, but difference in results is not statistically significant and could be attributed to different groups gender structure. We can see that respondents of both groups ranked most of risks to human health from environmental factors higher in 2nd survey.

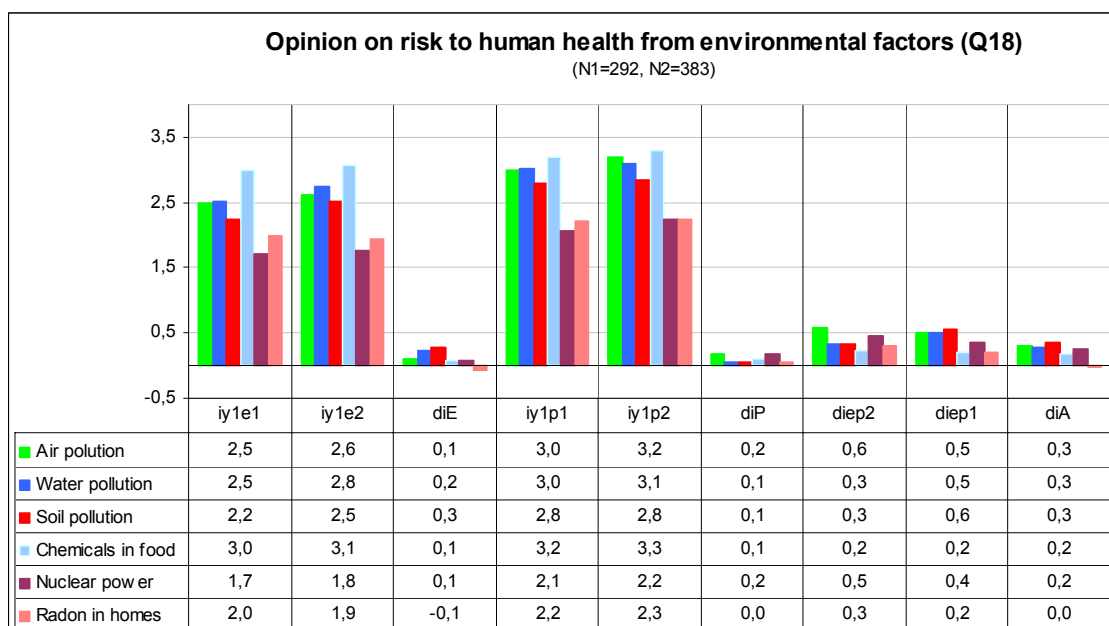

- $y_{(5-18)e}^1$ - sample mean result for employees (e) in the 1st survey (Graph: y5-18e1)
- $y_{(5-18)e}^2$ - sample mean result for employees (e) in the 2nd survey (Graph: y5-18e2)
- $y_{(5-18)p}^1$ - sample mean result for general population (p) in the 1st survey (Graph: y5-18p1)
- $y_{(5-18)p}^2$ - sample mean result for general population (p) in the 2nd survey (Graph: y5-18p2)
- 5-18 - index, marking partial results for variable Y5, represented by result from the question Q-8
- $\Delta E_{(5-18)}$ - difference between 1st and 2nd survey results for employees (Graph: dE5-18)
- $\Delta P_{(5-18)}$ - difference between 1st and 2nd survey results for general population (Graph: dP5-18)
- $\Delta ep_{(5-18)}^1$ - difference in 1st survey between employees and general population (Graph: d5-18ep1)
- $\Delta ep_{(5-18)}^2$ - difference in 2nd survey between employees and general population (Graph: d5-18ep2)
- $\Delta A_{(5-18)}$ - common difference for both groups in both surveys (Graph: dA5-18)

Graph 6.18: Opinion about risk to human health

Variable Y6: opinion about the Port of Koper environmental impact

Respondents were asked (Q-12) to rank the magnitude of the environmental impact of the Port of Koper according to the following environmental factors: air pollution, marine pollution, soil pollution, waste production, noise generation, alien species introduction, storage of hazardous materials, road accidents, ship accidents, rail accidents.

Detailed analysis and graphs are presented in APPENDIX 4, Graph A4/53 – 57 and Table A4/36-44.

Respondents ranked the storage of hazardous materials as the most important environmental concern (mean=3,6) followed by marine pollution (mean=3,5) and waste production (mean=3,44). Concern about road accidents was ranked fourth (mean=3,3), air pollution fifth (mean=3,3) and noise generation the sixth (mean=3,1). To rail accidents (mean=2,9) and shipping accidents (mean=2,9) respondents express less concern and alien species introduction (mean =2,9) and soil pollution (mean=2,8) was ranked the lowest.

There is correlation between gender and opinions of respondents about the ports impact. Differences in opinions among male and female respondents are significant in answers about air pollution, (Kruskal Wallis $\chi^2=8,219$; Asymp. Sig. = 0,004), marine pollution (Kruskal Wallis $\chi^2=15,94$; Asymp. Sig. = 0,0), soil pollution (Kruskal Wallis $\chi^2=10,022$; Asymp. Sig. = 0,002), waste production (Kruskal Wallis $\chi^2=9,261$; Asymp. Sig. = 0,002), alien species introduction (Kruskal Wallis $\chi^2=8,946$; Asymp. Sig. = 0,003) and impact due to the storage of hazardous materials (Kruskal Wallis $\chi^2=7,418$; Asymp. Sig. = 0,006).

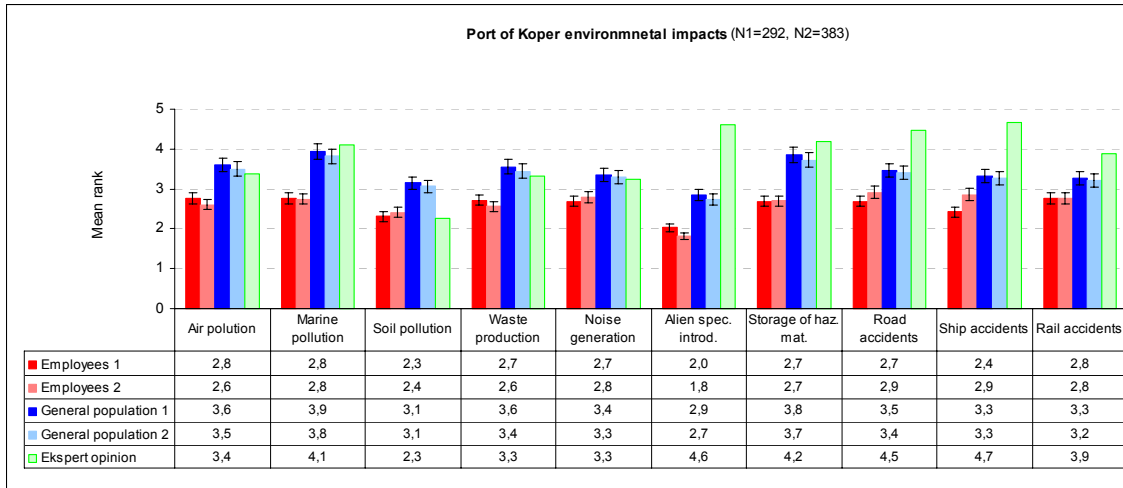

Graph 6.19: Opinion about Port of Koper environmental impact in comparison to expert opinion

There is also a correlation between respondents with opinions about the Ports impact on marine pollution and age (Spearman's $\rho=-0,218$, sig (2-tailed)=0,0), where younger respondents express more concern than older groups.

Significant differences occur when making a comparison between opinions of respondents' from different locations on air pollution (Friedman $\chi^2=16,473$, $df=5$, $Asym.sig.=0,006$), which is graded highest by respondents from Bertoki (mean=4,3) and Ankaran (mean=4,0) and lower by respondents from the City of Koper and Sp. Skofije (mean=3,3). Respondents in Ankaran grade most of the Port's influences significantly higher than respondents from other locations do.

Correlation between gender and the opinions of respondents occur again in the 2nd survey regarding air pollution (mean_{male}=3,3, mean_{fem}=3,7, Spearman's $\rho=0,167$, Sig. (2-tailed)=0,000), marine pollution (mean_{male}=3,6, mean_{fem}=4,1, Spearman's $\rho=0,239$, Sig. (2-tailed)=0,000), waste production (mean_{male}=2,9, mean_{fem}=3,3, Spearman's $\rho=0,247$, Sig. (2-tailed)=0,000) and alien species introduction (mean_{male}=2,6, mean_{fem}=2,9, Spearman's $\rho=0,120$, Sig. (2-tailed)=0,021).

Another correlation can be seen when comparing response and employment, where unemployed and retired respondents rank air pollution, shipping accidents, road and rail accidents higher than do employed respondents (Spearman's $\rho=0,120$ (0,211, 0,124, 0,155), Sig. (2-tailed)=0,020 (0,00, 0,017, 0,003)).

Respondent's age and their opinion on marine pollution and risk from road accidents also shows correlation. Younger respondents grade the risk from road accidents lower than older respondents do (Spearman's $\rho=0,119$, Sig. (2-tailed)=0,022) whereas the situation is opposite with regards to marine pollution in that younger respondents grade it higher (Spearman's $\rho=-0,109$, Sig. (2-tailed)=0,034).

Results of the 2nd survey show a similar pattern to the first survey, although respondents from the general population grade some of the Ports' environmental impacts lower than in the 1st survey. Significant differences occur in the opinions expressed about the impact on air pollution (mean₁=3,6; mean₂=3,5, Wilcoxon S.R. Test $z=-2,939$, $Asymp.Sig.(2-tailed)=0,003$), marine pollution (mean₁=3,9; mean₂=3,8; Wilcoxon S.R. Test $z=-3,006$, $Asymp.Sig.(2-tailed)=0,003$), noise generation (mean₁=3,4; mean₂=3,3; Wilcoxon S.R. Test $z=-2,547$, $Asymp.Sig.(2-tailed)=0,011$), road accidents (mean₁=3,5; mean₂=3,4, Wilcoxon S.R. Test $z=-2,754$, $Asymp.Sig.(2-tailed)=0,006$) and rail accidents (mean₁=3,3; mean₂=3,2, Wilcoxon S.R. Test $z=-2,312$, $Asymp.Sig.(2-tailed)=0,021$).

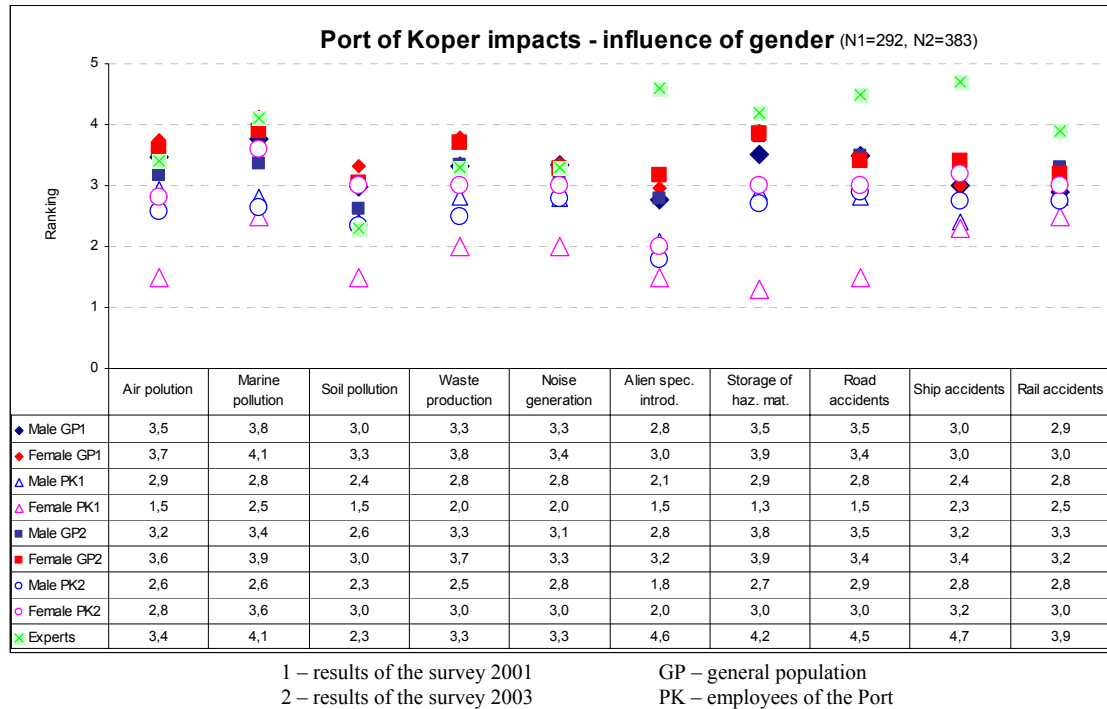

Graph 6.20: Opinion of employees and general population groups divided by gender (mean ranks)

Quantitative comparison of both groups is presented in the Table 6.5.

Table 6.5
 Quantitative data – opinion about the Port's environmental impact

	$Y_{(6-12)e}^1$	$y_{(6-12)e}^2$	$Y_{(6-12)p}^1$	$y_{(6-12)p}^2$	$\Delta E_{(6-12)}$	$\Delta P_{(6-12)}$	$\Delta ep_{(6-12)}^1$	$\Delta ep_{(6-12)}^2$	$\Delta A_{(6-12)}$
Air pollution	2,8	2,6	3,6	3,5	-0,17	-0,10	0,82	0,90	-0,27
Marine pollution	2,8	2,8	3,9	3,8	-0,03	-0,13	1,16	1,06	-0,15
Soil pollution	2,3	2,4	3,1	3,1	0,11	-0,08	0,84	0,65	0,03
Waste generation	2,7	2,6	3,6	3,5	-0,16	-0,11	0,83	0,89	-0,27
Noise generation	2,7	2,8	3,4	3,3	0,11	-0,06	0,66	0,49	0,05
Alien spec. introduction	2,0	1,8	2,9	2,8	-0,21	-0,11	0,83	0,93	-0,32
Storage of haz. mat.	2,7	2,7	3,9	3,7	0,01	-0,12	1,15	1,02	-0,12
Road accidents	2,7	2,9	3,5	3,4	0,22	-0,05	0,76	0,48	0,17
Ship accidents	2,4	2,9	3,3	3,3	0,44	-0,05	0,90	0,41	0,40
Rail accidents	2,8	2,8	3,3	3,2	-0,01	-0,05	0,48	0,44	-0,05
Sum					0,31	-0,86			-0,62

The results also show how employees of the Port have a significantly different opinion from other respondents on every question in this respect and grade the magnitude of Ports' impact significantly lower than the general population while the general population grades the Port's environmental impact significantly higher than the employees in all issues in both surveys. Respondents from the general population grade all impacts lower in the 2nd survey than in the 1st survey (Table 6,5), whereas employees grade higher soil pollution, noise generation, and hazards due to storage of hazardous materials, road accidents and shipping accidents. If the differences from the calculations are summed, a small raise in the general ranking of the Port's impact by employees ($\Sigma \Delta E_{(6-12)} = 0,3$) and a decrease in the ranking of the Port's impact by the general population ($\Sigma \Delta P_{(6-12)} = - 0,9$) becomes apparent. Statistically that the changes in the respondents opinions on the storage of hazardous materials, marine pollution, waste generation, road accidents, air pollution and alien species introduction are significant.

Variable Y7: Moral responsibilities towards environmental issues and trust in technological development and technological solutions to environmental problems

Respondents were asked (Q-13) to rank on the level of 1-4: (1=do not agree at all; 4=strongly agree) their agreement with the following statements

- a.) We believe too much in science and technology and too little in intuition and feelings.
- b.) Modern science is causing more harm than good.
- c.) Any change in the environment, caused by human activity, no matter how scientifically founded, is harmful.
- d.) Modern science will solve all environmental problems without us having to change our life style.
- e.) We worry too much about our future and our environment and not enough about inflation and employment at present.
- f.) Nearly everything we do is harmful to the environment.
- g.) We worry too much that the development of a modern technological society will harm the environment.

Detailed analysis and graphs are presented in APPENDIX 4, Graph A4/58 – 61 and Table A4/45 -49. Mean results are presented in Table 6.6:

Table 6.6
Results of 2001 and 2003 survey - Means – Agreement with statements

	N ₁	Mean 1	Std. Deviation ₁	N ₂	Mean 2	Std. Deviation 2
(a) Too much science	255	2,6	0,8	360	2,7	0,8
(b) Harmful science	257	2,5	0,9	364	2,3	0,8
(c) Harmful human impact	256	2,4	0,9	364	2,6	0,9
(d) Technological fix	257	2,1	0,8	357	2,0	0,8
(e) Too much concern for the environment	260	2,3	0,9	371	2,2	0,9
(f) Everything we do is harmful	262	2,6	0,8	370	2,6	0,8

The results show, that the respondents find the statement (a) 'We believe too much in science and technology and too little in intuition and feelings' most agreeable (mean=2,6). There is significant difference in opinion among respondents with a different level of education, where students show the highest agreement with the statement (mean=3,14). The lowest level of agreement is found among respondents with primary education (mean=2,4) (Kruskal Wallis Test $\chi^2=14,168$, Asymp.Sig. = 0,015).

Statement (b) 'Modern science is causing more harm than good' was also graded high (mean=2,6). A correlation between this statement and gender; analysis reveals that female respondents grade this statement with a mean=2,6 while male respondents with the mean=2,4 (Spearman's $\rho=0,146$, sig. (2-tailed)=0,019). In the 2nd survey this statement was given the lowest grade by students (mean=2,0 – 2,1) and by respondents with a high education (mean=2,2).

There is a significant difference in analysis according to:

- employment, where employed respondents (mean=2,3), grade the statement lower than unemployed (mean=2,4) or retired respondents (mean=2,5) (Kruskal Wallis $\chi^2=6,06$, df=2, Asymp. Sig.=0,048),
- location (Friedman $\chi^2=14,154$, Asymp.Sig.=0,015) and group of respondents from Port of Koper, who grade it the lowest (mean=2,2), respondents from Hrvatini gave it the highest grade (mean=2,7) and
- time - respondents grade it significantly higher is the 1st than in the 2nd survey (Wilcoxon z=-2,100, Asymp. Sig. (2-tailed)=0,036).

There is also a correlation between age and the agreement with statement (b), where younger respondents (mean=2,2) grade it lower than older respondents do (mean=2,5) (Spearman's $\rho=0,128$, Sig.(2-tailed)=0,015).

The difference in opinion about statement b.) between employees and the general population is not statistically significant.

Statement (c.)' *Any change in the environment, caused by human activity, no matter how scientifically founded, is harmful* was graded with the mean=2,4 in the 1st survey. There is a correlation among education and opinions on this (Spearman's $\rho=0,108$, Sig.(2-tailed)=0,039). The statement is graded highest by respondents with no education (mean=3,1) and the lowest by respondents with a high education (mean=2,5).

There is also a statistically significant difference in opinion about this question according to employment, where employed respondents (mean=2,5), grade the statement lower than unemployed (mean=2,8) or retired respondents (mean=2,7) (Kruskal Wallis $\chi^2=6,937$, df=2, Asymp. Sig.=0,031).

Opinion on the statement (d.) *Modern science will solve all environmental problems without us having to change our life habits* correlates with:

- employment status (Spearman's $\rho=0,106$, df=2, Sig.(2-tailed)=0,018), where employed respondents (mean=1,9) grade the statement lower than non-employed (mean=2,0) or retired respondents (mean=2,1);
- age, where younger respondents (mean=1,9) grade the statement lower than older respondents (mean=2,5). (Spearman's $\rho=0,107$, Sig.(2-tailed)=0,043);
- and in the 2nd survey in with gender (Spearman's $\rho=0,13$, Sig (2-tailed)=0,012, N=370), where female respondents grade the statement (mean=2,7) significantly higher than male respondents (mean=2,5) (Kruskal Wallis $\chi^2=6,22$, Asymp. Sig.=0,013).

Significant differences in the groups of respondents occur in opinion on this statement and:

- education level: respondents with no- (mean=2,4) graded the statement significantly higher than respondents with high education (mean=2,2). (Kruskal Wallis $\chi^2=17,54$, df=5, Asymp. Sig.=0,004);
- location: (Friedman $\chi^2=25,35$, Asymp.Sig.=0,00); it is found that respondents from the Port and Bertoki (mean=1,8) grade it the lowest, whereas respondents from Hrvatini give it the highest grade (mean=2,7).

Statement (e) *'We worry too much about our future and the environment and not enough about Inflation and employment at present'* was graded relatively high (mean=2,5). There were no significant differences identified in the 1st survey.

In the 2nd survey however significant differences occur according to:

- education, where students (mean=1,8) and respondents with high education (mean=2,0) express the lowest agreement to the statement. Respondents with medium (mean=2,3) and no education (mean=2,4) grade it a bit higher, the highest agreement is expressed by respondents with primary education (mean=2,5). (Kruskal Wallis $\chi^2=21,32$, df=5, Asymp. Sig.=0,001) and
- location (Friedman $\chi^2=19,618$, Asymp.Sig. =0,003), where respondents from Spodnje and Zgornje Škofije (mean=2,0) grade it the lowest, whether respondents from Hrvatini give it the highest grade (mean=2,7).

There is also a correlation between employment and opinion on this question (Spearman's $\rho=0,122$, Sig. (2-tailed)=0,019), where employed respondents (mean=2,1) grade the statement lower than unemployed (mean=2,1) or retired respondents (mean=2,4).

Statement (f) *Everything we do is harmful to the environment* was graded high. Analysis reveals a significant correlation between statement f.) and age, which shows that younger respondents (age 18-25, mean=2,8; age 66-, mean=2,4) grade the harmful effects of human activities higher than older respondents do. (Spearman's $\rho=-0,146$, sig(2-tailed)=0,018).

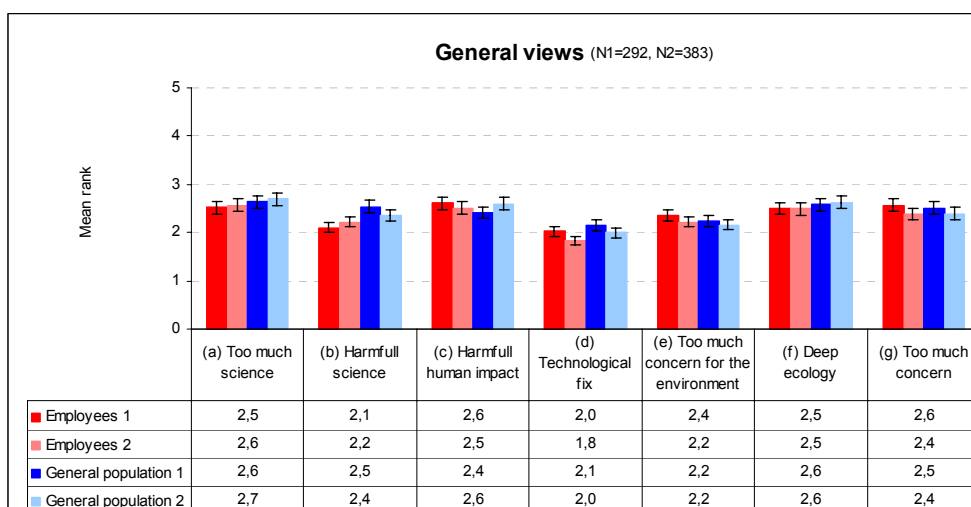

Graph 6.21: Opinion about general views and opinions

Statement (g.) *We worry too much that the development of a modern technological society will harm the environment* was graded with a mean=2,5. There is a significant difference in opinion with regards to education. Respondents with no education grade the statement with a mean=2,9, compared to respondents with a higher education and students who grade the statement significantly lower (mean=2,2) (Kruskal Wallis Test $\chi^2 = 12,836$, Asymp. Sig. = 0,025).

Table 6.7 gives an overview of opinion on all the questions about variables influencing trust in science and technology and in technological solutions of environmental and the influence of gender (G), education (E), age (A), employment (Em), location (L), time (T) and differences between general population and employees (G/E). Significant differences are marked with grey fields. The influence of extraneous variables (education, employment status, gender and age) is identified in all issues. We can see that general views do not differ significantly between the group of employees and respondents from the general population, except for statement b.) but are more influenced by other factors.

Table 6.7
Variables influencing trust in science and technology and in technological solutions of environmental problems

Statements	G	E	A	Em	L	T	G/E
We believe too much in science							
Modern science is causing more harm then good							
Any change in environment is harmful							
Modern science will solve all env. problems							
We worry too much about our future and environment							
Everything we do is harmful to environment							
We worry too much about harming env.							

G – gender
L – location

E – education
T – time

A – age

Em – employment

G/E – general population / employees

 - impact of extraneous variable on results

The results from both surveys are similar, except for point *b*) '*Modern science is causing more harm than good*', where respondents from the general population grade it significantly lower in the 2nd survey than in the 1st survey ($z = -2,056$, Asymp. Sig. (2-tailed)=0,040) ($\Delta P = -0,18$) and in *c*) '*Any change in the environment, caused by human activity, no matter how scientifically founded, is harmful*', which is graded significantly higher in the 2nd survey ($z = -2,071$, Asymp. Sig. (2-tailed)=0,038) ($\Delta P = 0,17$).

With the exception of the response to statement *b*), where respondents from the general population grade it significantly lower in the 2nd survey than in 1st survey (Wilcoxon Signed Rank Test $z = -2,056$, Asymp. Sig. (2-tailed)=0,040) ($\Delta P = -0,18$) and to statement *c*) which is graded significantly higher in the second survey (Wilcoxon Signed Rank Test $z = -2,071$, Asymp. Sig. (2-tailed)=0,038) ($\Delta P = 0,17$) the results of both surveys are similar

From the analysis of the extent of trust in technological development and moral responsibility toward the environment we find agreement between both main groups and can conclude that respondents think *we believe too much in science and technology* and that *nearly every human activity is harmful to the environment, no matter how scientifically founded it is*. On the other hand, people also think *we worry too much that the development of a modern technological society will harm the environment*, since they ranked it similarly to the previous statement. This shows, that opinions about these issues are not very strong. Respondents do not support strongly the idea that *modern science is causing more harm than good*. In addition they do not think that *we worry too much about our future and the environment, and not enough about present prices (inflation) and employment*. The least supported statement was *modern science will solve all environmental problems without us having to change our lifestyles*.

Variable Y8: the extent, to which respondents are ready to participate in environmental protection

Respondents were asked in question (Q14-1st)/ (Q-15-2nd) to rank (1-4) their readiness to participate in environmental protection. The questions were as follows:

- a) Would you be ready to pay higher prices for goods in order to protect the environment?
- b) Would you be ready to pay higher taxes in order to protect the environment?
- c) Would you be ready to lower your standard of living in order to protect the environment (simple food, less tourism, smaller use of luxurious items)?
- d) Are you collecting your waste separately?
- e.) If you are not collecting all your waste separately yet - would you do it, if you could?
- f.) Are you recycling everything that is possible to recycle?
- g.) Are you ready to use your car less in order to protect the environment if the public transport would be available?
- h.) Are you ready to lower your energy consumption?
- i.) Would you be ready to pay higher prices for some products, because the Port of Koper wishes to implement a better environmental protection program?

More detailed analysis and graphs are presented in APPENDIX 4, Tables A4/50-63.

Protection of the environment vs. lower standard of living and higher prices

There was neither a significant difference nor a correlation among the different groups regarding question (a). Respondent's readiness to pay higher prices was graded by the mean=2,6 on the scale 1-4, which shows that respondents are not enthusiastic about the idea. Respondents graded the question in first survey lower (mean=2,6) than in the second survey (mean=2,8).

Question *b*): *Would you be ready to pay higher taxes in order to protect the environment?* was graded similarly to question (a). There is a weak correlation between education and opinion on taxation (Spearman's $\rho = -0,120$, Sig. (2-tailed)=0,023), where students (mean=3,0) and respondents having a high education (mean=3,0) grade their readiness to pay higher taxes higher than respondents with medium (mean=2,8) or lower education. There are significant differences among opinions of respondents from different locations that are attributable to the different groups' education structure. Respondents grade their readiness higher in the 2nd

survey (mean=2,9) than in first survey (mean=2,6) although the difference is not statistically significant.

All respondents graded their answers to question c) higher (mean =2,7). There are no significant differences among the different groups of respondents in the 1st survey. Results of both surveys are similar, although differences among the Port employees and residents in the surrounding area increased. The major difference is in the opinions expressed by the employees of the Port in both surveys (mean₁=2,2, 2nd mean₂=3,5, Wilcoxon Signed Ranks Test (Z)= -4,290, Asymp. Sig. (2-tailed) =0,000). There is also significant difference in opinion in the 2nd survey between respondents with differing levels of education, where respondents with a high education (mean=3,1) and students (mean=3,0) grade their readiness to accept a lower standard of living higher than respondents with a medium (mean=2,7), primary (mean=2,5) or with no education (mean=2,7). (Kruskal Wallis Test $\chi^2 = 13,518$, Asymp. Sig. = 0,019).

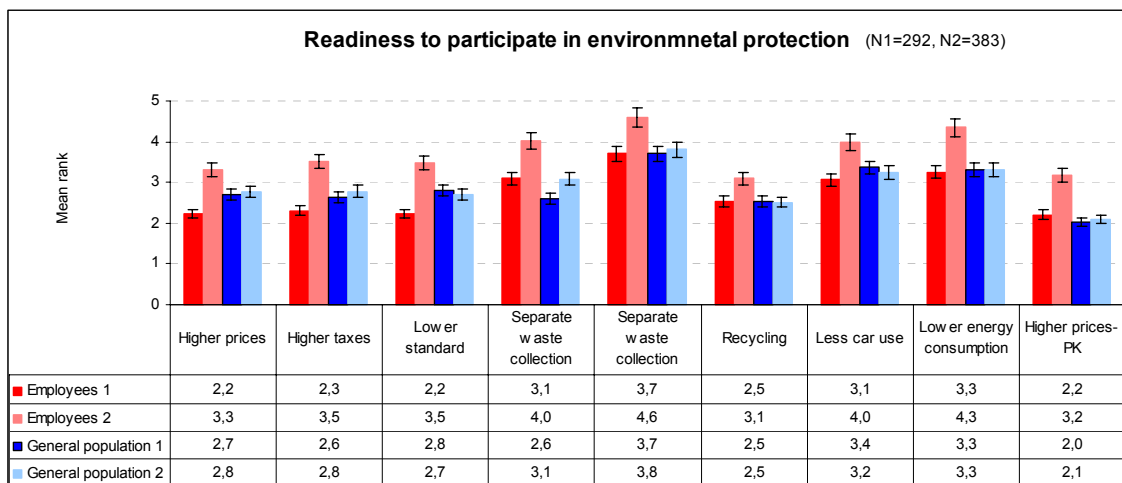

Graph 6.22: Readiness to participate in environmental protection

Waste collection and recycling

Respondents rank question d) with a mean grade=2,7 and mean=3,1 in the 1st and 2nd survey respectively. There is a correlation between the answer to this question and age (Spearman's $\rho = 0,142$, Sig. (2-tailed) = 0,021). Respondents in the age group 56-65 were the most willing to separate waste for collection (mean=3,0). There is also a significant difference in the analysis of answers according to location. Respondents in Ankaran and Bertoki grade their existing separate waste collection scheme much lower than other respondents (mean=2,2), whereas those from the City of Koper (mean=3,0) and employees of the Port (mean=3,1) grade it higher. Statistical analysis also shows that differences are significant (Friedman $\chi^2=20,297$, df=6, Asymp. sig.=0,002). The reason for a high level of separate waste collection in the Port is due to company policy, since strict rules govern the collection of waste within the Port.

Respondents grade their answers to question e.) *If you are not collecting all your waste separately yet - would you do it, if you could?*, highly shows that the respondents would be ready to cooperate, given the chance (mean=3,7). There is a correlation between the response to this question and age, where respondents in aged 26 – 45 display the highest willingness to separate waste for collection (Spearman's $\rho = 0,135$, Sig. (2-tailed) = 0,031). Results of the second survey are similar to the first one in the sense that there is a statistically significant difference among the different employment groups in the 2nd survey (Kruskal Wallis Test: $\chi^2=10,255$, df=3, Asymp.Sig.=0,017). The pattern is similar in the response to question d) - unemployed respondents (mean=3,8) rank their readiness separate waste lower than other employed respondents (mean=3,9) and students (mean=4,0).

The pattern of answers to f) are similar to answers given to d) and e) and there is a correlation between the respondent given opinions and age, where the highest level of recycling is

achieved by respondents aged between 56-65 (mean=3,2) (Spearman's $\rho = 0,135$, Sig. (2-tailed) = 0,031). There are also differences with respect to employment status, where the lowest rate of recycling is achieved by students (mean=1,6) (Kruskal Wallis Test: $\chi^2=13,439$, Asymp.Sig.=0,004). Another difference is the in opinions on recycling among respondents from different locations (Friedman: $\chi^2=17,757$, Asymp.Sig.=0,007). Overall the results from both surveys are similar, but there are positive differences between Ankaran, Bertoki, Sp. Škofije and Zg. Škofije and a negative difference in the City of Koper.

Car use and energy consumption

From the response given to question g) '*Are you ready to use your car less in order to protect the environment if the public transport would be available?*', it is clear that respondents are ready to consider this idea. There is a significant difference in opinions among employed/non-employed, retired respondents and students, where retired respondents show the biggest (mean=3,5) and students show the lowest (mean=2,6) willingness to exchange cars for public transportation (Kruskal Wallis Test: $\chi^2=8,161$, Asymp.Sig.=0,043). Results of both surveys are very similar (mean=3,3) although the difference in the opinions expressed from different locations is statistically significant (Friedman : $\chi^2=20,857$, Asymp.Sig.=0,002) with the greatest difference being found among the opinion of the employees of the Port (*Graph 6.22*) (Wilcoxon Signed Ranks Test (Z)=-3,591, Asymp. Sig. (2-tailed) =0,000).

All respondents grade answers to question h.) with a mean grade 3,3. There is a statistically significant difference in opinion among male and female respondents, where women show a greater willingness to reduce energy consumption (Kruskal Wallis Test: $\chi^2=3,911$, Asymp.Sig.=0,048). With the except of the general opinion of respondents from the Port the results of the 2nd and 1st survey are similar, (mean₁=3,3; mean₂=3,8; Wilcoxon Signed Rank Test Z = -2,612, Asymp. Sig. (2-tailed) = 0,009).

Protection of environment in the Port of Koper vs. higher prices

Respondents grade their answers to the statement i) '*Would you be ready to pay higher prices for some products, because the Port of Koper wishes to implement better environmental protection program?*' low with an average grade of 2,1 and there are no significant differences among groups of respondents. The results of both surveys are similar for respondents from the general population and Port employees but a significant difference does occur in the opinions expressed by the employees of the Port in 1st and 2nd surveys since they grade their readiness to participate in environmental protection significantly higher in second survey on all issues.

Correlation of statement blocks

The goals of the society are related to the moral responsibility to environmental issues, therefore this study has checked to see if there are any associations between statements about moral responsibility to environmental issues, trust in technological solution of environmental problems (Y7) and the value structure of the society (Y3).

Respondents, who grade a *clean and healthy environment* high, grade the statement "*Modern science is causing more harm than good*" with undetermined answers (grades 2-3 on the scale 1-4) (Spearman's $\rho = 0,128$, Sig (2-tailed) = 0,47). At the same time they give a low grade to the statement "*Any change in environment, caused by human activity, no matter how scientifically founded, is harmful*" (most answers 2 on the scale 1-4) (Spearman's $\rho = 0,219$, Sig (2-tailed) = 0,001). This is interpreted so, that the respondents do believe in scientific and technological development bringing about solutions for the current environmental issue.

Another interesting correlation is between the importance of a *stable economy* and the statement "*Modern science will solve all environmental problems without us having to change our life habits*" (Spearman's $\rho = 0,134$, Sig(2-tailed) = 0,038). Respondents who grade the importance of a *stable economy* high (grade 4-5 on the scale 1-5), grade the '*technological fix*'

statement relatively low (grade 2 on the scale 1-4) which we interpret as the respondents' awareness that our lifestyles will have to change in order to bring about sustainability.

The level of agreement with the statement "*Environment has to be protected even if it means fewer jobs in the local community.*" correlates to the statement "*Any change in the environment, caused by human activity, no matter how scientifically founded, is harmful*" (Spearman's $\rho = 0,227$, Sig(2-tailed) = 0,00). The respondents who express a strong support for *environmental protection vs. jobs in the community* rank the harm caused by human impacts on the environment high, although the majority of respondents do not hold strong opinions on these issues.

This study has also identified significant correlations between opinions on the statement "*Environment has to be protected even if it means less jobs in local community.*" and the opinion on *stable economy* importance (Spearman's $\rho = 0,148$, Sig(2-tailed) = 0,014) and between opinions on the "*Environment has to be protected even if it means less jobs in local community.*" and the importance of *clean and healthy environment* (Spearman's $\rho = -0,214$, Sig(2-tailed) = 0,00). All those respondents, who express a strong support for a *stable economy* and even those who strongly agree with the idea that the *environment needs protecting despite losing jobs in the local community*, do not grade the importance of a *clean and healthy environment* as the most important goal.

Answers concerning recycling correlate with opinions on the importance of a clean and healthy environment, where (not surprisingly) those respondents who think a clean and healthy environment is important are more likely to recycle (Spearman's $\rho = 0,182$, Sig(2-tailed) = 0,005).

6.4 Results aggregation

From the analysis in the previous sections a table was compiled to present those variables that influence the results (gender, age, education, employment, location of residency and time) and the significant differences in opinions between the general population and employees (*Table 6.8*).

Analyses shows that respondent's gender has a significant impact on perception of environmental quality in the coastal zone and of the Port's environmental impacts. Gender also has an impact on trust in technological solutions of environmental problems and moral responsibility towards the environment. The impact of gender was identified in the first survey as having a significant influence on opinions about trust to sources of information.

Education plays an important role too, especially in trust to sources of environmental information; trust in technological solutions of environmental problems and moral responsibility for environmental issues and the readiness for participation in environmental protection.

Age influences all issues except opinions on the priorities in an industrial activity development. A consistent significant impact was detected on trust in sources of environmental information, value structure, readiness to risk material safety in order to protect the environment and readiness for participation in environmental protection.

Employment is another important factor that influences the readiness to risk material safety to protect the environment, perception of environmental quality in the coastal zone and the extent of trust in a technological solution and environmental ethics. The impact of employment was identified in first survey as having a significant influence on trust in sources of environmental information, value structure of the society and opinion on the Port's environmental impacts.

Residency of respondents has impact on priorities in industrial activity development, perception of environmental quality in coastal zone and the extent of trust in technological solution and environmental ethics. Impact of location was identified also in first survey as having significant influence on trust in sources of environmental information and opinion on port of Koper environmental impacts.

Important changes over time were identified concerning the opinions expressed by respondents about the priorities in an industrial activity development, value structure of society, perception of environmental quality in coastal zone, opinion on Port's environmental impacts and the readiness to participate in environmental protection. Impact of time was identified also in some locations as having a significant influence on trust in sources of environmental information.

Differences between the general population and employees are consistently significant and reveal the important impacts of institutional constraint in trust in sources of environmental information, in answers about priorities in industrial activity development and the opinion of respondents about the Port's environmental impacts. Differences between both groups were identified in their readiness to risk material safety to protect the environment and their perception of the environmental quality in coastal zone, which is assigned to the different employment structure of the two groups. Differences over opinions on the level of trust in a technological solution to environmental problems and opinion on ethical issues and readiness for participation in environmental protection are assigned to education and age.

Coloured fields in the table mark:

- bold - variables, detected at few locations or in only one of the surveys that can have potential impact on the differences of the views between general population and employees, but were not consistently identified in both surveys;
- orange - variables, which can be the cause of differences between general population/employees due to the different group structure and were detected in both surveys,
- red - where the statistical analysis shows strong correlation or difference in both surveys;
- yellow - the differences between the general population and employees, which are assigned to different groups structure.

Table 6.8
Variables that influence results

	G	Edu	A	Empl	L	T	Gp/E
Y ₁ – trust in sources of environmental information							
Y ₂ – priorities in industrial activity development							
Y ₃ – value structure on which society depends							
Y ₄ – readiness to risk material safety in order to protect the environment							
Y ₅ – perception of environmental quality in coastal zone							
Y ₆ – opinion about port of Koper environmental impacts							
Y ₇ – the extent of trust in technological solution and environmental ethics							
Y ₈ – readiness for participation in environmental protection							

G – gender
T – time

Edu – education
Empl – employment

A – age
L – location

Gp/E – general population / employees

- no detected impact of variable
- variable, detected on few locations or only in one of the surveys
- variable, considered to be the cause of differences between general population/employees
- variables, detected consistently in both surveys;
- difference between general population/employees is assigned to different groups structure

7. DISCUSSION

7.1 General

In response to questions about the perception of environmental issues in the coastal zone, this study identifies differences in ranking answers provided by the sample groups when compared to expert opinion. The impact of tourism and road traffic on air pollution and the impact of the tourism and marine traffic on the marine environment are underestimated by the respondents. From this, we can assume that these environmental pressures are similarly perceived by both groups. We can explain this systematically low grading by the theory of social constructivism (*The New Encyclopaedia Britannica (NEB) II, 1992*), where 'consensus between individuals judges the truth according to constructions on which most respondents agree' and results in the lack of serious actions to minimise it.

When grading the Ports' impacts the biggest difference between respondents and experts is in opinion on alien species introduction. Given the high percentage of 'don't know' answers from the survey, the issue is obviously unfamiliar to many respondents. The analysis of the survey results shows that the local population grade the Port's environmental impacts i.e., air, marine and noise pollution significantly higher than employees. We can deduce from this that institutional constraint is the variable, which consistently influences the perception of environmental impacts and confirms the findings of Alhakami and Slovic (1994), who claim that expected benefit from a technology influences perception of environmental issues. According to the general definition of perception (*NEB I, 1992*) and to socio-environmental and risk perception studies (*Dunlap, 2002, NEB II, III, 1992*), perception is influenced by many factors and it is difficult to determine precisely from the results, which of the factors is more important – familiarity, knowledge or institutional constraint i.e., the expected benefit from the activity. Besides being economically dependent, employees of the Port are more familiar with the Ports activity, although the Port has existed for the last 50 years and has made numerous public presentations about its activity during this period, so the Port's activities should be familiar to the general population, too.

Motivations of society are attributed to many factors, as shown in Stern *et. al.*'s causal model of environmental concern (*Bectel, 1997*), where attitudes, values and beliefs are tied into belief systems. In order to get a better understanding of the respondent's motivations, we address their general views and opinions together with the value structure of the society. We found that people are mostly concerned for material safety (*stable economy*), which must be assured before concern about environmental protection, but *rapid economic growth* comes after that. Our interpretation of this is that people would consider the environmental consequences of certain activities, which would bring about rapid economic growth if their material safety were already assured.

Age is the most important variable that influences value structure especially in opinions on having a *clean and healthy environment, humane society* and *freedom of speech*, with *humane society* and *freedom of speech* being more important to the older group (65+ years). We attribute this to their experience of living under the socialist regime in the former Yugoslavia, since we believe that the present democratic society does not limit freedom of speech or human rights. Both surveys give similar results concerning the need for a *clean and healthy environment*, but there is a significant decline expressed in the need for a *stable economy* with an increase in the desire for a *humane society* and greater *freedom of speech*. We attribute this to the positive economic changes in Slovenia occurring over the last two years (*Statistical Office of the Republic of Slovenia*) and to the debate in society regarding human rights prior to joining the EU. Another interesting result is that respondents with primary education grade a clean and healthy environment as a higher goal than respondents with a university education do, a fact that rules out our conviction that people with a higher education have a greater awareness of environmental issues.

Ethical issues in this study were addressed by posing questions about the impacts of a modern society's technological development vs. environmental appreciation. What we found was that

respondents are of the opinion that *"We believe too much in science and technology"* and that *"Nearly everything we do is harmful to the environment."* Students and respondents with a higher education express the lowest agreement to the statement *"We worry too much about our future and environment and not enough about costs of living and employment at present"*. We can see the impact of employment status i.e. personal economic stability on the opinions expressed, since unemployed and retired people, who generally have a lower standard of living, grade this statement higher. The survey group ranked third the claim that *"We worry too much about development of modern technological society harming the environment"*. This suggests that the respondents do support development, but do not believe in technological solutions to environmental problems. They seem to believe more in lifestyle changes, since they express a greater willingness to lower energy consumption and change their living habits relatively high. We can see again the influence of education in this issue where respondents with a high education express a higher readiness to lower their standard of living than respondents with a lower education, which we link also to respondent's personal economic security.

The influence of the extraneous variables: education, employment, gender and age, is identified in all of the opinions expressed in the surveys. Our analysis reveals that people in the Slovene coastal zone put little trust in a *'technological fix'*, a fact supported by the respondents putting as the least likely solution to environmental problems the idea that *"science will solve environmental problems without us having to change our life habits"*. This supports the theories of Korzibsky (1958) who claims that society does not believe in science as a way of determining the truth unless society benefits from it – we might add that society does not believe in science as means of environmental protection either (Carmines and Zeller, 1985). Although we can see that the negative opinion about the impacts of science based technologies is getting less negative, since respondents graded their concern about science significantly lower in the 2003 survey than in the 2001. We attribute this shift in opinion to the increased access of the general population to scientific debate and to the state-led environmental education programs developed since 2001. The state is making extensive efforts to inform society about environmentally related issues and the mechanisms of environmental degradation. Alternatively, respondents do consider the harm done by human activities on the environment to be greater in the 2003 survey than in the first survey, suggesting an increased acknowledgement of their responsibility and connection to environmental degradation.

The survey also attempts to address the economic valuation of environmental protection by posing questions about the readiness of a society to risk material safety to protect the environment. We were able to identify key extraneous factors: employment status, education and age, and found a greater concern for environmental protection by older respondents. Younger respondents are more insecure and concerned about employment expressing stronger support for rapid economic growth. Information about the readiness to participate in environmental protection is also useful information for policy makers in preparing environmental protection action plans. We can see that respondents grade their readiness for separate waste collection very high and that they grade existent waste collection lower in 2001 and higher in 2003. This shows that waste management programs are developing, but that the present level of recycling is still low. Respondents do express their readiness for reducing energy consumption and car use, showing an awareness of environmental issues - unfortunately, the reluctance to change life-habits means they will probably do nothing about it. According to our experience, any limitations in energy consumption and car use are unpopular and require a great deal of organisation and alternative solutions. Respondents are also not in favour of a lower standard of living, higher prices or taxes as a solution, simply because actions that involve monetary contributions are unpopular. This is comparable to opinions expressed about environmental protection vs. jobs in the community. Opinions on environmental protection are influenced by gender and education, where female respondents and those with a higher education rank their readiness for cooperation in environmental protection higher than male respondents and those with a lower level of education.

We tried to find correlations between values and the opinions expressed to determine the extent to which people are willing to participate in environmental protection. We can see that respondents do not hold strong opinions about a clean and healthy environment since the same respondents who graded the importance of a clean and healthy environment high, graded statements about modern science and human activities harmful impacts with medium or low

grades. We can also see, that respondents who grade the importance of a clean and healthy environment high, do not believe in technological solutions to environmental problems, but rather in life style changes. Those respondents, who express a strong support for a stable economy and even those who agree with the idea that the environment needs protecting despite jobs losses in the local community do not grade the importance of a clean and healthy environment as the most important goal. This is further confirmation that people are concerned firstly about their economic safety and only after that about environmental issues.

Consideration of the extent to which the source of information is trusted or distrusted is important in research on environmental perception (Frewer, 1999; Slovic 1993). We were interested in detecting possible distrust in information sources and the influences it has on the information presented during the EIA process. Our results show that respondents expressed the highest level of trust in expert information, but believe that the different media do not effectively present it. We identified a strong influence of institutional constraint in the issue, since employees grade their employer as a trusted, effective and reliable source of information. There is a correlation albeit weak between trust in information and education, but the main differences occur between employees and respondents from the general population in their trust in the information given by the Port authorities and that provided by NGOs. No other consistent influence of extraneous variables was identified, which underlines our hypothesis about the importance of the influence of institutional constraints.

Cvetkovic and Lofstead (1999) wrote about the possibility that trust in the policy maker is dropping. Results did not show any trend in the level of trust in governmental information, but showed that the government is one of the least trusted sources. This is consistent with results of other researches in Slovenia (Kos, 1993; Kos, 2002), which observe and discuss erosion of legitimacy at all governmental/political levels. The results also support the Salient Values Similarity theory (Earle and Cvetkovic 1995) through the expression of increasing trust towards information from NGOs, who supported the 'no action' alternative in the process. The 'no action' alternative is preferred by part of the community and was also expressed during the EIA process hearing.

Our results consistently show differences in perception of environmental issues in relation to the Port by employees and general population, therefore we can conclude that institutional constraints – economic independence is a an important factor that influences environmental perception or at least its' expression, which has already been confirmed by other researchers (Slovic et al., 1998).

7.2 Results in the light of uncertainty

In this research we used the pre- and post- test method, which is uncertain due to possible impacts of different respondents' life experiences in the time between both surveys. As stated before in paragraph 4.8, the reason for not using the classic design of the study with a test and control groups was, that the EIA process is designed on a premise, that everybody should have a possibility to participate in it and that it would be anyhow difficult to claim, that group of respondents from the control group had no access to information In the present information society.

The conduction of the research included a presentation in the EIA process for the Pier III in the Port of Koper, which was expected to raise a lot of debate in the media – but was postponed. We are actually facing this situation now, in 2005, when the discussion about necessity of the Pier III construction involves the whole Slovene society.

As Durkheim wrote (from Seale, 2004), "*progress of science is proven by the progress toward solutions of the problems it treats, when laws are discovered in order to reach the final solution*". In sociology the problems are usually not so clear-cut and involve mainly the clarification of subjects in question. Štebe (1996) and Kos (2002) state in their work, that the most reliable data from survey research are those acquired by comparison, data that should not be taken as absolute, scientific evidence. In this respect we can confirm differences between respondents of

different gender, education or employment and the differences in opinions between employees/non-employees in the Port.

We are aware of the fact that many variables influence environmental perception, even though they were not controlled in this research. Questions arise on three levels of societal change that may have significant influence on public participation in future environmental protection. We could distinguish influences at local, national and global level, which all can have a significant influence on the shaping of public's environmental concern, especially due to an ever increased flow of information. This adds unknown flexibility to the social world and can also significantly influence changes over time in perceptions of environmental issues.

Slovenia went historically through many changes and came through a period of industrialisation to the present service oriented information society. It became an independent country just 10 years before the first survey. In particular this last event brought many changes in the society, economy and politics especially by changing the country from socialist regime to capitalism. The Slovenian society went through a state of euphoria about its independence that was followed by a clash with reality. One of the most important factors for a stable society is a good economic situation, which got worse – there were 15.000 unemployed in 1987, but that number rose to 126.000 in 1998, when this research basically started. The situation improved by 2001 when the first survey took place, while the year 2003 was already marked by expectations for Slovenia's accession to EU. During this time environmental policy got a more important role in the society – with improved scientific knowledge, an improved environmental protection policy and with many efforts to raise public awareness of environmental issues. These events have been considered in the study, but were not statistically tested, although it can be expected that they have had an influence on the environmental perception.

Table 6.8 shows variables, related to perception of environmental issues, which changed between the two surveys. We can see that beside the opinion about Port of Koper impacts, the priorities in development, value structure in the society, perception of environmental quality in coastal zone and readiness for participation in environmental protection changed between 2001-2003, which shows that we cannot be certain of the cause for changes of opinions in time, since they changed on more levels. As stated in the section 4.8 we did not explicitly control changes due to acquisition of additional knowledge about environmental issues or changes of attitude toward environmental protection due to economic, political, social and global changes in the society.

In this view we cannot be certain, that our results, which do show changes over time in the perception of Port's environmental impacts, can be assigned only to environmental information provided in the EIA process.

8. RECOMMENDATIONS

8.1 Recommendations for public involvement

A public consultation process should seek to reach agreement among all stakeholders and aim to identify key issues of concern and to facilitate a debate on these. An independent channel of communication between public stakeholder groups and those responsible for project completion, facilitated in a fair and open manner should be provided in an EIA process. The public demand to be involved in decision-making will continue to increase and organizations need to learn that if it is well organized, open and honest, public involvement can be more than just a means to an end. It can create a permanent dialogue that will ultimately improve the quality of decisions to the benefit of both - the organization and the public.

Both main groups involved in our research - general population and employees, express the highest trust in expert information while they rank the effectiveness of the public presentation in EIA process relatively low. They also identified TV reports as most effective. This means the provision of information could be made more effective by including TV reporting of environmental impact statements as part of the process.

We were only interested in information provided in the EIA process and not in the process itself. But if one would wish to ascertain a higher level of public involvement, changes in the EIA process should be made starting from the very beginning of the planning process. Projects or programmes can have significant impacts on the local population, but there may be divergence between general and so-called national economic interests and those of the local population. Therefore public participation in the planning process is essential for a successful outcome.

Recommendation, extracted from this research are:

- More time should be dedicated to the public involvement in order to inform and prepare the public for cooperation in the process in advance;
- There is a need for the project – willingness to participate in the planning process;
- The need for development of efficient tools and methods for public involvement;
- More financial resources should be dedicated for public involvement;
- Improved access of public to expert information.
- Information dissemination can be achieved by using a number of mechanisms including the media, in particular TV, newspapers and radio, posters and leaflets.

From the experience and broad literature available we also identified generic steps, such as:

- The purpose of an EIA is to improve the performance of projects – forum should be provided for directly or indirectly affected people for checking that they have been adequately consulted and their views taken into account in the project preparation. Without such consultation, legitimate issues may not be heard, leading to conflict and eventually to worse solutions;
- The value of environmental amenities is not absolute and finding consensus is one way of establishing values; public consultation will reveal new information, improve understanding and enable better choices to be made.
- The community should be actively involved in environmental matters in early stages, before a development proposal is fully defined; only at this early stage feedback would have the maximum influence.
- Relevant NGOs should be identified and their experience and technical capacity put to good use.
- In addition to open public meeting, techniques like surveys, workshops, small group meetings and interviews with key groups and individuals should be considered.
- The EIA process must be seen to be fair.
- The team responsible for planning and carrying out the EIA should include a sociology expert, which should be responsible for designing a strategy for public participation/consultation addressing, *inter alia*, ways and means for disseminating information, the most effective combination of consultation techniques to be used, the way these techniques are used and the timing of activities.

8.2 Future work

Further research in this area should cover in more detail contribution of social factors (partition between social and physical) to influence of public opinion and perception of environmental issues. More research is needed in investigating the complexity of the problem with a view to exploring further possible mechanisms that influence the trustworthiness and acceptability of environmental information in the society. The most effective ways of information presentation will need to be addressed.

Making a comparison of several different ports in different environmental settings could bring additional information and understanding. The following ports are of a specific interest:

- The Port in Haifa, Israel, which deals with similar problems as does the Port of Koper;
- The Port of Rotterdam, which is one of the biggest and technologically the most advanced ports in this part of Europe;
- The Port of Varna, which is far less developed and located in a country in transition.

9. CONCLUSION

We tested two primary null hypotheses:

- (i) *Public opinion does not change significantly after presentation of scientifically obtained environmental data in the EIA process regarding an industrial activity, since they have their own values, beliefs and expectations connected with it.*
- (ii) *Economic dependence on a certain technological activity (institutional constraint) does not influence public perception of environmental issues.*

In order to test the first hypothesis, we were interested in changes in opinions over time, which would show possible impacts of information, provided in EIA process. We noticed two types of changes in general population group. The first is that they grade the Port's impacts higher in relation to other pollution sources, the second is that they graded the impacts significantly lower after the EIA process. We recognised that changes in opinions over time can not be assigned to information provided in EIA process only. They could also be related to social, political, economic or even global changes in the society in the period 2001-2003, especially because respondents graded the effectiveness of the whole EIA process as low in terms of information provision and because we also detected changes of the priorities in development, value structure in the society, perception of environmental quality in coastal zone and readiness for participation in environmental protection in the same period.

In the second hypothesis we were interested in the influence of the institutional constraint and we can conclude that institutional constraint does in fact influence perception of environmental issues. This is based on the differences in perception between the general population and employees about the environmental impact of the Port of Koper, where employees of the Port grade its environmental impacts significantly lower than the general population on all issues in both surveys. Greater tolerance of the Ports' activity by employees is attributable to their familiarity, better understanding of the Ports' environmental impacts and the expected benefits from the activity. The general population and employees agree on the importance of pollution sources in the area. We also found that perceptions of environmental impacts relate especially to group gender structure and residency of respondents.

In order to investigate if the general population and employees share the same values and ethical views, respondents opinions about their priority values, trust in technological development, their feeling of moral responsibility toward environment and their readiness to participate in environmental protection were analysed. Results are similar for both main groups and show, that a stable economy is the primary societal goal in the Slovene coastal zone, which must be realised before people begin to concern themselves about environmental protection. In addition, the coastal community is ready to cooperate in environmental protection actions such as separate waste collection, but they are not in favour of making major life-style changes, although they are aware of the need to do that. Results have changed for the priorities in development, value structure in the society, perception of environmental quality in coastal zone and readiness for participation in environmental protection between 2001-2003. We detected a significant reduction in the perceived need for a stable economy and an increase in the desire for a humane society and greater freedom of speech. Our results show, that individual characteristics (age and education) influence the willingness of the people to participate in environmental protection. We can conclude that the enhancement of environmental protection in society is achievable only through a combination of a stable economic condition, the organisation of waste collection, recycling, support of low energy consumption and other state-led programs.

10 REFERENCES

1. Atkinson, R.C., Smith, E.E., Bem, D.J., Nolen.Koeksema, S., Hilgard, E., Atkinson, R.L. (1996). *Hilgard's Introduction to Psychology: Harcourt College Pub.* Academic Book Services, GA. p. 776
2. Alhakami, A., and Slovic, P. (1994). A psychological study of the inverse relationship between perceived risk and perceived benefit. *Risk Analysis*, 14(6), p. 1085-1096.
3. Ašanin Gole, P. (1999). Strateško načrtovanje odnosov z javnostmi (Strategic planning of public relationships). *Teorija in praksa (Theory and practice)*, 36, 4/1999, p. 544-557.
4. Balaban, J. (1998). *Razvojni projekt Koper 2020*. (Development project Koper 2020), Koper: Mestna občina, p. 221.
5. Bartol, B., Golobič, M., Kavčič, I., Logar, J., Marušič, I., Mlakar, A., Simonič, T. (1998). Anketno ocenjevanje kot način pridobivanja meril v postopku prostorskega planiranja. (The public poll inquire used to obtain the criteria for planning different land uses). *Urbani izziv*, 9, no. 2, p. 99-103.
6. Bechtel, R.B. (1997). *Environment and Behaviour*. SAGE Publications, London, p. 679.
7. Black, T.R. (1999): *Doing quantitative research in the social sciences : an integrated approach to research design, measurement and statistics*. London: Sage. P. 751
8. Bohnenblust, H., Slovic, P. (1998), Integrating technical analysis and public values in risk-based decision making, *Reliability Engineering and System safety*, 59, p. 151-159.
9. Bromley, D.W. (1999). Tenure Regimes and Sustainable Resource Management, in *Tenure and Sustainable Use* ed. by James Oglethorpe, Gland, Switzerland, International Union for the Conservation of Nature, pp. 79-87.
10. Canter L.W. (1996): *Environmental Impact Assessment*. McGraw Hill, NY. pp. 587-620.
11. Carmine, E.G., and Zeller, R.A. (1985). *Reliability and Validity Assessment*. Sage University Papers, Beverly Hills, London.
12. Cassidy, T. (1997). *Environmental Psychology, behaviour and Experience in Context*. Psychology Press, Hove, UK.
13. Cvetkovich, G., and Lofstedt, R. (1999). *Social trust and the management of risk*. London: Earthscan.
14. Drevenšek, M. (2002). O socioloških izhodiščih okoljskih odnosov z javnostmi. *Teorija in praksa (Theory and practice)*, 39, 5/2002, p. 827-838.
15. Dunlap, R. E. and Catton, W. Jr. (1979). Environmental sociology. *Annual Review of Sociology*, 5, p. 243-73.
16. Dunlap, R. E. and Catton, W. Jr. (1994). Struggling with human exemptionalism: The rise, decline, and revitalization of environmental sociology. *The American Sociologist*, 25(1), pp. 5-30.
17. Dunlap, R.E. (1995). Public Opinion and Environmental Policy. *Environmental Politics and Policy: Theories and evidence*, pp. 63-114, Duke University Press, Durham, NC.
18. Dunlap, R.E., Michaels, W., (2002). *Handbook of Environmental Sociology*. Greenwood Press, London, pp. 1-30
19. Earle, T. C., and Cvetkovich, G. T. (1995). *Social Trust: Toward a Cosmopolitan Society*. Praeger Publishers. 240 p.
20. Ecolas N.V. (2003): *National Oil and Chemical Spill Contingency Plan for Slovenia (NOCSCP): Risk assessment*. Co-operation Project Slovenia - Flemish Government (SLO/002/03), Antwerpen, 2004. p 41.
21. EEIONET, SORS: European Environmental Information Observation Network Database, Data from: SORS, Census 1931, 1947, 1951, 1961, 1971, 1981, 1991 *World Population Prospects, 1996 revision, UN, Population division;
22. ES, 2003: *Environment in Slovenia 2002*. Ministry of the Environment, Spatial Planning and Energy, Annual report for 2002, Ljubljana, 2003.
23. Farrow R.S., Goldberg C.B., Small M.J. (2000). Economic Valuation of the Environment: A Special Issue, *Environmental Science and Technology*, vol. 34, no. 8., 2000: pp 1318-1383.
24. Fischhoff, B. (2000). Informed Consents for Eliciting Environmental Values. *Environmental Science and Technology*, vol. 34, no. 8., 2000: pp 1439-1444.

25. Frewer, L. (1999). Risk Perception, Social Trust and Public Participation in strategic Decision Making: Implications for Emerging Technologies. Royal Swedish Academy of Sciences, *Ambio* Vol. 28 No 6. Sept. 1999, pp. 569-574.
26. Gibson, J.J. (1997): 'The ecological approach to visual perception', Houghton Mifflin, Boston.
27. Gregory, R., Slovic, P., Flynn, J. (1996). Risk perceptions, stigma and health policy. *Health Place* 2, pp. 213-220.
28. Igličar, A. (2000). Public Opinion as one Aspect of the General Legal Culture. *Javna uprava*, year 36, no. 2/2000, pg. 177-190
29. Inglehart (1997). *Modernisation and Postmodernisation: Cultural, Economical and Political Change in 43 Societies*. Princeton University Press.
30. IOS, 1998: Institute of Occupational Safety - Centre for ecology, toxicology and radiation protection. Report on monitoring results of Port of Koper impacts on noise and air pollution. Ljubljana, 1998.
31. IOS, 2000: Institute of Occupational Safety - Centre for ecology, toxicology and radiation protection. Report on monitoring results of Port of Koper impacts on noise and air pollution. Ljubljana, 2000.
32. IOS, 2001: Institute of Occupational Safety - Centre for ecology, toxicology and radiation protection. Report on monitoring results of Port of Koper impacts on noise and air pollution. Ljubljana, 2001.
33. Irwin, A. (1995). *Citizen Science - A study of respondents, expertise and sustainable development*, Routledge, New York.
34. Jameson, D. (2001). A Companion to Environmental Philosophy'. Blackwell Companions to Philosophy, Blackwell Publishers Ltd 2001, Oxford, UK.
35. Jonas, H. (1979). *The imperative of responsibility : in search of an ethics for the technological age*. Chicago, London : University of Chicago Press, 1984.
36. Keuc, A. (2000). *Presoja vplivov na okolje. Mehanizem udeležbe javnosti v procesih okoljskega odločanja*. (Environmental Impact Assessment: Mechanism of public participation in environmental decision making process), Ljubljana, Umanotera.
37. Kontic B., Gerbec M, Briggs D. (2002). *Uncertainty in the application of GIS for predictive health risk assessment for a radioactive waste repository in Slovenia*. From: for Emergency Preparedness and Health Risk Reduction, IV. Earth and Environmental Sciences, Vol 11. Kluwer Academic Pub., Netherlands. pp. 77-97.
38. Kos D., (1993). *Racionalnost neformalnih prostorov*. (Rationality of informal space). Znanstvena knjižnica FDV, Grif & Pika, Ljubljana.
39. Kos D, (2002). *Praktična sociologija za načrtovalce in urejevalce prostora*. (Practical sociology), Znanstvena knjižnica FDV, Grif & Pika, Ljubljana. pp.168
40. Korzybski, A. (1958). *Science and sanity: An introduction to non-Aristotelian systems and general semantics*. Lakerville, CT: Institute of General Semantics.
41. Kunreuther, H. and Slovic, P. (1994). Science, Values and Risk. *Annals of the American Academy of political and social Science*, p 116 -, Philadelphia.
42. Laffoley, D.d'A., Maltby, E., Vincent, M.A., Mee, L., Dunn, E., Gilliland, P., Hamer, J.P., Mortimer, D., Pound, D. (2004). The Ecosystem Approach. Coherent actions for marine and coastal environments. A report to the UK Government. Peterborough, English Nature. 65 pp.
43. Lewin, K. (1951). *Field theory in social science; selected theoretical papers*. D. Cartwright (Ed.). New York: Harper & Row, p.240.
44. MARPOL: International convention for the Prevention of Pollution from Ships; ANNEX III of MARPOL: Regulation for the Prevention of Pollution by Harmfull Substances Carried by Sea in Packaged form.
45. Mayo, D.G. and Hollander, R.D. (1994). *Acceptable evidence – Science and Values in Risk Managemet*. Oxford : Oxford University Press.
46. Mlinar, Z., (1998). Residential environment and socio-spatial change - Sociological aspects of the spatial organisation in the Koper municipality; *Annales* 12/98, pp. 61-78.
47. NEAP (1999) - National Environmental Action Program, Ministry of the Environment and Spatial Planning, Administration for the Protection of Nature.
48. NEIA ser U.,1976: 'Cognition and reality: Principles and implications of cognitive psychology, W.H.Freeman, San Francisco.
49. NIB 1997-2001. National institute for biology, Marine biology station Piran. Research on marine water quality and pollution. Annual reports, Ljubljana, 1997-2001.

50. Orlando Bonaca, M. (2001), 'A survey of the introduced alien species in the Northern Adriatic Sea', *Annales* 25/01, Koper. p. 149-158.
51. Ortolano L. (1997): *Environmental Regulation and Impact Assessment*. John Willey & Sons, Inc. NY. pp. 402-417.
52. Ošljaj, B. (2000). 'Človek in narava – Osnove diaforične etike narave' (Human and nature – The basics of diaphorical ethics of nature), Ljubljana: Znanstveno in publicistično središče.
53. Pek Drupal, D., Kos, D., (1999). Komunikacijski vidiki posegov v okolje - pomen analize socialnega okolja'; (Communication aspects of interventions in the environment – significance of social environment analysis). *Teorija in praksa (Theory and practice)*, 36, no. 4. p. 576-591.
54. Polič, M. (1999). Mestno okolje, njegove nevarnosti in človeško vedenje = The urban environment, its hazards and human behaviour. *Urbani izziv*, 10, 1, 1-14, pp. 107-113.
55. Polič, M., Dekleva, B., Marjanovič L. and Umek, P., (1981). Pomenske in vedenjske značilnosti različnih okolij (Meaning and behavioural characteristics of different environments), *Anthropos*, IV-VI, pp. 207-217.
56. REP 2003. Report on environmental quality in Koper Municipality, Koper Municipality, Annual report 2002, Koper 2003.
57. REP 1999. Institute of national health Celje. Monitoring of air quality in Koper Municipality. Report 1999, Celje, 1999.
58. REP 2003. Report on environmental quality in Koper Municipality, Koper Municipality, Annual report 2002, Koper 2003.
59. REP 1999. Institute of national health Celje. Monitoring of air quality in Koper Municipality. Report 1999, Celje, 1999.
60. Rus, A., (1990). Socio-ekonomske značilnosti koprškega Primorja ter možnosti za razvoj njegovega zaledja (Socio-economic features of Koper region and possibilities for development of its surrounding), Portorož, *15.th conference of Slovene geographers*, pp. 119-123.
61. Sagoff, M. (2000). Environmental Economics and the Conflation of Value and Benefit. *Environmental Science & Technology*, vol. 34, no. 8., 2000: pp 1426-1432.
62. SFNC, (2002). Slovenia's First National Communication under The UN Framework Convention on Climate Change, Ministry of the Environment, Spatial Planning and Energy, July 2002.
63. Skinner, B.F. (1953), *Science and Human Behaviour*, New York : Macmillan.
64. Slovic, P. (1992). Perceptions of risk: Reflections on the psychometric paradigm. *Social Theories of Risk*, Golding D. and Krimsky S., Greenwood, Westport, Connecticut, pp. 117-152.
65. Slovic, P. (1993). Perceived Risk, Trust and Democracy. *Risk analysis*, 13:675-82.
66. Slovic, P., Bohnenblust, H. (1998). Integrating technical analysis and public values in risk-based decision making. *Reliability Engineering and System safety*, pp. 151-159.
67. Slovic, P., Krauss N.N. Lappe, H. and Major, M. (1991). Risk perception of prescription drugs. Report on survey in Canada, *Can. J. Public Health* 82, pp. 15-20.
68. SORS: Statistical Office of the Republik of Slovenia: Statistical Yearbook, data by the Central Register of Population of the RS on the 31st of Decembre 1992, 1993, 1994, 1995, 1996, 1997, 1998, Census 1931, 1948, 1953, 1961, 1971, 1981, 1991, 'Population aged 15 and over by school attainment, age groups and sex, 2001'
69. SORS (2001). Statistical Office of the Republik of Slovenia. Statistical Yearbook, data by the Central Register of Population of the RS, Ljubljana, 2001.
70. Spes, M. et.al. (1998). *Quality of living environment in the Koper municipality*. Institute of Geography, Ljubljana.
71. Seale, C. et.al. (2004): *Social research methods: a reader*, Routledge, 2004. pp. 31-34.
72. The Bruntalnd Report, 1987: World Commission on Environment and Development, *Our Common Future*; OUP.
73. Štebe J., (1996): Resnična in navidezna dejstava o družboslovni anketi, Znanstvena knjižnica FDV, Ljubljana, p. 30)
74. The New Encyclopedia Britannica I, (1992), Knowledge in depth, Vol. 1-28, 15th edition.
75. The New Encyclopedia Britannica II, (1992), Ready reference, Vol. 1-10, 15th edition.
76. Toš, N., Mohler, P., Malnar, B. (1999). *Modern Society and Values*, A comparative Analysis based on ISSP Project. Ljubljana, Faculty of Social Sciences and ZUMA, Center for Survey Research and Methodology, Manheim.

77. Toš, N. (1993). *Ekološke sondaže (Environmental probes)*. Ljubljana: Fakulteta za družbene vede, Inštitut za družbene vede, Center for public opinion research. p. 159.
78. Toš, N., Klinar, P., Roter, Z., Markič, B., Mlinar, Z., Trampuž, C. (1997). 'Vrednote v prehodu I, Slovensko javno mnenje 1968-1990', (Values in transition). Ljubljana: Faculty of Social Sciences, Center for public opinion research. p. 840.
79. Toš, N., Klinar, P., Roter, Z., Markič, B., Mlinar, Z., Trampuž, C., Hafner-Fink, M., Kurdija, S., Malnar, B., Miheljak, V., Štebe, J., Švara, S., Uhan, S. (1999). Vrednote v prehodu II. Slovensko javno mnenje 1990-1998, Ljubljana : IDV - CJMMK, 1999. p. 939
80. Toš, N., Malnar, B., Hafner-Fink, M., Uhan, S., Kurdija, S., Miheljak, V., Štebe, J., Bernik, I. (2004). Vrednote v prehodu III. Slovensko javno mnenje 1999-2004. Ljubljana : Fakulteta za družbene vede, IDV - CJMMK, 2004. p. 641.
81. Trstenjak, A. (1984). Ekološka psihologija : problemi in perspective, Ljubljana : Gospodarski vestnik, p. 324.
82. Ule A. (2001): Logos spoznanja: osnove spoznavne teorije. (LOGOS of knowledge: Ljubljana. Znanstveno in publicistično središče. Zbirka alfa, p. 480. .
83. Vitousek, P.M., Mooney, H. A., Lubchenco, J., Melillo, J.M. (1997). Human Domination of Earth Ecosystems. *Science* 277. pp. 494-499.
84. Weigel, R., Newman, L. (1976). Increasing attitude-behavior correspondence by broadening the scope of the behavioral measure. *Journal of Personality and Social Psychology* 33, pp. 793-802.
85. White, L. (1967): 'The Historical Roots of our Ecologic Crisis', *Science* 1967, pp. 186-193.
86. Webster Comprehensive Dictionary (1992), Encyclopedic Edition, Vol. 2, J.J. Ferguson Publishing company, Chicago, pp. 935-936.
87. Windahl, S. (1981): *Communication Models for the Study of Mass Communications* Harlow, UK: Longman.

11. APPENDIX

11. APPENDIX

CONTENS

APPENDIX 1: QUESTIONNAIRE FOR THE 1 ST SURVEY	3
APPENDIX 2: QUESTIONNAIRE FOR THE 2 ND SURVEY	6
APPENDIX 3: GENERAL POPULATION AND SAMPLE PARAMETERS	10
A 3/1 GENERAL POPULATION PARAMETERS	10
A 3/1.1 Education.....	10
A 3/ 1.2 Age structure	10
A 3/ 1.3 Population growth in Coastal area and in Slovenia.....	11
A 3/1.4 Employment in coastal area and in Slovenia	11
A 3/2 SAMPLE POPULATION PARAMETERS.....	12
A 3/2.1 Education, employment and age structure	12
A 3/2.2 Different locations sample parameters	13
A 3/2.3 Comparison of 1 st and 2 nd survey sample parameters	14
APPENDIX 4: HYPOTHESIS TESTING	15
A 4/1 VARIABLE Y1 - INFORMATION SOURCES	15
A 4/ 4.1.1 Trust in sources of environmental information'.....	15
A 4/ 4.1.2 Effectiveness of information modes (EIM) which were used by Port of Koper authorities in informing public about their activities and impacts	21
A 4/ 4.1.3 Reliability of sources in informing public about Port of Koper activities and impacts	24
A 4/ 4.1.4 Effectiveness of information modes for informing public about changes in environmental quality in coastal area.....	27
A 4/ 4.1.5 Effectiveness of information modes for informing public about Port of Koper' environmental impact	29
A4/2 VARIABLE Y2: PRIORITIES IN PORT OF KOPER DEVELOPMENT	31
A4/3 VARIABLE Y3: VALUE STRUCTURE IN THE SOCIETY.....	34
A4/4 VARIABLE Y4: READINESS TO RISK MATERIAL SAFETY	39
A 4/5 VARIABLE Y5: PERCEPTION OF ENVIROMENTAL ISSUES	42
A 4/6 VARIABLE Y6: OPINION ON THE PORT OF KOPER ENVIRONMENTAL IMPACTS.....	57
A 4/7 VARIABLE Y7: MORAL RESPONSIBILITY TO ENVIRONMENT AND TRUST TECHNOLOGICAL SOLUTIONS OF ENVIRONMENTAL PROBLEMS	65
A 4/8 VARIABLE Y8: PARTICIPATION IN ENVIRONMENTAL PROTECTION	71
APPENDIX 5: CALCULATION OF CRONBACH α	80

APPENDIX 1: QUESTIONNAIRE FOR THE 1ST SURVEY

1. What is your level of education (profession)? (Please encircle the number)

- | | |
|-----------------------|-----------------------------|
| 1 = high education | 4 = no education |
| 2 = middle education | 5 = attending middle school |
| 3 = primary education | 6 = student |

2. What is your age? (Please, write on the line)

3. Are you employed? (Please, encircle the right answer)

Yes No Retired

4. According to your opinion – which of the following sources is telling the truth, when you receive some information regarding the Port of Koper? (Please, rank sources according to their importance with 1= the most important goal, 2= less important goal, 3=next less important goal, 4=next less important goal and 5=the least important goal)

- | | |
|--|---------------------------------------|
| <input type="checkbox"/> reporters | <input type="checkbox"/> experts |
| <input type="checkbox"/> Port of Koper | <input type="checkbox"/> I don't know |
| <input type="checkbox"/> NGO | <input type="checkbox"/> nobody |
| <input type="checkbox"/> government | |

5. What is the most important thing for development of the Port of Koper: (Please encircle the number)

- 1 = that it will be properly equipped, and will enable safe transportation and storage of all the cargo;
- 2 = that it will assure work for big number of workers,
- 3 = that it will not disturb tourist development of the area,
- 4 = that it will imply good pollution prevention program,
- 5 = I do not know

6. Which goal is the most important for Slovenia at the present (Please, rank sources according to their importance with 1= the most important goal, 2=a bit less important goal, down to 5=the least important goal)

- | | |
|---|---|
| <input type="checkbox"/> clean and healthy environment, | <input type="checkbox"/> humane society, |
| <input type="checkbox"/> solid economy, | <input type="checkbox"/> freedom of speech, |
| <input type="checkbox"/> economical growth, | <input type="checkbox"/> don't know; |

7. To what extent do you agree with the following statement: ' environment has to be protected even if it means less jobs in local community'? (Please, mark the number)

I agree				Don't agree
1	2	3	4	5

8. Who is the major contributor to air pollution in the coastal area: (Please rank three most important in the order of importance with 1= the most important polluter, 2=a bit less important, down to 5=the least important polluter)

- | | |
|--|---|
| <input type="checkbox"/> agriculture | <input type="checkbox"/> Port of Koper |
| <input type="checkbox"/> waste and waste sites | <input type="checkbox"/> road traffic |
| <input type="checkbox"/> industry | <input type="checkbox"/> individual fire places |
| <input type="checkbox"/> tourism | <input type="checkbox"/> I do not know |

9. Who is the major contributor to marine pollution in Slovene coastal area: (Please rank three most important in the order of importance with 1= the most important polluter, 2=a bit less important, down to 5=the least important polluter)

- | | |
|--|--|
| <input type="checkbox"/> agriculture | <input type="checkbox"/> Port of Koper |
| <input type="checkbox"/> illegal outflow from sewage to rivers and the sea | <input type="checkbox"/> road traffic |
| <input type="checkbox"/> outflow from the waste water treatment plant | <input type="checkbox"/> industry |
| <input type="checkbox"/> tourism | <input type="checkbox"/> I do not know |

10. Who is the major contributor to noise pollution in the coastal area: (Please rank three most important in the order of importance with 1= the most important polluter, 2=a bit less important, down to 5=the least important polluter)

- | | |
|--------------------------------------|--|
| <input type="checkbox"/> agriculture | <input type="checkbox"/> Port of Koper |
| <input type="checkbox"/> tourism | <input type="checkbox"/> road traffic |
| <input type="checkbox"/> industry | <input type="checkbox"/> I do not know |

11. How do you grade the risk from environmental pollution: (Please, tick one square in each line)

	High risk	Medium risk	Low risk	No threat	I don't know
a.) Air pollution	<input type="checkbox"/>	<input type="checkbox"/>	<input type="checkbox"/>	<input type="checkbox"/>	<input type="checkbox"/>
b.) Water pollution	<input type="checkbox"/>	<input type="checkbox"/>	<input type="checkbox"/>	<input type="checkbox"/>	<input type="checkbox"/>
c.) Industrial waste water	<input type="checkbox"/>	<input type="checkbox"/>	<input type="checkbox"/>	<input type="checkbox"/>	<input type="checkbox"/>
d.) Use of chemicals in food production	<input type="checkbox"/>	<input type="checkbox"/>	<input type="checkbox"/>	<input type="checkbox"/>	<input type="checkbox"/>
e.) Accidents in transportation	<input type="checkbox"/>	<input type="checkbox"/>	<input type="checkbox"/>	<input type="checkbox"/>	<input type="checkbox"/>
d.) Risk of radon in your home	<input type="checkbox"/>	<input type="checkbox"/>	<input type="checkbox"/>	<input type="checkbox"/>	<input type="checkbox"/>

12. According to your opinion, what is the major environmental impact of the Port of Koper? (Please, mark one number in each line)

	Major env. impact	1	2	3	4	No env. impact
a.) Air pollution		1	2	3	4	5
b.) Marine pollution		1	2	3	4	5
c.) Waste production		1	2	3	4	5
d.) Soil pollution.		1	2	3	4	5
e.) Noise generation		1	2	3	4	5
f.) Biological introduction of alien species		1	2	3	4	5
g.) Storage of hazardous materials		1	2	3	4	5
h.) Risk from accidents						
	Road accident	1	2	3	4	5
	Ship accident	1	2	3	4	5
	Railway accident	1	2	3	4	5

13. How strong do you agree with the following statements? (Please, mark the rectangle in each line)

	Strongly agree	Agree	Disagree	Strongly disagree	I do not know
a.) We believe too much in science and technology and too little in intuition and feelings.	<input type="checkbox"/>	<input type="checkbox"/>	<input type="checkbox"/>	<input type="checkbox"/>	<input type="checkbox"/>
b.) Modern science is causing more harm than good.	<input type="checkbox"/>	<input type="checkbox"/>	<input type="checkbox"/>	<input type="checkbox"/>	<input type="checkbox"/>
c.) Any change in environment, caused by human activity, no matter how scientifically founded, is harmful.	<input type="checkbox"/>	<input type="checkbox"/>	<input type="checkbox"/>	<input type="checkbox"/>	<input type="checkbox"/>
d.) Modern science will solve all environmental problems without us having to change our life habits.	<input type="checkbox"/>	<input type="checkbox"/>	<input type="checkbox"/>	<input type="checkbox"/>	<input type="checkbox"/>
e.) We worry too much about our future and environment and not enough about prices rates and employment at present.	<input type="checkbox"/>	<input type="checkbox"/>	<input type="checkbox"/>	<input type="checkbox"/>	<input type="checkbox"/>
f.) Nearly everything we do is harmful to the environment.	<input type="checkbox"/>	<input type="checkbox"/>	<input type="checkbox"/>	<input type="checkbox"/>	<input type="checkbox"/>
g.) People worry too much that the development of modern technological society will harm the environment.	<input type="checkbox"/>	<input type="checkbox"/>	<input type="checkbox"/>	<input type="checkbox"/>	<input type="checkbox"/>

14. Please mark to which extent you agree with the following statements: (Please encircle one number in each line)

	Yes, of course				No, not at all
a) Would you be ready to pay higher prices for goods in order to protect the environment?	1	2	3	4	5
b) Would you be ready to pay higher taxes in order to protect the environment?	1	2	3	4	5
c) Would you be ready to lower your standard of living in order to protect the environment (simple food, less tourism, smaller use of luxurious items)?	1	2	3	4	5
d) Are you collecting your waste separately?	1	2	3	4	5
e.) Would you collect your waste separately?	1	2	3	4	5
f.) Are you recycling everything that is possible to recycle?	1	2	3	4	5
g.) Are you ready to use your car less in order to protect the environment if the public transport would be available?	1	2	3	4	5
h.) Are you ready to lower your energy consumption?	1	2	3	4	5
i.) Would you be ready to pay higher prices for some products, because the Port of Koper wishes to implement better environmental protection program?	1	2	3	4	5

APPENDIX 2: QUESTIONNAIRE FOR THE 2ND SURVEY

1. What is your level of education (profession)? (Please encircle the number)

1 = high education
2 = middle education
3 = primary education

4 = no education
5 = attending middle school
6 = student

2. What is your age? (Please, write on the line)

3. Are you employed? (Please, encircle the right answer)

Yes No Retired

4. According to your opinion – which of the following sources is telling the truth, when you receive some information regarding the Port of Koper? (Please, rank sources according to their importance with 1= the most important goal, 2= less important goal, 3=next less important goal, 4=next less important goal and 5=the least important goal)

Reporters
 Port of Koper
 NGO
 government

experts
 I don't know
 Nobody

5. What is the most important thing for development of the Port of Koper: (Please encircle the number of the most important option)

1 = that it will be properly equipped, and will enable safe transportation and storage of all the cargo;
2 = that it will assure work for big number of workers,
3 = that it will not disturb tourist development of the area,
4 = that it will imply good pollution prevention program,
5 = I do not know

6. Which goal is the most important for Slovenia at the present (Please, rank sources according to their importance with 1= the most important goal, 2=a bit less important goal, down to 5=the least important goal)

clean and healthy environment,
 solid economy,
 economical growth,

humane society,
 freedom of speech,
 don't know;

7. To what extent do you agree with the following statement: ' environment has to be protected even if it means less jobs in local community'? (Please, mark the responding number)

I agree 1 2 3 4 Don't agree 5

8. Who is the major contributor to air pollution in the coastal area: (Please rank three most important in the order of importance with 1= the most important polluter, 2=a bit less important, down to 5=the least important polluter)

agriculture
 waste and waste sites
 industry
 tourism

Port of Koper
 road traffic
 individual fire places
 I do not know

9. Who is the major contributor to marine pollution in the coastal area: (Please rank three most important in the order of importance with 1= the most important polluter, 2=a bit less important, down to 5=the least important polluter)

- agriculture
- illegal outflow from sewage to rivers and the sea
- outflow from the waste water treatment plant
- tourism
- Port of Koper
- road traffic
- industry
- I do not know

10. Who is the major contributor to noise pollution in the coastal area: (Please rank three most important in the order of importance with 1= the most important polluter, 2=a bit less important, down to 5=the least important polluter)

- agriculture
- tourism
- industry
- Port of Koper
- road traffic
- I do not know

11. Which mode of information, organized by the Port of Koper was the most effective for you: (Please rank three most important in the order of importance with 1= the most important polluter, 2=a bit less important, down to 5=the least important polluter)

- TV news
- information on the internet
- newspaper articles
- radio broadcasting
- 'open door' days in the Port
- public presentations in EIA process
- none of them
- I do not know

12. According to your opinion, what is the major environmental impact of the Port of Koper? (Please, mark one number in each line)

	Major env. impact					No env. impact
	1	2	3	4	5	
a.) Air pollution	1	2	3	4	5	
b.) Marine pollution	1	2	3	4	5	
c.)Waste production	1	2	3	4	5	
d.) Soil pollution.	1	2	3	4	5	
e.) Noise generation	1	2	3	4	5	
f.) Biological introduction of alien species	1	2	3	4	5	
g.) Storage of hazardous materials	1	2	3	4	5	
h.) Risk from accidents						
Road accident	1	2	3	4	5	
Ship accident	1	2	3	4	5	
Railway accident	1	2	3	4	5	

13. How strong do you agree with the following statements? (Please, mark the rectangle in each line)

	Strongly agree	Agree	Disagree	Strongly disagree	I do not know
a.) We believe too much in science and technology and too little in intuition and feelings.	<input type="checkbox"/>	<input type="checkbox"/>	<input type="checkbox"/>	<input type="checkbox"/>	<input type="checkbox"/>
b.) Modern science is causing more harm than good.	<input type="checkbox"/>	<input type="checkbox"/>	<input type="checkbox"/>	<input type="checkbox"/>	<input type="checkbox"/>
c.) Any change in environment, caused by human activity, no matter how scientifically founded, is harmful.	<input type="checkbox"/>	<input type="checkbox"/>	<input type="checkbox"/>	<input type="checkbox"/>	<input type="checkbox"/>
d.) Modern science will solve all environmental problems without us having to change our life habits.	<input type="checkbox"/>	<input type="checkbox"/>	<input type="checkbox"/>	<input type="checkbox"/>	<input type="checkbox"/>
e.) We worry too much about our future and environment and not enough about prices rates and employment at present.	<input type="checkbox"/>	<input type="checkbox"/>	<input type="checkbox"/>	<input type="checkbox"/>	<input type="checkbox"/>
f.) Nearly everything we do is harmful to the environment.	<input type="checkbox"/>	<input type="checkbox"/>	<input type="checkbox"/>	<input type="checkbox"/>	<input type="checkbox"/>
g.) People worry too much that the development of modern technological society will harm the environment.	<input type="checkbox"/>	<input type="checkbox"/>	<input type="checkbox"/>	<input type="checkbox"/>	<input type="checkbox"/>

14. Which source of information you consider the most reliable in informing public about Port of Koper activities and impacts: (Please rank three most important in the order of importance with 1= the most important polluter, 2=a bit less important, down to 5=the least important polluter)

- | | |
|---|--|
| <input type="checkbox"/> Newspaper and TV reporters | <input type="checkbox"/> Experts |
| <input type="checkbox"/> Port of Koper | <input type="checkbox"/> Rumours, gossip.... |
| <input type="checkbox"/> NGO | <input type="checkbox"/> I do not know |
| <input type="checkbox"/> Government | <input type="checkbox"/> None of them |

15. Please mark to which extent you agree with the following statements: (Please encircle one number in each line)

	Yes, of course	1	2	3	4	No, not at all
a) Would you be ready to pay higher prices for goods in order to protect the environment?	1	2	3	4	5	
b) Would you be ready to pay higher taxes in order to protect the environment?	1	2	3	4	5	
c) Would you be ready to lower your standard of living in order to protect the environment (simple food, less tourism, smaller use of luxurious items)?	1	2	3	4	5	
d) Are you collecting your waste separately?	1	2	3	4	5	
e.) Would you collect your waste separately?	1	2	3	4	5	
f.) Are you recycling everything that is possible to recycle?	1	2	3	4	5	
g.) Are you ready to use your car less in order to protect the environment if the public transport would be available?	1	2	3	4	5	
h.) Are you ready to lower your energy consumption?	1	2	3	4	5	
i.) Would you be ready to pay higher prices for some products, because the Port of Koper wishes to implement better environmental protection program?	1	2	3	4	5	

16. Which mode of information about *changes in environmental quality in coastal area* was the most effective for you: (Please rank three most important in the order of importance with 1= the most important polluter, 2=a bit less important, down to 5=the least important polluter)

- TV news
- information on the internet
- newspaper articles
- radio broadcasting
- rumours, gossip...
- public presentations organized by NGO
- public presentations in EIA process
- I do not know
- none of them

17. Which source of information about *Port of Koper' environmental impact* you consider the most reliable: (Please rank three most important in the order of importance with 1= the most important polluter, 2=a bit less important, down to 5=the least important polluter)

- TV news
- information on the internet
- newspaper articles
- radio broadcasting
- rumours, gossip...
- public presentations organized by NGO
- public presentations in EIA process
- I do not know
- none of them

18. How do you grade the risk to human health from environmental pollution: (Please, tick one square in each line)

	High risk	Medium risk	Low risk	No threat	I don't know
a.) Air pollution	<input type="checkbox"/>	<input type="checkbox"/>	<input type="checkbox"/>	<input type="checkbox"/>	<input type="checkbox"/>
b.) Water pollution	<input type="checkbox"/>	<input type="checkbox"/>	<input type="checkbox"/>	<input type="checkbox"/>	<input type="checkbox"/>
c.) Industrial waste water	<input type="checkbox"/>	<input type="checkbox"/>	<input type="checkbox"/>	<input type="checkbox"/>	<input type="checkbox"/>
d.) Use of chemicals in food production	<input type="checkbox"/>	<input type="checkbox"/>	<input type="checkbox"/>	<input type="checkbox"/>	<input type="checkbox"/>
e.) Accidents in transportation	<input type="checkbox"/>	<input type="checkbox"/>	<input type="checkbox"/>	<input type="checkbox"/>	<input type="checkbox"/>
d.) Risk of radon in your home	<input type="checkbox"/>	<input type="checkbox"/>	<input type="checkbox"/>	<input type="checkbox"/>	<input type="checkbox"/>

APPENDIX 3: GENERAL POPULATION AND SAMPLE PARAMETERS

A 3/1 GENERAL POPULATION PARAMETERS

A 3/1.1 Education

Table A 3/ 1

Percentage table - Comparison of Slovene population to residents of selected locations according to education – 1st survey

	N	No schooling	Primary school	Upper secondary schools	Non-university colleges	University	Unknown
Ankaran	50	0,15	0,22	0,44	0,09	0,07	0,03
Bertoki	37	0,29	0,18	0,44	0,05	0,03	0,01
Hrvatini	25	0,23	0,23	0,45	0,04	0,02	0,03
Koper	109	0,14	0,23	0,47	0,08	0,07	0,01
Port of Koper	33						
Sp Skofije	16	0,20	0,25	0,45	0,06	0,04	0,00
Zg Skofije	22	0,26	0,29	0,38	0,04	0,02	0,01
RSI population		0,17	0,30	0,43	0,05	0,04	0,01

Source: SORS, Population aged 15 and over by school attainment, age groups and sex, 2001, Source: Labour Force Survey

A 3/ 1.2 Age structure

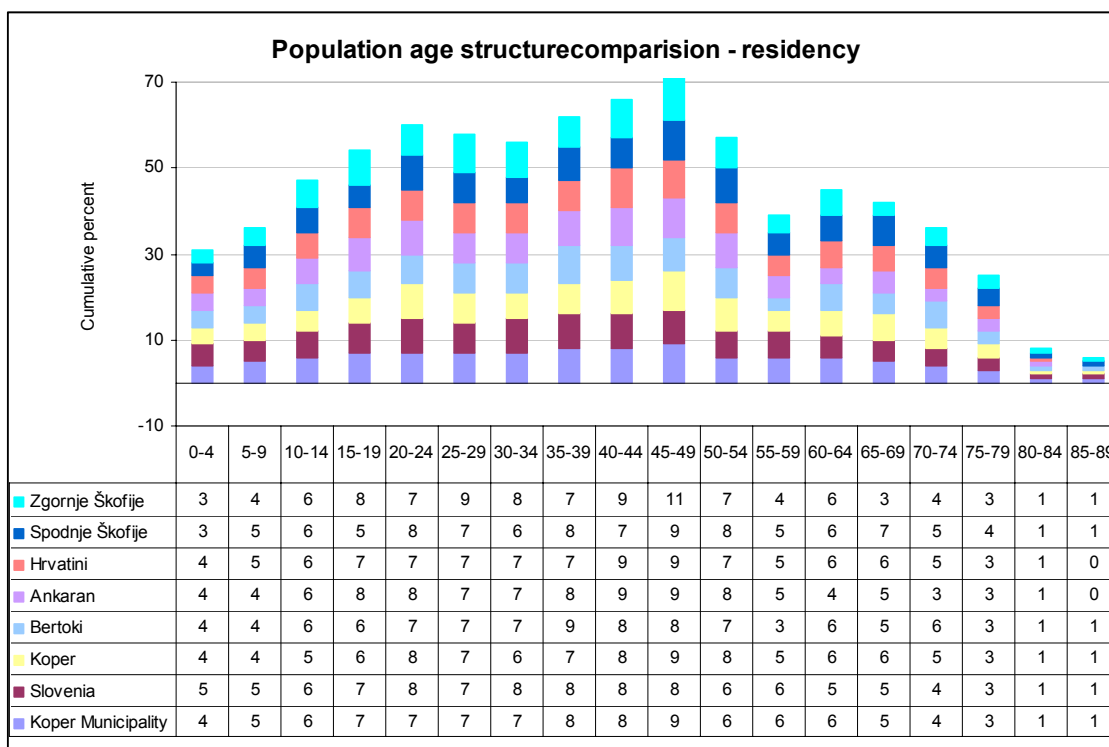

Source: SORS, Population aged 15 and over by school attainment, age groups and sex, 2001, Source: Labour Force Survey

Graph A3/ 1: Percentage table - Comparison of Slovene population to residents of selected locations according to age 2001

A 3/ 1.3 Population growth in Coastal area and in Slovenia

Table A 3/ 2
Comparison of population growth

Years	Population growth rate in coastal area (Koper, Izola, Piran)	Population in coastal area	Population growth rate in Slovenia	Population in Slovenia
	%	Number	%	Number
1931	-	56.792	-	-
1948	-0,5	52.550	-	1.439.800
1953	-4,1	42.665	0,9	1.504.427
1961	2,0	49.977	0,7	1.591.523
1971	1,6	58.292	0,8	1.727.137
1981	1,8	69.591	0,9	1.891.864
1991	0,9	76.343	0,4	1.974.839
1992	-	77.938	-	1.994.084
1993	0,1	77.983	-0,2	1.989.408
1994	0,1	78.091	0,0	1.989.477
1995	0,2	78.262	-0,1	1.987.750
1996	1,6	79.507	0,0	1.986.989
1997	-0,2	79.334	-0,1	1.984.923
1998	-0,3	79.134	-0,3	1.978.334
1999	0,8	79.806	0,5	1.987.755

Source: European Environmental Information Observation Network

SORS: Census 1931, 1948, 1953, 1961, 1971, 1981, and 1991

SORS: Statistical Yearbook, data by the Central Register of Population of the RS on the 31st of December 1992, 1993, 1994, 1995, 1996, 1997, 1998

A 3/1.4 Employment in coastal area and in Slovenia

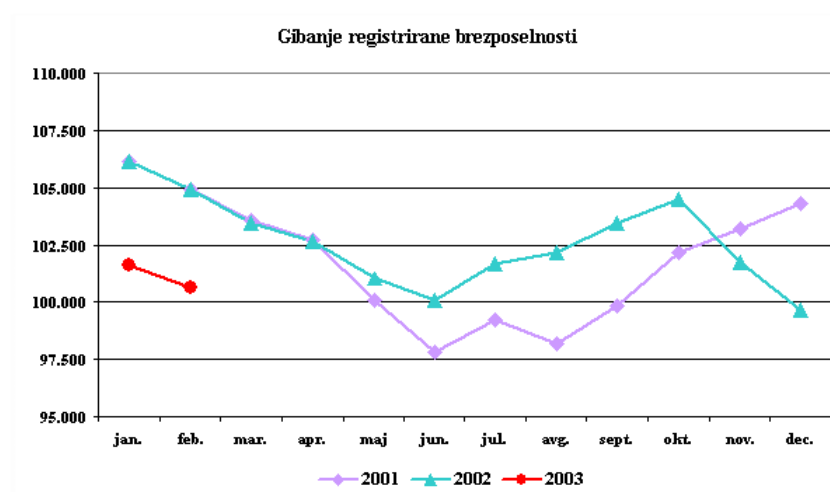

Source: Employment Service of Slovenia.

Graph A3/ 2: Seasonal changes of employment rate in years 2001-2003

Table A 3/ 3

Changes of average annual employment rate in coastal area and Slovenia in years 1992-2000

Years	Employment rate in coastal area		Employment rate in Slovenia	
	%	Number	%	Number
1992			88,5	11,5
1993			85,6	14,4
1994			85,6	14,4
1995			86,1	13,9
1996			86,1	13,9
1997	88,5	11,5	85,6	14,4
1998	89,0	11,0	85,5	14,5
1999	89,7	10,3	86,4	13,6
2000*	89,9	10,1	87,4	12,6

Source: Employment Service of Slovenia, European Environmental Information Observation Network, SORS

A 3/2 SAMPLE POPULATION PARAMETERS**A 3/2.1 Education, employment and age structure**

Table A 3/ 4

Respondents sample size / location

	1 st survey - N-2001	2 nd survey - N-2003
Ankaran	50	91
Bertoki	38	29
Hrvatini	25	33
Koper	109	125
Port of Koper	33	41
Sp Skofije	16	42
Zg Skofije	22	22
All together	293	383

Table A 3/ 5

Respondents sample size /gender, education

Gender	N		Education	N	
	2001	2003		2001	2003
Male	154	210	high	71	120
Female	139	173	medium	152	186
			primary	40	42
			none	10	10
			student	20	25
Total	293	383		293	383

Table A 3/ 6

Respondents sample size /age, employment

Age	N		Employment	N	
	2001	2003		2001	2003
18-25	40	37	employed	168	191
26-35	52	63	unemployed	32	58
36-45	67	82	retired	73	109
46-55	63	81	student	20	25
56-65	30	62			
66-75	30	39			
76-	11	19			
Total	293	383		293	383

A 3/2.2 Different locations sample parameters

1st survey results analysis

Table A 3/ 7

Sample education structure (percentage)

	Ankaran (%)	Bertoki (%)	Hrvatini (%)	Koper (%)	Port (%)	Sp Skofije (%)	Zg Skofije (%)	All together (%)
high	36,0	15,8	12,0	24,8	9,1	43,8	9,1	22,5
medium	40,0	57,9	56,0	52,3	57,6	25,0	72,7	51,9
primary	6,0	13,2	12,0	14,7	27,3	6,3	13,6	13,7
none	2,0	0,0	4,0	4,6	6,1	6,3	0,0	3,4
m-student	2,0	5,3	8,0	0,0	0,0	6,3	4,5	2,4
u-student	14,0	7,9	8,0	3,7	0,0	12,5	0,0	6,1

Table A 3/ 8

Sample employment structure (percentage)

	Ankaran (%)	Bertoki (%)	Hrvatini (%)	Koper (%)	Port (%)	Sp Skofije (%)	Zg Skofije (%)	All together (%)
employed	54,0	47,4	60,0	49,5	97,0	50,0	57,1	57,2
non employed	16,0	7,9	24,0	11,9	0,0	25,0	23,8	11,0
retired	26,0	26,3	16,0	33,9	3,0	25,0	19,0	25,0
student	4,0	18,4	0,0	4,6	0,0	0,0	0,0	6,8

Table A 3/ 9

Sample age structure (percentage)

	Ankaran (%)	Bertoki (%)	Hrvatini (%)	Koper (%)	Port (%)	Sp Skofije (%)	Zg Skofije (%)	All together (%)
18-25	12,0	18,4	20,0	9,2	9,1	31,3	36,4	13,7
26-35	22,0	21,1	20,0	14,7	57,6	18,8	18,2	17,7
36-45	22,0	18,4	24,0	20,2	27,3	12,5	27,3	22,9
46-55	18,0	21,1	28,0	20,2	6,1	6,3	4,5	21,5
56-65	8,0	10,5	4,0	14,7	0,0	12,5	9,1	10,2
66-75	12,0	10,5	4,0	14,7	0,0	18,8	0,0	10,2
76-	6,0			6,4	0,0		4,5	3,8

Table A 3/ 10

Sample age structure (percentage)

	Ankaran (%)	Bertoki (%)	Hrvatini (%)	Koper (%)	Port (%)	Sp Skofije (%)	Zg Skofije (%)	All together (%)
Female	58,0	47,4	48,0	40,5	12,1	50,1	59,1	47,4
Male	42,0	52,6	52,0	49,5	87,9	50,0	40,9	52,6

A 3/2.3 Comparison of 1st and 2nd survey sample parameters

Comparison of respondent's age, gender employment and education structure, comparing respondents from general population and group of employees in Percentage tables.

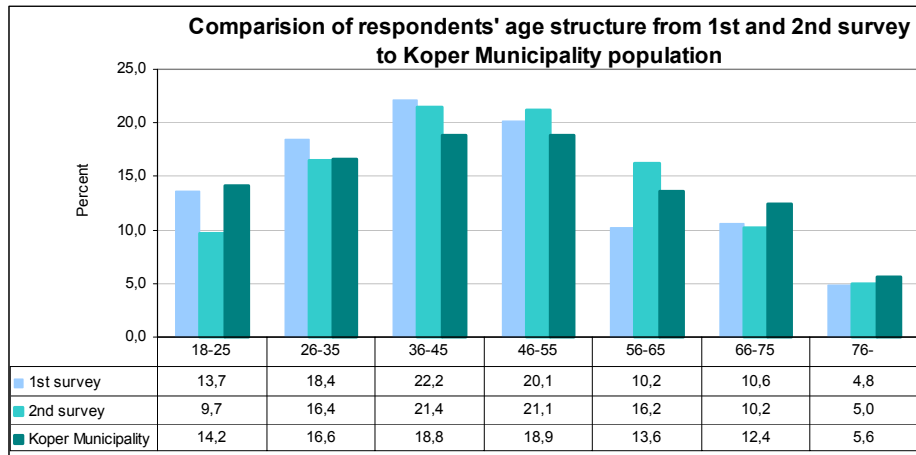

Graph A3/ 3: Age structure of respondents – comparison of age structure in both surveys

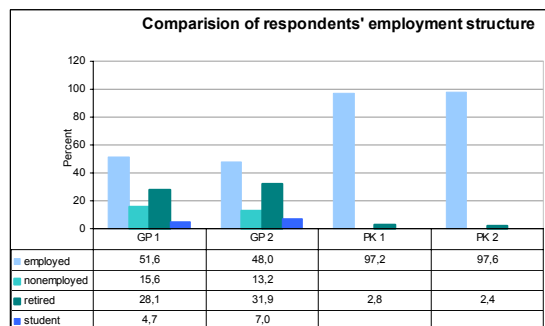
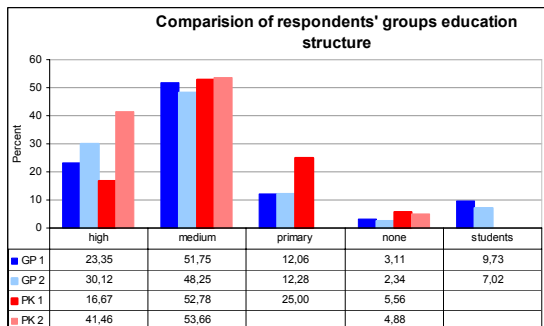
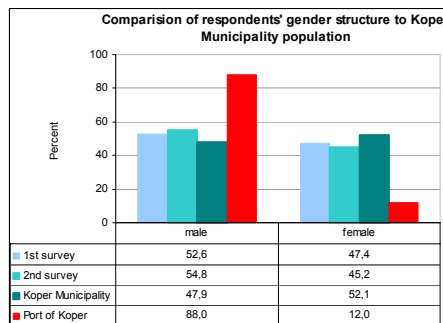

GP1 – general population (residents in surrounding of Port of Koper) – in 1st survey
 GP2 – general population (residents in surrounding of Port of Koper) – in 2nd survey
 PK1 – employees of the Port of Koper – 1st survey
 PK2 – employees of the Port of Koper – 2nd survey

Graph A3/ 4: Sample parameters comparison for both surveys

APPENDIX 4: HYPOTHESIS TESTING

A 4/1 VARIABLE Y1 - INFORMATION SOURCES

A 4/ 4.1.1 Trust in sources of environmental information'

Question Q4 requires respondents to rank from 1 to 5 their trust in environmental information provided by Reporters, Port of Koper authorities (PK), Non-governmental organization (NGO), Government, experts or no one.

1st survey

General result for the 'Trust in sources of information' is the following:

Descriptive Statistics				
	N	Mean	Std. Deviation	
Reporters	252	3,38	1,204	
Port of Koper	252	2,73	1,295	
NGO	252	2,78	1,254	
Government	252	1,89	1,064	
Experts	252	4,19	1,053	
Valid N (listwise)	252			

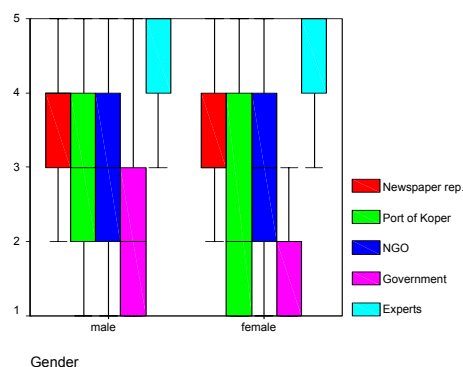

Graph A4/ 1: Trust in sources of information – descriptive data of the 1st survey results (N=274)

Friedman test shows, that respondents show significantly different level of trust in different sources of information ($\chi^2=297,044$, sig. = 0,00, df=6).

According to 52% of respondents, experts are considered as the most trusted source of information, with the mean 4,19. (Rank 1-5). If the influence of location of residency on the opinion is investigated, we find the highest level of trust in expert information in Sp. Škofije (mean=4,6) and in Ankaran (mean = 4,4) and the lowest in Bertoki (mean=3,8). (Low trust in expert information in Bertoki could be attributed to the long fight of their community for the closure or any action for improvement in a chemical factory, located in the area. Respondents in Bertoki were very active in the negotiations and had a negative experience with the factory.) Friedman test shows significant difference in trust in expert information according to location ($\chi^2=18,541$, sig. = 0,005, df=6).

Investigation of the influence of education on opinion shows significant correlation in City of Koper, where respondents with high and medium education and university students show higher level of trust in expert information than respondents with primary or no education (Spearman's $\rho = -0,213$, sig(2-tailed) = 0,039).

The second most trusted source of information are Reporters, with the mean 3,38. 21,7% of respondents graded them as the most reliable source of information. The highest result is achieved in Hrvatini and Zgornje Škofije (mean = 4) and the lowest in the Port of Koper (mean = 2,8). Spearman's ρ test shows a weak correlation among employment status and trust in Reporters information in Bertoki (Spearman's $\rho = -0,376$; sig. (2-tailed)=0,034) and among education structure and trust in Reporters information in Sp. Škofije. (Spearman's $\rho = -0,692$; sig. (2-tailed)=0,013). Friedman test shows, that the difference in opinion regarding Reporters information is not significant for different location of residency ($\chi^2=6,606$, sig. = 0,359, df=6).

Although there are many reasons for the different levels of trust in different sources of information including age structure, education level or gender, the calculation of correlation coefficient in the common group (all locations together) only shows a correlation to employment

status and trust into Reporter's information. (Spearman's $\rho = -0,19$; sig. (2-tailed)=0,002) Employed respondents (mean = 3,6) show a significantly higher level of trust in reporter's information than other groups (non-employed=3,3; retired=3,1; students=2,9).

Employees of the Port show the greatest trust in the Port of Koper's (PK) information (mean = 3,6); the lowest score in trust in the Ports information was in Bertoki (mean = 2,1). 9,5% of respondents graded the port's of information as the most reliable source.

The Government is ranked as the least trusted source of information, with a mean value of 1,89. Only 2,7% of respondents grade it as the most reliable source of information. The lowest results are from Zgoranje Škofije and the Port of Koper (1,6); the highest results are from Bertoki (2,3) and Ankaran (2,2) although Friedman test shows, that there is no significant difference in trust in Governmental information according to location of residency. ($\chi^2=12,127$, sig. = 0,059, df=6).

Trust in NGO information has a medium rank (mean=2,78). 10,9% of respondents grades NGO's as the most reliable source of information. The Friedman test shows significant difference in trust in NGO information for different locations ($\chi^2=17,632$, sig. = 0,007, df=6). Correlation among employment and trust in NGO source of information was identified in Ankaran (Spearman's $\rho=-0,321$, sig (2-tailed)=0,33) (means: employed m=3,39; unemployed m=2,0; retired m=2,45). NGO's received highest points in Bertoki (2,97) and the lowest in Koper (1,97) and Port of Koper (2,0). The Friedman test for trust in Port of Koper's information according to location shows a significant difference among them. ($\chi^2=19,14$, sig. = 0,004, df=6). Respondents in Bertoki, who display the lowest trust in expert information, show the highest level of trust in NGO information. Correlation among employment and trust in NGO information was also identified in Ankaran (Spearman's $\rho=-0,321$, sig (2-tailed)=0,33)

1st survey results:

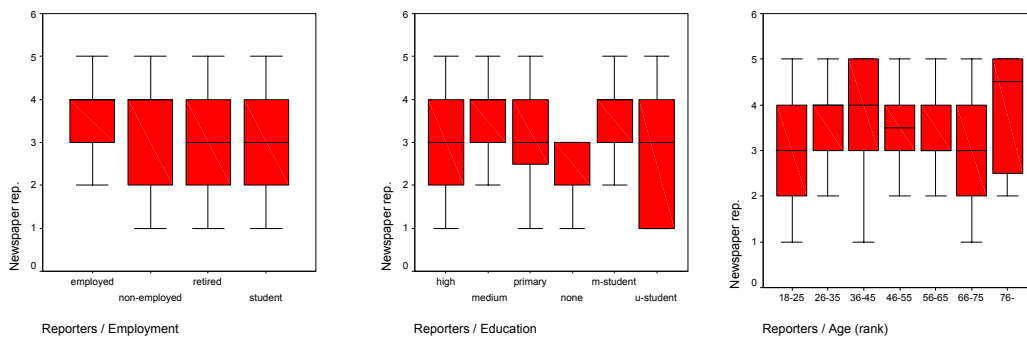

Graph A4/ 2: Opinion on reporters' information – 1st survey

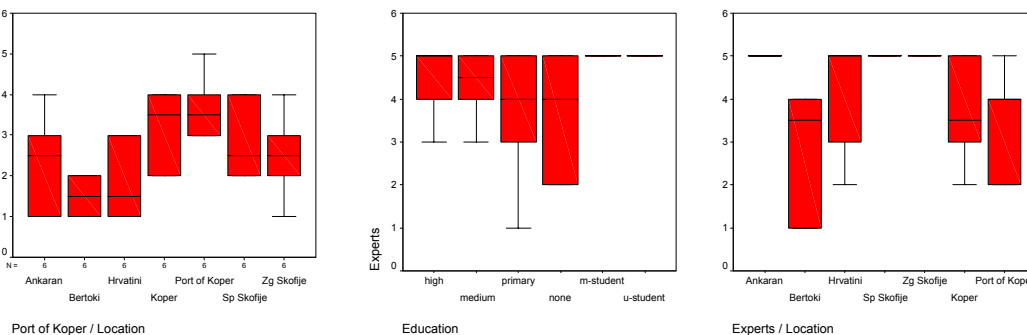

Graph A4/ 3: Opinion on Port of Koper and Expert information

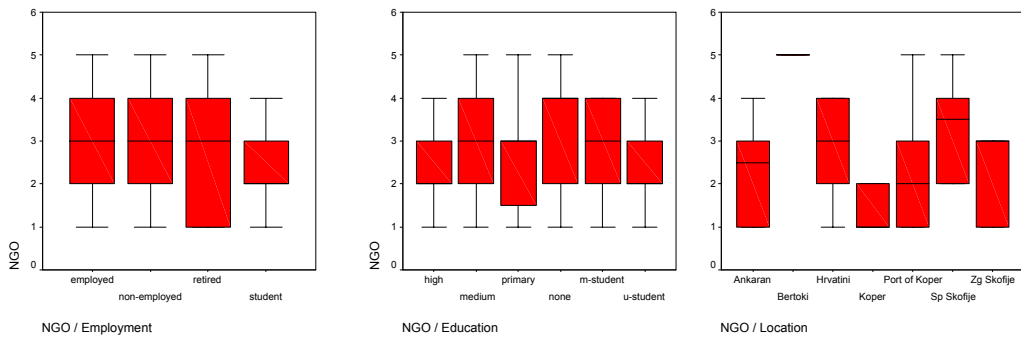

Graph A4/ 4: Opinion on NGO information

2nd survey results:

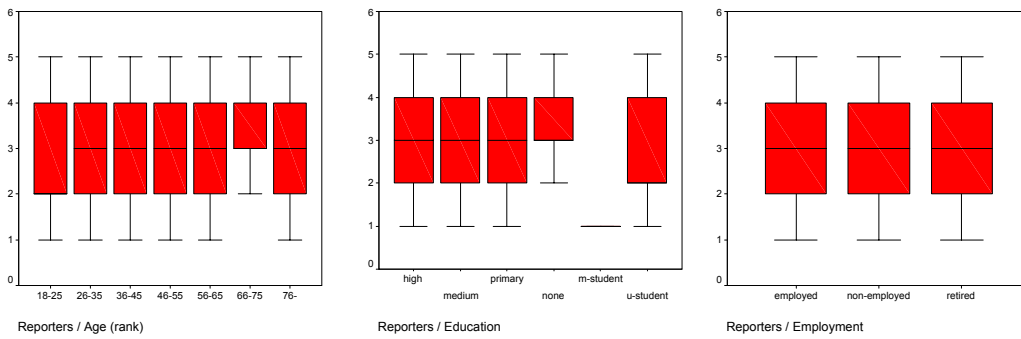

Graph A4/ 5: Opinion on reporters information – 2nd survey

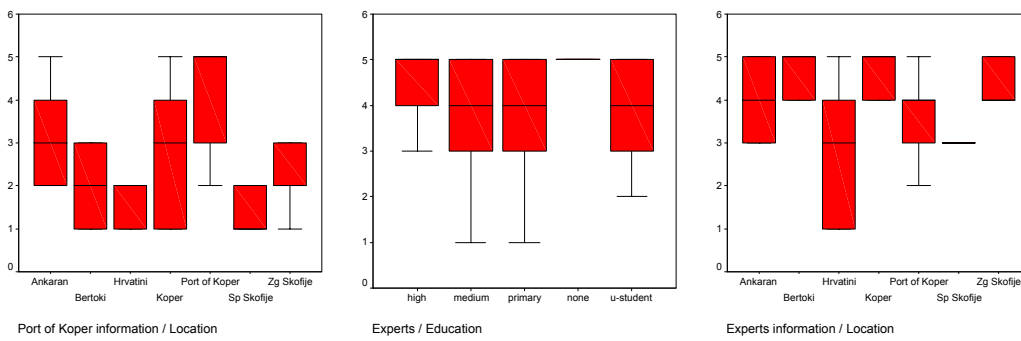

Graph A4/ 6: Opinion on Port of Koper and Expert information

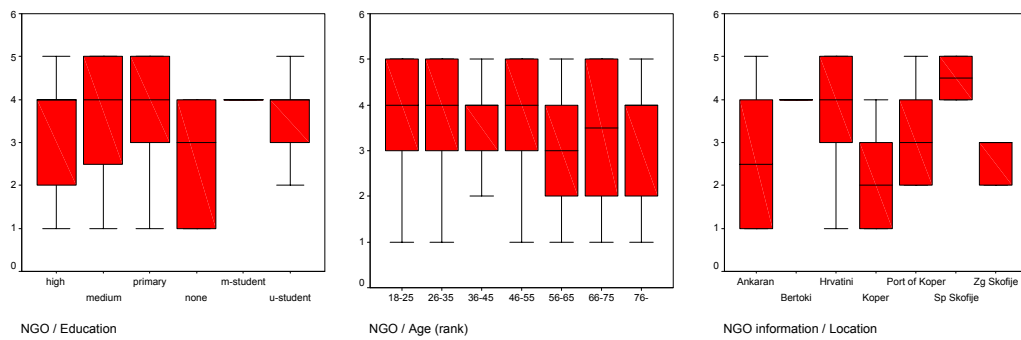

Graph A4/ 7: Opinion on NGO information

2nd survey

According to 43% of respondents, experts are considered as the most trusted source of information again, with the mean 4,02 (rank 1-5). The highest level of trust in experts is expressed in Zg. Škofije (mean=4,17), Ankaran (mean=4,16) and Koper (mean=4,11). The lowest level is expressed in Port of Koper (mean=3,72) and in Bertoki (mean=3,86), but differences among respondents' location of residency are not statistically significant.

	N	Mean	Std. Deviation
Reporters	307	2,97	1,193
Port of Koper	307	2,60	1,330
NGO	307	3,44	1,313
Government	307	1,79	,978
Experts	307	4,02	1,088

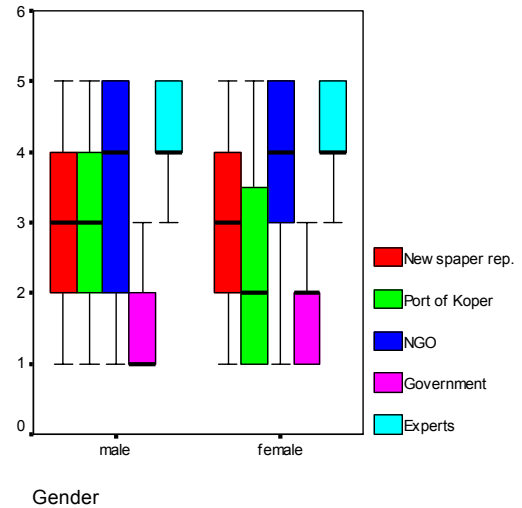

Graph A4/ 8: Trust in sources of information – descriptive data of the 2nd survey results (N=383)

The second most trusted source of information is NGO information (mean=3,44). 26% of respondents graded NGO's as the most trusted source of information. The highest level of trust is expressed in Bertoki (mean=3,77) and the lowest in respondents from Port of Koper employees (mean=3,33), but the differences are not statistically significant. There is a statistically significant correlation among education level and trust in NGO information in respondents from Port of Koper employees, where respondents with medium education (mean=3,65) express significantly higher trust than respondents with high education (mean=2,87) (Spearman's $\rho=0,371$, sig (2-tailed)=0,026).

Trust in reporters is graded as the third (mean=2,97). 11,7% of respondents ranked them as the most trusted source of information. There is correlation among age and trust in reporters, where older respondents express higher level of trust (mean=3,06-3,41) than younger respondents (mean=2,61-2,88).

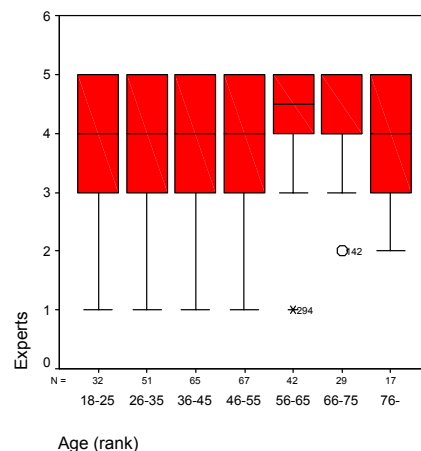

Graph A4/ 9: Trust in experts information – influence of age - 2nd survey results

Trust in Port of Koper information is graded with the mean=2,60. 11,8% of respondents ranked the Port of Koper as the most trusted source of information. 28,6% of respondents form the group of the Port's employees considers it as the most trusted source of information. The

highest trust in the Port is expressed in Hrvatini and Bertoki, the lowest in Ankaran and Koper, but differences are not statistically significant.

The least trusted source of information is the government with a mean = 1,79 and only 1,9% of respondents ranked government as the most trusted source of information. Retired respondents have the highest level of trust in the government (mean=2,37), but the difference is not statistically significant.

Results aggregation

There is no consistent influence of extraneous variables identified on respondents' opinion in the issue of trust in sources of environmental information in both surveys. Main differences occur between group of employees and group of general population in opinion about Port of Koper authorities information and about NGO information. Generally, trust in all sources of information dropped between both surveys, except for the trust in NGO information, which rose significantly. A comparison of both surveys shows that in the first survey 7,5% of the respondents answered with 'don't know' and 7,5% answered with 'I trust no one'. Results of the second survey show, that 11% of respondents don't know whom to trust and 5,5% of respondents trusts no one. Friedman test shows, that respondent's level of trust have changed significantly between the surveys. ($\chi^2=14,706$, sig. = 0,00, df=1). Trust in all sources of information dropped, except for the trust in NGO information.

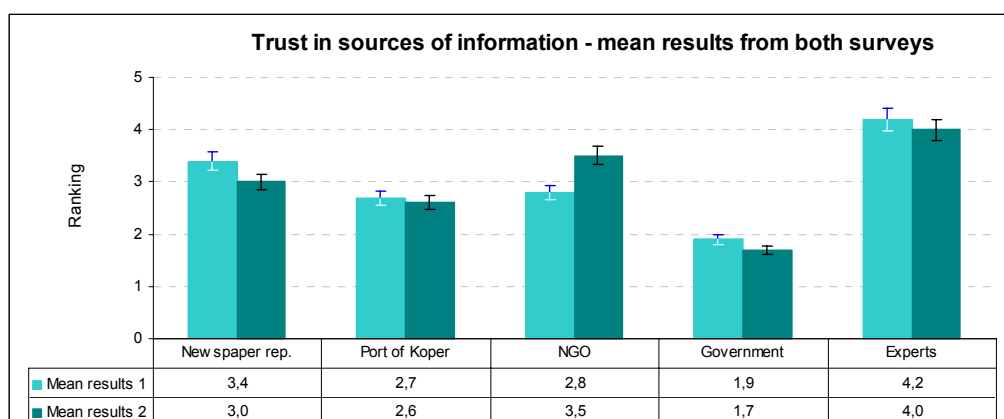

Graph A4/ 10: Trust in sources of information – general results comparison of 1st and 2nd survey results

Trust in sources of information about PK impact Q-4				
Y_i	$X_{i(i=3-7)}$	X_1 / X_2	ΔA	
Experts		PK / GP similar result	1st s. / 2nd s down	• Y_i - opinion on the subject
Reporters		PK / GP similar result	1st s. / 2nd s down	• $X_{i(i=3-7)}$ - control variables (education, employment, gender, location)
NGO		PK / GP less/more	1st s. / 2nd s up	• X_1/X_2 - general population/ employees
Port of Koper		PK / GP more/less	1st s. / 2nd s down	• PK / GP high/low - employees grade the option significantly different than general population
Government		PK / GP similar result	1st s. / 2nd s similar	• 1st s. / 2nd s down - results of the 2 nd survey are significantly lower than in the 1 st survey
Don't know Noone		PK / GP similar result	1st s. / 2nd s - up	• 1st s. / 2nd s up - results of the 2 nd survey are significantly higher than in the 1 st survey

Graph A4/ 11: Significant differences – trust in sources of information

Interpretation of the table

- Variables of interest are stated (Yi) in the first column for each question.
- In second column extraneous variables, which have significant influence on results are written and marked with red. If the box is empty, there is no significant influence of extraneous variables.
- In the third column the comparison of group of general public and group of employees is marked. In the case that difference between the two groups is significant, its box is marked with red colour and the description of the difference is written (more/less), which describes the grade, given by the group.
- The fourth column marks differences between 1st and 2nd survey (if the question was answered twice). Green colour shows that results were higher in 2nd survey than in the 1st one, yellow colour shows results lower in 2nd results. If the box is black, the difference is not significant.

Equations:

$$\Delta ep_{(1-4)}^1 = y_{(1-4)p}^1 - y_{(1-4)e}^1 \quad (1)$$

$$\Delta ep_{(1-4)}^2 = y_{(1-4)p}^2 - y_{(1-4)e}^2 \quad (2)$$

$$\Delta E_{(1-4)} = y_{(1-4)e}^2 - y_{(1-4)e}^1 \quad (3)$$

$$\Delta P_{(1-4)} = y_{(1-4)p}^2 - y_{(1-4)p}^1 \quad (4)$$

$$\Delta A_{(1-4)} = \Delta P_{(1-4)} - \Delta E_{(1-4)} \quad (5)$$

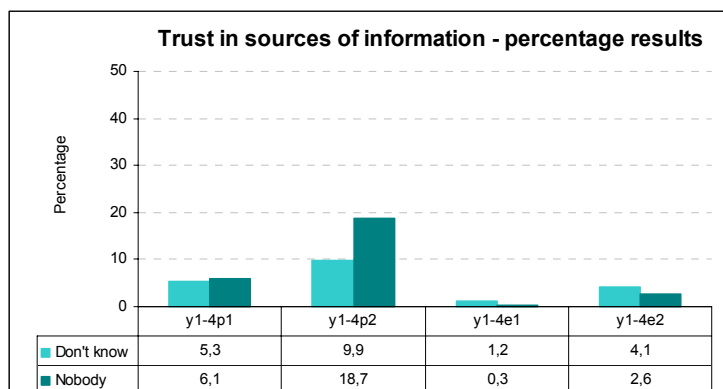

Graph A4/ 12: Trust in sources of information – percentage table of ‘don’t know’ and ‘nobody’ answers

Wilcoxon Signed Rank Test – Respondents from the group of PK employees

Table A 4/ 1
Wilcoxon Signed Rank Test - Respondents: Employees

Test Statistics^c

	PK Newspaper rep. 2 - PK Newspaper rep. 1	PK Port of Koper 2 - PK Port of Koper 1	PK NGO 2 - PK NGO 1	PK Government 2 - PK Government 1	PK Experts 2 - PK Experts 1
Z	-,596 ^a	-2,723 ^a	-3,849 ^b	-,219 ^b	-,405 ^a
Asymp. Sig. (2-tailed)	,551	,006	,000	,827	,685

- a. Based on positive ranks.
- b. Based on negative ranks.
- c. Wilcoxon Signed Ranks Test

Table A 4/ 2
Wilcoxon Signed Rank Test – Respondents from general population

Test Statistics^c

	Reporters 2 - Reporters 1	Port of Koper 2 - Port of Koper 1	NGO 2 - NGO 1	Government 2 - Government 1	Experts 2 - Experts 1
Z	-3,727 ^a	-,052 ^a	-3,133 ^b	-1,130 ^a	-,775 ^a
Asymp. Sig. (2-tailed)	,000	,959	,002	,259	,438

- a. Based on positive ranks.
- b. Based on negative ranks.
- c. Wilcoxon Signed Ranks Test

A 4/ 4.1.2 Effectiveness of information modes (EIM) which were used by Port of Koper authorities in informing public about their activities and impacts

Respondents were asked in question Q-11 to rank modes of information according to their importance. The question was: *Which mode of information, organized by the Port of Koper about their activities was the most suitable and effective for you: (Please rank three most important in the order of importance with 1= the most important, 2=a bit less important ... and 5=the least important):*

- TV news
- Information on the internet
- Newspaper articles
- Radio broadcasting
- 'Open door' days in the Port
- Public presentations in EIA process
- None of them
- I do not know

Table A 4/ 3
EIM, used by Port of Koper authorities in informing public about their activities and impacts (N=383)

Descriptive Statistics					
	N	Minimum	Maximum	Mean	Std. Deviation
TV News	272	1	5	3,57	1,359
Internet	145	1	5	2,07	1,078
Newspaper reports	276	1	5	3,43	1,184
Radio news	238	1	5	2,94	1,105
Open dor in PK	204	1	5	2,75	1,560
Public presentations	228	1	5	2,77	1,572

TV news is graded as the most effective mode available (mean=3,57), followed by Newspaper reports (mean=3,43) and the Radio news (mean=2,94). Public presentations are in fifth place (mean=2,77), followed by Open door days in the Port (mean=2,75). The least effective source considered is the Internet.

Analysis of results in the common group shows, that many respondents did not find any of the stated information modes very effective, since 11,7% of respondents from the general population thinks none of them is effective and 10,4% answered 'don't know'.

Correlation occurs in analysis of Newspaper reporters according to education (Spearman' ρ =0,212, N=276, Sig. (2-tailed)=0,000) Respondents with higher education consider radio news as less effective (mean=3,19) than people with lower education (mean =3,42 – 3,80) and students (mean=4,42). Differences among groups are significant (Kruskal Wallis χ^2 =16,872, N=276, Asymp.Sig.=0,002).

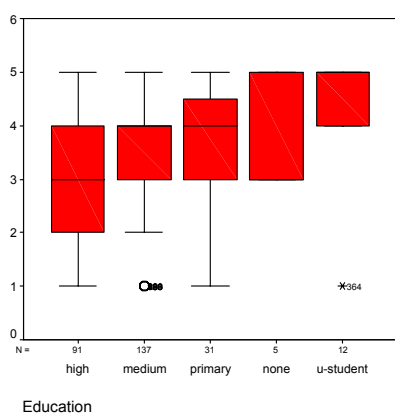

Graph A4/ 13: EIM– newspaper reports –influence of ex. variable education

Report				
Newspaper reports				
Education	Mean	N	Std. Deviation	
high	3,19	91	1,163	
medium	3,42	137	1,180	
primary	3,74	31	1,064	
none	3,80	5	1,095	
u-student	4,42	12	1,165	
Total	3,43	276	1,184	

Correlation occurs also in analysis in effectiveness of Newspaper reports according to employment, where employed people rank it lower (mean=3,30) than non-employed (mean=3,81) or retired people.

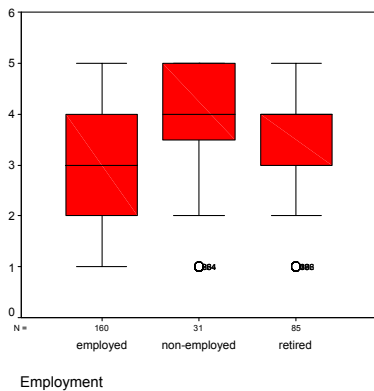

Report

Newspaper reports

Employment	Mean	N	Std. Deviation
employed	3,30	160	1,159
non-employed	3,81	31	1,376
retired	3,54	85	1,129
Total	3,43	276	1,184

Graph A4/ 14: EIM – newspaper reports –influence of ex. variable employment

A correlation occurs also in the analysis of Radio news and employment. (Spearman' $\rho=0,162$, $N=276$, Sig. (2-tailed)= $0,012$). Employed and non-employed people find radio news less effective than retired people.

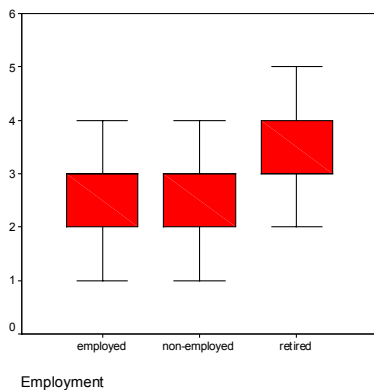

Report

Radio news

Employment	Mean	N	Std. Deviation
employed	2,82	136	1,069
non-employed	2,63	24	1,096
retired	3,26	78	1,110
Total	2,94	238	1,105

Graph A4/ 15: EIM – radio news –influence of ex. variable employment

There is also a correlation among information provided by Open door days in the port and employment (Spearman' $\rho=-0,140$, $N=276$, Sig. (2-tailed)= $0,046$), where employed people find it more important than others.

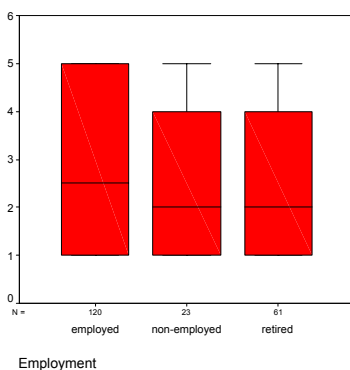

Report

Open dor in PK

Employment	Mean	N	Std. Deviation
employed	2,93	120	1,602
non-employed	2,74	23	1,573
retired	2,41	61	1,430
Total	2,75	204	1,560

Graph A4/ 16: EIM – open door days in PK –influence of ex. variable employment

Presentations in EIA procedure were held in the City of Koper and in Ankaran. Information about the presentation in the City of Koper was given in a way, which is defined by the environmental protection law – that means the information about presentation in the local newspaper. The information about presentation in Ankaran was given in the local newspaper, radio and local TV and was much more successful.

In the A4/4.18 are presented a descriptive data on opinion about effectiveness of information modes of respondents from Ankaran, City of Koper and group of employees.

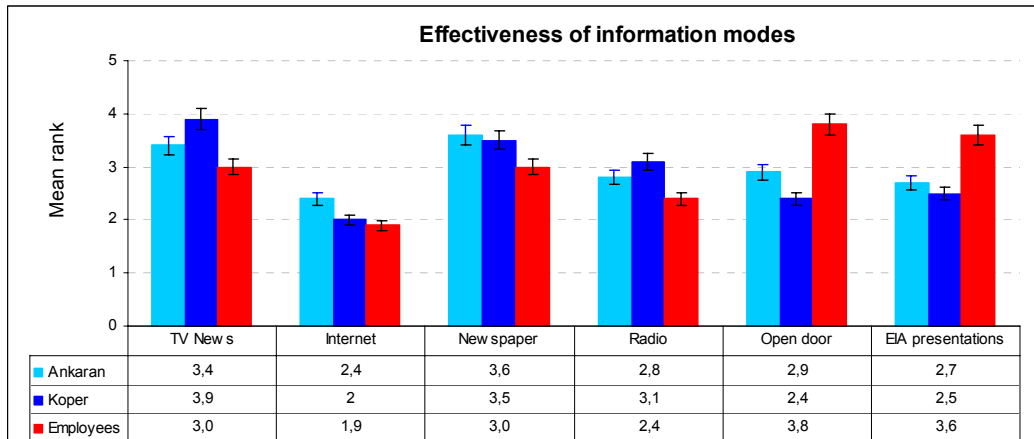

Graph A4/ 17: EIM –influence of location of residency (Ankaran, City of Koper) vs. employees

Respondents from Ankaran grade Open door days and Public presentations higher than respondents from City of Koper, but still lower than respondents from the group of employees.

The difference in opinion on effectiveness of Open door approach is significant between respondents from Koper (mean=2,7) and Ankaran (mean=2,9). (Wilcoxon Signed Rank Test: $Z=-2,208$, Asymp. Sig. (2-tailed) = 0,027) and between respondents from City of Koper (mean=2,38) and employees of the Port (mean=3,76). (Wilcoxon Signed Rank Test: $Z=-3,151$, Asymp. Sig. (2-tailed) = 0,002) and in opinion on Public presentation efficiency (Wilcoxon Signed Rank Test: $Z=-2,001$, Asymp. Sig. (2-tailed) = 0,045). Other differences look big, but are not statistically significant, probably due to too small samples from some locations.

Table A 4/ 4

Wilcoxon Signed Ranks Test: respondents from City of Koper, Ankaran and group of employees on 'Open door days' and Public presentation'

Test Statistics ^b			Test Statistics ^b		Test Statistics ^b		
	PK employees - Open door in PK - Koper - Open door in PK	PK employees - Public presentations - Koper - Public presentations	Z	PK-Public presentations - Public presentations	Z	Koper - Open door in PK - Ankaran - Open door in PK	Koper - Public presentations - Ankaran - Public presentations
Z	-3,151 ^a	-2,001 ^a	Z	-2,292 ^a	Z	-2,208 ^a	-,553 ^a
Asymp. Sig. (2-tailed)	,002	,045	Asymp. Sig. (2-tailed)	,022	Asymp. Sig. (2-tailed)	,027	,580

a. Based on negative ranks.
b. Wilcoxon Signed Ranks Test

a. Based on negative ranks.
b. Wilcoxon Signed Ranks Test

a. Based on positive ranks.
b. Wilcoxon Signed Ranks Test

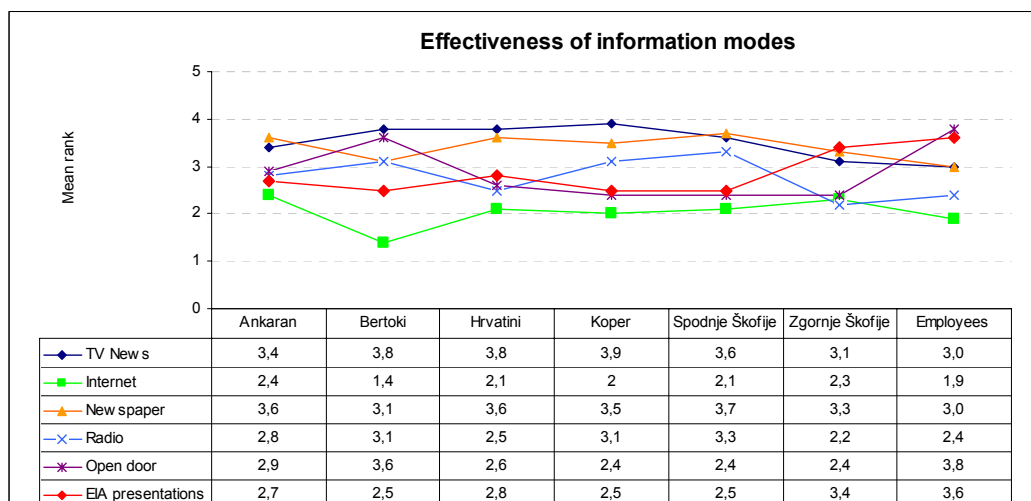

Graph A4/ 18: Opinion information modes effectiveness according to residency, vs. employees

Mode of information, organized by PK Q-11

iY_i	$X_{i(=3-7)}$	X_1 / X_2
TV News		PK / GP similar results
Newspapers	- education - employment	PK / GP similar results
Radio news	- education - employment	PK / GP similar results
Open door days in PK	- employment	PK / GP high/low
EIA public presentations		PK / GP high/low
Internet		PK / GP similar results
Nobody		PK / GP similar result

- iY_i - opinion on the subject
- $X_{i(=3-7)}$ - control independent variables (education, employment, gender, location)
- X_1/X_2 - independent variables – general population/ employees
- | |
|------------------|
| PK / GP high/low |
|------------------|

 - employees grade the option significantly different than general population

Graph A4/ 19: Significant differences – EIM, used by Port of Koper authorities in informing public about their activities and impact

Table A 4/ 5
Wilcoxon on Signed Rank Test: Differences in opinion between group of general population and group of employees

Test Statistics ^c						
	PK Open dor in PK - Open dor in PK	PK TV News - TV News	PK Internet - Internet	PK Newspaper reporters - Newspaper reporters	PK Radio news - Radio news	PK Public presentations - Public presentations
Z	-1,723 ^a	-1,627 ^b	-1,040 ^b	-1,242 ^b	-,893 ^b	-2,292 ^a
Asymp. Sig. (2-tailed)	,048	,104	,298	,214	,372	,022

- a. Based on negative ranks.
- b. Based on positive ranks.
- c. Wilcoxon Signed Ranks Test

A 4/ 4.1.3 Reliability of sources in informing public about Port of Koper activities and impacts

Respondents were asked in question Q-14 to grade which source of information was the most reliable in informing the public about Port of Koper's activities and impacts of them: newspaper reporters, Port of Koper, NGO, government, experts, rumours, gossip, I do not know or none of them.

Table A 4/ 6
Effectiveness and reliability of sources in informing public about Port of Koper activities and impacts – descriptive data (N=383)

Descriptive Statistics						
	N	Minimum	Maximum	Mean	Std. Deviation	
Reporters	272	1	5	3,77	1,323	
Port of Koper	219	1	5	2,91	1,421	
NGO	217	1	5	3,48	1,368	
Government	74	1	5	1,89	1,001	
Municipality	205	1	5	2,16	1,082	
Experts	255	1	5	3,16	1,198	
Gossip	140	1	5	2,39	1,285	

From the stated sources reporters are graded as the most reliable and effective source of information (mean=3,77). The second source is NGO's (mean=3,48), and experts are the third choice (mean=3,16). The Port of Koper's authorities information (mean=2,91) is considered a bit more helpful than gossip (mean=2,39). Government is graded as the least helpful source of information (mean=1,89).

There is a statistically significant difference in opinion on **reporters information** among respondents of different gender, where male respondents (mean=3,92) grade its' effectiveness significantly higher than female respondents (mean=3,57). (Kruskal Wallis $\chi^2=4,905$, $df=1$, Asymp.Sig.=0,027)

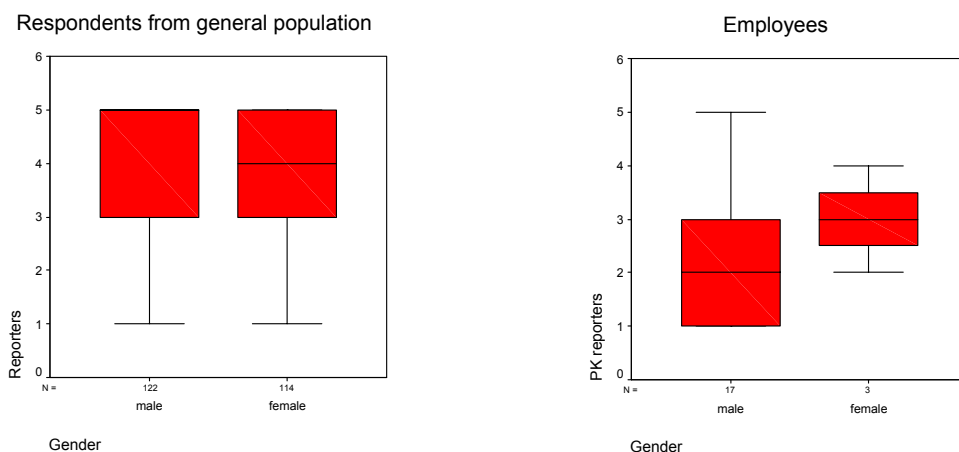

Graph A4/ 20: Employees vs. general population analysed according to gender – reporters information

We can see, that female respondents in both groups grade reporter's information higher, although respondents of each gender from respondents from the general population grade it higher than employees.

Opinions about the **Port authorities** as a source of information differ among respondents from different locations of residency and employees of the Port. Employees of the Port find it most useful (mean=3,97), followed by residents of Hrvatini (mean=3,92). People from City of Koper grade the information significantly lower (mean=2,75) (Wilcoxon Signed Rank Test $z=-3,488$, Asymp. Sig. (2-tailed)=0,00), which is also the case in Bertoki (mean=2,11) and Spodnje Škofije (mean=2,22). Opinion of respondents from Ankaran and Zg. Škofije is between them (mean=3,11 and 2,92). There is a statistically significant difference between opinions of the general population and those of the group of employees ($z=-1,98$, Asymp. Sig. (2-tailed)=0,047) where employees grade it significantly higher than the general population ($\Delta\mu=-1,30$)

Respondents from different locations graded **NGO** information significantly different when we compare pairs of respondents. Respondents from Bertoki (mean=4,5), Sp. Škofije (mean=3,6) and Ankaran (mean=3,48) grade it high, whereas employees of the Port of Koper (mean=2,98) grade it low. (Wilcoxon Signed Rank Test $z=-2,209$, Asymp. Sig. (2-tailed)=0,027).

All groups on all locations grade the **government** as a source of information low. **Municipality** information was graded a bit higher than governmental information. People gave the highest grade from Zg. Škofije (mean=2,55) and Hrvatini (mean=2,4) and the lowest by residents of Sp. Škofije (mean=1,6) and Port of Koper (mean=1,96), but difference is not statistically significant

There is a significant difference in opinion on **expert information** among genders, where female respondents (mean=3,39) grade it as more effective source of information than male respondents (mean=2,99). (Kruskal Wallis $\chi^2=6,135$, $df=1$, Asymp.Sig.=0,013).

There is also significant difference in opinion about expert information in analysis according to education, where people with a high education (mean=3,42) and students at the university (mean=3,15) grade it higher than people with medium (mean=3,014), primary (mean=2,92) and no education (mean=2,60). Experts are considered more useful source of information in Sp. Škofije (mean=3,44) and in the Port of Koper (mean=3,38) than at other locations (mean=2,93 – 3,12). Respondents from Hrvatini gave a significantly lower grade. (mean=1,62).

Gossip is graded higher than municipality and governmental information. People from Hrvatini (mean=3,0) graded it highest, and employees of the Port of Koper (mean=1,82) graded it the lowest.

There are some differences in opinion between the group of employees and the general population and are statistically significant in answers about 'Port of Koper' information ($z=-1,98$, Asymp. Sig. (2-tailed)=0,047).

9,4% of respondents from the general public thinks that **none** of these sources of information is useful. The biggest part of these respondents is 36-55 years old and is of both genders, most of them is employed and has medium education. 12,3% of respondents from the general public responded with 'don't know'. 0,9% respondents from the group of employees trust nobody and 2,6% of them 'don't know whom to trust'.

Table A 4/ 7
Comparison among group of general population and group of employees

Test Statistics^c

	PK Newspaper reporters - Reporters	PK Port of Koper - Port of Koper	PK NGO - NGO	PK Government - Government
Z	-2,287 ^a	-1,984 ^a	-2,827 ^a	-1,342 ^b
Asymp. Sig. (2-tailed)	,022	,047	,005	,180

- a. Based on positive ranks.
- b. Based on negative ranks.
- c. Wilcoxon Signed Ranks Test

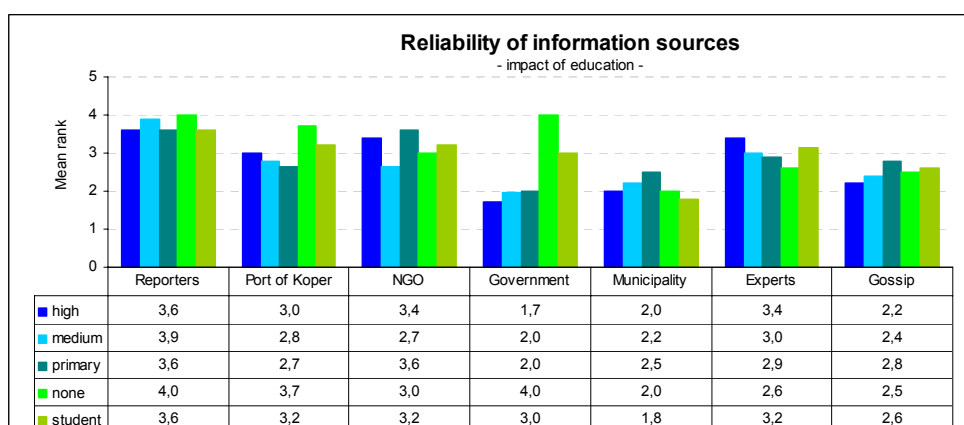

Graph A4/ 21: Mean rank opinion according to education

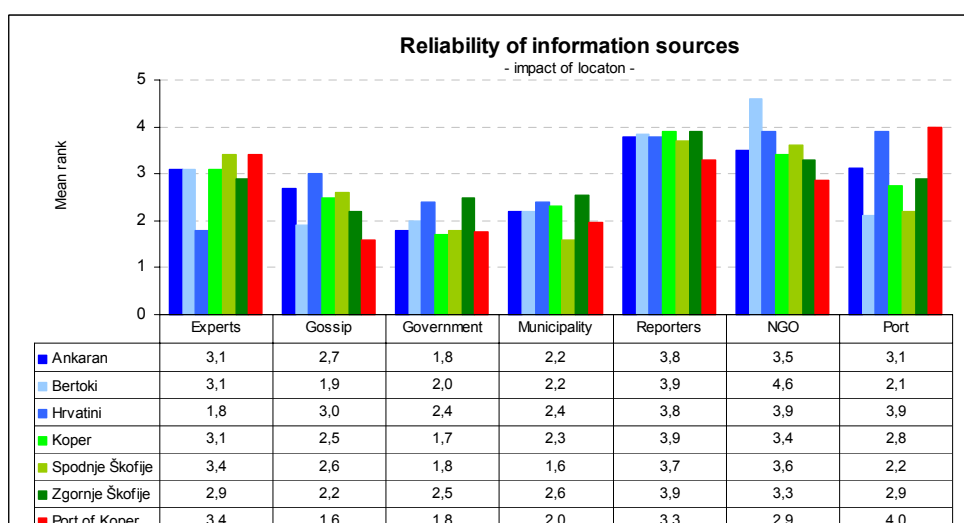

Graph A4/ 22: Mean rank opinion according to location of residency

Effectiveness of sources of information about PK issues (Q-14)

Y_i	$X_{i(3-7)}$	X_1 / X_2
Reporters	- gender	PK / GP less/more
NGO		PK / GP less/more
Experts	- gender	PK / GP similar result
Port of Koper	- location	PK / GP more /less
Gossip		PK / GP similar result
Municipality		PK / GP similar result
Government		PK / GP more/less
Don't know Nobody		PK / GP similar result

- Y_i - opinion on the subject
- $X_{i(3-7)}$ - control variables (education, employment, gender, location)
- X_1/X_2 - general population/ employees

PK / GP high/low - employees grade the option significantly different than general population

Graph A4/ 23: Significant differences – Effectiveness and reliability of information sources, provided by Port of Koper authorities

A 4/ 4.1.4 Effectiveness of information modes for informing public about changes in environmental quality in coastal area

Respondents were asked in question Q-16 to grade which mode of information about changes in environmental quality in coastal area was the most effective: TV News, Internet, newspaper reporters, Radio news, gossip, NGO, public presentations, do not know or none of them.

Table A 4/ 8 Effectiveness of information modes about environmental issues– descriptive data (N=383)

Descriptive Statistics					
	N	Minimum	Maximum	Mean	Std. Deviation
TV News	304	1	5	3,90	1,251
Internet	112	1	5	2,13	1,103
Newspapers	306	1	5	3,45	1,153
Radio news	272	1	5	2,94	1,084
Gossip	111	1	5	1,93	1,059
NGO	235	1	5	2,63	1,504
Public presentations	218	1	5	2,62	1,559

TV news is considered the most useful and effective source of information from all (mean=3,9). The second are newspapers (mean=3,4) followed by the radio news (mean=2,9). NGO presentations (mean=2,6) and public presentations in EIA process (mean=2,6) are fourth and fifth. The last two are Internet (mean=2,1) and gossip (mean=1,9).

There is a correlation between education and opinion on public presentation in the EIA process, where people with a high education (mean=2,8), grade it higher than respondents with medium education (mean=2,7), primary education (mean=1,9) or students (mean=1,9). (Spearman's $\rho = -1,51$, Sig.(2-tailed)=0,026)

A significant difference occurs in opinion of radio news effectiveness among respondents of different age, where respondents aged 45-65 grade the radio news higher than others. (Kruskal Wallis $\chi^2 = 14,16$, df=6, Asymp.Sig.=0,028).

There are some differences in opinion about effectiveness of NGO presentations, public presentations in the EIA process and gossip among respondents from different locations of residency and employees of the Port of Koper, but they are not statistically significant. Employees of the Port grade the EIA presentations highest of all (mean=3,0) and give the lowest grade to NGO presentations' information (mean=2,36). People from other locations

grade these two sources similarly, except for respondents from Hrvatini, who grade NGO information higher (mean=3,1) and EIA presentations lower (mean=2,7). These differences might be due to very active NGO group organized primarily in Hrvatini that are very active in every public presentation in the area.

The biggest difference between the main groups is in opinion on the public presentation in the EIA process, where group of employees grade it higher than the general population, but the difference is not statistically significant.

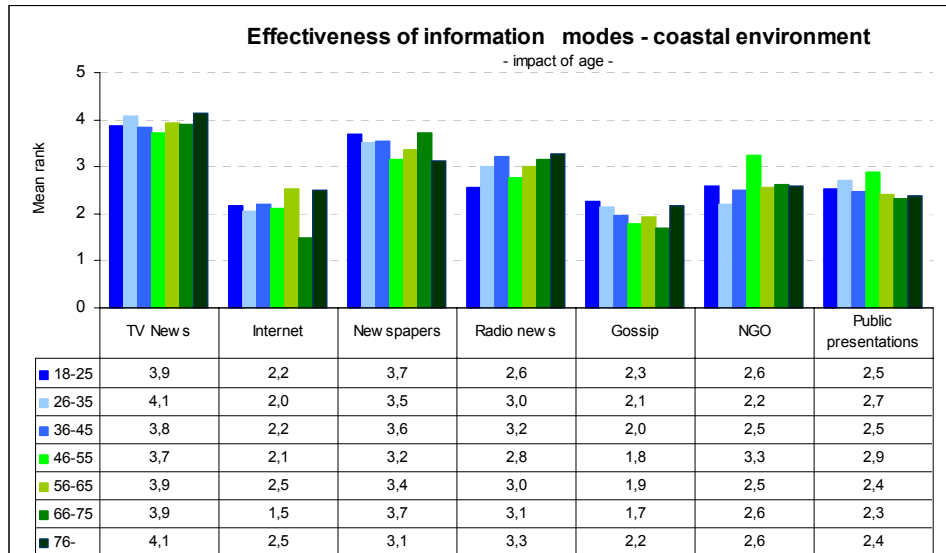

Graph A4/ 24: Effectiveness and suitability of information modes about changes in environmental quality in coastal area – ex. Variable: age (means)

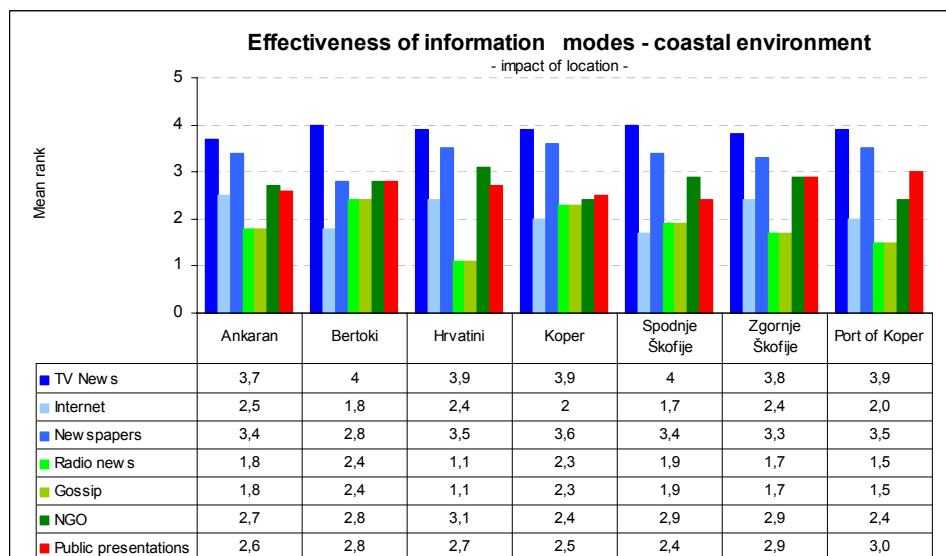

Graph A4/ 25: Effectiveness of information modes about changes in environmental quality in coastal area – ex. Variable: location of residency and employees of the port (means)

Kruskal-Wallis Test for influence of extraneous variables – age and education.

Table A 4/ 9

Effectiveness of information modes about environmental issues – influence of variables education and age

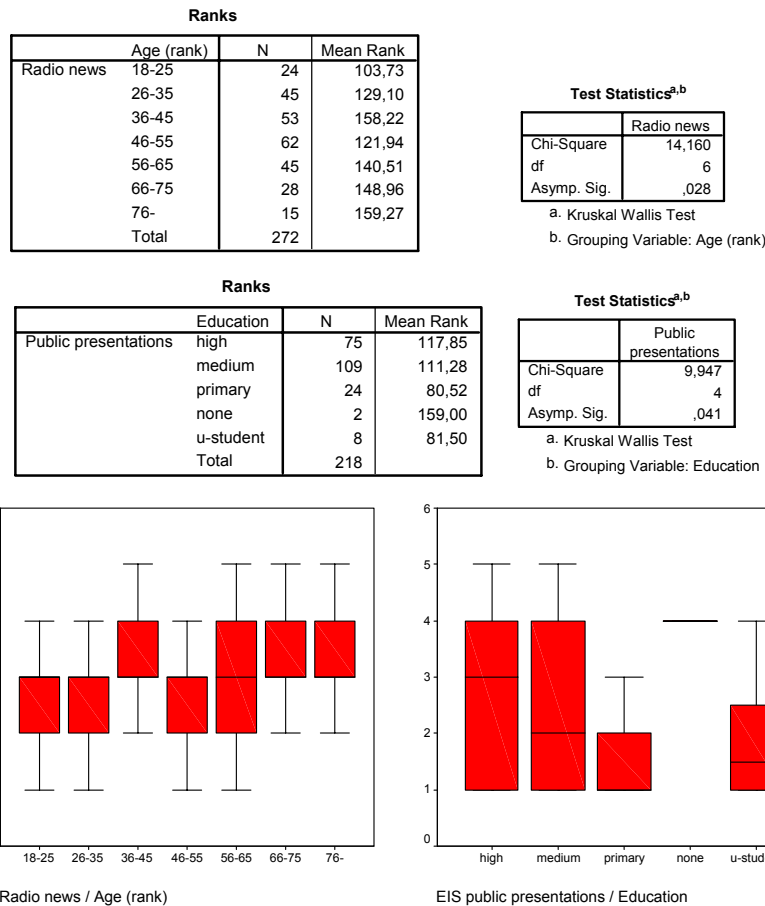

Graph A4/ 26: Effectiveness and suitability of information modes – Radio news/age and EIS/education

A 4/ 4.1.5 Effectiveness of information modes for informing public about Port of Koper' environmental impact

Respondents were asked in question Q-17 to grade which mode of information was the most effective and suitable for informing the public about the Port of Koper' environmental impact: TV news, Internet, newspaper reporters, Radio news, gossip, NGO, public presentations or none of them.

Table A 4/ 10

Effectiveness of information modes in informing public about Port of Koper' environmental impact – descriptive data (N=383)

Descriptive Statistics						
	N	Minimum	Maximum	Mean	Std. Deviation	
TV News	273	1	5	3,77	1,310	
Internet	90	1	5	2,04	1,170	
Newspaper	278	1	5	3,51	1,123	
Radio news	255	1	5	2,92	1,095	
Gossip	130	1	5	2,22	1,181	
NGO presentations	207	1	5	2,67	1,535	
EIA presentations	175	1	5	2,59	1,551	

TV news is considered the most useful and effective source of information (mean=3,8). The second are newspapers (mean=3,5) and radio news (mean=2,9). NGO presentations

(mean=2,7) and public presentations in EIA process (mean=2,6) are fourth and fifth. The last two are gossip (mean = 2,22) and the Internet (mean=2,0).

There is a significant difference in opinion of people with different level of education about public presentations organized by NGO's, where people with a high education (mean=2,87), grade it higher than respondents with medium education (mean=2,61), primary education (mean=2,57) or students (mean=2,63). (Kruskal Wallis $\chi^2=8,170$, $df=3$, Asymp.Sig.=0,043). Pattern is similar in most locations, although we can see that respondent from Ankaran grade Internet information higher then others (mean=2,8). The difference is statistically significant in a comparison of Ankaran to employees of the Port of Koper (Wilcoxon Signed Ranks $Z=-2,032$, Asymp. Sig. (2-tailed)=0,042). People in Bertoki rank NGO presentations and gossip higher than others do, but difference is not statistically significant.

Employees of the Port of Koper (mean=3,4) grade the effectiveness of the EIA presentations significantly higher than others (mean=2,4)(Wilcoxon Signed Ranks $Z=-2,177$, Asymp. Sig. (2-tailed)=0,021).

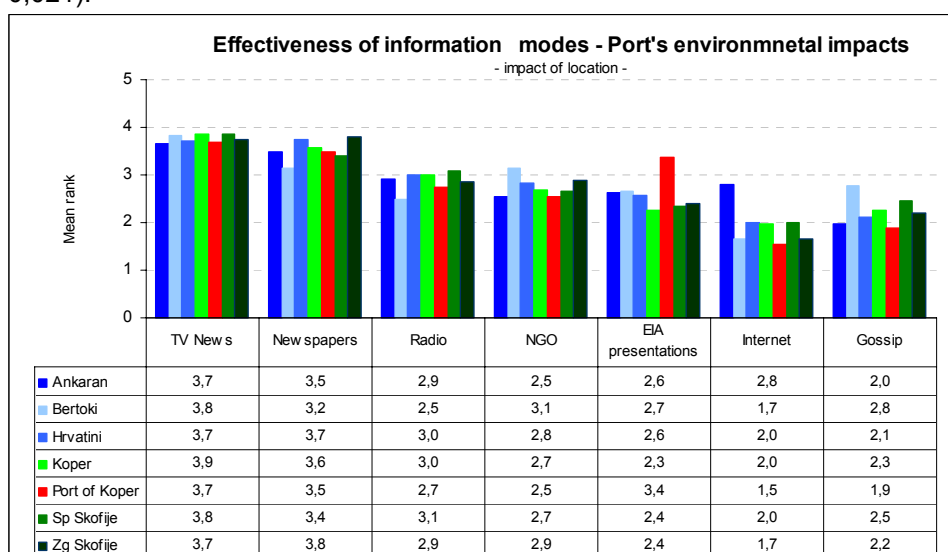

Graph A4/ 27: Mean rank opinion according to location

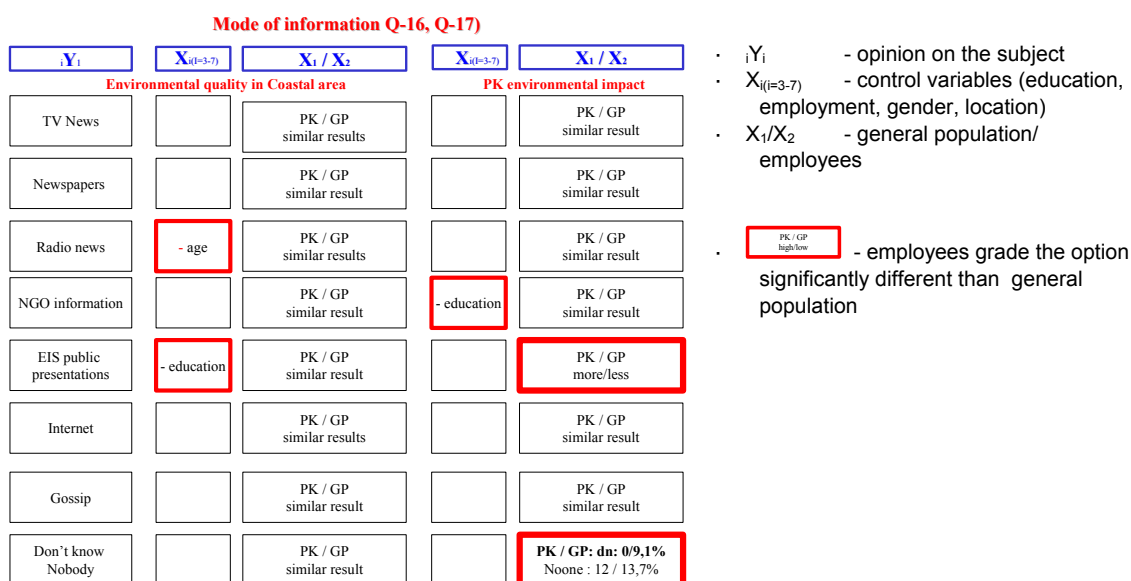

Graph A4/ 28: Significant differences – effectiveness of information modes in informing public about PK EI

Kruskal-Wallis Test

Table A 4/ 11
Influence of education

Ranks				Test Statistics ^{a,b}	
	Education	N	Mean Rank		NGO presentations
NGO presentations	high	78	107,86	Chi-Square	8,170
	medium	94	97,60	df	3
	primary	23	95,33	Asymp. Sig.	,043
	none	4	30,00		
	Total	199			

a. Kruskal Wallis Test
b. Grouping Variable: Education

A4/2 VARIABLE Y2: PRIORITIES IN PORT OF KOPER DEVELOPMENT

Respondents were asked to mark the most important issue for the development of the Port of Koper. Issues addressed in this question are:

- 1 - concern for safety in transportation and processing in Port of Koper
- 2 - concern for jobs
- 3 - concern about disturbance of Ankaran by the Port of Koper
- 4 - concern for pollution prevention in the Port of Koper

1st survey

Results for Q5- the 'Priorities in Port of Koper development' is the following:

Table A 4/ 12
Priorities in Port of Koper development – frequency table of the 1st survey

		Opinion			
		Frequency	Percent	Valid Percent	Cumulative Percent
Valid	safety	101	34,5	34,5	34,5
	employment	21	7,2	7,2	41,6
	disturbance of Ankaran	22	7,5	7,5	49,1
	environmental protection	149	50,9	50,9	100,0
	Total	293	100,0	100,0	

From the frequency table we can see, that concern for pollution prevention is considered the most important issue, even more than the concern expressed about safety in transportation and processing. Both issues are interconnected and it was probably difficult to decide which one to choose. It also involves an understanding, that good technological and safety procedures are conditional for pollution prevention. If we take it inverse - pollution prevention is achieved by good processing technology and successful safety measures. Another possibility for understanding of the concern for environmental problems is 'no action' alternative - a fundamental approach. It is not possible to distinguish among the two of them from these questions.

Cross tabulation shows that male respondents are more concerned about safety in the port, employment opportunities offered by the Port and about the disturbance of the neighbouring town of Ankaran. Women respondents are more concerned about environmental protection in general than male respondents.

We also compared opinions from different locations of residency were, respondents from the group of employees represent a special group. We can see that opinions of groups differ.

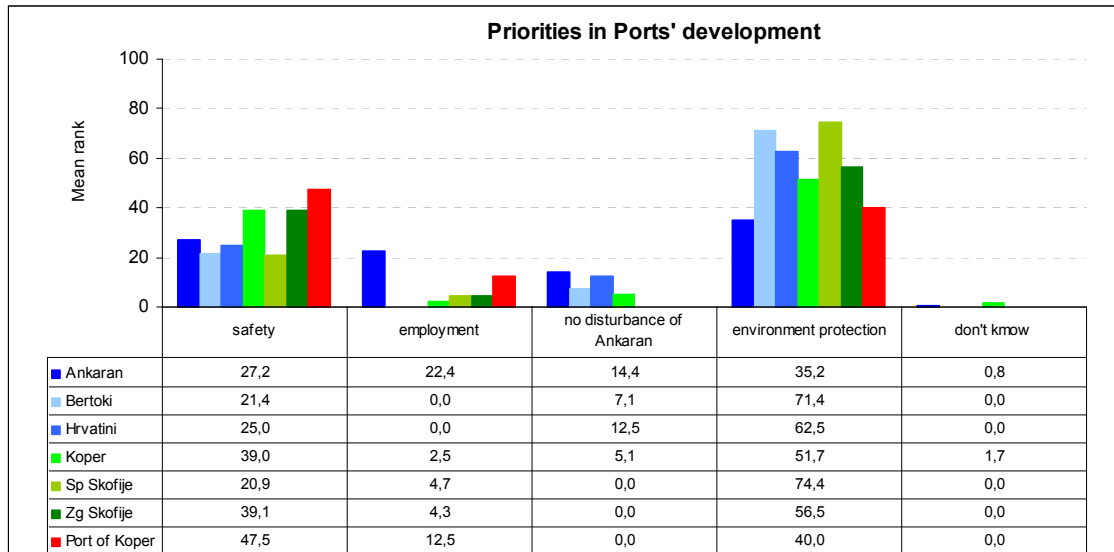

Graph A4/ 29: Opinion of respondents from different location of residency - 1st survey

A significant difference occurs in a comparison of employees of the Port, who are concerned mostly for safety and a bit less for environmental protection. Respondents from the general public are concerned mostly about environmental protection in the Port of Koper. Respondents from Bertoki (71%) express the highest concern for environmental protection. The highest interest in employment opportunities in the Port of Koper is expressed by respondents from City of Koper (11,9%). Respondents from Ankaran show the highest concern about disturbance of Ankaran by the Port of Koper (24%).

2nd survey

Table A 4/ 13
Priorities in Port of Koper development – frequency table of the 2nd survey

Opinion				
	Frequency	Percent	Valid Percent	Cumulative Percent
Valid	8	2,1	2,1	2,1
safety	125	32,6	32,6	34,7
employment	11	2,9	2,9	37,6
disturbance of Ankaran	30	7,8	7,8	45,4
environment protection	206	53,8	53,8	99,2
don't know	3	,8	,8	100,0
Total	383	100,0	100,0	

Results of the second survey are similar to the first one i.e., environmental protection is considered the most important issue.

Results aggregation

A significant difference occurs when comparing employees - respondents of the Port with respondents from the general population. Employees are concerned mostly about safety and a bit less for environmental protection whereas respondents from the general public are concerned mostly about environmental protection in Port of Koper. Concern for safety dropped in the group of employees between both surveys. At the same time concern for environmental protection and employment opportunities have risen. Among the respondents from the general population the concern for safety and environmental protection remained the same in both surveys.

Priorities in PK development (Q-5)				
Y_i	$X_{i(i=3-7)}$	X_1 / X_2	ΔA	
Environmental protection		PK / GP less/more	1st / 2nd PK up	<ul style="list-style-type: none"> Y_i - opinion on the subject $X_{i(i=3-7)}$ - control variables (education, employment, gender, location) X_1/X_2 - general population/ employees
Safety in transportation		PK / GP more/less	1st / 2nd PK down	<ul style="list-style-type: none"> PK / GP high/low - employees grade the option significantly different than general population
No disturbance of Ankaran	- location	PK / GP similar	1st / 2nd similar result	<ul style="list-style-type: none"> 1st s. / 2nd s down - results of the 2nd survey are significantly lower than in the 1st survey
Job opportunities		PK / GP similar	1st / 2nd down	<ul style="list-style-type: none"> 1st s. / 2nd s up - results of the 2nd survey are significantly higher than in the 1st survey

Graph A4/ 30: Significant differences – priorities in Port of Koper development

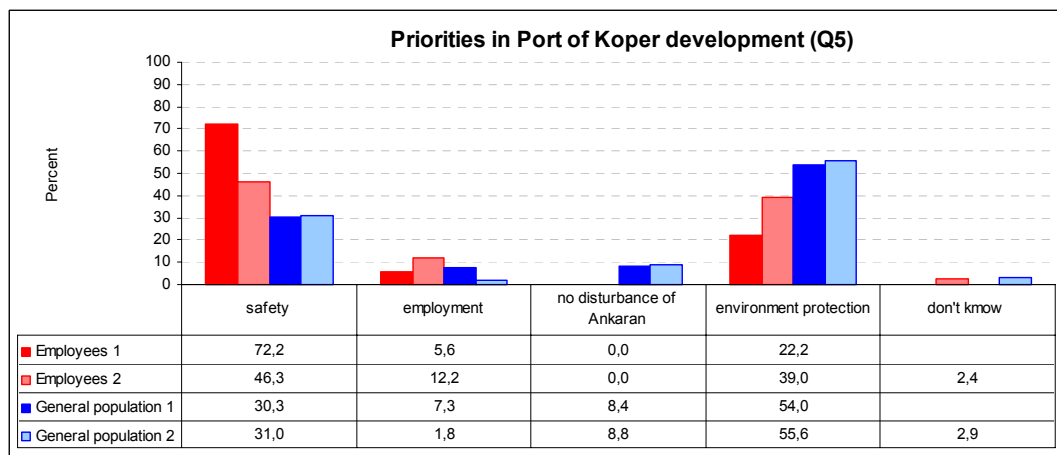

Graph A4/ 31: Q5 percentage table - comparison of 1st and 2nd survey results

A4/3 VARIABLE Y3: VALUE STRUCTURE IN THE SOCIETY

Respondents were asked to rank the following goals according to the level of importance for Slovenia: clean and healthy environment, solid economy, economic growth, humane society, and freedom of speech

Mean results of 2001 and 2003 survey

Table A 4/ 14

Results of 2001 and 2003 survey - Means – Importance of society goals

	N ₁	Mean ₁	Std. Deviation ₁	N ₂	Mean ₂	Std. Deviation ₂
Clean and healthy environment	270	3,6	1,20	344	1,23	3,4
stable economy	270	3,9	1,17	344	1,23	3,7
Economic growth	270	3,1	1,28	344	1,34	3,1
Humane society	270	2,6	1,21	344	1,44	2,9
Freedom of speech	270	1,8	1,19	344	1,14	1,9

Table A 4/ 15

Results of 2001 and 2003 survey- Importance of society goals/age

Age	Clean and healthy environment		Stable economy		Economic growth		Humane society		Freedom of speech	
	2001	2003	2001	2003	2001	2003	2001	2003	2001	2003
18-25	3,3	3,0	4,1	4,0	3,4	3,4	2,4	2,7	1,9	2,0
26-35	3,0	3,4	3,9	3,5	3,4	3,2	2,5	2,9	2,2	1,9
36-45	3,8	3,3	3,7	3,6	3,1	3,2	2,5	2,9	1,8	2,1
46-55	3,7	3,6	4,0	3,5	3,0	3,0	2,7	3,0	1,5	1,9
56-65	3,8	3,4	3,8	3,9	2,3	3,1	2,8	2,9	2,4	1,7
66-75	4,0	3,5	3,5	3,8	2,7	3,3	3,0	2,6	1,7	1,9
76-	3,8	3,6	4,2	3,6	3,4	2,7	2,2	2,7	1,2	2,4

Table A 4/ 16

Results of 2001 and 2003 survey- Importance of society goals/education

Age	Clean and healthy environment		Stable economy		Economic growth		Humane society		Freedom of speech	
	2001	2003	2001	2003	2001	2003	2001	2003	2001	2003
high	3,3	3,2	4,0	3,7	3,2	3,1	2,7	3,0	1,8	1,9
medium	3,7	3,6	3,9	3,6	3,0	3,2	2,6	2,8	1,8	1,8
primary	4,1	3,5	3,6	3,7	2,8	2,9	2,7	2,8	1,8	2,1
none	3,8	2,9	3,6	4,4	3,6	3,3	2,6	2,7	1,6	1,7
student	2,6	3,2	4,2	3,5	4,1	2,9	2,2	3,0	2,2	2,5

Table A 4/ 17

Results of 2001 and 2003 survey- Importance of society goals/education

Age	Clean and healthy environment		Stable economy		Economic growth		Humane society		Freedom of speech	
	2001	2003	2001	2003	2001	2003	2001	2003	2001	2003
employed	3,6	3,4	3,9	3,6	3,2	3,2	2,5	3,0	1,7	1,9
unemployed	3,4	3,1	4,1	3,6	3,2	3,1	2,4	2,8	2,0	2,3
retired	3,9	3,6	3,6	3,8	2,6	3,0	2,9	2,7	1,9	1,9
student	2,6	3,2	4,2	3,5	4,1	2,9	2,2	3,0	2,2	2,5

1st survey

Cumulative analysis of all groups shows, that respondents regard a stable economy as the most desired goal in society (mean=3,86). The second goal is considered to be a clean and healthy environment, (mean=3,61) and economic growth (mean=3,08). A humane society is graded much lower (mean=2,69), the least important goal is considered to be freedom of speech (mean = 1,81). Friedman test shows, that respondents grade stated values significantly different ($\chi^2=289,789$, $df=4$, Asymp. Sig. =0,00)

a.) Correlation test shows a significant correlation between age and opinion on importance of *clean and healthy environment* (Spearman's $\rho=-0,19$, sig (2-tailed) = 0,001, $n=270$).

Respondents with a primary education and students in high school grade the importance of this statement the highest (mean = 4,08 – 4,14) Respondents with high education grade it lower (mean=3,28) and university students grade it even lower than that (mean=2,56). It is not surprising than to see, that students give the highest grades to importance of a stable economy and economic growth, but Friedman test shows, that the difference is not significant. There is some difference among opinions of employed, unemployed, retired respondents and students, where retired respondents grade clean and healthy environment highest (mean=3,9) and students grade it lowest (mean=2,71), but Friedman test shows that it is not significant.

b.) Significant difference occurs in opinion on the importance of *a stable economy* among respondents from different age groups (Friedman $\chi^2=14,174$, $df=6$, Asymp. Sig. =0,28).

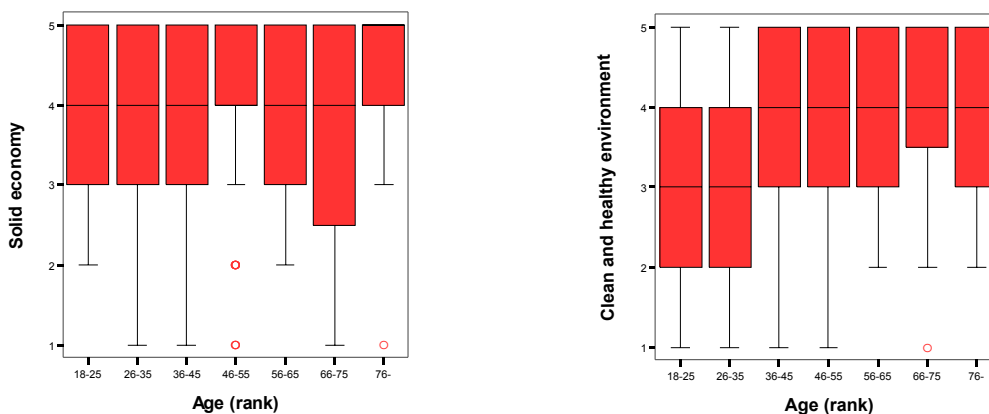

Graph A4/ 32: Opinion on 'Solid economy' and on 'Clean and healthy environment' – influence of age, 1st survey

Another significant difference occurs in the attitude towards the importance of a stable economy in the analysis according to location of residency. It is graded significantly higher in the city of Koper than in other locations ($t=3,023$, $df=99$, sig (2tailed)=0,003). The same group of respondents rates humane society much lower than respondents on other locations, although the difference is not statistically significant ($t=-1,925$, sig(2-tailed)=0,057)

c.) There is a correlation between employment status and opinion on *economic growth* (Spearman's $\rho=-0,149$, sig (2-tailed) = 0,14, $n=270$), where retired respondents consider economic growth much less important than others, and students consider economic growth more important than other groups. The Friedman test shows, that differences in opinions are significant. (Friedman $\chi^2 = 9885$, Asymp. Sig. = 0,020) There is also a correlation between age and opinion on importance of economic growth, where older respondents desire more a clean and healthy environment than younger respondents (Spearman's $\rho=-0,203$, sig (2-tailed) = 0,001, $n=270$).

d.) Necessity of *humane society* was graded low (mean=2,60) Difference in opinion occurs among respondents of different age (Friedman $\chi^2=12,815$, $df=6$, Asymp. Sig. 0,046)

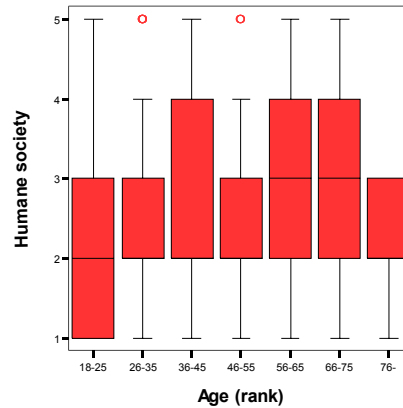

Graph A4/ 33: Opinion on 'Humane society' – influence of age, 1st survey results

There is also difference among value structure according to residency, where a significant difference occurs in Bertoki and in their attitude towards a humane society. Their ranking of the importance of humane society is significantly higher than the ranking on other locations.

e.) Importance of freedom of *speech* was graded the lowest (mean=1,81) Difference in opinion occurs among respondents of different age (Friedman $\chi^2=13,050$, $df=6$, Asymp. Sig. 0,042) There are some differences in opinions among respondents according to location and employees of the Port, but they are not significant.

Kruskal-Wallis Tests for (i) a clean and healthy environment/age, (ii) economic growth/age, (iii) humane society/age, (iv) freedom of speech/age and economic growth/employment.

Table A 4/ 18
Statistical tests

Ranks			
	Age (rank)	N	Mean Rank
Clean and healthy environment	18-25	34	117,60
	26-35	46	97,91
	36-45	62	149,49
	46-55	66	143,60
	56-65	25	142,90
	66-75	27	160,00
	76-	10	144,40
Total		270	

Test Statistics ^{a,b}	
	Clean and healthy environment
Chi-Square	19,370
df	6
Asymp. Sig.	,004

a. Kruskal Wallis Test
b. Grouping Variable: Age (rank)

Ranks			
	Age (rank)	N	Mean Rank
Economic growth	18-25	34	157,87
	26-35	46	157,08
	36-45	62	135,68
	46-55	66	132,68
	56-65	25	91,64
	66-75	27	110,61
	76-	10	154,55
Total		270	

Test Statistics ^{a,b}	
	Economic growth
Chi-Square	18,479
df	6
Asymp. Sig.	,005

a. Kruskal Wallis Test
b. Grouping Variable: Age (rank)

Ranks			
	Age (rank)	N	Mean Rank
Humane society	18-25	34	119,00
	26-35	46	124,99
	36-45	62	126,69
	46-55	66	145,70
	56-65	25	154,60
	66-75	27	158,44
	76-	10	117,55
Total		270	

Test Statistics ^{a,b}	
	Humane society
Chi-Square	9,480
df	6
Asymp. Sig.	,148

a. Kruskal Wallis Test
b. Grouping Variable: Age (rank)

	Age (rank)	N	Mean Rank
Freedom of speech	18-25	34	142,19
	26-35	46	150,90
	36-45	62	141,03
	46-55	66	111,84
	56-65	25	162,54
	66-75	26	128,23
	76-	10	101,60
	Total	269	

	Freedom of speech
Chi-Square	17,545
df	6
Asymp. Sig.	,007

a. Kruskal Wallis Test
b. Grouping Variable: Age (rank)

	Employment	N	Mean Rank
Economic growth	employed	156	144,39
	non-employed	39	143,13
	retired	68	105,61
	student	7	185,14
	Total	270	

	Economic growth
Chi-Square	15,935
df	3
Asymp. Sig.	,001

a. Kruskal Wallis Test
b. Grouping Variable: Employment

2nd survey

Results from the second survey are similar to the first one, but we can see drop of concern for the environment and a stable economy and a rise in concern for a humane society and freedom of speech.

Table A 4/ 19

Value structure on which current society depends – descriptive data of the 2nd survey results (N=364)

	Minimum	Maximum	Mean	Std. Deviation
Clean and healthy environment	1	5	3,50	1,231
Solid economy	1	5	3,65	1,242
Economic growth	1	5	3,04	1,316
Humane society	1	5	2,83	1,428
Freedom of speech	1	5	2,01	1,216

Differences are significant for stable economy (Friedman $\chi^2=12,34$, $df=1$, $Asym.Sig.=0,00$) and for freedom of speech (Friedman $\chi^2=4,17$, $df=1$, $Asym.Sig.=0,04$).

There is a correlation between opinion about the importance of clean and healthy environment and age, where older respondents rank it higher than younger respondents do. (Spearman's $\rho=0,112$, $Sig.(2-tailed)=0,036$, $N=352$)

Another correlation occurs between opinion about importance of economic growth and age, where younger respondents rank it higher than older respondents do. (Spearman's $\rho=-0,156$, $Sig.(2-tailed)=0,003$, $N=352$)

Results aggregation

Respondents were asked about their opinion on the importance of a clean and healthy environment, stable economy, economic growth, humane society, and freedom of speech and no significant difference between employees and respondents from general population was found. The Influence of extraneous variables was identified, since significant differences occur among respondents of different age on all issues except a stable economy and influence of employment on the opinion on economic growth. It is interesting that the opinion on importance of a stable economy reduced significantly between surveys, whereas opinion on the importance of freedom of speech rose during this time. Results are similar for both groups.

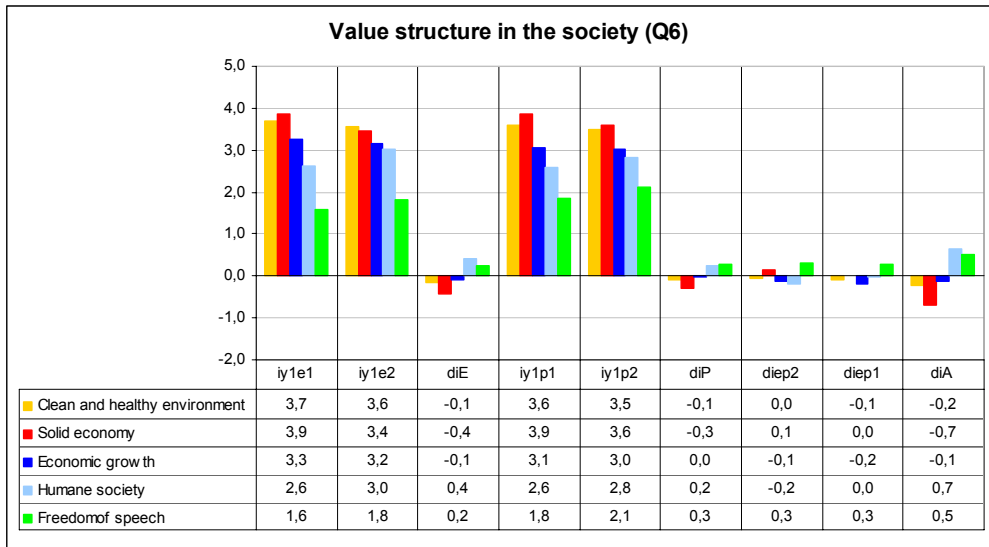

- $y_{(3-6)e}^1$ - sample mean result for employees (e) in the 1st survey (Graph: y3e1)
- $y_{(3-6)e}^2$ - sample mean result for employees (e) in the 2nd survey (Graph: y3e2)
- $y_{(3-6)p}^1$ - sample mean result for general population (p) in the 1st survey (Graph: y3p1)
- $y_{(3-6)p}^2$ - sample mean result for general population (p) in the 2nd survey (Graph: y3p2)
- 3-6 - index, marking partial results for variable Y3, represented by result from the question Q-6
- $\Delta E_{(3)}$ - difference between 1st and 2nd survey results for employees (Graph: dE3)
- $\Delta P_{(3)}$ - difference between 1st and 2nd survey results for general population (Graph: dP3)
- $\Delta ep_{(3)}^1$ - difference in 1st survey between employees and general population (Graph: dep1)
- $\Delta ep_{(3)}^2$ - difference in 2nd survey between employees and general population (Graph: dep2)
- $\Delta A_{(3)}$ - common difference for both groups in both surveys (Graph: dA3)

Graph A4/ 34: Value structure on which society currently depends

Value structure of the society (Q-6)

iY_3	$X_{i(=3-7)}$	X_1 / X_2	ΔA
Solid economy		PK / GP similar	1st / 2nd down
Clean and healthy environment	- age	PK / GP similar	1st / 2nd similar result
Economic growth	- employment - age	PK / GP similar	1st / 2nd similar result
Humane society	- age	PK / GP similar	1st / 2nd similar result
Freedom of speech	- age	PK / GP similar	1st / 2nd up

- iY_i - opinion on the subject
- $X_{i(=3-7)}$ - control variables (education, employment, gender, location)
- X_1/X_2 - general population/ employees
- PK / GP high/low - employees grade the option significantly different than general population
- 1st s. / 2nd s down - results of the 2nd survey are significantly lower than in the 1st survey
- 1st s. / 2nd s up - results of the 2nd survey are significantly higher than in the 1st survey

Graph A4/ 35: Significant differences – value structure on which society currently depends

A4/4 VARIABLE Y4: READINESS TO RISK MATERIAL SAFETY

Respondents were asked to rank their agreement with the statement: 'Environment has to be protected even if it means less jobs in local community' on a scale 1-4

1st survey

Table A 4/ 20

Readiness of the society to risk material safety in order to protect environment – frequency table of the 1st survey results (N=293)

Agreement 1

		Frequency	Percent	Valid Percent	Cumulative Percent
Valid	don't agree at all	7	1,8	2,4	2,4
	don't agree	56	14,6	19,1	21,5
	agree	172	44,9	58,7	80,2
	strongly agree	58	15,1	19,8	100,0
	Total	293	76,5	100,0	
Missing	System	0	,0		
Total		293	100,0		

78,5% of respondents agrees or strongly agrees with this statement. The mean respondents rank their agreement with the statement with 2,96 on the scale 1-4. The influence of employment shows an expected pattern, since students show the lowest agreement (mean=1,42) i.e. more concern for jobs, whereas retirees show the highest agreement with the statement (mean=3,05). According to the Kruskal Wallis test the influence of employment status is statistically significant. ($\chi^2=10,49$, $df=3$, Asymp. Sig. =0,015)

There is no influence of gender on this question (mean = 2,95-2,96). Some differences appear among respondents with a different level of education. The lowest ranking is given by students (mean=2,72), who are obviously more concerned about their future job opportunities. The highest rank is 3,20 for respondents with no education, but differences are not statistically significant.

The analysis according to location of residency shows, that respondents from Ankaran and Zg. Škofije show the highest level of agreement with the statement (mean=3,09). Employees of the Port of Koper show the lowest level of agreement with this statement (mean = 2,8). Differences are significant among opinions of respondents from Ankaran (mean=3,09) and City of Koper (mean=2,92). (Friedman $\chi^2=5,76$, $df=1$, Asymp. Sig. =0,016) and among opinions of residents from Zg. Škofije (mean=3,09) and employees of the Port of Koper (mean=2,78). (Friedman $\chi^2=4,5$, $df=1$, Asymp. Sig. =0,034)

Generally answers show a picture of respondents, who have a relatively high environmental conscience (mean=2,96 on the scale 1-4), which also means 78,5% of respondents agrees with the statement and that they are ready to protect the environment even if it means less jobs in the local community.

2nd Survey

82% of respondents agree or strongly agree with the statement, which is higher than in the 1st survey.

Respondents in the second survey rank their agreement with the statement by the mean value of 3,06 on a scale of 1-4. Employed respondents grade the statement higher (mean=3,05) than unemployed (mean=2,9), but the difference is not statistically significant. There is very little difference among genders or among groups with different education. Analysis of respondents according to their age shows that the lowest agreement with the statement is among younger respondents (18-25 years, mean=2,92 and 26-35 years, mean=2,90). Correlation between the level of agreement and age is significant. (Spearman's $\rho = 1,06$, sig(2-tailed)=0,039).

Table A 4/ 21

Readiness of the society to risk material safety in order to protect environment – frequency tale of the 2nd survey results (N=383)

		Frequency	Percent	Valid Percent	Cumulative Percent
Valid	don't agree at all	7	1,8	1,9	1,9
	don't agree	61	15,9	16,2	18,0
	agree	210	54,8	55,7	73,7
	strongly agree	99	25,8	26,3	100,0
	Total	377	98,4	100,0	
Missing	System	6	1,6		
Total		383	100,0		

Employees of the Port of Koper give this statement the lowest ranking (mean=2,80). Analysis according to location shows that respondents from Zg. Skofije (mean=3,0) and Ankaran (mean=3,0), show a lower level of agreement than other residents, but higher than employees of the Port. The Friedman test reveals that differences in opinion among respondents from different locations of residency and employees of the Port of Koper are significant (Friedman $\chi^2=17,3$, df=6, Asymp. Sig. =0,008)

Table A 4/ 22

Descriptive according to location of residency

	N	Minimum	Maximum	Mean	Std. Deviation
Ankaran	91	1	4	3,00	,715
Bertoki	28	2	4	3,39	,875
Hrvatini	32	2	4	3,28	,888
Koper	120	1	4	3,08	,700
Port of Koper	41	1	4	2,80	,641
Sp Skofije	43	1	4	3,14	,743
Zg Skofije	23	2	4	3,00	,522
Valid N (listwise)	23				

When we compare both surveys we see that respondents are more concerned about environmental protection than they were two years previously, but the difference is not significant.

Table A 4/ 23

Comparison of both surveys results / age

	2001	2003
18-25	2,8	2,9
26-35	2,9	2,9
36-45	3,1	3,1
46-55	2,9	3,1
56-65	2,9	3,1
66-75	3,1	3,2
76-	3,0	3,2

Results aggregation

The agreement with the statement 'Environment has to be protected even if it means less jobs in local community' ranked high in both surveys a fact that presents a picture of people, who express high a concern for environmental protection. The general population's agreement with the statement is higher in both surveys than that of the group of employees. The influence of the extraneous variables employment and age, was identified in the analysis. The difference between employees and the general population could be assigned to the different employment and gender structure of the group.

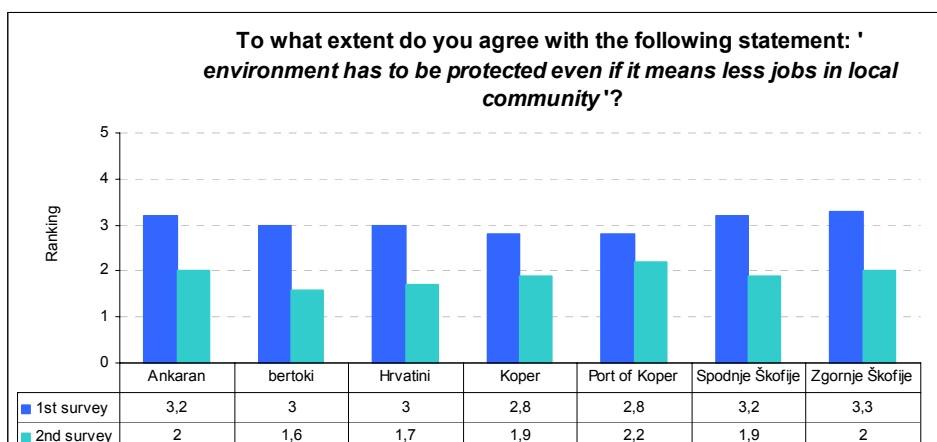

Graph A4/ 36: Comparison of results from both surveys according to residency

Table A 4/ 24
Differences between both surveys results

Test Statistics^c

	Agreement 2 - Agreement 1	PK Agreement 1 - Agreement 1	PK Agreement 2 - PK Agreement 1	PK Agreement 2 - Agreement 2
Z	-11,375 ^a	-2,559 ^a	-3,054 ^a	-1,477 ^b
Asymp. Sig. (2-tailed)	,000	,010	,002	,140

a. Based on positive ranks.

b. Based on negative ranks.

c. Wilcoxon Signed Ranks Test

A 4/5 VARIABLE Y5: PERCEPTION OF ENVIROMENTAL ISSUES

A 4/ 4.5.1 Air pollution

Respondents were asked in question Q-8 to rank the most important sources of **air pollution** in the coastal area on the scale 1-5. They had following choices:

- agriculture
- waste and waste sites
- industry
- tourism
- Port of Koper
- road traffic
- individual fire places
- I do not know

1st survey

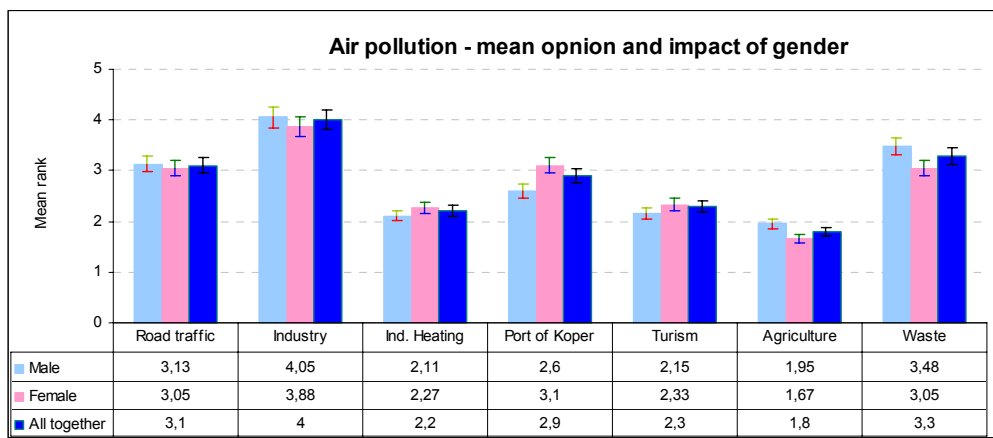

Graph A4/ 37: Air pollution sources – descriptive data of the 1st survey results

Respondents graded Industry as the most important contributor to air pollution (mean = 3,97), then Waste and waste treatment with the mean=3,28, road traffic (mean=3,09), Port of Koper (mean =2,85) and Tourism (mean=2,23). Respondents consider agriculture as least important source of air pollution (mean = 1,82).

Kruskal-Wallis Test – influence of gender and education structure on the results:

Table A 4/ 25
Influence of gender and education groups structure on results

	Gender	N	Mean Rank
Waste and waste treatment	male	132	135,22
	female	116	112,30
	Total	248	
Port of Koper	male	129	111,42
	female	119	138,68
	Total	248	

	Waste and waste treatment	Port of Koper
Chi-Square	6,637	9,351
df	1	1
Asymp. Sig.	,010	,002

a. Kruskal Wallis Test
b. Grouping Variable: Gender

	Employment	N	Mean Rank
Waste and waste treatment	employed	137	122,35
	non-employed	35	134,19
	retired	60	130,56
	m-student	13	68,54
	u-student	2	222,50
Total		247	

	Waste and waste treatment
Chi-Square	13,598
df	4
Asymp. Sig.	,009

a. Kruskal Wallis Test
b. Grouping Variable: Employment

A correlation occurs in analysis of questions between:

- the impact of waste and waste sites on air pollution / according to gender. (Spearman's $\rho = -$

0,164, sig (2-tailed) = 0,01, n=248) Female respondents grade this impact significantly lower (mean=3,06) than male respondents (mean=3,48). (Kruskal Wallis $\chi^2=6,63$, df=1, Asymp. Sig. =0,01);

- respondents with different employment status, where students at the university grade this impact the highest (mean=5), whether high-school students grade it the lowest (mean=2,31) (Kruskal Wallis $\chi^2=13,59$, df=4, Asymp. Sig. =0,009)
- analysis of question about the impact of Port of Koper on air pollution / according to gender (Spearman's $\rho=0,195$, sig (2-tailed) = 0,002, n=248), where female respondents grade this impact significantly higher (mean=3,12) than male respondents (mean=2,60). (Kruskal Wallis $\chi^2=9,351$, df=1, Asymp. Sig. =0,002)
- opinion of respondents from Ankaran on the impact of tourism (mean=2,47) differs significantly from opinion of residents from City of Koper (mean=2,05) (Friedman $\chi^2=4,0$, df=1, Asymp. Sig. =0,046)

opinion about the impact of Port of Koper among respondents from different locations and employees of the Port, but differences are not statistically significant. Respondents from City of Koper (mean=2,57) and Port of Koper (mean=2,46) grade Port's impact lower than other respondents (mean = 2,85-3,32), but differences are not statistically significant. (Table E-68)

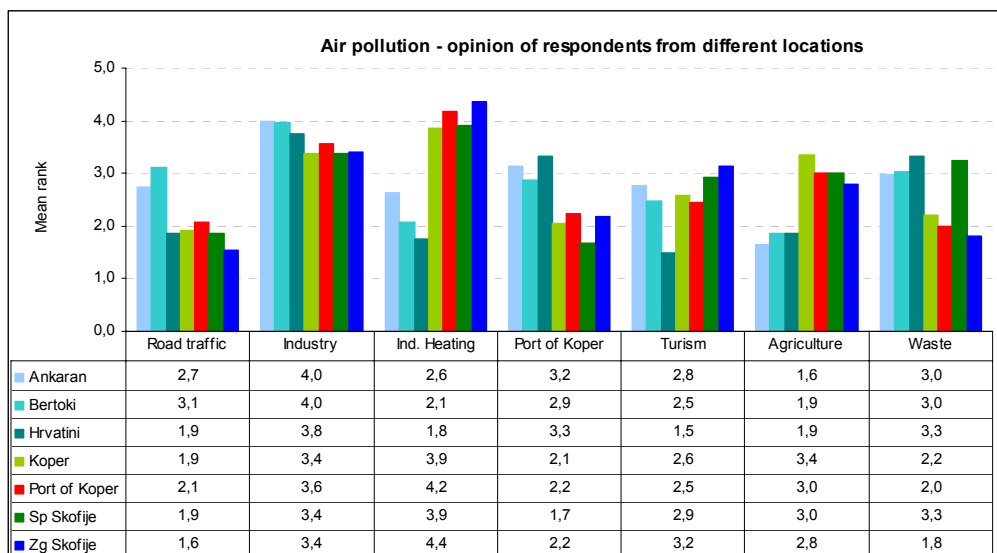

Graph A4/ 38: Influence of Port of Koper on air pollution – descriptive data of the 1st survey results

2.nd survey

Results of both surveys are very similar and in there are no significant differences in the common group of respondents.

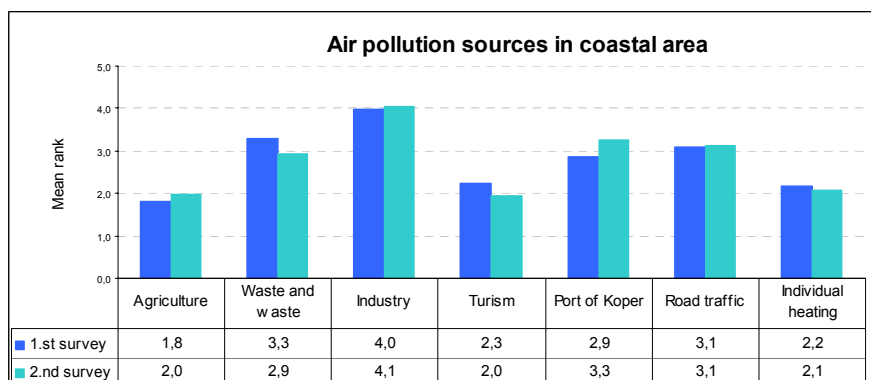

Graph A4/ 39: Air pollution source – descriptive data of the 1st and 2nd survey results

There are differences in opinions between both surveys. Respondents from Ankara, who grade the Port's impact on air quality significantly higher (mean=3,84) in the 2nd survey than in the 1st survey (mean=3,15) (Friedman $\chi^2=8,76$, df=1, Asymp.Sig.= 0,003).

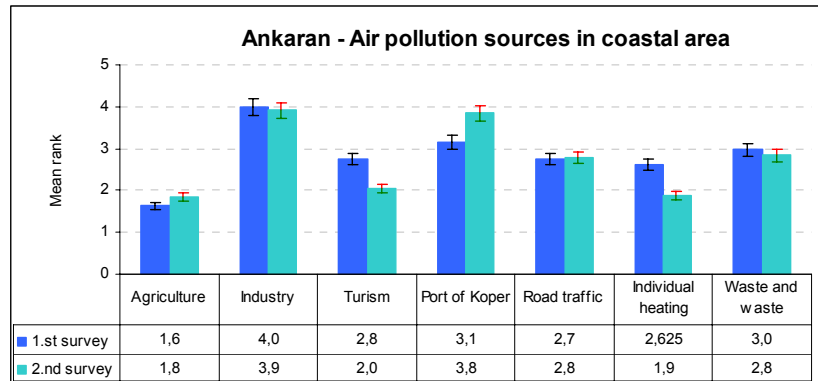

Graph A4/ 40: Air pollution source – descriptive data of 1st and 2nd survey results - Ankara

A significant difference occurs between both surveys between respondents' from the City of Koper opinion of the influence on air pollution by waste and waste treatment (mean1=3,39, mean2=2,9) (Friedman $\chi^2=8,34$, df=1, Asymp.Sig.= 0,004) and the Port of Koper (mean1=2,57, mean2=3,06) (Friedman $\chi^2=4,89$, df=1, Asymp.Sig.= 0,027).

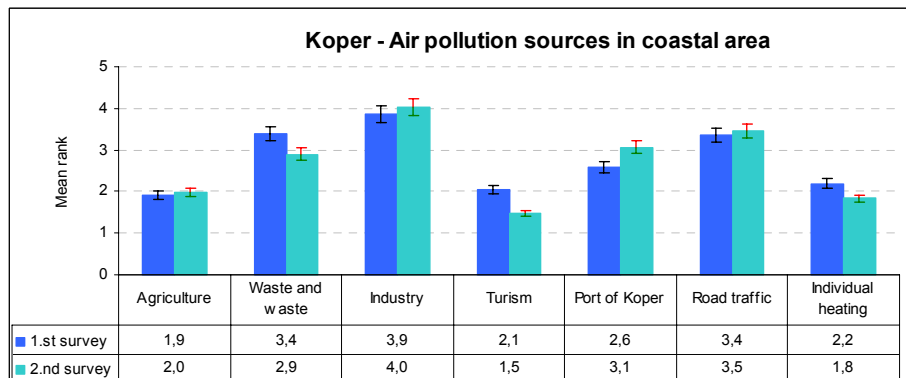

Graph A4/ 41: Air pollution source – descriptive data of the 1st and 2nd survey results - Koper

Results aggregation

There is no consistent and significant influence of extraneous variables (gender, age, employment, and education) on the opinion of air pollution in the coastal area.

There are significant differences between employees and respondents from the general population opinions of influence of road traffic on air pollution in both surveys and about the influence of Port of Koper in the 2nd survey. Respondents from the general population grade influence of the Port higher than Port employees do, whereas respondents from the group of employees grade the influence of road traffic higher than respondents from general population do.

Air pollution in coastal area (Q-8)

iY_i	$X_{i(i=3-7)}$	X_1 / X_2	$\Delta\Delta$
Industry	Location of residency	PK / GP similar result	1st / 2nd similar result
Waste and waste sites		PK / GP more / lesse	1st / 2nd down
Road traffic		PK / GP more / less	1st / 2nd PK up
Port of Koper	Location of residency	PK / GP less / more	1st / 2nd PK down / GP up
Tourism		PK / GP similar result	1st / 2nd similar result
Individual fireplaces		PK / GP similar result	1st / 2nd similar result
Agriculture		PK / GP similar result	1st / 2nd similar

- iY_i - opinion on the subject
- $X_{i(i=3-7)}$ - control variables (education, employment, gender, location)
- X_1/X_2 - general population/ employees

- PK / GP high/low - employees grade the option significantly different than general population
- 1st s. / 2nd s down - results of the 2nd survey are significantly lower than in the 1st survey
- 1st s. / 2nd s up - results of the 2nd survey are significantly higher than in the 1st survey

Graph A4/ 42: Significant differences – air pollution

Comparison of the 1st and 2nd survey results : Wilcoxon Signed Rank Test- Respondents: General population

Table A 4/ 26
Wilcoxon Signed Rank Test - general populations' opinion

Test Statistics^c

	Agriculture 2 - Agriculture 1	Waste and waste treatment 2 - Waste and waste treatment 1	Industry 2 - Industry 1	Turism 2 - Turism 1	Port of Koper 2 - Port of Koper 1	Road traffic 2 - Road traffic 1	Individual heating 2 - Individual heating 1
Z	-1,063 ^a	-2,707 ^a	-1,027 ^b	-1,906 ^a	-4,800 ^b	-,387 ^a	-,585 ^a
Asymp. Sig. (2-tailed)	,288	,007	,304	,057	,000	,699	,559

- a. Based on positive ranks.
- b. Based on negative ranks.
- c. Wilcoxon Signed Ranks Test

Comparison of the 1st and 2nd survey results : Wilcoxon Signed Rank Test- Respondents: Employees of the Port

Table A 4/ 27
Wilcoxon Signed Rank Test- Employees opinion

Test Statistics^c

	PK Agriculture 2 - PK Agriculture 1	PK Waste and waste treatment 2 - PK Waste and waste treatment 1	PK Industry 2 - PK Industry 1	PK Turism 2 - PK Turism 1	PK Port of Koper 2 - PK Port of Koper 1	PK Road traffic 2 - PK Road traffic 1	PK Individual heating 2 - PK Individual heating 1
Z	-,948 ^a	-,509 ^a	-,790 ^a	-1,000 ^a	-1,632 ^a	-2,164 ^b	-1,342 ^b
Asymp. Sig. (2-tailed)	,343	,611	,429	,317	,103	,030	,180

- a. Based on positive ranks.
- b. Based on negative ranks.
- c. Wilcoxon Signed Ranks Test

Comparison of the general population group with the employees group in the 1st survey:

Table A 4/ 28

Wilcoxon Signed Rank Test- Comparison of general population group to employees - 1st survey

Test Statistics ^c							
	PK Agriculture 1 - Agriculture 1	PK Waste and waste treatment 1 - Waste and waste treatment 1	PK Industry 1 - Industry 1	PK Turism 1 - Turism 1	PK Port of Koper 1 - Port of Koper 1	PK Road traffic 1 - Road traffic 1	Individual heating 1 - Individual heating 1
Z	-,136 ^a	-1,351 ^a	-,736 ^a	-1,997 ^b	-1,889 ^b	-2,080 ^a	-1,656 ^b
Asymp. Sig. (2-tailed)	,892	,177	,462	,046	,059	,038	,098

a. Based on negative ranks.

b. Based on positive ranks.

c. Wilcoxon Signed Ranks Test

Comparison of the general population group with the employees respondents group in 2nd survey:

Table A 4/ 29

Wilcoxon Signed Rank Test- Comparison of general population group to employees - 2nd survey

Test Statistics ^d							
	PK Agriculture 2 - Agriculture 2	PK Waste and waste treatment 2 - Waste and waste treatment 2	PK Industry 2 - Industry 2	PK Turism 2 - Turism 2	PK Port of Koper 2 - Port of Koper 2	PK Road traffic 2 - Road traffic 2	PK Individual heating 2 - Individual heating 2
Z	,000 ^a	-1,835 ^b	-,438 ^b	-1,633 ^c	-3,819 ^c	-3,083 ^b	-1,510 ^b
Asymp. Sig. (2-tailed)	1,000	,067	,661	,102	,000	,002	,131

a. The sum of negative ranks equals the sum of positive ranks.

b. Based on negative ranks.

c. Based on positive ranks.

d. Wilcoxon Signed Ranks Test

Comparison of survey results to expert data

All groups of respondents rank Road traffic very low. One possible reason is that they added the impact of road traffic to the impact of industry, tourism or the Port of Koper. Another reason for giving the influence of road traffic a low ranking might be the fact that everybody is used to it and contributes to it. Respondents grade the impact of traffic highest at the age of 46-55 in cumulative analysis.

Industry and the Port of Koper as sources of air pollution are graded similarly as suggested ranking for all groups except for comparison according to location of residency, which shows that respondents in Hrvatini, Ankaran and Bertoki grade the influence of the Port higher than respondents from other locations.

Air pollution ranking according to severity and probability of present level of pollution, hazardous potential (worst case scenario, accidents), presence of continuous impacts, bioaccumulation hazard, toxicity hazard, potential harmful impact on human health and potential harmful impact on ecosystem.

Table A 4/ 30
 Ranking of environmental impacts – air pollution

	Present level of pollution		Hazardous potential (worst case scenario, accidents)		Presence of continuous impacts		Bioaccumulation hazard		Toxicity hazard		Potential harmful impact on human health		Potential harmful impact on ecosystem		Ranking
	S	P	S	P	S	P	S	P	S	P	S	P	S	P	
Agriculture	4	4	1	1	3	4	2	2	2	1	2	2	2	2	2,9
Waste treatment	3	3	3	2	3	3	3	3	4	3	2	2	2	2	3,4
Industry	4	4	1	1	3	4	2	2	2	1	2	2	2	2	2,9
Tourism	4	4	3	3	3	4	4	4	4	3	3	3	4	3	4,4
Port of Koper	4	3	4	3	3	4	2	3	4	2	4	3	4	3	4,1
Road traffic	4	4	4	3	3	4	3	4	4	2	4	3	4	3	4,4
Individual heating	3	3	1	1	3	3	2	3	2	1	2	1	2	1	2,5

Severity (S)		Probability for damage to human health or ecosystems (P)	
Catastrophic impact	4	High (happens often)	4
Medium impact	3	Medium (can happen)	3
Small impact	2	Low (can happen in similar industries)	2
No impact	1	Very low (not likely to happen)	1

Table A 4/ 31 Ranking of environmental impacts – air pollution

A 4/ 4.5.2 Marine pollution

Respondents were asked in question Q-9 to rank the most important sources of marine pollution in the coastal area on the scale 1-5.

1.st survey

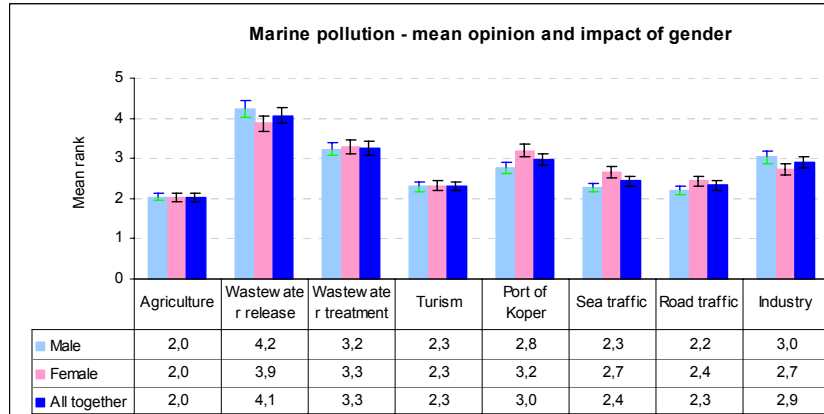

Graph A4/ 43: Marine pollution sources – descriptive data of the 1st survey results

Cumulative results show that respondents grade illegal outflows of wastewater as the most important source of marine pollution (mean = 4,07). The second source is the discharge from wastewater treatment plants (mean=3,25) and the third is the Port of Koper (mean=2,97). Outflow of wastewater from industrial sources with the mean=2,90 is the fourth most important source while Sea traffic is in sixth place (mean=2,44). This is followed by road traffic (mean=2,33), tourism (mean=2,31) and finally agriculture (mean=2,03).

A Correlation can be found between importance of agriculture by and employment status. (Spearman's $\rho = -0,221$, sig(2-tailed)=0,038). Employed respondents rate influence of agriculture higher (mean=2,2) than unemployed, retired respondents or students (mean=1,80)

Wastewater release influence and gender also show a correlation with male respondents grading illegal outflows higher (mean = 4,24) than female respondents (mean = 3,89). (Spearman's $\rho = -0,140$, sig(2-tailed)=0,024) The Kruskal Wallis test shows, that the difference in opinions of male and female group is significant. (Kruskal Wallis $\chi^2=5,09$, df=1, Asymp. Sig. =0,024). Some differences in opinion exist also among respondents from different locations and employees of the Port of Koper, but these are not significant.

A correlation exists between opinions expressed about the influence that the Port of Koper has on marine quality and gender, where male respondents rate its influence lower (mean=2,76) than female group (mean=3,18) (Spearman's $\rho = 0,155$, sig(2-tailed)=0,019). The Kruskal Wallis test shows, that the difference in opinions of male and female group is significant. (Kruskal Wallis $\chi^2=5,44$, df=1, Asymp. Sig. =0,020)

A difference occurs in the analysis of opinions of respondents from different locations, where respondents from Ankarana grade the influence of Port of Koper much higher than others (mean=3,79) while employees of the Port of Koper grade it's much lower (mean=2,52). These differences are however not statistically significant. (Friedman $\chi^2=2,0$, df=1, Asymp. Sig. =0,157)

2.nd survey

Results of the second survey are very similar to the first one. The Kruskal Wallis test shows that there is significant difference in the opinions of male and female respondents concerning the influence of the Port of Koper. Female respondents grade it significantly higher (mean=3,09) than male respondents (mean=2,74) ($\chi^2=4,22$, $df=1$, $Asymp.Sig.=0,04$, $N=299$)

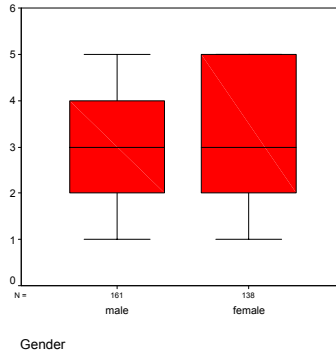

Graph A4/ 44: Impact of port of Koper on marine quality – influence of gender

Results aggregation

Cumulative results of both surveys in the questions on **marine pollution** show that opinion about influence of Port of Koper on marine quality and gender correlate i.e., female respondents grade it significantly higher than male respondents do. There is a significant difference between both groups in both surveys on opinion about the Port of Koper impact, where respondents from the general population grade it significantly higher than group of employees. The different gender structure of the respondents is thought to be one reason for the big differences observed in the opinions of the general population and employees of the Port.

Marine water pollution in coastal area (Q-9)

Y_i	$X_{i(=3-7)}$	X_1 / X_2	ΔA
Wastewater release	- gender	PK / GP more/less	1st / 2nd similar result
WW treatment		PK / GP similar result	1st / 2nd similar result
Port of Koper	- gender - location	PK / GP less / more	1st / 2nd similar
Sea traffic		PK / GP similar result	1st / 2nd similar result
Tourism		PK / GP similar result	1st / 2nd similar result
Road traffic		PK / GP similar result	1st / 2nd similar result
Agriculture	- employment	PK / GP similar	1st / 2nd similar result

- Y_i - opinion on the subject
- $X_{i(=3-7)}$ - control variables (education, employment, gender, location)
- X_1/X_2 - general population/ employees
- PK / GP high/low - employees grade the option significantly different than general population
- 1st s. / 2nd s down - results of the 2nd survey are significantly lower than in the 1st survey
- 1st s. / 2nd s up - results of the 2nd survey are significantly higher than in the 1st survey

Graph A4/ 45: Significant differences – the extent of knowledge about the environmental problems in coastal area – marine pollution

Comparison of survey results to expert data

Generally, people grade the influence of the discharge from wastewater treatment plants too low, since WWTP in the area do not have a secondary or even tertiary treatment. The influence of sea traffic is also ranked too low, despite contributing to alien species introduction, hydrocarbons pollution and in itself presents a big environmental risk. Influence of agriculture on

marine is also underestimated, since there are many acres of agricultural land in the coastal area (vineyards), which contribute to outflow of nutrients and pesticides.

Tourism is also graded relatively low, probably because people are involved in these activities and are used to them. There are three large marinas in the area, which contribute substantially to marine pollution.

Marine pollution ranking according to severity and probability of present level of pollution, hazardous potential (worst case scenario, accidents), presence of continuous impacts, bioaccumulation hazard, toxicity hazard, potential harmful impact on human health and potential harmful impact on ecosystem.

Table A 4/ 32
Ranking of environmental impacts – marine pollution

	Present level of pollution		Hazardous potential (worst case scenario, accidents)		Presence of continuous impacts		Bioaccumulation hazard		Toxicity hazard		Potential harmful impact on human health		Potential harmful impact on ecosystem		Rank
	S	P	S	P	S	P	S	P	S	P	S	P	S	P	
Agriculture	3	3	3	2	3	2	3	4	3	2	2	2	3	3	3,4
Illegal wastewater release	3	3	2	3	2	4	4	3	3	2	4	3	4	3	3,8
Wastewater treatment	3	3	2	3	2	4	4	3	3	2	4	3	4	3	3,8
Industry	2	2	2	1	1	2	2	2	2	2	2	1	2	2	2,2
Tourism	3	3	3	2	3	3	3	4	4	2	4	3	4	3	3,9
Port of Koper	3	3	3	3	2	3	2	3	2	3	1	1	3	3	3,1
Marine traffic	2	3	4	3	3	4	4	4	4	2	4	2	4	4	4,2
Road traffic	2	2	1	1	2	1	1	2	1	1	1	1	1	1	1,6

Severity (S)		Probability for damage to human health or ecosystems (P)	
Catastrophic impact	4	High (happens often)	4
Medium impact	3	Medium (can happen)	3
Small impact	2	Low (can happen in similar industries)	2
No impact	1	Very low (not likely to happen)	1

A 4/ 4.5.3 Noise pollution

Respondents were asked in question Q-10 to rank the most important sources of noise generation in the coastal area on the scale 1-5.

1st survey

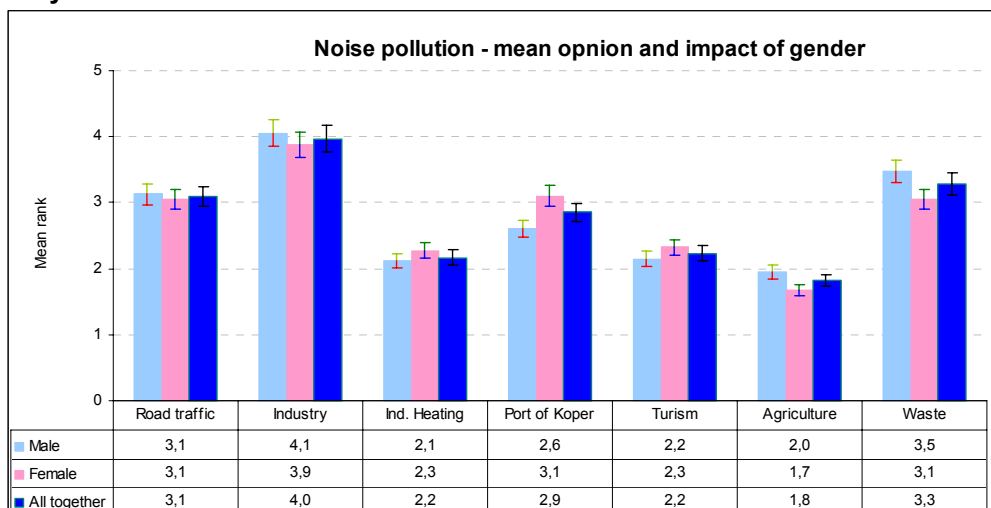

Graph A4/ 46: Sources of noise generation – descriptive data of the 1st survey

The most important source of noise is considered to be road traffic (mean=4,51). The second most is the Port of Koper (mean=3,19), followed by Industry (mean =3,14) then tourism (mean =2,46) and finally agriculture (mean=1,74).

A Comparison of the different groups and correlation among them shows, that opinion on influence of road traffic is correlated to employment status of respondents. (Spearman's $\rho=0,148$, sig(2-tailed)=0,022) Analysis shows that students and retired respondents grade road traffic noise higher than employed and non-employed respondents.

More differences occur between respondents with different location of residency.

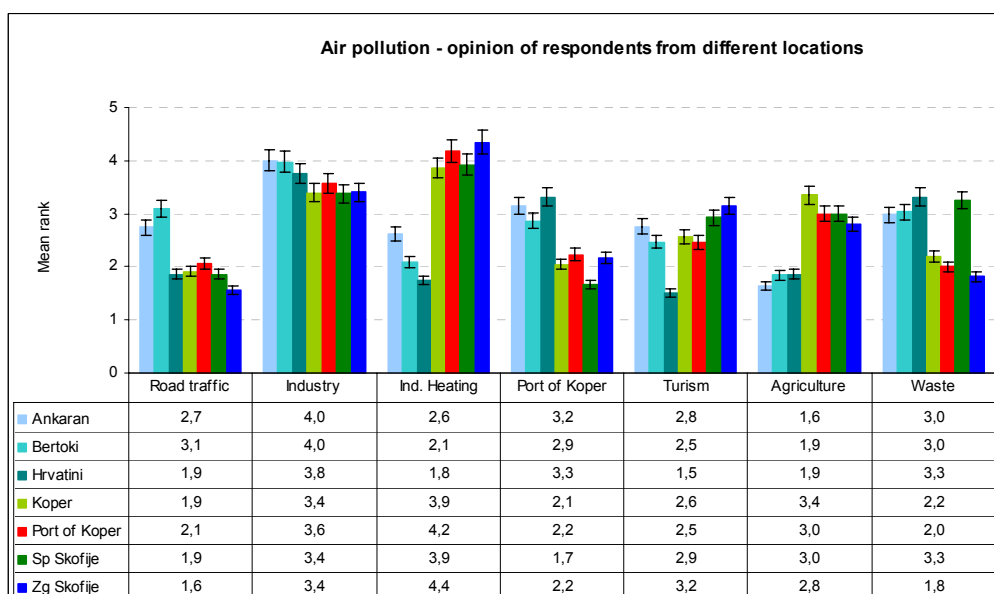

Graph A4/ 47: Sources of noise generation – respondents from different locations of residency

Respondents from Ankaran (mean=2,76) grade the impact of *tourism* on noise significantly

higher than Respondents from Bertoki (Friedman $\chi^2=8,00$, $df=1$, Asymp. sig. = 0,005) and the City of Koper (Friedman $\chi^2=4,17$, $df=1$, Asymp. sig. = 0,041).

Respondents from Ankaran grade the impact of *industry* on noise pollution significantly lower than other respondents do and significant difference occur between Ankaran and Bertoki (mean=3,40, Friedman $\chi^2=5,261$, $df=1$, Asymp. sig. = 0,022), employees of the Port of Koper (mean=3,35, Friedman $\chi^2=4,765$, $df=1$, Asymp. sig. = 0,029), Sp. Škofije (mean=4,5, Friedman $\chi^2=4,5$, $df=1$, Asymp. sig. = 0,034) and Zg. Škofije (mean=3,14, Friedman $\chi^2=9,308$, $df=1$, Asymp. sig. = 0,002). Respondents from Hrvatini (mean=2,69) also grade the impact of industry on noise significantly lower than respondents from Bertoki (mean = 3,40, Friedman $\chi^2=4,765$, $df=1$, Asymp. sig. = 0,029) and Koper (mean=3,18, Friedman $\chi^2=5,333$, $df=1$, Asymp. sig. = 0,021).

Impact of *agriculture* is also graded differently In the second survey. Respondents from the city of Koper (mean = 1,49) and Port of Koper (mean=1,42) grade the impact of agriculture on noise generation much lower than respondents from other locations; this observable difference is only significant among opinions of respondents from Koper and Ankaran (mean=2,26, Friedman $\chi^2=6,545$, $df=1$, Asymp. sig. = 0,11), Sp. Škofije (mean=1,86, Friedman $\chi^2=4,0$, $df=1$, Asymp. sig. = 0,046) and Zg. Škofije (mean=1,78, Friedman $\chi^2=4,5$, $df=1$, Asymp. sig. = 0,034).

Respondents from Ankaran grade the impact of *road traffic* significantly lower than respondents from other locations: Bertoki (mean=4,79, Friedman $\chi^2=6,368$, $df=1$, Asymp. sig. = 0,012), City of Koper , (mean= 4,48, Friedman $\chi^2=10,714$, $df=1$, Asymp. sig. = 0,001), Port of Koper (mean=4,74, Friedman $\chi^2=5,556$, $df=1$, Asymp. sig. = 0,018) and Zg. Škofije (mean=4,51, Friedman $\chi^2=4,5$, $df=1$, Asymp. sig. = 0,034).

Employees of the Port of Koper grade the impact of *Port of Koper* activities on noise generation much lower than respondents from other locations (mean=2,48). The difference is significant for respondents from Ankaran (mean=3,57, Friedman $\chi^2=8,048$, $df=1$, Asymp. sig. = 0,005), Bertoki (mean=3,37, Friedman $\chi^2=4,571$ $df=1$, Asymp. sig. = 0,033), Hrvatini (mean=3,64, Friedman $\chi^2=4,263$ $df=1$, Asymp. sig. = 0,039) and Koper (mean=3,09, Friedman $\chi^2=5,0$ $df=1$, Asymp. sig. = 0,025). A comparison of respondent's opinion about the influence of Port of Koper has on noise pollution according to residency and employees:

Table A 4/ 33
Wilcoxon Signed Rank Test: Sources of noise generation by Port of Koper – respondents from different locations of residency and group of employees

Test Statistics ^b								
	Koper - Ankaran	Port of Koper - Ankaran	Sp Skofije - Ankaran	Port of Koper - Bertoki	Port of Koper - Hrvatini	Port of Koper - Koper	Sp Skofije - Hrvatini	Sp Skofije - Koper
Z	-3,009 ^a	-3,713 ^a	-3,766 ^a	-3,328 ^a	-2,215 ^a	-2,384 ^a	-2,425 ^a	-2,209 ^a
Asymp. Sig. (2-tailed)	,003	,000	,000	,001	,027	,017	,015	,027

a. Based on positive ranks.

b. Wilcoxon Signed Ranks Test

Comparison of respondents opinion about influence of road traffic on noise pollution according to location of residency and employees:

Table A 4/ 34
Wilcoxon Signed Rank Test: Sources of noise generation by road traffic – respondents from different locations of residency and group of employees

Test Statistics ^b				
	Bertoki - Ankaran	Hrvatini - Ankaran	Koper - Ankaran	Port of Koper - Ankaran
Z	-2,514 ^a	-2,543 ^a	-3,684 ^a	-3,556 ^a
Asymp. Sig. (2-tailed)	,012	,011	,000	,000

a. Based on negative ranks.

b. Wilcoxon Signed Ranks Test

2nd survey

Results of both surveys are similar, which shows also in a comparison of both the surveys:

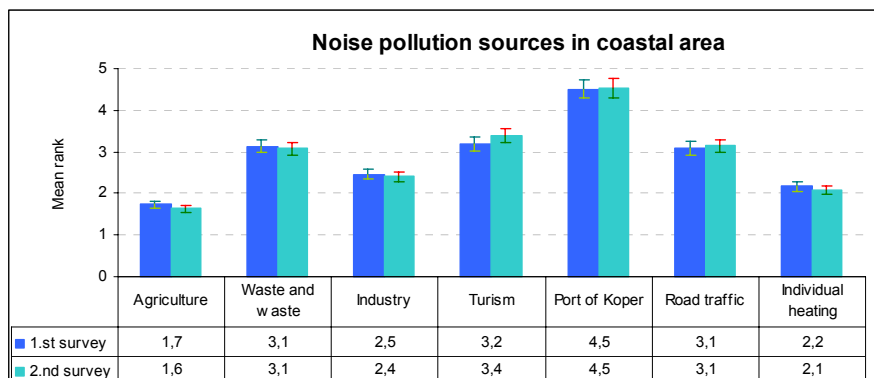

Graph A4/ 48: Sources of noise generation – comparison of both surveys

Results aggregation

There are differences in opinions of both groups about *noise pollution*, where respondents from the group of employees grade road traffic and industry significantly higher and the influence of Port of Koper significantly lower than respondents from general population.

Noise pollution ranking according to severity and probability of present level of pollution and presence of continuous impacts.

Table A 4/ 35
Ranking of noise pollution sources

	Present level of pollution		Presence of continuous impacts		Ranking (*)
	Severity	Probability	Severity	Probability	
Agriculture	3	2	3	2	3,1
Industry	2	2	3	2	2,8
Tourism	4	3	4	3	4,4
Port of Koper	4	3	4	4	4,7
Road traffic	4	4	4	4	5,0

(*)- calculation: $\Sigma(\text{ranks}/\text{number of marks}) \cdot 5/4$

A 4/ 4.5.4 Risk to human health from environmental factors

Respondents were asked to rank risk to human health from the following environmental factors:

- air pollution
- water pollution
- soil pollution
- chemicals in food
- nuclear power plants
- radon in homes

1st survey

Table A 4/ 36
Risk to human health from environmental factors – descriptive data of the 1st survey results

Descriptive Statistics					
	N	Minimum	Maximum	Mean	Std. Deviation
Air pollution	288	1	4	2,94	,92
DN - air	5	1	1	1,00	,00
Water pollution	287	1	4	2,97	,85
DN-water	6	1	1	1,00	,00
Soil pollution	273	1	4	2,71	,84
DN-soil	20	1	1	1,00	,00
Chemicals in food	261	1	4	3,17	,80
DN-chemicals	32	1	1	1,00	,00
Nuclear power	232	1	4	2,02	1,01
DN-nuclear	62	1	1	1,00	,00
Radon in homes	145	1	4	2,18	,89
DN-radon	148	1	1	1,00	,00
Valid N (listwise)	0				

According to the cumulative results respondents consider chemicals in food as representing the highest risk to human health (mean=3,17). Second was the hazard posed by water pollution (mean=2,97) followed closely by air pollution (mean=2,94) and soil pollution (mean=2,71). Radon in homes is ranked fifth by respondents (mean=2,18) and nuclear power plants are considered to carry the smallest risk (mean=2,02).

There are some significant differences in the opinions expressed by the selected social groups on this subject. The most consistent is the difference in perception of risk between male and female respondents, since female respondents grade all risks higher than men do. Test show that a correlation exists between gender and air pollution (Spearman's = 0,171, sig(2-tailed)=0,004), water pollution (Spearman's = 0,137, sig(2-tailed)=0,02), soil pollution (Spearman's = 0,183, sig(2-tailed)=0,002) and nuclear power plant (Spearman's = 0,155, sig(2-tailed)=0,018).

There are also significant differences in the ranking of environmental risks according to male and female respondents. Female respondents grade significantly higher the following environmental threats:

- air pollution (mean_{fem}=3,1) (Kruskal Wallis Test: $\chi^2 = 7,372$; Asymp. sig. = 0,007)
- water pollution (mean_{fem}=3,09) (Kruskal Wallis Test: $\chi^2 = 6,22$; Asymp. sig. = 0,013)
- soil pollution (mean_{fem}=2,88) (Kruskal Wallis Test: $\chi^2 = 8,894$; Asymp. sig. = 0,003)
- nuclear power (mean_{fem}=2,19) (Kruskal Wallis Test: $\chi^2 = 5,156$; Asymp. sig. = 0,023)

Significant difference also occurs in the ranking of risk from air pollution and nuclear power plants according to education. Risk to human health from air pollution is graded highest by respondents with primary and no education (mean=3,20-3,23), students rank this risk with a mean=3,0, while respondents with a medium education rank the risk from air pollution with a mean=2,96 and respondents with high education by the mean=2,63. (Kruskal Wallis Test: $\chi^2 = 14,842$; Asymp. sig. = 0,011; nuclear power plants: Kruskal Wallis Test: $\chi^2 = 18,129$; Asymp. sig. = 0,003)

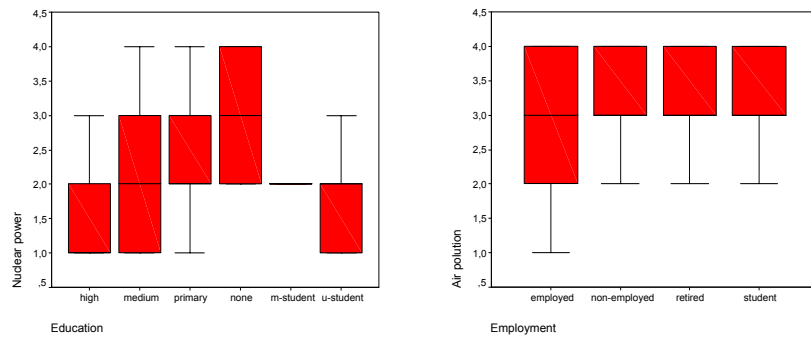

Graph A4/ 49: Risk to human health from nuclear power plants – influence of education and employment

A correlation can be found between employment status and risk from air pollution, where employed and non-employed respondents rank the risk from air pollution lower (mean = 2,81 - 2,97) than retired respondents or students (mean=3,13-3,21) (Spearman's $\rho=0,158$, sig(2-tailed)=0,007). A correlation occurs also between respondent's age and their opinion on radon in homes. (Spearman's $\rho=0,193$, sig(2-tailed)=0,02)

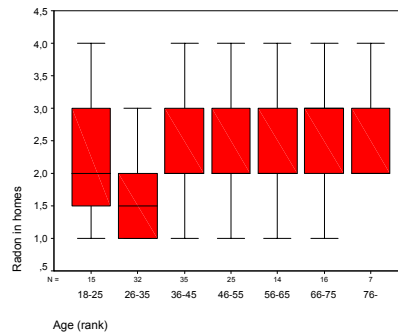

Graph A4/ 50: Risk to human health from radon in homes – influence of age

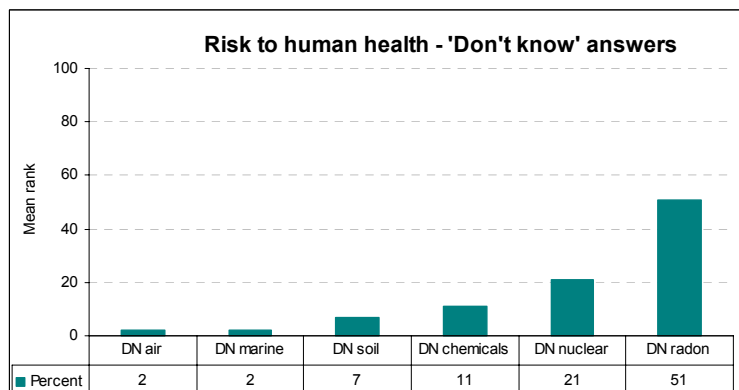

Graph A4/ 51: Risk to human health from radon in homes - 'don't know' answers

There is a significant difference in the opinions expressed by respondents from the general population to employees on the risk from the water pollution, where respondents from the general population (mean=3,03) grade it significantly higher than respondents from the group of employees (mean=2,53) (Wilcoxon Signed Ranks Test: $Z=-2,689$, Asymp. Sig. (2-tailed)=0,007) and on the risk from soil pollution, where respondents from general population (mean=2,79) grade it significantly higher than employees of the Port (mean=2,23) (Wilcoxon Signed Ranks Test: $Z=-3,551$, Asymp. Sig. (2-tailed)=0,000)

2.nd survey

Results of the 2nd survey are similar to the 1st survey. There is a significant difference in the opinions of respondents from the general population to those expressed by employees on the risk from the air pollution, where respondents from general population (mean=3,19) grade it significantly higher than respondents from the group of employees (mean=2,61) (Wilcoxon Signed Ranks Test: Z=-2,89, Asymp. Sig. (2-tailed)=0,004)

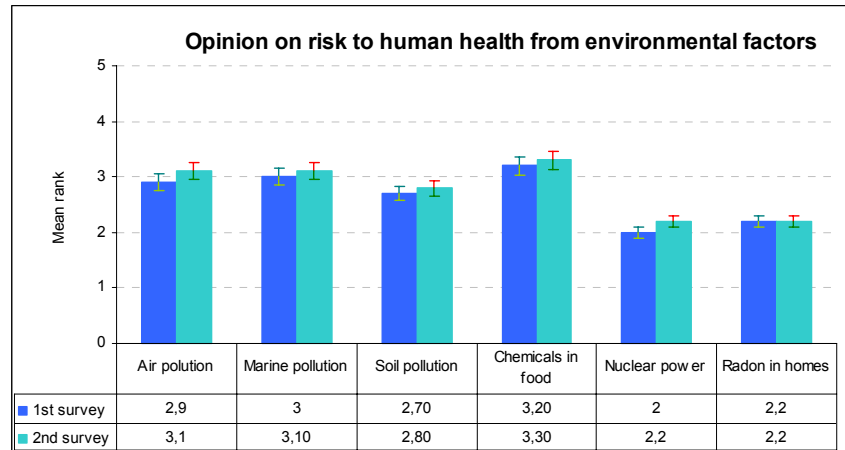

Graph A4/ 52: Risk to human health - comparison of results from both surveys – descriptive data (means)

Respondents ranked all risks higher in 2nd survey, but difference is not statistically significant.

Results aggregation

There are significant differences in ranking **risks to human health from** environmental factors among respondents of different gender, on all issues: female respondents rank all risks higher than male respondents. The influence of employment status was identified in the question about air pollution and the influence of age structure in the question concerning radon in homes. A comparison of the results of both groups shows, that employees grade all risks lower than the general population although only differences in opinion on air, water and soil pollution are significant. Some of these differences are due to different group gender structure. Respondents ranked all risks higher in the 2nd survey, although the differences are not statistically significant, except for air pollution, which is graded significantly higher in 2nd survey.

Risk to human health from environmental factors (Q-11/I, Q18/II)			
Y_s	$X_{i(i=3-7)}$	X_1 / X_2	ΔA
Chemicals in food	-Gender	PK / GP similar	1st / 2nd similar result
Water pollution	-Gender	PK / GP less/more	1st / 2nd similar result
Air pollution	-Gender -Employment	PK / GP less/more	1st / 2nd up
Soil pollution	-Gender	PK / GP less /more	1st / 2nd similar result
Radon in homes	-Gender -Age	PK / GP similar	1st / 2nd similar result
Nuclear power plant	-Gender	similar	1st / 2nd similar result

- Y_i - opinion on the subject
- $X_{i(i=3-7)}$ - control variables (education, employment, gender, location)
- X_1/X_2 - general population/ employees
- PK / GP high/low - employees grade the option significantly different than general population
- 1st s. / 2nd s down - results of the 2nd survey are significantly lower than in the 1st survey
- 1st s. / 2nd s up - results of the 2nd survey are significantly higher than in the 1st survey

Graph A4/ 53: Significant differences – risk to human health

A 4/6 VARIABLE Y6: OPINION ON THE PORT OF KOPER ENVIRONMENTAL IMPACTS

Respondents were asked in question Q-12 to rank the magnitude of environmental impact of the Port of Koper according to the following environmental factors:

- air pollution
- marine pollution
- soil pollution
- waste production
- noise generation
- alien species introduction
- storage of hazardous materials
- road accidents
- ship accidents
- rail accidents

1.st survey

Table A 4/ 37
Port of Koper environmental impact - descriptive data of the 1st survey

Descriptive Statistics					
	N	Minimum	Maximum	Mean	Std. Deviation
Air pollution	293	1	5	3,31	1,240
Water pollution	293	1	5	3,54	1,294
Soil pollution	293	1	5	2,77	1,196
Waste production	293	1	5	3,44	1,188
Noise generation	293	1	5	3,14	1,141
Indigenous spec. introd.	293	1	5	2,88	1,321
Storage of haz. mat.	293	1	5	3,56	1,353
Road accidents	292	1	5	3,35	1,304
Ship accidents	292	1	5	2,94	1,368
Rail accidents	291	1	5	2,95	1,328
Valid N (listwise)	291				

Respondents ranked storage of hazardous materials as the most important environmental concern (mean=3,56). In second place was marine pollution (mean=3,54), followed by waste production (mean=3,44), concern about road accidents(mean=3,35), air pollution (mean=3,31) and noise generation (mean=3,14). These six environmental concerns are ranked high on a scale 1-5. Rail accidents (mean=2,95) and shipping accidents (mean=2,94) are ranked lower and are viewed in a similar way, while Alien species introduction (mean =2,88) and soil pollution (mean=2,77) are not considered as a priority.

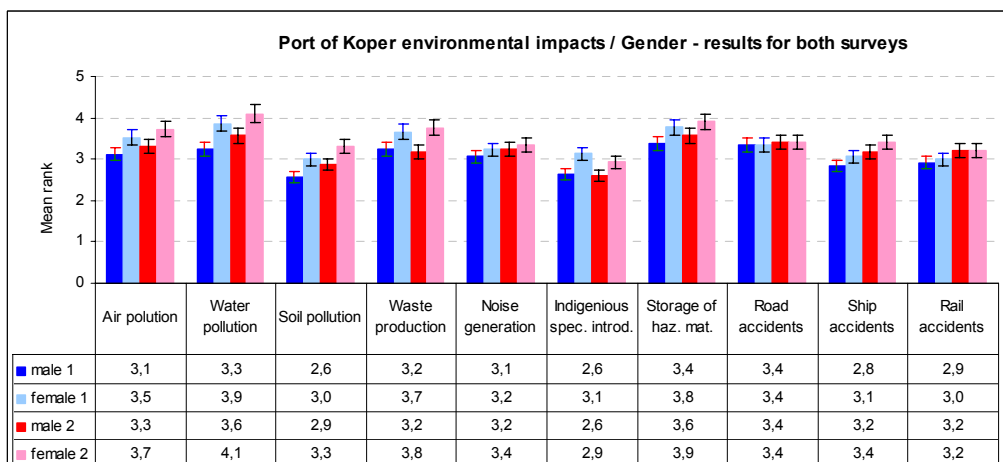

Graph A4/ 54: Magnitude of Port of Koper environmental impact - ex. variable: gender

There is a correlation between the opinions of respondents and gender, where female respondents grade the Port's environmental impact on air, marine and soil pollution, waste

production, alien species introduction and storage of hazardous materials significantly than male respondents (Spearman's $\rho = 0,78 - 0,530$, Sig. (2.tailed) = $0,0 - 0,006$). These differences in opinions among male and female respondents are significant in answers about air pollution, (Kruskal Wallis $\chi^2=8,219$; Asymp. Sig. = $0,004$), marine pollution (Kruskal Wallis $\chi^2=15,94$; Asymp. Sig. = $0,0000$), soil pollution (Kruskal Wallis $\chi^2=10,022$; Asymp. Sig. = $0,002$), marine production (Kruskal Wallis $\chi^2=9,261$; Asymp. Sig. = $0,002$), alien species introduction (Kruskal Wallis $\chi^2=8,946$; Asymp. Sig. = $0,003$) and impact due to the storage of hazardous materials (Kruskal Wallis $\chi^2=7,418$; Asymp. Sig. = $0,006$).

There is also a correlation between respondent's opinion on the Port's impact and on marine pollution and employment (Spearman's $\rho=-0,118$, sig(2-tailed)= $0,044$).

Significant differences also occur in the opinions expressed by retired respondents and students, where students are more concerned about impact of the Port on marine quality. (Kruskal Wallis $\chi^2=10,900$; Asymp. Sig. = $0,012$).

There is also a correlation between respondent's opinions on the Port's impact on marine pollution and age (Spearman's $\rho =-0,218$, sig(2-tailed)= $0,000$), where we observe that younger respondents express a higher level of concern than older groups. The difference is significant (Kruskal Wallis $\chi^2=15,413$; Asymp. Sig. = $0,017$).

Significant differences are found when analysing residency, including the Port employees. Employees in the Port of Koper have a significantly different opinion from other respondents on every question – they grade the magnitude of the Port's environmental impact lower than others. Respondents in Ankaran grade most of Port's influences significantly higher than other respondents do.

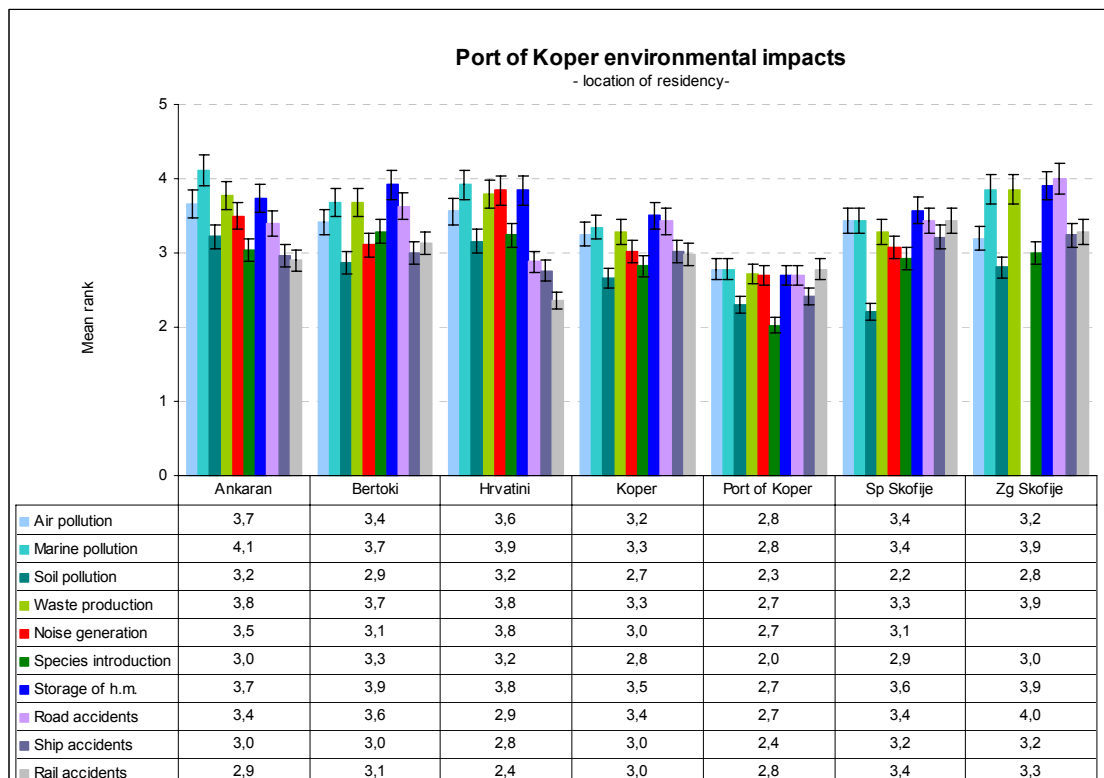

Graph A4/ 55: Port of Koper environmental impacts - ex. variable: location of residency

Some significant differences become apparent when comparing respondents' location with employees of the Port of Koper.

Employees of the Port (mean= $2,78$) grade the impact of the Port on *air pollution* significantly lower than respondents from Ankaran (mean= $3,66$) or from Hrvatini (mean= $3,56$), Friedman $\chi^2=6,675$, $df=1$, Asymp.sig.= $0,036$).

Employees of the Port (mean=2,78) grade the impact of the Port on *marine pollution* significantly lower than respondents from Ankaran (mean=4,12), Bertoki (mean=3,68), Hrvatini (mean=3,92) and Koper (mean=3,35), (Friedman $\chi^2=15,144$, df=3, Asym.sig.=0,004).

Employees of the Port (mean=2,72) grade the impact of the Port on *waste production* significantly lower than respondents from other locations (mean=3,28 – 3,86, (Friedman $\chi^2=15,959$, df=5, Asym.sig.=0,007).

Employees of the Port (mean=2,69) grade the impact of the Port on *noise pollution* significantly lower than respondents from other locations (mean=3,00 – 3,50, (Friedman $\chi^2=20,819$, df=6, Asym.sig.=0,002).

Employees of the Port (mean=2,03) and from Koper (mean=2,83), grade the impact of the Port on *alien species introduction* significantly lower than respondents from other locations (mean=2,93 – 3,29), (Friedman $\chi^2=20,819$, df=6, Asym.sig.=0,002).

Employees of the Port (mean=2,69), grade the risk from the *storage of hazardous materials* in the Port significantly lower than respondents from other locations (mean=3,50 – 3,92), (Friedman $\chi^2=10,744$, df=4, Asym.sig.=0,030).

Employees of the Port (mean=2,88), grade the risk from *road accidents* significantly lower than respondents from other locations (mean=3,40 – 4,00), (Friedman $\chi^2=11,827$, df=4, Asym.sig.=0,019).

Employees of the Port (mean=2,42) grade the impact of the Port on the possibility of *ship accidents* significantly lower than respondents from Ankaran (mean=2,96) and Koper (mean=3,03), (Friedman $\chi^2=7,036$, df=2, Asym.sig.=0,003).

Respondents from Hrvatini (mean=2,36) grade the impact of the Port on the possibility of *rail accidents* significantly lower than respondents from Bertoki (mean=3,13) and Zg. Škofije (mean=3,29), (Friedman $\chi^2=6,594$, df=2, Asym.sig.=0,037).

We can see that employees of the Port and respondents from Hrvatini grade the risk from accidents, which may occur during operation, lower than the average on all elements. It is interesting, that respondents from Hrvatini grade the risk of possible accidents this low. (One of the reasons may be that their village is on the hill, away from railway tracks or a main road.)

Kruskal Wallis Test for determination of extraneous variable: gender on the opinion of respondents from general population.

Table A 4/ 38

Kruskal Wallis Test for determination of extraneous variable: gender on the opinion of

Test Statistics^{a,b}

	Air pollution	Water pollution	Soil pollution	Waste production	Noise generation	Indigenous spec. introd.	Storage of haz. mat.	Road accidents	Ship accidents	Rail accidents
Chi-Square	7,337	10,707	8,768	5,601	,794	5,111	4,412	,251	,853	,173
df	1	1	1	1	1	1	1	1	1	1
Asymp. Sig.	,007	,001	,003	,018	,373	,024	,036	,617	,356	,677

a. Kruskal Wallis Test

b. Grouping Variable: Gender

Kruskal Wallis Test for determination of extraneous variable: employment on the opinion of respondents from general population about the magnitude of marine pollution.

Kruskal Wallis Test for determination of extraneous variable: gender on the opinion of respondents from group of employees about storage of hazardous materials and road accidents.

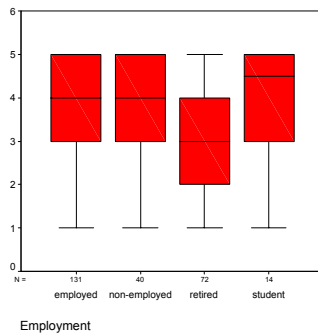

Graph A4/ 56: Magnitude of Port of Koper environmental impact (marine pollution) - influence of ex. variable: employment

2.nd survey

Results of 2.nd survey are similar to the first survey, although respondents grade some of Ports' environmental impact higher than before. Significant differences occur in opinion about the impact the port has on air pollution (mean1=3,31; mean2=3,50, Wilcoxon S.R. Test $z=-2,939$, Asymp.Sig.(2-tailed)=0,003), marine pollution (mean1=3,54; mean2=3,81, Wilcoxon S.R. Test $z=-3,006$, Asymp.Sig.(2-tailed)=0,003), soil pollution (mean1=2,77; mean2=3,06, Wilcoxon S.R. Test $z=-3,877$, Asymp.Sig.(2-tailed)=0,000), noise generation (mean1=3,14; mean2=3,29, Wilcoxon S.R. Test $z=-2,547$, Asymp.Sig.(2-tailed)=0,011), shipping accidents (mean1=2,94; mean2=3,80, Wilcoxon S.R. Test $z=-2,754$, Asymp.Sig.(2-tailed)=0,006) and rail accidents (mean1=2,95; mean2=3,21, Wilcoxon S.R. Test $z=-2,312$, Asymp.Sig.(2-tailed)=0,021).

A correlation occurs between gender and respondents opinion in the 2.nd survey on air pollution (mean-m=3,32, mean-f =3,72, Spearman's $\rho=0,167$, Sig.(2-tailed)=0,000), marine pollution (mean-m=3,57, mean-f =4,10, Spearman's $\rho=0,239$, Sig.(2-tailed)=0,000), waste production (mean-m=2,86, mean-f =3,30, Spearman's $\rho=0,247$, Sig.(2-tailed)=0,000) and alien species introduction (mean-m=2,60, mean-f =2,93, Spearman's $\rho=0,120$, Sig.(2-tailed)=0,021).

A correlation is also evident in the analysis between response and employment, where unemployed and retired respondents rank air pollution, risk from shipping, road and rail accidents higher than employed respondents (Spearman's $\rho=0,120$ (0,211, 0,124, 0,155), Sig.(2-tailed)=0,020 (0,00, 0,017, 0,003))

A correlation occurs between age and opinion on marine pollution and risk from road accidents. Younger respondents grade the risk from road accidents lower than older respondents (Spearman's $\rho=0,119$, Sig.(2-tailed)=0,022). The situation is opposite in the opinion regarding marine pollution, where younger respondents grade it higher (Spearman's $\rho=-0,109$, Sig.(2-tailed)=0,034).

Port of Koper environmental impact – general population / ex. variable: gender

Table A 4/ 39

Port of Koper environmental impact – general population / ex. variable: gender

	Test Statistics ^{a,b}									
	Air pollution	Water pollution	Soil pollution	Waste production	Noise generation	Nonindigenous spec. introd.	Storage of haz. mat.	Road accidents	Ship accidents	Rail accidents
Chi-Square	5,002	11,133	7,246	12,799	,100	1,656	1,121	,461	1,132	,377
df	1	1	1	1	1	1	1	1	1	1
Asymp. Sig.	,025	,001	,007	,000	,752	,198	,290	,497	,287	,539

a. Kruskal Wallis Test

b. Grouping Variable: Gender

Magnitude of the Port of Koper's environmental impacts: air pollution– general population / ex. variable: location of residency

Table A 4/ 40

Magnitude of Port of Koper environmental impact: air pollution– general population / ex. variable: location of residency

Ranks		Test Statistics ^a	
	Mean Rank		
Ankaran	4,11	N	23
Bertoki	4,41	Chi-Square	16,473
Hrvatini	3,39	df	5
Koper	3,41	Asymp. Sig.	,006
Sp Skofije	2,76	a. Friedman Test	
Zg Skofije	2,91		

Testing according to location shows, that there are significant differences in opinion among respondents from different locations of residency and employees of the Port.

Air pollution is graded the highest by respondents from Bertoki (mean=4,25) and Ankaran (mean=4,0). Their opinion is significantly different from respondents from other locations.. Employees of the Port of Koper grade air pollution the lowest. (Wilcoxon Signed Rank Test Z=-4,55, Asymp. Sig. (2-tailed)=0,00).

Between the locations sampled respondents from Bertoki, followed by respondents from Ankaran, Sp. Skofije and Zg. Skofije, grade marine pollution highest.

Results aggregation

Influence of extraneous variables – gender, age and location of residency is identified in this issue, so some of the differences could be contributed to different groups structure.

There is significant difference in opinion of employees of the port compared to respondents from the general population on all issues. Employees grade the environmental impact of the port significantly lower on every question in both surveys. Respondents from the general population grade the Port's environmental impact significantly lower in the 2nd survey than in the 1st survey on most issues. Also Employees grade the influence of the Port it higher on most issue than in the first survey albeit the difference is not statistically significant. The average ranking of the Ports' environmental impact rose in the group of employees and dropped in the group of respondents from the general population.

Port of Koper environmental impact (Q-12)				
Y_6	$X_{i(i=3-7)}$	X_1 / X_2	ΔA	
Storage of hazardous materials	- gender	PK / GP less/more	1st / 2nd down	$i Y_1$ - opinion on the subject
Marine pollution	- gender, age - employment	PK / GP less/more	1st / 2nd down	$X_{i(i=3-7)}$ - control variables (education, employment, gender, location)
Waste generation	- gender	PK / GP less/more	1st / 2nd down	X_1/X_2 - general population/ employees
Road accidents		PK / GP less/more	1st / 2nd down	
Air pollution	- gender - location	PK / GP less/more	1st / 2nd down	PK / GP high/low - employees grade the option significantly different than general population
Noise generation		PK / GP less/more	1st / 2nd similar result	$\text{1st s. / 2nd s down}$ - results of the 2 nd survey are significantly lower than in the 1 st survey
Rail accidents		PK / GP less/more	1st / 2nd similar result	1st s. / 2nd s up - results of the 2 nd survey are significantly higher than in the 1 st survey
Ship accidents		PK / GP less/more	1st / 2nd similar result	
Alien spec. introduction	- gender	PK / GP less/more	1st / 2nd down	
Soil pollution	- gender	PK / GP less/more	1st / 2nd similar result	

Graph A4/ 57: Significant differences – opinion on the Port's environmental impact;

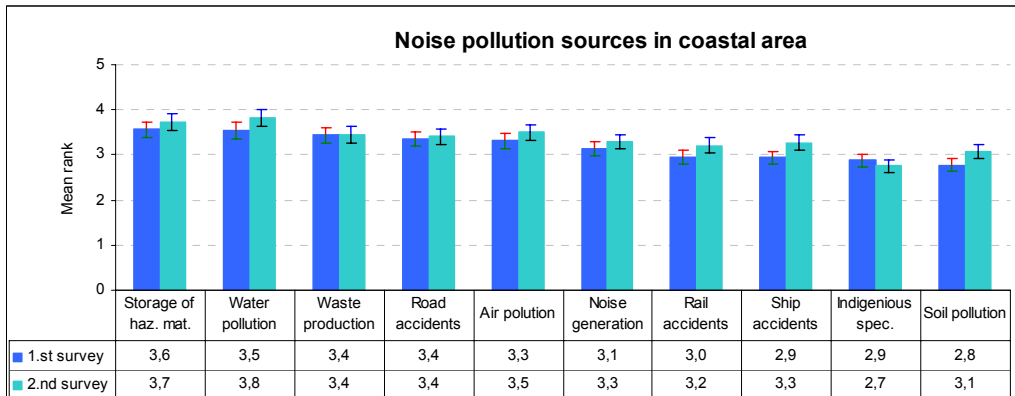

Graph A4/ 58: General differences between the two surveys

Table A 4/ 41
General differences between the two surveys

Test Statistics^b

	Air pollution 2 - Air pollution 1	Water pollution 2 - Water pollution 1	Soil pollution 2 - Soil pollution 1	Waste production 2 - Waste production 1	Noise generation 2 - Noise generation 1	Nonindigenous spec. introd. 2 - Nonindigenous spec. introd. 1	Storage of haz. mat. 2 - Storage of haz. mat. 1	Road accidents 2 - Road accidents 1	Ship accidents 2 - Ship accidents 1	Rail accidents 2 - Rail accidents 1
Z	-2,302 ^a	-3,651 ^a	-1,635 ^a	-3,200 ^a	-,800 ^a	-2,590 ^a	-2,618 ^a	-2,268 ^a	-1,460 ^a	-1,461 ^a
Asymp. Sig. (2-tailed)	,021	,000	,102	,001	,424	,010	,009	,023	,144	,144

a. Based on positive ranks.

b. Wilcoxon Signed Ranks Test

Comparison of both surveys and both groups

Table A 4/ 42
Comparison of the 1st and 2nd survey results - locations of residency end employees respondents groups

Test Statistics^b

	PK Air pollution 1 - Air pollution 1	PK Water pollution 1 - Water pollution 1	PK Soil pollution 1 - Soil pollution 1	PK Waste production 1 - Waste production 1	PK Noise 1 - Noise generation 1	PK Indigenous spec. introd. 1 - Nonindigenous spec. introd. 1	PK Storage of haz. mat. 1 - Storage of haz. mat. 1	PK Road accidents 1 - Road accidents 1	PK Ship accident 1 - Ship accidents 1	PK Rail accidents 1 - Rail accidents 1
Z	-3,986 ^a	-3,615 ^a	-3,377 ^a	-3,419 ^a	-3,842 ^a	-3,458 ^a	-3,627 ^a	-2,938 ^a	-2,914 ^a	-1,654 ^a
Asymp. Sig. (2-tailed)	,000	,000	,001	,001	,000	,001	,000	,003	,004	,098

a. Based on positive ranks.

b. Wilcoxon Signed Ranks Test

Test Statistics^b

	PK Air pollution 2 - Air pollution 2	PK Water pollution 2 - Water pollution 2	PK Soil pollution 2 - Soil pollution 2	PK Waste production 2 - Waste production 2	PK Noise generation 2 - Noise generation 2	PK Nonindigenous spec. introd. 2 - Nonindigenous spec. introd. 2	PK Storage of haz. mat. 2 - Storage of haz. mat. 2	PK Road accidents 2 - Road accidents 2	PK Ship accidents 2 - Ship accidents 2	PK Rail accidents 2 - Rail accidents 2
Z	-4,550 ^a	-4,171 ^a	-2,531 ^a	-3,693 ^a	-3,807 ^a	-4,063 ^a	-3,302 ^a	-2,549 ^a	-2,779 ^a	-2,769 ^a
Asymp. Sig. (2-tailed)	,000	,000	,011	,000	,000	,000	,001	,011	,005	,006

a. Based on positive ranks.

b. Wilcoxon Signed Ranks Test

Respondents from the group general population - comparison of 1st and 2nd survey results

Table A 4/ 43

Port of Koper environmental impact: comparison of the 1st and 2nd survey results for general population

Test Statistics^b

	Air pollution 2 - Air pollution 1	Water pollution 2 - Water pollution 1	Soil pollution 2 - Soil pollution 1	Waste production 2 - Waste production 1	Nonindigenous spec. introd. 2 - Nonindigenous spec. introd. 1	Storage of haz. mat. 2 - Storage of haz. mat. 1	Road accidents 2 - Road accidents 1
Z	-2,302 ^a	-3,651 ^a	-1,635 ^a	-3,200 ^a	-2,590 ^a	-2,618 ^a	-2,268 ^a
Asymp. Sig. (2-tailed)	,021	,000	,102	,001	,010	,009	,023

a. Based on positive ranks.

b. Wilcoxon Signed Ranks Test

Respondent from the group of employees - comparison of the 1st and 2nd survey results

Table A 4/ 44

Comparison of the 1st and 2nd survey results for group of employees

Test Statistics^c

	PK2 Air pollution - PK1 Air pollution	PK2 Water pollution - PK1 Water pollution	PK 2 Soil pollution - PK1 Soil pollution	PK2 Waste production - PK1 Waste production	PK2 Noise generation - PK1 Noise
Z	-,019 ^a	-,377 ^a	-,782 ^a	-,336 ^b	-1,280 ^a
Asymp. Sig. (2-tailed)	,985	,706	,434	,737	,201

a. Based on negative ranks.

b. Based on positive ranks.

c. Wilcoxon Signed Ranks Test

Test Statistics^d

	PK2 Nonindigenous spec. introd. - PK1 Indigenous spe.introd.	PK2 Storage of haz. mat. - PK1 Storage of haz. mat.	PK2 Road accidents - PK1 Road accidents	PK2 Ship accidents - PK1 Ship accident	PK2 Rail accidents - PK1 Rail accidents
Z	-,237 ^a	-,196 ^b	-,730 ^b	-1,728 ^b	,000 ^c
Asymp. Sig. (2-tailed)	,813	,845	,465	,084	1,000

a. Based on positive ranks.

b. Based on negative ranks.

c. The sum of negative ranks equals the sum of positive ranks.

d. Wilcoxon Signed Ranks Test

Port of Koper environmental impacts ranking according to the severity and probability of the present level of pollution, hazardous potential (worst case scenario, accidents), presence of continuous impacts, bioaccumulation hazard, toxicity hazard, potential harmful impact on human health and potential harmful impact on ecosystem.

Table A 4/ 45
Ranking of Ports' environmental impacts

	Present level of pollution		Hazardous potential (worst case scenario, accidents)		Presence of continuous impacts		Bioaccumulation hazard		Toxicity hazard		Potential harmful impact on human health		Potential harmful impact on ecosystem		Ranking (*)
	S	P	S	P	S	P	S	P	S	P	S	P	S	P	
Air poll.	2	3	3	2	1	1	2	3	3	2	2	2	2	2	3,4
Marine pol	2	3	2	3	2	3	3	3	3	4	2	3	4	3	4,1
Soil poll.	1	1	1	1	1	1	1	1	1	1	1	1	1	1	2,3
Waste generation	2	2	2	2	2	2	2	2	2	2	2	2	3	2	3,3
Noise generation	3	4	1	1	4	4	1	1	1	1	2	3	1	1	3,3
Alien spe. introd.	3	4	4	4	2	4	4	4	3	3	3	2	4	3	4,6
Storage of haz. mat. accidents	2	3	4	3	1	3	3	3	4	3	3	3	3	3	4,2
Road accidents	1	4	4	4	2	4	2	2	4	4	3	4	3	4	4,5
Ship accidents	1	4	4	4	2	3	4	3	4	4	3	4	4	4	4,7
Rail accidents	1	3	4	3	2	3	2	2	4	3	3	2	3	2	3,9

(*)- calculation: $\Sigma(\text{ranks}/\text{number of marks}) \cdot 5/4$

Severity (S)	Probability for damage to human health or ecosystems (P)
Catastrophic impact	4 High (happens often)
Medium impact	3 Medium (can happen)
Small impact	2 Low (can happen in similar industries)
No impact	1 Very low (not likely to happen)

**A 4/7 VARIABLE Y7: MORAL RESPONSIBILITY TO ENVIRONMENT AND TRUST
TECHNOLOGICAL SOLUTIONS OF ENVIRONMENTAL PROBLEMS**

The following question shows the moral responsibility to environmental issues and the extent of trust in technological development and technological solution of environmental problems.

Respondents were asked in question Q-13 to rank on the scale of 1-4: (1=don't agree at all; 4=strongly agree) their level of their agreement with the following statements

- a.) We believe too much in science and technology and too little in intuition and feelings.*
- b.) Modern science is causing more harm than good.*
- c.) Any change in the environment, caused by human activity, no matter how scientifically founded, is harmful.*
- d.) Modern science will solve all environmental problems without us having to change our life habits.*
- e.) We worry too much about our future and environment and not enough about price rates and employment at present.*
- f.) Nearly everything we do is harmful to the environment.*
- g.) Respondents worry too much that the development of modern technological society will harm the environment.*

Results of 2001 and 2003 survey - Means – Agreement with statements:

Table A 4/ 46
Extent of trust in technological development and technological solution of environmental problems

	N₁	Mean₁	Std. Deviation₁	N₂	Mean₂	Std. Deviation₂
(a) Too much science	255	2,6	0,8	360	2,7	0,8
(b) Harmful science	257	2,5	0,9	364	2,3	0,8
(c) Harmful human impact	256	2,4	0,9	364	2,6	0,9
(d) Technological fix	257	2,1	0,8	357	2,0	0,8
(e) Too much concern for the environment	260	2,3	0,9	371	2,2	0,9
(f) Everything we do is harmful	262	2,6	0,8	370	2,6	0,8
(g) Too much concern	257	2,5	0,9	369	2,4	0,8

- a.) We believe too much in science and technology and too little in intuition and feelings.
- b.) Modern science is causing more harm than good.
- c.) Any change in the environment, caused by human activity, no matter how scientifically founded, is harmful.
- d.) Modern science will solve all environmental problems without us having to change our life habits.
- e.) We worry too much about our future, the environment, and not enough about price rates and employment at present.
- f.) Nearly everything we do is harmful to the environment.
- g.) Respondents worry too much that the development of modern technological society will harm the environment.

Table A 4/ 47
Results of 2001 and 2003 survey – mean agreement with statements / gender

	a-Too much science		b-Harmful science		c-Harmful human impact		d-Technological fix	
	2001	2003	2001	2003	2001	2003	2001	2003
male	2,6	2,5	2,4	2,3	2,5	2,5	2,1	2,0
female	2,6	2,5	2,6	2,4	2,4	2,7	2,1	2,0

	e-Too much concern for the environment		f-Everything we do is harmful		g-Too much concern about impact of tech.	
	2001	2003	2001	2003	2001	2003
male	2,3	2,2	2,6	2,5	2,5	2,4
female	2,2	2,1	2,5	2,7	2,5	2,4

Table A 4/ 48

Results of 2001 and 2003 survey – mean agreement with statements / education

	a-Too much science		b-Harmful science		c-Harmful human impact		d-Technological fix	
	2001	2003	2001	2003	2001	2003	2001	2003
high	2,4	2,6	2,3	2,2	2,4	2,5	2,1	1,8
medium	2,8	2,7	2,6	2,4	2,5	2,6	2,2	2,0
primary	2,3	2,7	2,4	2,5	2,4	2,6	2,3	2,3
none	2,8	3,1	3,0	2,7	2,2	3,1	2,1	1,9
student	2,8	2,3	2,6	2,1	2,6	2,8	1,8	2,9

	e-Too much concern for the environment		f-Everything we do is harmful		g-Too much concern about impact of tech.	
	2001	2003	2001	2003	2001	2003
high	2,1	2,0	2,4	2,5	2,2	2,2
medium	2,3	2,3	2,6	2,6	2,6	2,6
primary	2,4	2,5	2,6	2,8	2,6	2,6
None	2,0	2,4	2,8	2,8	2,9	2,2
student	2,3	2,9	2,6	2,4	2,4	2,9

Table A 4/ 49

Results of 2001 and 2003 survey – mean agreement with statements / employment

	a-Too much science		b-Harmful science		c-Harmful human impact		d-Technological fix	
	2001	2003	2001	2003	2001	2003	2001	2003
employed	2,6	2,6	2,4	2,3	2,4	2,5	2,1	1,9
unemployed	2,8	2,7	2,8	2,4	2,5	2,7	2,4	2,0
retired	2,7	2,8	2,6	2,5	2,5	2,7	2,3	2,1
student	2,3	2,7	2,2	2,3	1,8	2,6	1,6	2,0

	e-Too much concern for the environment		f-Everything we do is harmful		g-Too much concern about impact of tech.	
	2001	2003	2001	2003	2001	2003
employed	2,2	2,1	2,5	2,6	2,5	2,4
unemployed	2,4	2,1	2,7	2,8	2,7	2,2
retired	2,3	2,4	2,5	2,5	2,4	2,5
student	2,0	2,2	2,7	2,6	2,3	2,4

Table A 4/ 50

Results of 2001 and 2003 survey – mean agreement with statements / employment

	a-Too much science		b-Harmful science		c-Harmful human impact		d-Technological fix	
	2001	2003	2001	2003	2001	2003	2001	2003
18-25	2,6	2,6	2,5	2,2	2,4	2,6	2,3	1,9
26-35	2,5	2,5	2,3	2,1	2,5	2,4	2,0	1,8
36-45	2,7	2,9	2,6	2,4	2,4	2,6	2,0	2,0
46-55	2,7	2,7	2,5	2,4	2,5	2,7	2,1	1,9
56-65	2,6	2,7	2,7	2,4	2,7	2,5	2,2	2,0
66-75	2,7	2,7	2,5	2,4	2,4	2,9	2,4	2,1
76-	2,5	2,6	2,3	2,5	2,2	2,6	2,4	2,3

Table A 4/ 51
Results of 2001 and 2003 survey – mean agreement with statements / age

	e-Too much concern for the environment		f-Everything we do is harmful		g-Too much concern about impact of tech.	
	2001	2003	2001	2003	2001	2003
18-25	2,4	2,3	2,8	2,6	2,6	2,4
26-35	2,0	2,1	2,7	2,5	2,3	2,2
36-45	2,3	2,1	2,5	2,8	2,6	2,4
46-55	2,2	2,2	2,4	2,7	2,6	2,4
56-65	2,4	2,3	2,6	2,4	2,6	2,5
66-75	2,5	2,2	2,4	2,6	2,5	2,4
76-	2,2	2,1	2,4	2,5	2,4	2,5

Results show, that respondents find the statement (a) 'We believe too much in science and technology and too little in intuition and feelings' most agreeable (mean=2,62). There is significant difference in opinion among respondents with different level of education, where students in middle school show the highest agreement with the statement (mean=3,14). Those that agree least with the statement are respondents with primary education (mean=2,35). (Kruskal Wallis Test $\chi^2=14,168$, Asymp.Sig. = 0,015).

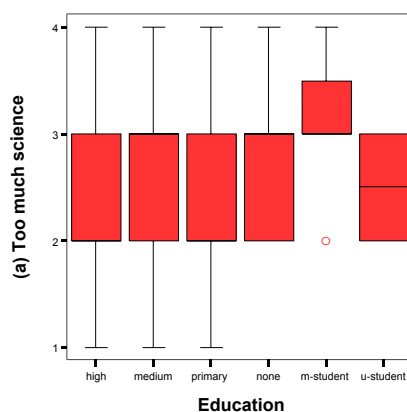

Graph A4/ 59: 'We believe too much in science and technology and too little in intuition and feelings' - ex. Variable: education

Statement (b) 'Modern science is causing more harm than good' was also received a high grade (mean=2,57) and a correlation is observed in the analysis according to gender, where female respondent grade the statement with the mean=2,63 and male respondents with the mean=2,36. (Spearman's $\rho=0,146$, sig. (2-tailed)=0,019).

Respondents from Ankaran (mean=2,24) and respondents from the Port of Koper (mean =2,11) grade this statement lower than others, whereas respondents from City of Koper grade this statement higher than the average although the differences are not statistically significant.

Statement (c.) 'Any change in environment, caused by human activity, no matter how scientifically founded, is harmful' has a mean=2,44. Respondents in the City of Koper show a lower level of agreement (mean=2,20) than other respondents (mean=2,43 – 2,65), but these differences are not statistically significant.

Statement (d.) 'Modern science will solve all environmental problems without us having to change our life habits' received a mean=2,14. There is a significant difference in the opinions expressed among respondents with different employment status. Students gave it the lowest ranking (mean=1,60). The highest grade was given by non-employed respondents (mean=2,43). (Kruskal Wallis Test $\chi^2 = 12,281$, Asymp. Sig. = 0,006)

Respondents from different locations also grade this statement differently. Respondents from Sp. Škofije (mean=1,50) grade the statement significantly lower than respondents from other

locations. Respondents from City of Koper (mean 2,42) graded the statement higher than other respondents, but these differences are not significant.

Statement (e) *'We worry too much about our future and environment and not enough about inflation and employment at present'* was also given a relatively high rank (mean=2,51). Respondents from Bertoki grade the statement much lower than others (mean = 1,79), whereas respondents from the City of Koper grade the statement much higher than others do (mean = 2,64). The differences are not statistically significant.

The deep ecology statement (f) *'Everything we do is harmful to the environment'* was graded as the second most believable statement (mean=2,57). In analysis of this question, a significant correlation occurs between age and this statement, showing that younger respondents (age 18-25) grade harm of human activities higher than older respondents do. (Spearman's $\rho=-0,146$, sig (2-tailed)=0,018).

Statement (g.) *'We worry too much that the development of modern technological society will harm the environment'* was graded with the mean=2,51.

There is a significant difference in opinion among respondents with different levels of education. Respondents with no education grade the statement with a mean=2,86, whereas respondents with a high education and students at university grade the statement significantly lower (mean=2,20) (Kruskal Wallis Test $\chi^2 = 12,836$, Asymp. Sig. = 0,025).

2.nd survey

There is correlation in opinion on question f) *'Nearly everything we do is harmful to the environment'* to gender (Spearman's $\rho=0,13$, Sig (2-tailed)=0,012, N=370), where female respondents grade the statement (mean=2,71) significantly higher than male respondents (mean=2,51) (Kruskal Wallis $\chi^2=6,22$, Asymp. Sig.=0,013).

There is also correlation between education/employment with the answers to questions b.), c.), d.) and e.). Statement b) *'modern science is causing more harm than good'* is given the lowest ranking by students (mean=2,0 – 2,13) and by respondents with high education (mean=2,17). Respondents with medium education (mean=2,42), primary education (mean=2,53) and no education (mean=2,70) grade the statement significantly higher. (Kruskal Wallis $\chi^2=12,89$, df=5, Asymp. Sig.=0,024).

There is also a significant difference in the analysis according to employment, where employed respondents (mean=2,25), grade the statement lower than unemployed (mean=2,41) or retired respondents (mean=2,49). (Kruskal Wallis $\chi^2=6,06$, df=2, Asymp. Sig.=0,048).

Another correlation is present between age and agreement of respondents with this statement, where younger respondents (mean=2,23) grade the statement lower than older respondents (mean=2,53). (Spearman's $\rho=0,128$, Sig. (2-tailed)=0,015).

There is also a difference in the opinions of respondents from different locations (Friedman $\chi^2=18,311$, Asymp.Sig.=0,005). Respondents from the Port grade give it the lowest grade (mean=2,2), while respondents from Hrvatini give it the highest grade (mean=2,7).

Statement c.) *'Any change in the environment, caused by human activity, no matter how scientifically founded, is harmful'* is given the highest rank by respondents with no education (mean=3,13) and students in middle school (mean=3,0). Respondents with primary school (mean=2,63), medium school (mean=2,62) and university students (mean=2,65), grade the statement lower and respondents with a high education grade it the lowest of all the educational groups (mean=2,47). The correlation among education and opinion is statistically significant (Spearman's $\rho=0,108$, Sig.(2-tailed)=0,039).

There is a significant difference in opinion expressed about question regarding employment, where employed respondents (mean=2,49), grade the statement lower than non-employed

(mean=2,75) or retired respondents (mean=2,69). (Kruskal Wallis $\chi^2=6,937$, $df=2$, Asymp. Sig.=0,031).

Agreement with the statement d.) *'Modern science will solve all environmental problems without us having to change our life habits'* was graded the lowest (mean=1,98). There is a correlation between education and opinion regarding this statement (Spearman's $\rho=0,136$, $df=5$, Sig.(2-tailed)=0,01); respondents with a high education (mean=1,80) and students at the university (mean=1,77) give the statement the lowest grade. Respondents with medium education (mean=2,26), primary education (mean=2,32) and no education (mean=2,40) graded the statement significantly higher. (Kruskal Wallis $\chi^2=17,54$, $df=5$, Asymp. Sig.=0,004).

There also exists a correlation between opinion on this statement and employment (Spearman's $\rho=0,106$, $df=2$, Sig.(2-tailed)=0,018). Employed respondents (mean=1,91) grade the statement lower than non-employed (mean=2,00) or retired respondents (mean=2,11). And a correlation between agreement of respondents with this statement and age, where younger respondents (mean=1,91) grade the statement lower than older respondents do (mean=2,528). (Spearman's $\rho=0,107$, Sig.(2-tailed)=0,043).

There is also difference in the opinions expressed from different locations (Friedman $\chi^2=25,35$, Asymp. Sig.=0,00). Respondents from Port of Koper and Bertoki (mean=1,8) grade it the lowest, while respondents from Hrvatini give it the highest grade (mean=2,7).

Statement e.) *'We worry too much about our future and environment and not enough about inflation and employment at present'* was graded differently by respondents with different education (Spearman's $\rho=0,143$, Sig. (2-tailed)=0,006). Students (mean=1,83) and respondents with a high education (mean=1,96) express the lowest agreement to the statement. Respondents with medium (mean=2,26) and no education (mean=2,40) grade it a bit higher while the higher agreement to this statement is expressed by respondents with primary education (mean=2,51). The difference is statistically significant (Kruskal Wallis $\chi^2=21,32$, $df=5$, Asymp. Sig.=0,001).

There is a correlation between employment status and opinion on this question (Spearman's $\rho=0,122$, Sig. (2-tailed)=0,019). Employed respondents (mean=2,09) grade the statement lower than unemployed (mean=2,12) or retired respondents (mean=2,35). The difference is significant (Kruskal Wallis $\chi^2=7,096$, $df=2$, Asymp. Sig.=0,029).

A difference in opinion occurs between respondents from different locations (Friedman $\chi^2=19,618$, Asymp. Sig.=0,003). Respondents from Spodnje and Zgornje Škofije (mean=2,0) grade this statement the lowest, whereas respondents from Hrvatini give it the highest grade (mean=2,7).

Results aggregation

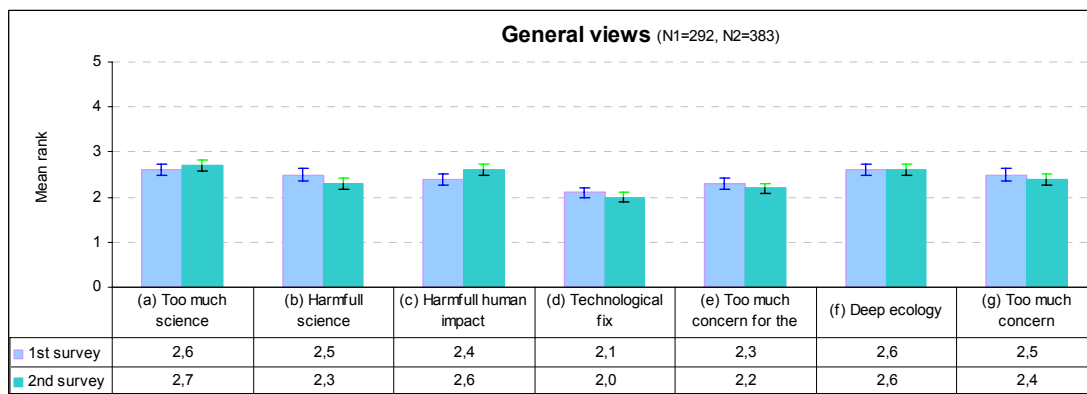

Graph A4/ 60: General results of both surveys: trust in technological development and technological solutions of environmental problems

The extent of trust in technological development and technological solutions of environmental problems was addressed in seven statements.

The extent of trust in technological solutions (Q-13)

iY_i	$X_{i(i=3-7)}$	X_1 / X_2	ΔA
A.) Too much science and tech.	- Education	PK / GP similar	1st / 2nd similar result
F.) Everything we do is harmful	- Gender	PK / GP similar result	1st / 2nd similar result
G.) Too much worry about development	- Education	PK / GP similar result	1st / 2nd similar result
B.) Harmfull science	- Gender - Education - Location	PK / GP less/more	1st / 2nd down
C.) Harmfull every human impact	- Education - Employment	PK / GP similar result	1st / 2nd up
E.) Too much env. concern vs. employ. and prices	- Education - Employment	PK / GP less / more	1st / 2nd similar
D.) Technological fix	- Employment - Education, age - Location	PK / GP similar result	1st / 2nd similar

- iY_i - opinion on the subject
- $X_{i(i=3-7)}$ - control variables (education, employment, gender, location)
- X_1/X_2 - general population/ employees

- PK / GP high/low - employees grade the option significantly different than general population
- 1st s. / 2nd s down - results of the 2nd survey are significantly lower than in the 1st survey
- 1st s. / 2nd s up - results of the 2nd survey are significantly higher than in the 1st survey

Graph A4/ 61: Significant differences – trust in technological development and technological solutions of environmental problems

The influence of education, employment status, gender and age was identified. We can see that the general views do not differ significantly between either employees or respondents from the general population.

Respondents display a significantly higher trust in science and technology in the second survey. Respondents graded question *b) Modern science is causing more harm than good* lower (mean=2,34) than in first survey (mean=2,49) (Wilcoxon Signed Ranks Test $z = -2,1$, Asymp. Sig. (2-tailed)=0,036). Respondents also ranked statement *d) 'Modern science will solve all environmental problems without us having to change our life habits'* significantly higher (mean=2,59) than in first survey (mean=2,14) (Wilcoxon Signed Ranks Test $z = -2,217$, Asymp. Sig. (2-tailed)=0,0276).

Other statements are ranked similarly in both surveys.

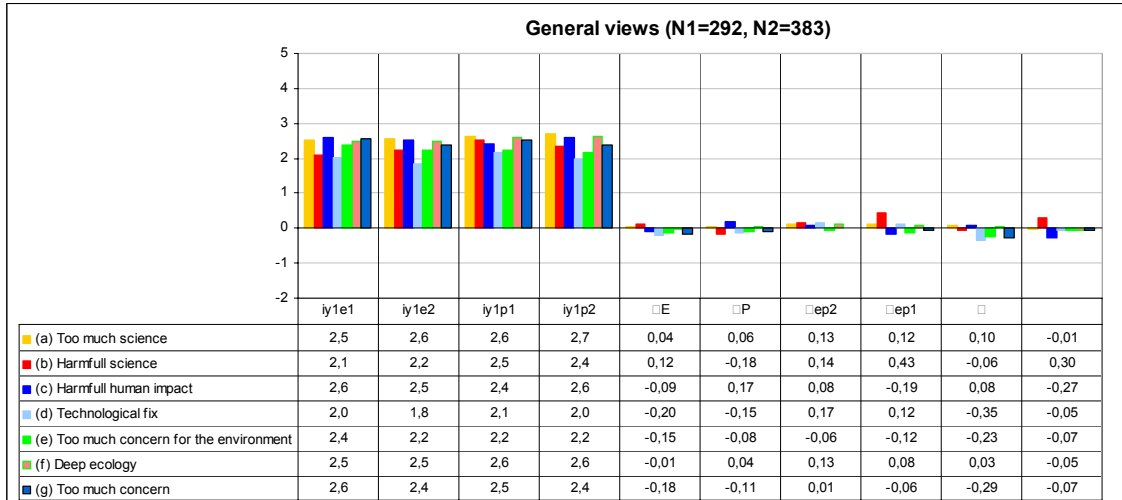

- $y_{(5-8)e}^1$ - result (sample mean) for employees (e) in the 1st survey (Graph: y5-8e1)
- $y_{(5-8)e}^2$ - result (sample mean) for employees (e) in the 2nd survey (Graph: y5-8e2)
- $y_{(5-8)p}^1$ - result (sample mean) for general population (p) in the 1st survey (Graph: y5-8p1)
- $y_{(5-8)p}^2$ - result (sample mean) for general population (p) in the 2nd survey (Graph: y5-8p2)
- 5-8 - index, marking partial results for variable Y5, represented by result from the question Q-8
- $\Delta E_{(5-8)}$ - difference between 1st and 2nd survey - employees (Graph: dE5-8)
- $\Delta P_{(5-8)}$ - difference between 1st and 2nd survey - general population (Graph: dP5-8)
- $\Delta ep_{(5-8)}^1$ - difference in 1st survey – employees/general population (Graph: d5-8ep1)
- $\Delta ep_{(5-8)}^2$ - difference in 2nd survey - employees/general population (Graph: d5-8ep2)
- $\Delta A_{(5-8)}$ - common difference for both groups in both surveys (Graph: dA5-8)

Graph A4/ 62: Results quantification

A 4/8 VARIABLE Y8: PARTICIPATION IN ENVIRONMENTAL PROTECTION

Respondents were asked in question to grade their readiness to participate in environmental protection on the rank 1-4. Questions were as follows:

- a) Would you be ready to pay higher prices for goods in order to protect the environment?
- b) Would you be ready to pay higher taxes in order to protect the environment?
- c) Would you be ready to lower your standard of living in order to protect the environment (simple food, less tourism, smaller use of luxurious items)?
- d) Are you collecting your waste separately ?
- e.) If you are not collecting them separately yet - would you collect your waste separately ?
- f.) Are you recycling everything that is possible to recycle?
- g.) Are you ready to use your car less in order to protect the environment if the public transport would be available?
- h.) Are you ready to lower your energy consumption?
- i.) Would you be ready to pay higher prices for some products, because the Port of Koper wishes to implement better environmental protection program?

Table A 4/ 52
Readiness to participate in environmental protection – 1st and 2nd survey results

	N_1	$Mean_1$	$Std. Deviation_1$	N_2	$Mean_2$	$Std. Deviation_2$
a.) Higher prices	242	2,6	1,1	349	2,8	1,1
b.) Higher taxes	255	2,6	1,2	360	2,8	1,1
c.) Lower standard	255	2,7	1,1	363	2,8	1,1
d.) Separate waste collection-existing	263	2,7	1,2	377	3,1	1,1
e.) Separate waste collection-readiness	260	3,7	0,7	375	3,8	0,5
f.) Recycling	255	2,5	1,2	368	2,6	1,1
g.) Less car use	256	3,3	0,9	369	3,3	1,0
h.) Lower energy consumption	256	3,3	0,9	374	3,4	0,9

1st survey - Respondents show the greatest readiness to separate waste for collection. Separate waste collection is starting in many parts of Slovenia and a lot of education, information and presentations have been performed by the governmental organizations in this area. (mean=3,70). Separate collection obviously is not well organized yet, since people grade the capability of present waste collection with a mean=2,65.

The next most important action is to lower car use (mean=3,32) and energy consumption (mean=3,30).

People grade their willingness to lower their standard of living with a mean=2,73. Respondents readiness to pay higher prices is graded by a mean=2,64 and their willingness to pay higher taxes to protect the environment is even lower (mean=2,59). The lowest grade is given by respondents to the idea of paying higher prices for goods because Port of Koper would raise their prices in order to implement a better environmental protection program (mean = 2,06).

2nd survey - There are significant differences in opinion between first and second survey on three questions:

- b) Would you be ready to pay higher taxes in order to protect the environment?
- d) Are you collecting your waste separately?
- e.) If you are not collecting them separately yet - would you collect your waste separately ?

Table A 4/ 53
Results of 2001 and 2003 survey – Readiness to participate in environmental protection / gender

	a-Higher prices		b-Higher taxes		c-Lower standard		d-Curr. Separate waste	
	2001	2003	2001	2003	2001	2003	2001	2003
male	2,7	2,9	2,6	2,9	2,7	2,8	2,7	3,2
female	2,6	2,8	2,6	2,8	2,7	2,8	2,6	3,1
	e-Readiness for sep. waste		f- Recycling		g-Less car use		h-Lower energy consumption	
	2001	2003	2001	2003	2001	2003	2001	2003
male	3,7	3,8	2,5	2,6	3,3	3,3	3,2	3,4
female	3,8	3,9	2,6	2,6	3,3	3,2	3,4	3,4

Table A 4/ 54
Results of 2001 and 2003 survey – Readiness to participate in environmental protection / education

	a-Higher prices		b-Higher taxes		c-Lower standard		d-Curr. Separate waste	
	2001	2003	2001	2003	2001	2003	2001	2003
high	2,7	3,0	2,7	3,0	2,7	3,1	2,5	3,2
medium	2,6	2,8	2,5	2,8	2,7	2,6	2,8	3,2
primary	2,7	2,6	2,5	2,7	2,9	2,5	2,6	3,1
none	2,4	2,6	2,7	2,0	2,7	2,7	3,3	3,5
student	3,0	3,5	2,9	3,4	2,4	3,5	2,1	2,3
	e-Readiness for sep. waste		f- Recycling		g-Less car use		h-Lower energy consumption	
	2001	2003	2001	2003	2001	2003	2001	2003
high	3,5	3,9	2,3	2,6	3,2	3,4	3,2	3,5
medium	3,7	3,8	2,6	2,6	3,4	3,2	3,4	3,3
primary	3,9	3,8	2,8	2,7	3,5	3,3	3,3	3,2
none	3,8	3,8	2,8	2,4	2,8	3,0	3,4	3,3
student	3,7	3,9	2,1	2,6	3,3	3,6	3,1	3,5

Table A 4/ 55

Results of 2001 and 2003 survey – Readiness to participate in environmental protection / employment

	a-Higher prices		b-Higher taxes		c-Lower standard		d-Curr. Separate waste	
	2001	2003	2001	2003	2001	2003	2001	2003
employed	2,6	2,9	2,6	3,0	2,8	2,9	2,6	3,1
unemployed	2,7	2,9	2,6	2,7	2,8	2,7	2,6	2,8
retired	2,8	2,7	2,7	2,7	2,8	2,6	2,9	3,4
student	2,8	4,0	2,5	4,0	1,9	4,0	1,8	4,0
	e-Readiness for sep. waste		f- Recycling		g-Less car use		h-Lower energy consumption	
	2001	2003	2001	2003	2001	2003	2001	2003
employed	3,7	3,8	2,4	2,6	3,3	3,3	3,4	3,5
unemployed	3,7	3,8	2,6	2,3	3,4	3,3	3,3	3,2
retired	3,7	3,9	2,9	2,7	3,5	3,1	3,2	3,2
Student	3,4	4,0	1,6	4,0	2,6	4,0	2,7	4,0

Table A 4/ 56

Results of 2001 and 2003 survey – Readiness to participate in environmental protection / age

	a-Higher prices		b-Higher taxes		c-Lower standard		d-Curr. Separate waste	
	2001	2003	2001	2003	2001	2003	2001	2003
18-25	2,5	2,8	2,5	2,8	2,5	2,6	2,3	2,8
26-35	2,4	2,8	2,6	2,8	2,6	2,9	2,4	3,0
36-45	2,8	2,8	2,7	2,9	2,8	2,8	2,8	3,1
46-55	2,7	3,0	2,5	2,9	2,8	3,0	2,5	3,1
56-65	2,5	2,7	2,5	2,9	2,7	2,7	3,0	3,5
66-75	2,8	2,7	2,6	2,6	2,8	2,4	2,9	3,3

	e-Readiness for separate waste collection		f- Recycling		g-Less car use		h-Lower energy consumption	
	2001	2003	2001	2003	2001	2003	2001	2003
18-25	3,6	3,7	2,3	2,2	3,3	3,2	3,1	3,1
26-35	3,9	3,9	2,5	2,6	3,1	3,3	3,2	3,5
36-45	3,8	3,9	2,5	2,7	3,6	3,4	3,5	3,4
46-55	3,6	3,7	2,4	2,7	3,2	3,3	3,3	3,5
56-65	3,6	3,9	3,2	2,6	3,4	3,1	3,5	3,4
66-75	3,7	3,8	2,7	2,4	3,4	3,1	3,2	3,1
76-	3,6	3,8	2,6	2,5	3,3	3,4	2,9	3,3

Table A 4/ 57

Results of 2001 and 2003 survey – Readiness to participate in environmental protection / location

	Ankaran		Bertoki		Hrvatini		Koper		Port of Koper		Sp. Skofije		Zg Skofije	
	2001	2003	2001	2003	2001	2003	2001	2003	2001	2003	2001	2003	2001	2003
a	2,6	3,0	2,6	2,8	3,0	2,9	2,7	2,6	2,2	3,3	2,6	2,8	2,6	2,9
b	2,4	2,9	2,4	2,9	2,9	2,5	2,7	2,8	2,3	3,5	2,9	2,7	2,6	2,7
c	2,7	2,8	2,7	2,8	2,7	2,5	2,9	2,7	2,2	3,5	2,7	2,6	2,9	2,8
d		3,4		2,7		2,7		3,3		4,0		2,4		2,9
e		3,8		3,9		3,8		3,8		4,6		3,8		3,7
f	2,5	2,5	2,5	2,8	2,7	2,6	2,6	2,5	2,5	3,1	2,1	2,4	2,2	2,3
g	3,3	3,1	3,3	3,2	3,5	3,3	3,4	3,4	3,1	4,0	3,3	3,2	3,2	3,0
h	3,1	3,4	3,1	3,4	3,3	3,1	3,5	3,3	3,3	3,8	3,1	3,4	3,4	3,2
i	2,0	2,2	2,0	1,9	2,1	2,2	2,1	2,1	2,2	3,0	2,3	2,0	1,6	2,1

Table A 4/ 58
Impact of employment

Test Statistics ^{a,b}								
	Higher prices	Higher taxes	Lower standard	Separate waste collection	Separate waste collection	Recycling	Less car use	Lower energy consumption
Chi-Square	2,250	9,636	5,750	15,837	10,255	6,620	7,039	13,903
df	3	3	3	3	3	3	3	3
Asymp. Sig.	,522	,022	,124	,001	,017	,085	,071	,003

a. Kruskal Wallis Test
b. Grouping Variable: Employment

Table A 4/ 59
Impact of education

Test Statistics ^{a,b}								
	Higher prices	Higher taxes	Lower standard	Separate waste collection	Separate waste collection	Recycling	Less car use	Lower energy consumption
Chi-Square	7,185	9,601	12,917	9,030	11,704	3,045	,822	11,135
df	5	5	5	5	5	5	5	5
Asymp. Sig.	,207	,087	,024	,108	,039	,693	,976	,049

a. Kruskal Wallis Test
b. Grouping Variable: Education

(a) Would you be prepared to pay higher prices for goods in order to protect the environment?

1st survey - There was no significant difference or correlation among answers from the different groups to the question (a) *Would you be ready to pay higher prices for goods in order to protect the environment?* Respondents readiness to pay higher prices was given a mean rank =2,64 on the scale 1-4 showing that people are unenthusiastic about the idea. In analysis according to location some difference occurred among employees of the Port, people from Hrvatini and other respondents. Although as the diagram shows, the employees of the port grade the question with the lowest grade and respondents from Hrvatini with the highest grade albeit the difference is not statistically significant.

2nd survey - There are no significant differences between the different groups, and in a general comparison of results from the first and second survey, although we can see that people grade the question in the first survey lower (mean=2,6) than in second survey (mean=2,84). A significant difference occurs when we make a comparison between the first and second survey in Ankaran and in the Port of Koper.

Table A 4/ 60
Comparison of 1st and 2nd survey results for question a.)

Test Statistics ^c							
	1-Ankaran - 2-Ankaran	1-Bertoki - 2-Bertoki	1-Hrvatini - 2-Hrvatini	1-Port of Koper - 2-Port of Koper	1-Koper - 2-Koper	1-SpSkofije - 2-Sp Skofije	1-Zg Skofije - 2-Zg Skofije
Z	-2,043 ^a	-,312 ^a	-,787 ^b	-3,239 ^a	-1,565 ^b	-1,561 ^a	-,877 ^a
Asymp. Sig. (2-tailed)	,041	,755	,431	,001	,118	,119	,381

a. Based on positive ranks.
b. Based on negative ranks.
c. Wilcoxon Signed Ranks Test

b) Would you be ready to pay higher taxes in order to protect the environment?,

1st survey - There was no significant difference or correlation among answers from the different groups on the question *b) Would you be ready to pay higher taxes in order to protect the environment?*, also. The pattern and grade was similar that given for question (a). There are some difference in opinions among people from Hrvatini and employees of the Port, but these are not statistically significant.

2nd survey - There are significant differences in the second survey in the analysis of opinion of respondents of different employment status (Wilcoxon Signed Ranks Test (Z)=9,636, Asymp. Sig. (2-tailed) =0,022). Employed people (mean=3,0) and students (mean=3,9) express higher readiness to pay higher taxes for environmental protection than unemployed (mean=2,7) and retired people (mean=2,7).

There is also a correlation between education and opinions given on taxation (Spearman's $\rho = -0,120$, Sig.(2-tailed)=0,023), where students (mean=3,0) and people with a high education (mean=3,0) grade their willingness to comply with statement higher than people with medium (mean=2,8), primary (mean=2,7) or no education (mean=2).

There is a difference between the results of both surveys in that we see, that respondents in the 2nd survey (mean=2,84) grade their readiness to pay environmental taxes higher than in the 1st survey (mean=2,64) although this difference is not significant.

There are significant differences among opinions of respondents from Bertoki (mean=2,8,), Hrvatini (mean=2,9), Sp. Škofije (mean=2,8), Koper (mean=2,6) and employees of the Port of Koper (mean=3,3). (Friedman $\chi^2 = 19,870$, df=6, Asymp. Sig. (2-tailed) =0,003)

There are some differences between the results of both surveys in that respondents grade their readiness higher in 2nd survey (mean=2,87) than in first survey (mean=2,6) although the difference is not statistically significant. There are statistically significant differences in opinion of respondents in Ankran (1st mean=2,4, 2ndmean=2,9, Wilcoxon Signed Ranks Test (Z)=-2,645, Asymp. Sig. (2-tailed) =0,008) and employees of the Port of Koper (1st mean=2,3, 1st mean=3,5, Wilcoxon Signed Ranks Test (Z)=-3,750, Asymp. Sig. (2-tailed) =0,000).

Table A 4/ 61
Comparison of results from different locations

Ranks		Test Statistics ^a	
	Mean Rank	N	
Ankaran	4,72	20	
Bertoki	3,40	Chi-Square	19,870
Hrvatini	3,28	df	6
Koper	3,50	Asymp. Sig.	,003
port of Koper	5,48	a. Friedman Test	
Sp Skofije	3,68		
Zg Skofije	3,95		

Table A 4/ 62
Correlations – age, employment and education

			Higher taxes	Separate waste collection	Lower energy consumption	Employment	Education
Spearman's rho	Higher taxes	Correlation Coefficient	1,000	,254**	,287**	-,120*	-,112*
		Sig. (2-tailed)	.	,000	,000	,023	,034
		N	360	358	357	360	360
	Separate waste collection	Correlation Coefficient	,254**	1,000	,425**	-,082	-,102*
		Sig. (2-tailed)	,000	.	,000	,114	,049
		N	358	375	372	375	375
	Lower energy consumption	Correlation Coefficient	,287**	,425**	1,000	-,154**	-,138**
		Sig. (2-tailed)	,000	,000	.	,003	,007
		N	357	372	374	374	374
	Employment	Correlation Coefficient	-,120*	-,082	-,154**	1,000	,312**
		Sig. (2-tailed)	,023	,114	,003	.	,000
		N	360	375	374	383	383
	Education	Correlation Coefficient	-,112*	-,102*	-,138**	,312**	1,000
		Sig. (2-tailed)	,034	,049	,007	,000	.
		N	360	375	374	383	383

** . Correlation is significant at the 0.01 level (2-tailed).

* . Correlation is significant at the 0.05 level (2-tailed).

			Separate waste collection	Age (rank)
Spearman's rho	Separate waste collection	Correlation Coefficient	1,000	,141**
		Sig. (2-tailed)	.	,006
		N	377	377
	Age (rank)	Correlation Coefficient	,141**	1,000
		Sig. (2-tailed)	,006	.
		N	377	383

** . Correlation is significant at the 0.01 level (2-tailed).

1st survey - People grade higher their answers to question c) *Would you be ready to lower your standard of living in order to protect the environment (simple food, less tourism, smaller use of luxurious items)?* (Mean =2,7). There are no significant differences among different groups, although students grade their agreement to this statement much lower than other respondents do.

2nd survey - Results of both surveys are the same (mean=2,7), although the differences among employees of the Port of Koper and residents in surrounding increased. A major difference is in the opinion of employees of the Port of Koper (1st mean=2,2, 2nd mean=3,5, Wilcoxon Signed Ranks Test (Z)= -4,290, Asymp. Sig. (2-tailed) =0,000). There is significant difference in opinion among people with different levels of education, where respondents with a high education (mean=3,1) and students (mean=3,0) grade their willingness to accept a lower standard of living higher than respondents with medium (mean=2,7), primary (mean=2,5) or no education (mean=2,7).

d) Are you collecting your waste separately?

1st survey - There is a correlation in the answers to question d) *Are you collecting your waste separately?* and age (Spearman's $\rho = 0,142$, Sig. (2-tailed) = 0,021) Respondents in the age group ranked their separate waste collection with the mean=2,31. People in aged 56-65 gave the highest ranking to separate waste for collection (mean=3,04) gave.

There is also a significant difference in the analysis of answers according to location. People in

Ankaran and Bertoki grade their existing separate waste collection scheme much lower than others (Mean=2,21), whereas people from the City of Koper (Mean=2,99) and employees of the Port of Koper (Mean=3,10) grade it much higher than others. The differences are statistically significant. (Friedman $\chi^2=20,297$, df=6, Asymp.sig.=0,002).

The reason for a high level of separate waste collection in the Port of Koper is due to their company policy. They have very strict rules concerning waste collection in the area of the Port and employees 'waste treatment' is randomly controlled. Violation of rules is penalized (offenders have to go around the Port area and pick up litter).

2nd survey - There is a significant difference between the results of 1st and 2nd survey regarding location. (Wilcoxon Signed Ranks Test (Z)=-4,290, Asymp. Sig. (2-tailed) =0,000). The biggest difference is Ankaran (1st survey mean=2,2, 2nd survey mean= 3,4) and in the Port of Koper in the 1st survey mean=3,1; 2nd survey mean= 4,0). The difference due to location is significant in general. (Friedman $\chi^2=31,230$, df=6, Asymp.sig.=0,000). Another significant difference occurs in the analysis according to employment status; where unemployed people rank their present separate waste collection scheme lower than other groups.) (Kruskal Wallis Test: $\chi^2=15,837$, df=3, Asymp.Sig.=0,001).

Table A 4/ 63
Comparison of results from different locations

Ranks		Test Statistics ^a	
	Mean Rank	N	
Ankaran	4,88		21
Bertoki	3,10	Chi-Square	31,230
Hrvatini	3,88	df	6
Koper	4,29	Asymp. Sig.	,000
Port of Koper	5,52	a. Friedman Test	
Sp Skofije	2,67		
Zg Skofije	3,67		

e.) If you were not collecting them separately until now - would you collect your waste separately in the future?

1st survey - People grade their answers to question e.) *If you were not collecting them separately until now - would you collect your waste separately in the future?* relatively high, which shows that they are aware of the problem (Mean=3,70). There is a correlation between the questions with the age of respondents, where respondents aged 26 – 45 display the highest willingness to collect waste separately. (Spearman's $\rho = 0,135$, Sig. (2-tailed) = 0,031) There is also some difference in the analysis according to residency, where people in Zg. Škofije grade their intention higher (mean =3,9) than other respondents, but the difference is not significant.

2nd survey - Results of the second survey are similar to the first one. There is a significant difference in the different employment groups (Kruskal Wallis Test: $\chi^2=10,255$, df=3, Asymp.Sig.=0,017). The pattern is similar as in question d/ - unemployed people (mean=3,8) rank their willingness lower than other employed people (mean=3,9) and students (mean=4,0).

Table A 4/ 64
Comparison of results from different locations

Ranks		Test Statistics ^a	
	Mean Rank	N	
2/ Ankaran	3,35		20
2/ Bertoki	3,98	Chi-Square	17,757
2/ Hrvatini	4,38	df	6
2/ Koper	3,50	Asymp. Sig.	,007
2/ Port of Koper	5,55	a. Friedman Test	
2/ Sp Skofije	3,80		
2/ Zg Skofije	3,45		

1st survey - Pattern in answers to question f.) *Are you recycling everything that is possible to recycle?* are very similar to the answers to questions d) and e). There is a correlation between people's opinion and their age, where the highest level of recycling is achieved by people in age group 56-65 (mean=3,17) (Spearman's $\rho = 0,135$, Sig. (2-tailed) = 0,031). There are also some differences in analysis according to employment status, where the lowest rate of recycling is achieved among students (mean=1,64) (Kruskal Wallis Test: $\chi^2=13,439$, Asymp.Sig.=0,004). Differences in analysis according to location show a similar pattern to d) and e), but are not significant.

2nd survey

There is a difference in opinion about recycling among respondents from different locations (Friedman : $\chi^2=17,757$, Asymp.Sig.=0,007). The average results from both surveys are similar, but we can see that there are positive differences in Ankaran, Bertoki, Sp. Škofije and Zg. Škofije and a negative difference in the City of Koper. We can conclude from series of answers about waste collection that separate waste collection and recycling are not well organized in some locations, but people are ready to collect waste separately and to recycle.

g.) Are you ready to use your car less in order to protect the environment if the public transport would be available?

1st survey - We can see from answers to question g.) *Are you ready to use your car less in order to protect the environment if public transport was available?*, that people are ready to consider the idea. There is a significant difference in opinions among employed, non-employed, retired people and students, where retired people show the greatest readiness to exchange cars for public transportation (mean=3,45) and students show the lowest (mean=2,64). (Kruskal Wallis Test: $\chi^2=8,161$, Asymp.Sig.=0,043).

2nd survey - Results from both surveys are very similar (mean=3,3) although the difference in opinion of respondents from different locations is statistically significant. (Friedman : $\chi^2=20,857$, Asymp.Sig.=0,002). The greatest difference is in the opinions of employees of the Port (1st survey mean=3,1, 2nd survey mean=3,6; Wilcoxon Signed Ranks Test (Z)= -3,591, Asymp. Sig. (2-tailed) =0,000).

There is a difference in the opinions of students and other groups, but this is not statistically significant.

Table A 4/ 65
Comparison of results from different locations

Ranks		Test Statistics ^a	
	Mean Rank	N	
Ankaran	3,83	Chi-Square	20,857
Bertoki	3,44	df	6
Hrvatini	3,78	Asymp. Sig.	,002
Koper	4,08	a. Friedman Test	
Port of Koper	5,78		
Sp Skofije	4,00		
Zg Skofije	3,08		

h.) Are you ready to lower your energy consumption?

1st survey - People graded answers to question h.) *Are you ready to lower your energy consumption?* with mean grade 3,32. There is a significant difference in opinion among male and female respondents, where women show a higher readiness to lower energy consumption. (Kruskal Wallis Test: $\chi^2=3,911$, Asymp.Sig.=0,048). There is also a significant difference

among students and other respondents, where students in middle school grade their readiness higher than others and students from university grade it lower than average. (Kruskal Wallis Test: $\chi^2=14,341$, Asymp.Sig.=0,014).

2nd survey - Results of the second survey are similar (1st mean=3,3, 2nd mean=3,4) to the first one except for opinions of respondents from the Port of Koper (1st mean=3,3, 2nd mean=3,8; Wilcoxon Signed Rank Test Z = -2,612, Asymp. Sig. (2-tailed = 0,009).

i.) Would you be ready to pay higher prices for some products, because the Port of Koper wishes to implement better environmental protection program.

1st survey - Respondents gave low ranking to this idea *i.) Would you be ready to pay higher prices for some products, because the Port of Koper wishes to implement a better environmental protection program.* The average grade is 2,06 and there are no significant differences among the groups of respondents, although people in Zg. Škofije did give the lowest grade.

APPENDIX 5: CALCULATION OF CRONBACH α

Questions	Resp 1	Resp 2	Resp 3	Resp 4	Resp 5	Resp 6	Resp 7	Resp 8	Resp 9	Resp 10	Si	Si2
Q4												
Reporters	5	2	1	4	4	3	2	3	3	3	1,15	1,20
Port of Koper	1	4	2	3	3	1	1	2	1	1	1,10	1,09
Green Party	4	1	3	5	1	4	4	4	4	4	1,35	1,64
Government	2	3	4	1	2	2	3	1	2	2	0,92	0,76
Experts	3	5	5	2	5	5	5	5	5	5	1,08	1,05
Q5	3	3	4	4	4	4	4	1	4	4	0,97	0,85
Q6												
Clean and healthy env.	5	4	2	3	2	3	2	4	5	5	1,27	1,45
Solid economy	4	5	5	5	5	5	4	3	2	1	1,45	1,89
Economic growth	2	3	4	4	4	4	1	1	1	4	1,40	1,76
Humane society	3	2	3	2	1	2	3	5	4	2	1,16	1,21
Freedom of speech	1	1	1	1	3	1	5	2	3	3	1,37	1,69
Q7	4	4	3	2	2	2	2	1	2	3	0,97	0,85
Q8												
Agriculture	1							1			0,00	0,00
Waste		5	2	3		2	2	3	5	4	1,28	1,44
Industry	5	2	1	2	5	5	5	5	4	3	1,57	2,21
Tourism			3	1	1		4		1	5	1,76	2,58
Port of Koper	4	1	5	5	4	4	3	4		1	1,51	2,02
Road traffic	2	4	4	4	3	3	1	2	2	2	1,06	1,01
Fire places	3	3			2	1			3		0,89	0,64
Q9												
Agriculture	1	0	0	0							0,50	0,19
Sewage outflow	4	4	4	3	3	1	4	5	5	4	1,16	1,21

Wastewater treatment	5	5	1	5		2	3		4	3	1,51	2,00
Tourism	0	0	2	1	2			2	1		0,90	0,69
Port of Koper	3	0	5	2	5	5	5	4		5	1,79	2,84
Shipping	0	2	3	4	4	4	2	3	2	1	1,35	1,65
Road traffic	0	3	0	0							1,50	1,69
Industry	2	1	0	0	1	3	1	1	3	2	1,07	1,04
Q 10												
Agriculture	2	2	2	1	2	1	1	1	2	2	0,52	0,24
Industry	3	3	1	2	1	3	3	4	4	3	1,06	1,01
Tourism	1	1	3	4	3	2	4	3	3	1	1,18	1,25
Port of Koper	5	4	4	3	4	5	2	2	1	5	1,43	1,85
Road traffic	2	5	5	5	5	4	5	5	5	4	0,97	0,85
Q 11												
a / Air pollution	3	5	2	3	3	4	2	4	1	4	1,20	1,29
b/ Marine pollution	4	4	4	3	4	4	3	3	1	4	0,97	0,84
c/ Soil pollution	3	5	3	3	3	4	4	3	0	4	1,32	1,56
d/ Use of chemicals in food	4	5	3	3	3	2	3	2	0	4	1,37	1,69
e/ Risk from nuclear power plant	2	5	1	1	1	3	1	2	0	4	1,56	2,20
f/ Radon in homes	3	5	1	1	0	0	2	0	0	4	1,84	3,04
Q 12												
a.) Air pollution	5	3	3	4	4	5	3	4	2	5	1,03	0,96
b.) Marine pollution	5	3	5	5	5	4	5	5	3	5	0,85	0,65
d.) Soil pollution.	4	3	3	3	4	4	3	3	1	5	1,06	1,01
c.)Waste production		3	5	4	5	5	4	5	1	4	1,32	1,56
e.) Noise generation	5	3	3	2	3	5	3	2	2	5	1,25	1,41
f.) Biological introduction of alien species	5	4	1	3	4	4	5	3	2	3	1,26	1,44
g.) Storage of hazardous materials	4	5	2	3	3	5	2	4	3	5	1,17	1,24
h.) Risk from accidents												
Oil spill	4	5	4	2	3	4	5	4	3	5	0,99	0,89
Ship accident	3	4	3	2	3	3	2	4	2	2	0,79	0,56
Accident in land transportation	4	4	3	3	4	3	3	4	3	2	0,67	0,41

Q 13												
a.) We believe too much in science and technology and too little in intuition and feelings.	2	3	2	2	3	2	1	2	1	3	0,74	0,49
b.) Modern science is causing more harm than good.	2	3	2	2	3	3	2	2	1	3	0,67	0,41
c.) Any change in environment, caused by human activity, no matter how scientifically founded, is harmful.	4	3	2	2	2	3	2	2	1	3	0,84	0,64
d.) Modern science will solve all environmental problems without us having to change our life habits.	2	3	2	2	2	4	1	3	2	3	0,84	0,64
e.) We worry too much about our future and environment and not enough about prices rates and employment at present.	2	2	2	2	4	4	2	3	1	2	0,97	0,84
f.) Nearly everything we do is harmful to the environment.	3	3	1	2	3	2	2	2	1	3	0,79	0,56
g.) People worry too much that the development of modern technological society will harm the environment.	2	3	1	2	2	2	2	3	2	4	0,82	0,61
Q 14												
a) Would you be ready to pay higher prices for goods in order to protect the environment?	4	4	3	3	4	4	3	1	1	2	1,20	1,29
b) Would you be ready to pay higher taxes in order to protect the environment.	4	4	3	1	4	4	4	1	2	2	1,29	1,49
c) Would you be ready to lower your standard of living in order to protect the environment (simple food, less tourism, smaller use of luxurious items)?	4	4	3	2	3	4	2	1	2	3	1,03	0,96
d) Are you collecting your garbage separately ?	4	4	2	1	3	4	2	2	1	2	1,18	1,25
e.) Would you collect your garbage separately ?				1	4	4	4	3	2	4	1,21	1,27
f.) Are you recycling everything that is possible to recycle?	4	4	3	1	1	4	2	1	1	1	1,40	1,76
g.) Are you ready to use your car less in order to protect the environment if the public transport would be available?	4	4	1	2	3	3	4	2	2	2	1,06	1,01
h.) Are you ready to lower your energy consumption?	4	4	3	3	2	2	4	3	1	3	0,99	0,89
i.) Would you be ready to pay higher prices for some products, because the Port of Koper wishes to implement better environmental protection program?	3	4	3	2	3	2	3	2	1	2	0,85	0,65

Totals =	186	200	161	156	179	191	171	162	127	189	Sum Si2 =	77,4
Mean	172,20				n =	62						
Standard deviation	21,56											
Variance	418,16				alpha =	0,83						