

Push-Pull DC-DC Converter with Planar Transformer for PV Application

Filipe Pereira, Abel Ferreira, Adriano Carvalho, António Martins, Vítor Sobrado
Faculdade de Engenharia da Universidade do Porto, Porto, Portugal
Email: {filipe, abelf, asc, ajm, vitors}@fe.up.pt

Abstract — There is a trend toward increasing the performance of power electronics converters used in photovoltaic systems. This paper presents the design and implementation of Push-Pull DC-DC converter. This converter typically integrates systems for photovoltaic (PV) applications. Is also presented the design of the high frequency planar transformer, which presents several advantages in relation to conventional transformer.

Index Terms — Photovoltaic energy, Push-Pull DC-DC converter, Planar transformer.

I. INTRODUCTION

Global demand for electrical energy is constantly growing. Along with the declining production of the dominating energy supplies since the industrial revolution, fossil fuels, there has been a growing interest in exploring renewable energies internationally. Among a variety of the renewable energy sources, photovoltaic sources have no supply limitations and are predicted to become the biggest contributors to electricity generation among all renewable energy candidates by 2040 [1].

The recent trends in the PV energy generating systems for improvement in their performance have increased the demand of power electronics converters to interface these systems. The push-pull converter, present in figure 1, is suitable topology in PV applications because the converter has advantages such as high voltage conversion ratio and low input current ripple. It also has two ground-referenced switches, which is easier to drive. The main limitation of this topology is the switches must be twice the input voltage. This converter makes use of a center-tapped high-frequency (HF) transformer to step-up the primary voltage and also to provide the galvanic isolation between the input voltage and output voltage [2].

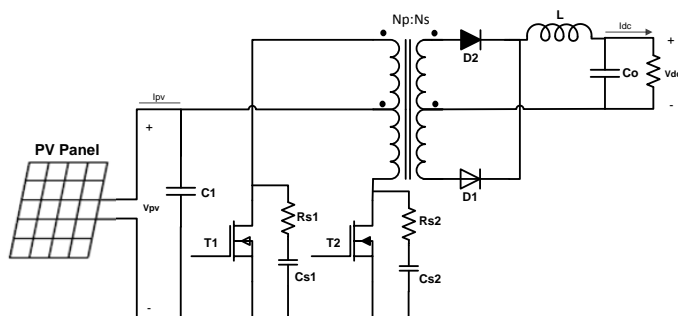

Fig.1. Schematic of the Push-Pull DC-DC Converter

The output–input voltage ratio as a function of the duty-cycle (D) and transformation ratio (a) is present in equation (1).

$$G_v = \frac{V_{dc}}{V_{pv}} = 2aD \quad (1)$$

II. PUSH-PULL DC-DC CONVERTER DESIGN

A. Planar Transformer

The planar transformer can be built as standalone components, with a stacked layer design or a multilayer PCB. The main advantages of planar transformer are: very low profile, excellent thermal characteristics, modularity and manufacturing simplicity and the use of higher switching frequency can result in passive component size reduction, which achieves higher power density in power converter [3].

When power converters operate at high frequency, the design difficulty for the transformer becomes much higher. The current density redistribution inside the winding wires (skin and proximity effects) strongly increases the copper losses.

The design of the planar transformer is based on an area product A_p approach. A_p is the product of the window area, A_w , by the core cross-section, A_c . Using power handling capability of the core, P_N , and equation (2) is possible calculate the area product [3].

$$A_p = \frac{P_N}{K_j k_u B_m J f} 10^4 \quad (2)$$

Where K_j is the waveform coefficient, K_u is the utilization factor, B_m is the maximum core flux density, J is the current density and f is the switching frequency.

Faraday's law is still used to calculate the required number of turns for the primary and secondary windings and can be expressed in equation (3).

$$N = \frac{V_{dc}}{K_j A_c B_{ac} f} 10^4 \quad (3)$$

The track width (wt) can be calculated using equation (4). where the spacing between the turns and the winding width are denoted by the symbols s and b_w [3].

$$w_t = \frac{b_w - (N+1)s}{N} \quad (4)$$

With equation (2), (3) and (4) it is possible to design the transformer according to the other system parameters, which are imposed by the requirements listed in Table I.

TABLE I
SYSTEM PARAMETERS

Symbol	Parameter	Rating
V_{pv}	Input Voltage Range	30-40V
P_n	Rated Power	250W
a	Transformer Ratio	2:30
f_{sw}	Switching Frequency	50kHz
V_{dc}	DC link Output Voltage	400V

The prototype of the HF planar transformer, present in the figure 2, is built using the core E64/10/50-3C90 with 2 pieces of the double layer PCB. Each primary winding has 2 turns divided into 5 tracks with the objective of dividing the current density for each turn. Each secondary winding has 30 turns. The spacing between the turns and the track width are the same, 0,3mm.

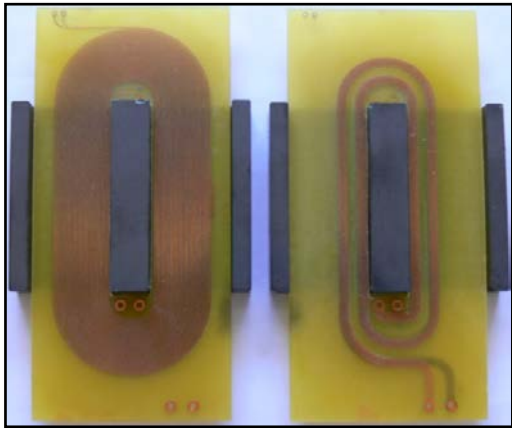

Fig.2. Prototype of the HF planar transformer

B. Prototype

Is show in Fig. 3 the laboratory workbench with the assembled prototype of the DC-DC power converter.

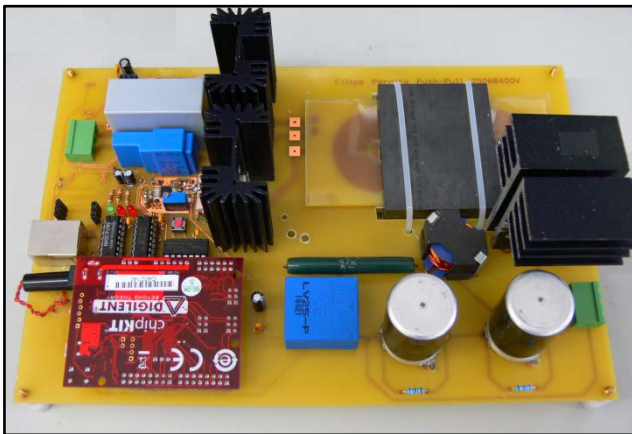

Fig.3. Prototype of the Push-Pull DC-DC Converter

III. EXPERIMENTAL RESULTS

The converter was implemented and tested in laboratory based on the microcontroller Chipkit 32Uno switching strategy in open loop with fixed duty-cycle. The system parameters used to design and test the push-pull converter are presented in table I.

In Fig. 4 shows the experimental waveforms the drain-to-source voltage V_{ds} of the switch S_1 and the current through the primary winding of the transformer.

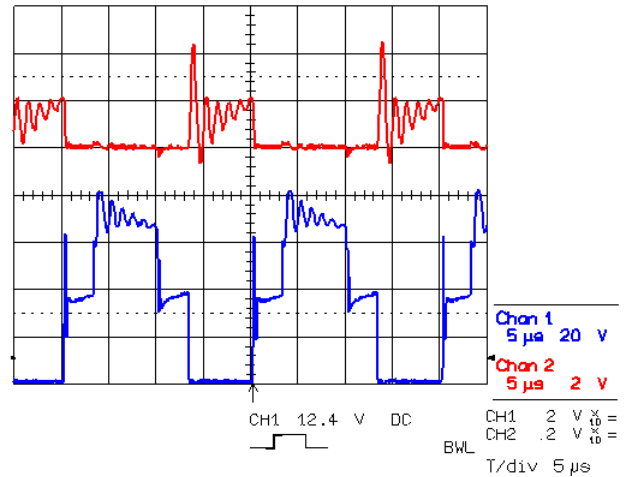

Fig.4. Experimental waveforms the V_{ds} and the current through the primary winding

The conditions of the test were 34V input voltage and fixed duty-cycle 35%, i.e., open-loop control in order to test only the part of the conversion of power the converter. The input voltage was increased to the output voltage of 350V.

In the experimental result is possible to observe several oscillations caused by the leakage inductances in the planar transformer. To overcome this problem, was used a snubber circuit to remove the high frequency spikes by having the capacitor collect the charge and then discharge through the resistor.

IV. CONCLUSIONS

This paper presents design and implementation of Push-Pull DC-DC converter. This topology is suitable in PV applications that require a high voltage gain between the input and output voltages and input current ripple.

The planar transformer offers many benefits over the conventional transformer in several aspects, such as in low profile, modularity and manufacturing simplicity, increased reliability, and power density of the power converter.

REFERENCES

- [1] European Renewable Energy Council, "Renewable Energy Scenario to 2040 - Half of Global Energy Supply," EREC.
- [2] Sharulnizam M. Mukhtar, Abd Rahman Mohd Saad, and N. H. Hanafi, "A high efficiency microcontroller-based step-up push-pull DC-DC converter for PV inverter," in Power and Energy (PECon), 2010 IEEE International Conference on, 2010, pp. 141-145.
- [3] Ferroxcube Application Note, "Design of planar power transformers," p. 16, 1997.