



Wayne State University

---

Wayne State University Theses

---

1-1-2017

# Reusable Medical Equipment Inventory Assessment At A Detroit Medical Center

Tannaz Khaleghi  
*Wayne State University,*

Follow this and additional works at: [https://digitalcommons.wayne.edu/oa\\_theses](https://digitalcommons.wayne.edu/oa_theses)

 Part of the [Industrial Engineering Commons](#), and the [Medicine and Health Sciences Commons](#)

---

## Recommended Citation

Khaleghi, Tannaz, "Reusable Medical Equipment Inventory Assessment At A Detroit Medical Center" (2017). *Wayne State University Theses*. 571.

[https://digitalcommons.wayne.edu/oa\\_theses/571](https://digitalcommons.wayne.edu/oa_theses/571)

This Open Access Thesis is brought to you for free and open access by DigitalCommons@WayneState. It has been accepted for inclusion in Wayne State University Theses by an authorized administrator of DigitalCommons@WayneState.

**REUSABLE MEDICAL EQUIPMENT INVENTORY  
ASSESSMENT AT A DETROIT MEDICAL CENTER**

by

**TANNAZ KHALEGHI**

**THESIS**

Submitted to the Graduate School

of Wayne State University,

Detroit, Michigan

in partial fulfillment of the requirements

for the degree of

**MASTER OF SCIENCE**

2015

**MAJOR: INDUSTRIAL ENGINEERING**

Approved By:

---

Advisor

Date

**© COPYRIGHT BY**

**TANNAZ KHAELGHI**

**2015**

**All Rights Reserved**

## **ACKNOWLEDGEMENTS**

I would like to thank my loved ones, who have supported me throughout entire process, both by keeping me harmonious and helping me putting pieces together. I would also like to express my sincere gratitude to my advisor Dr. Alper Murat for the continuous support of my master study and related research, for his patience, motivation, and immense knowledge.

# TABLE OF CONTENTS

Introduction.....	1
Literature Review.....	2
Proposed methodology.....	5
Assumptions.....	8
Tray Utilization Analysis.....	9
1. Tray Utilization Analysis Under One-Day SPS Turn-Around Assumption .....	9
2. Tray Utilization Analysis Under Two-Day SPS Turn-Around Assumption .....	14
Simulation model.....	18
Model Structure .....	20
Simulation Results .....	21
Challenges.....	29
Future Opportunities .....	29
APPENDIX.....	31
REFERENCES .....	39
ABSTRACT.....	41
AUTOBIOGRAPHICAL STATEMENT.....	43

## **LIST OF TABLES**

Table 1. Tray Utilization Analysis for one day SPS turnaround.....	14
Table 2. Tray Utilization for two day SPS.....	16
Table 3. % Avg Delayed Cases with Original Inventory and Modified one for Two .....	27
Table 4. % Avg Delayed Cases with Original Inventory and Modified one for One.....	28

## LIST OF FIGURES

Figure 1. Simulation Model Application in optimization view point of the project.....	8
Figure 2. Maximum number of tray 8925 used during one year. ....	12
Figure 3. Current Tray Utilization for top 10 highest rates .....	13
Figure 4. Tray Utilization for 2 day SPS turnaround.....	15
Figure 5. Patient Service level One day SPS vs. Two Day SPS.....	16
Figure 6. Tray Under-Utilization for One day SPS and two Day SPS turnaround.....	17
Figure 7. Tray Over-Utilization for one day and two day SPS turnaround .....	17
Figure 8. Minimum Tray Requirement for one day and two day SPS turnaround.....	18
Figure 9. Simulation model overview.....	20
Figure 10.RME tray shortages for high, low and lowest SPS level.....	22
Figure 11. RME shortage for Low SPS level .....	23
Figure 12. RME shortage for High SPS level.....	22
Figure 13.RME shortage for Lowest SPS level .....	23
Figure 14. Avg of RME shortage with original/ modified inventory .....	24
Figure 15. Avg of shortages with original and modified inventory.....	24
Figure 16. Avg of shortages.....	25
Figure 17. % Avg Delayed Cases for One day SPS .....	27
Figure 18. % Avg Delayed Cases for two day SPS .....	28

## Introduction

Nowadays there is an upward trend in designing efficient health care systems. Along with the increase in healthcare innovations and aging population, these systems are witnessing high rise in demand in almost all its services and equipment especially reusable equipment such as trays and case carts. Effective management of the operating room and costs of trays utilized by surgery department is one of the most executable approaches for lowering a high proportion of cost in healthcare supply chain with an improved cycle service level (CSL).

Because of some specific features of each operating room equipment such as perishability, being valuable and lifesaving, studying efficient ways to keep financial balances help healthcare systems increase their profit with maintaining at an acceptable level of patient satisfactory. This study tries to bring up some problems which are common in most healthcare SC flows and gives solutions to simply decrease some costs or risks with the same level of satisfaction. Such problems (as in this case study related to reusable medical equipment for operating rooms) are solved to satisfy several issues such as minimizing costs (specifically purchasing and holding costs) and maximizing availability, decreasing delays and bottlenecks for ORs it is more reasonable to consider multiple objectives simultaneously.

In 20<sup>th</sup> century considerable developments have been achieved in regards of healthcare supply chain management and inventory control. We will also focus on some new trends to reduce number of unnecessary trays and eliminating their corresponding costs in healthcare supply chain operations by reviewing Detroit VAMC case study (as real world problem) more precisely.



## Literature Review

The reusable instrument tray inventory and staff efficiency level balancing and its effect on operating room delay reduction have been intensively studied in the literature from decision expert's points of view. They used many operations research tools and decision support systems which are becoming more and more available to solve such problems. The operating room also known as the surgical suite can be resembled as the hospital's heart of operations. It possess the largest cost and at the same time the largest revenue source and its functionality is so critical in a sense that each healthcare system attempts to make almost all factors, which affect surgery schedules, controllable (whether they are controllable factors or uncontrollable). Factors (such as operating rooms, surgeons, and equipment), are controllable by which we can predict whether there will be any delays or not. However, patient arrival time is an example of an uncontrollable factor. Even in this case healthcare still will be able to predict through distributions being fitted to the historical data of this type of delay. Inventory control is another aspect of the studies as it directly affects both all departments' performances specially operating room and final costs. These studies enables hospitals to manage a huge portion of their costs and revenues and keep their CSL at an acceptable level. As a result one of the main benefits to be concluded from enhancing OR management is a better coordination between the demand for hospital and the existing resources such as: OR, surgeons, beds, nurses and more considerably reusable medical equipment. Hence, hospitals are faced with rationally using their resources to prevent underutilization of available time, and most importantly to avoid overtime (delays) and the increase in waiting lists.

In one of the studies conducted accordingly, the problem of scheduling elective surgery patients in the orthopedic surgery part of Habib Bourguiba hospital in Tunisia has been researched. In this study, two types of resources are taken into account: Operating Rooms and Recovery Beds.

The problem included optimizing the assignment of surgeries to OR's and planning the recoveries in order to avoid them in the OR's when no recovery bed is idle to use. The uncertainty in surgery and recovery durations and the capacity of resources affected a discrete event simulation model for analyzing the results. A knapsack model is represented to pick operations to be scheduled in the proposed day. By a mixed integer programming model these operations are assigned to the different operating rooms with the aim of wisely utilizing the operating rooms. Secondly, a discrete event simulation model is proposed for evaluating the global performance of the proposed model by a simple comparison. [1] This study shows an excellent example of using simulation for analyzing data in a better way as in our study we used simulation model for testing and analyzing results under conditions which help bring more precision and accuracy by simulating events and use surgery and sterilization duration estimations to add more variability.

Another research has been conducted around operation room however they specified their studies in some ways. It studies the problem for a local public hospital that adopts a block time scheduling scenario for only elective surgical cases. Emergency cases have their dedicated ORs; thus are not considered. However in our study add-on and emergency cases are assigned to their dedicated ORs and will be considered and affect our results. Basically they studied expected operating rooms under and over utilization and tested the results over different scenarios: 1. the impact of transferring surgical cases from a busy to a free operating room, 2. the effects of cancelations and of reducing the planned workload, 3. the usefulness of mixing surgical cases versus separating them by type. This paper also develops a simulation model for each strategy to compare the model's output and calculate the utility of each strategy based on statistical concepts. Some purposed suggestions by them are as follow: 1. based on the OR over and underutilization, they suggested cancel surgical cases which start after the closing time of the operating rooms. 2.

Since cancellation isn't a sensible way, it is better to reduce the workload planned at the off-line operational level to 90% of the Operating room's capacity [3]. According to the variability of the OR completion times, it is sensible to adopt a single queue for all surgical cases [4]. But in some cases that this is infeasible from a managerial point of view, mixing surgical cases is preferable to separating them by type unless the hospital further decreases the number of minor cases assigned to the operating rooms. Finally, the transfer of the last surgical case from a busy OR to a free one reduces the range of OR completion times. [2] Their study were successful since they benefit from the feature of simulation and brought different scenarios to compare the data and improve their decision making process through the outputs. Our study tests the effects of 4 scenarios and picks the best output which reveals less number of delays and tray shortages.

In another study, Dexter F, Macario A, O'Neill developed a scheduling strategy that balances the OR manager's requirement to reduce staffing costs and the needs of patients and surgeons for flexibility in choosing the dates and times of cases. They used computer simulation to evaluate their scheduling strategy. According to their scheduling trend, surgeons and patients

- (i) can schedule the case into any overflow block within 2 weeks;
- (ii) can only schedule the case into a "first case of the day" start time more than 2 weeks in the future if there is not enough open time for the case within 2 weeks;
- (iii) must schedule the case to be done within 4 weeks; and
- (iv) are encouraged to perform the case on the earliest possible date.

Staffing costs were lowest when the OR manager did not incorporate surgeon and patient preferences when scheduling cases into overflow block time. The strategy they developed provides surgeons and patients with some flexibility in scheduling, while only increasing OR staffing costs slightly over the minimum costs achieved when the OR manager controls scheduling. [7]

Correspondingly staffing costs can vary in our research as we analyze the data for high, low and lowest SPS staff level and we can get a control over staff efficiency level and their corresponding costs.

In next research the issues of ORs scheduling are divided into three related sub issues: 1. The Case Mix Problem (CMP), 2. The Master Surgery Scheduling Problem (MSSP), and 3. The Surgery Scheduling Problem (SSP). CMP refers to the time of a resource (e.g., ORs) allocated to each surgical specialty which aims to minimize the total costs. This stage is out of handling and is controlled by hospital management. In MSS problem, the ORs time chart is allocated to these surgical specialties over the scheduling horizon (typically, a week) to maximize resources utilization. SSP refers to assigning each surgical case a start time, a day, and an OR with the target of minimizing the waiting time and maximizing resources utilization. This paper reviews these problems and represents a research framework for an integrated planning method for the three problems. [3]

On 1968 Barnoon and Wolfe studied the advantages and disadvantages of various schedules for operating rooms by the use of a Simscript simulation. This tool is designed in a way that it assigns ORs, anesthetists, and nurses for each case when they are available. A report of the performance of the system includes delays for facilities and personnel. Input variables consist of actual data or are generated from their probability distributions by the Monte Carlo technique. [10]

## **Proposed methodology**

As briefly explained in the previous sections, in this study we proposed an analytical model to predict minimum tray requirement by which we can reach the lowest level of delays to the surgeries. In this regard, we used Matlab in order to sort the data based on surgery dates and count the number of trays used in one day based on two assumptions, one-day and two-day SPS

turnaround. In one-day SPS turnaround we assume that all the trays needed for next day surgeries will be ready 24 hours ahead while in two-day SPS assumption trays will be ready after next day. The inventory will be adjusted based on the results from this analysis and the adjusted inventory levels will be fed to simulation to test the results and conclude based on the outputs. We developed a discrete event simulation model with multi functions which mimics the behavior of the operating rooms, sterilization department and other departments which affect directly or indirectly the flow of trays in the hospital. Simulation model has the capability of flowing RME trays once with sequencing trays by prioritization based on future demand in sterilization department and the other time with sequencing trays in sterilization process based on FIFO system. Furthermore we take SPS staff efficiency into account when we consider daily tray utilization rates and maximum tray utilization in a year with two assuming one-day and two-day SPS turnaround and the simulation model is designed for high, low and lowest SPS staffing level to reveal the effect of the staff efficiency on delays and shortages based on mentioned scenarios. Therefore we need to run simulation for 120 times as we run the model with 4 scenarios and for 5 sampled schedules. Looking at results that come out of both approaches for sequencing help analyze how sequencing affects our two objectives, waiting time and tray utilization. Briefly in this study we try to answer the following research questions given the sample of one year surgery schedules:

1. What is the current utilization level of RME trays?
2. Predict the minimum/Required level of RME trays in the inventory under one-day vs. two-day SPS turnaround condition?
3. How does sequencing trays in SPS affect the shortage level of RME and delays?

For achieving the above mentioned goals, initially we constructed a simulation model using Arena Simulation Software V.13. Put of 270 scheduled days and 4 block times (for each season,

every 90 days, we have a unique pre-defined block time.), a set of data need be chosen randomly from complete one-year data set of surgery schedules for Arena run. Sample selection system is designed in access database since the data source for Arena to read input data is accdb. file format. Also as each block time represents a completely different scheduling format we decided to choose our sample schedules from one block time to be able to consider all scheduling policies and resource availability conditions are the same for all sample schedules. Each block time (with 90 days of schedules) contains 18 Mondays, 18 Tuesdays, 18 Wednesdays, and so on. We randomly pick one weekday from 18 weekdays to make surgery schedule sample as simulation input and represent the results under certain conditions. Then given the output data we will be able to compare the effect of the SPS efficiency, tray sequencing and FIFO system for decontamination and one-day SPS or two-day SPS on delays and tray shortages and make decisions based on SPS efficiency and inventory level usage. These outputs also determine the delays for each surgery based on specified reasons. This output enables us to handle the delays and make more efficient decisions. In the following figure the overall mechanism of this study has been shown. The simulation model acts as the black box which is fed with some sample scenarios and we can expect the targeted results such as waiting time and tray utilization status in the system for further optimization process.

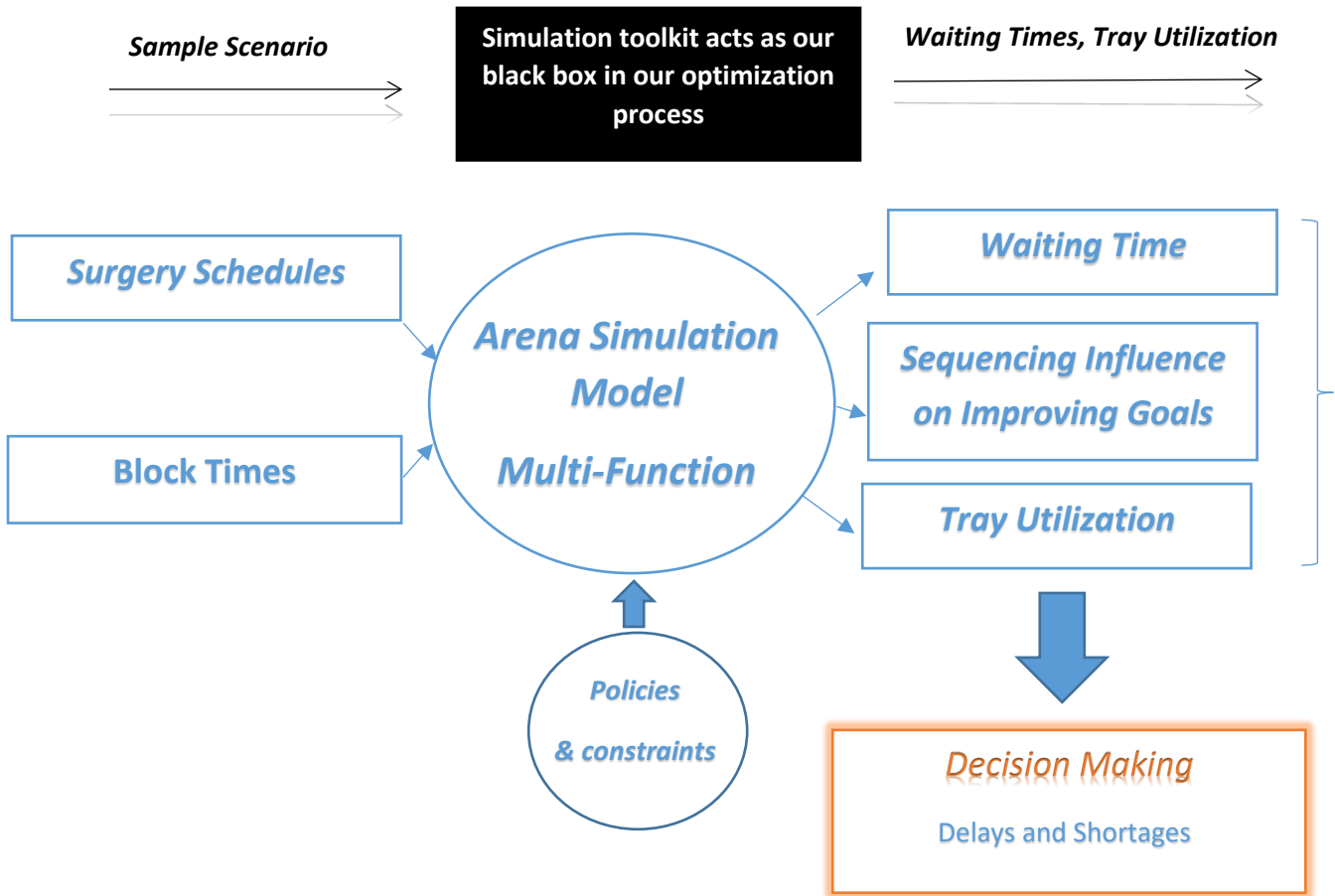

Figure 1. Simulation Model Application in optimization view point of the project

## Assumptions

We have approximately 4 block time charts in which there are 270 data sets of daily surgery schedules (from 01/2013 up to 01/2014) provided by VAMC. By each simulation run with a unique schedule outputs will be analyzed and interpreted into delays of the surgeries and consequently delays for patient. However with lack of information about other types of pre-operation delays we can only get delays due to RME in each replication. The delay types in the model are as follows:

1. Delays occurred due to tray is not available in inventory and its being processed in decontamination area. We also predict a duration until it gets cleaned and get ready for the surgery.
2. Delays occurred due to tray is not available in the inventory and its being processed in the sterilization area.
3. Delays occurred due to tray is not available in either SPS or inventory and its being utilized in the surgery room.

Simulation runs based on FIFO system (first Tray comes out of OR first goes to SPS for sterilization) in the first attempt of run in 10 replications. Second we will run based on sequencing trays by prioritization logic with the same number of replications that is proposed for first attempt. By default, we will assume that all the required trays get ready a day before the surgeries (as VAMC policy). Then we count minimum tray inventory needed. On the other hand, we are going to test the inventory level by assuming 2 days for SPS turnaround time for preparing the trays and count minimum inventory level requirements. Last assumption is that SPS department is running 24 hours every day in VAMC of Detroit.

## **Tray Utilization Analysis**

### **1. Tray Utilization Analysis Under One-Day SPS Turn-Around Assumption**

Tray Utilization Analysis is a Matlab based analysis by which we tried to get a common view over the utilization of the trays by surgery units during past year. We counted total number of each tray used per day based on historical data of surgery schedules by Matlab:



```

load DET;

[SortedDateOfOperation, SortOrder]=sort(Date); %Sort the Date of Opeartion in ascedning
order
RMETrayCode=RMETrayCode(SortOrder); %Sort the RMETrayCode based on SortOrder
UR=sort(unique(RMETrayCode(RMETrayCode>0)));

[~,~,a]=unique(SortedDateOfOperation); %Find the unique values order

D=zeros(max(a),1); %0 matrix

for j=1:max(a);
    D(j)=numel(a(a==j)); % we count number of dates that are same, for example if a==1 we
count number of 1s which is symbol of day 1
end

D=cumsum(D); %cumulative day function

RMET{1}=sort(RMETrayCode(1:D(1))); % because we have not matrixes with index 0, so we
separtted the first element from others.
URMET{1}=unique(RMET{1}); %Finds the unique trays in each surgery date
C{1} = hist(RMET{1},URMET{1});
Final{1}=[ones(size(URMET{1})) URMET{1} C{1}'];

for j=2:max(a)

    RMET{j} = sort(RMETrayCode(D(j-1)+1:D(j)));
    URMET{j} = unique(RMET{j});
    C{j} = hist(RMET{j},URMET{j});
    Final{j}=[repmat(j,size(URMET{j})) URMET{j} C{j}'];

end

counter=zeros(270,1);
for j=1:size(UR)
    for i=1:1:size(Final,2)

        temp=find(Final{i}(:,2)==UR(j));
        if ~isempty(temp)
            counter(i,j)=temp;
        else
            counter(i,j)=0;
        end
    end

    figure(j);
    bar(1:270,counter(:,j)); %returns the charts

end

```

Since we assume that, as VAMC policy, the trays will get ready a day before the scheduled date of surgery we can conclude that for each tray maximum value of total number of trays per day during 270 days of data set will be mostly the maximum number of trays they need to carry as their inventory during one year.

As an example:

✓ First day of surgery:

- First surgery: {trays: A,A,B,A,C},
- Second Surgery: {trays: A,A,A,A,B},
- Third Surgery: {trays: A,B,C,B,C}.

Assuming that the trays need to get ready for the surgery a day before it, in this case they need at least 8 # of tray A, 4 # of B, and 3 # of C.

✓ Second day of surgery:

- First surgery: { A,B,A,C} ,
- Second Surgery: {A,A,B} ,
- Third Surgery: {A,B,C,C}.

Again assuming that the trays need to get ready for the surgery a day before it, in this case they need at least 5 # of tray A, 3 # of B, and 3 # of C.

Day \ Tray	A	B	C
1	8	4	3
2	5	3	3

Let's assume that we have 10 number of tray type A, 6 number of tray B, 3 number of tray C in the inventory. Therefore under our assumptions we have 2 from A and 2 from B redundant in the inventory.

**Mitigation will take place if max number of tray utilization in the whole year is less than the number of trays in the inventory**

We have also another scenario in which some of SPS case cart preparations at the same day of surgery can be done. In this case the maximum number of tray utilization during 2013 will not be a sensible core index for our calculations and decisions and when we study the data regarding VAMC of Detroit we won't need to consider this scenario since currently their policy rejects this assumption.

Considering that we have the same schedule (as previously defined) we can level the inventory for tray A to the number of 4 trays in the storage if SPS reacts highly responsively in decontaminating, sterilizing and preparing the case carts for next surgery at the same day.

Finally, we need to show the utilization of each tray in a separate graph (Axis X: number of days, Axis Y: utilization percentage per day). Basically we will need to analyze utilization for 71 unique trays. As an example the graph for tray number 8925 is as following:

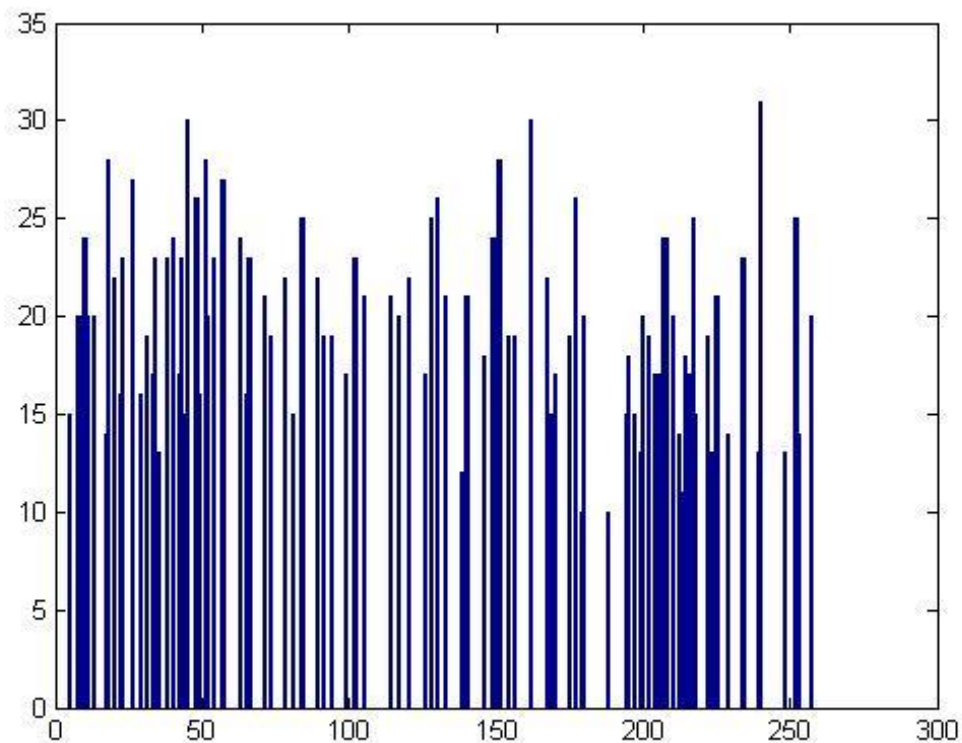

Figure 2. Maximum number of tray 8925 used during one year.

The illustration of all trays utilization can result in 71 graphs (one graph for each tray) therefore the results for top 10 trays with highest average utilization rates can be illustrated in one graph as following:

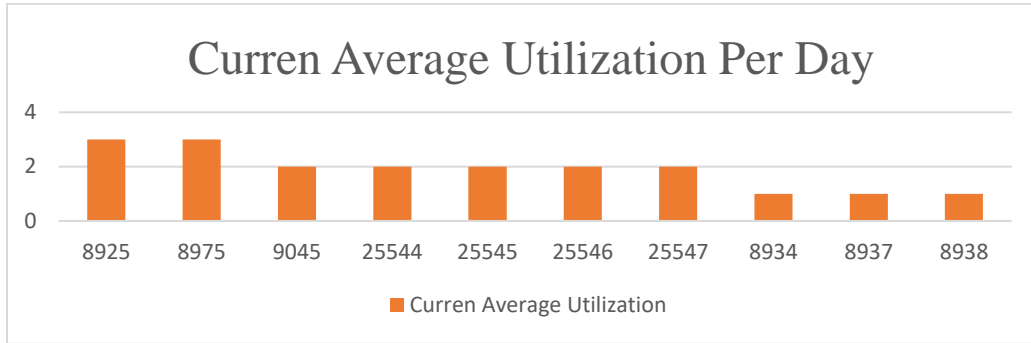

Figure 3. Current Tray Utilization for top 10 highest rates

We analyzed the data as we explained about it through an example and derived to the following table which shows the results more precisely.

RME Tray Code	Inv	Max # of Trays Used	Excess # of Trays	max % of inventory used	%				
					Aimed Service Level	% Tray Under-Util Measure	% Tray Over-Util Measure	% Real Service Level	New Inventory
9045	5	15	-10	300.0	100	0.0	200	0	15
25544	3	15	-12	500.0	100	0.0	400	-20	15
25545	6	15	-9	250.0	100	0.0	150	10	15
25546	18	15	3	83.3	100	16.7	0	100	18
25547	3	15	-12	500.0	100	0.0	400	-20	15
8975	26	11	15	42.3	100	57.7	0	100	26
8925	28	10	18	35.7	100	64.3	0	100	28
8974	19	9	10	47.4	100	52.6	0	100	19

8979	18	9	9	50.0	100	50.0	0	100	18
8934	4	8	-4	200.0	100	0.0	100	60	8

*Table 1. Tray Utilization Analysis for one day SPS turnaround*

Based on this analysis we also can conclude that tray code 25544 and 25547 owns the highest rate of over-utilization during one year such that they show highest shortage rates, 12. For one day SPS turn around the percentage of maximum inventory utilized per day has been calculated. The results depict that for fulfilling 100% service level we need to afford utilizing trays more than what we keep as inventory. As an example for tray code 25545 maximum number of tray being used in a day during a year is 15 trays which means in the given schedule there is surgery day schedule by which this tray was used 15 times. On the other hand the inventory count for the mentioned tray is only 6. Under one-day SPS turn-around assumption we need to keep at least 15 trays of the code 25545 to be able to avoid cancellations and delays and reach 100% patient service level in hospital's surgical unit.

Referring to the table.1 for some of the trays we have under-utilization equal to zero which means the hospital has been either over-utilized the trays (or used 100% of the tray inventory which is ideal) and as a result delays and cancellations occurred frequently based on given schedule.

## **2. Tray Utilization Analysis Under Two-Day SPS Turn-Around Assumption**

In second part of Tray Utilization Analysis, total number of trays used per two consecutive days have been counted for each unique tray. Under assumption of the trays being used today will be ready the day after tomorrow, we can conclude that for each unique tray maximum value of total number of trays per two-days during 270 days of data set will be mostly the maximum number

of trays they need to carry as their inventory during one year. Also the trays utilization results can be illustrated by the following graph:

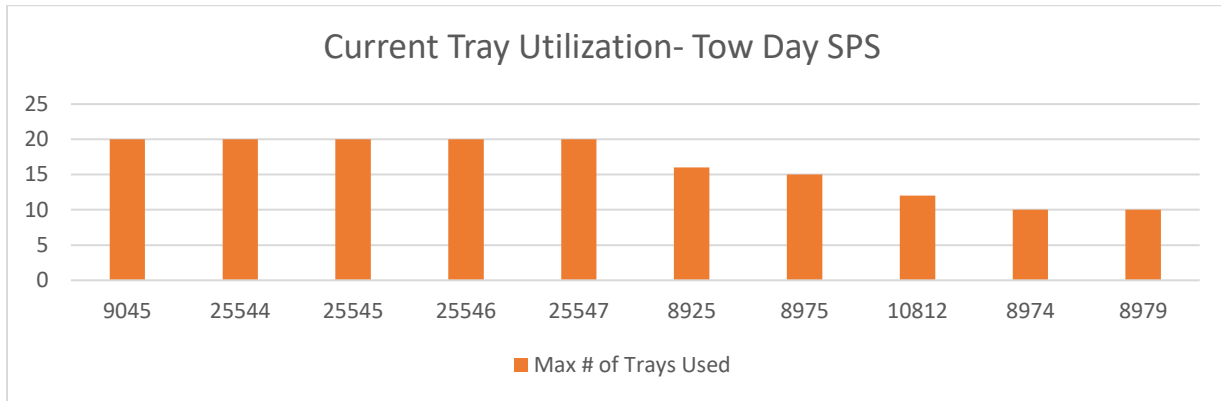

Figure 4. Tray Utilization for 2 day SPS turnaround

The following table shows the details of this analysis and further we can depict the charts for under-utilization and over-utilization based on one-day and two-day analysis.

RME Tray Code	Inv	Max # of Trays Used	Excess # of Trays	% max of inventory used	% Aimed Service Level	% Tray Under-Util Measure	% Tray OverUtil Measure	% Real Service Level
9045	5	20	-15	400.0	100	0.0	300	-50
25544	3	20	-17	666.7	100	0.0	567	-70
25545	6	20	-14	333.3	100	0.0	233	-40
25546	18	20	-2	111.1	100	0.0	11	80
25547	3	20	-17	666.7	100	0.0	567	-70
8925	28	16	12	57.1	100	42.9	0	100
8975	26	15	11	57.7	100	42.3	0	100
10812	7	12	-5	171.4	100	0.0	71	50
8974	19	10	9	52.6	100	47.4	0	100

8979	18	10	8	55.6	100	44.4	0	100
------	----	----	---	------	-----	------	---	-----

Table 2. Tray Utilization for two day SPS

For two day SPS turn-around maximum percentage of inventory utilization been calculated for each tray. The results shows that for fulfilling 100% service level we need to afford utilizing trays more than what we keep as inventory in most of the cases. As an instance for tray codes 25544 and 25547 maximum number of tray being used in two consecutive day during a year is 20 trays which means in the given schedule there are two consecutive surgery days by which this tray was used 20 times.

On the other hand the inventory count for the mentioned tray is only 3. Under two-day SPS turn-around assumption we need to keep at least 20 trays of them in the storage to be able to avoid cancellations and delays and reach 100% patient service level in hospital’s surgical unit. With current level of inventory of this tray we are able to fulfill -70% of service level (which means absolute dissatisfaction of patients and repetitive delays and cancellations occurrence regarding the surgical cases that need this type of tray). Referring to the table.2 for some of the trays, we have under-utilization equal to zero which means the hospital has been over utilized the trays and as a result delays and cancellations occurred frequently based on given schedule and two-day SPS turnaround time. Patient Service levels for one day and two day SPS turnaround is illustrated as follows:

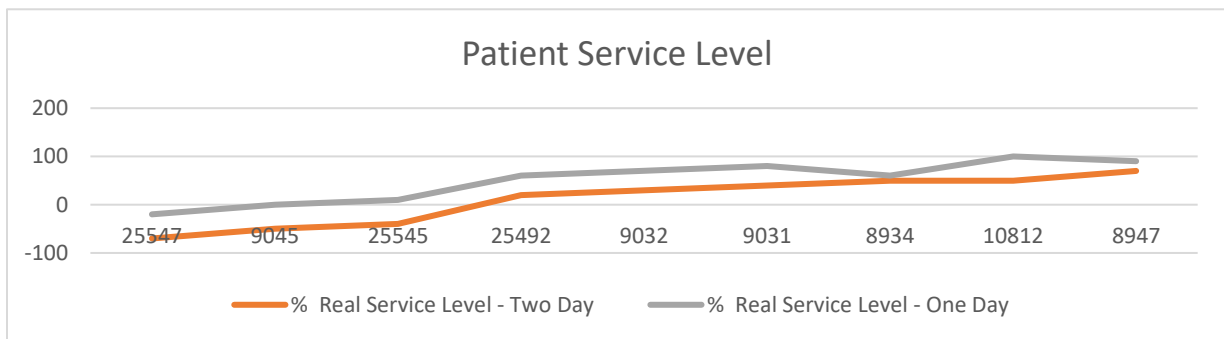

Figure 5. Patient Service level One day SPS vs. Two Day SPS

AS shown in table.1 and table.2 the results can be shown in one graph for comparing over-utilizations and under-utilizations of two assumptions.

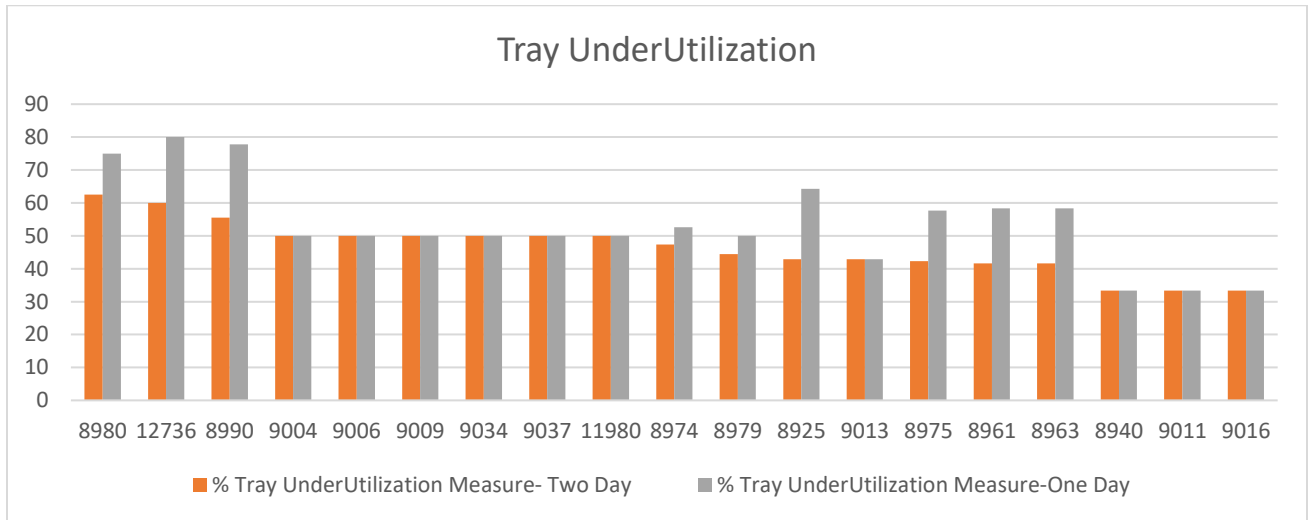

Figure 6. Tray Under-Utilization for One day SPS and two Day SPS turnaround

For trays showing high rates of under-utilization such as tray code 8980, 12736, and 8990 we recommend that hospital decrease the level of inventory to avoid holding costs and increase their final profit.

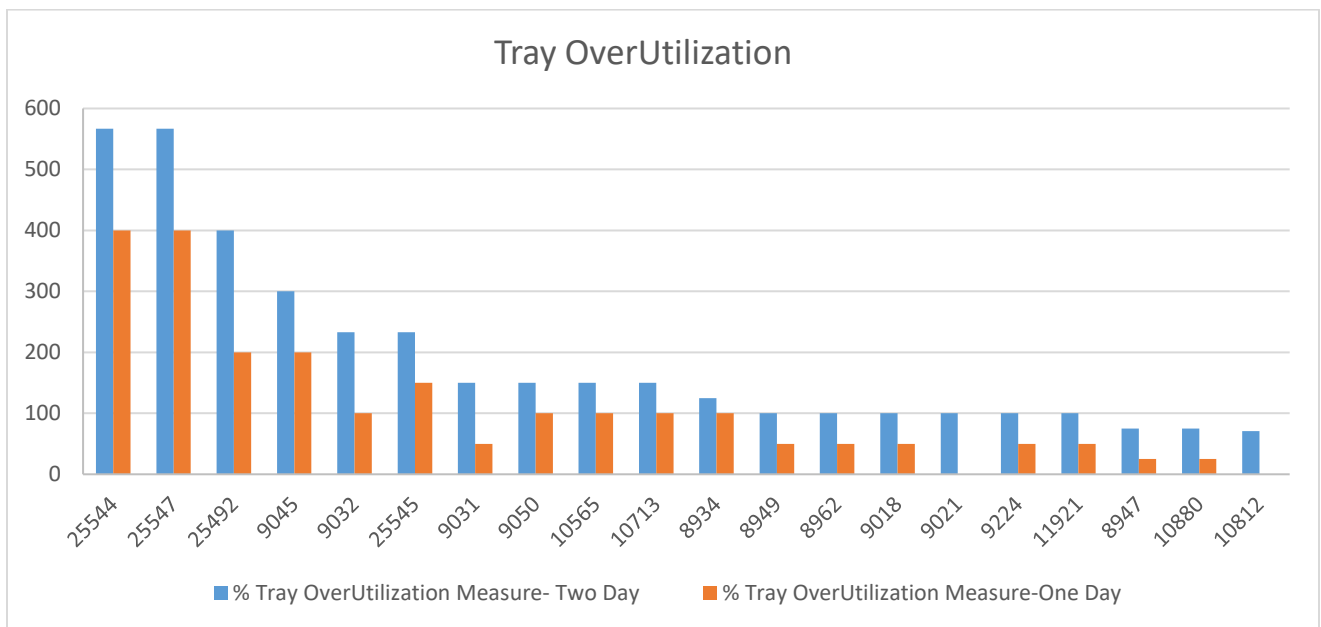

Figure 7. Tray Over-Utilization for one day and two day SPS turnaround



Tray code 25544, 25547 and 9045 show high rates of over-utilization which means hospital should either buy more trays or use loaner trays to decrease the shortages. They also can change their scheduling policies and allow scheduler use only up to highest level of inventory count for these trays to be used in one/two days.

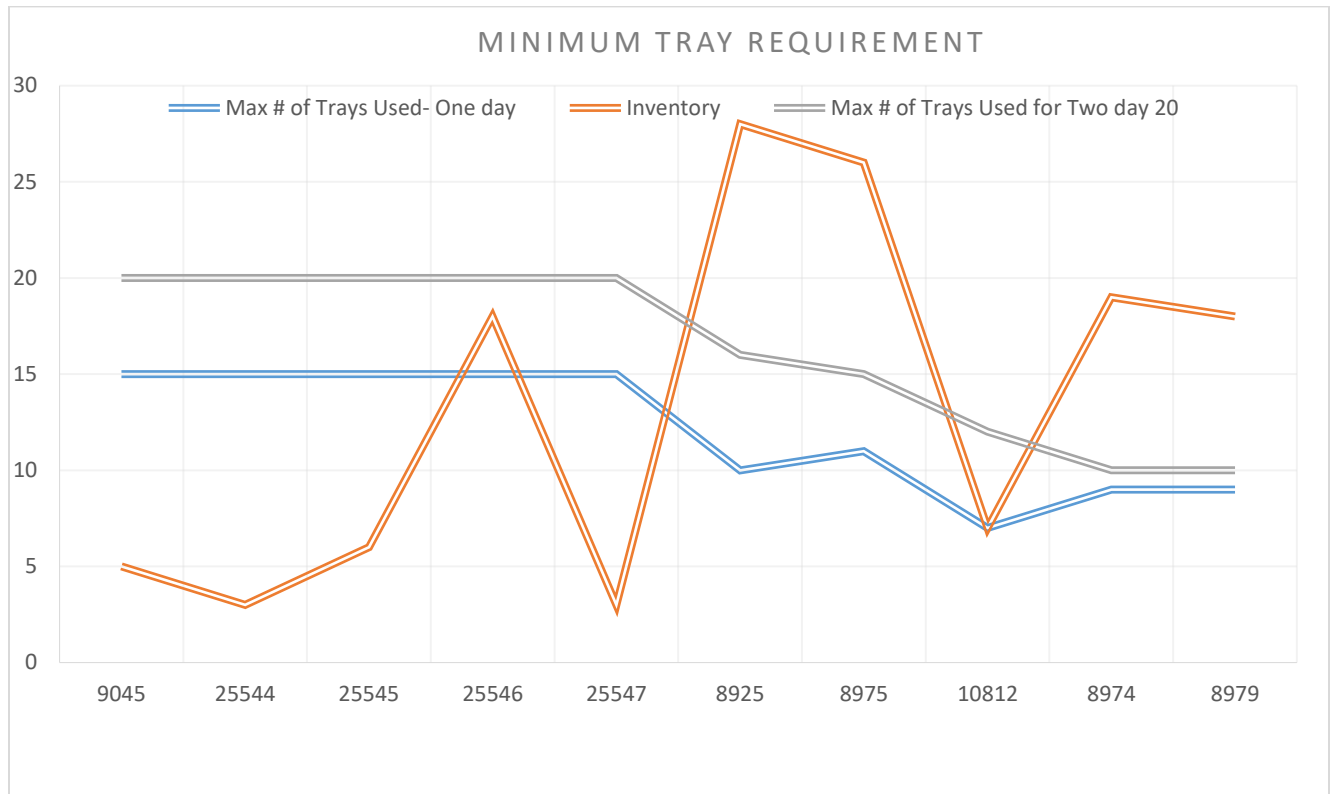

Figure 8. Minimum Tray Requirement for one day and two day SPS turnaround

The minimum requirement for trays for both assumptions in this graph shows the inventory level fluctuation if we consider them as new inventory levels for both analysis.

## Simulation model

The simulation model is a tool that we can get the outputs out of processing some possible scenarios of block times by running it with different number of replications. The proposed model consists of nearly all departments affecting RME tray utilization and bottlenecks such that helps

the model output more reliable. The integrated discrete event simulation model is well equipped with high flexibility and configurability features to meet different facility needs and workflows. These departments are Surgery Units, Sterilization, Storage and Podiatry Clinic. We tried to apply almost all of VAMC policies regarding all these departments specially surgery department such as “partial case cart assembly logic” that will be explained completely in the next chapter. This model has the capability of running 5 days of surgery schedule. Required data regarding the delays occurred to the surgeries in this period has been provided so that we can compare our stochastic results of running the model with those real results. However the historical data of delays is not a complete set of data, therefore we can rely on them just in purpose of comparing them after running the model. SPS staff schedules are predefined in simulation structure for past year (the period that surgery schedules conducted) to run the model with accurate decontamination, prep room and case cart preparation area staffs schedules. Also we proposed three SPS staff levels, high low and lowest, to depict the effect of staffing level on delays and shortages by running the model with different SPS staff levels. Surgery, decontamination and sterilization durations are estimated through Easyfit software and being used in simulation model. The model logic also involves two SPS prioritization methods which also enables us to study the effect prioritization on surgery delays and tray shortages in each schedule. These specifications help us simulate the events the reality. Also, for achieving the highest accuracy level of Arena results involving Censitrac data in future will enable us benefit from historical data of intellectual perception of trays location and utilization at the time we run it. We run the model with each data set to test different alternatives that we aim to suggest to mitigate tray inventory levels after we calculate tray’s utilization percentage over a year.

March  
14  
2013  
Thursday  
00:00:00

## VAMC Surgical Tray/Tray Demand Flow

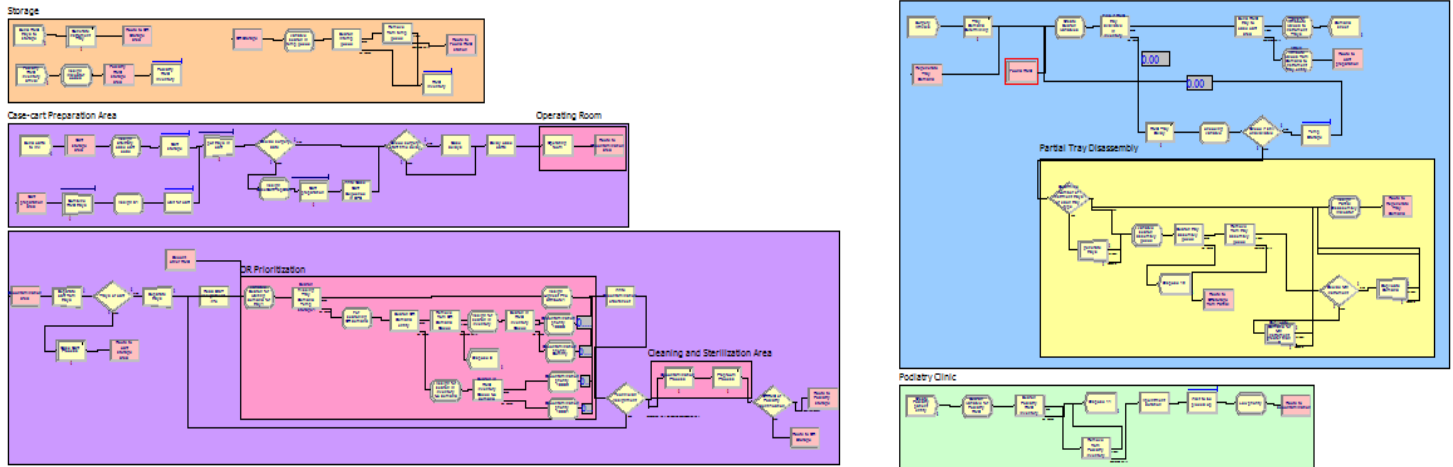

Figure 9. Simulation model overview

## Model Structure

Proposed simulation model contains Sterilization Processing Department, Surgical Units, Storage and Podiatry Clinic. There are four types of entities: patient, instrument tray, instrument tray demand, and case cart flowing in the simulation system. The model starts with creating required inventory of instrument trays and send them to the storage department. The demand for each tray based on the surgery schedule is being read from an input table and turns to its corresponding instrument tray if the model could find it in the inventory. For the tray demands that cannot be found in either Sterilization or Storage department up to one hour after scheduled start time of the surgery, simulation model will remove the whole corresponding surgical case cart and its belongings from Case Cart Preparation Area (This department prepares the case carts and send them to surgical units) and returns them to the storage. As a result the case will be cancelled for the scheduled start time and date. The process of removing case cart from Preparation Area is

called “partial case cart assembly logic”. After the case carts are used in surgical rooms they need to be processed in sterilization department. Therefore such case carts will be sent to Decontamination Area, first to be manually cleaned then to be washed in washing machines. The “Prioritization of trays” takes place in this stage. We either choose to run the model with giving each tray a specific priority based on the demand for it in decontamination area or run with FIFO system of the trays for decontaminating. After decontamination they need to be sterilized and reassembled in Preroom Area. Decontamination and Preroom time for each tray is different from another and they are being defined by two distribution through analyzing historical decontamination and Preroom time for trays. Finally sterilized trays will be sent to Storage department and will be stored them until next demand calls them. Also in the simulation we used surgery duration as normal distribution with mean of fixed pre-defined duration of the surgery and standard deviation of 0.2.

## **Simulation Results**

- **What is the effect of SPS staff level on RME tray shortage and case delays?**

As is shown in figure 10, different SPS staff level can affect the RME shortages and the effect can be analyzed in different ways due to the management preference. High SPS level is showing considerable less shortage for three trays but for others the difference between Low SPS shortage and high SPS shortage is not a lot. We can conclude that high SPS level might decrease the shortages for all trays but we have to take high staffing costs into account and based on that we can decide if high SPS level is profitable or not. Also it depends on management decision to

choose high patient service level and utilize high level of SPS staff or choose to avoid high costs of SPS staff and decide to use Low SPS.

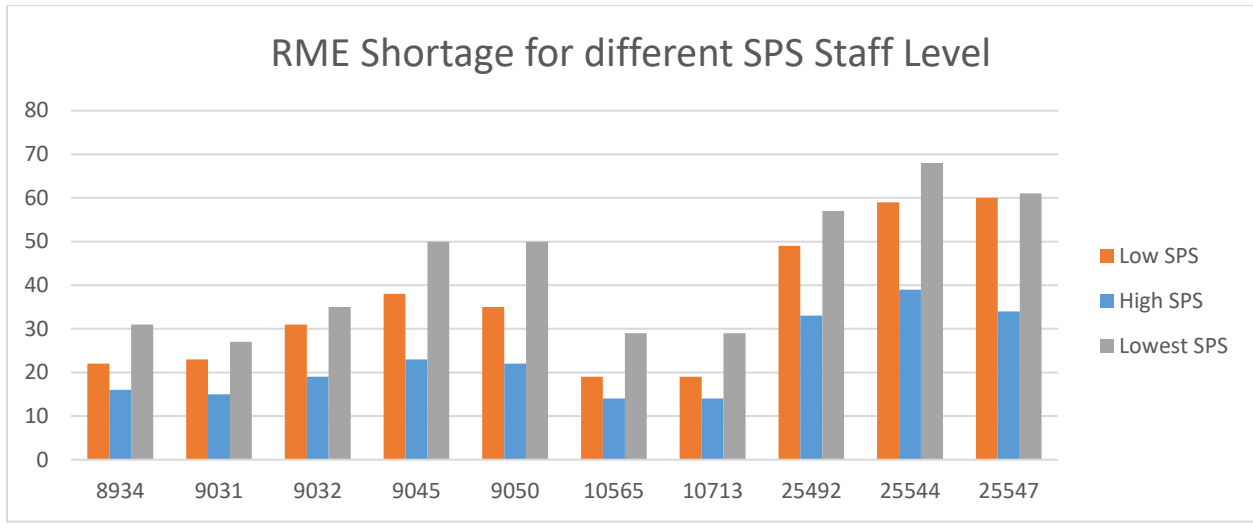

Figure 10. RME tray shortages for high, low and lowest SPS level

- **How does sequencing trays with custom prioritization strategy in SPS affect the RME tray shortage and case delays?**

As is illustrated in following three graphs customized prioritization decrease tray shortages.

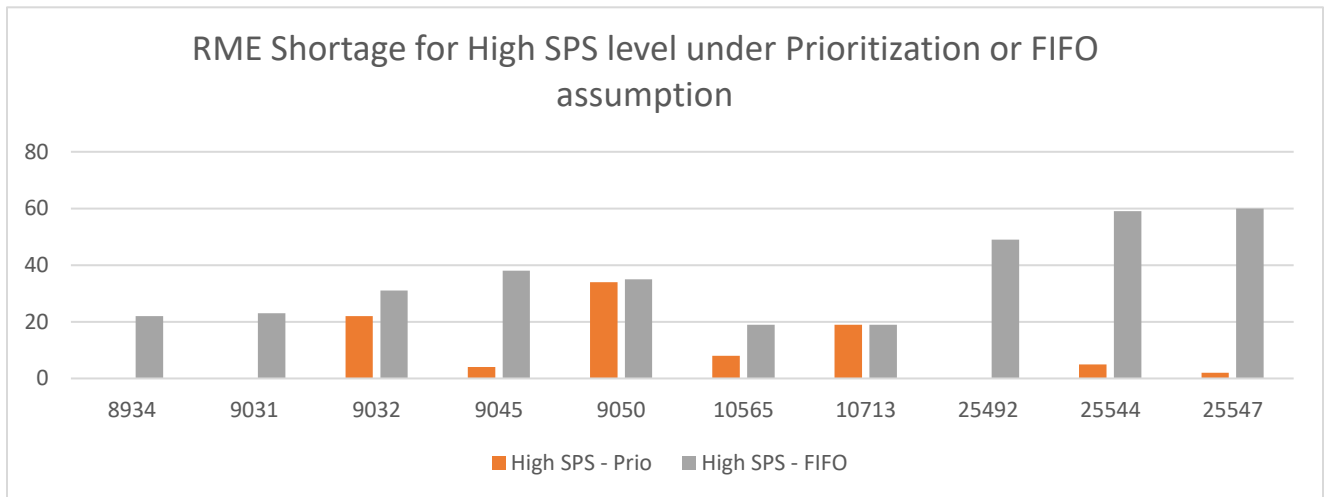

Figure 11. RME shortage for High SPS level

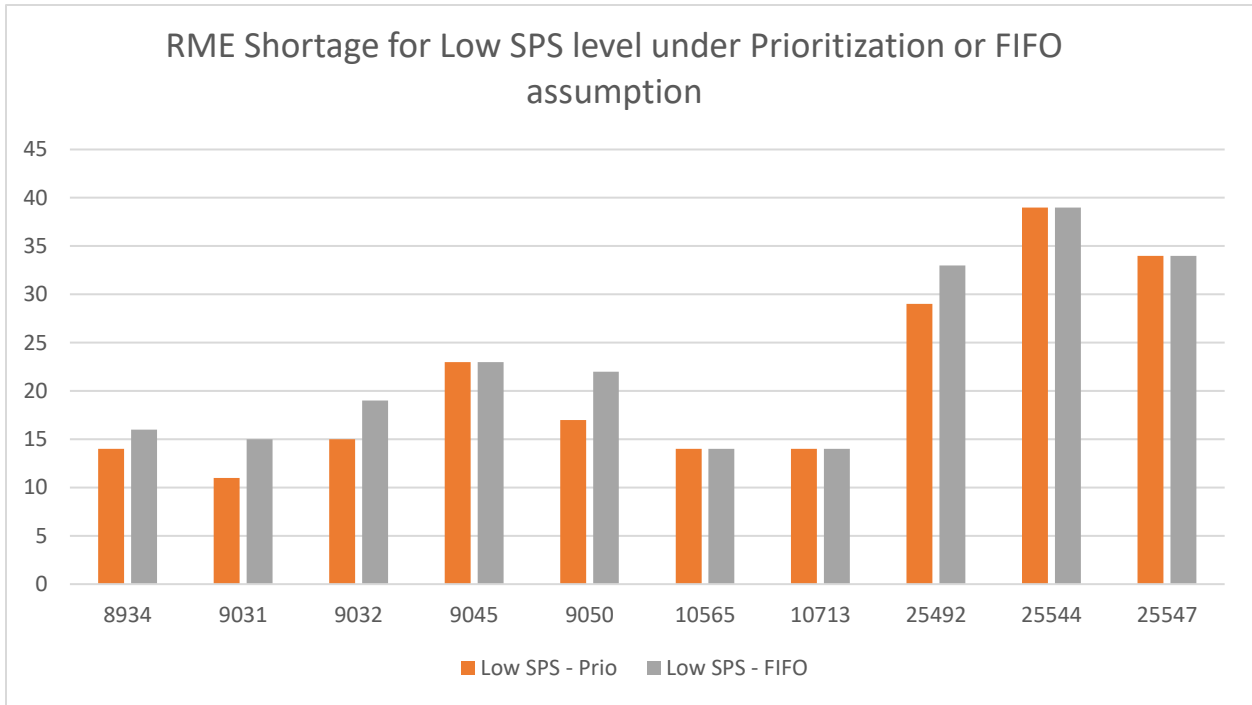

Figure 12. RME shortage for Low SPS level

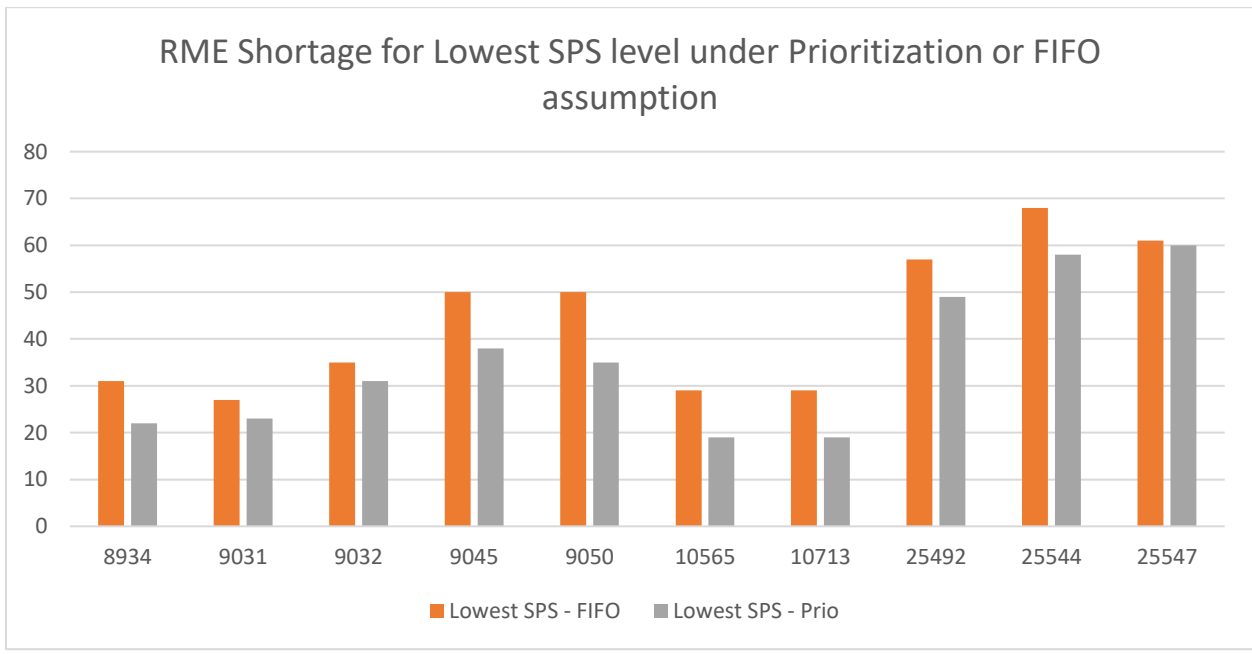

Figure 13. RME shortage for Lowest SPS level

- **Average tray shortage with original/modified inventory for Two-Day SPS Turnaround:**

After running the model with new level of inventories derived from tray utilization analysis from first step of this study, the RME shortages and case delays decreased considerably which means we can recommend the hospital to change the level of the inventory by using loaner trays to achieve high patient service level.

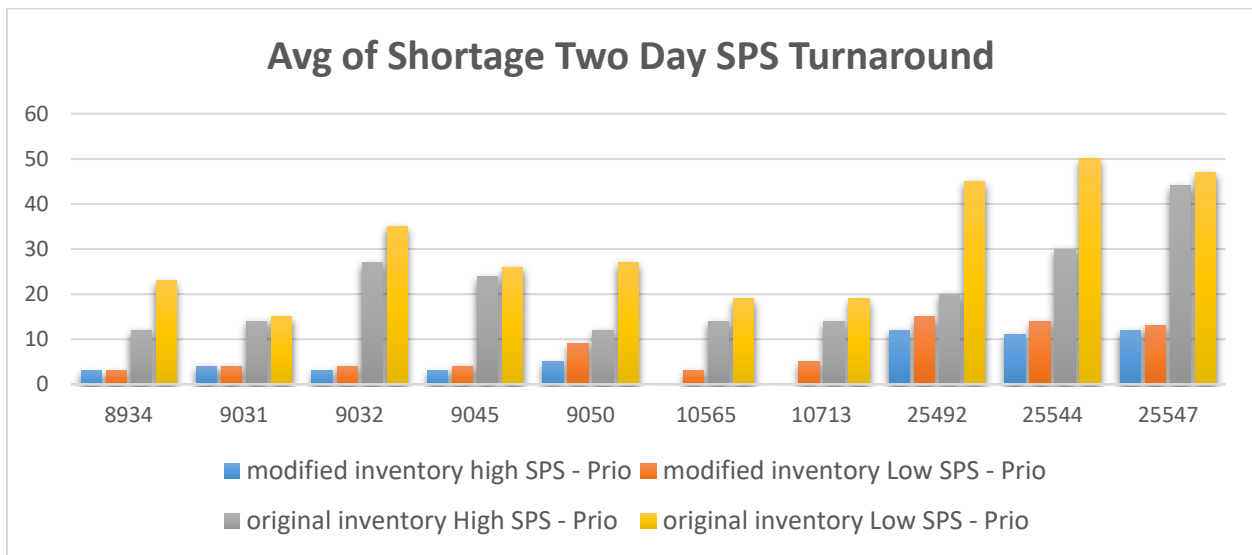

Figure 14. Avg of RME shortage with original/ modified inventory

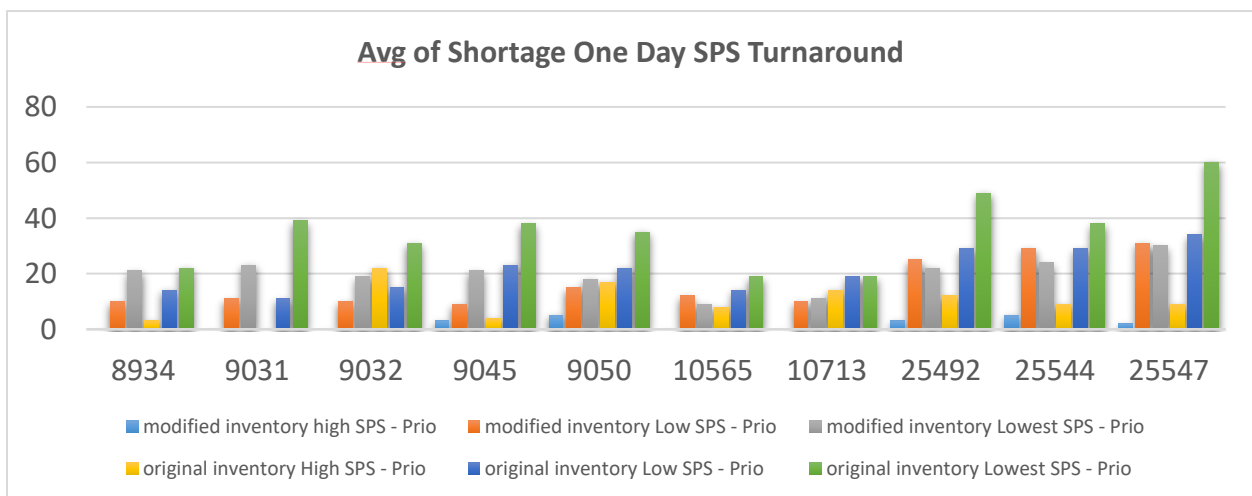

Figure 15. Avg of shortages with original and modified inventory

- **Averages of Shortages based on each criteria:**

In the figure below, average shortages of all trays based on each criteria has been calculated and depicted. From this result we recommend High level of SPS staff with customized prioritization of decontaminating the trays in SPS. Modified inventory means the inventory adjusted based on the static analysis can reduce the amount of shortages considerably.

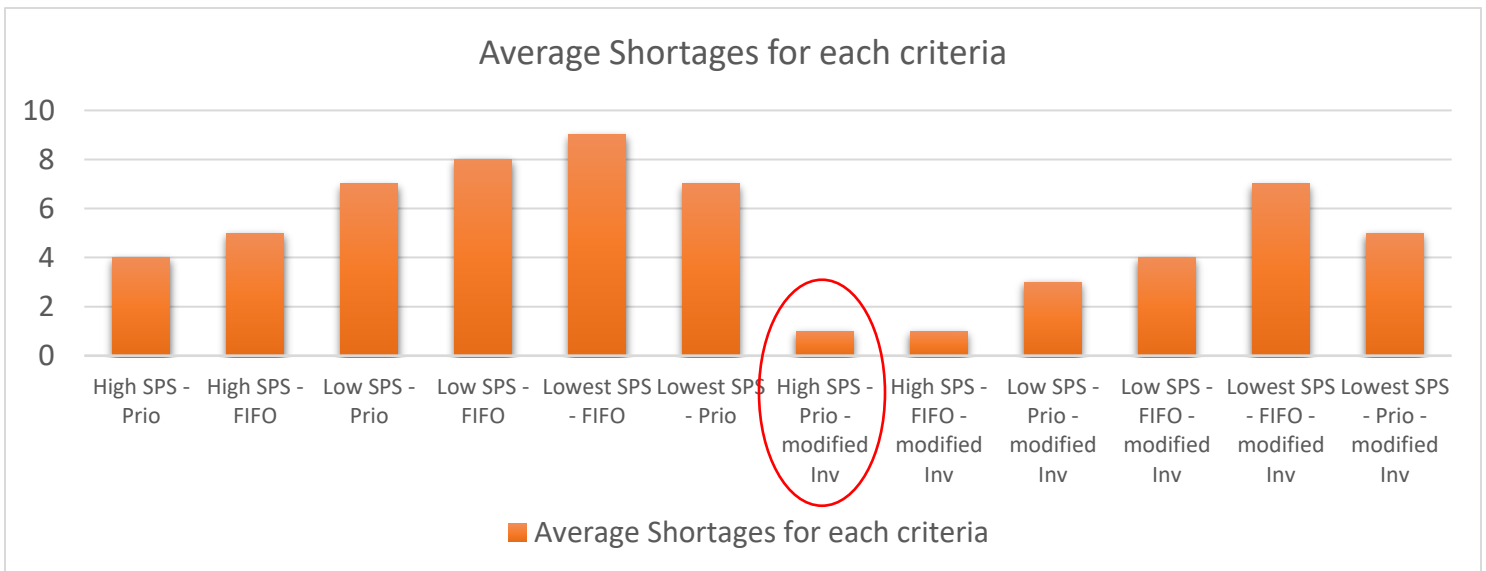

Figure 16. Avg of shortages

- **Total percentage of Delayed cases for original/ modified inventory:**

Table 3 and table 4 and two figures show how different conditions affect total percentage of delayed cases. The numbers vary from one condition to another and final decision is made based on management final goal



Two Day	% Avg Delayed Cases (Original Inventory)				% Avg Delayed Cases (Modified Inventory)			
	FIFO		Prioritization		FIFO		Prioritization	
	High SPS	Low SPS	High SPS	Low SPS	High SPS	Low SPS	High SPS	Low SPS
Sch1	31	30	30	31	10	12	7	10
Sch2	19	19	19	19	8	9	7	8
Sch3	21	21	26	26	8	8	6	8
Sch4	10	28	11	10	10	11	9	10
Sch5	40	37	15	40	15	14	12	13
Avg	24.2	27	20.2	25.2	10.2	10.8	8.2	9.8

Table 3. % Avg Delayed Cases with Original Inventory and Modified one for Two Day SPS

Also in table 4 High SPS level with Prioritization and modified inventory is more favorable in sense of higher patient service level. I have to mention that the final decision is based on management point of view whether they want to increase their service level and patient satisfactory which is profitable as well or they would rather keep same level of inventory as before. Therefore with the recommended condition the delays will decrease from 20.2% to 8.2% in two day SPS turnaround and from 27.2 to 9.2 in one day SPS turnaround.

One Day	% Avg Delayed Cases (Original Inventory)						% Avg Delayed Cases (Modified Inventory)					
	FIFO			Customized Prioritization			FIFO			Customized Prioritization		
	High SPS	Low SPS	Lowest SPS	High SPS	Low SPS	Lowest SPS	High SPS	Low SPS	Lowest SPS	High SPS	Low SPS	Lowest SPS
Sch1	30	30	30	29	30	29	10	11	23	9	10	22
Sch2	18	19	28	18	18	18	9	10	20	8	9	20
Sch3	21	23	27	20	21	20	8	9	20	7	9	19
Sch4	29	11	29	28	11	28	11	11	26	10	11	25
Sch5	40	40	41	41	38	40	13	14	31	12	12	36
Avg	27.6	24.6	31	27.2	23.6	27	10.2	11	24	9.2	10.2	24.4

Table 4. Avg Delayed Cases with Original Inventory and Modified one for One Day SPS

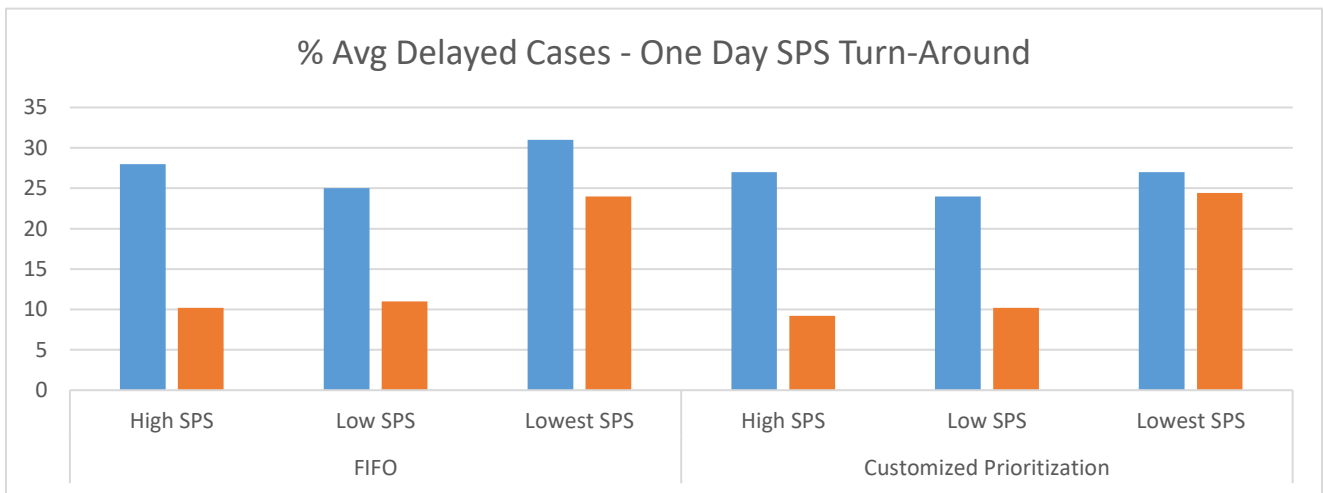
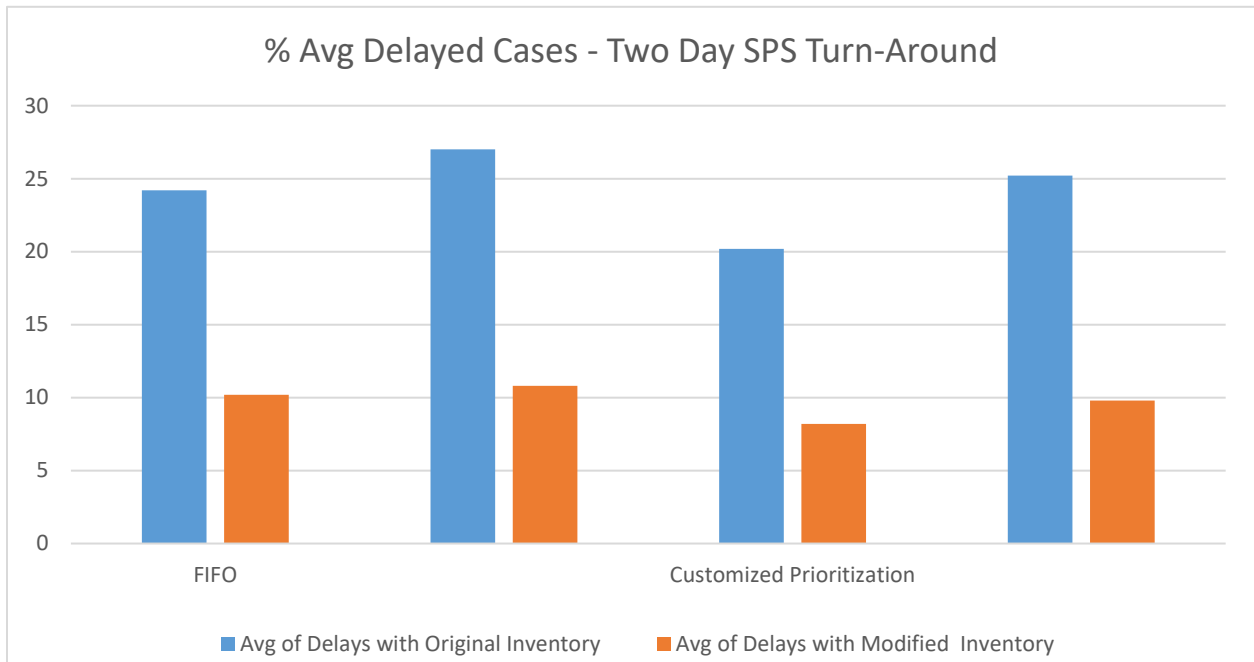

Figure 17. % Avg Delayed Cases for One day SPS



*Figure 18. %Avg Delayed Cases for two day SPS*

## Conclusion

Based on the results depicted through graphs and tables we can conclude that:

✓ **From increasing patient service level and satisfactory point of view:**

1. we recommend hospital establish high SPS staff level while sterilization department operates 24 hours 5 days of week.
2. Also they can decrease delays and shortages more by prioritizing the trays while they are in queue for decontamination process.
3. New RME inventory level can help surgery department cut the delays into less than half of the delays they faced with previous inventory level.

✓ **From cost/profit point of view:**

Managers may react to the idea of increasing level of inventory for some RME trays since if the cost of buying trays is too high it may bring zero or even negative profit for them. In this case we can recommend loaner trays and also this study is not increasing all trays inventory level. For some trays we used less than what we store in the storage. We can recommend inventory mitigation for these trays which will compensate the cost of buying RME trays for those we face shortages and delays.

## **Challenges**

- How can we make decisions over number of excess trays in the inventory when we want to make sure that they will have enough trays if an emergency will be brought up in the schedule of the same day?
- Can we conclude that the surgery cases which get the least delay time are the ones that we probably have in the inventory to the most number?
- One year historical data included so many blank data which brought difficulty to this study and the static analysis is narrowed down to complete set of data (without blanks) however for simulation purposes we tried to use data in more efficient way.

## **Future Opportunities**

There are multiple choices for further investigation with the goal of improving this research results. Firstly we can study the interplay between scheduling policies and effectiveness of the mentioned approach. Second is to develop a trend for selecting various delay reasons and debottlenecking them to improve the efficiency of the mentioned approach. [11] Also we can focus

on SPS level optimizing and change the high level SPS to a level which does not affect delays and decrease staffing costs.

# APPENDIX

## 1. Supply Processing and Distribution Functional Diagram

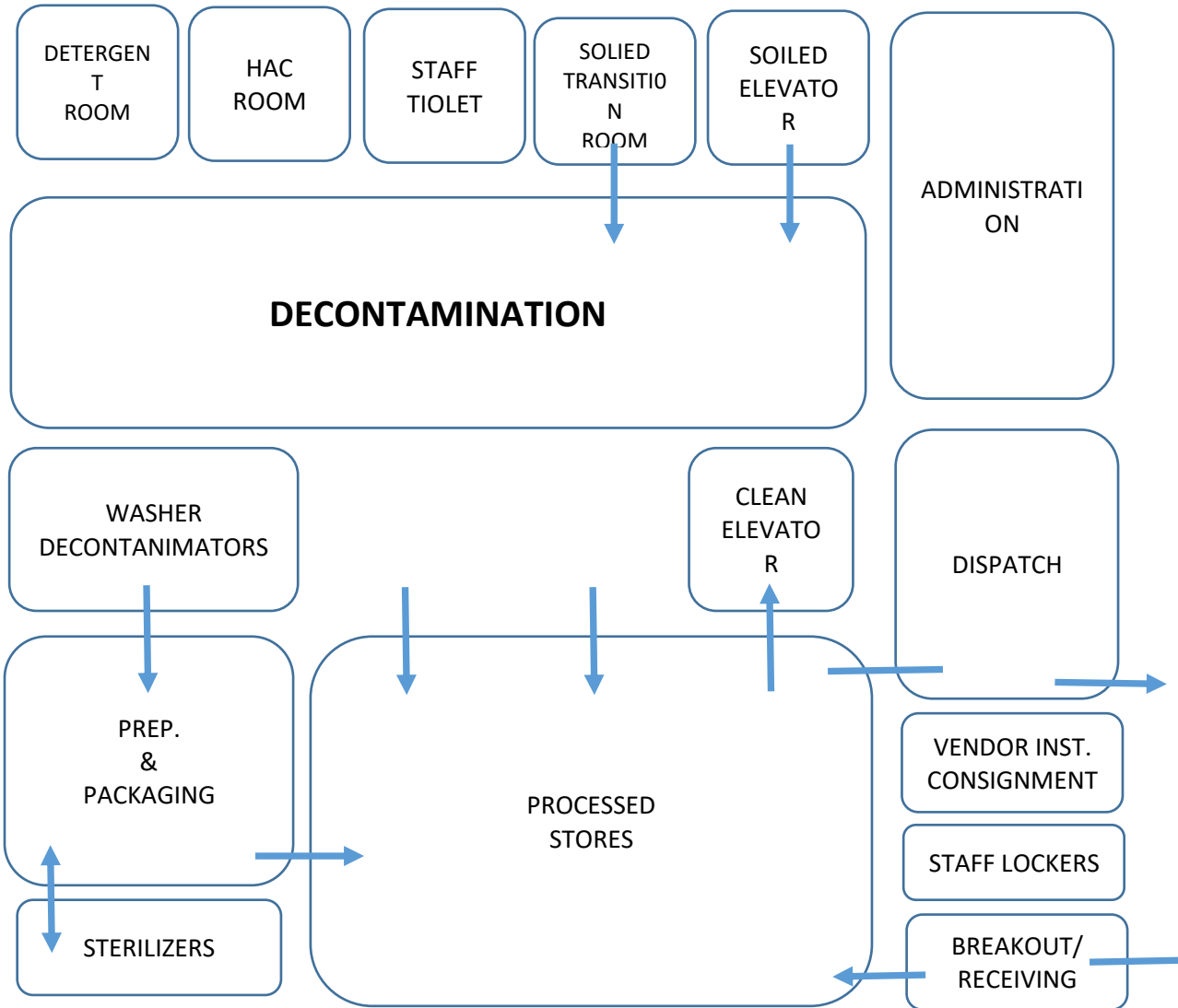

2. OR Vendor Tray Ordering Process

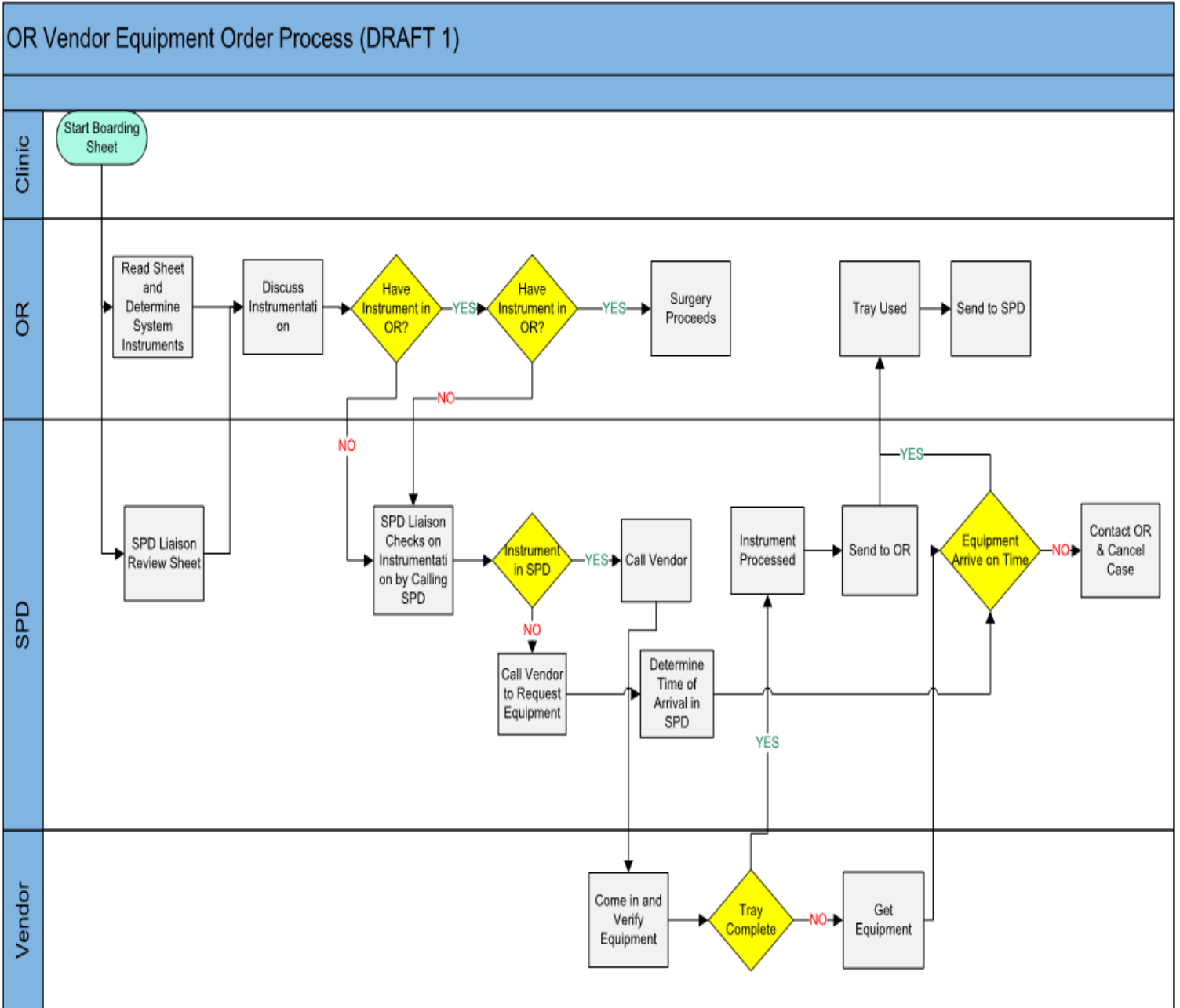

3. Tray sterilization process in detail

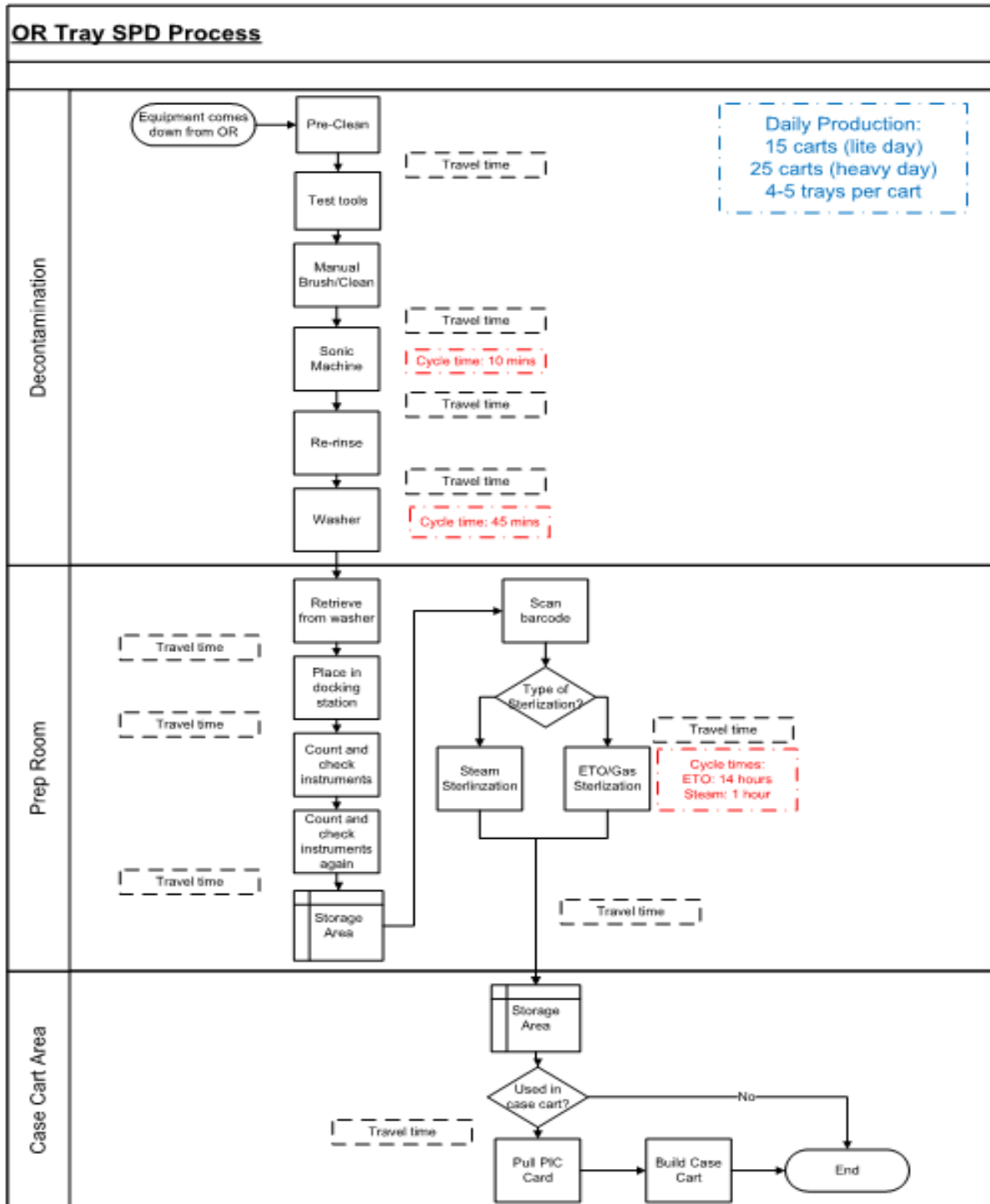



#### 4. Simulation Logic:

Start --> **BasicProcess.Create 1 (OR Demands)**

Stop --> **AdvancedProcess.Hold 9 (ORDemand)** and **AdvancedProcess.Hold 20 (Demand)**

The OR demand creates the exact entities as in the schedule. The entities are flowed in the route to get the required attributes from a read module and for each entity it's being duplicated to the number of trays the demand needs.

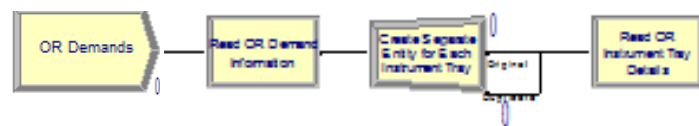

#### RME Tray Creation

Stop --> **AdvancedProcess.Hold 6 (RME Inventory)**

The above create module creates generates the total RME inventory for surgery in terms of instrument trays. The Readwrite module is for reading the instrument tray attributes in terms of quantity and type of sterilization. The assign block is used for tagging RME, OR and Podiatry identifiers. The separate module splits instrument trays into true inventory

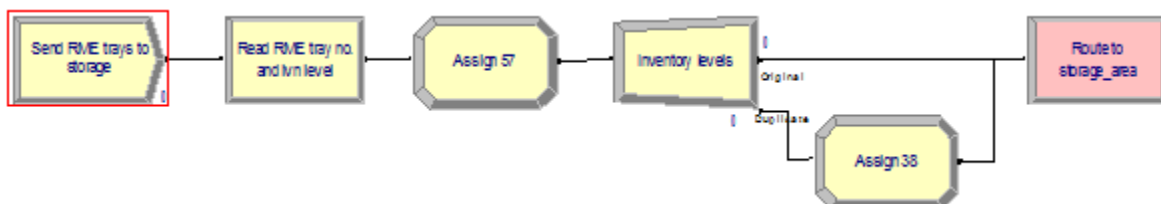

### Case Cart Creation

Start --> **BasicProcess.Create 1 (Send RME trays to inv)**

Stop --> **AdvancedProcess.Hold 7 (Cart storage)**

Generate case carts and waits for demand to fill them with specific sets of trays and send them to ORs.

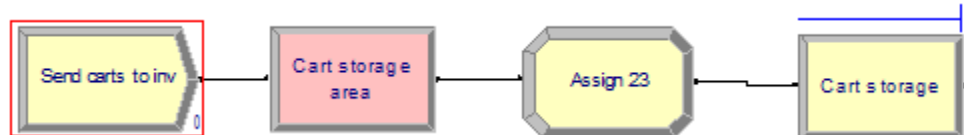

### Podiatry Clinic

Start --> **BasicProcess.Create 5 (Podiatry Patient arrival)**

Stop --> **AdvancedProcess.Hold 13 (Wait until appointment time)**

Start --> **BasicProcess.Create 6 (Podiatry RME Inventory arrival)**

Generate podiatry workload. The Readwrite module is to read podiatry. Also it creates Podiatry instrument trays and store them in its designated storage area

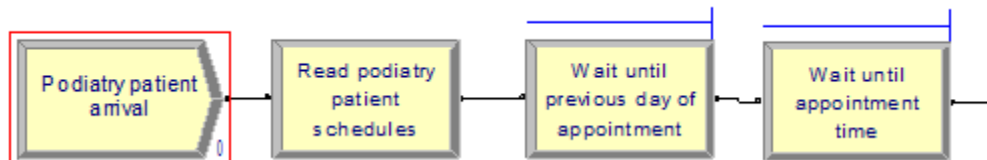

### Case Cart Search

Continue --> **BasicProcess.Assign 13 (Create Search Variables)**

Continue--> **AdvancedTransfer.Hold 9 (Operating Room)**

Create variables for checking the statuses of the required tray in the inventory. The current condition suggest that all instrument are in inventory always. Sends the RME tray to case cart preparation area and remove from inventory.

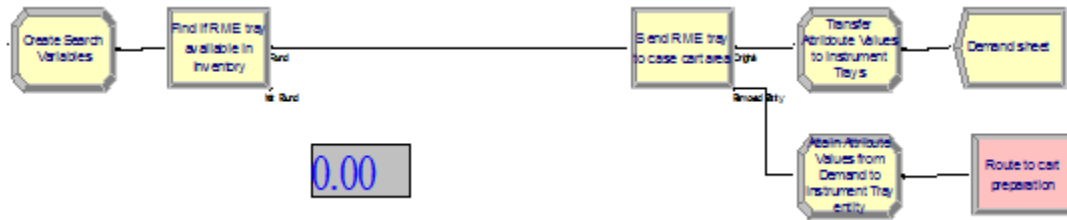

### Case-cart Preparation Area

Continue--> **AdvancedTransfer.Station 1 (Cart preparation area)**

Assemble the case carts. Assign case cart numbers and delay types. It also checks if case carts are available at the time of demand. The first decision box requires the following restriction to be checked:  $SurgeryStartTime < 23$ .

If case is delayed write the case attributes to a file and send case cart to operating room.

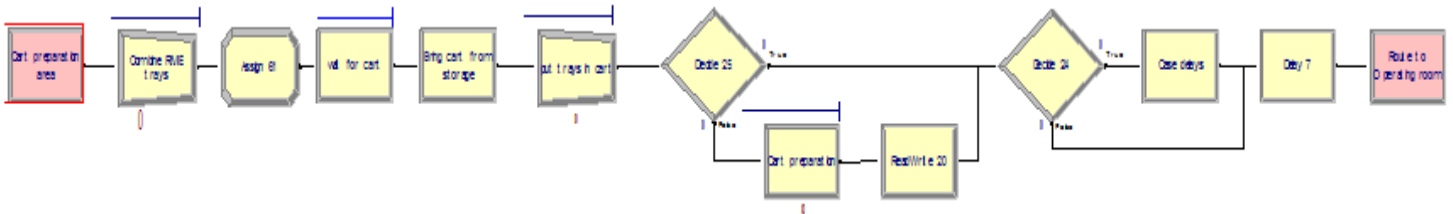

### ORs

Continue--> **AdvancedTransfer.Station 2 (Operating room area)**

The case cart and instruments stays in OR for the duration of surgery. Then they are sent to Decontamination area for the cleaning process.

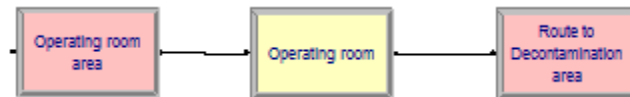

## Decontamination Area

Continue--> **AdvancedTransfer.Station 4 (Decontamination area)**

The instrument trays are separated from the case carts. The decision box routes the carts through the case cart area. The separate module splits existing batch.

We write instrument tray code and time to a file for further analysis. The decision model checks if the instrument tray is assigned to the relative scheduler. We assign specific trays to the staffs who are trained to sterilize those trays.

Then the model checks if instrument tray code is equal to the one in the search wait queue (in temp storage). If true then assign to Decont-priority queue. If false it searches of the instrument tray code in Demand queue and if it's found in demand queue, removes it from the queue.

Assign instrument tray code to an attribute and search if the instrument tray code is available in inventory queue. If it can be found in RME.inventory queue then respective attributes are being assigned. The first Readwrite module is used for reading case card attributes. The separate module is being used to generate total number of entities in terms of instrument trays. The second Readwrite is reading instrument tray attributes.

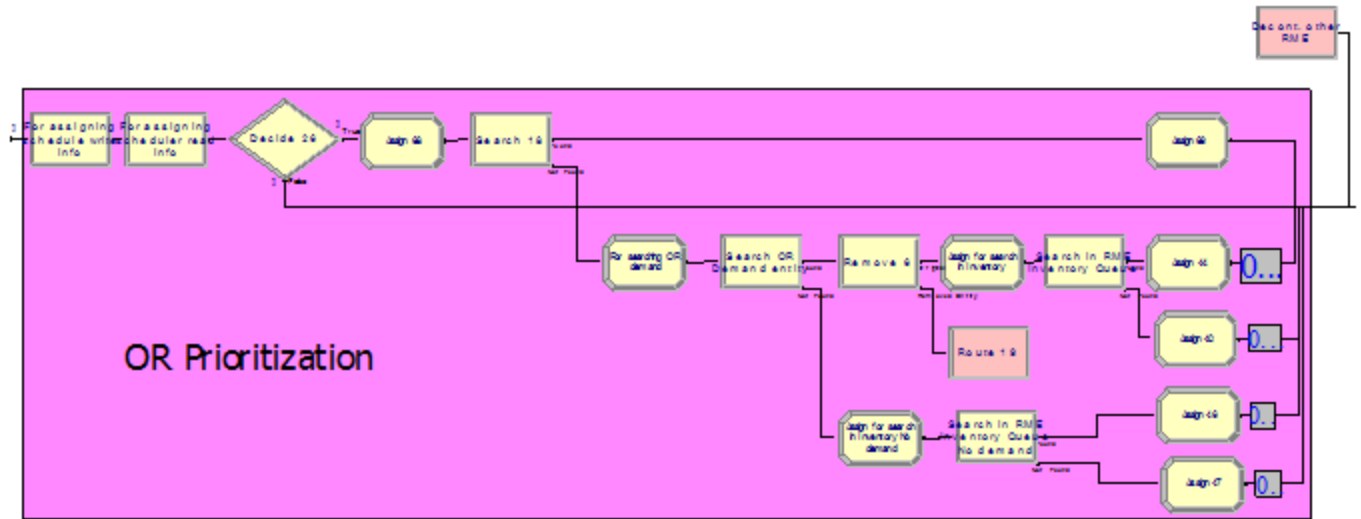
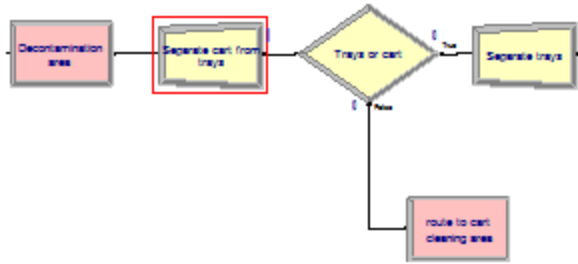

A

### Storage Area

Start --> **BasicProcess.Create 1 (Send RME trays to storage)**

The storage area stores the RME trays created previously and sends the required trays when its being called from demand part.

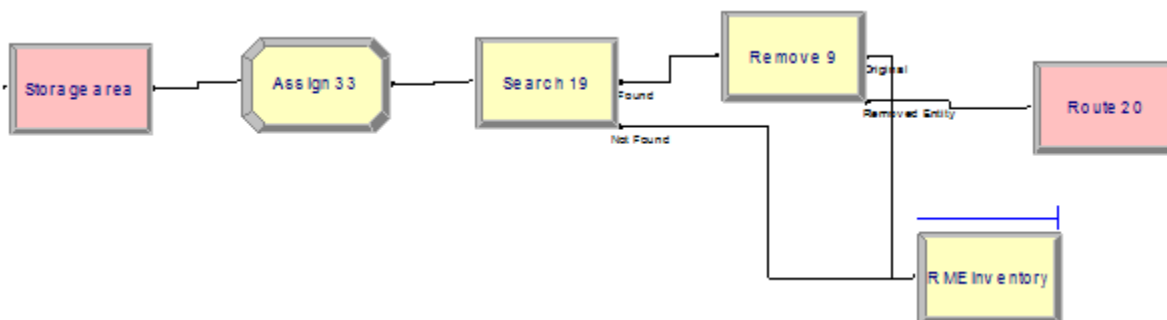

## REFERENCES

1. Saadouli, H., Jerbi, B., Dammak, A., Masmoudi, L., & Bouaziz, A. (2015). A stochastic optimization and simulation approach for scheduling operating rooms and recovery beds in an orthopedic surgery department. *Computers & Industrial Engineering*, 80, pp. 72-79. doi:10.1016/j.cie.2014.11.021
2. R. M'Hallah, A.H. Al-Room, (2014). The planning and scheduling of operating rooms: A simulation approach. Department of Statistics and Operations Research, College of Science, Kuwait University, P.O. Box 5969, Safat 13060, Kuwait.
3. Zakaria Y Abdelrasol, Nermine Harraz, Amr Eltawil. (2013). A proposed solution framework for the operating room scheduling problems. Proceedings of the World Congress on Engineering and Computer Science.
4. Surgery scheduling of multiple operating rooms under uncertainty and resource constraints of post-anesthesia care units. Proceedings of the Industrial and Systems Engineering Research Conference, Orlando, Florida, May 2012.
5. Dexter F, Wachtel RE, Epstein RH, Ledolter J, Todd MM. (2010). Analysis of operating room allocations to optimize scheduling of specialty rotations for anesthesia trainees. *Anesth Analg*. 2010 Aug;111(2):520-4. doi: 10.1213/ANE.0b013e3181e2fe5b. Epub 2010 Jun 28.
6. David M. Ferrin, Martin J. Miller, Sherry Wininger, Michael S. Neuendorf. (2004) Analyzing incentives and scheduling in a major metropolitan hospital Operating Room through simulation. Proceeding. WSC '04 Proceedings of the 36th conference on Winter simulation Pages 1975-1980 Winter Simulation Conference ©2004 ISBN:0-7803-8786-4.
7. F Dexter, A Macario, L O'Neill. Scheduling surgical cases into overflow block time - Computer simulation of the effects of scheduling strategies on operating room labor costs, *Anesthesia and Analgesia* 90: 980–988 (2000).
8. Franklin Dexter, Alex Macario, Rodney D. Traub, Margaret Hopwood, David A. Lubarsky. An operating room scheduling strategy to maximize the use of operating room block time: Computer

simulation of patient scheduling and survey of patients' preferences for surgical waiting time. *Anesthesia Analgesia*, Vol. 89 (Jul 1999) Key: citeulike:5905345.

9. Fitzpatrick, K., Baker, J. and Dave, J. (1993). An application of computer simulation to improve scheduling of hospital operating room facilities in the United States, *International Journal of Computer Application Technology* 6: 215–224.
10. Barnoon, S. and Wolfe, H. 1968. Scheduling a multiple operating room system: A simulation approach, *Health Services Research* 3: 272–285.
11. Jihan Wang, Doctor of Philosophy Dissertation, Graduate School of Wayne State University, “Operating Room Utilization and Turnover Behavioural Study”, 2012.
12. Brecht Cardoen, Erik Demeulemeester, Jeroen Belien. *Operating room planning and scheduling: List of references*. Department of Decision Sciences and Information Management, Naamsestraat 69, B-3000 Leuven, Belgium.

**ABSTRACT****REUSABLE MEDICAL EQUIPMENT INVENTORY  
ASSESSMENT AT A DETROIT MEDICAL CENTER**

by

**TANNAZ KHALEGHI****August 2015****Advisor:** Alper Murat, PhD**Major:** Industrial Engineering**Degree:** Master of Science

In recent years an outstanding growth has been observed in utilizing various medical devices due to growing demand. Hospitals, doctors, and patients are making new demands on these devices from the factory floor to the bed side, and these demands are increasing at an accelerating rate. This phenomenon can be explained through studying demand periods in which demand for the equipment has been occurred. Not only increased demand for medical equipment brings more complexity to healthcare supply chain networks but the quality is also another issue that most healthcare systems consider when they want to choose their suppliers. Apparently, when we take both quantity and quality into account, the price of medical devices becomes a critical factor to maintain cost/profit balances in financial systems. As a result healthcare systems should put stress on how many of the trays they buy and store as their inventory due to high costs. Adequate level of reusable medical equipment (RME) inventory is a crucial decision for many healthcare systems since these equipment are so expensive. On the other hand they can't sacrifices RME availability for vital departments such as surgery, emergency, and ICU/PACU to decrease the inventory level



and correspondingly ordering and holding costs. Healthcare systems critical responsibility in sense of immediate reactions in health-related issues of patients brighten this fact that shortage of RME is not acceptable at all. In order to avoid this issue, in this study we brought some historical data from past year surgery schedules and their potential RME inventory count. First we deploy an inventory management method to perform brief analysis on data of RME inventory to check both the current utilization levels of RME inventory and minimum level of RME inventory, demanded daily by surgical department in the hospital, by a heuristic approach for adjusting inventory counts of RME trays. This analysis is performed under two assumptions as is so-called one-day and two-day SPS turnaround. The RME tray inventory level can be adjusted in this stage and further will be used to run the simulation with modified inventory to precisely locate the delays and shortages. We use discrete event simulation model with multi functions, one with SPS RME sequencing by prioritization of the trays and the other one with FIFO system for sequencing RME trays in sterilization department. By running both models we aim to get the required outputs and analyze RME sterilization process influence on delays and number of trays shortages.

Keywords: RME trays, Discrete Event Simulation, Cycle Service Level, Operating Room, SPS Turnaround Time, SPS Prioritization.

## **AUTOBIOGRAPHICAL STATEMENT**

I am Tannaz Khaleghi and I began ISE program in 2013 to pursue my master degree at Wayne State University. I also have received my Bachelor's degree from Shahid Bahonar University in winter 2013. During my first semester of my master studies I've got a chance to get involved in a research project, working on simulation models in order to visualize the behavior of the system and predict the bottlenecks in the system. I worked in an active and professional team and gained new knowledge and experience. I contributed to this graduate level program through my research, coordination and energy while increasing the intellectual richness and diversity of the university throughout two years of my master studies. Therefore, when setting my next academic goal on the way, the PhD level, for serving people in the best way I tried to master this field theoretically as well as developing my skills in handling real world projects by learning different modern tools and strategies. I am so grateful that I have received lots of support and motivation to reach to the point where I am today.