



Title	The ISD process as a 'live routine'
Author(s)	Sammon, David; Nagle, Tadhg; McAvoy, John
Editor(s)	Castelnovo, Walter Ferrar, Elena
Publication date	2011-09
Original citation	Sammon, D., Nagle, T., and McAvoy, J. (2011) 'The ISD Process as a 'Live Routine'' in Castelnovo, W. and Ferrar, E. (eds.) ECIME 2011: 5th European Conference on Information Management and Evaluation, Como, Italy, 8-9 September, ACPIL proceedings, Reading: Academic Conferences International Limited, pp. 428-435. isbn: 978-1-908272-12-6
Type of publication	Book chapter Conference item
Link to publisher's version	http://www.academic-bookshop.com/ourshop/prod_1578724-ECIME-2011-5th-European-Conference-on-Information-Management-and-Evaluation-Como-Italy-PRINT-version.html Access to the full text of the published version may require a subscription.
Rights	© 2011 the authors; Academic Conferences and Publishing International Limited, ACPIL proceedings
Item downloaded from	http://hdl.handle.net/10468/5182

Downloaded on 2018-08-23T20:20:56Z

The ISD Process as a Live Routine

David Sammon, Tadhg Nagle and John McAvoy
University College Cork, Ireland

dsammon@afis.ucc.ie

t.nagle@ucc.ie

j.mcavoy@ucc.ie

Abstract: The objective of this exploratory study is to view an ISD process as an organisational routine in an effort to identify the inefficiencies in the process. To meet this objective we present the findings from a sixteen month case study of an ISD organisation, examining the ISD process the starting point of which is the *requirements elicitation* (RE) phase. A variety of data gathering techniques are used across two phases of data collection. The case data is organised as a narrative network (NN) of the organisational routine (ISD process) allowing us to understand the ISD process as a collection of functional events/narrative fragments, generated by the enactment of the organisational routine. The NN is showing itself to be a very powerful device to appreciate the knock-on impacts of vague and incomplete requirements (poor *requirements elicitation*) on downstream ISD process '*patterns of action*'. In the findings of this research we generate an '*ostensive*' rule that defines a valid sequence of action in the ISD process. As a case study, the methods and results provide a means of comparison to additional cases of ISD organisations.

Keywords: routines, Information Systems Development (ISD), narrative network, case study

1. Introduction

Information Systems Development (ISD) organisations are faced with increasing demands to deliver high quality information systems more efficiently. However, irrespective of the strategies or methodologies adopted to organise an organisation's ISD process, *requirements elicitation* (RE) still remains a critical phase, having significant impacts on software quality and costs (c.f. Chakraborty *et al.*, 2010). In fact, it is widely reported that incomplete and inaccurate user requirements collection, during a RE phase, can lead to failed ISD projects (Mathiassen *et al.*, 2007, Chakraborty *et al.*, 2010) (Byrd *et al.*, 1992).

Invariably, organisations are continually looking to improve the process of [1] gathering and documenting user requirements, and [2] developing solutions around what the customer wants. However, while there is a substantial body of knowledge around RE, enumerating factors, tools, and techniques focused on creating an effective RE process (c.f. Benbasat *et al.*, 1987, Byrd *et al.*, 1992, Mathiassen *et al.*, 2007, Chakraborty *et al.*, 2010); the intricacies of the process of RE have been under researched. Furthermore, as argued by (Chakraborty *et al.*, 2010) there are very few studies examining how the social process associated with RE unfolds. However, ISD has been viewed as a 'social process rather than a merely technical one' (Hansen and Rennecker, 2010), p.450 enacted by various development team members (human actors) (e.g. project managers (PM), business analysts (BA), developers, testers, etc.). In an effort to address this paucity of research around viewing RE as a social process, we propose that the ISD process should be viewed as an 'organisational routine' (c.f. Pentland and Feldman, 2008), the first phase of which is RE. Therefore, the objective of this exploratory research study is to view an ISD process as an organisational routine in an effort to identify the inefficiencies in the ISD process.

The remainder of this paper is organised as follows. The next section describes organisational routines and the use of a narrative network (NN) to represent '*live routines*'. This is followed by a description of the research design. The case analysis is then presented where the ISD process is visualised as a NN and four '*patterns of action*' are highlighted (reflecting the inefficiencies in the ISD process). The paper concludes with a rule to address the ISD process inefficiencies.

2. Organisational routines

Organisational routines are a foundation for understanding business processes and are defined as repetitive and recognisable '*patterns of action*' carried out by multiple actors (Pentland and Feldman, 2007; 2008). The theory of organisational routines emphasises the participation of multiple actors (human and non-human) and '*this is what distinguishes a routine as organisational rather than individual*' (Pentland and Feldman, 2007p. 787). Indeed, if organisational routines are viewed as a '*generative system*', multiple human actors suggests multiplicity of perspective and understanding; therefore, different actions may be taken and different actors may be used (e.g. non-human –

computer-based artefacts) at various points in accomplishing the same routine (Pentland and Feldman, 2007; 2008). This view of organisational routines promotes the concept of *'live routines'* over *'dead routines'*, where *'live routines'* involve people, who are capable of *'learning from experience'* and *'dead routines'* are artefacts that are *'rigid, mundane, mindless'*, and can be explicitly stored (c.f. Pentland and Feldman, 2008). Therefore, *'live routines'* are not fixed patterns; they are *'generative systems'* that can produce *'patterns of action'* based on local judgement and improvisation by actors.

Any social system that satisfies the definition of an organisational routine must consist of two complementary aspects: the *'ostensive'* and the *'performative'* (Pentland and Feldman, 2007; 2008). While the *'ostensive'* aspect consists of the abstract, generalised understandings of the human actors regarding enacting a routine (*a model of*) and the steps involved in accomplishing the task (*a model for*), the *'performative'* aspect consists of the concrete, specific performances/enactment of the routine (Pentland and Feldman, 2007). However, in the realities of an organisational environment, while *"performances are often filled with improvisations – adjustments and variations that make it possible to get things done in diverse situations"* (Pentland and Feldman, 2007, p.787) there is a need for an effective representation of the *'patterns of action'* that define the *'performances'* of organisational routines.

Within the context of this research study viewing the ISD process as an organisational routine has significant value, for example, irrespective of the methodology adopted for ISD there will always be an associated recognisable pattern of repetitive actions (e.g. requirements gathering, coding, testing) to be carried out by multiple actors (e.g. business analyst, developer, tester). However, while the *'ostensive'* aspects of the organisational routine may be captured in the design of the organisational artefact (e.g. the adopted ISD methodology), and while this may constrain the performances in some desirable way, it is the actual performances (*'performative'* aspects) inherent in the execution of the ISD process that are of most interest in an effort to understand how the routine actually *lives* in the organisational environment.

2.1 A narrative network of an organisational routine

A narrative network (NN) is a new methodological device that provides 'an explicit representation of an organisational routine as a pattern of action' and provides 'a way to describe patterns of action, as well as the actions' (Pentland and Feldman, 2008, p.244). The NN is an appropriate conceptual tool when examining 'live routines', where it is expected that different 'patterns of action' will emerge over time, therefore, the NN ensures a dynamic and longitudinal focus on organisational practices (c.f. Yeow and Faraj, 2011; Pentland and Feldman, 2008). The NN is founded on key principles emerging from a synthesis of research on: structuration theory, actor-network theory, and organisational routines (c.f. Yeow and Faraj, 2011; Pentland and Feldman, 2008).

The NN is defined as "a collection of functional events related by their sequential occurrence in a story or set of stories" (Pentland and Feldman, 2008, p.244). Therefore, the "functional event is the building block of a narrative; it is a fragment that advances the story" (Pentland and Feldman, 2008, p.244). A functional event is similar to the structure of a simple sentence, two actors (human and non-human) connected by some action, 'subject-verb-object' and uncovers 'important information about who does what' (Pentland and Feldman, 2008, p.244). In the context of this research study, typical functional events for an ISD process include: a customer requests a system, a business analyst gathers customer requirements, a developer writes code, and a tester evaluates the system. Therefore, the NN perspective represents the functional events (narrative fragments) of an organisational routine as 'nodes' in the network and the sequence of functional events as 'ties' in the network (c.f. Yeow and Faraj, 2011; Pentland and Feldman, 2008). As a result, the NN perspective facilitates the explicit 'capture of actors, artefacts and actions as well as the process by which work is currently or potentially done' (Yeow and Faraj, 2011). The NN perspective facilitates the examination of actual 'patterns of action' that emerge from the living routines and not just a limited view of expected/idealised patterns reflected in a process design (Pentland and Feldman, 2008). Furthermore, the NN perspective facilitates focusing on the tasks that actors engage in when enacting a 'live routine' in all its variations, as opposed to just simply focusing on one version of the process and its decision points, as provided by process flowcharts (Yeow and Faraj, 2011).

In the research design section we provide a commentary on how to construct the NN of the ISD process. Using a NN perspective to analyse an organisation's ISD process, and the associated

internal interactions between the multiple human actors, will provide new insights through viewing the ISD process as a 'live routine'. In the next section we now present the case study research design.

3. Research design

In the context of this research study, a '*freshness in perspective*' (c.f. Eisenhardt, 1989 p.548) is required on the topic despite the fact that the ISD process and the associated methodologies themselves have received considerable attention in past research. Therefore, in light of the lack of theoretical maturity around the viewing an ISD process as an organisational routine, this exploratory research sought to build theory using a single instrumental case study design. While an '*instrumental case study*' research strategy was adopted for this study, it allowed the researchers to pursue a deep understanding of an issue as a primary focus, while the '*case itself was of secondary interest*' (Stake, 2000). Therefore, to fulfil the objective of this research, studying a single instrumental case facilitated uncovering and teasing out the diverse organisational stories of those '*living the case*' (Stake, 2000). See Table 1 for a detailed outline of the case study research protocol.

3.1 Case study

The objective of this exploratory study is to view an ISD process as an organisational routine in an effort to identify the inefficiencies in the ISD process. Considering the ISD process as an organisational routine, organised as a NN, will provide a fresh perspective to understanding an organisation's ISD lifecycle. For this exploratory case study research, the organisation is referred to as DevCo. DevCo has established itself on the global market as a trusted service provider of web-based data management applications, serving a range of government, healthcare and private sector organisations. Coupling geographical location with specific segments of the ISD lifecycle, the organisations structure is defined as follows: (i) London (UK) – incorporates business analysis, project management and business development, (ii) Cork (Ireland) – incorporates call centre operations, after sales service and first line support, (iii) Moscow (Russia) - incorporates software development, technology infrastructure maintenance and software testing.

DevCo values long term relationships with its clients, to meet and exceed their evolving expectations, which is evident in the long term contracts they hold with their clients. From a process perspective DevCo demonstrate continuing commitment to developing its software products to the highest quality standards (e.g. e-GIF (UK e-Government Interoperability Framework) standards of best practice, Royal National Institute of Blind People (RNIB) (See it Right standard) and W3C-WAI (up to AAA) usability standards). Furthermore, DevCo offices are certified to the ISO 27001 standard for information management and security by the British Standards Institute (BSI), ensuring that all information handled conforms to best practices in a highly secure and audited data management environment.

Emerging from a strong organisational necessity, the research objective was in line with the CEO's requirement for an external analysis of DevCo's ISD lifecycle and his belief that it could be more efficient. As a result, this was the point of departure for the three person research team from which the case study research protocol was developed (see Table1).

Table 1: Case study research protocol (after: (Kelliher, 2005))

Research Activity	Description
Objective	To identify the inefficiencies in an ISD process
Approach	Case Study (October 2009 – January 2011)
Motivation	CEO's interest in achieving ISD process efficiencies.
Case Selection Process	A software development organisation where the CEO sought improvements in the ways of working
Case Access	A unique openness to share information and a willingness to make personnel available for the research, to the extent that operations were suspended for three days to enable workshops to be carried out
Instrument	The research team (three researchers) were the primary research instruments in the application of the data gathering techniques
Boundary Device	ISD lifecycle, the first phase of which is <i>requirements elicitation</i> (RE)
Data Gathering Techniques	On-site observations by research team; Semi-structured interviews; Round table discussions; Intensive on-site workshops with global project team participants
Data Organisation & Analysis Techniques	The NN perspective was used to organise the case data and facilitate the data reduction and analysis process to build a logical chain of evidence for the case.

3.2 Data gathering, organisation and analysis

The sixteen month exploratory research project was broken into two phases for the purposes of data gathering. The data gathering was conducted over a seven month period (October-April) using a variety of techniques, as presented in Table 1. Table 2 now presents that data gathering conducted in chronological order. In total, 25 hours of interview data recorded, and 24 hours of workshop data recorded across the three workshops.

Table 2: Chronology of data gathering

Phase/Date	Technique	Focus
1/October-December	Interviewing / Round Table Discussion	Preliminary group-based interviews/discussions on organisational requirements
2/March-April	On-Site Workshop	workshops with participants organised around ISD process for core organisational projects
2/March-April	Interviewing / Observation	Interviews with BAs/PMs/developers around assessment of communication tool effectiveness within ISD process

Phase 1 data gathering involved preliminary group based interviews and discussions that provided a detailed background description of the organisation and its ISD process at a high level. Following on, Phase 2 of the research strategy set out to provide qualitative richness and to develop a deeper understanding of the organisation's ISD process. In particular, after phase 1, themes were identified from the preliminary group-based interviews/discussions and areas of interest were highlighted. This provided the research team with the opportunity to focus their attentions for phase 2 data gathering. It was important that phase 2 data gathering was effective as the organisation made a significant commitment to the research both financially and in terms of disruption to operations during the three workshops. Two of the workshops took place in Moscow (Russia) and employees from the London (UK) and Cork (Ireland) offices were also made available for participation over a three day period. The third workshop took place in Cork (Ireland) and several London (UK) employees were also made available for participation.

Furthermore, phase 2 data gathering workshops were organised around the projects which defined the fabric of the ISD organisation to date. For the most part these projects are revenue generating for external customers (predominantly long-term public sector contracts), with a growing number of internal customer projects initiated in more recent years – to introduce efficiencies through technology enhanced processing. Workshop participants were challenged on aspects of *requirements elicitation* (RE), development, test and release activities currently undertaken by various organisational actors as part of the existing ISD process execution. Also, due to the globally distributed nature of the organisation, attention was focused on the effectiveness of the communication tools used (specifically by business analysts/project managers and developers in the absence of face-to-face communication) in support of various activities in the ISD process.

Analysing the data collected in phase 2, the case data is organised as a narrative network (NN) of the organisational routine, which provides an insight into the *'patterns of action'* (c.f. Pentland and Feldman, 2008) that define the ISD process. The steps associated with constructing a NN are now presented in Table 3.

Table 3: Construction of a narrative network (after: Pentland and Feldman, 2008)

Step	Description	This Research Study
1. define boundary of focal phenomenon	The NN is defined by a generic storyline that defines some sphere of activity. Organisational research uses <i>purpose</i> as an important part of a boundary.	ISD process
2. choose a point of view	Fieldwork data will contain data from someone's point of view, so we never know the whole story. The researcher can pick a single point of view or aggregate several different ones.	Aggregate of views from BAs/PMs, developers, testers
3. collect narratives and code the fragments	Gather data using methods that seem appropriate to ensure that narrative fragments are complete and that the researcher can uncover the connections that informants are making	Face-to-Face Interviews; Intensive Workshops; Observation
4. relate codes by sequence	Narrative fragments need to be related in ordered sequence – a <i>'what happens next?'</i>	All events were connected in sequence

4. Case analysis

In this section, for the purposes of clarity, we present one aggregated ‘performance’ (c.f. Pentland and Feldman, 2008) of the functional events associated with the organisational routine (ISD process). It is worth noting that for the purposes of this paper, we are documenting what can be considered the ‘worst-case scenario’ within the ISD process. It is not to say that these ‘patterns of action’ always occur within DevCo but they do at times define the fabric of the organisation’s approach to the ISD process and by the organisation’s own admission are unacceptable and need to be changed. The NN is now presented in the next section.

4.1 A narrative network of the ISD process

For the purposes of this paper we are interested in representing the ‘patterns of action’ of the DevCo personnel for the requirements elicitation (RE) and development efforts only. Therefore, we have excluded representing ISD testing for simplicity. The NN is illustrated in Figure 1, while Table 4 contains a list of the functional events/narrative fragments associated with the ISD process.

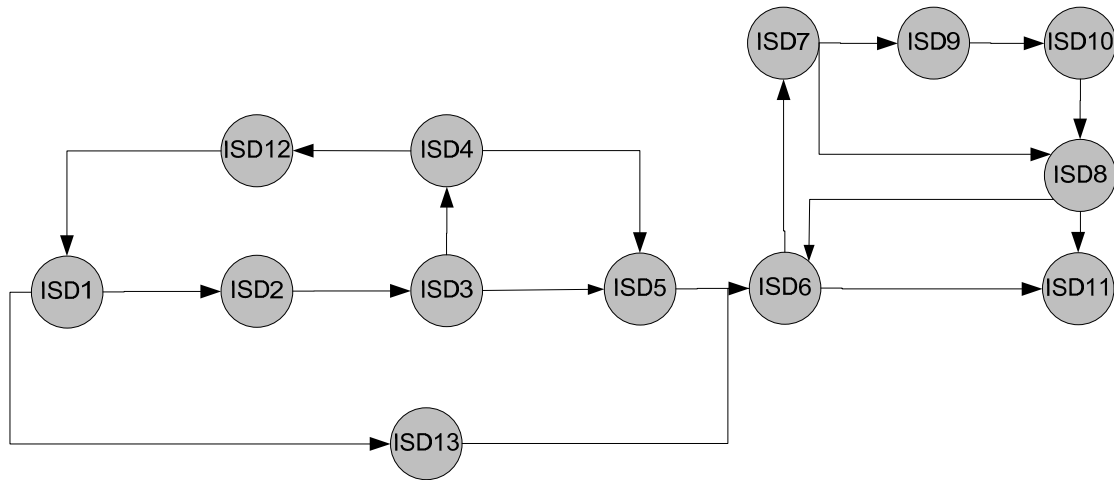

Figure 1: Narrative network of the ISD process

Table 4: Functional events (narrative fragments) of the ISD process

NN Label	Functional Event/Narrative Fragment
ISD1	BAs/PMs gather customer requirements
ISD2	BAs/PMs create tickets (requirements) with a ‘pending status’ on in-house ticketing system
ISD3	Lead developers spend time cleaning the specification (tickets) with BAs/PMs
ISD4	Lead developers flag incomplete requirements with ‘in discussion’ status on in-house ticketing system
ISD5	Lead developers assign tickets to developers
ISD6	Developers conduct technical research on requirements
ISD7	Developers seek clarification on tickets (requirements) from lead developers
ISD8	Lead developers clarify issues for developers
ISD9	Lead developers seek clarification of issues from BAs/PMs
ISD10	BAs/PMs clarify issues for lead developers
ISD11	Developers write code based on requirements
ISD12	Developers email BAs/PMs about ‘in discussion’ status tickets
ISD13	BAs/PMs send requirements clarifications by email to developers

As can be seen in Figure 1, the ISD process (organisational routine) begins with the BAs/PMs in the London office gathering the customer requirements (ISD1) and structuring the ISD project requirements as a set of tickets on the in-house ticketing system (ISD2). The lead developers in the Moscow office then clean the requirements specification with the BAs/PMs (ISD3) and categorise

some of the tickets, that have incomplete/vague requirements, with an 'in discussion' status (ISD4). At this point the lead developers assign the 'high priority' fully specified requirements to developers (ISD5). The developers then undertake research on the technical aspects required to fulfil each requirement (ISD6) and in 100% of all requirements the developers seek some form of simple/complex clarification for the lead developers (ISD7). Depending on the nature of the clarification being sought, lead developers either provide the information to the developers directly (ISD8) at which time the developers then write code based on the requirement (ISD11), or the lead developers seek clarification on the issues from the BAs in the London office (ISD9). When the BAs/PMs provide clarification on the issues (ISD10), the lead developers pass the information onto the developers (ISD8), at which time the developers either commence writing code (ISD11) or undertake technical research (ISD6) before coding the requirement (ISD11).

As time progresses through the release of the project (a release usually lasting 3 months on average for most projects) some of the 'in discussion' status tickets remain incomplete and the developers email the BAs/PMs for clarification on these requirements (ISD12) in an effort to complete the release on time. This necessitates the BAs/PMs to urgently gather requirements from the customer (ISD1) and once the required information is gathered the BAs/PMs send the updates by email to the developers (ISD13) to complete the release. On receipt of this requirements clarification information, the developers undertake further technical research (ISD6) before coding the requirement (ISD11).

4.2 The ISD process inefficiencies as 'patterns of action'

Based on the storytelling of the organisational actors (PMs/BAs/lead developers/developers) and appreciating the narrative fragments generated from their representation of the ISD process (see Figure 1), four defining 'patterns of action' emerged which represented a macro perspective on the functional events of the ISD process. The four 'patterns of action' were referred to as: *BA/PM Helplessness*, *Awaiting Communication*, *Buffer Time Erosion*, and *Pressure Cooker Development* by DevCo personnel. Table 5 provides detail of the narrative fragments from Table 4 associated with each of the four 'patterns of action'.

Table 5: ISD process 'patterns of action'

Functional Event/Narrative Fragment	Pattern of Action
ISD1 → ISD2 → ISD3 → ISD4	BA/PM Helplessness
ISD4 → ISD12 / ISD7 → ISD8 / ISD7 → ISD9 → ISD10	Awaiting Communication
ISD12 → ISD1 → ISD13	Buffer Time Erosion
ISD13 → ISD6 → ISD11	Pressure Cooker Development

4.2.1 'BA/PM helplessness' pattern of action

Within DevCo the BAs and PMs, based in the London office, are the first points of contact with their customers. Therefore, the BAs/PMs are responsible for gathering the system requirements from these end-users; however, managing these customers is a problem for the BAs/PMs and as one PM described the situation "we often feel helpless when determining the requirements of the customer". Based on our analysis it is obvious that this sense of helplessness comes from the customers' lack of appreciation of the immediate nature of *requirements elicitation* (RE) as part of an efficient ISD process. However, this lack of immediacy is linked to the organisation's willingness to accommodate the customer and the nature of the customer themselves. While this willingness is a unique selling point for DevCo, in the market for attracting and retaining business, it is the root cause of inefficiencies to their internal downstream ISD processes, due to the fact that the RE process cannot be completed in an expeditious fashion and with the required completeness of information.

As can be seen from the narrative fragments in Table 5, the defining characteristic of the '*BA/PM Helplessness*' pattern of action, worryingly, is the fact that the RE process ends up with high priority requirements 'in discussion' due to incompleteness (ISD4). Therefore, DevCo often find that they are commencing the development of the customer solution with incomplete, vague and in some cases missing system requirements; where some of the missing requirements are identified later in the ISD process as being extremely critical to the functionality of the system overall. These incomplete, vague and missing requirements create what is referred to as the '*Awaiting Communication*' pattern of action.

4.2.2 'Awaiting communication' pattern of action

Three differing 'Awaiting Communication' patterns of action are observed within the DevCo ISD process, caused directly by the ineffective RE process (see Table 5). Two of the patterns of action (ISD7 → ISD8 / ISD7 → ISD9 → ISD10) causing inefficiency relate directly to the way in which customer requirements are communicated to the developers, by the BA/PM, using their in-house ticketing system. It emerged during the case that BAs/PMs document requirements by going into a level of overcomplicated technical detail that is not required by the developers. As suggested by one of the developers "we want to know what to do, not how to do it, therefore, the BA should better define the problem, not the solution". In one extreme case an example was made of a requirements ticket where four to five years of data history was captured but contained 'zero useful information for the developers'. This scenario has led to a situation where developers seek clarification, within their office or externally from the BA/PM, on 100% of requirements captured on the ticketing system for a project release. This excess clarification is a waste of time for both developers and BAs/PMs themselves and links directly to the ineffective representation of the customer requirements by the BA/PM in the first instance, not to mention if the requirements are also vague/incomplete.

The remaining and most challenging of the 'Awaiting Communication' patterns of action (ISD4 → ISD12) triggers what developers (Moscow office) refer to as the 'fire-fighting stage' and relates to the number of vague/incomplete requirements remaining to be developed at the end of a project release to the customer. The key point of this example is the fact that these requirements are considered 'high priority' for the release by the BA/PM and the customer, but remain incomplete in terms of specification. Based, on our analysis, it is the developers who flag the existence of these vague/incomplete requirements to the BA/PM coming toward the end of the release. This creates what is referred to as 'Buffer Time Erosion' pattern of action by the BAs/PMs.

4.2.3 'Buffer time erosion' pattern of action

From the BA/PM perspective the term 'Buffer Time Erosion' suggests that the end of the release is close for the specific project and as one PM suggests "the developers have nothing to do on the project and are awaiting responses on the high priority requirements that are still vague/incomplete in terms of specification". It is important to note that the incompleteness of the requirements is a BA/PM problem and demands an additional execution of the RE process by the BAs/PMs. Therefore, the BA/PM gets the customer to provide a complete specification for the outstanding requirements and passes the details to the developers in the Moscow office. As a result, an ineffective RE process at the outset of the release (the 'BA/PM Helplessness' pattern of action) creates the 'Buffer Time Erosion' pattern of action at a later stage in the release (ISD process) requiring a further attempt at RE by the BA/PM. However, this revisited completion of the specification of requirements triggers the 'Pressure Cooker Development' pattern of action.

4.2.4 'Pressure cooker development' pattern of action

The 'Pressure Cooker Development' pattern of action (ISD13 → ISD6 → ISD11) exists due to the incorporation of vague/incomplete requirements into an existing system release which will need to be researched by developers, prior to writing the code, to avoid technical inconsistencies with existing functionality. As a result, the collective development workload required by developers to complete the release is greater than the time period remaining (see example in 'Awaiting Communication' pattern of action). Therefore, in an effort to complete the project release for the customer, additional developers may need to be seconded to the development efforts to ensure that the release date is not missed. It was reported by developers that this has an impact on the progress made in other projects at that point in time but is a necessary step to ensure customer satisfaction in terms of the delivery of expected functionality. Other issues are caused by this reassignment of developers but they are beyond the scope of what is being specifically addressed in this paper; for example, the late testing of the functionality contained in the release.

5. Summary: ISD as a 'live routine'

Based on our observations and analysis it is obvious that DevCo need a more efficient ISD process. Therefore, the 'performative' aspect of the organisational routine needs to be improved without constraining the enactment of the routine. A set of rules could be suggested to model a partial representation of the 'ostensive' aspect of the organisational routine (ISD process) in an effort to express a "potentially infinite set of performances with a finite set of rules" (Pentland et al., 2010),

p.929). It is worth reiterating that the ‘ostensive’ aspect of a routine is a ‘generative resource’ where actors ‘draw on their understanding of a routine to reproduce it, to plan, guide, and account for their actions with respect to the routine’ (Pentland and Feldman, 2007, p.787). This is similar to the concept of sense making (c.f. (Weick *et al.*, 1999) where the ‘ostensive’ aspects of routines allow actors to recognise and organise diverse parts of a performance (story) as a coherent whole (c.f. Pentland and Feldman, 2007).

Table 6: Ostensive rule to address ISD process inefficiencies

Pattern of Action	Process Inefficiency	Ostensive Rule
BA/PM Helplessness	‘High priority’ customer requirements are not completely specified by BAs/PMs	Every customer requirement that is gathered, if of a ‘high priority’, should be completely specified regarding ‘what the customer wants’ - otherwise its priority is dropped until complete specification is available
Awaiting Communication	Developers seek clarification on ‘high priority’ customer requirements	
Buffer Time Erosion	BAs/PMs return to customer to gather ‘high priority’ requirements before eminent end of release	
Pressure Cooker Development	Developers work under pressure to complete ‘high priority’ requirements for customer release	

In the context of our exploratory case study research a rule could be suggested that defines a valid sequence of action in the ISD process. However, it is important to appreciate that for whatever reason this hypothesised rule (see Table 6), no matter how simple, will not always be attainable in practice. Therefore, while a future failure to completely specify requirements could be generated by expedience, time pressure, customer uncertainty, etc., the organisational actors may be more equipped to appreciate the implications of such a failure and the improvisations that are needed to be made as a result of having a partial representation of the ‘ostensive’ aspect of the organisational routine (ISD process). While we have suggested generating a rule, that defines a valid sequence of action in the ISD process, it is not suggested as imposing structure on the ‘performative’ aspect of the organisational routine, but more to highlight the ‘ostensive’ aspect. As argued by (Fiol and O’Connor, 2003) actions can become routinised if excessively governed by rules and procedures, while more room can be allowed for individual discretion if structures are less specified, allowing for a more fluid, flexible, and adaptive performance (‘performative’ aspect of the organisational routine).

References

- Benbasat, I., Goldstein, D. K. & Mead, M. 1987. The Case Study Research Strategy In Studies Of Information Systems. *Mis Quarterly*, 11, 369-386.
- Byrd, T. A., Cossick, K. L. & Zmud, R. W. 1992. A Synthesis Of Research On Requirements Analysis And Knowledge Acquisition Techniques. *Mis Quarterly*, 16, 117-28.
- Chakraborty, S., Sarker, S. & Sarker, S. 2010. An Exploration Into The Process Of Requirements Elicitation: A Grounded Approach. *Journal Of The Association For Information Systems*, 11, 212-249.
- Eisenhardt, E. M. 1989. Building Theories From Case Study Research. *Academy Of Management Review*, 14, 532-550.
- Fiol, C. M. & O’connor, E. J. 2003. Waking Up! Mindfulness In The Face Of Bandwagons. *Academy Of Management Review*, 28, 54-70.
- Hansen, S. & Rennecker, J. 2010. Getting On The Same Page: Collective Hermeneutics In A Systems Development Team. *Information And Organization*, 20, 44-63.
- Kelliher, F. 2005. Interpretivism And The Pursuit Of Research Legitimation: An Integrated Approach To Single Case Design. *The Electronic Journal Of Business Research Methodology*, 3, 123-132.
- Mathiassen, L., Tuunanen, T., Saarinen, T. & Rossi, M. 2007. A Contingency Model For Requirements Development. *Journal Of The Association For Information Systems*, 8, 569-597.
- Pentland, B. T. & Feldman, M. S. 2007. Narrative Networks: Patterns Of Technology And Organization. *Organization Science*, 18, 781-795.
- Pentland, B. T. & Feldman, M. S. 2008. Designing Routines: On The Folly Of Designing Artifacts, While Hoping For Patterns Of Action. *Information And Organization*, 18, 235-250.
- Pentland, B. T., Hærem, T. & Hillison, D. 2010. Comparing Organizational Routines As Recurrent Patterns Of Action. *Organization Studies*, 31, 917-940.
- Stake, R. E. (Ed.) 2000. *Case Studies*, London: Sage.
- Weick, K. E., Sutcliffe, K. M. & Obstfeld, D. 1999. Organizing For High Reliability: Processes Of Collective Mindfulness. *Research In Organizational Behavior*, Vol. 21, 1999.
- Yeow, A. & Faraj, S. 2011. Using Narrative Networks To Study Enterprise Systems And Organizational Change. *International Journal Of Accounting Information Systems*, In Press, Corrected Proof.

Reproduced with permission of the copyright owner. Further reproduction prohibited without permission.