



Techno-economic projections until 2050 for smaller heating and cooling technologies in the residential and tertiary sectors in the EU

*External study performed by
Planenergi Fond
for the Joint Research Centre*

This is an external study report made for the Joint Research Centre (JRC), the European Commission's science and knowledge service. It aims to provide evidence-based scientific support to the European policymaking process. The scientific output expressed does not imply a policy position of the European Commission. Neither the European Commission nor any person acting on behalf of the Commission is responsible for the use that might be made of this publication.

Contact information

Name: J. Carlsson, European Commission DG Joint Research Centre
Address: Westerduinweg 3, 1755 LE Petten, the Netherlands
Email: johan.carlsson@ec.europa.eu
Tel.: +31-224-565341

JRC Science Hub

<https://ec.europa.eu/jrc>

JRC109034

EUR 28861 EN

PDF ISBN 978-92-79-76014-3 ISSN 1831-9424 doi:10.2760/110433

Luxembourg: Publications Office of the European Union, 2017

© European Union, 2017

Reuse is authorised provided the source is acknowledged. The reuse policy of European Commission documents is regulated by Decision 2011/833/EU (OJ L 330, 14.12.2011, p. 39).

For any use or reproduction of photos or other material that is not under the EU copyright, permission must be sought directly from the copyright holders.

How to cite this report: Hofmeister, M. and Guddat, M., *Techno-economic projections until 2050 for smaller heating and cooling technologies in the residential and tertiary sector in the EU*, EUR28861, Publications office of the European Union, Luxembourg, 2017, ISBN 978-92-79-76014-3, doi:10.2760/110433, JRC109034

All images © European Union 2017

Techno-economic projections until 2050 for smaller heating and cooling technologies in the residential and tertiary sectors in the EU

This study provides techno-economic projections for smaller heating and cooling technologies including an outlook until 2050. The dataset for this study can be downloaded at <http://data.europa.eu/89h/jrc-etri-techno-economics-smaller-heating-cooling-technologies-2017>

Introductory note by JRC

The data quality for costs in this report varies per region. The Danish and German data sets are generally of high quality and more coherent, due to that they had already been systematically collected at national level, and then published in databases or catalogues. The Portuguese and Hungarian data sets were collected from a wide range of sources, and primarily based on inputs from suppliers.

Contents

1	Introduction and methodology	5
1.1	Scope – technologies included	5
1.2	Available Data.....	7
1.3	General description of technology categories	10
1.4	Methodology – general.....	22
1.5	Methodology – projections.....	28
1.6	Structure – sections for each technology	32
2	Technologies – descriptions and data sheets.....	37
2.1	Heat only boilers – oil boiler (condensation)	38
2.2	Heat only boilers – gas boiler (condensation)	45
2.3	Heat only boilers – biomass boiler	53
2.4	Heat only – wood stove.....	60
2.5	Heat pumps, electrical – air to air.....	64
2.6	Heat pumps, electrical – air to water	71
2.7	Heat pumps, electrical – ground source (horizontal/vertical).....	76
2.8	Heat pumps, electrical – groundwater	83
2.9	Heat pumps, electrical – electric ventilation heat pump (exhaust air heat pump).....	86
2.10	Gas driven heat pumps – direct fired absorption heat pump air/brine to water	89
2.11	Gas driven heat pumps – adsorption heat pump brine to water	95
2.12	Gas driven heat pumps – gas engine driven heat pump air/brine to water	99
2.13	Gas driven heat pumps –gas engine groundwater.....	103
2.14	CHP engines – micro turbine.....	104
2.15	CHP engines – internal combustion engine, natural gas & diesel.....	108
2.16	CHP engines – Stirling engine	112
2.17	CHP fuel cells – natural gas fuel cell.....	115
2.18	CHP fuel cells – hydrogen fuel cell	120
2.19	Heat only other – solar heating	124
2.20	Heat only other – electric heating.....	129
2.21	Heat only other – heat storage.....	133
3	Combinations of technologies	136
3.1	Heat pumps and photovoltaic.....	136
3.2	Heat pump and boiler (wood pellet, natural gas, oil)	137
3.3	Boiler (wood pellet, gas, oil) and solar thermal collectors	139

3.4	Heat pump and solar thermal.....	140
3.5	Heat pump with storage	143
3.6	Heat pump and electric boiler	145
3.7	Electric heating and gas based hot tap water heating.....	146
3.8	Pipe network and connection	146
3.9	District Heating substations	151
3.10	Energy savings	157
	References.....	162
	Appendix A: List of Abbreviations and terms	167

List of Figures

Figure 1-1: Overview of the heating and cooling technologies in Portugal.	9
Figure 1-2: Illustration of a compression-heat pump. The function of an engine driven heat pump is similar, as the compressor can be engine- or electrical driven. The main differences to sorption driven heat pumps is the way the refrigerant is regenerated.	12
Figure 1-3: COP of a heat pump as function of the temperature of the heat source. Temperature levels of the central heating system: 25-35°C (return-supply), the cooling of the heat source is 5°C at all operating points. Lorentz-efficiency _{low} : 40%, Lorentz-efficiency _{high} : 60%	13
Figure 1-4: COP of a heat pump as a function of the temperature of the heat source. Temperature levels of the central heating system: 38-52°C (supply-return), the cooling of the heat source is 5°C at all operating points. Lorentz-efficiency _{low} : 40%, Lorentz-efficiency _{high} : 60%	13
Figure 1-5: Climatic zones represented in the data gathering.	24
Figure 2-1: Comparable price data levels, incl. indirect taxes.	37
Figure 2-2: A typical installation of a condensing oil-fired boiler in a single-family house.	38
Figure 2-3: Cascade installation of boilers.	49
Figure 2-4: Biomass boiler, automatic stoking. The fuel tank (left in this illustration) may be installed differently, e.g. as a separate unit or in a separate room, according to the building and the necessary fuel load capacity (according to the intervals that the user wants to be able to be covered, without having to refuel).	54
Figure 2-5: Double duty wood log boiler (manual stoking) prepared for mounting of pellet burner (automatic stoking)	55
Figure 2-6: Wood stove.	60
Figure 2-7: Electrical heat pump, air-to-air.	65
Figure 2-8: Electrical heat pump, air-to-water.	72
Figure 2-9: Electrical heat pump, brine-to-water.	77
Figure 2-10: Electrical heat pump, ventilation.	86
Figure 2-11: Operating principle for gas absorption heat pump.	91
Figure 2-12: Robur E3 heat pump. Air-to-water (left) and ground source options.	92
Figure 2-13: Vaillant zeoTHERM adsorption heat pump, using energy from solar heating.	96
Figure 2-14: Operating principle for gas engine driven heat pump.	99
Figure 2-15: Aisin produces gas engine driven air to water heat pumps.	100
Figure 2-16: Basic principle of a micro turbine.	104
Figure 2-17: Fuel cell principle.	115
Figure 2-18: Fuel cell micro-CHPs supplied with natural gas from the gas grid and delivering surplus electricity to the electrical grid.	116
Figure 2-19: Fuel cell micro-CHPs supplied with hydrogen from an electrolyser and delivering surplus electricity to the electrical grid. The electrolyser can be located either centrally (as in the figure) or locally in each building.	120

Figure 2-20	Example of net efficiencies, electricity to heat, in the hydrogen micro-CHP solution and electric heaters.....	121
Figure 2-21	Small solar heating system for hot tap water. Auxiliary heat is supplied to the upper heat exchanger coil.....	124
Figure 2-22:	Global horizontal Irradiation across Europe.....	127
Figure 3-1:	Illustrations of the hydraulic connections, previously presented as 2 and 3.	141
Figure 3-2:	Example of hydraulic connection of a heat pump for space heating and hot tap water, assisted by a solar thermal collector for hot tap water.....	142
Figure 3-3:	Price-datasheet for a range of buffer tank capacities.	145
Figure 3-4	Example of district heating twin pipes. A steel pipe twin pipe (DN50) 60-60/225 mm (left) and a flexible pipe 14-14/110 mm.....	148
Figure 3-5:	District heating substation with hot tap water heater and heat exchanger for space heating in a one-family house. Indirect coupling, in case of no heat exchanger (in the lower right of the diagram), the system is direct coupling. A branch pipe is connecting the building with the district heating network.	151
Figure 3-6:	District heating substation with hot tap water heater and heat exchanger for space heating.	152
Figure 3-7:	District heating substation with full body insulation for a single-family house.....	153
Figure 3-8:	District heating substation for large buildings	155

List of Tables

Table 1-1: Overview of available datasheets.	8
Table 1-2: Advantages and disadvantages for different boiler types.	11
Table 1-3: Illustration of correlation between the capacity of the drive energy and heat source for different heat pump technologies at typical COP-values. Due to the relationship between input- and drive-energy, a low COP increases the need for drive-energy-effect. The efficiencies of technologies are stated as general values for the given technology. (GEHP=Gas engine driven compression heat pump, GAHP=Directly gas-fired absorption heat pump, EHP=Electrical driven compression heat pump).....	15
Table 1-4: Advantages and disadvantages with different types of heat pumps.....	16
Table 1-5: Advantages and disadvantages of different micro-CHP technologies.	19
Table 1-6: Advantages and disadvantages between other technologies.	20
Table 1-7: Advantages and disadvantages of different combinations of technologies.	21
Table 1-8: Five European zones based on global radiation, cooling degree-days, heating degree-days and cooling potential by night ventilation. (Ecofys et al., p. 149, Table 16)	23
Table 1-9: Technology Readiness Levels, based on EC.	25
Table 1-10: Overview over climatic zones and corresponding cost levels applied.	27
Table 1-11: Sold appliances 2015-30. Based on Dieckhöner & Hecking, cf. footnote 25.	31
Table 1-12: Prediction of sold appliances in the Trend-scenario, Shell-BDH-report, cf. footnote 26.	32
Table 2-1: Techno-economic data for oil boilers. More comments per country are given in the table below.	43
Table 2-2: Techno-economic data for gas boilers. More comments per country are given in the table below.	51
Table 2-3: Maximum values for emissions from (solid) biomass boilers from 2020, cf. EU-Regulation 2015/1189 *Value for biomass fuelled boilers, for solid fossil-fuelled boilers (mainly coal boilers) the limit is 350 mg/Nm ³	56
Table 2-4: Techno-economic data for biomass boilers. More comments per country are given in the table below.	58
Table 2-5: Maximum values for emissions of solid fuel local space heaters, fired with biomass, cf. EU-Regulation 2015/1185 *for solid fossil fuel fired heaters the limit is 300 mg/Nm ³	62
Table 2-6: Techno-economic data for wood boilers. Comments on these data are provided in the table below.....	63
Table 2-7: Requirements for SCOP in average European Climate, cf. EU-Regulation 206/2012.	66
Table 2-8: Techno-economic data for electric heat pumps, air-to-air. Comments on these data are provided in the table below.....	69
Table 2-9: Techno-economic data for electric heat pumps, air-to-water. Comments on these data are provided in the table below.	75

Table 2-10: Techno-economic data for electric heat pumps, ground source. Comments on these data are provided in the table below.	81
Table 2-11: Techno-economic data for electric heat pumps, ground water. Comments on these data are provided in the table below.	85
Table 2-12: Techno-economic data for electric ventilation heat pumps. Comments on these data are provided in the table below.	88
Table 2-13: Techno-economic data for gas driven heat pumps, air brine water. Comments on these data are provided in the table below.	94
Table 2-14: Techno-economic data for gas adsorption heat pumps, brine/water. Comments on these data are provided in the table below.	98
Table 2-15: Techno-economic data for gas airbrine/water heat pumps.	103
Table 2-16: Techno-economic data for CHP engine, micro turbine. Comments on these data are provided in the table below.	107
Table 2-17: Techno-economic data for CHP with internal combustion engine, natural gas. Comments on these data are provided in the table below.	110
Table 2-18: Techno-economic data for CHP with internal combustion engine, diesel. Comments on these data are provided in the table below.	111
Table 2-19: Techno-economic data for CHP sterling engine. Comments on these data are provided in the table below.	114
Table 2-20: Techno-economic data for CHP fuel cell gas. Comments on these data are provided in the table below.	119
Table 2-21: Techno-economic data for CHP fuel cell hydrogen. Comments on these data are provided in the table below.	123
Table 2-22: Techno-economic data for solar thermal. Comments on these data are provided in the table below.	128
Table 2-23: Techno-economic data for electric heating. Comments on these data are provided in the table below.	132
Table 2-24: Techno-economic data for electric heating. Comments on these data are provided in the table below.	134
Table 3-1 Price-datasheet for air-to-water heat pump & natural gas boiler combination.	138
Table 3-2: Price-datasheet for air-to-water heat pump & pellet boiler combination.	139
Table 3-3: Price-datasheet for technology combination of natural gas boiler and solar thermal for hot tap water.	140
Table 3-4: Cost-datasheet for combination of heat pump and solar thermal collector for hot tap water production, cf. the technology combination, described in Figure 3.2.	143
Table 3-5: Cost-datasheet for district heating substations.	156
Table 3-6: Relation between achievable specific demand after refurbishing and costs. Based on Dieckhöner & Hecking, cf. footnote 157.	159

1 Introduction and methodology

The technologies described in this catalogue cover both mature technologies and technologies under development. This implies that the price and performance of some technologies may be estimated with rather high level of certainty whereas in the case of other technologies both cost and performance today as well as in the future is associated with a higher level of uncertainty.

All technologies have been grouped within one of four categories of technological development (described below) indicating their technological progress, their future development perspectives and the uncertainty related to the projection of cost and performance data.

Each technology is described in a separate section, followed by a technology sheet following the same overall format as explained below for both the description and the datasheet.

Contact information:

- JRC:
 - Johan Carlsson, Johan.Carlsson@ec.europa.eu
 - Ronald Piers de Raveschoot, Ronald.PIERS-DE-RAVESCHOOT@ec.europa.eu
- Authors:
 - Morten Hofmeister, PlanEnergi, mh@planenergi.dk
 - Max Guddat, PlanEnergi, mgag@planenergi.dk

1.1 Scope – technologies included

The technologies included comprise:

- Heat only boilers
 - Heat only boilers – oil boiler (condensation)
 - Heat only boilers – gas boiler (condensation)
 - Heat only boilers – biomass boiler (automatic or manual stoking)
 - Heat only boilers – wood stove
- Heating/cooling only – heat pumps - Electric driven heat pumps
 - Heat pumps, electrical – air to air
 - Heat pumps, electrical – air to water
 - Heat pumps, electrical – ground source (horizontal/vertical)
 - Heat pumps, electrical – electric ventilation heat pump (exhaust air HP)
 - Heat pumps, electrical – groundwater
- Heating/cooling only – heat pumps - Gas driven heat pumps
 - Gas driven heat pumps – absorption heat pump air/brine to water
 - Gas driven heat pumps – adsorption heat pump brine to water
 - Gas driven heat pumps – gas engine driven heat pump air/brine to water
 - Gas driven heat pumps –gas engine groundwater
- CHP
 - CHP engines – micro turbine
 - CHP engines – internal combustion engine, natural gas
 - CHP engines – internal combustion engine, diesel
 - CHP engines – Stirling engine
 - CHP fuel cells – natural gas fuel cell
 - CHP fuel cells – hydrogen fuel cell
- Heat only – other
 - Heat only other – solar heating
 - Heat only other – electric heating
 - Heat only other – heat storage

Combinations of technologies are included (cf. Section 1.1.1), combining two or more technologies. These combinations could also imply connecting more than one building, based on renewable energy sources, based on affordable proven technologies with an expected significant scope for deployment. The following criteria apply ("Note of information No. 1" dated 24/11/2015¹):

- based on renewable energy sources;
- affordability;
- scope for deployment;
- proven technology;
- available data/information.

A general introduction to the technology categories and the basic functioning is in section 1.2 below. This section on general descriptions is supplemented by the more specific descriptions of the technologies in section 2 below.

1.1.1 Combinations of technologies

Combinations of technologies may be relevant due to different reasons; technical characteristics or application to more than one building.

Technologies have different characteristics with regard to fulfilment of the demand. E.g. solar thermal will not be able to fulfill the demand during all year, i.e. technical limitations, or it may be more viable to have two or more different technologies supplementing each other in fulfilling the demand.

Key characteristics of some technologies make it relevant to combine two or more technologies. This e.g. applies for solar thermal, but could also apply for heat pumps. A key feature of these combinations is that the sensitivity of the heat price will decrease, since the different types of energy sources/fuels are applied. Hence, the combinations are relevant from a technical perspective – being able to fulfil the demand for heating and hot water, and from an economical perspective enabling minimisation of the operation costs according to different fuel costs etc.

Some combinations are available on the market as of-the-shelf products, whereas other combinations combine the characteristics from the single technologies.

- heat pumps and photo voltaic;
- heat pump and wood pellet boiler;
- solar heating and wood pellet boiler;
- heat pump with storage;
- heat pump air/water and ground source;
- heat pump and natural gas boiler;
- heat pump and electric boiler (integrated);
- heat pump and solar thermal;
- pipe network and connection;
- district heating substations.

Applications of larger capacity are enabled by the establishment of a pipe network. Even though the focus is on individual technologies serving a single building, it could

¹ Elaborating information regarding the tender material.

be relevant to consider connection of a few buildings. This could be categorized as “small-scale collective energy plants” combining the advantages of the small-scale applications and the synergies of collective heating and cooling systems.

Hence, application of larger capacity units is possible also for single-family houses connected by a pipe network.

Consequently, inclusion of costs of house installations is also relevant. Costs of house installations and possible changes to the central heating system may vary due to requirements for a level of temperature (e.g. in Germany this results in higher costs).

In addition to this, the demand side is also crucial to consider; including energy savings may influence the competitiveness of certain technology choices, due to e.g. decreased needs for thermal capacity and resulting capacity factors. Hence, energy savings should be included in total cost assessments. Estimates for costs of energy improvements / renovation are presented in the end of the study at hand.

1.2 Available Data

Focus of this catalogue is on the heating and cooling capacity. Some technologies are not suitable for providing e.g. all heating in a building. This is indicated in the fields “expected share of heating demand (%)” and “expected share of hot tap water demand (%)”. There may also be regional differences as well as typical combinations of technology.

Data for two different sizes of capacity have been collected. This addresses the different applications (one-family house, multi-family building and office building) as well as the “existing” and “new” building. Specific ranges of capacities are indicated in the data sheet for each technology.

An overview over the technologies covered in this study is given in the table below. Due to limitations in data availability, not all technological alternatives are represented in the datasheets. Technologies marked with a “1” are represented in the datasheets, whilst an “0” indicates that no data have been identified for the given technology, in the given region.

Table 1-1: Overview of available datasheets.

Overview of datasheets

Datasheet	Country Denmark	Portugal	Hungary	Germany
HOB-oil	1	1	1	1
HOB-oil, large	1	1	0	1
HOB-gas	1	1	1	1
HOB-gas, large	1	1	1	1
HOB-biomass	1	1	1	1
HOB-biomass, large	1	1	1	1
HOB-wood	1	1	1	0
HP-e-air-to-air	1	1	1	1
HP-e-air-to-air, large	0	1	0	0
HP-e-air-to-water	1	1	1	1
HP-e-air-to-water, large	1	1	0	0
HP-e-ground	1	1	1	1
HP-e-ground, large	1	0	0	1
HP-e-groundwater	0	0	1	1
HP-e-ventilation	1	1	0	1
HP-e-ventilation, large	1	0	0	1
GHP-a-air/brine-water	1	0	0	0
GHP-a-air/brine-water, large	1	0	1	1
GHP-eng-air/brine-water	1	0	0	0
GHP-ad-brine-water	1	0	0	0
GHP-eng-groundwater	0	0	0	0
CHP-eng-micro-turbine	0	0	1	0
CHP-eng-micro-turbine, large	0	0	1	0
CHP-eng-gas	1	1	0	1
CHP-eng-gas, large	1	1	1	0
CHP-eng-diesel		0	0	1
CHP-eng-stirling	1	0	1	0
CHP-eng-stirling, large	1	0	0	1
CHP-fc-gas	1	1	0	1
CHP-fc-hydrogen	1	1	0	0
Solar	1	1	1	1
Solar, large	1	1	1	1
Electrical	1	1	1	1
Electrical, large	1	0	1	1
Storage		1	1	1
Comb-HP-PV		0	1	0
Comb-HP-wood pellet boiler		0	0	0
Comb-solar-wood pellet boiler		0	0	1
Comb-HP-storage		0	0	1
Comb-HP-air-water and ground source		0	0	1
Comb-HP-gas boiler		0	0	1
Comb-HP-electrical boiler		0	0	1
Comb-HP-solar		0	0	1
Pipe network, conventional	1	0	1	0
Pipe network, low temperature	1	0	0	0
House installations	1	0	1	0
Energy savings		0	1	1

The following sections include descriptions of technology categories, including advantages and disadvantages. Key points from these sections are included here, in order to provide an overview of the suitability of the different types of technologies.

1.2.1 Market shares of technologies

This report does not comprise analyses of the market shares of the different technologies for heating and cooling in different European countries. A few points regarding market deployment are provided in the following sections.

The Heat Roadmap Europe project includes analyses of the stock of different technologies. This can be useful to estimate the significance of the development of different technologies. This reference e.g. includes figures for the number of installed natural gas boilers in Europe, as well as the installed capacity of natural gas, oil and coal boilers.²

An overview of the heating and cooling technologies in Portugal is provided in Figure 1-2:

Energy use one-family house (2)		Avg. total Energy cons. [kWh/m2]	90.0
Cooking [%]	36.9		
Hot water [%]	31.3	Avg. Salary installer (€/h) (3,4)	5.3
Appliances [%]	16.3		
Lighting [%]	6.7		
Heating [%]	8	# dwellings equipped with [%]	
Cooling [%]	0.8	Heating	78.3
		Cooling	22.6
Type heating system (1,A)	Type cooling system (1)	Hot water production system (1)	
Electric [%]	Electric ventilator [%]	Gas boiler	78.6
Wood stove [%]	HP air-to-air [%]	Electric boiler w/storage	11.2
Biomass [%]	AC (1) [%]	Gas boiler (space heating+hot water)	11.9
Gas boiler [%]		Solar thermal	1.8
Gas burner [%]			
HP air-to-air [%]			

Figure 1-1: Overview of the heating and cooling technologies in Portugal.

Notes
A. AC is a heat pump only used for cooling. HP is used for both heating and cooling
B. The sum of this table is more than 100% because they can be a combination of different heating systems in the same house. For example, a house can have both an electric heater and a wood stove.
C. http://www.euromonitor.com/heating-appliances-in-portugal/report
References
1. INE - National Institute of Statistics, Energy use in the domestic sector, Summary in english - "Inquérito ao Consumo de Energia no Sector Doméstico" pages 75-79
2. INE, 2010 Preliminary results of the energy use in domestic sector, only portuguese
3. www.meusalario.pt
4. https://www.economias.pt/calculo-do-salario-liquido/?remuneracao=1163&valorsubref=&valoroutrasrenums=&enquadramento=nao-casado&tiposubref=remun&dependentes=#simulador-salario-liquido-2016
5. EHPA, "Market Statistics 2015"

1.2.2 Boiler technologies

Boilers are characterised by requirements for:

- Space for the installation
 - Space for fuel storage (e.g. biomass)
- Availability of fuel
 - Infrastructure for handling of fuel, e.g. biomass or gas.

² <https://ec.europa.eu/energy/sites/ener/files/documents/Report%20WP2.pdf>

A gas boiler is dependent on a natural gas distribution network and a biomass boiler requires availability of fuel.

1.2.3 Heat pump technologies

Heat pumps make use of different kinds of heat sources.

Space is required for the heat pump itself as well as the infrastructure for collecting the heat from the heat source.

Visual impact and noise can be important aspects to observe in relation to heat pumps.

1.2.4 Other non-combustion heating, energy storage & energy conservation

Solar thermal is limited by variations in solar irradiation – geographical and local. Often the roof can be used, but this has limited area (relevant for multi-storey houses) and requires investigation of the roof construction.

Storage for diurnal variations is an advantage in combination with solar thermal.

1.3 General description of technology categories

1.3.1 Boiler technologies

A widely applied group of heating technology is boiler technologies. The conceptual function of boilers is to generate heat in a combustion chamber/burner through combustion of a fuel. The generated heat in this combustion is applied for heating water for space heating and/or hot tap water demands. The heated water is distributed in a water based heat distribution system on apartment or building-level. The applicable fuels are e.g. light fuel oil, natural/bio-gas or solid biomass.

The load of most modern boiler technologies can be varied almost instantaneously according to the heat demand, eliminating or limiting the need for heat storage. Manually stoking biomass boilers are an exception of this rule, as the heat load is varied by regulation of the fed in air and fuel.

Boiler technologies form the major heating technology across Europe, with light fuel oil and natural gas boilers being the predominant fuels.

Advantages and disadvantages of boiler technologies

Advantages and disadvantages of the boiler technologies covered by this catalogue are elaborated in the technology descriptions, later in this report. These advantages and disadvantages are also collected in this section to present an overview.

Oil and gas boilers have the general advantage of a high comfort level related to their use, as the maintenance is limited to an annual maintenance check. Oil and biomass boilers also require ordering and delivery of fuel). Automatic stoking biomass boilers also regulate according to the heat demand. However, there is some work related to the clearing of the ashtray.

Manual stoking boilers and biomass stoves are generally less comfortable as a primary heating technology, as the fire has to be lighted by the consumer nearly simultaneously to changes in demand, see Table 1-2.

Table 1-2: Advantages and disadvantages for different boiler types.

Boiler type	Advantages	Disadvantages
Domestic fuel oil, condensing	<ul style="list-style-type: none"> • Simple and reliable technology • High thermal efficiency 	<ul style="list-style-type: none"> • Environmental consequences
Natural gas, condensing	<ul style="list-style-type: none"> • High thermal efficiency • CO₂- and NO_x-emissions lower than for any other fossil fuel • Grid-based fuel distribution very efficient 	<ul style="list-style-type: none"> • Environmental consequences
Biomass, automatic stoking	<ul style="list-style-type: none"> • CO₂-neutral combustion as fuel is biomass. • Can typically replace an existing boiler without requiring a change of the central heating system 	<ul style="list-style-type: none"> • Large variation in initial investment, depending on product quality • Large space demand for boiler and fuel storage & supply system • Cleaning of boilers
Biomass, manual stoking	<ul style="list-style-type: none"> • New generation with fewer emissions due to downwards-draught combustion. 	<ul style="list-style-type: none"> • Heat storage needed to sustain a reasonable level of comfort. • Cleaning of boilers
Wood stove	<ul style="list-style-type: none"> • Cost-effective installation 	<ul style="list-style-type: none"> • Non-automatized combustion and choice of fuel create possibility for non-optimized combustion (due to users' faults), resulting in possible local (particle) pollution • Limited possibilities for thermal output

1.3.2 Heat pump technologies

Heat pumps employ the same technology as refrigerators, moving heat from a low-temperature location to a warmer location. Heat pumps usually extract heat from the ambience (input heat) and convert the heat to a higher temperature (output heat) through a closed process, with additional driving energy in the form of heat or electricity.

The energy efficiency of heat pumps is normally referred to by the COP factor "Coefficient of Performance", describing the delivered heat divided by the used drive energy (fuel in thermal driven heat pumps or electricity). A COP of 3 means that the heat pump delivers three times as much heat as the drive energy (electricity consumption in an electrical compression heat pump), and two thirds of the delivered heat are collected through the outdoor heat exchanger.

Heat pumps are categorized according to their design or operational principle as follows:

- Compressor-driven heat pumps
 - Driven by electricity
 - Driven by gas engines
- Sorption heat pumps, driven by gas or heat ("thermally driven" heat pumps)
 - Absorption heat pumps
 - Adsorption heat pumps

Other types can be found as well (Vuilleumier etc.), but are mostly in an R&D stage and are not treated in the present document.

Both types of heat pump technologies require a heat source (in the residential sector typically low temperature heat sources like ambient air or ground source) and a drive energy; electricity in electrical heat pumps and the respective fuel in thermally driven sorption heat pumps.

This catalogue covers heat pumps installed with the purpose of covering a space heating or cooling demand. Aside these, heat pumps only covering hot tap water demands do exist, but are not included in this study.

Electrical heat pumps

The figure below presents the basic principle of compressor-driven heat pumps. Heat pumps consist of a low- and a high-pressure zone, which corresponds with the pressure level of the refrigerant being circulated in the heat pump. The intake of the heat source is the low-pressure zone, where the condensed refrigerant evaporates due to the thermal effect of the heat source (1 on the figure below). This implies that the heat source is being cooled down. In compression heat pumps, the pressure of the refrigerant is then raised in a compressor (2 on the figure below), resulting in an increase of temperature. The water in the heating installation (3 on the figure below) is used to regenerate the refrigerant, by cooling the refrigerant and thus heating water (in ventilation systems and other air based heat distribution systems: air). The pressure in the high-pressure zone is regulated through an expansion valve (4 on the figure below), creating a flow of the refrigerant and resulting in a continuous process.

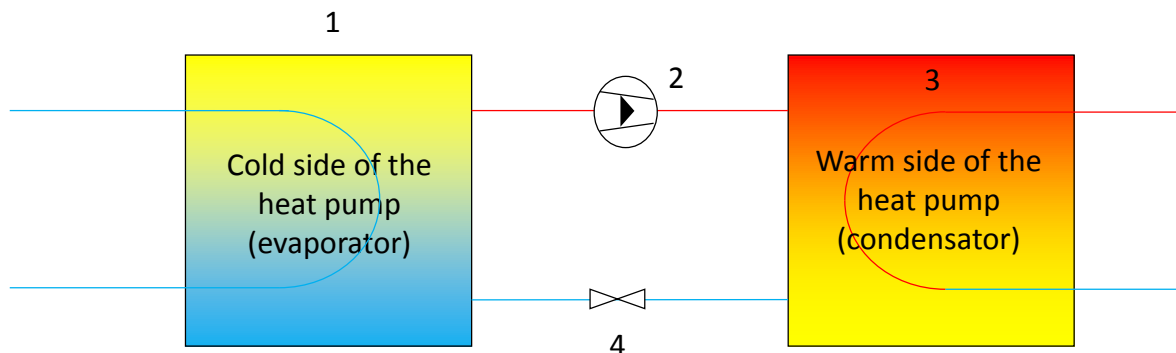

1: evaporator, 2: compressor, 3: condensator, 4: valve

Figure 1-2: Illustration of a compression-heat pump. The function of an engine driven heat pump is similar, as the compressor can be engine- or electrical driven. The main differences to sorption driven heat pumps is the way the refrigerant is regenerated.

The COP of electrical heat pumps is a function of the temperature of the heat source (in this case the ambient temperature) and the temperature of the heat sink (in this case the supply temperature in the central heating system). Therefore, the energetic performance of electrical heat pumps should be evaluated according to local conditions and thus be evaluated as a Seasonal Coefficient Of Performance (SCOP) when comparing with other alternatives. In the following figures, the COP of an electrical driven heat pump is illustrated as a function of the temperature of the heat source.

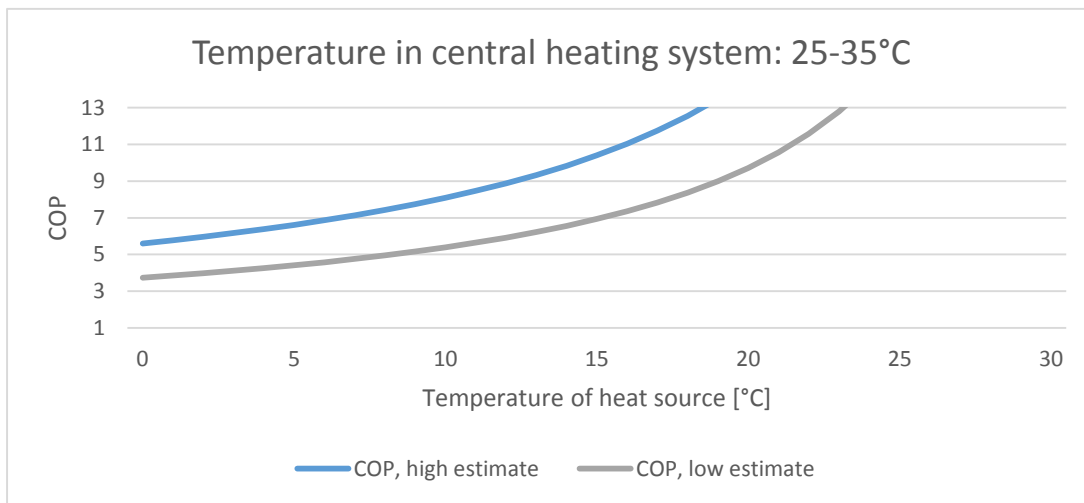

Figure 1-3: COP of a heat pump as function of the temperature of the heat source. Temperature levels of the central heating system: 25-35°C (return-supply), the cooling of the heat source is 5°C at all operating points. Lorentz-efficiency_{low}: 40%, Lorentz-efficiency_{high}: 60%

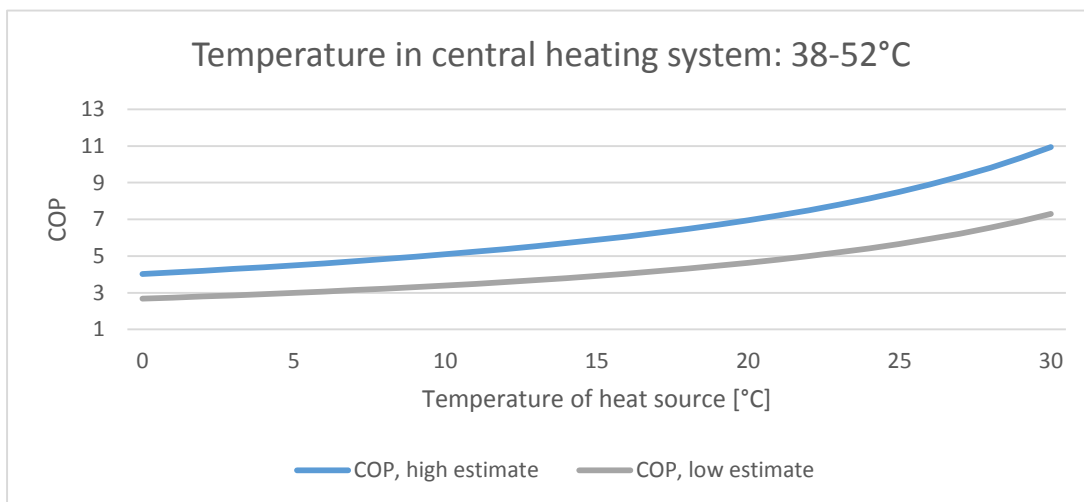

Figure 1-4: COP of a heat pump as a function of the temperature of the heat source. Temperature levels of the central heating system: 38-52°C (supply-return), the cooling of the heat source is 5°C at all operating points. Lorentz-efficiency_{low}: 40%, Lorentz-efficiency_{high}: 60%

As illustrated in Figure 1-3 and Figure 1-4, the temperature sets of the central heating system (and the difference between supply and return) of the building has a crucial influence on the COP of the heat pump. The range of the temperature of the heat source is chosen according to what is estimated to be reasonable operating points within the context of this catalogue. Please note that the supply and return temperatures in buildings are subject to regional specific factors like building traditions, regulations and comfort preferences by the consumers and hence vary across Europe. The above chosen temperature sets are chosen in order to illustrate the difference between typical temperature sets in a building with floor heating (25-35) and a modern radiator heating system (38-52).

The thermal load of electrical heat pumps can generally be regulated as on/off or by varying the operation speed of the compressor, thus regulating the flow of the refrigerant. For many models, it is possible to vary the compressor speed continuously from approximately 20-100 % of nominal capacity. In on/off regulation, the compressor will work full load and stop at intervals adapted to the heat demand.

Gas heat pumps

Gas heat pumps are either thermally driven (absorption and adsorption) or mechanically driven (gas engine heat pumps). Geothermal heat, groundwater or surface water, the sun and the air are all suitable as natural sources of heat. In absorption heat pumps, high temperature heat is used to regenerate a refrigerant that can evaporate at a low temperature level and hereby utilize low grade energy. Energy from both drive heat and the low temperature heat source is delivered at a temperature in between.

The energy efficiency of gas heat pumps is usually expressed in per cent and not in COP factor "Coefficient of Performance", as for the electrical heat pumps. The highest net efficiency measured for a gas heat pump **in heating mode** has today reached approximately 170 % (COP = 1.7) (value obtained on absorption heat pump). In theory, 1 kJ of heat can regenerate around 1 kJ of refrigerant meaning that an absorption heat pump has a theoretical energy efficiency of around 200 %. Due to losses in the system the practical COP is around 1.7. For absorption heat pumps, the COP is less affected by temperature levels as for compression heat pumps. Certain temperature differences are required to have the process going, but as long as these are met the COP will be approximately 1.7 and not affected by further temperature increase of the drive energy.

The main difference to the process described in **Figure 1-2** is the way that absorption heat pumps regenerate the refrigerant. In absorption heat pumps, the refrigerant (often ammonia) is evaporated due to the thermal energy from the heat source. A second liquid (the absorbent, e.g. water) then absorbs it. The solvation is hereafter heated by the drive energy in order to evaporate it. The gaseous solvation is then condensed by a heat exchanger, using the energy content in the phase shift to heat e.g. the water of a central heating system. The absorbent is thus recirculated in order to once again be evaporated by the evaporated refrigerant. The energy efficiency of 170 % seems considerably lower than the COP for electric heat pumps. However, when considering the present energy efficiency for the average power generation, the efficiency of electrical heat pumps and gas heat pumps become closer to each other. One method to compare the performances of the two types of heat pump is to calculate the efficiencies based on primary energy use. This is applied for the EU Ecodesign LOT 1 and 2³, where the present conversion factor is 2.5 (i.e. the COP of electrical heat pumps should be divided by 2.5 to have a comparable efficiency figure).

Note that the real primary energy factor depends on the production of electricity (e.g. fossil, nuclear, renewable etc.), which varies considerably by country and will also fluctuate and evolve with time.

Due to the lower efficiency of gas heat pumps (compared to electric heat pumps), less energy from the outside air, ground etc. will be collected to the heat pump. Therefore, the design of gas heat pumps is different from that of electrical heat pumps (EHP). This means smaller heat exchangers for the energy source, fewer bore holes, shorter tubes in the ground.

Another consequence is that gas heat pumps are less dependent on variations in the energy source temperature compared to the electric heat pumps. A larger part of the energy comes from the fuel input and less from the (free) heat source (compared to electrical heat pumps).

The economic characteristics of gas driven and electric heat pumps must always be compared in a total economic perspective comprising investment and operation costs of the alternatives, including all necessary component costs for the given alternative

³ Lot 1: boilers and combi boilers, Lot 2: water heaters. Ecodesign Regulation 813/2013

installations. This is mainly due to potential differences in the dimensioning of the heat source, as exemplified in the table below. The heat source for a gas driven heat pump can be smaller than the heat source for an electric heat pump, as the drive energy in a gas driven heat pump supplies a larger share of the total energy input. Please refer to the data sheets in Chapter 2 for prices.

Table 1-3: Illustration of correlation between the capacity of the drive energy and heat source for different heat pump technologies at typical COP-values. Due to the relationship between input- and drive-energy, a low COP increases the need for drive-energy-effect. The efficiencies of technologies are stated as general values for the given technology. (GEHP=Gas engine driven compression heat pump, GAHP=Directly gas-fired absorption heat pump, EHP=Electrical driven compression heat pump)

	GEHP	GAHP	EHP
COP	1.5	1.7	3.5
Heat output (kW)	20	20	20
Drive-energy (kW)	13.3	11.8	5.7
Heat source (kW)	6.7	8.2	14.3

* natural gas / electricity

Different heat sources

Heat pumps are also differentiated by the ways used to collect heat from the free source and ways used to distribute the heat in the house.

- air-to-Air heat pumps draw heat from ambient air and supply heat locally through air heat exchangers;
- air-to-Water heat pumps draw heat from ambient air and supply heat through a hydraulic heat distribution system (radiator, convectors, floor heating);
- brine-to-Water heat pumps are generally taking heat from the ground using water pipes and are distributing heat in the house via a hydraulic system (radiator, floor heating etc.).

In theory, heat pumps utilizing heat from ambient air will achieve a lower thermal efficiency during the heating season compared to brine-to-water heat pumps. In practice, however, there is often only little difference in efficiency for heat pumps using air as the heat source and the brine or water-based alternative. Furthermore, some existing buildings do not have enough space to construct a ground source, making it necessary to find solutions that limit the (outdoor) space requirements for the heat source as much as possible, either by choosing an air to air or air to water heat pump.⁴ There are three major technologies for utilizing heat in the soil by circulating a fluid (typically an alcohol-water solution to prevent freezing):

1. Horizontal collector systems: Pipes that are installed by digging them into the ground at approximately 1-2 m (in order to decrease temperature variations). Similar systems use flat absorbers or trench systems in order to limit/differ the necessary earthworks. Furthermore, pipes can be installed in horizontal layers.

⁴ Energinet.dk; Danish Energy Agency. Technology Data for Individual Heat Production and Energy Transport. Copenhagen: Energinet.dk, 2013. AND GasTerra. Gas Heat Pumps. Efficient Heating and Cooling with Natural Gas. Groningen: Csatel International Publishers, 2010.

⁵ BWP. Leitfaden Erdwärme. Berlin: Information document by the German Heat Pump Association (BWP), 2014 AND

2. Vertical collector probes, drilled into the ground at approximately 100-200 m, less space consuming, very stable temperatures. The needed depth is very much dependent on the soil materials, water content of the soil etc.⁶ There are currently no air-to-air gas heat pumps available on the market for residential heating purposes. Gas driven heat pumps are thus only available for buildings with water based central heating systems, whereas electrical air-to-air heat pumps for the heating of single rooms do exist.⁷

In principle, all gas driven heat pump technologies are reversible and can also be applied for cooling/air conditioning, but not all products on the market may be designed for cooling also.

Advantages and disadvantages of heat pump technologies

Advantages and disadvantages of the heat pump technologies covered by this catalogue are elaborated in the technology descriptions, later in this report. These advantages and disadvantages are collected in this section to present an overview. A general advantage of heat pumps is their ability to utilize a free heat source, typically ambient air or heat in ventilation air that otherwise would be emitted to the surroundings of the building under investigation. Electrical heat pumps (EHPs) that deliver heat to a waterborne central heating system can contribute to a smart energy system as a flexible demand, when combined with heat storage, as the heat production can be different from the heat demand on a given point of time.

Table 1-4: Advantages and disadvantages with different types of heat pumps.

Heat pump	Advantages	Disadvantages
Electrical, air-to-air	<ul style="list-style-type: none"> • Can be a relevant option in buildings without a waterborne central heating system • Simple installation, no earthwork operations required • Typically low investment costs • Reversible air-to-air HPs can cover both heating and cooling demands 	<ul style="list-style-type: none"> • Generally low convergence between optimal operation conditions and high heat demands • One unit per room or other technologies for other rooms needed • In humid periods, ice may build on the outdoor-units, decreasing the efficiency • Cheaper products may cause noise pollution • Efficiency dependent on outdoor temperature and supply temperature to heating system. Thus least efficient in cold periods, when demand is highest.
Electrical, air-to-water	<ul style="list-style-type: none"> • Higher COP in the heating season than e.g. air-to-air HPs • Simpler installation than e.g. ground source HPs 	<ul style="list-style-type: none"> • Cheaper products may cause noise pollution • Efficiency dependent on outdoor temperature and supply temperature to heating system. Thus least efficient in cold periods, when demand is highest.

UMBW. Leitfaden zur Nutzung von Erdwärme mit Erdwärmekollektoren (engl: Analysis Report on the use of geothermal heat through heat collector technologies). Stuttgart: Environmental Ministry of Baden-Württemberg (UMBW), 2008.

⁶ BWP. Leitfaden Erdwärme. Berlin: Information document by the German Heat Pump Association (BWP), 2014.

⁷ Aisin. GHP E Gas Heat Pump. Brochure: Tecnozaa Climatizzazione.

Electrical, air-to-water		<ul style="list-style-type: none"> • Most models have a max. output temp. of 55-60°C, thus requiring a continuous flow water heater for higher temperatures or peak demands. • A high SCOP may require an adjustment of the central heating system (i.e. additional investments)
Electrical, brine-to-water	<ul style="list-style-type: none"> • Higher COP in heating season than e.g. air-to-air and air-to-water HPs • Less variation in COP throughout the year • The same unit can cover space heating and hot tap water demands • No potential noise pollution from outdoor unit 	<ul style="list-style-type: none"> • Most expensive EHP-technology • Additional investment for ground-source heat collector. • A high SCOP may require an adjustment of the central heating system (i.e. additional investments) • Installation of brine-system may require earth work to be carried out (additional investment)
Electrical, groundwater	<ul style="list-style-type: none"> • High temperature-stability of energy source, thus low variation in COP due to heat source • Other advantages same as four ground source 	<ul style="list-style-type: none"> • High investment costs • Use of ground water for energy purposes may be restricted • Nearest aquifer may be too deep to reach with a simple well • Safety measures to prevent decontamination of groundwater need to be taken • Increased electricity consumption for pumping
Electrical, ventilation air	<ul style="list-style-type: none"> • Possibility to increase fuel efficiency by recirculating (parts of) the waste heat that would otherwise be emitted from the building 	<ul style="list-style-type: none"> • Requires a ventilation system, which may be expensive or impossible to implement in existing buildings • Thermal capacity is limited by the exhaust heat from the building and not all energy losses can be utilized
Gas, absorption	<ul style="list-style-type: none"> • Mature technology, e.g. to replace existing gas boilers • Higher fuel efficiency of natural gas than e.g. boilers 	<ul style="list-style-type: none"> • Very limited product variety on the market
Gas, adsorption	<ul style="list-style-type: none"> • Easy to replace gas boilers • Zeolithe (refrigerant) has GWP=0, opposed to HFC-refrigerants in most heat pumps 	<ul style="list-style-type: none"> • Lower limit for heat source of approximately 2°C, i.e. solar thermal or ground source heat are necessary to secure lower limit is reached • Slightly lower fuel efficiency than e.g. absorption heat pumps

		<ul style="list-style-type: none"> • Very limited product variety on the market and limited operation experience
Gas, engine driven compressor	<ul style="list-style-type: none"> • Mature technology for commercial purposes • High SEER, compared to other gas heat pumps and thus a good technology when cooling is also needed 	<ul style="list-style-type: none"> • Currently, the technological development is focusing on commercial appliances • Noise from the engine may be an issue

1.3.3 Micro combined heat and power generation (micro-CHP)

Micro-CHP technologies combust a fuel (in small-scale applications typically natural gas) and generate both electricity and heat. micro-CHP-appliances are typically dimensioned according to a combination of the electricity and heat demand, in order to limit the investment in CHP-capacity. The heat capacity of the CHP-unit will thus typically cover the baseload heat demand of the building and be installed with an additional peak load gas boiler to cover demands that exceed the heat production of the CHP-unit.

Natural gas fuelled micro-CHP can be an alternative in areas with an existing natural gas distribution system. Depending on the national regulation of small-scale electricity production, micro-CHP may also be a user-economic friendly alternative, as it decreases the need for electricity import from the electricity grid. The combustion technologies are typically Internal Combustion- or Stirling engines. In larger appliances, microturbines may be a possibility. For small appliances or island solutions, diesel or domestic fuel oil may be an option.

Furthermore, fuel cells are an option for coproduction of heat and power on building scale. Fuel cells either can utilize hydrogen (when available purified) or be combined with a reformer, producing the demanded hydrogen from natural gas. There are fuel cells on the market that are designed for the connection to the natural gas grid that have a reformer integrated. Fuel cells can be used in different applications including stationary applications in households as micro-CHP units, where the fuel cell produces both electricity and heat to the household.

Hence, most existing micro-CHP-appliances necessitate a connection to the natural gas grid. When the electricity production exceeds the consumption, it can be exported to the electrical grid. Opposite, when the electricity production is less than the consumption, additional power will be supplied from the grid. Thus, micro-CHP should always be combined with a connection to the electrical grid.

Advantages and disadvantages of micro-CHP technologies

Advantages and disadvantages of the micro-CHP technologies covered by this catalogue are elaborated in the technology descriptions, later in this report. These advantages and disadvantages are collected in this section to present an overview.

Table 1-5: Advantages and disadvantages of different micro-CHP technologies.

Micro-CHP	Advantages	Disadvantages
Micro turbine	<ul style="list-style-type: none"> • High power-to-weight ratio, compared to many other CHP-technologies • Many hours-of-operation in lifetime, due to only one moving part and hence little wear of components • Little local environmental hazards due to lubricants and coolants, as air-cooling and foil-air bearings are an option • Exhaust heat aggregated at high temperature, making utilization simple and efficient 	<ul style="list-style-type: none"> • Relatively slow load shift (compared to piston engines) on the generator • Efficiency losses with decreasing capacity
Internal combustion, natural gas or diesel/oil	<ul style="list-style-type: none"> • Mature technology, increasing maturity in small-scale too • Possible direct replacement of existing boiler technologies 	<ul style="list-style-type: none"> • Higher noise level than e.g. boilers • Higher demand of service and maintenance than e.g. boilers
Stirling engine	<ul style="list-style-type: none"> • Low emissions and little vibrations • Long lifetime and long service intervals, longer than e.g. piston-engines • Low noise level 	<ul style="list-style-type: none"> • Operation at high pressure results in difficulties with bearings • Limited possibilities for part-loads • Long start-up periods and high energy demand for start-up
Fuel cell, natural gas	<ul style="list-style-type: none"> • Simple way to replace existing natural gas boilers • High fuel efficiency • Low noise level 	<ul style="list-style-type: none"> • Dependant on natural gas supply • Niche technology and still relatively high costs
Fuel cell, hydrogen	<ul style="list-style-type: none"> • Can serve as indirect electricity storage in the energy system • Independent of the natural gas grid, when installed with electrolyser • High electrical efficiency, compared to other micro-CHP-technologies • Low noise level 	<ul style="list-style-type: none"> • Dependant on hydrogen supply/distribution if not installed with decentralised reformer or electrolyser • System losses related to electricity-hydrogen-electricity/heat transformation • Niche technology and still relatively high costs

1.3.4 Other non-combustion heating, energy storage & energy conservation

This catalogue also covers a group of technologies that do not necessitate the combustion of a fuel for the heat generation. The technologies treated in this section are solar heating and electric heating – heat pumps are included in the above sections. Solar heating technologies treated in this catalogue are flat panel and vacuum tube collectors. Electric heating panels (possibly including night storage) are chosen as the technology to represent electric heating technology.

Further technologies that are treated in this catalogue are thermal energy storage and energy conservation. Thermal energy storage is primarily relevant in combination with

a heat production technology, as it e.g. increases the possibility of flexible heat production and makes it possible to operate boilers in on/off mode instead of less-efficient partial load. Energy conservation measures that result in a lower heat demand and less energy loss through the building envelope effectively reduces the necessary heating capacity. For compression heat pumps, the reduction of heat loss also results in higher efficiencies, as the same heat pump can be operated at lower flow temperatures, when the needed heating effect is lower.

Advantages and disadvantages of other technologies

Advantages and disadvantages of the above-mentioned technologies covered by this catalogue are elaborated in the technology descriptions, later in this report. These advantages and disadvantages are collected in this section to present an overview.

Table 1-6: *Advantages and disadvantages between other technologies.*

Other technology	Advantages	Disadvantages
Solar heating	<ul style="list-style-type: none"> • Low operation costs. • Unlimited heat source • Limits operation costs of primary heating installation, i.e. by displacing summer-partial load of boilers for hot tap water demand. 	<ul style="list-style-type: none"> • Production is weather dependent (solar irradiation, time of day, other weather conditions). Seasonal mismatch between peak demand and availability. • Expensive installation, especially on existing roofs • May compete with PV when limited appropriate roof area is available
Electric heating	<ul style="list-style-type: none"> • Easy installation at low installation costs • No central heating system required • High level of comfort with quick response and easy possibilities for remote control 	<ul style="list-style-type: none"> • High quality energy product used for low quality purpose, in a process that is not as efficient as e.g. electrical heat pumps. • High demand for electric distribution capacity, when applied widespread.
Heat storage	<ul style="list-style-type: none"> • Enabling utilization of e.g. solar and reducing requirements for size of production capacity by reducing the dependency in time of production and demand for heating. 	<ul style="list-style-type: none"> • Space requirement. • Possible losses

1.3.5 Combination of technologies

Besides the single technologies, an overview over possible setups of combinations of heat producing units is presented. The list is non-exhaustive, but it is the intention of the authors to present documented well-functioning examples of combinations. As the applicability of these combinations is highly dependent on the local application, the building under investigation etc. the description of these combinations is limited to a qualitative examination. The list is inspired by, but not limited to, combinations that can be purchased as an integrated solution by consumers, thus increasing the applicability as e.g. the control and regulation of these integrated solutions is easier and thus cheaper than when the integration is done on project-level, e.g. by the local contractor.

Advantages and disadvantages of combinations of technologies

Advantages and disadvantages of the covered combinations of technologies covered by this catalogue are elaborated in the technology descriptions, later in this report. Combinations of technologies are described based on the marginal difference to having the corresponding technologies as monovalent technology-installations. A general disadvantage of the combinations is thus that there will be two or more heat sources to maintain, which adds an extra expense in the operational phase. These advantages and disadvantages are collected in this section to present an overview.

Table 1-7: Advantages and disadvantages of different combinations of technologies.

Combination	Advantages	Disadvantages
Heat pump and PV	<ul style="list-style-type: none"> • Electricity source is traceable • Cheap operation, if net-metering is possible • Simple integration in net-metering situation • May decrease electricity grid congestion 	<ul style="list-style-type: none"> • Depends on the option for net-metering, i.e. only/mostly relevant if the electricity can be used in the heat pump directly • May lead to sub-optimization of the electricity production, in the overall electricity system.
Heat pump and boiler	<ul style="list-style-type: none"> • Increasing the capacity factor of the heat pump • Lowers the CAPEX per kW of the total system, compared to a system with a correspondingly large heat pump • Diversifies the energy input (fuel/electricity) and thus increases security of supply • The boiler may be used for regulation and peak loads to secure very stable operation of the heat pump, obtaining optimal operation of the heat pump 	<ul style="list-style-type: none"> • Necessitates a more sophisticated control strategy (most units are prepared for this)
Boiler and solar thermal	<ul style="list-style-type: none"> • The solar thermal collectors can cover hot water demand in the summer and parts of it in autumn and spring. The periods may vary by the geographic location. • Many manufacturers market this combination 	<ul style="list-style-type: none"> • A buffer tank is necessary for regulation in buildings with central hot water supply
Heat pump with (increased) storage	<ul style="list-style-type: none"> • More constant operation of the heat pump technically possible • Increases the possibility for "smart" operation (shiftable demand) • Pre-combined solutions are commercially available 	<ul style="list-style-type: none"> • Increased space demand for (increased) storage capacity • For smart grid application, a different operation and control strategy may be necessary

Combination	Advantages	Disadvantages
Heat pump and electric Boiler	<ul style="list-style-type: none"> • Electric boiler for temperature boosts and peak loads may make the operation of the heat pump more constant • Electric boilers for temperature boost and peak loads can lower the thermal capacity of the heat pump (lower CAPEX per kW of the total system) • Commercially available as an integrated combination/solution 	<ul style="list-style-type: none"> • Electric boilers have lower efficiency than heat pumps
Heat pump and solar thermal	<ul style="list-style-type: none"> • The solar thermal collectors can cover hot water demand in the summer and parts of it in autumn and spring. The periods may vary by the geographic location • Possibly increased SCOP, when the solar thermal collector may be used to regenerate a ground heat source or directly act as a heat source 	<ul style="list-style-type: none"> • Typically lack of synchronism between high thermal demands and availability of the solar thermal energy

1.3.6 District heating technologies

As a part of the combination of technologies, the possibility of local heating grids is presented. Since the heat producing technologies are the same as the large-scale technologies presented in Sections 1.3.1-1.3.4, the description is limited to the substations on building or apartment level and the heat distribution grid. The description is limited to the scale of the connection of a few buildings and does not include large-scale district heating technology that can supply entire cities.

1.4 Methodology – general

This section describes the applied methodologies regarding the data in the data sheet. Regarding cooling, data from Eco-labelling are available.

1.4.1 Building categories

The technologies included is categorised according to small-scale application (single-family building) and large-scale application (multi-family building and commercial building).

The technologies are typically available in ranges of size of capacity, and these ranges are described in the notes of each datasheet.

Applicability of a specific technology in a building depends on the size of the heat or cooling demand in the specific building. The applicability is determined by further analysis of the availability of specific sizes of capacities.

A key point regarding buildings and applicability of technologies is energy savings. The heating and cooling demand may be reduced by investing in e.g. insulation in the building. Please refer to section 3.10 regarding energy savings.

1.4.2 Efficiency

The data on efficiencies are from different sources. Where possible, the methodology is included in the notes for the specific technology. For most technologies, measured data is not available, in these cases the Ecodesign requirements apply, based on the assumption that these requirements are met for technologies available on the market.

Efficiencies for technologies varies significantly in part-load (in particular boilers) and according to the season (in particular heat pumps). Where possible these efficiencies are included for the specific technologies, but usually no measured data is available.

Therefore, in general Ecodesign requirements are assumed by default, unless otherwise stated.

1.4.3 Climate zones

Due to the amount of data collection, it is necessary to limit the data collection to a number of areas. For this, a number of representative areas is chosen, based on the climatic preconditions and the general price level across Europe. As for the climatic zones, the considerations by Ecofys et al.⁸ are used for inspiration. **Table 1-8** presents the climatic zones, as discussed by Ecofys et al.

Table 1-8: Five European zones based on global radiation, cooling degree-days, heating degree-days and cooling potential by night ventilation. (Ecofys et al., p. 149, Table 16)

	Cities
Zone 1	Athens – Larnaca – Luga – Catania – Seville – Palermo
Zone 2	Lisbon – Madrid – Marseille – Rome
Zone 3	Bratislava – Budapest – Ljubjana – Milan – Vienna
Zone 4	Amsterdam – Berlin – Brussels – Copenhagen – Dublin – London – Macon – Nancy – Paris – Prague – Warszawa
Zone 5	Helsinki – Riga – Stockholm – Gdansk – Tovarene

We choose these cities: Copenhagen (not Stockholm), Berlin, Lisbon, Catania, Budapest. Even though Copenhagen is in zone 4, we chose Copenhagen instead of Stockholm due to data availability. Seasonal efficiencies will be given for the relevant technologies (e.g. heat pumps) and for the identified geographical zones

Based on the above, the following countries/cities have been chosen for data collection regarding energy performance and installation & operation costs:

- Copenhagen / Denmark (rep. climatic zone 4/5)
- Berlin / Germany (rep. climatic zone 4)
- Budapest / Hungary (rep. climatic zone 3)
- Lisbon / Portugal (rep. climatic zone 1/2)

⁸ Ecofys et al. by order of The European Commission, 2013: Towards nearly zero-energy buildings - Definition of common principles under the EPBD

As can be seen from the chosen regions, Copenhagen and Lisbon correspondingly are chosen as cities that are within climatic zone 4 and 2 correspondingly. Being climatically very close to zones 5 and 1 correspondingly, these are thus assumed to be close to represent these zones too.

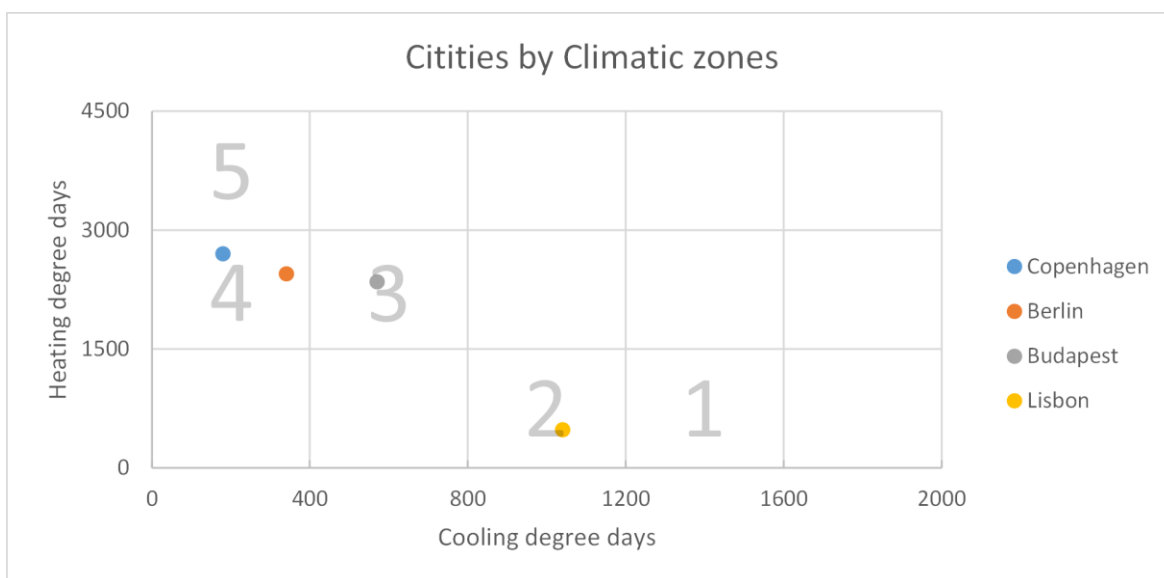

Figure 1-5: Climatic zones represented in the data gathering.

1.4.4 Technology readiness level

Technology Readiness Level (TRL) is a categorisation of technologies according to level of development or maturity of the technology, where a high level indicates a more mature technology.

The technology readiness level is assumed to be technology specific only, and not country specific. Hence, the same TRL-factor is applied for a specific technology in the different countries.

The TRL is also assumed to be the same for different sizes of capacity of the technology. Hence, the same TRL-level is applied for a specific technology with different sizes of capacity.

The definition of Technology Readiness Level, stated by the European Commission in the context of the Horizon 2020 project⁹, is applied in the report at hand. The European Commission defines the nine steps of technological readiness as in Table 1-9:

Table 1-9: *Technology Readiness Levels, based on EC.*

TRL 1	basic principles observed
TRL 2	technology concept formulated
TRL 3	experimental proof of concept
TRL 4	technology validated in lab
TRL 5	technology validated in relevant environment (industrially relevant environment in the case of key enabling technologies)
TRL 6	technology demonstrated in relevant environment (industrially relevant environment in the case of key enabling technologies)
TRL 7	system prototype demonstration in operational environment
TRL 8	system complete and qualified
TRL 9	actual system proven in operational environment (competitive manufacturing in the case of key enabling technologies; or in space)

1.4.5 Collection of Data and data quality

In the data collection process, a variety of sources is applied. When available, existing studies and/or comprehensive data sources like databases for the countries or regions under observation in this study are used as a baseline. The data in these studies is assessed to be of higher quality, than e.g. samples from suppliers. The data in these studies is then validated by crosschecking with information from suppliers, branch-statistics etc. A full overview over the used data sources is found under each technology datasheet. If no comprehensive overview or study is identified, data is based on samples from available suppliers of heating/cooling technology in the corresponding countries. A literature list for the qualitative description of technologies is presented in the end of this report. If a figure or text is not marked with a different reference, the Danish Energy Technology Catalogue¹⁰ is the reference.

In general, the data quality is relatively low, according to the definition of data quality, cf. the technical specifications for this study. However, high-quality sources of data have also been identified, in particular in Portugal and Germany.

A key point is the quality of collected data. Often, the data is based on a single source. There may be significant local variations within the same country due to different site-specific conditions or due to different suppliers or market conditions. In some cases, the technology is imported; hence, the price may reflect the pricing policy on different markets of the supplier. It is indicated wherever possible for each technology, whether there is a domestic supplier.

⁹ European Commission Decision C (2014) 4995 of 22 July 2014
https://ec.europa.eu/research/participants/portal/doc/call/h2020/common/1617621-part_19_general_annexes_v.2.0_en.pdf

¹⁰ Energinet.dk; Danish Energy Agency. Technology Data for Individual Heat Production and Energy Transport. Copenhagen: Energinet.dk, 2012.

The Danish data is from the Danish technology catalogue. Hence, the data and the sources are adopted to this catalogue.

A Portuguese-speaking partner has collected the Portuguese data. Key sources of information for Portugal include:

- Suppliers
- Database "DEKO", an independent organisation
- BOSCH has bought up all their sub-suppliers
- Websites and personal communication

A Hungarian-speaking partner has collected the Hungarian data. Mainly, the data is from a single source for each technology, typically from a supplier. Key sources of information for Hungary include:

- Suppliers
- Websites and personal communication

A German-speaking partner has collected the German data. Key sources of information for Germany include:

- A database (WEKA MEDIA, sirAdos) of appliance and installation costs for German buildings (typically used in the design and tender phase in German buildings)
- A study (BDEW), comparing installation and appliance costs for refurbishment in German building
- Price list from major supplier (Viessmann)

The sirAdos database is focused on planners, engineers and architects to estimate prices for services in the construction industry, mainly focusing on the domestic sector. It has also been applied in similar studies in order to estimate expected construction and installation prices in the German building industry. Prices are given according to VOB/C, a German clause for calculating prices in the construction industry. Amongst other requirements, the presented costs after VOB/C have to be supplier-neutral, i.e. presented costs and information regarding a given installation may not imply to represent product(s) from a certain manufacturer¹¹.

Prices are given as prices for a specific service, e.g. the installation costs of a ribbed radiator (of a chosen size per unit and quantity) estimated according to the sirAdos-database is excl. costs for other piping than the unit itself, which then would have to be added as an additional investment cost.

For the context of this report, information regarding the technical installations, especially heating installations, has been the main source. Costs for heating installations include an estimate for the installation costs and the unit price for the heating installation.

Costs for removal of an existing installation are not included, as this would depend on the given reference technology. Thus, it is assumed that the technical room where the new heating installation can be installed is prepared for the installation of a new heating unit (excl. grid connections and installations, mounting etc., which is included in the price for the given new technology).

¹¹ For niche technology, with only little variety of products on a given market, this is close to impossible to fulfil, but for more prevalent technologies, the prices are kept very "supplier-neutral".

Costs for heating installations according to the sirAdos database are calculated based on a method considering tender materials and input from planners, architects and alike, who have contributed to the database by sending information regarding settled costs from construction projects. Cost-estimates in the sirAdos-database are given in a span of low-mean-high, where the mean price represents a decent quality of the presented work and products. Hence, mean-prices have been applied in this catalogue.

1.4.6 Costs

Representing different cost levels, we choose: Germany, Portugal, Denmark, Hungary and UK, corresponding to the cities above according to the following table:

Table 1-10: Overview over climatic zones and corresponding cost levels applied.

City (climate)	Country (costs)	Comment
Copenhagen	Denmark	NE, Northern Europe
Paris	Germany, UK	CE, Central Europe
Lisbon	Portugal	SE, Southern Europe
Budapest	Hungary	EE, Eastern Europe

Cost data have been collected from these countries.

Data from Eurostat¹² is applied to interpolate to other countries with respect to main investment costs as well as main operation costs. The applied methodology will be described in detail.

Regarding installation costs, i.e. costs dependent on the hourly wages.

Key challenges regarding the costs include:

- different types of data sources – different data quality;
- significant site-specific variations – in some cases collection of data for costs of installation has been impossible, because the costs will vary from building to building with the site-specific conditions.

In the sections for each technology in chapter 2, data for the four countries Denmark, Portugal, Hungary and Germany is provided, in order to enable comparison of data. These tables are applied as part of the basis for elaborating interpolation to other countries.

1.4.7 Examples of interpolation of data

The selected countries of data collection represent different cost levels and different climate zones.

Based on the collected data for each technology, and by applying statistical information for e.g. labour costs, indication of values of key data in other countries can be derived.

Labour costs applied are “skilled labour” in the JRC-report on bioenergy potentials.¹³

¹² <http://ec.europa.eu/eurostat>

¹³ European Commission, Joint Research Center, 2015, *The JRC-EU-TIMES model- Bioenergy potentials for EU and neighbouring countries*, Annex 7 on labour costs
https://setis.ec.europa.eu/sites/default/files/reports/biomass_potentials_in_europe.pdf

E.g. for a gas boiler, the data for the four countries can be applied for estimating the costs in another country. The result should of course be verified with local data sources, but it gives an indication.

The methodology is:

1. Identify the country category of the country, according to the four categories
 - a. Northern Europe (Denmark)
 - b. Southern Europe (Portugal)
 - c. Eastern Europe (Hungary)
 - d. Central Europe (Germany)
2. Identify the labour costs for the specific technology
 - a. Calculate the factor $[\text{labour costs country } x] / [\text{labour costs country category}]$
 - b. Apply the factor to the "installation costs" share
3. Calculate the total costs
 - a. Add the price of the installation costs and the equipment costs from the country category.
4. Validate the result
 - a. Compare with data from the relevant country

1.5 Methodology – projections

A key focus in this catalogue is projection of data until 2050. These data are, however, based on assumptions and the methodology should therefore be considered. This section elaborates the methodologies applied for projection of data.

The collected data has included current data, and not expected future data, which was not available from the sources providing the current data. Hence, the first point is that the current and the projected data is based on different sources. This should be considered when studying the projected data.

For projection of data, the following steps are considered:

1. Danish references, applicability in other countries
2. TRL (technology readiness level) as indicator (elaborated below)
3. Other references (elaborated below)

The references provided in the datasheets typically apply to the current data. References for the projected data are typically the Danish catalogue and for heat pumps the indicated references.

1.5.1 Danish references for projections – applicability for other countries?

The Danish catalogue includes projections of key data, and this is included in the Danish datasheets. The quality and applicability of the references for the Danish data is assessed.

1.5.2 TRL as instrument for projection of data

One approach is to assume that projection of costs depends on the TRL (Technology Readiness Level). This implies that investment costs for mature technologies (TRL 9) in the future depend on the learning rates. Learning curves implies that for each

doubling of installations of a given technology, the costs would decrease by x %, as the installed capacity is doubled. The driver can be the technology itself, or it can be parts of the technology including e.g. development of costs of material e.g. steel. For less mature technologies, a development of the costs based on other parameters as well can be assumed. Hence, the methodology of learning curves is based on 1) rates of improvement based on technology-specific historical data and 2) market analyses.

This report does not comprise market data, and thus not learning rates. As an example, the number of heat pumps in UK has increased from almost none to more than 100 000 in 2013.¹⁴ The same reference provides information on the total heat pump capacity and number of installations per capita in 2012 in most EU-countries.

Market analyses and projections can contribute to the assessment of the development of specific technologies.

The solar thermal market in the European Union decreased by 8.6 % in 2015, continuing a decrease since 2009. This will imply that by 2020, the solar thermal production will be less than half the target set out in the NREAP¹⁵ roadmap, increasing the gap of one third in 2015.¹⁶ Hence, while anticipating an increase, the increase is less than foreseen in the political objectives for solar thermal.

In principle all technologies have a potential to improve technical efficiency as well as specific costs. The following technologies, of which some are TRL9, have a potential to improve.

- CHP-eng-micro-turbine
- CHP-eng-Stirling
- CHP-fc-gas
- CHP-fc-hydrogen
- Solar
 - A growing market – although not as fast growing as foreseen in the political targets for solar thermal. Increase in applications for district heating, which will have a positive influence on the individual applications (in focus in this catalogue).
- Storage
 - Storage becomes more relevant with higher share of fluctuating electricity and heat production. For individual or small scale applications, storage may also be more relevant, although

The projected data is included in the aggregated spreadsheet as well as main point in the report.

1.5.3 Heat pumps

Projection of data for heat pumps is included in the ETRI report.¹⁷ This reference provides data for some of the heat pumps.

¹⁴ European Heat Pump Market and Statistics Report, Nowak et al, 2014, figure from the paper "Raising the temperature of the UK heat pump market: Learning lessons from Finland", Matthew J. Hannon, Energy Policy, Volume 85, October 2015, Pages 369-375, <http://dx.doi.org/10.1016/j.enpol.2015.06.016>

¹⁵ National Renewable Energy Action Plans

¹⁶ Solar Thermal Barometer – EurObserv'er, May 2016, <http://www.eurobserv-er.org/solar-thermal-and-concentrated-solar-power-barometer-2016/>

¹⁷ European Commission, Joint Research Center, 2014, ETRI 2014 – Energy Technology Reference Indicator projections for 2010-50. https://setis.ec.europa.eu/system/files/ETRI_2014.pdf

A growing market implies more installations and thus basis for improvement due to competition among suppliers and increased number of installations.

Opposite to the solar thermal market, the development of the heat pump market is surpassing the NREAP targets in both 2015 and 2020. This regards renewable energy from heat pumps.¹⁸

The project "**SE**asonal **PE**formance factor and **MO**nitoring for heat pump systems in the building sector (SEPOMO-Build)" provides information on various applications of heat pumps.¹⁹ The project includes a best practice database.

The project "GROUND-MED" includes a database with best practice examples of ground source heat pumps. Of which most of them are applications in one-family houses.²⁰

These references, however, does not provide direct input to the projections of data for heat pumps, but rather serve to qualify the current information on heat pumps.

1.5.4 Updated Building Sector Appliance and Equipment Costs and Efficiencies, November 2016

The US energy administration has elaborated analyses and projections of buildings sector appliance and equipment costs and efficiencies.²¹ Appendix A of this reference provides projections until 2040 for most of the technologies included in this catalogue (oil, electrical, solar, gas, air conditioners, heat pump air source, gas heat pump, stoves, etc.).

A key point is that this reference regards the US market and thus not directly the European market, which is the scope of this catalogue. The reference is applied for supplementing the estimates for projections applied in this catalogue.

For gas boilers and gas heat pumps, the European market is highly influencing the price level in the US. Hence, this reference does not provide new information with regard to these technologies.

1.5.5 (HRE4) WP2, Fraunhofer EC report, Assessment of the technologies for the year 2012, March 2016

The Heatroadmap Europe project comprise mapping of energy resources and technologies.²²

1.5.6 EIA: Technology Roadmap, Energy-efficient Buildings: Heating and Cooling Equipment

The International Energy Agency has elaborated the report "Technology Roadmap – Energy-efficient buildings: Heating and Cooling equipment", which provides current as

¹⁸ Heat Pumps Barometer – EurObserv'er, 2016, <http://www.eurobserv-er.org/heat-pumps-barometer-2016/>

¹⁹ Homepage of the SEPOMO-project: <http://sepemo.ehpa.org/>. Accessed November 2016.

²⁰ Homepage of the GROUND-MED-project: <http://groundmed.eu/>. Accessed November 2016

²¹ U.S. Energy Information Agency (EIA) November 9th 2016, Updated Buildings Sector Appliance and Equipment Costs and Efficiency. <https://www.eia.gov/analysis/studies/buildings/equipcosts/> Accessed December 2016.

²² <https://ec.europa.eu/energy/sites/ener/files/documents/Report%20WP2.pdf>

well as projected costs (2030 and 2050) for a few technologies.²³ The estimates in this EIA report supplements the estimates of projections applied.

1.5.7 IEA, ETSAP, R02 Heating and cooling FINAL_GSOK

The IEA has elaborated estimates of current costs of several technologies. Comparison with the collected confirms the price levels, although there are significant variations.²⁴

IEA, ETSAP indicates 20 % reduction of heat pump costs by 2030.

1.5.8 Market Shares in Germany

There are two key references for future market share predictions: One scientific research project based on a discrete choice modelling, One by ITG Dresden, HWWI and BDH for Shell. BDH is a branch organization for existing heating installation manufacturers, HWWI is a rather independent and neutral research unit and ITG too (they are the main reference for the BDEW-input to datasheets).

EWI-report

The German Energy Economic Institute, University of Cologne, has published a study²⁵ on possible future market shares in the residential heat sector in Germany. A discrete choice modelling approach is chosen in the study, weighing factors like CAPEX, lifetime costs and comfort and environmental considerations by the user into account.

The study predicts an increase in the total volume of heating installations in Germany in the period 2015-30. Heat pumps (as a general category) will have increasing market shares (especially in new buildings), being expressed as an increase in sold appliances. The existing technologies (especially condensing oil boilers) are however expected to be the most sold technology until 2030.

Table 1-11: Sold appliances 2015-30. Based on Dieckhöner & Hecking, cf. footnote 25.

Sold appliances (1 000)	2015-20	2020-25	2025-30
Oil	1 800	1 600	1 500
Natural gas	500	350	300
Biomass	125	180	170
Heat pumps	360	620	750

1.5.9 Shell-BDH-report

The study presents a series of scenarios, one of them being a Trend-scenario. This scenario is based on current trends will continue in the near future and especially that consumers primarily stick to well-known energy carriers, like oil and gas. Hence, the

²³ EIA, 2011: *Technology Roadmap – Energy-efficient Buildings: Heating and Cooling Equipment*.
https://www.iea.org/publications/freepublications/publication/buildings_roadmap.pdf

²⁴ EIA, 2011: *Technology Roadmap – Energy-efficient Buildings: Heating and Cooling Equipment*.
https://www.iea.org/publications/freepublications/publication/buildings_roadmap.pdf

²⁵ Dieckhöner, C., Hecking, H., 2014, *Developments of the German Heat Market of Private Households until 2030: A Simulation Based Analysis*, Springer: Z. Energiewirtschaft, 38: 117-130

report by Shell, BDH, HHWI and iTG Dresden²⁶ predicts a more moderate increase in sold heat pumps and a slightly faster increase in biomass boilers, compared to the EWI-study. The differences in the expected sale volumes of natural gas and oil boilers forms a major difference between the two studies.

Table 1-12: Prediction of sold appliances in the Trend-scenario, Shell-BDH-report, cf. footnote 26.

Sold appliances (1 000)	2015-20	2020-30
Oil, condensing	750	2 400
Natural gas, condensing	1 300	1 150
Biomass	100	250
District Heating	50	50
Heat pumps	300	550
Micro CHP	-	-
Solar	750	1 500

1.6 Structure – sections for each technology

The structure applied for each technology is as follows (not all sections may apply for all technologies).

Description

- 1) Technical description
 - a) Brief description for non-engineers of how the technology works and for which purpose
- 2) Current use and possible evolution (including best available technology and research)
 - a) Cost reductions and improvements of performance. This section accounts for the assumptions underlying the improvements assumed in the datasheet.
 - b) A brief mentioning of recent technological innovations in full-scale commercial operation. With links, if possible.
 - c) The most important challenges from a research and development perspective
- 3) Conditions/restrictions related to the use of the technology (indication of required investments for application in all types of buildings)
 - a) This section provides information on relevant regulation for the technology. This includes EU-regulation, e.g. The 2010 Energy Performance of Buildings Directive, the 2012 Energy Efficiency Directive or the 2013 Regulation on Ecodesign requirements for space heaters and combination heaters

²⁶ Shell Deutschland, BDH, HHWI, iTG Dresden, 2013, *Shell BDH House heating study – Climate Mitigation in the Domestic Building Sector – How Will We Supply Heat Demands in the Future? – Facts, Trends and Perspectives for Heating Technologies towards 2030 (German title: Shell Hauswärme-Studie Klimaschutz im Wohnungssektor – Wie heizen wir morgen?)*. Shell Deutschland Oil GmbH, http://www.shell.de/promos/media/bdh-hauswarme-shell-studie/_jcr_content.stream/1455623261772/e8874e0ed5e3f0ef52c62a9ae674b5186d7b7bbd72351102fe0ff14f5c972a01/comms-shell-bdh-heating-study-2013.pdf

- (813/2013/EC). Supporting/elaborating national regulation is included, if relevant and available.
- b) Furthermore, considerations regarding the technical applicability of the given technology is mentioned. Factors like desirable forward temperatures, space demands and alike are therefore mentioned in this subsection. All presented technologies but wood stoves furthermore require an electric connection, which therefore is not mentioned for each technology individually.
- 4) Input and output (energy carriers)
 - a) The main raw materials, primarily fuels, consumed by the technology.
 - b) The forms of generated energy, i.e. electricity, heat etc.
 - 5) Typical capacities
 - a) The stated capacities are for a single unit.
 - b) Describing the range of available capacities and the typical applied capacities
 - c) Including indication of typical ranges of operation (0-100 % or 20-100 %) and e.g. weather dependence (e.g. solar radiation)
 - d) Capacities for electricity (production/consumption) and heating (production)
 - 6) Regulation ability (electricity)
 - a) Only for relevant technologies, i.e. which has direct possibility to contribute with regulation of electricity production or consumption (heat pumps, electrical heating, electricity producing technologies).
 - 7) Advantages and disadvantages
 - a) Listing the specific advantages and disadvantages relative to equivalent technologies. Generic advantages are ignored; e.g. renewable energy technologies mitigate climate risk and enhance security of supply
 - 8) Environmental considerations
 - a) Particular environmental characteristics are mentioned, e.g. special emissions or the main ecological footprints. Including Air pollution and e.g. leakage.
 - 9) Applications with combinations of other technologies
 - a) Overview and short description of typical combinations
 - 10) Indications of notable differences of techno-economic performance or applicability across Europe
 - a) Highlights of important points to note in the datasheet – a reader guidance.

Datasheet

Two versions of datasheets are provided – one for small-scale and one for large-scale applications. Both includes ranges of size of capacity. This will include relevant data for both existing and new buildings and the three types of buildings one-family house, multi-family house and office building.

Summarising datasheets are provided in the report, detailed datasheets are provided as separate spreadsheet-files.

The source of the data is provided wherever possible.

The data sheet contains basic data, rather than calculated data.

- 1) Energy/technical

- a) Production capacity for one unit, in a note the relevant product range is included
 - i) Capacity – a datasheet contains data for one capacity, relevant variations are included in the notes
 - ii) Heating and cooling capacity where relevant (heat pumps)
 - iii) Available capacities from suppliers.
 - iv) Two datasheets for each technology – one for small-scale application and one for large-scale application. Variations are indicated in the notes.
 - b) Expected share of space heating demand
 - c) Expected share of hot tap water demand
 - d) Total efficiency, annual average
 - i) Energy efficiencies will be based on the annual energy efficiency as defined in 813/2013/EC
 - ii) Net (%) are normally provided
 - iii) Efficiency in standard conditions to be provided where relevant (e.g. heat pumps)
 - iv) Differences according to ambient air temperature are included (8 °C in Denmark).
 - i) Regarding heat pumps, the temperatures of the relevant heat sources (e.g. ambient air, water or ground, or waste-heat from an industrial process) are specified.
 - ii) Part load efficiency, include when relevant in the notes
 - b) Cogeneration values (incl. efficiencies)
 - c) Technical lifetime
 - i) E.g. provide technical lifetime for each technology and costs for O&M.
- 2) Environment. Only direct emissions are included, not indirect (e.g. electricity for heat pumps) (cf. the ETRI-report). This implies that biomass will have emissions.
- a) SO₂ (g per GJ fuel)
 - b) NO_x (g per GJ fuel)
 - c) CH₄ (g per GJ fuel)
 - d) N₂O (g per GJ fuel)
 - e) CO₂ (g per GJ fuel)
 - f) Particles (g per GJ fuel)
 - i) Type of particles for each technology as it is technology/fuel specific
 - g) Other
- 3) Financial data
- a) Investment costs
 - i) Investment costs – EUR/unit, information on EUR/kW can be provided, by simply calculating for each example (total investment cost divided by the net generating capacity). No formulas are generated.

- ii) Financial data are all in Euro (EUR), fixed prices, price-level 2015 and exclude value added taxes (VAT) or other taxes.
 - iii) Investment costs consist of the two parts; equipment and installation. Installation costs may be based on statistics on costs of civil works.
 - iv) Economy of scale, examples (EUR/unit and EUR/kW) for specific sizes only, no formulas
 - v) Different organizations employ different systems of accounts to specify the elements of an investment cost estimate. As there is no universally employed nomenclature, investment costs do not always include the same items. Actually, most reference documents do not state the exact cost elements, thus introducing an unavoidable uncertainty that affects the validity of cost comparisons. In addition, many studies fail to report the year (price level) of a cost estimate. In this report, the intention is that investment cost shall include all physical equipment, typically called the engineering, procurement and construction (EPC) price or the overnight cost. Infrastructure or connection costs, i.e. electricity, fuel and water connections, are also included. The rent of land is not included but may be assessed based on the space requirements specified under the energy/technical data. The owners' predevelopment costs (administration, consultancy, project management, site preparation, approvals by authorities) and interest during construction are not included. The cost to dismantle decommissioned plants is also not included. Decommissioning costs may be offset by the residual value of the assets.
- a) Operation and maintenance costs
- i) Calculated from number of hours and cost levels of civil works in different countries (Eurostat). I.e. interpolation based on the statistics
 - ii) Fixed and variable part of O&M
 - iii) The fixed share of O&M (EUR/MW/year) includes all costs, which are independent of how the unit is operated, e.g. mandatory inspections, payments for O&M service agreements, network use of system charges, property tax, and insurance. No reinvestments for the expansion of the technical lifetime of a unit are included.
 - iv) The fixed part of O&M costs. A note regarding annual operation hours/outage, where relevant, can be added as a note under O&M (in addition to a short mentioning in the technical description).
 - v) The variable O&M costs (EUR/MWh) include consumption of auxiliary materials (water, lubricants, fuel additives), treatment and disposal of residuals, output related repair and maintenance, and spare parts (however not costs covered by guarantees and insurance).
 - vi) Fuel costs are not included. Own electricity consumption is included for heat only technologies, except for heat pumps.
 - vii) It should be noticed that O&M costs often develop over time. The stated O&M costs are therefore average costs during the entire lifetime.

Definitions

Specific terms used to describe the technology.

References

References for the qualitative description are in the sections for each technology.

Techno-economic projections until 2050 for smaller heating and cooling technologies in the residential and tertiary sector in the EU

The references for the quantitative description (the data sheet) are provided in each data sheet, which is included in each section for technology.

2 Technologies – descriptions and data sheets

This section contains descriptions of the specific technologies. This description comprises both a qualitative and a quantitative description. The quantitative description is provided in the form of datasheet. Overview tables are provided in the report, whereas detailed datasheets are provided in spreadsheet format. A number of data sheet is provided for each technology, representing data from different countries – when available data from Denmark, Portugal, Germany and Hungary are provided.

The data from the different countries in the datasheet shows some differences. The reasons for these differences can be different – and several might apply at the same time:

- The bottom-up approach applied in the data collection process implies differences due to only one or a few sources of information – the data quality can be relatively low in some cases
- A few applications of a technology imply that the costs for one installation are not representative. For some technologies, installation costs were not available from the suppliers.
- The suppliers’ pricing of a technology might depend on the pricing policy on a specific market (a specific country), most likely taking the local competition into account regarding other suppliers of the same technology and regarding substituting technologies. It is out of the scope of this report to include this factor. In many cases, the supplier of a specific technology is international, so this factor might be significant.
- Country-specific parameters are e.g. cost levels, which has been applied for the interpolation of costs. These are not necessarily sufficient to explain the differences

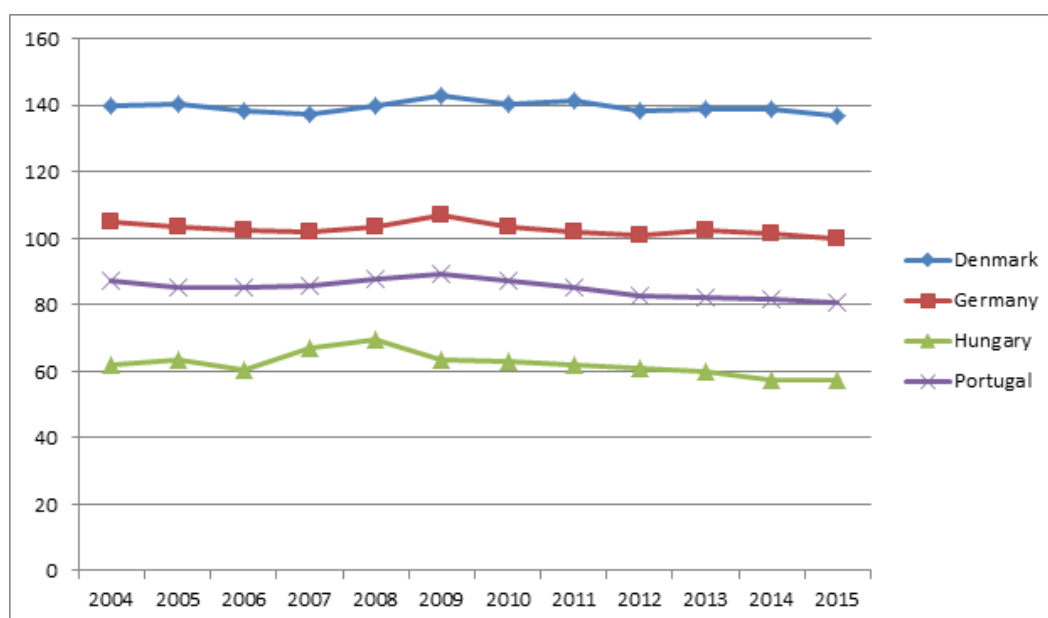

Figure 2-1: Comparable price data levels, incl. indirect taxes. ²⁷

²⁷ Based on Data from Eurostat, Dataset “Comparable Price Data Levels” Code tec00120, vers. 2.4.2-r2159-2016-08-11 (accessed November 2016)
<http://ec.europa.eu/eurostat/en/web/products-datasets/-/TEC00120>

As an example, the graph shows the comparative price levels of final consumption by private households including indirect taxes (EU average = 100).²⁸ This shows that the order of magnitude of this general parameter of price levels is significant, but in many cases not sufficient to explain the differences in costs for the technologies in the following sections.

2.1 Heat only boilers – oil boiler (condensation)

2.1.1 Technical description

Oil-fired boilers are made for hot water and steam production. In the following, only hot water boilers are considered. The boilers are made in a range from 15 kW to several MW. The oil qualities considered are:

1. Domestic mineral fuel oil.
2. Domestic oil with added bio-oil up to 10 % fatty acid methyl ester (FAME).
3. Raw bio oil, e.g. rapeseed oil.

The complete oil-fired system includes a boiler, a burner, an oil tank and a chimney or an exhaust system. In the case of a condensing boiler, a floor drain for the condensate should be available.

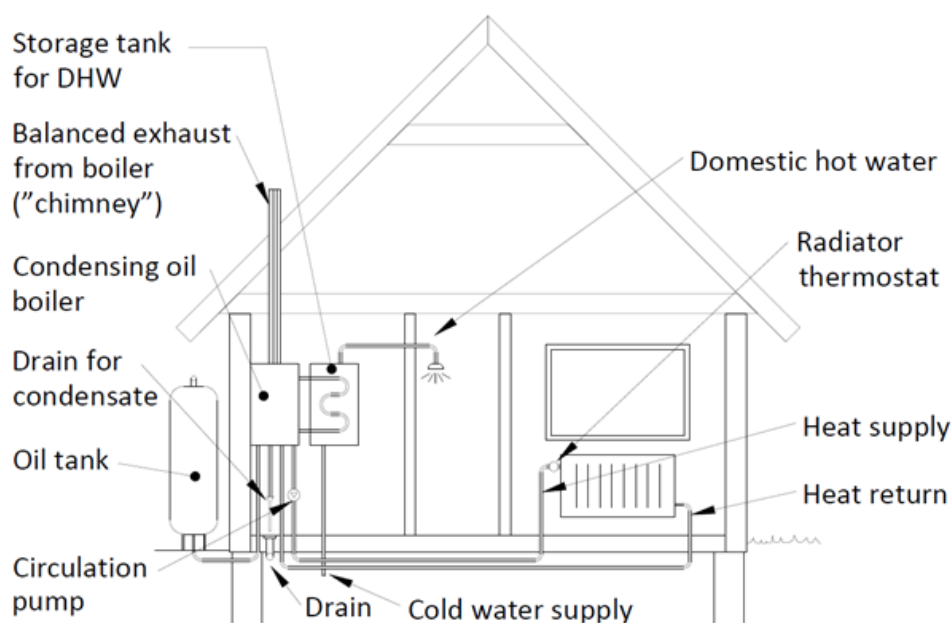

Figure 2-2: A typical installation of a condensing oil-fired boiler in a single-family house²⁹

The burner technology in smaller appliances is atomisation by a high-pressure oil nozzle for minor boilers. For very large boilers, other technologies are available, for instance atomisation by a rotating cup. Some advanced recently developed small boilers are also using some rotating cup technology, which allows for modulating burner control. The burners may be *yellow flame* burners giving a small emission of

²⁸ Based on Data from Eurostat, Dataset "Comparable Price Data Levels" Code tec00120, vers. 2.4.2-r2159-2016-08-11 (accessed November 2016)
<http://ec.europa.eu/eurostat/en/web/products-datasets/-/TEC00120>

²⁹ Energinet.dk; Danish Energy Agency. Technology Data for Individual Heat Production and Energy Transport. Copenhagen: Energinet.dk, 2013.

soot or *blue flame* burners without soot emission but with a tendency to emit CO instead of soot. For the different fuels, the burner technologies are somewhat different - e.g. some fuels require preheating of the oil.

Condensing oil boilers

Condensing oil boilers extract waste heat from the flue gasses, after the return water from the central heating system has cooled these in a first step. The waste heat is extracted by condensing the water content of the fuel that is evaporated in the combustion on a second heat exchanger (typically aluminium or other non-corrosive materials), very much like the condensing of flue gases in natural gas boilers. The condensate needs to be treated afterwards, e.g. by emitting it to the sewage or by treating them decentralised in case of very low pH/large amounts of condensate. The condensation can only happen when the return temperature of the central heating system is below the dew point of the flue gases (dependent on the fuel, typically around 55°C and less).

The boilers for all oil types are of almost similar design: a water-cooled combustion chamber and an integrated convection part. The materials are steel, cast iron or stainless steel. Modern boilers are delivered with a corrosion resistant flue gas cooler that allows for condensation of the water vapour in the flue gas.

Condensing oil-fired boilers can have efficiency in the range of 103 %³⁰ (of NCV) at full load and slightly less at partial load, if the return temperature from the heating system is sufficiently low, approximately 45°C, ref. 1, 2 and 3. Boilers can either be operated in on/off mode in combination with a hot water tank or in partial load.

2.1.2 Current use and possible evolution (including best available technology and research)

Research and development

The R&D in 60 years in combustion of mineral oil has resulted in very efficient, cheap and simple technology. Burner/boiler combinations with very small emissions and efficiency close to the thermodynamic limits are common standard on the market. Better burner/boiler combinations for the more difficult bio oils can be developed.

New types of bio oils are coming up, e.g., hydrotreated vegetable oil (HVO), cf. ref. 12. This type of oil can be produced in a quality very close to domestic mineral fuel oil. As for now, the combustion of bio-oil in small applications is concentrated around blends of conventional domestic fuel oil and up to 10 vol-% bio-oil, which most oil boilers are capable of combusting, without harming the fittings and other equipment. The combustion of 100 % bio-oil is very limited and concentrated locally around sources for bio-oil, as no overall market and supply system exists yet.

Examples of best available technology

The best modern boilers operate with annual efficiency in the range of 100 % (of NCV), dependent on the heating system to which the boiler is connected. At the same time, the boiler/burner can be chosen with very low emissions of pollution.

³⁰ Energinet.dk; Danish Energy Agency. Technology Data for Individual Heat Production and Energy Transport. Copenhagen: Energinet.dk, 2013.

2.1.3 Conditions/restrictions related to the use of the technology (indication of required investments for application in all types of buildings)

All new installed oil boilers have to meet the criteria in the EU-Regulation 813/2013/EU. Oil-fired boilers below 400 kW_{th} are regulated by the EU Ecodesign regulation (EC) 813/2013³¹ that set requirements for minimum energy efficiency and for NO_x.

The energy efficiency requirement is that seasonal energy efficiency calculated according to the regulation shall not be below 86% for boilers at or below 70 kW. Except for "B1" boilers (boilers with air intake from room intended to be connected to a natural draught chimney that evacuates the flue gas) with 10 kW (thermal) capacity or less, where efficiency must be 75 % or above. The regulation specifies a calculation method based on gross calorific value (GCV) and where the efficiency is reduced by accounting for temperature controls and electricity consumption as specified in Commission Communication in EU Official Journal (OJ) C 207, 3.7.2014, p. 2–21. For boilers above 70kW requirements are that the useful efficiency at 100 % of the rated heat output shall not fall below 86 %, and the useful efficiency at 30 % of the rated heat output shall not fall below 94 %. The regulation also requires that from September 26th 2018, NO_x emissions shall not exceed 120 mg/kWh fuel input in terms of GCV.

The same regulation also sets efficiency requirements for hot tap water production, if this function is included. The energy efficiency requirements depend on the size (tapping capability) of the water heating function.

Technical restrictions regarding the connected central heating system

Oil boilers can supply heat at all relevant temperatures and the technology is therefore technically applicable for most buildings. In order to condensate the flue gases, the return temperature of the central heating system must be below approximately 55°C.

Oil boilers require a chimney for exhaust gases.

It should be possible to place an oil tank in or close by the building. Furthermore, the building should be accessible by tank wagon, both in order for the fuel storage and – supply to be held in a comfortable way.

Examples of national regulation

The Danish Building Regulation (BR15) only allows the installation of oil-fired boilers, when the new boiler replaces an existing oil boiler and supply of natural gas or district heating is not possible for the building. Oil boilers are prohibited in new constructions.

In Denmark, the oil-fired boilers have to be inspected once a year for flue gas loss, soot and CO (for blue flame burners)

In Denmark, boilers with an input energy larger than 100 kW must fulfil "Luftvejledningen"³², which includes "OML" calculation of emissions (The pollution concentration in the landscape around the plant).

³¹ European Commission, Commission Regulation (EU) 813/2013 of 2 August 2013 implementing Directive 2009/125/EC of the European Parliament and of the Council with Regard to Ecodesign Requirements for Space Heaters and Combination Heaters, 2013. <http://eur-lex.europa.eu/LexUriServ/LexUriServ.do?uri=OJ:L:2013:239:0136:0161:EN:PDF>

³² Danish Environmental Agency (MST), The Handbook of Air(-quality) (Danish original title: *Luftvejledningen Begrænsning a luftforurening fra virksomheder*), 2001. <http://www2.mst.dk/udgiv/publikationer/2001/87-7944-625-6/pdf/87-7944-625-6.pdf>.

Similar or other regulation may apply in other countries.

2.1.4 Input and output (energy carriers)

Input

Domestic fuel oil is more or less the same as diesel. Bio oil (e.g. FAME³³) can be added up to approximately 10 % without severe problems. The results of higher shares of bio oil are e.g. soothing in the combustion chamber and blocking of the nozzle, due to differences in the fuel, compared to domestic fuel oil. Parts on existing boilers that are exposed to the fuel (and partly the flue gases) may have to be replaced (including fittings, nozzles etc.) if higher shares of bio-oil shall be combusted. Today, there are burners for pure bio oil on the market, i.e. existing boilers can be retrofitted to be fuelled by pure bio oil. The reliability and the maintenance (regular cleaning of the burner as an example) are not to be compared with burning of mineral oil ref. 10. Some research and development is needed, in case pure liquid bio fuels shall be used widespread. The problems mostly concern practical issues with components (rubber gaskets), storage, sensibility to ambient temperature variations, preheating of oil, electricity consumption of the burner etc. These are all problems that most probably can be solved.

For large plants - in MW size - burning of bio oil gives no problems. For domestic use, some of the above mentioned problems still remain.

Output

Heat for central heating and for hot tap water.

2.1.5 Typical capacities

The heat output range from 15 kW to several MW.

Small domestic boilers (15-100 kW)

The small boilers are used for domestic heating. The 15 kW boiler heats up to 200-300 m² of building area under Danish climate conditions. Very often, the boilers are built with an integrated hot water system, normally a tank of 80-150 l for hot tap water.

Larger boilers (100 kW - 1 MW)

These boilers are used in blocks of flats, institutions etc. and are constructed in steel or cast iron. If the connected heating system can deliver return temperatures below approximately 45°C, a condensing flue gas cooler will often be added. Units with integrated condensing flue gas cooler are also available, and in this case, application of stainless steel is required. The efficiency is given by the flue gas temperature - in best cases only few degrees higher than the return temperature. In large boilers, the heat loss from the boiler can be reduced to only a fraction of a percent (of NCV).

Regulation of heat output

The ability to reduce the heat output is excellent for most modern boilers. It should be emphasised that a boiler with a nominal heat output of 15 kW is able to operate at much lower heat output, many types down to almost zero heat output with a very high efficiency. The reason for this is that the heat loss from the boiler can be reduced by insulation and by low-temperature operation.

³³ Fatty Acid Methyl Esters

2.1.6 Regulation ability (electricity)

Only relevant for electricity-consuming or -producing technologies.

2.1.7 Advantages and disadvantages

The oil-fired boiler is a simple reliable technology, operating with a high thermal efficiency. The need for service is limited to once per year as stated in the regulations. In fact, one per two years will be sufficient for many installations. The disadvantages of domestic fuel oil boilers are related to the environmental considerations regarding the fuel.

2.1.8 Environmental considerations

A boiler fired with modern domestic fuel oil with very low content of sulphur and nitrogen will - except from the CO₂ - give very little pollution, almost corresponding to the pollution from natural gas. The pollution components are

- Unburnt hydrocarbon (only traces)
- CO (less than 100 ppm in the flue)
- NO_x (less than 110 mg/kWh ~ 30 g/GJ)
- Soot (Soot number 0 – 1), see Ref. 9.

2.1.9 Applications with combinations of other technologies

An oil boiler can be combined with e.g. heat pump, solar heating and wood stove. An oil boiler can serve as base load (in combination with wood stove) or peak load (in combination with heat pumps or solar heating).

2.1.10 Indications of notable differences of techno-economic performance or applicability across Europe

In the range of 250 000 oil-fired boilers are installed in Denmark, the largest part in single-family houses in areas where natural gas or district heating are not available. Usually, oil boilers are only applied when natural gas or district heating is not available, and thus not in combination with these technologies. Application of an oil boiler depends on the competitiveness of the oil boiler and regulation on applicable heating technologies.

The techno-economic performance of oil boilers is very stable across European Regions. The performance of oil boilers is slightly influenced by climatic factors like ambient temperature, as lower temperatures necessitate higher thermal supply effects, thus affecting the operation mode of the boiler. The annual heat efficiencies stated in the datasheet are based on the climatic characterizations of the chosen geographical locations.

Oil boilers are applicable in all areas considered for this report.

Table 2-1: Techno-economic data for oil boilers. More comments are given in the table below.

	2.1 HOB-oil	DK	PT	H	D
Small	Nominal heating/cooling capacity for one unit (kW)	30	23	30	30
	CAPEX (€/kW)	220	78	186	184
	CAPEX (€/unit)	6 600	1 800	5 566	5 527
	- hereof equipment (%)	70%	96%	98%	95%
	- hereof installation (%)	30%	4%	2%	5%
	Additional specific investment (€/unit)	-			3 350
	Fixed O&M (€/unit/year)	270	30	65	185
Variable O&M (€/GJ)	0				
Large	Nominal heating/cooling capacity for one unit (kW)	400	400	-	400
	CAPEX (€/kW)	80	83		68
	CAPEX (€/unit)	32 000	33 000		27 000
	- hereof equipment (%)	70%	70%		98%
	- hereof installation (%)	30%	30%		2%
	Additional specific investment (€/unit)				
	Fixed O&M (€/unit/year)	500	1 368		1 650
Variable O&M (€/GJ)					

DK	The minimum heat output for a pressure atomisation burner is in the range of 15 kW
PT	This is combi-fuel boiler - adapted for biomass and oil (EUR 444 for adapter). Baxiroca P30-4. Wo/ hot water store. This price includes oil burner and installation costs. No accumulation tank included. The capacity is relatively low. The low price is confirmed.
H	This type of application is already not popular in Hungary. Only one little Hungarian manufacturer can be found in the internet: http://morvaikazan.hu/olajtuzelesu-kazanok (more like a family business), however, when I asked about that boiler, they wanted to sell me a biomass-boiler instead of that. I also made a phone call with the Hungarian subsidiary of Wolf. The lady told me that this market does not exist in Hungary, there is no demand for oil boilers anymore. Besides of the boilers from the Hungarian producer, only second-hand oil boilers can be found on the Internet (Viessman, Hoval, Heizbösch: http://www.profikazan.hu/index.php?oldal=termekek&termek_kategoria=121005154100&alkategoria=121113212833), and in a limited scale (15-20 pieces). Chimney sweeping from 01.07.2016 is free of charge. Before that it was ~ 5 EUR, but there was a big territorial difference in point of the prize and the quality of the work. From that date the chimney sweeping will be done by a state-owned company. Yearly controlling is not compulsory No market for large-scale oil boilers in Hungary.

D	<p>A. Condensating domestic fuel oil boilers are available in nearly every capacity from few kW to MW-size. The burner can be step-by-step-modulating (2-3 steps) or stepless from approx. 30-50 % (of nominal) to nominal. Additional expenses cover the installation of a new oil tank, if necessary. The installation costs correspond with 6.5 person-hours for a skilled worker.</p> <p>For large appliances, installation costs correspond to approximately 12 person-hours (skilled worker). O&M costs include annual services of 11-12 person-hours + materials of approximately EUR 150. Additional investments cover a condensate neutralization system.</p> <p>Prices are primarily based on sirAdos www.baupreise.de, WEKA MEDIA GmbH & Co. KG</p>
----------	--

The low share for installation costs in Hungary applies when a heating system exists.

There are variations in the CAPEX and other parameters for the four countries. These are ascribed to the data quality (few data sources). The level of costs is confirmed by IEA, which has a cost of 135 and 90 EUR/kW for 20 kW and 120 kW units respectively, and a level of fixed O&M costs of 100 and 240 EUR/unit/year.³⁴

The costs applied in Heat Roadmap Europe seem to be on a higher level in general. This source does not expect any development of the parameters in the future, either.³⁵

Oil boilers are mature technology, no development of the parameters is expected.

2.1.11 Datasheet

Datasheets are provided for the countries Denmark, Portugal, Hungary and Germany. The detailed datasheets are available in Excel-format, including detailed notes and references. Please note that the data collection follows a bottom-up approach. Hence, data is presented as available and collected in the process of data collection. This is elaborated in the datasheets, when relevant.

Selected key data are provided in the tables above.

2.1.12 Definitions

Yellow flame

Low temperature combustion, resulting in an incomplete, sooty combustion.

Blue flame

High-temperature combustion, resulting in a cleaner and thus more efficient combustion.

Condensing boiler

A boiler that is capable of utilizing the energy in the evaporated water that was originally combusted as part of the fuel. In order for this to be possible, the return

³⁴ IEA Energy Technology Network, ETSAP – Energy Technology Systems Analysis Programme, Technology Brief June 2012, Table 1, page 9 in http://iea-etsap.org/E-TechDS/PDF/R02%20Heating%20and%20cooling%20FINAL_GSOK.pdf

³⁵ Fleiter et. Al, Mapping and Analyses f the Current and Future (2020-30) Heating/Cooling Fuel Deployment (Fossil/Renewable), Final Report for WP2, 2016. <https://ec.europa.eu/energy/sites/ener/files/documents/Report%20WP2.pdf>

temperature of the heating system must fall below the given dew point of the fuel, for domestic fuel oil approximately 48°C.

2.2 Heat only boilers – gas boiler (condensation)

2.2.1 Technical description

In a gas-fired boiler, gas is burnt in a combustion section. It may be a traditional flame or via specially designed low NO_x combustors. Heat is transferred to water through water-cooled walls and through a water tube heat exchanger after the combustion section. Gas boilers can be wall hung or floor standing.

The hot water from the gas boiler is circulated in the radiators of the house (a pump is therefore required on the installation or in the boiler).

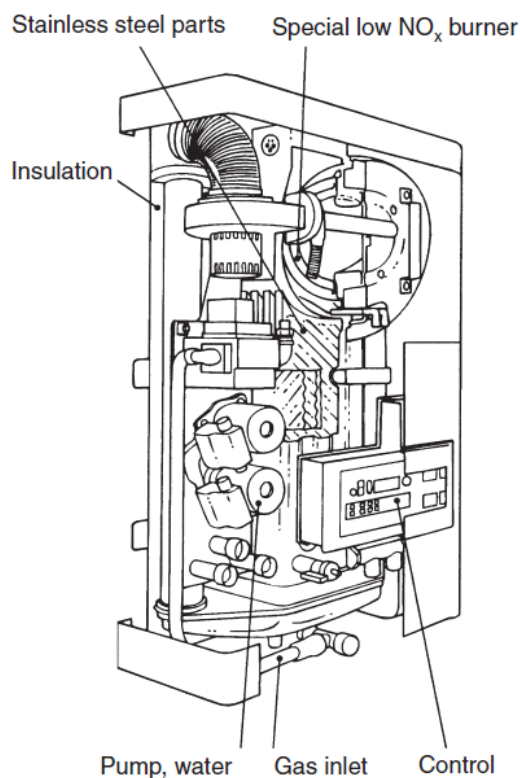

Figure 5.2: A wall hung gas boiler for single-family houses³⁶

A gas boiler is often called a "central heating (CH) boiler", as it is one of the elements of a central heating installation including boiler(s), a heat distribution system, heat emitters (radiators, convectors etc.) and a control system for the appliances. Of course, other heat production technologies, including other types of boilers, can also feed the central heating system.

Condensing Boilers

A condensing boiler is a boiler designed for low-temperature operation including recovering low-temperature heat and the latent heat from water vapour produced

³⁶ Energinet.dk; Danish Energy Agency. Technology Data for Individual Heat Production and Energy Transport. Copenhagen: Energinet.dk, 2013.

during the combustion of the fuel. Low-temperature operation is defined as temperature sets with a return temperature well below the dew point of the flue gases (for natural gas typically around 58 °C).

The condensing boilers include two stages of heat collection, compared to traditional boilers (non-condensing boilers), which only include one stage. In the condensing boiler, a second heat exchanger is placed before the flue gas exit to collect the latent heat contained in the flue. Most gas-fired boilers also allow for condensation in the combustion chamber.

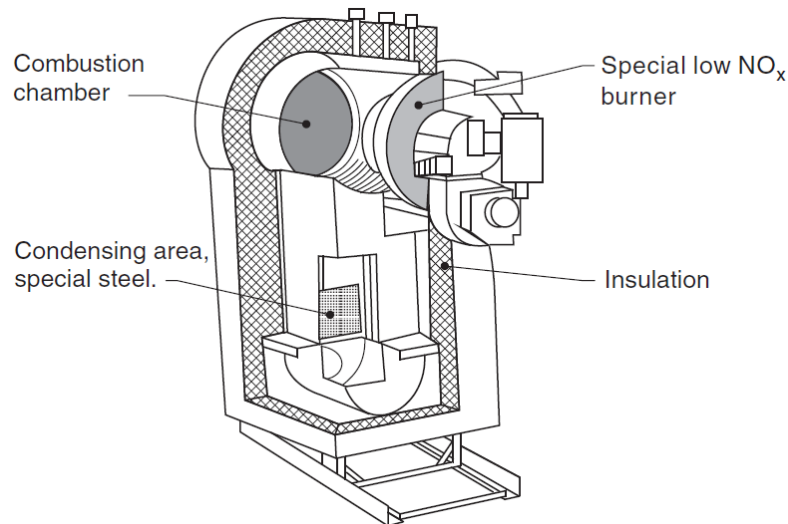

Figure 5.3: A floor standing medium size condensing gas boiler for apartment blocks etc.³⁷

Condensing flue gas recovery heat exchangers can be installed as auxiliary equipment after the boiler.

Gas combustion

In a gas boiler, the combustion often takes place by using specially designed burners for gas and the necessary combustion air. Most appliances will accommodate a large variety of natural gas compositions or LPG's with slight technical changes to the burner.

Use of gas boilers for heating and hot water production

Gas boilers are often used for heating and hot tap water production. Please see the section of house installations (section 3.10).

Condensing natural gas boilers can be applied either in combination with a hot water storage or for instantaneous hot water production (with the only "storage capacity" being the hot water system that the appliance is connected to).

Efficiency of gas boilers

Gas boilers' efficiency is mainly depending on water temperature. The newest condensing boilers on the market are often able to achieve more than 100 % efficiency (based on NCV). A Danish survey, based on actual consumption of 45 houses finds the annual energy efficiency of modern natural gas boilers to 101.9 %

³⁷ Energinet.dk; Danish Energy Agency. Technology Data for Individual Heat Production and Energy Transport. Copenhagen: Energinet.dk, 2013.

(NCV)³⁸ (based on maintenance reports from HMN (Danish NG-supplier) for condensing boilers in low-temperature systems. The improved insulation of boilers and new burner technologies make it possible to come close to the theoretically achievable efficiency. Efficiency in the range of 98-104 % as annual efficiency is now possible, suppliers indicate levels of 107-109 %, but the efficiency will also depend on the quality of the fuel.³⁹

Efficiency value depends on the content of hydrogen in the fuel, the higher the content of hydrogen in fuel, the higher is the content of H₂O in flue gases, which is then condensed in order to release the latent heat. Natural gas with high content of methane (CH₄) will enable higher efficiency than heating oil, which mainly consists of heavier hydrocarbon molecules where the share of hydrogen to carbon is lower. E.g. a 98 % value in technical specifications represents the efficiency based on upper heating value. This corresponds to 107-109 % efficiency based on calculation with lower heating value. For gas boilers, Vaillant reports 109 % for ecoVIT exclusive boilers (22-65 kW).

The Danish catalogue applies the methodology based on lower heating value. There is no international/European systematic comparison of calculated and actual/real efficiencies.

Annual efficiency referred to in the section "natural gas boilers" is calculated with BOILSIM, cf. the description in the Danish Technology Catalogue⁴⁰ and includes heating and hot water production based on Danish average houses.

2.2.2 Current use and possible evolution (including best available technology and research)

Research and development

R&D in the area is mainly dedicated to:

- low-NO_x burners;
- combustion controls enabling appliances to self-adapt to variations in gas composition.

Most natural gas-technology-related research is dedicated to the development of new technologies that may replace conventional gas boilers:

- domestic gas heat pumps;
- micro-CHP units

These new technologies are not covered by this technology description of gas boilers. Please see the respective sections.

Examples of best available technology

BAT in natural gas-fired boilers are modulating, condensing boilers with a range of 5 to 20 kW. The efficiency is constant over the range of modulation, and NO_x emission is

³⁸ Schweitzer, Jean, Frederiksen, Karsten og Jensen, Jan. Gasfyrede villakedlers virkningsgrad i praksis. Gasteknisk Tidsskrift. 2015, nr. 2.

³⁹ (DGC), Danish Gasteknological Institute. Test of more than 100 gas boilers in the DGC-laboratory. AND

Schweitzer, Jean og Christiansen, Christian Holm. Recent progress (and application) achieved in the way to estimate real performances of domestic boilers once installed. SAVE Workshop Utrecht. Utrecht: s.n., 2000.

⁴⁰ Energinet.dk; Danish Energy Agency. Technology Data for Individual Heat Production and Energy Transport. Copenhagen: Energinet.dk, 2013.

low due to the NO_x burner technology. Most of the condensing boilers on the market have now reached the highest achievable efficiency of 109-110 % of NCV (highest achievable with this technology) and can be considered to be BAT.

2.2.3 Conditions/restrictions related to the use of the technology (indication of required investments for application in all types of buildings)

All new installed gas boilers of 400 kW (thermal) or below have to meet the criteria in the EU-Ecodesign Regulation 813/2013/EU.

The energy efficiency requirement is the seasonal energy efficiency calculated according to the regulation, shall not be below 86 % for boilers with capacity of up to 70 kW. Except for "B1" boilers (boilers with air intake from room intended to be connected to a natural draught chimney that evacuates the flue gas) with 10 kW (thermal) capacity or less, in which case the minimum efficiency must be 75 %.

The regulation specifies a calculation method based on gross calorific value (GCV) and where the efficiency is reduced by accounting for temperature controls and electricity consumption as specified in Commission Communication in EU Official Journal (OJ) C 207, 3.7.2014, p. 2–21.

For boilers above 70 kW (and below 400 kW) requirements are that the useful efficiency at 100 % of the rated heat output shall not fall below 86 %, and the useful efficiency at 30 % of the rated heat output shall not fall below 94 %, also based on GCV. The regulation further requires that from September 26th 2018 NO_x emissions shall not exceed 56 mg/kWh fuel input in terms of GCV.

The same regulation also sets efficiency requirements for hot tap water production, if this function is included. The energy efficiency requirements depend on the size (tapping capability) of the water heating function.

Technical restrictions regarding the connected central heating system

Natural gas boilers can supply heat at all relevant temperatures and the technology is therefore technically applicable for most buildings. In order to condensate the flue gases, the return temperature of the central heating system must be below the dew point of the fuel. When condensating the flue gases, a drain for the condensate must be available.

Natural gas boilers require a chimney for exhaust gases.

It must be possible to connect to a natural gas distribution grid. The prevalence of natural gas grids varies across Europe and by the region. Alternatively, gas tanks are a technical solution, but rarely applied in small-scale residential purposes.

Examples of national regulation

The Danish Building Regulation (BR15) prohibits the installation of natural gas boilers in new constructions, unless no economically feasible alternatives can be found. Existing natural gas boilers may still be replaced. The EU-regulation (Ecodesign) implies only the requirements for a minimum efficiency of 86 % (higher value) for gas and oil.

2.2.4 Input and output (energy carriers)

Input

Natural gas boilers are using natural gas as fuel. They can also use LPG gases (in general with minor burner changes). Biogas can be used as well. It can be injected to the gas grid and mixed with natural gas (this requires major CO₂ removal from the gas to have a calorific value close to CH₄) or used directly.

Output

The form of energy generated by gas boilers is heat transferred to heated water. The output is hot water, either used for space heating or for hot tap water.

2.2.5 Typical capacities

For the domestic market, most of the gas boilers (single units) have a nominal heat output of about 20 kW and are modulating (see next section) down to 1 kW for very new technologies.

The 20 kW are needed to cover the *hot tap water production* (especially in the case of boilers without water tank), whereas for *heating* 10 kW or less would be sufficient for most of the domestic houses, with respect to climate variations and building insulation.

In general, gas boilers are produced as a series of similar appliances having different capacities. Examples of nominal capacities are 10, 20, 30 and 50 kW.

For apartment blocks and other large buildings, where the heat demand is larger than for single-family houses, larger boilers are used, but also the combination of several domestic appliances, connected in so-called "cascade" is a possible solution. In that case, the number of appliances in operation is determined by the heat demand.

The choice of heating technology is determined by factors like price and comfort. The choice can be made by the investor to connect to district heating or not, and if not, each apartment has its own gas boiler.

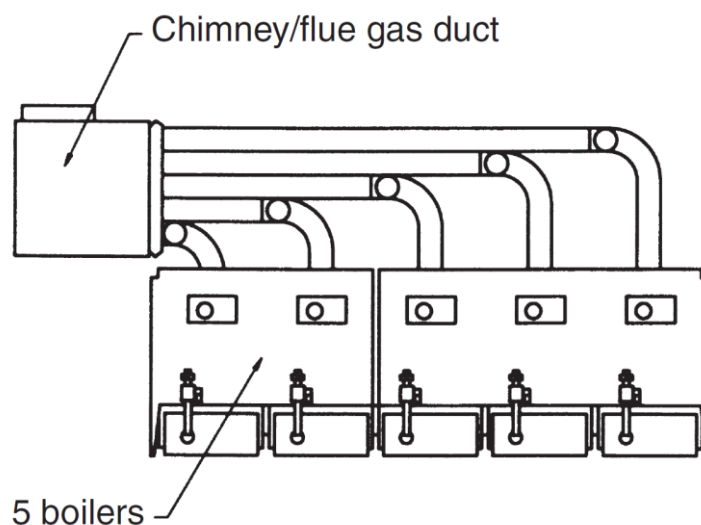

Figure 2-3: Cascade installation of boilers. ⁴¹

Regulation of heat output

Boilers are generally sold with controls that enable the optimal matching between the user demand and the heat production of the appliance. For example, in case the user needs hot water, the control system will give production priority to that demand. The control systems are able to communicate with components such as external temperature sensors or pumps. The control system will also adapt to other control elements such as radiator thermostats etc.

⁴¹ Energinet.dk; Danish Energy Agency. Technology Data for Individual Heat Production and Energy Transport. Copenhagen: Energinet.dk, 2012.

Control systems can be auto-adaptive: they will learn from the recent past to optimize the control of the boiler.

Most of the boilers on the present market are so-called "modulating" boilers. This feature allows the appliance to deliver reduced heat output without stopping the burner (the gas and airflows to the burner are reduced). Modulating ranges from 4 to 20 kW are typical, and technologies allowing very low minimum range are developed (starting from 1 kW). The modulation feature reduces the too frequent start-stop of the boiler and improves the user's comfort and the lifetime of the appliance.

Modern gas boilers have the possibility to program daily operation of the centralized heating system for a couple of time slots during the day and for each of the days in the week. The room temperature can be programmed differently for the time when people are in the house or at work and during the night. The same functionality can be applied to other technologies, including district heating, providing the same level of comfort.

2.2.6 Regulation ability (electricity)

Gas boilers have no regulation ability with regard to the electricity system.

2.2.7 Advantages and disadvantages

Advantages of gas boilers:

- Gas boilers offer an efficient way to use directly primary energy in homes. Modern condensing boilers have very small energy losses and are designed to cover the entire heat and hot water need of end users.
- CO₂- and NO_x-emissions of gas boilers are the lowest compared to any other fossil fuel boilers.
- The transport of natural gas to the houses through the gas grid is more energy efficient than the transport of oil.
- Opposite to district heating, there are no network losses related to the transportation of gas in the grid.
- Gas boilers provide high level of comfort and independency since the heating can practically be self-regulating, when installed correctly. However, the same functionality can be ascribed to other technologies, including district heating. This however, relates to a comprehensive discussion of advantages and disadvantages of individual technologies and collective technologies, which is out of scope for this catalogue.
- Modern gas boilers can be programmed to deliver heat according to needs of users during the day and differently for each day of the week.

Disadvantages of gas boilers:

- In the commercial sector, gas boilers are very competitive. However, in the domestic sector, the relative costs of central heating installations are getting very high, compared to the low energy need of modern and well insulated houses. Gas boilers are therefore decreasingly suitable for new small-size buildings or houses with low energy demand, compared to e.g. heat pumps possibly in combination with solar thermal. In practice, however, local conditions have great influence of the choice of technology.
- Price of natural gas is variable, implying sensitivity of the heat price dependent on the variations of price of natural gas.
- Security of supply may be an issue, in case the natural gas is imported.

2.2.8 Environmental considerations

Emissions

Gas boilers have low NO_x emissions (lower than oil boilers, due to the fuel), very little unburnt hydrocarbon (older burner technologies had some) and low CO-emissions.

Like other fossil fuel boilers, gas boilers have a net emission of CO₂.

2.2.9 Applications with combinations of other technologies

Hybrid systems and new technologies

Hybrid systems are mixing different technologies:

- Gas boilers can be used in combination with solar thermal energy, and dedicated and adapted products are available on the market⁴².
- Gas boilers can also be used in combination with electrical heat pumps [e] and provide heat when for example the electrical heat pump is not able to work efficiently (e.g. because of low external air temperature). Packages with electrical heat pumps and gas boilers are on the market already. The combination is quite attractive due to the good complementarity that can achieve high system efficiency.

2.2.10 Indications of notable differences of techno-economic performance or applicability across Europe

Table 2-2: Techno-economic data for gas boilers. More comments per country are given in the table below.

	2.2 HOB-gas	DK	PT	H	D
Small	Nominal heating/cooling capacity for one unit (kW)	20	24.4	18.5	30
	CAPEX (€/kW)	200	19	17	144
	CAPEX (€/unit)	4 000	465	320	4 309
	- hereof equipment (%)	45%	84%	50%	89%
	- hereof installation (%)	55%	16%	50%	11%
	Additional specific investment (€/unit)	2 000		1 054	1 700
	Fixed O&M (€/unit/year)	135	30	40	226
	Variable O&M (€/GJ)	100			
Large	Nominal heating/cooling capacity for one unit (kW)	750	400	300	400
	CAPEX (€/kW)	53	73	18	69
	CAPEX (€/unit)	40 000	29 000	5 400	27 420
	- hereof equipment (%)	85%	70%		98%
	- hereof installation (%)	15%	30%		2%
	Additional specific investment (€/unit)	2			8.6
	Fixed O&M (€/unit/year)	3 000	1 020		2 200
	Variable O&M (€/GJ)	2			

⁴² E.g. condensating boilers combined with a heat pump or solar heating. Please refer to the producers' webpages for this (e.g. Vaillant and Viessmann).

DK	Installation of a gas service line (grid connection). The price may change depending on the marketing of the gas distribution companies. For non-domestic appliances, the same price as for domestic is assumed. Only to be paid if the natural gas is not yet supplied to the house.
PT PT	<p>CAPEX: These shares are based on Buderus installers records. 30 % of the total price is the installation costs. O&M is annual and it represents 5 % of the costs of the equipment.</p> <p>Different data sources provide different prices. The low CAPEX for the small-scale capacities is confirmed.</p> <p>According to the other source, the relation between CAPEX for small-scale and large-scale is more logical. Reasons for this difference between the sources are not clear.</p>
H	<p>This is the most common-used heating equipment in households, there are more Hungarian producer.</p> <p>According to the 813/2013/EU regulation from 01.09.2015 only condensing boilers can be on sale. Shortly before that was a big boom of boilers-change, since the non-condensing are much cheaper.</p> <p>Chimney sweeping from 01.07.2016 is free of charge. Earlier it was about EUR 5, but there was a big territorial difference in point of the prize and the quality of the work. From that date the chimney sweeping will be done by a state-owned company. Base prize for the gas consumption is EUR 38. Yearly controlling price is around EUR 30-50 in case of a condensating gas boiler, depending on the circumstances.</p> <p>Annual controlling is not compulsory. However, there is a regulation from 2013, that all gas boilers have to be checked, according to the following timeframe:</p> <ul style="list-style-type: none"> • before the end of 2015, all gas boilers, installed before 1981 shall be controlled, • before the end of 2016, all gas boilers, installed before 1993 shall be controlled, • before the end of 2017, all gas boilers, installed between 1993 and 2004 shall be controlled and • before the end of 2018, the remaining gas boilers shall be controlled. <p>Costs for new installations: Connection to gas grid: EUR 100-160, price of the installation work: EUR 350, electrical installation fee: EUR 90, administration fee for gas bureau: EUR 23, gas pressure test: EUR 60-70.</p> <p>Total: EUR 700-800 (i.e. EUR 2.3-2.7/kW).</p> <p>Base prize for the gas consumption is EUR 38. Chimney sweeper: free of charge. Annual controlling price is around EUR 30-50 in case of a condensating gas boiler, depending on the circumstances.</p>
D	Installation: Approximately 12 person-hours for condensating units, incl. all mounting and installation and integration with central heating system. Additional expenses cover condensate neutralization system and connection to the natural gas grid, if none does exist.

The low CAPEX for Hungary is confirmed. There are boilers with higher price - for instance a Unical Modulex EXT 300 boiler is EUR 47.6/kW.

There are variations in the CAPEX and other parameters for the four countries. These are ascribed to the data quality (few data sources). The level of costs is confirmed by IEA, which has a cost of 125 and 80 EUR/kW for 20 kW and 120 kW units respectively, and a level of fixed O&M costs of 100 and 240 EUR/unit/year.⁴³

The costs applied in Heat Roadmap Europe seem to be on a higher level in general. This source does not expect any development of the parameters in the future, either.⁴⁴

Gas boilers are mature technology; reduction of CAPEX for large scale is expected.

2.2.11 Datasheet

Please refer to the detailed datasheet in the spreadsheet.

Please note that the data collection follows a bottom-up approach. Hence, data is presented as available and collected in the process of data collection. This is elaborated in the datasheets, when relevant.

2.3 Heat only boilers – biomass boiler

2.3.1 Technical description

Biomass boilers can be categorized based on the fuelling-mechanism and the fuel. The two very common boiler types are automatically stoking wood pellet boilers and manually stoking boilers using a variation of fuels, as these in many installations easily can replace an existing oil boiler without requiring other improvements (energy conservation, expansion of radiator capacity etc.). Typical fuels for manually stoking biomass boilers are wood pellets, briquettes, woodchips or logs (depending on the chosen stoking/burner technology).

A major difference between the two technologies is the comfort level for the consumer, as the manual stoking necessitates more work.

Another key difference is the cost of the storage, feeder etc., which is not expected to be feasible for small-capacity applications (15-25 kW). Hence, e.g. woodchips are usually only applied for capacities above 50 kW for automatically stoking boilers.

Automatically stoking boilers

Wood pellets are usually applied in automatically stoking biofuel boilers. However, some boilers, especially major ones, are also designed for firing with other types of biomass such as woodchips and grain.

The fuel is conveyed via an auger feeder from the fuel supply to the burner unit. In the burner, the combustion takes place during supply of primary and secondary air. The boiler is often a steel sheet boiler with a convection unit consisting of boiler tubes or plates.

The fuel can be supplied from an external storage tank located in the ground, a storage room or similar, or it can be supplied from an integral fuel hopper that is part of the boiler unit. Fuel is available in sacks and can be added to the silo manually, or -

⁴³ IEA Energy Technology Network, ETSAP – Energy Technology Systems Analysis Programme, Technology Brief June 2012, Table 1, page 9 in http://iea-etsap.org/E-TechDS/PDF/R02%20Heating%20and%20cooling%20FINAL_GSOK.pdf

⁴⁴ Fleiter et. Al, Mapping and Analyses f the Current and Future (2020-30) Heating/Cooling Fuel Deployment (Fossil/Renewable), Final Report for WP2, 2016. <https://ec.europa.eu/energy/sites/ener/files/documents/Report%20WP2.pdf>

in case of wood pellets - the fuel can be blown into the storage tank or room by a tanker.

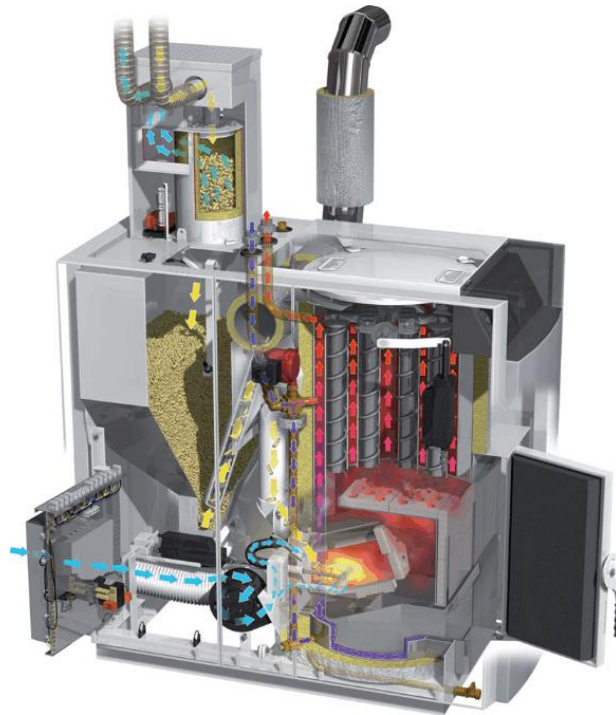

Figure 2-4: Biomass boiler, automatic stoking. The fuel tank (left in this illustration) may be installed differently, e.g. as a separate unit or in a separate room, according to the building and the necessary fuel load capacity (according to the intervals that the user wants to be able to be covered, without having to refuel).⁴⁵

Automatic biomass boilers are categorised in two types: compact plants consisting of a boiler and a burner in the same unit, and boilers with a detachable burner. Detachable burners can be approved up to 70 kW and are exclusively applicable for stoking with pellets.

All boilers can be regulated from less than 30 % to 100 % of full capacity, without violating emission requirements. The best technologies can be regulated from 10 to 120 % of the nominal heat output stated by the manufacturer on the boiler plate. The boiler regulates the load itself, according to the heat demand in the system it supplies with hot water. The daily maintenance by the owner is thus to empty the ash tray approximately once a week in cold periods and securing there is sufficient fuel in the storage.

Manually stoking boilers

Modern manually fired boilers for stoking with solid wood have downwards draught or down-draught. In downwards draught burners, the combustion air is led through a thin layer of fuel and led out on the backside of the combustion. The principle in a down draught burner is that the fuel is heated, dried and degasified in the combustion chamber, after which the gases are led downwards through a crevice in the bottom of the combustion chamber into the chamber where the combustion takes place during

⁴⁵ Energinet.dk; Danish Energy Agency. Technology Data for Individual Heat Production and Energy Transport. Copenhagen: Energinet.dk, 2012.

supply of secondary air. This type of boiler is typically provided with an air fan for supply of combustion air or a flue gas fan. Both combustion techniques can meet the current criteria. Downdraught boilers however achieve the highest fuel efficiency.



Figure 2-5: Double duty wood log boiler (manual stoking) prepared for mounting of pellet burner (automatic stoking)⁴⁶

Older types of boilers are updraught boilers and do not comply with the current environmental requirements.

Most manually stoking boilers are operated in on/off mode and the heat output can only be regulated in a few models, unless the user manages the fuel input closely. Thus, manual boilers should be (and are typically) installed with an accumulation tank of appropriate size to ensure an acceptable comfort level for the user. Heating can be carried out solely with a manual biomass boiler with a well-insulated accumulation tank. Despite an accumulation tank being installed, manual fired boilers demand more work by the users, as the fuel has to be stoking whenever there is a heat demand that exceeds the content of the accumulation tank in the given moment. Thus, manual fired boilers pose a less convenient solution than the automatic stoking ones. The work related to emptying the ash tray is comparable to the automatic stoking boilers and rather varying by the model than the technology as such.

2.3.2 Current use and possible evolution (including best available technology and research)

Research

There is still a need for R&D in the following areas:

- High-efficient and low-emission technologies
- Automation and comfort
- Fuel flexible, automatically stoking boilers
- Boilers with less than 5 kW nominal heat output.
- Condensing boilers using solid fuels.

⁴⁶ Energinet.dk; Danish Energy Agency. Technology Data for Individual Heat Production and Energy Transport. Copenhagen: Energinet.dk, 2012.

BAT

Irish boiler manufacturer Grant produces a wood pellet boiler that has a net efficiency at nominal load of 97 %.

Danish manufacturers of best available technology can be found on web lists at <http://www.teknologisk.dk/911>. The lists makes use of energy and emission labelling of the boilers. A similar list of appliances, available in UK, is presented at www.hetas.co.uk. "Grant" claims 95-97 % at up to 10 % water content in the pellets (common Danish quality around 6-8 % water content).

The best available technology according to EU Ecodesign regulation 2015/1189/EU has energy efficiency of 90 % (assuming condensing boiler) and air emissions at 10 % Oxygen in flue gas of:

- Particulate matter (PM) 2 mg / Nm³
- Organic gases (OGC) 1 mg / Nm³
- Carbon monoxide 6 mg / Nm³
- NO_x 97 mg / Nm³

2.3.3 Conditions/restrictions related to the use of the technology (indication of required investments for application in all types of buildings)

By January 1st 2020 new installed solid fuel boilers not exceeding 500 kW(thermal) have to meet the criteria in the EU-regulation 2015/1189/EU.

The energy efficiency requirement will be that seasonal energy efficiency calculated according to the regulation shall not be below 75 % for boilers at or below 20 kW and not be below 77 % for larger boilers The regulation specifies a calculation method using gross calorific value (GCV) and where the efficiency is reduced by accounting for temperature controls and electricity consumption.

The regulation also requires that from January 1st 2020 seasonal emissions to air shall not exceed the values in the below table, measures at concentrations in flue gas at 10 % Oxygen:

Table 2-3: Maximum values for emissions from (solid) biomass boilers from 2020, cf. EU-Regulation 2015/1189⁴⁷ *Value for biomass fuelled boilers, for solid fossil-fuelled boilers (mainly coal boilers) the limit is 350 mg/Nm³

Pollutant	Automatic stoking boilers	Manually stoking boilers
Particles (PM)	40 mg / Nm ³	60 mg/Nm ³
Organic gases (OGC)	20 mg/Nm ³	30 mg/Nm ³
Carbon monoxide	500 mg/Nm ³	700 mg/Nm ³
NO _x	200 mg/Nm ³ *	200 mg/Nm ³ *

2.3.4 Technical restrictions regarding the connected central heating system

Biomass boilers are technically applicable in most buildings, as the combustion is not sensitive to forward or return temperatures. It is possible to install the fuel storage for wood (pellet) boilers as bulk storage in a separate room. If chosen, the storage must

⁴⁷ European Commission, *Commission Regulation (EU) 2015/1189 of 28 April 2015 implementing Directive 2009/125/EC of the European Parliament and of the Council with Regard to Ecodesign Requirements for Solid Fuel Boilers, 2015.* <http://eur-lex.europa.eu/legal-content/EN/TXT/?uri=CELEX%3A32015R1189>

be accessible with a tube from the outside in order to supply the storage with fuel. Furthermore, a room close by the boiler will be occupied by the storage. Alternatively, outdoor tanks can be installed. Sacked pellets are a less space-requiring alternative, resulting in some work to refill the fuel buffer-storage.

Biomass boilers require a chimney for exhaust gases.

2.3.5 Input and output (energy carriers)

Input

Automatic stoking boilers use wood pellets or woodchips⁴⁸. Another possible fuel depending on the boiler type is non-woody biomass such as grain.

Manually stoking boilers typically use log wood, briquettes or woodchips. Multi-fuel burners make it possible to combust different solid biomasses such as the above mentioned.

The location of the fuel does not matter, the difference between manual and auto is only on the stoking, which is the same whether the fuel storage is integrated, next to the boiler or in a fuel storage room, as long as they are connected by a feeding system. Cf. figure 3.2 above.

Output

Heat for space heating and hot tap water.

2.3.6 Typical capacities

From 8 kW to 500 kW, or even larger. Detachable pellet burners from 8 kW to 70 kW.

2.3.7 Regulation ability (electricity)

Only relevant for electricity-consuming technologies.

2.3.8 Advantages and disadvantages

Advantages

The investment in a new biomass boiler is often limited, if an existing oil burner must be replaced anyway.

Disadvantage

Biomass boilers and storage capacities require room space and an appropriate boiler room. For larger boilers, and also in case of firing with other types of fuels than pellets, the labour needed for maintenance must be considered. All biomass boilers require a moderate level of maintenance work in relation to the cleaning of the ashtray.

2.3.9 Environmental considerations

Use of high fuel quality and advanced technological combustion concepts ensure that automatic combustion systems are environmentally sound and efficient residential

⁴⁸ Wood pellets are small, compressed pellets made of e.g. wood shavings and sanding dust compressed under high pressure and with maximum 1 % binding agents. Wood pellets have typically a diameter of 6 mm or 8 mm and a moisture content of about 6-8 %. The length varies up to 5 times the diameter.

Woodchips consist of wood pieces of 5-50 mm in the fibre direction, longer twigs (slivers), and a fine fraction (fines). There exist three types of woodchips: Fine, coarse and extra coarse. The names refer to the size distribution only, and not to the quality.

heating technologies. The legislation requirements are easy to meet for the best available technologies firing with wood pellets and woodchips.

For manual stoking boilers, examinations show that newer boilers with accumulation tank cause considerably less pollution compared to old updraught boilers, due to a cleaner combustion.

2.3.10 Applications with combinations of other technologies

Heating can be done solely with an automatic biofuel boiler, but hybrid systems like solar/biomass or others are attractive to combine solar thermal technologies in summer for hot tap water, while biomass is turned off and remains the main heat source for hot tap water and space heating during the rest of the year.

Many biomass boilers are installed in combination with a continuous flow-water heater for periods of low to none heating demand and only hot tap water demand.

2.3.11 Indications of notable differences of techno-economic performance or applicability across Europe

Table 2-4: Techno-economic data for biomass boilers. More comments per country are given in the table below.

	2.3 HOB-biomass	DK	PT	H	D
Small	Nominal heating/cooling capacity for one unit	20	7	23	35
	CAPEX (€/kW)	550	200	24	371
	CAPEX (€/unit)	11 000	1 399	556	13 000
	- hereof equipment (%)	90%	86%	91%	95%
	- hereof installation (%)	10%	14%	9%	5%
	Additional specific investment (€/unit)	1 600	81	185	2 600
	Fixed O&M (€/unit/year)	40	60	50	471
	Variable O&M (€/GJ)				
Large	Nominal heating/cooling capacity for one unit	1 000	400	300	200
	CAPEX (€/kW)	170	217	132	192
	CAPEX (€/unit)	170 000	86 900	39 450	38 300
	- hereof equipment (%)		70%	100%	95%
	- hereof installation (%)		30%	0%	5%
	Additional specific investment (€/unit)	5-25	1278		4500
	Fixed O&M (€/unit/year)	6 300	3 040		500
	Variable O&M (€/GJ)				
DK	Prerequisite: house with central heating system. Large variation in CAPEX, mainly due to different finish, design etc. but to some extent also due to size/capacity.				
PT	Small: CAPEX: EUR 1199 (ref. 2)+ installation Additional investment only includes the pipes. Large: These shares are based on Burerus installers records. 30 % of the total price is the installation costs. O&M is annual and it represents 5 % of the costs of the equipment.				

<p>H</p>	<p>This type of boiler is the most popular after the natural gas boiler, however within the biomass boilers the most popular subcategory is the co-fired boiler.</p> <p>Installation cost: for a normal wood or a pellet boiler is around EUR 50 (EUR 2.1/kW), for a wood-chip boiler EUR 75 (EUR 3.2/kW)- see Ref 5.</p> <p>Accumulation tank: 500 l – EUR 185, 750 l – EUR 222 - see Ref. 4.</p> <p>Large: There is no Hungarian producer in this scale (the biggest Hungarian product is 90 kW).</p> <p>Installation cost: for a normal wood or a pellet boiler is around EUR 150 (EUR 0.5/kW), for a wood-chip boiler EUR 230 (EUR 0.8/kW).</p> <p>For large scale, the price of the installation work is typically 30 %, the additional appliances 50 % higher than in the case of the smaller boilers.</p> <p>For Hungary, an even lower price – EUR 17/kW - http://www.arukereso.hu/kazan-kalyha-c4026/hoterm/carbon-m-23-p44592454/. Another Hungarian production, the price is almost the same: http://netkazan.hu/termek/811/totya-s23-lemesz-vegyestuzelesu-kazan. However, a wood gasification boiler is 45 EUR/kW - (http://netkazan.hu/termek/2928/attack-dp-25-s-standard-25-kw-os-faelgazosito-kazan) - 25 kW). No wood gasification boiler from Hungarian manufacture.</p> <p>The higher price for large scale for Hungary: the EUR/kW value is much higher because they have built-in automatic operator system and other parts which a smaller biomass boiler does not have (see the technical features of the 300 Kw Italian boiler: http://www.caldaiedalessandro.it/ita/index.php?option=com_content&view=article&id=33&Itemid=11&lang=en)</p>
<p>D</p>	<p>Includes the boiler, fuel feeding system, short-time on-site fuel storage (i.e. excl. expenses for the room that is occupied by the long-term fuel storage) and installation. Excl. hot water storage. Additional expenses include the installation of a pellet transport system, increasing the comfort level for the consumer. O&M cover the annual cleansing by a chimney sweeper and maintenance and service of the burner and boiler.</p> <p>Data for large appliances regard manual stoking burners</p>

There are variations in the CAPEX and other parameters for the four countries. These are ascribed to the data quality (few data sources). The level of costs is confirmed by IEA, which has a cost of 596 and 375 EUR/kW for 20 kW and 120 kW units respectively, and a level of fixed O&M costs of 260 and 1 200 EUR/unit/year.⁴⁹

Biomass boilers are mature technology, some development of the parameters is expected. An increase of CAPEX for small capacities is expected.

⁴⁹ IEA Energy Technology Network, ETSAP – Energy Technology Systems Analysis Programme, Technology Brief June 2012, Table 1, page 9 in http://iea-etsap.org/E-TechDS/PDF/R02%20Heating%20and%20cooling%20FINAL_GSOK.pdf

2.3.12 Datasheet

Please refer to the detailed datasheets in the spreadsheet at <http://data.europa.eu/89h/jrc-etri-techno-economics-smaller-heating-cooling-technologies-2017>

2.4 Heat only – wood stove

2.4.1 Technical description

A wood stove is an enclosed room heater used to heat the space in which the stove is situated.

Usually, the wood stove is fired with a batch of 2-3 pieces of new firewood at a time. The firing takes place when there are no more visible yellow flames from the previous basic fire bed, and when a suitable layer of embers has been created.

Modern wood stoves have up to three air inlet systems in order to achieve the best possible combustion and to ensure that the glass pane in the front door does not get sooty:

- primary air up through the bottom of the combustion chamber,
- secondary air as air wash to keep the combustion alive and to maintain the glass clean, and
- tertiary air in the backside of the combustion chamber for after-burning of the gases.



Figure 2-6: Wood stove⁵⁰

Some stoves need to have the air inlet dampers manually adjusted in connection with each new fired batch (maximum 3-5 minutes after each charge); others are more or less self-regulating.

⁵⁰ Energinet.dk; Danish Energy Agency. Technology Data for Individual Heat Production and Energy Transport. Copenhagen: Energinet.dk, 2012.

The chimney serves as the motor of the stove, and is essential to the functioning. The chimney draught sucks air through the air dampers to the combustion chamber.

Heat from wood stove is usually a supplement to other kinds of heat supply.

By regulating the air dampers, the heating capacity of the stove can be minimized or maximized within a few kW, however, this might e.g. result in an increased emission.

2.4.2 Current use and possible evolution (including best available technology and research)

Research and development

There is a need for continuous development of stoves with the purpose of reducing the particle emissions and decreasing the supply to low-energy houses.

Examples of best available technology

Some Danish manufacturers produce swan-labelled⁵¹ products, which can be found on the web lists at <http://www.ecolabel.dk>. The swan label is a voluntary agreement, and labelled stoves must comply with extra stringent emission requirements.

According to EU Ecodesign regulation the best available technology has a seasonal efficiency of 94 % for wood pellet fired ovens and 86% for other ovens, calculated with gross calorific value (GCV) and emissions as follows (given in concentrations in flue gas at 13 % Oxygenee):

- Particulate matters: 20 mg / Nm³ (wood pellet fired 10 mg / Nm³)
- Organic gases (OGC): 30 mg / Nm³ (wood pellet fired 10 mg / Nm³)
- Carbon monoxide: 500 mg / Nm³ (wood pellet fired 250 mg / Nm³)
- NOx: 50 mg / Nm³

(the benchmarks does not imply that a combination of these values are achievable in a single oven.)

The current BAT is characterized by emissions in the range 2-3 g/kg, whereas the Ecodesign regulation will require emissions of not more than 5 g/kg from 2022.

2.4.3 Conditions/restrictions related to the use of the technology (indication of required investments for application in all types of buildings)

By January 1st 2022 new installed solid fuel ovens (local space heaters) not exceeding 50 kW_{th} have to meet the criteria in the EU-Regulation 2015/1185/EU.

The energy efficiency requirement will be that seasonal energy efficiency calculated according to the regulation shall not be below 30 % for open heaters and not below 65% for closed heaters, while for heaters fired with wood pellets (of compressed wood) shall not be below 75 %. The regulation specifies a calculation method using gross calorific value (GCV).

The regulation also requires that from January 1st 2022 seasonal emissions to air shall not exceed the values in the table below, measured as concentrations in flue gas at 13 % Oxygen:

⁵¹ Environmental label for products in the Nordic Region.

Table 2-5: Maximum values for emissions of solid fuel local space heaters, fired with biomass, cf. EU-Regulation 2015/1185⁵² *for solid fossil fuel fired heaters the limit is 300 mg/Nm³

Pollutant	General heaters	Pellet fired heaters
Particles (PM)	50 mg / Nm ³ Open fronted heaters 40 mg/Nm ³ (closed heaters)	20 mg/Nm ³
Organic gases (OGC)	120 mgC/Nm ³	60 mgC/Nm ³
Carbon monoxide	1500 mg/Nm ³	300 mg/Nm ³
NOx	200 mg/Nm ³ *	200 mg/Nm ³

Technical restrictions regarding the connected central heating system

Wood stoves require a chimney for exhaust gases.

Examples of national regulation

The above described requirements of the Nordic Eco label (Svanemærket) have stepwise been made national regulation in i.e. Denmark.

2.4.4 Input and output (energy carriers)

Input

Wood logs of different sorts like beech, birch and pinewood, or any other type of wood. The humidity should be of 12 to 20 %, and the size of the wood logs depends on the stove but usually about 250 to 330 mm with a weight of 700 to 1000 g.

Output

Space heating by convection and radiation.

2.4.5 Typical capacities

Typical capacities are 4 to 8 kW nominal output. The heat output is regulated by regulation of the air intake and the supply of fuel.

2.4.6 Regulation ability (electricity)

Only relevant for electricity-consuming technology.

2.4.7 Advantages and disadvantages

The potential local particle pollution poses a disadvantage of wood stoves. The best available technology limits the local pollution considerably, down to approximately 2-

⁵² European Commission, Commission Regulation (EU) 2015/1185 of 24 April 2015 implementing Directive 2009/125/EC of the European Parliament and of the Council with Regard to Ecodesign Requirements for Solid Fuel Local Space Heaters, 2015. <http://eur-lex.europa.eu/legal-content/EN/TXT/?uri=CELEX%3A32015R118>

3 g/kg; however, local pollution remains a possibility, due to operation issues in terms of using other fuels than clean logs or wrong regulation of the combustion.

2.4.8 Environmental considerations

In practice, pollution from wood stoking in stoves is a correlation between a series of factors such as stoking conduct, the individual stove and chimney in relation to the surroundings. A Danish study⁵³ shows that the PM_{2,5}-concentration in a residential area with many wood stoves (and solid biomass fuelled boilers) equals the PM_{2,5}-concentration at a highly trafficked road, resulting in possible healthcare issues for the population in the area.

Newer swan-labelled (environmental certification system in the Nordic Region) stoves comply with the more rigorous requirements for particles according to the current legislation.

2.4.9 Applications with combinations of other technologies

Wood stoves are usually used as a supplementary heating source on single-room level and must thus be installed in combination with other technologies such as a central heating system, in order to meet the heating demand. As most wood stoves only supply space heating, hot tap water demand must be met by other technologies too.

Some stoves are assembled with a water tank, and thus they can be connected to the central heating system. In some rural areas of Europe, stoves are applied primarily for cooking purposes and heating is just a by-product in that case.

2.4.10 Indications of notable differences of techno-economic performance or applicability across Europe

Table 2-6: Techno-economic data for wood boilers. Comments on these data are provided in the table below.

	2.4 HOB-wood	DK	PT	H	D
Small	Nominal heating/cooling capacity for one unit (kW)	12	11	5.5	
	CAPEX (€/kW)	217	150	33	
	CAPEX (€/unit)	2 600	1 650	182	
	- hereof equipment (%)	77%	85%	55%	
	- hereof installation (%)	23%	15%	45%	
	Additional specific investment (€/unit)	1 600			
	Fixed O&M (€/unit/year)	1.2	60	0	
	Variable O&M (€/GJ)				

DK	The share of space heating covered by a wood stove depends on the possibility to regularly charge the stove with wood logs and of the location of the stove in the house. With regularly charging and a central location of the stove, the coverage can be up to 80 % of the heating demand in the house. Approximately 10 % larger is possible for stoves with a water tank. Taking into consideration that normally the average residents will have difficulties with regular fuel charging, the expected share of space heating covered by
-----------	---

⁵³ Nielsen, Elsa, Dybdahl, Marianne og Larsen, Poul Bo. Health effects assessment of exposure to particles from wood smoke. Copenhagen: Danish Ministry of Environment, 2008.

	the wood stove without a water tank will be in the range of 20 % to 60 %. A large coverage requires that doors between the room where wood stove is placed and the adjoining rooms are open or an air circulation system is installed.
PT	Pellets, prices from one supplier and the independent database "DECO"
H	There is only one Hungarian wood stove producer. A bigger wood stove with 16 kW capacity is EUR 380 (EUR 24/kW). Two versions; wood stove and wood stove with thermos circle.
D	

An increase of CAPEX is expected due to increased automation in stoves. A higher share of installation costs, compared to equipment costs.

2.4.11 Datasheet

Please refer to the detailed datasheets in the spreadsheet at <http://data.europa.eu/89h/jrc-etri-techno-economics-smaller-heating-cooling-technologies-2017>

2.5 Heat pumps, electrical – air to air

2.5.1 Technical description

For a general introduction to heat pumps, please refer to section 1.2.3.

Air-to-air heat pumps draw heat from ambient air and supply heat locally through air heat exchangers. Most air-to-air heat pumps have one outdoor unit and one indoor unit and are often referred to as "split-units". This configuration means that the heat pump can only supply heat to where the indoor unit is placed.

Air-to-air heat pumps with more than one indoor heat exchanger (multi-split units) are also available, but they are only representing a very small percentage of the installed air-to-air heat pumps today.

Many air-to-air heat pumps are reversible so that they can be used for cooling in warm periods (air-condition).

A single air-to-air heat pump normally covers between 60 % and 80 %⁵⁴ of the total space heating demand of a building, when applying it as the primary heating installation in a main room, with decentralized heating units in the other rooms (as illustrated in **Figure2-7**). A large coverage requires that the doors between the room where the air-to-air heat pump is placed and the adjoining rooms are open or an air circulation system is installed. The remaining space heating demand must be covered by other sources, which would normally be electrical heaters or additional air-to-air heat pumps. Air-to-air heat pumps can be a very good supplementary investments in buildings with electrical heating.

Heat pump efficiency in general depends on the temperatures on the cold (outdoor) and the warm (indoor) side of the heat pump. Lower temperatures on the cold side as well as higher temperatures on the warm side decrease the efficiency. The heat demand is normally higher when outdoor temperatures are low. Therefore, it is

⁵⁴ Air-to-air heat pumps can also be applied as the only heat source in separated rooms, thus covering 100 % of the room.

important to compare the average yearly efficiency (SCOP) instead of the efficiency at a single working point.

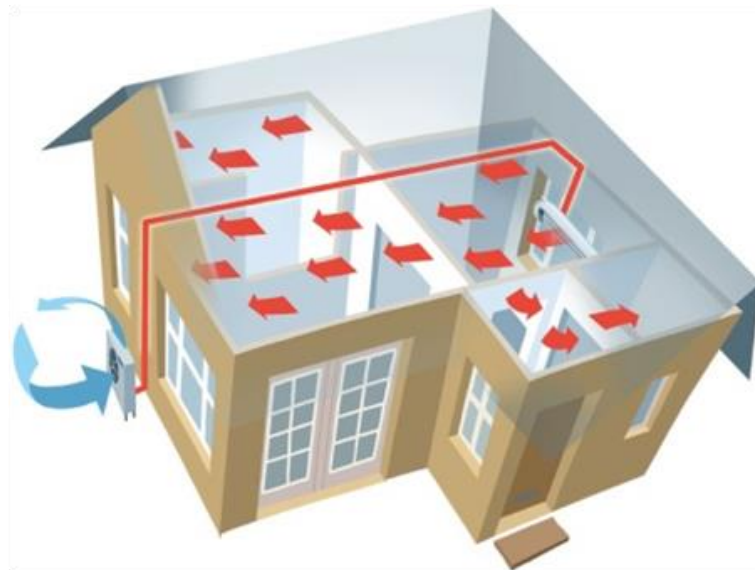

Figure2-7: Electrical heat pump, air-to-air⁵⁵

Different types of regulation exist for this type of heat pumps. There is on/off regulation and capacity regulation, which is continuously variable down to about 20 % of the maximum capacity.

Capacity regulation works through a variable speed compressor where the amount of refrigerant flow through the refrigerant cycle is adapted to the demand. In on/off regulation, the compressor will work full load and stop at intervals adapted to the heat demand.

The main part of air-to-air heat pumps in the market today has capacity regulation.

2.5.2 Current use and possible evolution (including best available technology and research)

Research and development

There are a number of areas where the performance of heat pumps can be improved by performing research and development activities.

Examples of possible improvements are:

- better control and operation strategies;
- adoption of heat pumps as a smart grid component;
- more efficient components;
- better integration with other systems such as ventilation, water heating, air conditioning, storages and solar thermal systems;
- increased use of natural refrigerants instead of HFC's in heat pumps.

Examples of best available technology

Air-to-air heat pumps of better quality normally have variable-speed compressors. The best available technology has a seasonal coefficient of performance (SCOP) of 5.10 according to EU Ecodesign regulation EU 206/2012

⁵⁵ Energinet.dk; Danish Energy Agency. Technology Data for Individual Heat Production and Energy Transport. Copenhagen: Energinet.dk, 2013.

2.5.3 Conditions/restrictions related to the use of the technology (indication of required investments for application in all types of buildings)

Air-to-air heat pumps have to follow Ecodesign regulations on air conditioners. The requirements for equipment with cooling capacity below 12 kW (or in case the equipment has not cooling mode, 12 kW heating capacity) are given in regulation EU 206/2012. Requirements are given in the table below given in seasonal coefficient of performance (SCOP) in average European climate (Strasbourg – Budapest) or with simple Coefficient of Performance (COP) at 7°C outdoor temperature:

Table 2-7: Requirements for SCOP in average European Climate, cf. EU-Regulation 206/2012⁵⁶.

Global warming potential (GWP) of refrigerant	Split type (indoor and outdoor units) (SCOP)	Single unit, double duct (COP)_{rated}	Single unit, single duct (COP)_{rated}
Refrigerant with GWP above 150	3.80	2.60	2.04
Refrigerant with GWP of 150 or below	3.42	2.34	1.84

Larger air-to-air heat pumps are about to be regulated in upcoming Ecodesign regulation with energy efficiency requirements expected from 2018 and stricter requirements from 2021. The expected requirements in 2021 is an efficiency from primary energy of 137, except for heat pumps driven by an internal combustion engine, where expected efficiency requirement is 130 and for roof-top units, where it will be 125. For engine driven air-to-air heat pumps NO_x-emissions are expected to be limited to 240 mg/kWh (GCV) for gas fuelled equipment and 420 mg/kWh (GCV) for liquid fuelled equipment, both from 2018.

Technical restrictions regarding the connected central heating system

Air-to-air heat pumps are not connected to a central heating system.

The installation requires a breach in the building envelope for the air tube. Depending on the chosen model design, an

indoor unit will most likely occupy wall area in the room that the air-to-air heat pump will supply with heating/cooling.

2.5.4 Input and output (energy carriers)

Input

The input is the heat from ambient air collected by the outdoor heat exchanger and electrical energy to drive the process. The heat source is the ambient air.

Output

The output is heat for space heating delivered by heating air passing through the indoor unit.

Reversible air to air heat pumps can also deliver cold air for cooling purposes.

⁵⁶ European Commission, Commission Regulation (EU) 206/2012 of 6 March 2012 implementing Directive 2009/125/EC of the European Parliament and of the Council with regard to Ecodesign Requirements for Air Conditioners and Comfort Fans, 2012. <http://eur-lex.europa.eu/LexUriServ/LexUriServ.do?uri=OJ:L:2012:072:0007:0027:en:PDF>

2.5.5 Typical capacities

A range of capacities is available, typically from 3-8 kW_{heat} and 2-6 kW_{cool}.

2.5.6 Regulation ability (electricity)

Air-to-air heat pumps generate heat to meet the heating demand in the respective room nearly instantaneous. This is to be seen in relation to water-based systems, where higher flexibility can be reached due to the possibility of thermal energy storages. Thus, the regulation ability is very limited.

2.5.7 Advantages and disadvantages

Advantages

- Air-to-air heat pumps use ambient air as the heat source, i.e. a free heat source.
- Air-to-air heat pumps for heating purposes can be a supplement in rooms and buildings with electrical heating. Air-to-air heat pumps collect heat from outside air and supply it to the building by use of electricity. The SCOP will typically be around three. This means that the yearly electricity consumption in rooms with electrical heating can be reduced to one third by installing an air-to-air heat pump.
- A special advantage of air-to-air heat pumps is that they do not need a heat distribution system for space heating. In houses with electrical heating, there is normally no heat distribution system, but the air-to-air heat pump can reduce the energy consumption significantly without installation of radiators or floor heating
- Reversible air-to-air heat pumps can cover a possible cooling demand and also cover a heating demand, when necessary. Heat pumps for cooling can complement any heating technology.
- The outdoor installation is simple and will only need very limited outdoor space and do not need any earthwork operations.
- An air-to-air heat pump is normally a smaller investment than other types of heat pumps. It will cost approximately 25 % of the price of a brine-to-water heat pump.
- Reversible air-to-air heat pumps can cover both the heating and cooling demand in a room, limiting the needed investments to one unit.

Disadvantages

- There is generally low convergence of good operation conditions (high ambient temperatures) and high heat demand. The COP is partially a function of the outdoor-temperature, thus the COP is very low when the heating demand is at its highest.
- Since the air-to-air heat pumps normally only cover 60-80 % of the heating demand in the house, more air-to-air heat pumps or a multi-split system are needed if the overall electricity demand is to be reduced to one third. But one air-to-air heat pump in an electrical heated house will reduce the electricity consumption significantly under any circumstances.
- The disadvantage of this type of installation is that the heat from the heat pump can only be delivered in the room where the indoor unit is installed (often the living room). As mentioned before, the air-to-air heat pump can

cover 60-80 % of the overall heat demand. Other rooms will need supplementary heating, e.g. electrical heating or another air-to-air heat pump.

- In cold humid periods, ice will build up on the outdoor heat exchanger and thereby decrease the evaporation temperature and the efficiency. Therefore, de-frosting of the outdoor heat exchanger is needed during cold and humid periods, causing an increased energy consumption. There are several heat pumps suited for Nordic climates on the market today. The difference between these and conventional air-to-air heat pumps is primarily due to regulation as the compressor can be optimized towards e.g. low outdoor temperatures through flow rates. Furthermore, a different outdoor-unit may be applied, allowing for more ice to grow on the outdoor-unit, before cutting out.

2.5.8 Environmental considerations

General for heat pumps

The heat pumps use F-gases (HFCs) as refrigerants. F-gases are fluorinated gases (HFCs, PFCs and SF₆), which are potent greenhouse gases. They are covered by the Kyoto Protocol.

The HFCs (HydroFluoroCarbons) are the most important, and they are frequently used in the refrigeration industry as the working fluid in the refrigeration cycle.

There are many different refrigerants based on HFCs. The most important are HFC-134a (R134a) and HFC mixtures: R404A, R410A and R407A. The most common refrigerants based on HFCs have Global Warming Potentials (GWP) of about 1,500 to 4,000 compared to CO₂, which has a GWP of 1.

Fluids that contain HFC with GWP >2 500 (R404 and R507) are banned by 2020. Fluids with GWP>150 (including R134a) are banned by 2022.⁵⁷

There are, however, some heat pumps working with natural refrigerants (including R290 – propane), but this is a minority. In the future, it will be possible to replace F-gases by natural refrigerants or other less harmful refrigerants. This change is mainly driven by regulation, and the economic implications of applying natural refrigerants will be reduced with increasing penetration.

Natural refrigerants are substances that can be found in nature's own cycle, e.g. ammonia, hydrocarbons, CO₂, water and air. None of the refrigerants in the group of natural refrigerants are perfect, and they all have technical limitations. Therefore, natural refrigerants have to be chosen with care, and one fluid cannot cover all applications.

Different types of heat pumps use the same types of refrigerants. The above description is therefore representative for all types of heat pumps.

The environmental impact due to the use of electricity will depend on the way the electricity is produced.

2.5.9 Applications with combinations of other technologies

As air-to-air heat pumps only cover the demand for space heating, other technology has to be applied to cover the hot tap water demand in a building.

As air-to-air heat pumps only cover approximately 60-80 % of the total space heating demand of a building, supplementary technologies are necessary for other rooms than

⁵⁷ <http://naturalrefrigerants.info/global-regulations-2/>

the one supplied by the air-to-air heat pump. A typical choice for this is electric heating.

2.5.10 Indications of notable differences of techno-economic performance or applicability across Europe

Table 2-8: Techno-economic data for electric heat pumps, air-to-air. Comments on these data are provided in the table below.

	2.5 HP-e-air-to-air	DK	PT	H	D
Small	Nominal heating/cooling capacity for one unit (kW)	5	3.6 / 2.5	5	4.2 / 3.5
	CAPEX (€/kWth)	440	639	312	714
	CAPEX (€/unit)	2 200	2 300	1 560	3 000
	- hereof equipment (%)	80%	85%		90%
	- hereof installation (%)	20%	15%		10%
	Additional specific investment (€/unit)			230	
	Fixed O&M (€/unit/year)	34	60	30	135
	Variable O&M (€/GJ)				
Large	Nominal heating/cooling capacity for one unit (kW)		63.7 / 62.3		
	CAPEX (€/kWth)		425		
	CAPEX (€/unit)		27		
	- hereof equipment (%)		75%		
	- hereof installation (%)		25%		
	Additional specific investment (€/unit)				
	Fixed O&M (€/unit/year)		650		
	Variable O&M (€/GJ)				

DK	<p>Improvement of delivered energy costs is assumed to be 25 % in 2030 and 35 % in 2050. The improvement is equally split between the efficiency and the cost. For systems used in one-family houses, the price variation depending on the size is limited and an average price is used.</p> <p>The O&M cost corresponds to an expense of EUR 110 each third year.</p> <p>A large coverage requires that the doors between the room where the air-to-air heat pump is placed and the adjoining rooms are open or an air circulation system is installed.</p> <p>The heat production capacity is assumed to be respectively 5 kW in existing one-family houses and 3 kW in new one-family houses.</p>
PT	<p>For electric heat pumps, the emissions depend on how the electricity is produced. Emission factors for electricity in Portugal can for instance be found in socio-economic assumptions for energy projects published by IEA, page 66 in ref. 4</p> <p>Large scale calculations based on an installation of a 17.5 kW chiller on top of laboratory facilities. O&M according to contract maintenance of an air-to-air unit at the Gulbenkian Institute of Science.</p>
H	<p>There is no Hungarian producer on the market. The most popular imported brand is the Daikin.</p> <p>Heat-pump owners can apply for a special tariff, introduced by the state as a</p>

	<p>"H" tariff, valid from 15th of October until 15th of April, and the price is október 15. - április 15. HUR 29.16/kWh (gross price, 7.6 cent/kWh). The normal price for households: option A): until the consumption of 1320 kWh/year 11,4 euro cent/kWh; from that 12.1 cent/kWh, or option B): during on-peak period (from 6 am to 22 pm - winter time, from 7 am to 23 pm - summer time) 13.9 cent/kWh; 10.5 cent/kWh during off-peak period.</p> <p>Outdoor unit: from EUR 286/kW + indoor units (from EUR 26/kW). Installation price of the outdoor equipment and one indoor: 161 EUR (for equipment which was not delivered by the company: 178 EUR. If the indoor equipment is further then 3 m: 16 EUR/m. A further indoor equipment does not enlarge the price, only with the additional price per meter above 3 m.</p> <p>No large scale available. The biggest one identified is a 28 kW Daikin unit http://daikinrvv.hu/termek/daikin-erq-inverter-hoszivattyus-kulteri-egyseg-28-kw/213</p>
D	<p>Coverage is highly dependent on the application. Can cover the demand of a single room or a complex of rooms or be a supplement to another appliance.</p> <p>Noise level approximately 30dB(A) in normal operation.</p> <p>Installation approximately 8 man-hours.</p> <p>Annual maintenance and service. Approximately 2.5 man-hours.</p>

There are variations in the CAPEX and other parameters for the four countries. These are ascribed to the data quality (few data sources). The level of costs is confirmed by IEA, which has a cost of 600 and 535 EUR/kW for 12 kW and 300 kW units respectively, and a level of fixed O&M costs of 180 and EUR 750/unit/year.⁵⁸

Air-to-air heat pumps are mature technology, some development of the parameters is expected. An increase of COP and a decrease of CAPEX for small capacities is expected.⁵⁹ IEA indicates significant reductions of CAPEX and increase of COP by 2030 and 2050.⁶⁰

2.5.11 Datasheet

Please refer to the detailed datasheets in the spreadsheet at <http://data.europa.eu/89h/jrc-etri-techno-economics-smaller-heating-cooling-technologies-2017>

2.5.12 Definitions (applies to all sections on heat pumps)

COP/SCOP

The coefficient of performance (COP) describes the ratio between the energy input (e.g. electricity) and the heat output at a specified point of operation. The Seasonal Coefficient of Performance (SCOP) describes the total ratio between energy input and output throughout a year, taking temperature variances and loads of the heat pumps into consideration.

⁵⁸ IEA Energy Technology Network, ETSAP – Energy Technology Systems Analysis Programme, Technology Brief June 2012, Table 1, page 9 in http://iea-etsap.org/E-TechDS/PDF/R02%20Heating%20and%20cooling%20FINAL_GSOK.pdf

⁵⁹ Danish data and ETRI report (table 73, page 102) have similar projections of COP and reduction of CAPEX. https://setis.ec.europa.eu/system/files/ETRI_2014.pdf

⁶⁰ Technology Roadmap, table 7, page 25 in: https://www.iea.org/publications/freepublications/publication/buildings_roadmap.pdf

EER/SEER

The EER and SEER describe the ratio between the energy input (e.g. electricity) and the cooling output at a specified point of operation (EER) and as a total over a year (SEER) respectively.

Refrigerant

The refrigerant is the substance (typically a fluid) that is circulated in a heat pump. Its thermodynamic properties, in combination with pressure control, lets the refrigerant evaporate at low temperatures. The energy that is submitted in relation to the phase shift can be utilized for heating (condensation) or cooling (evaporation) purposes, e.g. to cool/heat water or air. Typical refrigerants are fluorocarbons, but natural refrigerants like ammonia or carbon dioxide are being used too, which limits the environmental hazardousness of the heat pumps.

Heat/cooling source

All heat pumps have a "hot" and a "cold" side. Depending on which function is the purpose of installation (unless it is an appliance for combined cooling and heating), there must be a heat or cooling source. The main source for this is ambient heat or ambient cold, i.e. the surplus heat or cold that is produced in the process can be submitted to ambient air or soil, in order to regenerate (cooling) or evaporate (heating) the refrigerant. The source that supplies this energy for the regeneration/evaporation of the refrigerant is called the heat or cooling source respectively.

2.6 Heat pumps, electrical – air to water

2.6.1 Technical description

Air-to-water heat pumps draw heat from ambient air and use a water-based heating system to supply the heat to the building. The heat pump can also produce hot tap water.

Air-to-water heat pumps are normally designed to cover between 95 and 98 % of the heating demand. The remaining heat demand is covered by electrical heating. It is possible to supplement the heat pump by a solar heating system.

An air-to-water heat pump is normally chosen where there is not enough available outdoor area for ground heat collectors, but where there is a water-based heat distribution system in the building. Air-to-water heat pumps cannot deliver water temperatures higher than 55°C, which means that the radiators have to be able to cover the heat demand with temperatures below this.

In order to obtain these sufficient low supply temperatures, it is in many cases necessary to install a larger heat capacity of the heat emission system, e.g. by installing larger radiators and/or by improving the insulation level of the building envelope. In Section 3.10, examples are given for the cost of installing larger radiators. In many cases, however, the improvement of the building envelope may be an economic profitable option anyway, and for new buildings, it will be a necessity due to requirements in the building regulations.

Some air-to-water heat pumps are designed specifically for supplying only hot tap water. This type of air-to-water heat pumps is used in a number of summer residences, especially if there is a large consumption of hot tap water. The data sheets presented by the end of this chapter show data for heat pumps covering both space heating and hot tap water.

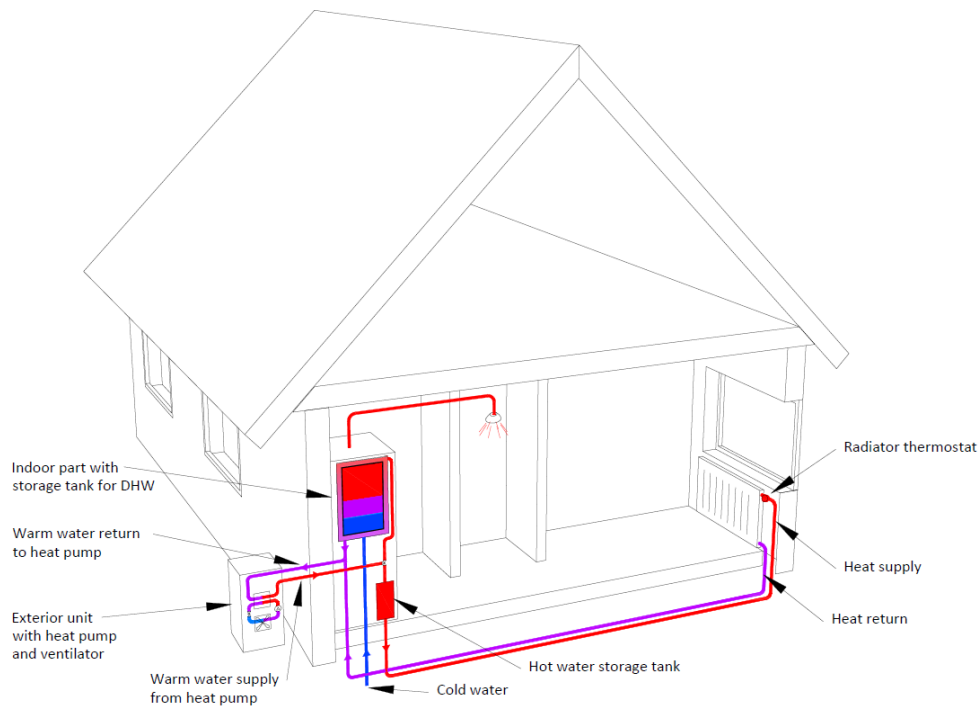

Figure 2-8: Electrical heat pump, air-to-water⁶¹

About 20 % of the air-to-water heat pumps in the market today have capacity regulation, making it possible to regulate the thermal output of the heat pump on

The best efficiency is obtained with a capacity regulation ensuring that the supply temperature to the heat distribution system does not increase unnecessarily when the heat pump is running, because the heat pump efficiency will increase with lower temperatures.

If the heat pump is on/off regulated and has a small storage tank, the heat pump can start and stop often, which will lower the efficiency. A sufficiently large storage tank is therefore important with on/off regulation.

2.6.2 Current use and possible evolution (including best available technology and research)

Research and development

There are a number of areas where the performance of heat pumps can be improved by performing research and development activities. This counts for most types of heat pumps.

Examples of possible improvements are:

- better control and operation strategies;
- adoption of heat pumps as a smart grid component;
- more efficient components;
- better integration with other systems such as ventilation, water heating, air conditioning, storages and solar thermal systems;
- increased use of natural refrigerants instead of HFCs in heat pumps.

⁶¹ Energinet.dk; Danish Energy Agency. Technology Data for Individual Heat Production and Energy Transport. Copenhagen: Energinet.dk, 2013.

Examples of best available technology

2.6.3 Conditions/restrictions related to the use of the technology (indication of required investments for application in all types of buildings)

The EU Ecodesign regulation EU 813/2013 sets requirements for new heat pumps' energy efficiency used with water-based (hydronic) heating systems of 100 % (115 % for low-temperature heat pumps, as seasonal efficiency from primary energy and reduced by accounting for temperature controls as explained in Commission Communication in Official Journal C 207. From 26. September 2017 this efficiency requirement will be increased to 110 % (125 % for low-temperature heat pumps)

The same regulation also sets efficiency requirements for hot tap water production, if this function is included. The energy efficiency requirements depend on the size (tapping capability) of the water heating function.

Technical restrictions regarding the connected central heating system

Heat pumps work most efficiently when the temperature-lift is little and the supply temperature is close to the temperature of the heat source. Furthermore, most commercially available electrical heat pumps have an upper limit for the supply temperature of approximately 60-65 °C. This may be too low for older, existing central heating systems. This may be addressed by increasing the radiator capacity or by improving the insulation level of the building.

2.6.4 Input and output (energy carriers)

Input

The input is heat from ambient air collected by the outdoor air heat exchanger and electrical energy to drive the process.

Output

The output is heat for primarily space heating and/or hot tap water.

2.6.5 Typical capacities

The size of air-to-water heat pumps ranges from approximately 4 kW up to several hundred kW heating capacity, covering the needs for both space heating and hot tap water in both low-energy buildings and large buildings.

2.6.6 Regulation ability (electricity)

Cf. Section 1.5.3, the regulation ability of air-to-water heat pumps is related to the available thermal storage capacity. Air-to-water heat pumps can be regulated to 20 % of nominal capacity or operate as on/off. The regulation ability has been investigated in several contexts, e.g. the READY- and EcoGrid-projects in Denmark.

The German Heat Pump Association (Bundesverband Wärmepumpe e.V.) has developed the "Smart-Grid-Ready-Label". Heat pumps carrying this label can partially be controlled by a third party⁶². The Smart-Grid-Ready-Label is only applicable in Germany, but the application of heat pumps in smart energy systems is a development focus for e.g. the European Heat Pump Association.

⁶² For more information, please refer to the technical regulation for the SG-Ready Label, v. 1.1. An updated, comprehensive overview over heat pumps with the SG-Ready label is found on the BWP homepage: <http://www.waermepumpe.de/sg-ready/>.

2.6.7 Advantages and disadvantages

Advantages

- The general advantage of heat pump technologies is that they normally use a free low-temperature heat source.
- High energy-efficiency (although less than brine/water-to-water heat pumps in colder regions)
- Easier and cheaper (20-30 % less) to install than a water- or brine-to-water heat pump
- Possibility for flexible electricity consumption, when combined with an accumulation tank.

Disadvantages

- Compared to brine-to-water heat pumps, the air-to-water heat pump is less efficient because the air temperature to the outdoor heat exchanger will be lower than the ground temperature when there is a large demand for heating. Moreover, ice will build up on the outdoor heat exchanger and thereby decrease the evaporation temperature and the efficiency. Therefore, defrosting of the outdoor heat exchanger is needed during cold and humid periods, causing increased energy consumption.
- Moderate noise pollution may be an issue in urban areas.
- Air-to-water heat pump efficiency depends on the temperatures on the cold (outdoor) and the warm side (indoor) of the heat pump. Lower temperatures on the cold side as well as higher temperatures on the warm side decrease the efficiency. The heat demand is normally higher when outdoor temperatures are low.
- High COP may not be achievable when applying the heat pump in an existing dwelling with a central heating system with high flow temperature, as temperatures above approximately 55°C have to be reached by the use of a continuous flow water heater.
- For heat pumps supporting a water based heat distribution system, the supply temperature plays an important role for the efficiency. Lower supply temperature gives higher efficiencies, and therefore heat pumps for floor-heating (35°C) reach higher SCOP, compared to heat pumps for radiators (55°C).

2.6.8 Environmental considerations

Please refer to Section 1.3.2 for the general environmental considerations regarding the refrigerant in heat pumps.

Furthermore, air-to-water heat pumps have a local environmental impact due to the noise from the outdoor unit.

2.6.9 Applications with combinations of other technologies

Air-to-water heat pumps will typically be installed with an integrated electric continuous-flow water heater in order to secure a backup and peak capacity. Furthermore, air-to-water heat pumps can be combined with solar heating units or boilers. The latter can limit the need for installed heat pump capacity, as the boiler can cover peak demands and operation with very low outdoor temperatures, when operation of the heat pump is inefficient or impossible.

2.6.10 Indications of notable differences of techno-economic performance or applicability across Europe

Table 2-9: Techno-economic data for electric heat pumps, air-to-water. Comments on these data are provided in the table below.

	2.6 HP-e-air-to-water	DK	PT	H	D
Small	Nominal heating/cooling capacity for one unit	10	8.5	8.4	20
	CAPEX (€/kW)	1100	233	599	769
	CAPEX (€/unit)	11 000	1 982	5 028	15 389
	- hereof equipment (%)	85%	87%	70%	95%
	- hereof installation (%)	15%	13%	30%	5%
	Additional specific investment (€/unit)				
	Fixed O&M (€/unit/year)	150	60		246
	Variable O&M (€/GJ)				
Large	Nominal heating/cooling capacity for one unit	750	400		
	CAPEX (€/kW)	800	300		
	CAPEX (€/unit)	600 000	119 910		
	- hereof equipment (%)	85%	70%		
	- hereof installation (%)	15%	30%		
	Additional specific investment (€/unit)				
	Fixed O&M (€/unit/year)	450			
	Variable O&M (€/GJ)				
DK	<p>Size of heating emitters corresponds to a new system.</p> <p>Improvement of delivered energy costs is assumed to be 25 % in 2030 and 35 % in 2050. The improvement is equally split between the efficiency and the cost.</p> <p>The heat pump unit described consists of a heat pump including an electrical backup. The total unit covers 100 % of the heat demand as described and with the efficiency as described. It is assumed that the heat pump will deliver 95 % of the heat demand and the electrical backup will deliver 5 % of the heat demand.</p> <p>The O&M cost corresponds to an expense of EUR 150 each year for one-family houses and three times more for apartment buildings.</p> <p>An air-to-water heat pump will work in combination with a hot water storage tank. The price of the tank is not included in this price. An air-to-water heat pump will often replace an oil-fired boiler or a natural gas boiler where there already is a storage tank installed.</p>				
PT	<p>The low CAPEX is confirmed. The source is the largest energy company in Portugal. More than 500 heat pumps sold in 2015.</p> <p>The O&M costs are assumed the same as for air-to-air unit.</p> <p>Large scale: 4x 100 kW DAIKIN Commercial model EWYQ-G-XS 100, page 47 in ref. 1</p> <p>The shares are based on Burerus installers records. 30 % of the total price is the installation costs.</p>				

H	<p>There is no Hungarian producer on the market. The most popular imported brand is the Daikin, but the technology is not so popular.</p> <p>Installation costs are for a single-family house of 150 m².</p> <p>A 58 kW heat pump from a Hungarian company (http://www.napelem-napkollektorok.hu/akcios-termekeink/hoszivattyu-ar), however for this large scale there is no exact price.</p>
D	<p>Increase of radiator area may be necessary in order to achieve lower supply temperatures and thus increase the COP (no costs for this included in the above). O&M-prices include annual maintenance and service.</p>

There are variations in the CAPEX and other parameters for the four countries. These are ascribed to the data quality (few data sources). The level of costs is confirmed by IEA, which has a cost of 1 275 and 670 EUR/kW for 12 kW and 300 kW units respectively, and a level of fixed O&M costs of EUR 180 and 1 200/unit/year.⁶³

Air-to-water heat pumps are mature technology, but some development of the parameters is expected. An increase of COP and a decrease of CAPEX for small as well as large capacities is expected.⁶⁴ IEA indicates significant reductions of CAPEX and increase of COP by 2030 and 2050.⁶⁵

2.6.11 Datasheet

Please refer to the detailed datasheets in the spreadsheet at <http://data.europa.eu/89h/jrc-etri-techno-economics-smaller-heating-cooling-technologies-2017>

2.7 Heat pumps, electrical – ground source (horizontal/vertical)

2.7.1 Technical description

Most brine-to-water heat pumps draw heat from the ground through a ground source heat collector. The heat collection can be achieved through establishing horizontal pipes about a meter down in the ground with anti-freeze brine collecting the heat from the ground. This type is also called a ground source heat pump. Instead of horizontal pipes, it is also possible to use vertical pipes placed with depth up to 250 m. If horizontal pipes are installed in a garden, the affected parts of the garden have to be re-established after the pipes are laid. In many cases, this makes it only a feasible solution, when establishing the horizontal pipes as a part of a planned redesign of the garden, re-sowing of a lawn etc. Vertical heat collectors (drillings) are a more expensive but less area consuming solution and can be a good alternative, when space is limited.

Other possible energy sources for pipe systems are e.g. rivers, lakes and ground water. The utilization of these are usually only feasible in larger installations (e.g.

⁶³ IEA Energy Technology Network, ETSAP – Energy Technology Systems Analysis Programme, Technology Brief June 2012, Table 1, page 9 in http://iea-etsap.org/E-TechDS/PDF/R02%20Heating%20and%20cooling%20FINAL_GSOK.pdf

⁶⁴ Danish data and ETRI report (table 73, page 102) have similar projections of COP and reduction of CAPEX. https://setis.ec.europa.eu/system/files/ETRI_2014.pdf

⁶⁵ Technology Roadmap, table 7, page 25 in: https://www.iea.org/publications/freepublications/publication/buildings_roadmap.pdf

complexes or for utility companies) due to higher investment costs and increased demand for environmental studies.

The heat pumps are normally designed to cover between 95 % and 98 % of the heating demand. The remaining heat demand is covered by direct electrical heat sources. It is possible to supplement the heat pump by a solar heating system.

Brine-to-water heat pumps have a high average efficiency over the year due to the more stable temperatures in the ground. Brine-to-water heat pumps cannot deliver water temperatures higher than 55°C, which means that the radiators have to be able to cover the heat demand of the house with temperatures below 55°C.

In order to obtain these sufficient low supply temperatures, it is in many cases necessary to install a larger heat capacity of the heat emission system, e.g. by installing larger radiators and/or by improving the insulation level of the building envelope. In section 3.9.1, some examples are given for the cost of installing larger radiators. In many cases, however, the improvement of the building envelope may be an economic profitable option anyway, and for new buildings it will be a necessity due to requirements in the building regulations.

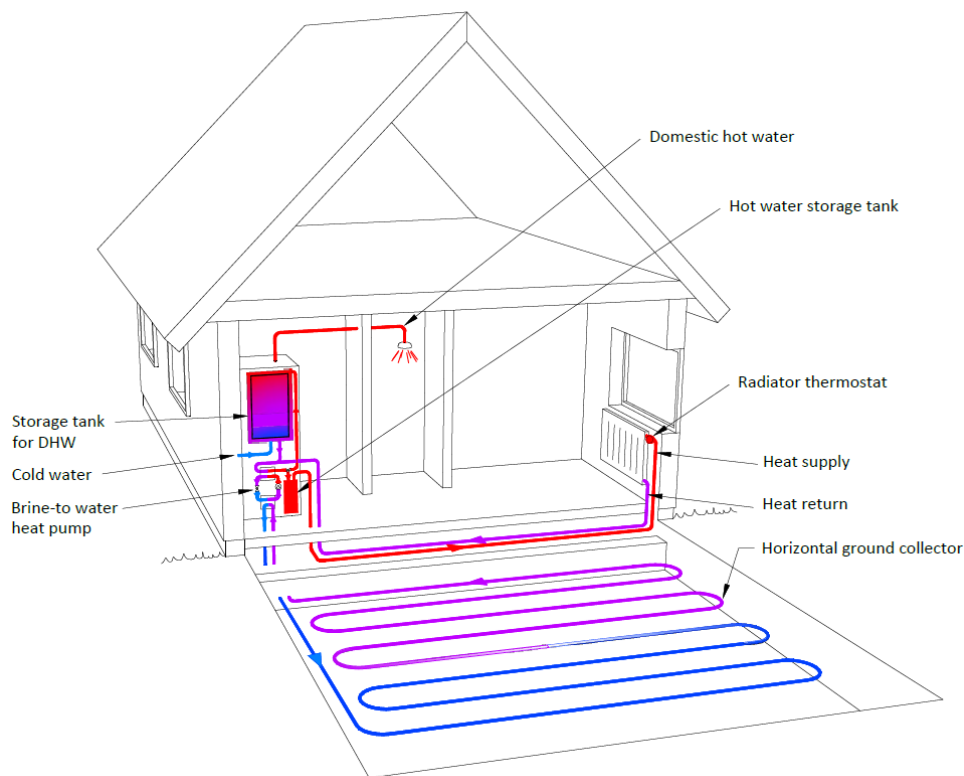

Figure 2-9: Electrical heat pump, brine-to-water⁶⁶

For brine-to-water heat pumps as well as other types of heat pumps, there are two main types of regulation. There is on/off regulation and capacity regulation, which is continuously variable down to about 20 % of the maximum capacity.

Capacity regulation works through a variable speed compressor where the amount of refrigerant flow through the refrigerant cycle is adapted to the demand. In on/off

⁶⁶ Energinet.dk; Danish Energy Agency. Technology Data for Individual Heat Production and Energy Transport. Copenhagen: Energinet.dk, 2012.

regulation, the compressor will work full load and stop at intervals adapted to the heat demand.

Brine-to-water heat pumps with capacity regulation do exist on the market today, but is a special feature and not very common yet.

The best efficiency is obtained with a capacity regulation ensuring that the supply temperature to the heat distribution system does not increase unnecessarily when the heat pump is running, because the heat pump efficiency will increase with lower temperatures.

If the heat pump is on/off regulated and has a small storage tank, the heat pump may start and stop often, which will lower the efficiency. A sufficiently large storage tank is therefore important with on/off regulation.

2.7.2 Current use and possible evolution (including best available technology and research)

Research and development

There are a number of areas where the performance of heat pumps can be improved by performing research and development activities.

Examples of possible improvements are:

- better control and operation strategies;
- adoption of heat pumps as a smart grid component;
- more efficient components;
- better integration with other systems as ventilation, water heating, space conditioning, storages and solar thermal systems;
- increased use of natural refrigerants instead of HFC's in heat pumps.

According to EU Ecodesign regulation EU 813/2013 the best available technology has a seasonal energy efficiency of 145 % based on primary energy, used in EU average climate (Strasbourg – Budapest), and used with a medium-temperature heating system.

2.7.3 Conditions/restrictions related to the use of the technology (indication of required investments for application in all types of buildings)

The EU Ecodesign regulation EU 813/2013 sets requirements for new heat pumps' energy efficiency used with water-based (/hydronic) heating systems as explained in annex II.

Requirements may apply for the sound levels if outdoor units.

Technical restrictions regarding the connected central heating system

For horizontal ground source collectors, there is a space requirement for the installation of pipes. Vertical drillings may be an alternative, when space is limited, cf. the elaborations in this chapter.

Heat pumps work most efficiently when the temperature-lift is little and the supply temperature is close to the temperature of the heat source. Furthermore, most commercially available electrical heat pumps have an upper limit for the supply temperature of approximately 60-65°C. This may be too low for older, existing central heating systems. This may be addressed by increasing the radiator capacity or by increasing the insulation level of the building.

2.7.4 Regulation of drilling depths may apply. Input and output (energy carriers)

Input

The input is heat from an available heat source and electrical energy to drive the process. The heat source is most commonly the top soil (horizontal ground collector), but can also be the ground (vertical ground collector), water (lake, streams or sea water) or ambient energy absorbers (placed outdoors or roof integrated). Ambient energy absorbers can be considered as a kind of solar collector.

Output

The output is heat for primarily space heating and possible hot tap water.

2.7.5 Typical capacities

There is a range of capacities available, ranging from 1.5 kW up to several hundred kW covering the needs for both space heating and hot tap water in both low-energy buildings and large buildings.

2.7.6 Advantages and disadvantages

Advantages

- Uses a free low-temperature heat source
- The COP is more stable than e.g. with the air-to-water heat pump, as the ground temperature tends to be more stable than the ambient temperatures
- Hot tap water and space heating demand can be covered by one single unit
- No noise-pollution to neighbours (opposed to air-to-water heat pumps)
- The possibility of either vertical or horizontal heat collectors make it a flexible solution and improve the overall applicability

Disadvantages

- For heat pumps supporting a water based heat distribution system, the supply temperature plays an important role for the efficiency. Lower supply temperature gives higher efficiencies, and therefore heat pumps for floor-heating (35 °C) have better efficiency than heat pumps for radiators (55 °C).
- The installation of heat collectors necessitate earthwork operations. Horizontal ground collectors need available ground area corresponding to a maximum consumption of 40 kWh/m² per year (under Danish climatic and ground conditions) where the area is the horizontal area.
- The increased investments cannot always be counterbalanced by the reduced costs of energy. A brine-to-water heat pump will be approximately 15 % more efficient than an air-to-water heat pump. The overall price including earthwork and piping is about 20-30 % more than for air-to-water heat pumps.

2.7.7 Environmental considerations

Please refer to Section 1.3.2 regarding the environmental considerations regarding the refrigerants.

Typically an anti-freeze-brine is circulated in the heat collectors to secure the system against frost damages and keep the system operational at temperatures below freezing temperature. This poses a potential environmental threat, in case the heat collectors are damaged. Due to the depth of installation (especially for vertical collectors), the risk of damages is very limited. Furthermore, wrong dimensioning of heat collectors of early installations has led to freezing of the top soil of gardens, where the heat collectors are typically placed. This can be avoided, by dimensioning

the heat pump and the collectors correctly according to the heat demand of the building. The same can apply for drilled probes.

2.7.8 Applications with combinations of other technologies

Heat pumps in water-based heating systems are usually supplied with a continuous-flow water heater, in order to cover peak demands (thus limiting the needed capacity of the heat pump) and secure high supply temperatures when necessary.

Ground-source heat pumps can be installed in combination with other boiler technologies, e.g. a natural gas or wood pellet boiler. The heat pump will in this case typically be dimensioned to cover a base demand (e.g. the hot tap water demand in summer) and be supplied with the other boiler as a backup for peak demands.

2.7.9 Indications of notable differences of techno-economic performance or applicability across Europe

The applicability of ground source heat exchangers are highly dependent on the local conditions, especially the average ambient temperature and the heat conductivity of the top soil layers. There have been several European Projects to estimate the surface geothermal potential across Europe, e.g. the ThermoMap-project⁶⁷, where the surface (0-10m) geothermal potential is estimated based on soil and groundwater data.

The German Federal State of Hessen has developed maps⁶⁸ that present the potential for vertical heat exchanger probes. Maps are presented for the entire Federal State, down to Municipality level and show, how varying the conditions for vertical heat collectors can be.

⁶⁷ FAU GeoZentrum Nordbayern et. Al, *Homepage of the ThermoMap-project*, <http://www.thermomap-project.eu/>, accessed December 2016, updated August 2013.

⁶⁸ HLNUG (Regional Authority for Environmental Protection and Geology of the Federal State of Hesse), *Map of potentials for Hydrogeologicals and Water Management*, <http://www.hlnug.de/themen/geologie/erdwaerme-geothermie/oberflaechennahe-geothermie/karten-standortbeurteilung.html>, accessed November 2016, updated September 2016.

Table 2-10: Techno-economic data for electric heat pumps, ground source. Comments on these data are provided in the table below.

	2.7 HP-e-ground	DK	PT	H	D
Small	Nominal heating/cooling capacity for one unit (kW)	10	9.2 / 2.3		15
	CAPEX (€/kWth)	1 400	867		1090
	CAPEX (€/unit)	14 000	7 980	3 000	16 350
	- hereof equipment (%)	70%			95%
	- hereof installation (%)	30%			5%
	Additional specific investment (€/unit)	5 000		2 800	9 450
	Fixed O&M (€/unit/year)	200			300
	Variable O&M (€/GJ)				
Large	Nominal heating/cooling capacity for one unit (kW)	750			220
	CAPEX (€/kW)	900			299
	CAPEX (€/unit)	675 000			65 700
	- hereof equipment (%)				95%
	- hereof installation (%)				5%
	Additional specific investment (€/unit)	405			185
	Fixed O&M (€/unit/year)	600			
	Variable O&M (€/GJ)				

DK	<p>The heat pump unit described consists of a heat pump including an electrical backup. The total unit covers 100 % of the heat demand as described and with the efficiency as described. It is assumed that the heat pump will deliver 97 % of the heat demand and the electrical backup will deliver 3 % of the heat demand.</p> <p>A vertical heat collection can be used instead of horizontal heat collectors. This will reduce the need for digging up the ground but increase the costs.</p> <p>A brine-to-water heat pump will work in combination with a hot water storage tank. The price of the tank is not included in this price. Brine-to-water heat pumps will often replace an oil-fired or natural gas boiler, where there is already a storage tank installed.</p> <p>The O&M cost corresponds to an expense of EUR 200 each year for one-family houses and three times more for apartment buildings.</p> <p>The investment cost is considered as a typical investment cost based on practical experiences. It should be noted that the investment cost can vary a lot from unit to unit.</p>
PT	<p>This technology is not common in Portugal. The existing installations are in university campus.</p> <p>Floor heating installation. Forward temperature 35 C, return temperature 30C⁶⁹. Page 185 ref. 1</p>
H	<p>There is one Hungarian company⁷⁰, which produce ground source heat pumps.</p>

⁶⁹ Buderus, *Price Table for Portugal 2016 (Tabela geral de preços 2016)*
http://www.buderus.pt/files/Buderus_Tabela_geral_de_pre%C3%A7os_2016_PT.pdf, 2016

	<p>Investment costs for the whole system, including the installation of the underground tubes as well. For a family house with 150 m².</p> <p>Additional investment: price of the horizontal collector is EUR 2 800; underground tubes.</p>
D	<p>Depending on the case, it may be beneficial to cover (parts of) the HTPW-demand by a continuous flow heater (electric).</p> <p>The needed heat capacity of the probe(s) depends on the case (heat conductivity of the soil, needed heat effect in the building etc.). The presented estimate is based on a ground with an average heat conductivity of 52.5 W/m and a needed heating effect of the probe of 7 kW. Prices for drillings including probes are typically in the range EUR 60-80/m.</p> <p>Increase of radiator area may be necessary in order to achieve lower supply temperatures and thus increase the COP. No costs for this are included in the above.</p> <p>Investment costs includes 300 l buffer tank.</p>

There are small variations in the CAPEX and other parameters for the four countries. These are ascribed to the data quality (few data sources). The level of costs is confirmed by IEA, which has a cost of 1 625 for a 12 kW unit, and a level of fixed O&M costs of EUR 180/unit/year.⁷¹

Ground source heat pumps are mature technology, some development of the parameters is expected. An increase of COP and a decrease of CAPEX for small as well as large capacities is expected.⁷² IEA indicates more significant reductions of CAPEX and increase of COP by 2030 and 2050 than the above-mentioned references.⁷³ Heat Roadmap Europe indicates similar modest reductions of CAPEX for 2020 and 2030.

2.7.10 Datasheet

Please refer to the detailed datasheets in the spreadsheet at <http://data.europa.eu/89h/jrc-etri-techno-economics-smaller-heating-cooling-technologies-2017>

⁷⁰ Geowatt, Company Homepage, *Heating/Cooling/HMV heat pumps*, http://www.geowatt.hu/products_main_en/heating-hmv-heat_pumps_en, accessed June 2016, updated 2013.

⁷¹ IEA Energy Technology Network, ETSAP – Energy Technology Systems Analysis Programme, Technology Brief June 2012, Table 1, page 9 in http://iea-etsap.org/E-TechDS/PDF/R02%20Heating%20and%20cooling%20FINAL_GSOK.pdf

⁷² Danish data and ETRI report (table 73, page 102) have similar projections of COP and reduction of CAPEX.

Danish Data: Energinet.dk; Danish Energy Agency. Technology Data for Individual Heat Production and Energy Transport. Copenhagen: Energinet.dk, 2013.

ETRI: European Commission, Joint Research Center, 2014, ETRI 2014 – Energy Technology Reference Indicator projections for 2010-50. https://setis.ec.europa.eu/system/files/ETRI_2014.pdf

⁷³ Technology Roadmap, table 7, page 25 in: https://www.iea.org/publications/freepublications/publication/buildings_roadmap.pdf

2.8 Heat pumps, electrical – groundwater

2.8.1 Technical description

The technical principles in groundwater-heat pumps is very similar to (vertical) ground source heat pumps. The main differences are the way the heat source is utilized, as ground water heat pumps usually operate in an open circuit, using the ground water directly as a heat source, before reinjecting it by pumping or percolation. Due to this open circuit, it is important to secure that no pollution of the groundwater can happen, which must be secured in the design of the heat pump. Groundwater is generally characterized by more stable temperature profiles than the more shallow layers of the soil and thus less seasonal variation in the COP is achievable for most groundwater systems.

The depth of the groundwater layers varies by the location and can vary from few meters to several hundreds. General knowledge about the groundwater characteristics can thus be used as an indication of the potential of groundwater as a heat source.

Due to economy of scale factors regarding environmental screenings, drillings etc., groundwater heat pumps are only feasible for larger systems in the 100+kW range.

2.8.2 Current use and possible evolution (including best available technology and research)

According to EU Ecodesign regulation EU 813/2013 the best available technology has a seasonal energy efficiency of 145 % based on primary energy, used in EU average climate (Strasbourg – Budapest), and used with a medium-temperature heating system.

2.8.3 Conditions/restrictions related to the use of the technology (indication of required investments for application in all types of buildings)

The EU Ecodesign regulation EU 813/2013 sets requirements for new heat pumps' energy efficiency used with water-based (hydronic) heating systems as explained in Section 2.7.3.

Technical restrictions regarding the connected central heating system

Heat pumps work most efficiently when the temperature-lift is little and the supply temperature is close to the temperature of the heat source. Furthermore, most commercially available electrical heat pumps have an upper limit for the supply temperature of approximately 60-65 °C. This may be too low for older, existing central heating systems. This may be addressed by increasing the radiator capacity. If this does not solve the issue, the building is not suitable for air-to-water heat pumps.

2.8.4 Input and output (energy carriers)

Input

Groundwater as heat source, electricity as drive energy.

The flow is a crucial parameter, dependent on the ground conditions (permeability).

Output

The output is heat for primarily space heating and possible hot tap water.

2.8.5 Typical capacities

The typical capacity of groundwater heat pumps is in the 100s kW-range, as the necessary pre-study work regarding the ground water conditions and drilling make it a

too expensive solution for single house applications. Very good ground water conditions may make groundwater systems for single houses feasible too.

2.8.6 Advantages and disadvantages

Please refer to the general section on heat pumps (section 1.2.3)

2.8.7 Environmental considerations

Please refer to Section 1.3.2 for the general environmental considerations regarding heat pumps.

There are considerable environmental considerations regarding groundwater drillings in general and it must be secured that no contamination of the groundwater can happen – neither in the drilling phase, the utilization of water nor in relation to the heat pump.

2.8.8 Applications with combinations of other technologies

The same combinations as for ground source heat pumps.

2.8.9 Indications of notable differences of techno-economic performance or applicability across Europe

The applicability of ground water heat pumps differs very much across Europe, but also within member states, regions and municipalities. The criteria that have to be fulfilled in order for a ground water based heat pump system are:

- Groundwater is available
- The soil materials and structure make utilization for heat pumps possible (in terms of e.g. heat conductivity, temperature zones in the ground, enclosed aquifers that should not be drilled into etc.)Ground water utilization for heat pumps does not conflict with other interests in the area (e.g. protected dwells, natural protection sites etc.)

Table 2-11: Techno-economic data for electric heat pumps, ground water. Comments on these data are provided in the table below.

	2.8 HP-e-groundwater	DK	PT	H	D
Small	Nominal heating/cooling capacity for one unit (kW)			8.93	15
	CAPEX (€/kW)			433	1 200
	CAPEX (€/unit)			3 867	18 000
	- hereof equipment (%)				95%
	- hereof installation (%)				5%
	Additional specific investment (€/unit)			3 436	9 385
	Fixed O&M (€/unit/year)				300
	Variable O&M (€/GJ)				
Large	Nominal heating/cooling capacity for one unit (kW)				290
	CAPEX (€/kW)				300
	CAPEX (€/unit)				87 000
	- hereof equipment (%)				95%
	- hereof installation (%)				5%
	Additional specific investment (€/unit)				18 770
	Fixed O&M (€/unit/year)				
	Variable O&M (€/GJ)				
DK					
PT					
H	<p>There are two companies which produce water-water heat pump in Hungary. Spark produce heat pumps with capacity from 6-40 kW, Geowatt from 10-160 kW.</p> <p>Installation costs: Probe drilling with administration fee – EUR 3338 (EUR 333.8/kW), installation of the heat pump – EUR 258 (EUR 25.8/kW).</p> <p>For 130 m² family house with heat demand (heating and hot water) 8.5-9 kW:</p> <ul style="list-style-type: none"> • 500 l buffer tank, insulated, without exchanger – EUR 484 • 300 l indirect heating buffer tank for hot water, with exchanger – EUR 560 • 3-way valve – EUR 114 • 2 pc. circulating pump – EUR 111 				
D	<p>CAPEX for the heat pump assumed to be the same as ground source-heat pump, as the main difference between the two technologies is the heat collector.</p> <p>Additional investment assumed to be a well including a drilling of 50m (prices from SirAdos⁷⁴). Furthermore, a heat exchanger (prices from SirAdos) may be necessary, when the groundwater must be used indirectly.</p>				

⁷⁴ sirAdos-database for construction costs in Germany, www.baupreise.de, WEKA MEDIA GmbH & Co. KG, accessed September 2016, updated continuously.

Not many data are available for groundwater heat pumps. The improvements of COP and the reductions of CAPEX in 2030 and 2050 is based on IEA Technology Roadmap.⁷⁵

2.8.10 Datasheet

Please refer to the detailed datasheets in the spreadsheet at <http://data.europa.eu/89h/jrc-etri-techno-economics-smaller-heating-cooling-technologies-2017>

2.9 Heat pumps, electrical – electric ventilation heat pump (exhaust air heat pump)

2.9.1 Technical description

Ventilation heat pumps draw heat from ventilation exhaust air and uses it for heating up the air intake in the ventilation system. This type of heat pumps is also called exhaust air heat pumps.

The air can be heated to a level providing more heat than the ventilation heat loss, and thereby compensate for the transmission loss to some extent. But a ventilation heat pump will always need a supplementary heating system to cover the heat demand all year around and to make individual room regulation possible.

The heat pump can be combined with a heat exchanger that can exchange part of the heat from exhaust air to the intake air without any electrical input (other than electricity for the ventilators) since the exhaust air is warmer than the intake air. This will decrease the specific energy efficiency for the heat pump, but from a system perspective the efficiency will increase.

Some heat pumps also use the exhaust air heat for heating hot utility water. In this solution, the hot water production has first priority.



Figure 2-10: Electrical heat pump, ventilation⁷⁶

⁷⁵ Technology Roadmap, table 7, page 25, Technology Roadmap:

IEA Directorate of Sustainable Energy Policy and Technology, *Technology Roadmap – Energy-efficient Buildings: Heating and Cooling Equipment*, https://www.iea.org/publications/freepublications/publication/buildings_roadmap.pdf, 2011.

Different types of regulation exist for this type of heat pumps. There is on/off regulation and capacity regulation, which is continuously variable down to about 20 % of the maximum capacity. The best efficiency is obtained by a capacity regulation due to the lower supply temperature to the heat emitting system when the heat pump is running.

2.9.2 Current use and possible evolution (including best available technology and research)

Research and development

There are a number of areas where the performance of heat pumps can be improved by performing research and development activities.

Examples of possible improvements are:

- better control and operation strategies;
- adoption of heat pumps as a smart grid component;
- more efficient components;
- better integration with other systems as ventilation, water heating, space conditioning, storages and solar thermal systems.

2.9.3 Conditions/restrictions related to the use of the technology (indication of required investments for application in all types of buildings)

The EU Ecodesign regulation EU 813/2013 sets requirements for new heat pumps' energy efficiency used with water-based (hydraulic) heating systems as explained in Section 2.7.3.

Technical restrictions regarding the connected central heating system

Electric ventilation heat pumps are assessed to be suitable in any building with a central ventilation system.

2.9.4 Input and output (energy carriers)

Input

The input is the exhaust air from the building and electrical energy to drive the refrigerant cycling process.

Output

The output from ventilation heat pumps is heat for the air intake and in combined heat pumps also heat for hot tap water.

2.9.5 Typical capacities

The ventilation heat pumps range from 1.5 kW to several hundred kW in large office buildings. In private households, the capacity is normally up to 3 kW.

2.9.6 Advantages and disadvantages

The general advantage of the ventilation heat pump is that it uses the heat which would otherwise be lost to the surroundings through the exhaust air. Likewise, the heat pump is implemented in a system delivering fresh air in the building, which will improve the indoor climate.

⁷⁶ Energinet.dk; Danish Energy Agency. Technology Data for Individual Heat Production and Energy Transport. Copenhagen: Energinet.dk, 2012.

A ventilation system is necessary to implement the technology. In old houses with large uncontrolled ventilation due to air infiltration, the technology will not be applicable. In new and more airtight houses, ventilation systems are often applied, and here ventilation heat pumps will be a very good idea.

The disadvantage of ventilation heat pumps is that the heat input for the intake air is limited by the heat that can be drawn from the exhaust air. Because a building will have a larger heat loss than what is caused by ventilation (e.g. transmission heat loss) the heat pump will not be able to cover all of the heat demand, and a second heating system is normally needed.

2.9.7 Environmental considerations

Please refer to Section 1.2.3 for a general description of environmental considerations regarding heat pumps.

2.9.8 Applications with combinations of other technologies

As ventilation heat pumps only recover excess heat from buildings, another heating installation is required to cover the main part of the heat demand.

2.9.9 Indications of notable differences of techno-economic performance or applicability across Europe

Table 2-12: Techno-economic data for electric ventilation heat pumps. Comments on these data are provided in the table below.

	2.9 HP-e-ventilation	DK	PT	H	D
Small	Nominal heating/cooling capacity for one uni	2	3.6 / 2.5		2.5
	CAPEX (€/kW)	1 000	521		940
	CAPEX (€/unit)	2 000	1 875		2 350
	- hereof equipment (%)	90%	85%		90%
	- hereof installation (%)	10%	15%		10%
	Additional specific investment (€/unit)				
	Fixed O&M (€/unit/year)	150	60		120
	Variable O&M (€/unit/year)			234	
Large	Nominal heating/cooling capacity for one uni	200			25
	CAPEX (€/kW)	800			348
	CAPEX (€/unit)	160 000			8 700
	- hereof equipment (%)				95%
	- hereof installation (%)				5%
	Additional specific investment (€/unit)				
	Fixed O&M (€/unit/year)	450			120
	Variable O&M (€/GJ)				

DK	<p>According to Danish building regulation, buildings cannot be heated by ventilation air alone. An additional heat distribution system is required.</p> <p>Many ventilation heat pumps have hot tap water heating. This will decrease the heating of the ventilation intake air during colder hours, because of limitations in the heat pump capacity and be-cause these types of heat pumps have hot water priority.</p>
-----------	--

DK	<p>CAPEX represents the additional cost by including a ventilation heat pump in a new ventilation system with a passive heat exchanger. The price of the complete system including passive heat exchanger ducts and installation will be about EUR 8 000, where the installation costs will amount to approximately EUR 3 000.</p> <p>The installation part of the price is the added cost by having a ventilation heat pump in the system instead of just a ventilation system with passive heat exchange.</p> <p>The O&M cost corresponds to an expense of EUR 150 each year for one-family houses and three times more for apartment buildings.</p>
PT	<p>Division of CAPEX in equipment and installation costs is assumed the same as the air-to-air heat pump.</p> <p>For electric heat pumps, the emissions depend on how the electricity is produced. Emission factors for electricity in Portugal can for instance be found in socio-economic assumptions for energy projects published by IEA⁷⁷.</p>
H	There is no electric ventilation heat pump market in Hungary
D	Costs estimated at connection to existing ventilation system, further expenses for the ventilation system may apply.

The improvements of COP and the reductions of CAPEX in 2030 and 2050 is based on Danish data and IEA Technology Roadmap.⁷⁸

2.9.10 Datasheet

Please refer to the detailed datasheets in the spreadsheet at <http://data.europa.eu/89h/jrc-etri-techno-economics-smaller-heating-cooling-technologies-2017>

2.10 Gas driven heat pumps – direct fired absorption heat pump air/brine to water

Absorption heat pumps are a category of thermally driven heat pumps, which can be categorised in the three subcategories 1) direct-fired gas driven 2) hot water driven and 3) steam driven. Hence, indirect fired heat pumps can have other heat sources than gas. This technology description focuses on direct-fired absorption heat pumps.

2.10.1 Technical description

Gas-fired absorption heat pumps are thermally driven heat pumps, using gas as drive energy for the absorption process. The gas may also be used as heat source on the cold side of the heat pump. This differentiates them from engine- or electrical driven

⁷⁷ IEA, *CO₂ Emissions from Fuel Combustion – Highlights*, <https://www.iea.org/publications/freepublications/publication/CO2EmissionsFromFuelCombustionHighlights2015.pdf>, 2015.

⁷⁸ Technology Roadmap, table 7, page 25, Technology Roadmap:

IEA Directorate of Sustainable Energy Policy and Technology, *Technology Roadmap – Energy-efficient Buildings: Heating and Cooling Equipment*, https://www.iea.org/publications/freepublications/publication/buildings_roadmap.pdf, 2011.

compressor heat pumps. The heat from gas is typically produced with a full premix burner.

Gas heat pumps can deliver water temperatures above 55°C, and thus deliver hot tap water and in this case use lower radiator size designed for high water temperature. Note, however, that in this last case, the efficiency may decrease when the water temperature in the heating system increases.

Gas heat pumps can be used with natural gas and LPG (Liquefied Petroleum Gas), but also with new "green gases" like biogas. Appliances that are certified for natural gas can cope with a large variation of natural gas specifications, including natural gas/upgraded biogas mix as long as the specifications of the mixture conform to specifications of the natural gas. Note that upgraded biogas mostly contains methane and may therefore be used directly (without mixing with natural gas = 100 %).

The basic absorption cycle is shown in Figure 2-11. In the basic absorption process, ammonia is evaporated by the free energy (e.g. ambient air) and flows to an absorber, where it forms a solution with water. Heat is generated and transferred from the absorber to the heating system. The ammonia-water solution is pumped at increased pressure to the generator where heat is added through for example a gas burner. The ammonia vapour formed in the generator flows to the condenser, where it is condensed and energy is transferred to the heating system. A lean ammonia-water solution recirculates from the generator to the absorber. Liquid ammonia flows after a pressure reduction from the condenser to the evaporator where it is vaporized again.

This basic principle can be direct and in-direct fired, both using heat energy as drive energy but direct fired defined as being within the system boundary (in this case gas consumption). The heat pump/chiller can be two-stage (or more) operating at different temperature levels.

Other refrigerants are possible in the absorption process, but ammonia-water is the preferred in heat pumps for space heating.

The heat which the burner produces triggers various physical processes in the closed circuit of the gas heat pump - in contrast to an electric heat pump or gas engine driven heat pump, no compressor is needed.

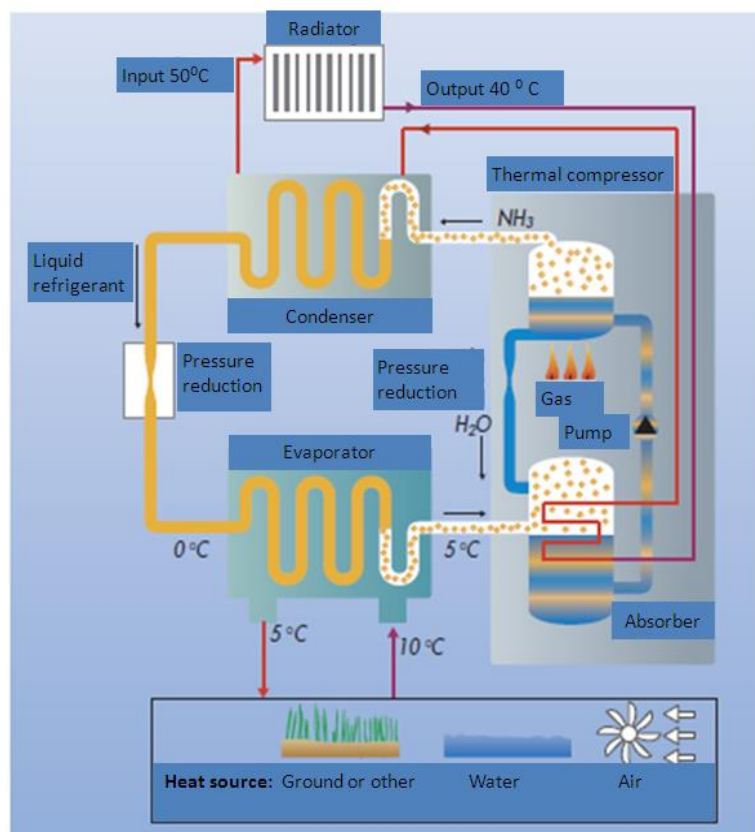

Figure 2-11 Operating principle for gas absorption heat pump⁷⁹

In the EU, there are already about 45 000⁸⁰ gas absorption heat pumps installed.

Different types of regulation (for the load control) exist for heat pumps. Appliances can either work in on/off mode or in modulating mode. The typical modulation range from current technologies of gas absorption heat pumps is 50-100 %.

2.10.2 Current use and possible evolution (including best available technology and research)

Research and development

The practical capacity range of absorption heat pumps for space heating has increased since the introduction of the Robur appliance (described under Examples of Best Available Technology) around 2005. Absorption heat pumps are suitable for single-family houses as well as apartment blocks. For single-family houses the output capacity will be 10-15 kW, and for larger heating demands in for example apartments blocks and the commercial sector, one or several 44 kW Robur heat pumps in a cascade configuration can be applied.

⁷⁹ ASUE, Gas Heat Pumps (German title Gaswärmepumpen), Brochure, 2002, http://asue.de/sites/default/files/asue/themen/gaswaermepumpe_kaelte/2002/broschueren/06_12_02_g_w_pump.pdf, translated by:

Energinet.dk; Danish Energy Agency. Technology Data for Individual Heat Production and Energy Transport. Copenhagen: Energinet.dk, 2012

⁸⁰ GasTerra. Gas Heat Pumps. Efficient Heating and Cooling with Natural Gas. Groningen: Castel International Publishers, 2010.

Absorption heat pump technology could be suitable for houses with very low heat demand but, due to the present costs of the technology and installation, the market for passive houses or low-energy houses is rather limited. One challenge for the technology is to further reduce the lower capacity limit.

Currently, mainly larger appliances (40+ kW) are available for potential consumers. Smaller appliances are in the focus of technological development.

We are still in an early stage of utilization of all kinds of gas heat pumps. Gas absorption heat pumps are currently available from approximately 18 kW output, with the typical application of absorption heat pumps being in larger applications.

Examples of best available technology

The Robur E³ appliances are gas-fired absorption heat pumps with modulating output and flue gas condensation. They have an output in the range of 18 – 44 kW (modulating) depending on the version of the model. The burner is a premixed burner of the same basic design as in modern condensing gas boilers.

The heat pump is available in two options, as an air-to-water or ground-to-water heat pump.



Figure 2-12 Robur E3 heat pump. Air-to-water (left) and ground source options⁸¹

The Robur heat pumps mentioned in the present document is presently sold on the market under several brand names, including Buderus, Remeha, Oertli.

2.10.3 Conditions/restrictions related to the use of the technology (indication of required investments for application in all types of buildings)

The EU Ecodesign regulation EU 813/2013 sets requirements for new heat pumps' energy efficiency used with water-based (hydronic) heating systems as explained in Section 2.7.3. The regulation also sets limits to No_x emissions for new equipment from 26. September 2018.

Technical restrictions regarding the connected central heating system

The currently available appliances of absorption heat pumps are a suitable alternative for mainly natural gas supplied buildings. If the product range is expanded to other

⁸¹ Energinet.dk; Danish Energy Agency. Technology Data for Individual Heat Production and Energy Transport. Copenhagen: Energinet.dk, 2012.

fuels like solid biomass, the technology may also become suitable for buildings off the natural gas distribution grids. As the efficiency of absorption heat pumps is not as sensitive to high flow temperatures on the warm side, absorption heat pumps are suitable for all buildings with a central, water-based heating system and do not require expansion of radiator capacity etc.

2.10.4 Input and output (energy carriers)

Input

The input is the heat from e.g. ambient air or the top soil/ground collected by the outdoor heat exchanger or ground collector (vertical or horizontal). Gas is needed to drive the process. The heat can also be combined with other "free" energy sources like solar or sewage water.

Output

The output is thermal energy for space heating and hot water. In case of reversible heat pumps, the output is also cooling.

2.10.5 Typical capacities

Typical capacities for absorption heat pumps for domestic use are 18-44 kW_{th}.⁸² In principle, the absorption process is reversible, i.e. all heat pumps should be capable of reversing. In practise, not all models available today are fitted to be reversible.

Earlier absorption heating and cooling models had up to several MW heating capacity. Larger absorption machines up to MW size that have been produced for several years are out of scope of this catalogue.

2.10.6 Regulation ability (electricity)

Only relevant for electricity driven technology.

2.10.7 Advantages and disadvantages

Advantages

- The absorption gas heat pump technology is already a mature product with high efficiency in the capacity range 18-44 kW. Currently, 18 kW is the smallest capacity freely available at market conditions.
- It is adapted for the replacement of existing boilers (minimal change of existing system) and suitable for buildings with radiators that might require higher temperatures.

Disadvantages

- There is basically only one product on the market (Robur; note that the appliances are sold on different markets under different names).

The "low" efficiency of approximately 170 % is not considered a disadvantage of absorption HPs, because the primary energy consumption/factor is of higher relevance. Thus, the efficiency of absorption heat pumps is considered as fuel efficiency (%) and not COP. The technology is rather an improved natural gas boiler (due to it still being dependant on NG) than being a fuel and combustion free heat pump.

⁸² Robur, Company Homepage, *K18 Condensing Absorption Heat Pump Powered by Gas and Air Source Renewable Energy*
http://www.robur.com/heat_pumps/gas_absorption_heat_pump_for_homes_k18, accessed June 2016.

2.10.8 Environmental considerations

Using ammonia and water as refrigerants, the environmental considerations regarding the refrigerant are very limited.

When using ambient air as heat source, the part placed outside is a source of noise.

2.10.9 Applications with combinations of other technologies

2.10.10 Indications of notable differences of techno-economic performance or applicability across Europe

Table 2-13: Techno-economic data for gas driven heat pumps, air brine water. Comments on these data are provided in the table below.

	2.10 GHP-a-air-brine-water	DK	DK	PT	H	D
Small	Nominal heating/cooling capacity for one uni	18	18	18		
	CAPEX (€/kW)	722	867	-		
	CAPEX (€/unit)	13 000	15 600			
	- hereof equipment (%)	77%	64%			
	- hereof installation (%)	23%	36%			
	Additional specific investment (€/unit)	2 000	6 400			
	Fixed O&M (€/unit/year)	240	135			
	Variable O&M (€/GJ)	2	2			
Large	Nominal heating/cooling capacity for one uni	44	44		35	38
	CAPEX (€/kW)	409	750		400	761
	CAPEX (€/unit)	18 000	33 000		14 000	28 900
	- hereof equipment (%)	78%	42%			95%
	- hereof installation (%)	22%	58%			5%
	Additional specific investment (€/unit)	1.6	24.6			
	Fixed O&M (€/unit/year)	240	135		30	155
	Variable O&M (€/GJ)	2	2			

DK	CAPEX is split as following: Appliance + Installation of appliance + Heat collectors brine (when relevant). The cost of appliance in 2015 is difficult to appreciate as the technology is not yet on the market. However, considering the cost of the same technology sold today to commercial users (see next table) it is fair to think that the cost of the appliance alone will be around 10.000EUR to start with; the target price once the appliance is on the market would be about EUR 7-9 000 decreasing with time as production increases.
PT	
H	Only one imported product could be found on the market. Brand: Remeha. The price of the whole equipment is EUR 400/kW, which includes the price of the installation. According to the expert of the Remeha Company, around 10 % is the price of the installation. According to the expert of the Remeha Company, the O&M cost is the same as in the case of the air-to-air heat pump.

D	Only one appliance (Robur) found as market ready technological solution, marketed by different suppliers. At 38 kW at ambient air T of +7°C, 31.5 kW at T of -7°C, T_{flow} constantly 50°C it is considered a medium-large appliance. No expenditure for thermal storage included.
----------	---

For the projected data, increased efficiency, reduced emissions and reduced CAPEX is expected. This is based on the Danish data. Hence, the expected relative development is applied also for the other countries.

2.10.11 Datasheet

Please refer to the detailed datasheets in the spreadsheet at <http://data.europa.eu/89h/jrc-etri-techno-economics-smaller-heating-cooling-technologies-2017>

2.11 Gas driven heat pumps – adsorption heat pump brine to water

2.11.1 Technical description

Gas adsorption heat pumps are thermally driven heat pumps, which use gas as energy source to drive the heat pump process. The heat from gas is typically produced with a full pre-mix burner.

In adsorption processes, the water, which is mainly used as the refrigerant, evaporates, and in this process it absorbs the ambient heat.

The water vapour is adsorbed on the surface of a solid substance, such as active charcoal, silica gel (glass-like silicates) or zeolite, (such as the Viessmann and Vaillant appliances). Alternative solid-sorption systems such as solid-ammonia, salt-ammonia, LiCl-H₂O are also used⁸³.

Thus, heat is released at a higher temperature. Once the zeolite is saturated, the water is driven out of the zeolite again in the desorption phase. Heat from a gas burner is used for this purpose.

The adsorption heat pump process is a non-continuous regenerative and periodic process. The adsorption heat pump consists of an adsorbent, a heat exchanger and a heat generator (burner). In the desorption phase, heat from the gas burner vaporizes water adsorbed in the adsorbent. The water vapour condenses in the heat exchanger, which in this phase is connected to the heating system. Heat is released during the adsorption and transferred to the heating system.

The heat which the burner produces triggers various physical processes in the closed circuit of the gas heat pump - in contrast to an electric heat pump or gas engine driven heat pump, no compressor is needed.

Current adsorption heat pumps only use energy source with temperatures above 2-3 °C, i.e. ground source or solar collectors.

⁸³ Gas Heat Pumps. Efficient heating and cooling with natural gas. GasTerra / Castel International Publishers. Groningen, Netherlands. 2010

2.11.2 Current use and possible evolution (including best available technology and research)

Research and development

As mentioned, adsorption heat pumps with zeolites/water require a source temperature above 2-3 °C. A wider temperature range will increase the market potential. Adsorption heat pumps for the commercial sector are not available today.

Examples of best available technology



Figure 2-13 Vaillant zeoTHERM adsorption heat pump, using energy from solar heating.⁸⁴

The first market-available adsorption heat pump for residential use in Europe was the Vaillant ZeoTherm. It is delivered in a package with a storage tank and solar collectors as seen in Figure 2-13. The technical data from the manufacturer⁸⁵ describes a standard package system including 1.16 m² solar collector. The system can also be used with more options and up to 2.4 m² of solar collectors in alternative packages. The water tank volume is 390 l. The solar collectors not only add energy to the heat pump, but also to hot water and heating in the same manner as a boiler and solar collector combination.

Zeolite/water requires a source temperature above 2-3 °C; if not achievable with solar, gas will be used. Vaillant claims an overall efficiency of 135 % (nominal net efficiency) for a 40/30 °C heating system and additional 10 % solar energy contribution, resulting in the overall system efficiency around 145 %⁸⁶. The heat pump is modulating in the 1.5-10 and 1.5-15 kW ranges, depending on the model. The maximum supply temperature is 75°C, but a maximum of 40°C is recommended. Test results⁸⁷ are claiming 113 to 122 % annual efficiency (without solar) and 133 to 144 % annual efficiency (with solar).

⁸⁴ Energinet.dk; Danish Energy Agency. Technology Data for Individual Heat Production and Energy Transport. Copenhagen: Energinet.dk, 2012.

⁸⁵ Vaillant Data: zeoTHERM Zeolith-Gas-Wärmepumpe. Bedienungsanleitung, Vaillant 2012 and Zeolith-Gas-Wärmepumpe zeoTHERM, Vaillant sales pamphlet, 2012.

⁸⁶ Vaillant Data: zeoTHERM Zeolith-Gas-Wärmepumpe. Bedienungsanleitung, Vaillant 2012 and Zeolith-Gas-Wärmepumpe zeoTHERM, Vaillant sales pamphlet, 2012

⁸⁷ EONRG, *Potential of the Gas-Heat-Pumps*, GHP workshop. Paris, December 2011

Viessmann has introduced a similar product, the VITOSORP 200-F. It is a combined natural gas-fired adsorption heat pump and condensing natural gas boiler. The condensing boiler is installed for peak loads. The VITOSORP can be combined with a solar thermal unit to operate in similar ways as the Vaillant appliance.

Different types of regulation (for the load control) exist for heat pumps. Appliances can work in either on/off mode or in modulating mode. The modulation range for gas adsorption driven heat pumps is approximately 20-100 %

2.11.3 Conditions/restrictions related to the use of the technology (indication of required investments for application in all types of buildings)

The EU Ecodesign regulation EU 813/2013 sets requirements for new heat pumps' energy efficiency used with water-based (hydronic) heating systems as explained in Section 2.7.3. The regulation also sets limits to NO_x emissions for new equipment from 26. September 2018.

Technical restrictions regarding the connected central heating system

The current applications of adsorption heat pumps are designed to use natural gas as drive energy and hence, a natural gas grid connection must be available. Furthermore, it must be possible to install either a ground heat collector or solar thermal collector to secure heat input of at least 2°C.

Adsorption heat pumps can supply heat at up to 75°C, but the existing suppliers recommend not exceeding 40-55°C in general operation. This may be too low for older, existing central heating systems. This may be addressed by increasing the radiator capacity, or by increasing the level of insulation of the building.

2.11.4 Input and output (energy carriers)

Input

The input is the heat collected by the outdoor ground collector (vertical or horizontal), and gas is needed to drive the process. The product on the market also proposes solar panels to have an energy source above 2-3°C.

Output

The output is thermal energy for space heating and hot water. In case of reversible heat pumps, the output is also cooling.

2.11.5 Typical capacities

Gas adsorption heat pumps available on the market are designed for the domestic market. Current applications are in the range of 15 kW, i.e. designed for single-family houses. They are often combined with a natural gas-fired boiler for peak and backup and possibly temperature boosts.

2.11.6 Regulation ability (electricity)

Only relevant for electricity consuming technologies.

2.11.7 Advantages and disadvantages

Advantages

- Nowadays, gas adsorption driven heat pumps are designed by the gas boiler manufacturers, so the one-to-one replacement with existing gas boiler is simple and easy.

- Gas adsorption heat pumps use refrigerants with no global warming impact (ammonia/water refrigerant). Current gas adsorption heat pumps use zeolites and water.

Disadvantages

- The source energy is limited to ground or solar collectors due to the lower temperature limit of approximately 2°C. This is the reason why it is often combined with solar energy. If not, the piping must be deep enough to guarantee that this requirement is respected.
- Currently, the technology seems to have slightly lower efficiency compared to the two other gas heat pump technologies.
- The technology is very new with the disadvantages that this implies, e.g. few solutions available on the market and lack of knowledge on reliability.
- Today, the appliance does only exist for the domestic sector.

2.11.8 Environmental considerations

Gas adsorption heat pumps use a refrigerant, which is not harmful for the ozone layer.

2.11.9 Applications with combinations of other technologies

2.11.10 Indications of notable differences of techno-economic performance or applicability across Europe

Table 2-14: Techno-economic data for gas adsorption heat pumps, brine/water. Comments on these data are provided in the table below.

	2.11 GHP-ad-brine-water	DK	PT	H	D
Small	Nominal heating/cooling capacity for one unit (kW)	15	-	-	25
	CAPEX (€/kW)	933			780
	CAPEX (€/unit)	14 000			19 496
	- hereof equipment (%)	71%			95%
	- hereof installation (%)	29%			5%
	Additional specific investment (€/unit)	1 600			9 450
	Fixed O&M (€/unit/year)	135			272
	Variable O&M (€/GJ)	100			

DK	Appliance cost = EUR 10 000. Manufacturer data from www.glo24.eu , confirmed by E.ON Ruhrgas. The prices are, however, for the German market and include the appliance, a hot-water tank, the solar collectors and the system control. The installation cost will be similar to the other heat pumps technologies (EUR 4 000)
PT	
H	There is no gas driven heat pumps – adsorption heat pump brine to water market in Hungary.
D	The hot tap water demand is covered by the solar thermal system, when not needed to produce heat for the adsorption heat pump. 12 person-hours for installation of solar thermal collectors. 12.5 person-hours for the heat pump and commissioning. Optional horizontal ground source thermal collectors.

2.11.11 Datasheet

Please refer to the detailed datasheets in the spreadsheet at <http://data.europa.eu/89h/jrc-etri-techno-economics-smaller-heating-cooling-technologies-2017>

2.12 Gas driven heat pumps – gas engine driven heat pump air/brine to water

2.12.1 Technical description

A gas engine heat pump uses the same heat pump process as the electric heat pump, but the compressor is operated by a gas engine instead of an electric motor. Heat is also recovered from the engine cooling and the flue gases. In principle, any gas can be used in the gas engine. Natural gas, upgraded (or not) biogas, LPG and hydrogen are possible.

Essentially, the heat pump comprises four components: the compressor, the condenser, the expansion valve and the evaporator.

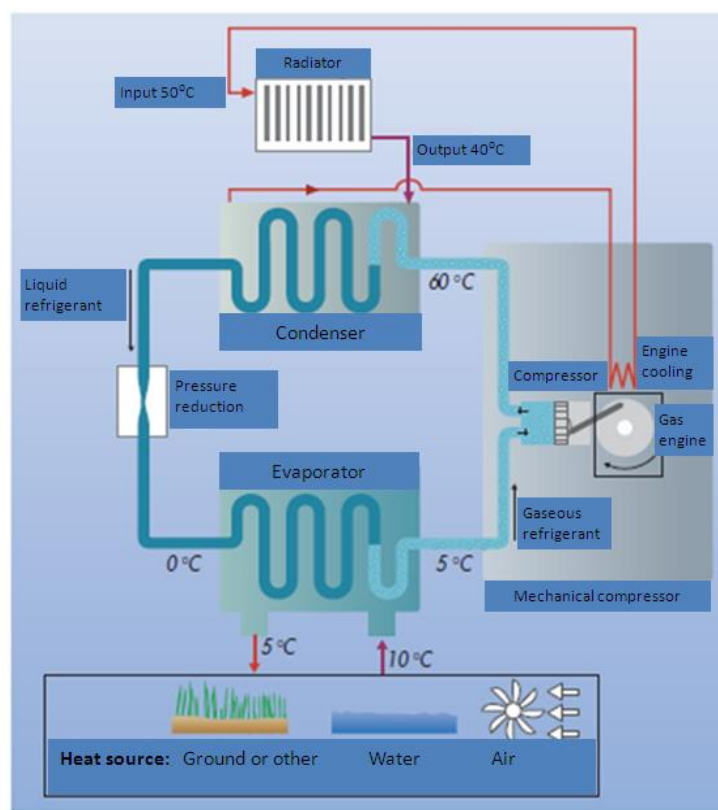

Figure 2-14: Operating principle for gas engine driven heat pump⁸⁸

⁸⁸ ASUE, Gas Heat Pumps (German title Gaswärmepumpen), Brochure, 2002, http://asue.de/sites/default/files/asue/themen/gaswaermepumpe_kaelte/2002/broschueren/06_12_02_g_w_pump.pdf, translated by:

Energinet.dk; Danish Energy Agency. Technology Data for Individual Heat Production and Energy Transport. Copenhagen: Energinet.dk, 2012

Different types of regulation (for the load control) exist for heat pumps. Appliances can either work in on/off mode or in modulating mode. The percentage of the maximum capacity depends on the technology and model considered.

The typical modulation ranges for gas engine driven heat pumps is approximately 30-100 %.

2.12.2 Current use and possible evolution (including best available technology and research)

The number of installed appliances in the EU is approximately 10 000 (2012) /17/.

Even though this technology exists for larger heat/cooling demand (e.g. engine driven Aisin and Sanyo), the market for smaller gas engine driven heat pumps is still small. The smallest currently (2016)⁸⁹ available appliance is Japanese manufacturer Aisin's, working with a Toyota engine. It has a min. thermal heat effect of 25 kW and is thus still to be seen as a larger appliance for multifamily houses or the commercial sector.

Research and development

One of the issues of engine based heat pumps are NO_x-emissions. R&D to decrease those would help the technology to better penetrate the market.

Examples of best available technology

Gas engine driven heat pump.



Figure 2-15: Aisin produces gas engine driven air to water heat pumps⁹⁰

A typical gas heat pump air conditioner from Aisin is a gas engine driven air-to-water heat pump, which provides both cooling (22-71 kW) and heating (25-80 kW). Air-to-

⁸⁹ ASUE (German Sector Organisation for Energy Efficient Gas Technologies), Information Homepage regarding market-available gas-heat pump technologies, <http://asue.de/wer-bietet-an#gasmotor-waermepumpen>, accessed November 2016.

⁹⁰ Energinet.dk; Danish Energy Agency. Technology Data for Individual Heat Production and Energy Transport. Copenhagen: Energinet.dk, 2013.

air and air-to-water technologies are commercially available. Cascade solutions are possible for up to 6 units.

In general, the gas engine driven heat pump will need an ordinary maintenance every approximately 10 000 hours of operation and oil change for every 30 000 hours.

2.12.3 Conditions/restrictions related to the use of the technology (indication of required investments for application in all types of buildings)

The EU Ecodesign regulation EU 813/2013 sets requirements for new heat pumps energy efficiency used with water-based (hydronic) heating systems as explained in Section 2.7.3. The regulation also sets limits to NO_x emissions for new equipment from 26th September 2018.

Technical restrictions regarding the connected central heating system

Gas engine driven heat pumps require a supply of gas, e.g. a connection to the natural gas grid. Depending on the chosen heat source, there may also be a space demand for heat collectors.

The desirable temperatures for supply are similar to those of adsorption heat pumps, thus limiting the suitability of gas engine heat pump to heat sinks with a flow temperature of approximately 50°C or less.⁹¹

2.12.4 Input and output (energy carriers)

Input

The input is the heat from e.g. ambient air collected by the outdoor heat exchanger or ground collector (vertical or horizontal). Gas is needed to drive the engine. The waste heat in the flue gases can be used as heat source for the heat pump too. The heat can also be from e.g. solar or sewage water.

Output

The output is thermal energy for space heating and hot water. In case of reversible heat pumps, the output is also cooling. In a gas engine heat pump, it is also possible to add a generator for production of electricity (tri-generation, e.g. Sanyo).

2.12.5 Typical capacities

For gas engine driven heat pump, the scale ranges from approximately 25 kW to a few MW mechanical capacity. Heat pumps on the scale of MW are usually specially designed for a specific situation. The capacity range of multi-split units is 30 kW to 90 kW for heating and 20 kW to 70 kW for cooling. The technology of outdoor units based on gas engine-driven compression heat pumps is now fully mature. Outdoor units can easily be connected in cascade to achieve larger capacities (up to 1 000 kW)⁹².

2.12.6 Regulation ability (electricity)

Different types of regulation (for the load control) exist for heat pumps. Appliances can either work in on/off mode or in modulating mode. The percentage of the maximum capacity depends on the technology and model considered.

⁹¹ Schwank GmbH & Yanmar, Datasheet for gas-engine heat pumps, http://www.schwank.de/fileadmin/00_customer/documents/pdf/Brosch%C3%BCren_DE/Gasw%C3%A4rmepumpe_Datenblatt.pdf

⁹² GasTerra. Gas Heat Pumps. Efficient Heating and Cooling with Natural Gas. Groningen: Castel International Publishers, 2010.

The typical modulation ranges for gas engine driven heat pumps is approximately 30-100 %.

2.12.7 Advantages and disadvantages

Advantages

- The gas engine driven gas heat pump technology is already mature.
- Gas engine heat pumps are preferable (to other gas driven heat pumps) when cooling is the main requirement because of their higher efficiency when cooling⁹³.

Disadvantages

- There are only few market-ready appliances for the domestic sector. (The appliances are mostly designed for offices, hostels, hospitals and not for the domestic sector).
- Noise from the engine may be an issue; but manufacturers (Sanyo, etc.) are making an effort to produce more silent appliances.
- The investment and maintenance cost of the product are higher than electrical heat pumps (2012)⁹⁴.
- The technology is not very well known by users or professionals and standards not yet ready (2012)⁹⁵.

2.12.8 Environmental considerations

Engine driven heat pumps are using the same refrigerants as electrical heat pumps⁹⁶. Hence, the environmental considerations regarding the refrigerants as stated in Section 1.2.3 also apply for engine driven heat pumps.

Furthermore, there is an emission of NO_x from the engine.

⁹³ Gas Heat Pumps. Efficient heating and cooling with natural gas. GasTerra / Castel International Publishers. Groningen, The Netherlands. 2010

⁹⁴ EONRG, Potential of the Gas-Heat-Pumps, GHP workshop. Paris, December 2011

⁹⁵ EONRG, Potential of the Gas-Heat-Pumps, GHP workshop. Paris, December 2011

⁹⁶ Energinet.dk & Danish Energy Agency: Technology data for individual heat production and energy transport. 2012

2.12.9 Indications of notable differences of techno-economic performance or applicability across Europe

Table 2-15: Techno-economic data for gas driven heat pumps, air/brine to water.

	2.12 GHP-eng-airbrine-water	Air-water Air-brine				
		DK	DK	PT	H	D
Small	Nominal heating/cooling capacity for one unit (kW)					
	CAPEX (€/kW)					
	CAPEX (€/unit)					
	- hereof equipment (%)					
	- hereof installation (%)					
	Additional specific investment (€/unit)					
	Fixed O&M (€/unit/year)					
	Variable O&M (€/GJ)					
Large	Nominal heating/cooling capacity for one unit (kW)	80	80			
	CAPEX (€/kW)	18	18			
	CAPEX (€/unit)	1 400	1 400			
	- hereof equipment (%)	83%	51%			
	- hereof installation (%)	17%	49%			
	Additional specific investment (€/unit)	2	23			
	Fixed O&M (€/unit/year)	135	135			
	Variable O&M (€/GJ)	2	2			

There is no gas driven heat pumps – gas engine driven heat pump air/brine to water market in Hungary.

In the Danish catalogue, increased efficiency and technical lifetime is assumed for the future development.

2.12.10 Datasheet

Please refer to the detailed datasheets in the spreadsheet at <http://data.europa.eu/89h/jrc-etri-techno-economics-smaller-heating-cooling-technologies-2017>

2.13 Gas driven heat pumps –gas engine groundwater

2.13.1 Technical description

Gas engine driven heat pumps have traditionally been used for air-to-air appliances, primarily in Japan. As many European buildings have water based heat distribution systems, gas engine driven air-to-water heat pumps were the first major application of gas engine driven heat pumps in Europe, cf. the Aisin-appliance⁹⁷ that is described in Section 2.12. The basic principle of gas engine driven groundwater heat pumps is the same as the one described in Section 2.12 “Gas driven heat pumps – gas engine driven heat pump air/brine to water”. The considerations regarding using groundwater as a heat source are in principle the same as the ones elaborated in 2.8 “Heat pumps, electrical – groundwater”, i.e. caution must be paid when utilizing groundwater for energy purposes and the pre-study and drilling extent will most likely only create feasible solutions in large-scale applications.

⁹⁷ Yanmar has a similar product, that is available in i.e. Germany.

Water-based gas engine heat pumps are a technical alternative to other water-based heat pump technologies. A report by Dutch GasTerra⁹⁸ assesses, that groundwater will form an obvious choice as heat source in future gas engine driven heat pumps. However, for now, the concept is still under development. However, no market ready appliances exist yet, as the appliances using air as the heat source, have been the driving factor for the technological development.

2.14 CHP engines – micro turbine

Micro-CHP is relevant for meeting a heating as well as an electricity demand. Typically, the heat demand is the key design parameter. The system can reach high efficiencies, if both heat and electricity are utilized. Due to the decentralised production, heat losses are minimised compared to district heating systems.

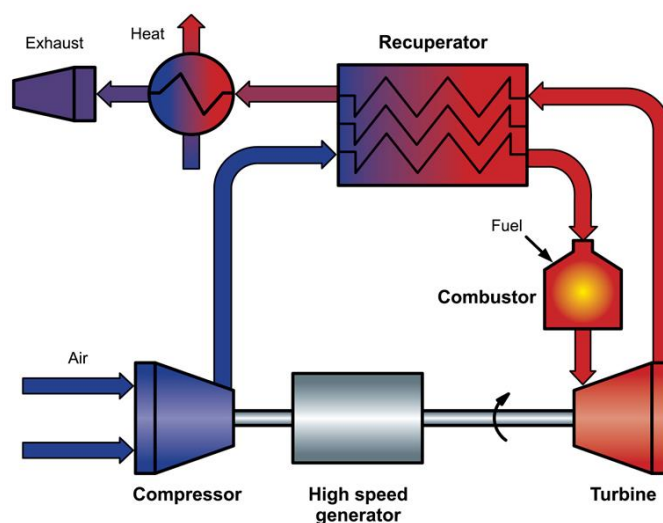

Figure 2-16: Basic principle of a micro turbine.⁹⁹

The basic functioning of a micro turbine is illustrated in Figure 2-16. Ambient air is injected and pressurized in the compressor. The compressed air is pre-heated in the recuperator. In the combustion chamber, heat is generated by the combustion of a fuel. The hot pressurized gas expands in the turbine, providing mechanical power for both the compressor and the generator. An "inverter" converts the power supplied by the generator to the voltage and frequency of the main electricity grid (230V / 50Hz). The expanded gas after the turbine heats the air compressed by the compressor in the recuperator. The residual heat still present in the recuperator outlet gas is transferred in the heat exchanger to water. The hot water is used for central heating and/or as hot tap water.¹⁰⁰

Typical micro turbine efficiencies are 25 to 35 %. When in a combined heat and power cogeneration system, efficiencies of greater than 80 % are commonly achieved.

⁹⁸ GasTerra. Gas Heat Pumps. Efficient Heating and Cooling with Natural Gas. Groningen: Castel International Publishers, 2010.

⁹⁹ Enertwin, Company Homepage, <http://www.enertwin.com/enertwin-en/the-micro-turbine-technology>, downloaded December 17th 2016.

¹⁰⁰ EnerTwin, Company Homepage, Technical Description of MicroTurbine. Accessed throughout November 2016.

However, in order to be considered highly efficient, the efficiency requirement is 100 %, cf. section 2.14.3 below.

2.14.1 Technical description

Basic principles of micro turbine are based on micro combustion (small-scale flames whose physics is qualitatively different from conventional flames). See above figure and description.

2.14.2 Current use and possible evolution (including best available technology and research)

Research and development

A separate development program has been started for development of a clean combustor for liquid fuels that will comply with future emission requirements.

The ERA-LEARN 2020 project MTT_MICRO_CHP (2011-2014)¹⁰¹ focused on R&D of high tech components for a 3 kWe micro turbine based micro-CHP system with the objective of optimising the efficiency. The project result included the development of a compact, high temperature recuperator for a very small Brayton gas turbine cycle including the methodology to produce it, as well as prototypes and tests.

Examples of best available technology

Examples of suppliers include:

- MTT (Micro Turbo Technology BV), <http://www.mtt-eu.com/>
- Green Turbine, <http://www.greenturbine.eu/MicroCHP.html#>
 - 1.5 kW, EUR 5 250, additional specific investments EUR 3 439, 13 kW steam boiler required
 - 15 kW, EUR 16 000, additional specific investments EUR 23 000, 150 kW steam boiler required.
- EnerTwin – heat and power, <http://www.enertwin.com/>
- Capstone, <http://www.capstoneturbine.com/solutions>
 - 30 kW (smallest unit)
- Samad Power, <http://www.samad-power.co.uk/wp/micro-turbin-chp/>
 - Includes a video of demonstration of operation

2.14.3 Conditions/restrictions related to the use of the technology (indication of required investments for application in all types of buildings)

The EU Ecodesign regulation EU 813/2013 sets requirements for new cogeneration units below 50 kW(electric) of 86 %, as seasonal efficiency from primary energy and reduced by accounting for temperature controls as explained in Commission Communication in Official Journal C 207. From 26. September 2017 this efficiency requirement will be increased to 100 %

The same regulation also sets efficiency requirements for the hot tap water supply function, if it is included. The energy efficiency requirements depend on the size (tapping capability) of the water heating function.

¹⁰¹ ERA-Learn 2020, Project Homepage, *High-Tech Components for MTT Micro Turbine Based Micro-CHP*, <https://www.era-learn.eu/network-information/networks/eurostars/eurostars-programme/high-tech-components-for-mtt-micro-turbine-based-micro-chp>, accessed December 2016.

2.14.4 Input and output (energy carriers)

Input

The micro-CHP can utilize a wide range of fuels including natural gas, propane, heating oil and biogas.

While natural gas is the fuel choice for the domestic micro-CHP application, liquid fuels such as heating oil or diesel are required at locations without access to a natural gas distribution grid.

However, when running on kerosene or diesel, starting sometimes requires the assistance of a more volatile product such as propane gas - although the new kero-start technology can allow even micro turbines fuelled on kerosene to start without propane.

Output

The output is electricity as well as heat for space heating and for hot tap water production. The electricity produced can be consumed in the building or in case the electricity production exceeds the demand it can be exported to the electrical grid (national regulation regarding feed-in-tariffs may vary).

2.14.5 Typical capacities

Range from hand held units producing less than a kilowatt, to commercial sized systems that produce tens or hundreds of kilowatts.

Typical heat capacities for micro turbines are from 2 kW. Typical electrical capacities are from 1-180 kW.

2.14.6 Regulation ability (electricity)

2.14.7 Advantages and disadvantages

Compared to reciprocating engine generators, the advantages of micro-turbine systems include higher power-to-weight ratio and few moving parts.

However, reciprocating engine generators are quicker to respond to changes in output power requirement and are usually slightly more efficient, although the efficiency of micro turbines is increasing. Micro turbines also lose more efficiency at low installed capacity levels than reciprocating engines. There may be other disadvantages, for instance decrease in efficiency with higher ambient temperature.

Reciprocating engines are still cheaper considering total investment and operation.

2.14.8 Environmental considerations

Micro turbines may be designed with foil bearings and air-cooling operating without lubricating oil, coolants or other hazardous materials.

Lower emissions compared to internal combustion engines.

Lower emissions, and thus higher efficiencies, are also enabled by the construction. Micro turbines have the majority of the waste heat contained in the relatively high temperature exhaust making it simpler to capture, whereas the waste heat of reciprocating engines is split between its exhaust and cooling system.

2.14.9 Applications with combinations of other technologies

Micro turbine is not widely applied. The technology is appropriate for meeting an electricity as well as a heating demand. Supplementary heat production capacity

and/or heat storage would be relevant. Supplementary heat production could be a boiler.

2.14.10 Indications of notable differences of techno-economic performance or applicability across Europe

Table 2-16: Techno-economic data for CHP engine, micro turbine. Comments on these data are provided in the table below.

	2.14 CHP-eng-micro-turbine	DK	PT	H	D
Small	Nominal heating/cooling capacity for one unit (kW)	-	-	30	
	CAPEX (€/kW)			3 466	
	CAPEX (€/unit)			103 980	
	- hereof equipment (%)			88%	
	- hereof installation (%)			12%	
	Additional specific investment (€/unit)				
	Fixed O&M (€/unit/year)				
	Variable O&M (€/GJ)				
Large	Nominal heating/cooling capacity for one unit (kW)	-	-	200	-
	CAPEX (€/kW)			1 375	
	CAPEX (€/unit)			275 000	
	- hereof equipment (%)				
	- hereof installation (%)				
	Additional specific investment (€/unit)				
	Fixed O&M (€/unit/year)				
	Variable O&M (€/GJ)				

H	<p>There is no Hungarian production, only available from one dealer, not common in Hungary. Brand: Capstone.</p> <p>The smallest unit is 30 kW, the biggest is 1 MW.</p> <p>The basic installation cost 3 -4 thousand euro, but it does not include the installation of the heat recovery system, or the transportation price, which in extreme case can be EUR 30 000.</p>
----------	---

Other data has not been collected. Older data sources exists with data for e.g. Denmark, but has not been included in the datasheet.¹⁰²

Regarding the projections, IEA indicates decrease of installed costs (-20 to -30 % by 2030 and -30 to -50 % by 2050), improvement of total efficiency (70-75 % by 2030 and 75-85 % by 2050) and development of delivered energy costs (-10 to +5 % by 2030 and -15 to +20 % by 2050) – hence a possible minor improvement, but large uncertainty.

¹⁰² Hanssen, Riikonen et al., *Operating Experiences from 18 Microturbine Applications for CHP and Industrial Purposes*, http://www.dgc.eu/sites/default/files/filarkiv/documents/C0404_microturbine_applications.pdf, 2004.

2.14.11 Datasheet

Please refer to the detailed datasheets in the spreadsheet at <http://data.europa.eu/89h/jrc-etri-techno-economics-smaller-heating-cooling-technologies-2017>

2.15 CHP engines – internal combustion engine, natural gas & diesel

2.15.1 Technical description

The products of micro and mini CHP available on the market are mostly based on conventional gas engines (this section) and to a minor extend Stirling engines fuelled by gas.

A conventional gas engine is a piston engine where the combustion takes place inside the cylinder. The gas engine is driven by a mix of gas and air, which is compressed and then ignited. When ignited, the mix of gas and air expands and the expansion moves the piston, which through an intermediary device runs a generator, producing electricity. The movement of the piston also result in the compression of the next portion of gas and air. The engine and the exhaust gas are cooled by water and the heated water can be used for heating purposes. Thereby, the gas engine produces both heat and electricity. In large-scale applications, useful heat is generated from cooling water, oil cooling and flue gas cooling, increasing the efficiency of the whole system. This is, however, not the case for small-scale applications such as those included in this catalogue.

Gas engines used for micro and mini CHP applications are spark ignition engines using spark plugs to ignite the mix of gas and air. Spark ignition engines are commonly categorized according to the fuel/air ratio:

- In "lean burn engines" the engine runs with a low fuel/air ratio. The combustion temperature and hence the NO_x-emission is thereby reduced. Lean burn engines are normally equipped with oxidation catalysts.
- In "stoichiometric combustion engines" the amount of air equals exactly the amount of air necessary for (theoretically) complete combustion. Stoichiometric gas engines need lambda (/Oxygene) sensors and three-way catalysts to reduce emissions.

Micro and mini CHP engines are typically four-stroke water-cooled engines. Some of the smallest units are with only one cylinder. An example of this is for instance a 1 kW_e micro-CHP unit from Honda. These micro/mini CHP gas engines have normally not a turbo charger (increasing an engine's efficiency by forcing extra air in to the combustion chamber), contrary to larger engines (>300 kW_e).

The gas engine technology has been used for many years. During the years, the efficiency has been steadily improved and the emissions have been reduced. The mechanical (or electrical) efficiency of a gas engine is around 20 % as annual average for micro-CHP units and 28-36 % for mini CHP units. The combined efficiency (electricity and heat) is on the level of 80-90 %.

Micro and mini CHP gas engine units are typically delivered in a noise insulated cabinet.

Gas engines can start up fast. They are able to operate at part load, however with some decrease in efficiency.

Diesel engines has higher compression of the fuel. Diesel engines has higher NO_x-emissions than gas engines, which is reflected in the Ecodesign requirements.

2.15.2 Current use and possible evolution (including best available technology and research)

Combined heat and power units with a diesel engine and a flue gas cooler are on the market, but are not addressed in this section (cf. section 2.15.1). That type of system needs to be cheaper and possibly also solve some problems with soot and NO_x.

Research and development

The research and development activities are focused on improving the catalyst systems, improving the mechanical (or electrical) efficiency and to develop professional systems for installation and service.

Examples of best available technology

The product that is currently the most popular in terms of numbers sold and installed worldwide is based on a Honda gas engine with a power output of approximately 1 kW and a heat output of approximately 3 kW. More than 100,000 of this type of micro-CHP unit have been installed in Japan. Hence, this represents the best price/quality product. A number of suppliers promote and sell mini CHP units for natural gas, LPG and/or biogas.

German producer Senertec produces the Dachs, primarily for multifamily dwellings, with an electric effect of 5 kW and a thermal effect of 12 kW.

2.15.3 Conditions/restrictions related to the use of the technology

The EU Ecodesign regulation EU 813/2013 sets requirements for new cogeneration units as explained in Section 2.14.3. The regulation also sets limits to NO_x emissions for new equipment from 26. September 2018.

Technical restrictions regarding the connected central heating system

The upper limit for the return temperature is 70°C (60°C when combined with a flue gas condenser), which therefore also is the technical restriction for connected central heating systems.

2.15.4 -Input and output (energy carriers)

Input

The input is natural gas or diesel. Some CHP units may be delivered for LPG or biogas operation as well.

Output

The output is electricity as well as heat for space heating and for hot tap water production. The electricity produced can be consumed in the building or in case the electricity production exceeds the demand it can be exported to the electrical grid.

2.15.5 Typical capacities

Typical heat capacities for micro and mini CHP gas engines are from 3-300 kW. Typical electrical capacities are from 1-180 kW.

Gas engines are also manufactured in much larger sizes, i.e. up to around 8 MW_e.

2.15.6 Advantages and disadvantages

The main advantage of a gas engine is to a large extent common with generic advantages of CHP. It is proven and commercially available technology producing both electricity and heat. As for other micro and mini CHP technologies, a gas engine makes it possible to replace heat boilers with combined heat and power (CHP) which increases the overall energy efficiency. Furthermore, if operated in an optimal way,

there is a possibility that gas engines as a distributed electricity generator can lead to decreased network losses and costs in the electrical grid.

Disadvantages are some level of noise, a relative high level of emissions and relative high maintenance and service costs.

2.15.7 Environmental considerations

Gas engines have relative high emissions (cf. the data sheet below). When used for micro-CHP applications, however, the emissions can be reduced by use of efficient catalyst systems. This is however, not specific to CHP applications.

2.15.8 Applications with combinations of other technologies

The technology is appropriate for meeting electricity as well as heating demand. Supplementary heat production capacity and/or heat storage would be relevant. Supplementary heat production could be a boiler.

2.15.9 Indications of notable differences of techno-economic performance or applicability across Europe

Table 2-17: Techno-economic data for CHP with internal combustion engine, natural gas. Comments on these data are provided in the table below.

	2.15 CHP-eng-gas	DK	PT	H	D
Small	Nominal electric capacity for one unit (kW)	3.2	2.5	-	12
	CAPEX (€/kW)	4 688	6 400		1 721
	CAPEX (€/unit)	15 000	16 000		20 650
	- hereof equipment (%)	70%			95%
	- hereof installation (%)	30%			5%
	Additional specific investment (€/unit)	4 500			2 550
	Fixed O&M (€/unit/year)				310
Variable O&M (€/GJ)	1.2				
Large	Nominal heating/cooling capacity for one unit (kW)	300	1 414	68	-
	CAPEX (€/kW)	400	726	1 200	
	CAPEX (€/unit)	120 000	1 027 000	81 600	
	- hereof equipment (%)	80%			
	- hereof installation (%)	20%			
	Additional specific investment (€/unit)	200			
	Fixed O&M (€/unit/year)				
Variable O&M (€/GJ)	1				

DK	An auxiliary burner, boiler or electrical heating must supply remaining heat. Higher O&M costs are also seen.
PT	According to CODE project, cogeneration is in its infancy in southern western Europe ¹⁰³ and most of the existent plants are in the industrial sector. The case here presented is Vaillant ecoPOWER 1.0 model available in northern Europe based in natural gas.

¹⁰³ Italcogen, CODE: Work Package 3 – Comparison of Member State Approaches Region Overview, South West Region, WP-report in the CODE-project, <http://www.code-project.eu/wp-content/uploads/2010/12/Region-overview-South-West.pdf>, 2011

H	There is no Hungarian production, only available from dealers. Brands: MAN, Stratos. Installation costs, O&M costs and additional investment costs are not available, since they vary a lot depending on the local conditions.
D	Price includes 750l accumulation tank. Installation costs assumed to be double (10-12 man-hours) of the costs for a gas boiler, due to electrical installations. micro-CHP is very popular in Germany and marketed aggressively by the suppliers.

Increased efficiency, reduced emissions and reduced CAPEX is expected. This is based on the Danish data.

For diesel, only data for Germany is available:

Diesel:

Table 2-18: Techno-economic data for CHP with internal combustion engine, diesel. Comments on these data are provided in the table below.

	2.15 CHP-eng-diesel	DK	PT	H	D
Small	Nominal heating/cooling capacity for one unit (kW)	-	-	-	10
	CAPEX (€/kW)				2 145
	CAPEX (€/unit)				21 450
	- hereof equipment (%)				98%
	- hereof installation (%)				2%
	Additional specific investment (€/unit)				2 550
	Fixed O&M (€/unit/year)				
	Variable O&M (€/GJ)				

DK	
PT	
H	There is no CHP diesel engine market in Hungary
D	Includes all installations at connection to the power grid (most small-scale CHPs come with either an AC-generator or DC/AC-inverter. No expenses for exhaust gas system included. Additional specific investment 750 l Buffer tank & new electric board and net meter for sold/supplied electricity.

2.15.10 Datasheet

Please refer to the detailed datasheets in the spreadsheet at <http://data.europa.eu/89h/jrc-etri-techno-economics-smaller-heating-cooling-technologies-2017>

There is no CHP diesel engine market in Hungary.

2.16 CHP engines – Stirling engine

2.16.1 Technical description

The products of micro and mini CHP available on the market are mostly based on conventional gas engines and to a minor extent Stirling engines fuelled by gas.

A Stirling engine is a piston engine, but opposite to traditional piston engines, the combustion takes place outside the cylinder. The engine is driven by temperature differences created by external heating and cooling sources. One part of the engine is permanently hot, while another part of the engine is permanently cold.

Inside the engine, there is a working gas, which for instance can be pressurised air or helium. The working gas is moved between the hot and the cold side of the engine by a mechanical system comprising a displacement piston coupled to a working piston. When the working gas is heated in the hot side of the engine, it expands and pushes the working piston. When the working piston moves, the displacement piston forces the working gas to the cold side of the engine, where it cools and contracts. The detailed mechanical solution and layout of the Stirling engine can be different from one type of engine to another.

During operation, the movement of the piston runs a generator, which produces electricity. When the working gas cools and contracts at the cold side of the engine, it gives off heat, which can be used for heating purposes. Thereby, the Stirling engine produces both heat and electricity.

Because the Stirling engine simply just converts hot air to mechanical energy, the Stirling engine is also called a hot air engine.

The Stirling engine is based on an old principle invented already in 1816. However, the engine has not yet really had its major commercial breakthrough.

The mechanical (or electrical) efficiency of a Stirling engine is for the best commercial available Stirling engine based units of approximately 25 %. However, for most small Stirling engines, the mechanical efficiency is lower, e.g. in the range of only 12 % as annual average efficiency.

The engine principle is very flexible with respect to fuels, which make the engine interesting also in relation to the use of renewable energy sources. The Danish company Reka A/S manufacture a Stirling engine fuelled by biomass. However, this engine is too large for one-family houses and many apartment complexes. For these applications, at least today and for the next couple of years, gas fuelled mass produced Stirling engines are considered the most applicable/realistic options.

This technology description concerns Stirling engines fuelled by natural gas down to a size of approximately 1 kW electricity and 7-15 kW heat. A technology description of a Stirling engine fuelled by biomass and with a heat capacity of 120 kW can be found in the catalogue "Technology Data for Energy Plants" published by the Danish Energy Agency and Energinet.dk.

2.16.2 Current use and possible evolution (including best available technology and research)

Research and development

Research and development activities take place in many countries including Denmark. One of the challenges is to increase durability of the heat exchangers and to ensure tightening of the engine since it operates at high pressure. Another challenge is to increase the mechanical (or electrical) efficiency.

Examples of best available technology

Major suppliers like Viessmann, Vaillant and German micro-CHP-specialist SenerTec offer very similar products, which are thus assessed to be state-of-the-art BAT.

2.16.3 Conditions/restrictions related to the use of the technology (indication of required investments for application in all types of buildings)

The EU Ecodesign regulation EU 813/2013 sets requirements for new cogeneration units as explained in Section 2.14.3. The regulation also sets limits to NO_x emissions for new equipment from 26. September 2018.

Technical restrictions regarding the connected central heating system

Stirling engines for the domestic application are typically combined with a condensing natural gas boiler for peak loads, backup and temperature boosts. Therefore, Stirling engines are a suitable alternative to e.g. conventional natural gas boilers.

2.16.4 Input and output (energy carriers)

Input

The input is natural gas. Some CHP units may be delivered for LPG or biogas operation as well. Many other types of fuels are possible to apply, since there is no combustion inside the engine, but this is not widely applied.

Larger Stirling engines can also be fuelled with biomass or waste (not covered by this technology description).

Output

The output is electricity as well as heat for space heating and hot tap water production. The produced electricity can be consumed by the building or in case the electricity production exceeds the demand it can be exported to the electrical grid.

2.16.5 Typical capacities

Typical heat capacities are from 7-15 kW. Typical electrical capacities are from 1-7 kW.

2.16.6 Regulation ability (electricity)

The heat load can be changed, but the part load options are limited (cf. the data sheet). The electrical output, however, cannot be changed as quickly as in traditional engines.

2.16.7 Advantages and disadvantages

The main advantage of the Stirling engine principle is that it is flexible with respect to fuels. Regarding Stirling engines fuelled by natural gas, the advantage of Stirling engines are low emissions, few vibrations, low service requirements and long lifetime.

Compared to internal combustion engines, Stirling engines can more easily use renewable heat, has a lower noise level and lower maintenance costs.

A disadvantage is higher investment costs, compared to internal combustion engines, and they are larger and heavier. A Stirling engine needs to warm up for a longer time than internal combustion engines, and limited possibilities of operating at part load. There are still some challenges to be solved regarding durability of the heat exchangers in the Stirling engine as well as tightening of the engine because the Stirling engine operates under a high pressure (approximately 80 bars). Furthermore,

the Stirling engine has a long start up time and it has a relatively high start-up energy consumption.

2.16.8 Environmental considerations

Emissions depend on the external heat source applied. When operating, the Stirling engine has relative low emissions due to the continuous combustion.

2.16.9 Applications with combinations of other technologies

Similar to micro turbine and CHP-engines, the technology is appropriate for meeting an electricity as well as a heating demand. Supplementary heat production capacity and/or heat storage would be relevant. Supplementary heat production could be a boiler.

2.16.10 Indications of notable differences of techno-economic performance or applicability across Europe

Table 2-19: Techno-economic data for CHP sterling engine. Comments on these data are provided in the table below.

	2.16 CHP-eng-stirling	DK	PT	H	D
Small	Nominal heating/cooling capacity for one unit (kW)	12		0.07	
	CAPEX (€/kW)	1 167		4 143	
	CAPEX (€/unit)	14 000		290	
	- hereof equipment (%)	70%			
	- hereof installation (%)	30%			
	Additional specific investment (€/unit)	4 500			
	Fixed O&M (€/unit/year)				
	Variable O&M (€/GJ)	1			
Large	Nominal heating/cooling capacity for one unit (kW)	15			26
	CAPEX (€/kW)	1 333			673
	CAPEX (€/unit)	20 000			17 500
	- hereof equipment (%)	75%			95%
	- hereof installation (%)	25%			5%
	Additional specific investment (€/unit)	200			1 000
	Fixed O&M (€/unit/year)				250
	Variable O&M (€/GJ)	0.8			

DK	<p>An auxiliary burner, boiler or electrical heater may supply remaining heat.</p> <p>Only one commercial product is on the market in for large-scale.</p> <p>The highest heat capacity among the commercial products on the market today is 15 kW. Even though it is possible to install several units, a Stirling engine is mainly found relevant for one-family houses and for new apartment complexes with a relatively low heat demand (where the number of units can be limited).</p>
PT	

H	There is only one Stirling-engine producer in Hungary, and there is no other dealer. In its web-shop ¹⁰⁴ the biggest engine is only 60-70 Watt for 290 EUR. According to the phone call with the producer, now they design a 2-3 kW engine, but it is only in a design-period.
D	Price based on Viessmann appliance, including an 175l accumulation tank and 100l HTW-tank. No expenses for exhaust gas system included. Installation costs assumed to be double of condensing gas boiler, as electric installations may be needed too.

Stirling engine is not mature technology, the TRL-level is low.

There are only few data available for the Stirling engine, and they show relatively large variations. IEA (ETSAP) indicates a CAPEX of 6,300 for a 1 kW unit, with fixed O&M of 10 EUR/unit/year. This unit has an expected lifetime of 15 years and an efficiency of 77%.

The Danish data indicates increased efficiency and lifetime, as well as reduced CAPEX.

2.16.11 Datasheet

Please refer to the detailed datasheets in the spreadsheet at <http://data.europa.eu/89h/jrc-etri-techno-economics-smaller-heating-cooling-technologies-2017>

2.17 CHP fuel cells – natural gas fuel cell

General for micro-CHP fuel cell units

A fuel cell is a unit, which produces electricity and heat through an electrochemical reaction between fuel and Oxygen. The conversion factor from fuel to electricity is high and fuel cell micro-CHP units have the potential to obtain electrical efficiencies higher than for other cogeneration technologies in the same power range and for the same fuel. The fuel cell technology is scalable without loss of efficiency.

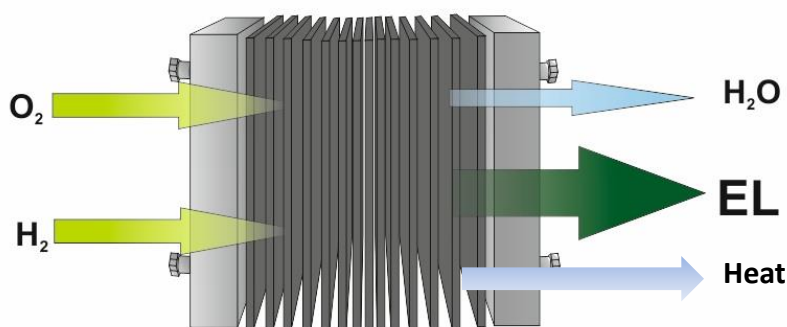

Figure 2-17 Fuel cell principle¹⁰⁵

¹⁰⁴ <http://Stirling-motor-webshop.webnode.hu/motorok-2/>

¹⁰⁵ Energinet.dk; Danish Energy Agency. Technology Data for Individual Heat Production and Energy Transport. Copenhagen: Energinet.dk, 2013.

Fuel cells can be of different types including among others PEM (Proton Exchange Membrane) and SOFC (Solid Oxide Fuel Cell) where the name refers to the electrolyte or membrane used in the fuel cell. Some types of fuel cells operate at a low temperature whereas other types of fuel cells operate at a high temperature.

The fuel cell micro-CHP system should be equipped with a heat storage so that the capacity of the unit can be limited and the fuel cell can optimize its production taking not only the heat demand but also the electricity demand/prices into consideration. This, however, also applies for other CHP technologies, in order to balance the heat production according to the demand.

The fuel cell produces direct current (DC) and therefore, the fuel cell system must be equipped with a DC/AC inverter changing the direct current to alternating current (AC).

Fuel cell based micro-CHP units are today expensive to manufacture but the costs are expected to decrease as the development takes place. The costs are in particular expected to decrease in case the technology becomes more widespread and the units can be manufactured in larger numbers.

2.17.1 Technical description

Natural gas fuel cells use natural gas as fuel and therefore they can simply be connected to the gas grid similar to e.g. natural gas boilers. However, because the fuel cell needs hydrogen as input, a natural gas fuel cell micro-CHP must include a reformer (either separate component or internal reforming) which produces hydrogen from natural gas.

The figure below shows a number of natural gas fuel cells installed as micro-CHPs in individual households. The fuel cells are supplied with natural gas from the natural gas network and they exchange electricity with the electrical grid. The emissions are predominantly limited to CO₂ from the reforming process of natural gas to hydrogen. In addition to this, some water production takes place from the electrochemical reaction between hydrogen and Oxygen.

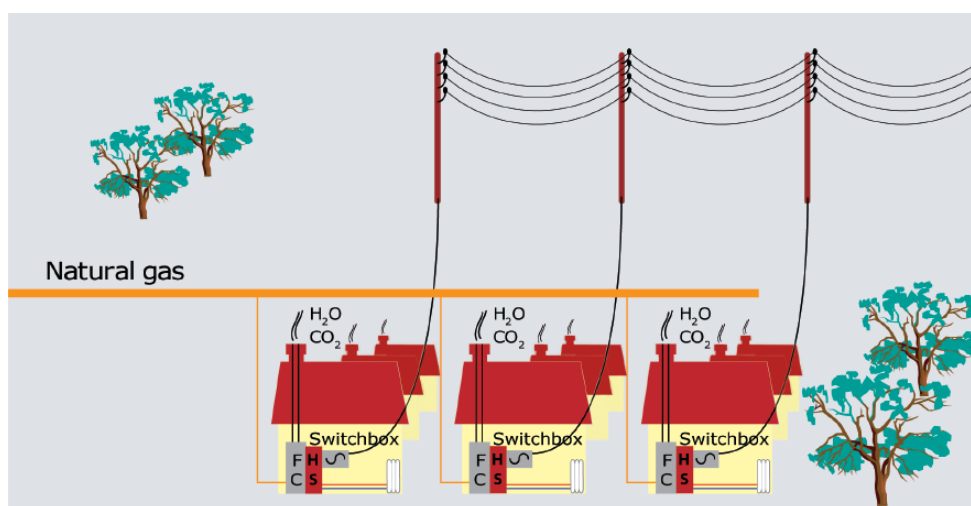

Figure 2-18 Fuel cell micro-CHPs supplied with natural gas from the gas grid and delivering surplus electricity to the electrical grid¹⁰⁶

¹⁰⁶ Energinet.dk; Danish Energy Agency. Technology Data for Individual Heat Production and Energy Transport. Copenhagen: Energinet.dk, 2013.

2.17.2 Current use and possible evolution (including best available technology and research)

Research and development

Natural gas fuel cell micro-CHP units are still under development. The development is in particular concentrated on reducing the costs of the units, increasing the lifetime and increasing the reliability.

In a later phase the research and development activities may be concentrated on how to use the units in a smart grid context so that natural gas fuel cells can optimize their operation according to dynamic electricity prices.

Examples of best available technology

Viessmann Vitocal 300-P is one of the available fuel cells. It is sold as an appliance including the following parts:

- PEM¹⁰⁷-fuel cell with an integrated reformer and an electric capacity of 0.75 kW_{el} and a heating capacity of 1 kW_{th}.
- A condensing natural gas boiler of 19 kW_{th}
- Hot water storage of 170 l and hot tap water tank of 46 l
- DC/AC-inverter

As can be seen, the Vitocal is designed to be connected to the natural gas grid. The reformer can also be bypassed in order to supply the fuel cell with hydrogen directly, when available.

Other solutions include the Senertec Dachs InnoGen, a setup very similar to the Vitocal (including a small fuel cell of 0.7 kW_{el} and 0.96 kW_{th} and a condensing natural gas boiler, buffer tank and inverter), also with a PEM fuel cell.

2.17.3 Conditions/restrictions related to the use of the technology (indication of required investments for application in all types of buildings)

The EU Ecodesign regulation EU 813/2013 sets requirements for new cogeneration units as explained in Section 2.14.3. The regulation also sets limits to NO_x emissions for new equipment from September 26th 2018. The regulation applies to equipment made in more than one copy (serial production).

Technical restrictions regarding the connected central heating system

Depending on the specific fuel cell technology applied (low- or high-temperature), there may be restrictions for suitable central heating systems, regarding an upper limit for the flow and return temperatures. Many market ready appliances focus on low flow temperatures, i.e. floor or wall heating systems and the appliances will be less energy efficient, when supplying heat at higher temperatures.

2.17.4 Input and output (energy carriers)

Input

The input to a natural gas fuel cell micro-CHP unit is natural gas (which is reformed to hydrogen in a reformer before entering the fuel cell).

¹⁰⁷ Polymer Electrolyte Membrane

Output

The output is heat for space heating and for hot tap water as well as electricity. The produced electricity can be consumed by the building or in case the electricity production exceeds the demand it can be exported to the electrical grid.

2.17.5 Typical capacities

Typical capacities for natural gas fuel cell micro-CHP units are 1.5-20 kW heat (including supplementary heater/boiler) and 0.7-1.5 kW electricity.

2.17.6 Regulation ability (electricity)

Natural gas fuel cells can regulate. However, the regulation ability is limited by the dynamic characteristics of the reformer. Furthermore, the fuel cell should preferably be operated at nominal load due to own consumption/efficiency aspects and life time considerations. The regulation ability is expected to be improved in the future.

High temperature PEM-reformers (a frequently used reformer-technology for domestic appliances) have a start-up time of approximately 2-3 hours and a cool-off time of approximately 1-2 hours. It is possible to modulate the load but in general, the modulation is slower than for other CHP-technologies.

2.17.7 Advantages and disadvantages

The main advantage of natural gas fuel cell based micro-CHP units is that they produce both electricity and heat in cogeneration and with a higher electrical efficiency than for other cogeneration technologies in same power range fuelled by natural gas. Thereby, it is possible to convert individual gas boilers outside district heating areas to fuel efficient combined heat and power production (CHP).

Another advantage of natural gas fuel cells is that they produce electricity locally as "distributed generators" which can result in reduced electricity distribution losses and costs.

Depending on the regulation possibilities, natural gas fuel cells can contribute to the balancing of the power system, e.g. by pooling a large number of units into so called virtual power plants (VPP) controlled by e.g. the grid operator.

A limitation for the application of natural gas fuel cell based micro-CHP is that they are dependent of natural gas supply, i.e. a natural gas network.

Furthermore, fuel cells in general are still a niche technology in the heating sector and thus prices are comparably high. Existing appliances only include small fuel cells (approximately covering the electricity consumption in the building) with a major part of the heat consumption being covered by the integrated condensing gas boiler.

2.17.8 Environmental considerations

The emissions from natural gas fuel cells are relatively low.

2.17.9 Applications with combinations of other technologies

The currently available appliances are typically integrated combinations with a fuel cell for baseload and a (condensing) natural gas boiler for peak demands.

2.17.10 Indications of notable differences of techno-economic performance or applicability across Europe

Table 2-20: Techno-economic data for CHP fuel cell gas. Comments on these data are provided in the table below.

	2.17 CHP-fc-gas	DK	PT	H	D
Small	Nominal heating/cooling capacity for one unit (kW)	20	20	-	20
	CAPEX (€/kW)	1 750	1 250		1 240
	CAPEX (€/unit)	35 000	25 000		24 800
	- hereof equipment (%)	80%			98%
	- hereof installation (%)	20%			2%
	Additional specific investment (€/unit)	4 500	465		1 000
	Fixed O&M (€/unit/year)		27		500
	Variable O&M (€/GJ)				

DK	The micro-CHP unit will cover approximately 50-70 % of the total heat demand. The remaining part is supplied from the built in supplementary heater/burner (gas burner or electric heater). The additional investment costs are for the supplementary heater/burner. The investment cost will be lowest if an electric heater is chosen and highest if a gas burner is chosen.
PT	
H	There is no CHP natural gas fuel cells engine market in Hungary
D	The investigated fuel cell has a capacity of 0.75 kW _e and 1 kW _{th} . The fuel cell is installed with a 2-19 kW _{th} modulating condensing natural-gas boiler in one combined unit. Includes a 170 l buffer tank and 46 l hot water storage. The installation is approximately the same as for a condensing gas boiler, i.e. approximately 12 man-hours, including all necessary installations.

Possible explanation for the variation in data for the different countries includes different TRL-levels in the different countries.

Danish installation costs seem very high. It is a cabinet solution (however for Viessmann, it needs to be a specially trained/certified contractor). The Danish projected data indicates extreme reductions of CAPEX. Significant reductions of CAPEX are indicated by IEA Technology Roadmap (40-55 % by 2030 and 60-75 % by 2050).

Additional investments cover e.g. new electric distribution boards and metering (in order to facilitate electricity export) and possibly connection to the natural gas grid.

Increased efficiency is also expected.

2.17.11 Datasheet

Please refer to the detailed datasheets in the spreadsheet at <http://data.europa.eu/89h/jrc-etri-techno-economics-smaller-heating-cooling-technologies-2017>

There is no CHP natural gas fuel cells engine market in Hungary.

2.18 CHP fuel cells – hydrogen fuel cell

For a general introduction to the principle of fuel cells, please refer to Section 2.17, page 115.

2.18.1 Technical description

Hydrogen fuel cells use hydrogen as fuel. One way to produce hydrogen is via an electrolyser, which produces hydrogen from water, using electricity. There are several technologies to do so (e.g. alkaline, PEM, SOEC), alkaline electrolysis being the most well proven electrolysis technology, also on large scale. Steam-methane reforming, the same process as is used in small-scale reformers in natural gas-based fuel cell appliances cf. Section 2.17, is also a well-proven technology for large-scale hydrogen-production. The main difference between the processes is the input (water, methane) and the energy source for the process (electricity, steam).

The production of hydrogen can take place either centrally or locally in each building. If the production takes place centrally, it is necessary to establish a hydrogen distribution network. If the production takes place locally in each building, each building should be equipped with a small electrolyser/reformer and hydrogen storage.

The figure below shows a number of hydrogen fuel cells installed as micro-CHPs in individual households. In the figure, the electrolyser is located centrally, but as mentioned, the electrolyser can also be placed locally in each building. This makes the technology very flexible as it does not require any gas infrastructure.

There are no emissions from hydrogen fuel cells themselves - only some water production from the electrochemical reaction between hydrogen and Oxygen. From a total system perspective, however, the emissions related to the use of hydrogen fuel cell systems depend on how the electricity used in the electrolyser is produced. If the electricity is produced by wind turbines, the net emissions are zero.

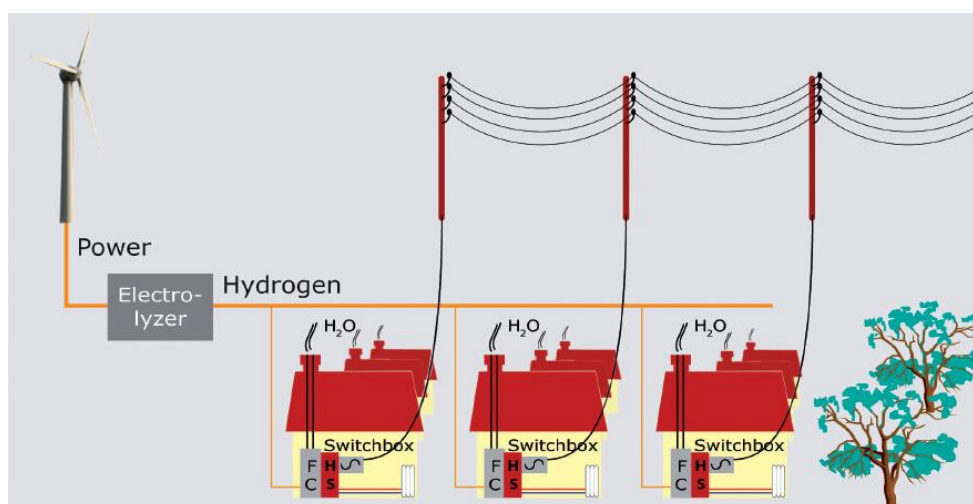

Figure 2-19 Fuel cell micro-CHPs supplied with hydrogen from an electrolyser and delivering surplus electricity to the electrical grid. The electrolyser can be located either centrally (as in the figure) or locally in each building¹⁰⁸

As the hydrogen fuel cell systems use electricity for producing hydrogen, which is stored and used later for production of electricity and heat, the hydrogen fuel cell

¹⁰⁸ Energinet.dk; Danish Energy Agency. Technology Data for Individual Heat Production and Energy Transport. Copenhagen: Energinet.dk, 2013.

systems can serve as indirect electricity storages in the energy system. Thereby, hydrogen fuel cell systems can contribute to incorporating more fluctuating renewable energy sources, e.g. wind power, to the overall energy system.

One big challenge related to hydrogen fuel cell systems is however the energy losses from electricity to hydrogen and back to electricity and heat again. This is illustrated in the figure below by use of an efficiency of the electrolyser of 85 %¹⁰⁹, an electric production efficiency of 45 % and a heat production efficiency of 45 %.

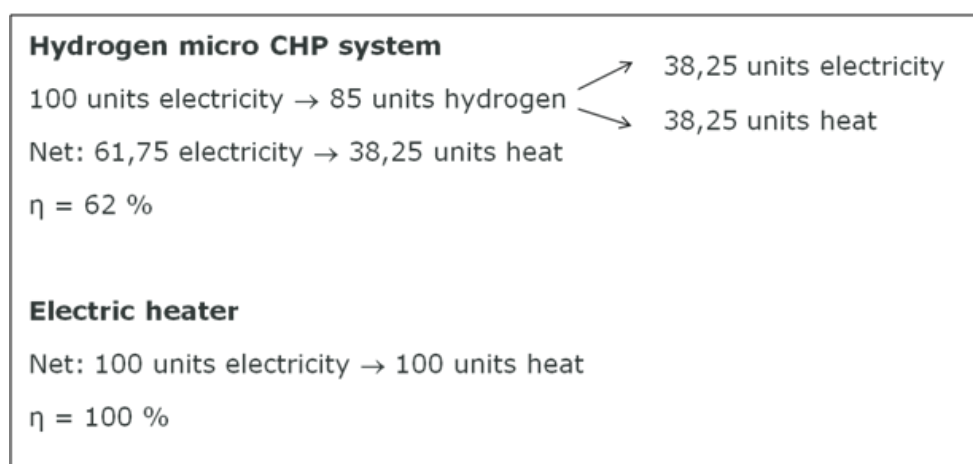

Figure 2-20 Example of net efficiencies, electricity to heat, in the hydrogen micro-CHP solution and electric heaters¹¹⁰

As can be seen from **Figure 2-20**, the net heat efficiency of the hydrogen fuel cell system is 62 % when assuming that the electricity used in the electrolyser has the same value as the electricity produced from the fuel cell unit. This heat efficiency can be compared to the net efficiency of an electric heater of 100 % or an even higher efficiency at heat pumps.

However, the reason why hydrogen fuel cell systems are interesting is that they can serve as indirect electricity storages and opposite to electric heaters and heat pumps fuel cell systems can also produce electricity when needed in the system.

2.18.2 Current use and possible evolution (including best available technology and research)

Research and development

The hydrogen fuel cell micro-CHP units are still under development. The development is in particular concentrated on reducing the costs of the units, increasing the lifetime and increasing the reliability.

In a later phase the research and development activities may be concentrated on how to use the units in a smart grid context so that hydrogen fuel cells can optimize their operation according to dynamic electricity prices.

Storage of hydrogen is a key issue, both in terms of security and costs.

¹⁰⁹ Example for illustration.

¹¹⁰ Example from Energinet.dk; Danish Energy Agency. Technology Data for Individual Heat Production and Energy Transport. Copenhagen: Energinet.dk, 2013.

Examples of best available technology

Most fuel cells in existing European appliances are Japanese products (primarily Panasonic and Toshiba), but e.g. German producer of natural gas based fuel cells with a PEM-converter, Elcore, produce the fuel cell themselves.

2.18.3 Conditions/restrictions related to the use of the technology (indication of required investments for application in all types of buildings)

The same technical restrictions apply as for natural gas fuel cells.

2.18.4 Input and output (energy carriers)

Input

The input to a hydrogen fuel cell micro-CHP unit is hydrogen, typically produced from electricity in an electrolyser or a reformer.

Hydrogen can also be produced via industrial processes. However, for micro-CHP applications with local production of hydrogen this is not relevant.

Output

The output is electricity as well as heat for space heating and for hot tap water production. The electricity produced can be consumed by the building or in case the electricity production exceeds the demand it can be exported to the electric grid.

2.18.5 Typical capacities

Typical capacities for domestic hydrogen fuel cells as micro-CHP units developed are 1-2 kW heat and 1-2 kW electricity. Hydrogen fuel cells are scalable without loss of efficiency. For non-domestic applications, capacities of hundreds of kW and even several MW are available.

2.18.6 Regulation ability (electricity)

Most hydrogen fuel cells have a fast load response. They have a relatively long start up time because they require a minimum temperature for operation. However, the fuel cell should preferably be operated at nominal load due to own consumption/efficiency aspects and lifetime considerations. The regulation ability is expected to improve in the future.

2.18.7 Advantages and disadvantages

The main advantage of hydrogen fuel cells is that they can serve as indirect electricity storages and thereby contribute to incorporating more fluctuating renewable energy sources, e.g. wind turbines, to the system.

Another advantage of hydrogen fuel cells is that they produce electricity locally as "distributed generators" which can result in reduced electricity distribution losses and costs.

Furthermore, hydrogen fuel cells with local electrolysers are not dependent on any gas infrastructure, as they use electricity.

Hydrogen fuel cells can contribute to the balancing of the power system, e.g. by pooling a large number of units into so called virtual power plants (VPP) controlled by e.g. the grid operator.

Hydrogen fuelled fuel cells have a high electrical efficiency compared to other cogeneration units of same power range.

A disadvantage of the hydrogen fuel cell-electrolyser system is the relatively high losses from electricity to hydrogen and back to electricity and heat again.

Other disadvantages comprise hydrogen storage, safety etc. High costs also constitutes a disadvantage.

2.18.8 Environmental considerations

There are no emissions except water from hydrogen fuel cells themselves. From a total system perspective, however, the emissions related to the use of hydrogen fuel cell systems depend on how the electricity used in the electrolyser is produced.

2.18.9 Indications of notable differences of techno-economic performance or applicability across Europe

Table 2-21: Techno-economic data for CHP fuel cell hydrogen. Comments on these data are provided in the table below.

	2.18 CHP-fc-hydrogen	DK	PT	H	D
Small	Nominal heating/cooling capacity for one unit (kW)	1.6	0.9	-	-
	CAPEX (€/kW)	6 563	27 778		
	CAPEX (€/unit)	10 500	25 000		
	- hereof equipment (%)	65%			
	- hereof installation (%)	35%			
	Additional specific investment (€/unit)	4 500			
	Fixed O&M (€/unit/year)		27		
	Variable O&M (€/GJ)				

DK	A built in auxiliary burner will increase the heat output. The micro-CHP unit will cover approximately 50-70 % of the total heat demand. The remaining part should be supplied from a supplementary heater/burner. The additional investment costs are for the supplementary heater/burner. The cost will be lowest if an electric heater is chosen and highest if a gas burner is chosen.
PT	
H	There is no CHP fuel hydrogen cells engine market in Hungary
D	The fuel cells described in Section 2.17 can be fuelled by hydrogen too, by bypassing the reformer. As the availability of natural gas for consumers is higher than hydrogen, no sole hydrogen fuel cell appliances have been identified.

Significant reductions in CAPEX are expected, as well as increase in efficiencies.

2.18.10 Datasheet

Please refer to the detailed datasheets in the spreadsheet at <http://data.europa.eu/89h/jrc-etri-techno-economics-smaller-heating-cooling-technologies-2017>

No hydrogen fuelled fuel cells have been identified in Hungary.

2.19 Heat only other – solar heating

2.19.1 Technical description

Solar energy for hot tap water and space heating is usually based on the principle of pumping a heat transfer liquid from an array of roof mounted solar collectors to one or more storage tanks. Solar heating for dwellings has mainly been developed for coverage of the entire hot water demand during the summer period, and to a minor degree for space heating. Because of the mismatch between demand for space heating and available solar heat, there is need of seasonal energy storage if solar energy should be the only supply. Such storage systems are normally only feasible at very large scale, and therefore solar heating for individual dwellings must be combined with other heating systems, e.g. gas boilers or heat pumps.

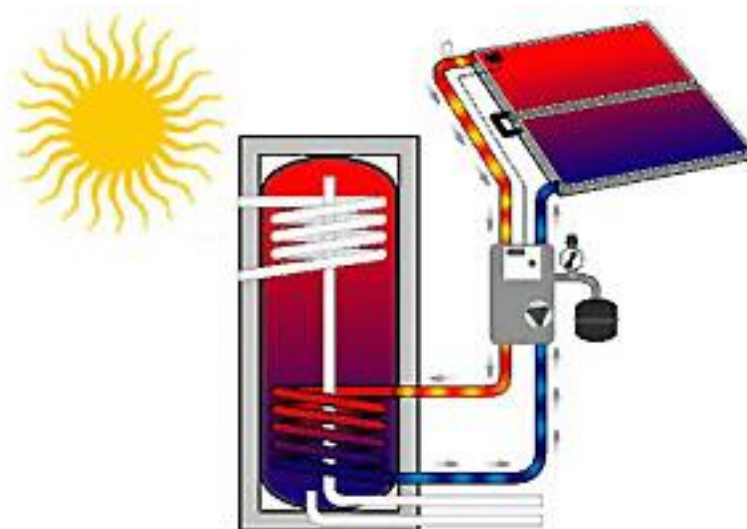

Figure 2-21 Small solar heating system for hot tap water. Auxiliary heat is supplied to the upper heat exchanger coil¹¹¹

Today, solar heating plays a very little role in the Danish and European energy supply, but the potential is enormous. In recent years, the dominating market has shifted from individual systems to large-scale systems for district heating due to economy of scale benefits. However, with the increasing demand for energy efficiency of new buildings, individual solar heating plants are becoming more and more common.

Regulation of Heat Output

The thermal capacity is largely determined by the solar irradiance and the actual operating temperature relative to ambient temperature. As the temperature increases, efficiency decreases. The regulation system in a solar heating plant can switch the available solar energy to be used for hot water or space heating and in some cases to a heat dump in order to avoid boiling or temperature induced damages.

2.19.2 Current use and possible evolution (including best available technology and research)

Research and development

The most relevant R&D needed for further development of solar thermal systems is:

¹¹¹ Energinet.dk; Danish Energy Agency. Technology Data for Individual Heat Production and Energy Transport. Copenhagen: Energinet.dk, 2013.

- advanced and cost effective storage systems for thermal energy;
- more cost-effective solar collectors, either by increased performance or improved low-cost manufacturing processes;
- self-adjusting control systems that are easily adapted to the existing heating system;
- completely new system designs, e.g. air-based wall solar collectors combined with heat pump;
- improved architectural design and smooth integration in buildings;
- production of panels – e.g. extruded absorber aluminium panel;
- absorbers – increased absorptance and reduced emittance;
- improved absorber design – increased heat transfer to fluid and better flow distribution;
- improved plant layout – serial connection of different collector types in rows and optimised serial/parallel connections for solar collector fields;
- control strategies – optimised integration of solar in existing heat productions plant.

The points are mainly from op cit., which contains an extensive list of possible development aspects of solar heating.

The sector is characterized by step-by-step improvements, and the most important improvements in the last 10 years are:

- perfection of stratified storage tanks;
- hot water heat exchanger modules for Legionella prevention;
- large-scale solar collectors for district heating and other applications;
- energy saving pumps for less electricity consumption;
- flexible and pre-insulated installation pipework;
- improved design and integration in roof windows (e.g. Velux).

Examples of best available technology

Most larger suppliers of heating technology do have solar thermal appliances in their program. Please refer to the datasheets for examples.

2.19.3 Conditions/restrictions related to the use of the technology (indication of required investments for application in all types of buildings)

Solar heater for hot tap water with back-up heating has to meet requirements of EU Ecodesign regulation 814/2013 with energy efficiency requirements. The energy efficiency requirements depends on the size of the water heater (tapping capability). There are higher requirements from 26. September 2017. From 26. September 2018 there are also NO_x emission limits for back-up heating.

Technical restrictions regarding the connected central heating system

Most hot tap water systems can be assisted by a solar thermal system. For high solar coverage, it may be necessary to increase the hot tap water storage capacity and integrate with an existing system, which is elaborated in Chapter 3. Solar thermal collectors can be integrated in existing roofs, placed on top or installed on frames, making it possible to install solar thermal collectors in connection to nearly any building.

2.19.4 Input and output (energy carriers)

Input

The primary energy input is solar radiation, of which a part can be converted to thermal energy in the absorber plate. The amount of energy reaching the absorber

depends on geographical site and orientation of the collector as well as possible shadows and ground reflectance. The only non-solar energy input to a solar heating system is the electric energy needed for the pump, controller and optional electric back-up heater (or other supplementing heat sources). This amounts to 5 % of the delivered energy in a typical system.

Output

The output is thermal energy at medium temperature, typically 20-80 °C, depending on operation conditions and collector type. Higher temperatures are possible with special double-glazed solar collectors for district or industrial heating, but they are hardly relevant for DHW and space heating. In combination with heat pumps, it is possible to use very simple and inexpensive solar collectors operating at low temperature. These are typically made of polymers.

The actual performance of a solar heating system is highly dependent on the energy consumption and its distribution on time, i.e. correspondence with the heat demand. This could, however, be handled by applying a heat storage. A high consumption per m² collector is favourable for the efficiency, because it tends to lower the operational temperature. However, this results in a low solar fraction i.e. the part of the heating demand that is covered by the solar heating system, because the output temperature typically does not meet the demand, and therefore has to be increased with another heat production technology.

2.19.5 Typical capacities

Traditionally, the system size is given in m² collector surface. For single-family homes the typical range is from 4 m² in case of a small DHW system to 15 m² for a combined space heating and DHW system. In order to compare with other technologies, IEA has decided that 0.7 kW of nominal thermal power can be used as an equivalent to 1 m² collector surface, but of course this is a somewhat imprecise figure because collectors and operating conditions may be very different.¹¹²

2.19.6 Advantages and disadvantages

Advantage: No pollution. The solar collector can be integrated in the urban environment and may substitute a part of the building envelope. Large energy savings are often possible if the existing heater can be completely switched off during the summer so that standby losses can be substantially reduced.

Disadvantages: Relatively expensive installation, except for large systems. Mismatch between heating demand and solar availability. Requires sufficient area on the roof with appropriate orientation. May compete with photovoltaic systems for the same area.

2.19.7 Environmental considerations

The special selective surface used on most solar collectors is made in a chemical process that in some cases involves chromium. It is important that the process control is adequate to avoid any pollution from this process. The fluid used in most solar heating systems shall be disposed as low-toxic chemical waste.

¹¹² IEA, Technical Note Converting Solar Thermal Collector Area into Installed Capacity (m² to kW_{th}), IEA SHC, 2004.

2.19.8 Applications with combinations of other technologies

The main application of solar thermal is as support for the hot tap water production. Solar thermal can be combined with most existing heat supply technologies. Please refer to Chapter 3 for a comprehensive description.

2.19.9 Indications of notable differences of techno-economic performance or applicability across Europe

Outside the atmosphere of the Earth, the solar radiation is $1\,367\text{ W/m}^2$. The effect reaching the surface of the Earth is approximately $1\,000\text{ W/m}^2$, higher at the equator and lower further to the North or South. The effect is higher perpendicular to the solar radiation, this is why solar collectors should be placed with an angle of approximately 30-40 degrees in Northern and Central Europe.

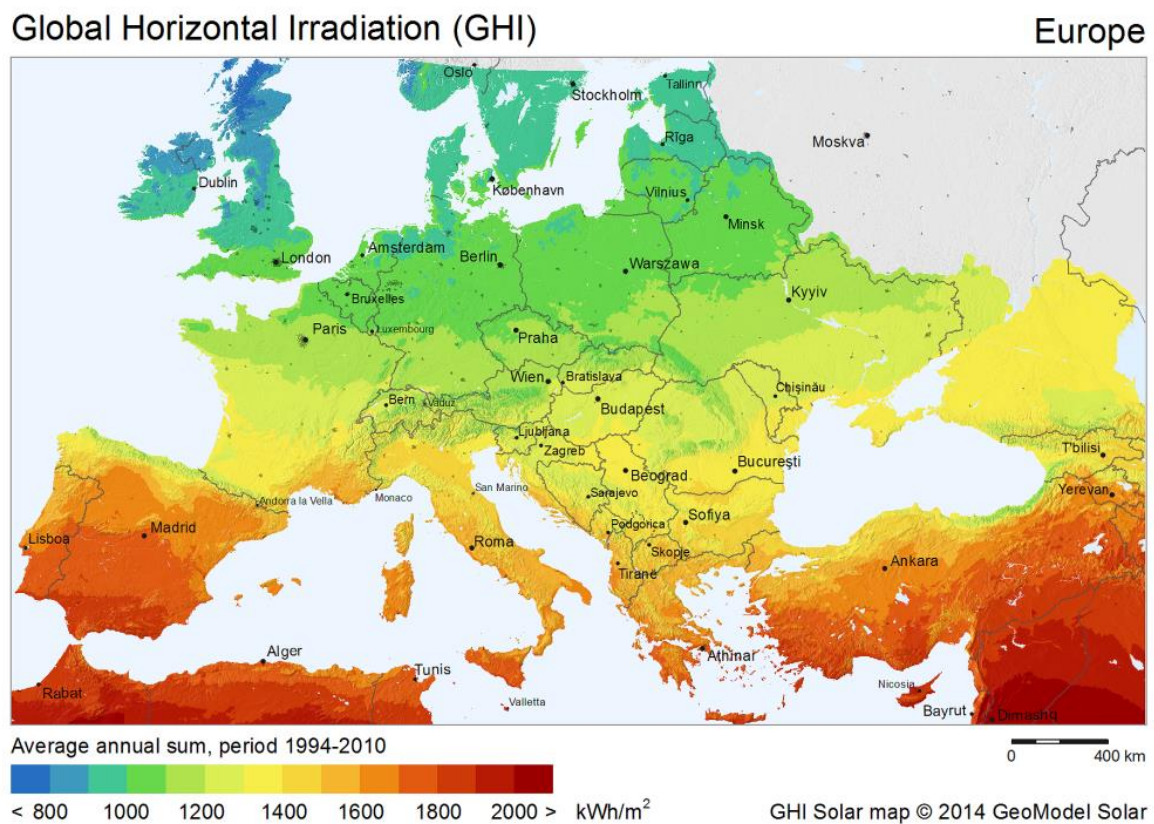

Figure 2-22: Global horizontal Irradiation across Europe.¹¹³

¹¹³ SolarGIS, *Global Horizontal Irradiation Map*, 2014. Downloaded 19 December 2016. <http://solargis.com/assets/graphic/free-map/GHI/Solargis-Europe-GHI-solar-resource-map-en.png>

Table 2-22: Techno-economic data for solar thermal. Comments on these data are provided in the table below.

	2.19 Solar thermal	DK	PT	H	D
Small	Nominal heating/cooling capacity for one unit (kW)	4.2	4.8		7
	CAPEX (€/kW)	1 286	333		700
	CAPEX (€/unit)	5 400	1 600		4 900
	- hereof equipment (%)	70%	98%		85%
	- hereof installation (%)	30%	2%	912 €	15%
	Additional specific investment (€/unit)				
	Fixed O&M (€/unit/year)	40	80		115
Variable O&M (€/GJ)	22				
Large	Nominal heating/cooling capacity for one unit (kW)	200	120		35
	CAPEX (€/kW)	450	333		583
	CAPEX (€/unit)	90 000	39 960		20 400
	- hereof equipment (%)	70%		90%	90%
	- hereof installation (%)	30%		10%	10%
	Additional specific investment (€/unit)				
	Fixed O&M (€/unit/year)	100			115
	Variable O&M (€/unit/year)	500			

DK	<p>Fixed average size but increasing efficiency is assumed. Typical range is from 3-15 m² in one-family houses. 1 m² is equivalent with 0.7 kW.</p> <p>Annual yield 500 kWh/m². Highest figures for new buildings, due to higher efficiency at low temperatures. General improvements and better storage technology assumed.</p>
PT	<p>In average one-family house will have 4 solar thermal panels (2m²/each).</p> <p>O&M costs: Data based on user experience retrieved in online user's forum for discussion. This price is for working fluid recharge and cleaning of the panels.</p> <p>Large-scale: The costs of installation and unit are the same as for domestic installations per unit. Usually large solar plants are simply a huge amount of 2 m² panels.</p>
H	<p>Datasheet for hot water only and hot water and heating.</p> <p>There are two larger Hungarian solar thermal collector producers on the market:</p> <ul style="list-style-type: none"> • CPC solar thermal collector (Spring Solar)¹¹⁴: EUR 234-269/m² • Zöldház Solar¹¹⁵: EUR 163/m² (2.9 m²/panel) <p>Price of the other system-equipment¹¹⁶: 750 l heat storage with one heat exchanger – EUR 945, 50 l buffer tank – EUR 75, Steca control – EUR 126,</p>

¹¹⁴ Spring Solar, *Company Homepage (in Hungarian)*, <http://www.springsolar.hu/hw300-napkollektoros-hasznalati-melegviz-rendszer>, accessed June 2016

¹¹⁵ Zöldház Solar Kft., *Company Homepage (in Hungarian)*, <http://www.zoldhazsolar.hu/arlista.php>, accessed June 2016

	10 l fluid concentratum – EUR 70 , mounting system – EUR 639; tube system and insulation – EUR 557 Large-scale: 80 m ² solar collector, 1500 l heat storage
D	10 m ² flat plate collector (corresponding to 7 kW), installed on top of pitched roof, including 300 l hot water tank. CAPEX for a 5 m ² /3.5 kW system are EUR 3 500.

There are different assessments of the division of costs between equipment and installation. The collected data for Portugal and Germany indicates 90/10, whereas the data for Denmark from the Danish catalogue indicates 70/30. Different assumptions regarding site-specific costs may influence this assessment.

Regarding the projected data, there is a significant development expected regarding district heating applications. This will influence the individual applications as well with regard to increased technical lifetime and reduced CAPEX.

2.19.10 Datasheet

Please refer to the detailed datasheets in the spreadsheet at <http://data.europa.eu/89h/jrc-etri-techno-economics-smaller-heating-cooling-technologies-2017>

The development of prices of SHC-systems is investigated in the SHC Task 54¹¹⁷. The project has not yet concluded on price developments.

2.20 Heat only other – electric heating

2.20.1 Technical description

Electric heating is the general description of technologies that use the heat from electric resistors as a mean of covering a heating demand. The heat from resistors can be transferred to the surrounding air or a water or oil based system. In the context of this report, only the former is considered, whilst electric heaters for water based systems (also called electric boilers) are a different technology. Electric radiators can be wall-fixed installations or movable radiators that only need to be plugged into a power outlet.

In buildings, solely heated by electric heating, electric radiators are mounted in each room. The bathrooms can be equipped with electric floor heating systems. Electric heating can be a supplement or be a complete system.

The hot tap water is made by a hot water tank with an electric heating coil or by an electric instantaneous water heater.

The radiators are equipped with internal thermostats, but systems that are more refined are available, making it possible to programme a temperature schedule individually for each room, according to periods, climatic data etc.

Electric heating can be controlled by external systems, e.g. with timers and room thermostats to achieve an overnight reduction of the room temperature to limit the

¹¹⁶ Zöldparázs Kft., *Company Homepage (in Hungarian)*, <http://www.cseresznye.net/arak/napkollektor-arak.html>, accessed June 2016

¹¹⁷ Fraunhofer-ISE et al., *Publication Homepage for Task 54*, <http://task54.iea-shc.org/publications>, IEA, Solar Heating & Cooling Programme (SHC), 2016

energy consumption when the room is not occupied. In addition, remote internet control is possible.

The installation will normally include a group switch per one or two rooms, making central control very simple to install.

2.20.2 Current use and possible evolution (including best available technology and research)

It shall be taken into account that electrical heating historically often showed unexpected low energy consumptions¹¹⁸. As a curiosity, the statistics show that the average electric heated house has a lower electricity consumption than the average heat pump heated house.

Research and development

Research concerning the future use of direct electrical heating in a smart grid may lead to positive results for this technology, since it could facilitate flexible use of renewable based electricity.

Examples of best available technology

A modern electric heating system is an intelligent system¹¹⁹. Each room can be controlled individually, and the consumption per room can be displayed for the consumer. The bathrooms are heated with floor heating and the rooms with panels. The hot water tank is a 'smart tank' including self-learning controls to maintain the lowest average temperature, while still controlling the risk of Legionella. Storage heaters are used in case of varying electricity tariffs.

2.20.3 Conditions/restrictions related to the use of the technology (indication of required investments for application in all types of buildings)

Electric space heaters are regulated by EU Ecodesign regulation EU 1188/2015 that sets energy efficiency requirements for new equipment after 1. January 2018 of 38 % for heaters above 250 W and 34 % for smaller heaters. The efficiency is based on primary energy and is reduced by accounting for temperature controls.

Technical restrictions regarding the connected central heating system

Electric heating is a technical possibility in nearly any building, as the only technical requirement is a power outlet / distribution board that has the capacity to supply the given effect.

2.20.4 Input and output (energy carriers)

Input

The input is electricity.

Output

The output is space heating and heating of tap water.

¹¹⁸ Dansk Energi (Branch Organisation for Electricity Sector in Denmark), *Statistic of Danish Electricity Utilities (Dansk Elforsyningsstatistik)*, 2008.

¹¹⁹ Lauritz Knudsen, Company Homepage, <http://www.lk.dk/losninger/det-intelligente-hjem-ihc/#>, accessed June 2016.

2.20.5 Typical capacities

Typical capacities for electric heating units are 200-2 000 W per panel. A building that is heated electrically will typically have one or a few panels in each room. The capacity of these panels has to correspond to the heating demand (as a function of room size, insulation and expected outdoor temperatures). Thus, electric heating systems in buildings are in the 5-400 kW range in total.

2.20.6 Regulation ability (electricity)

The control is very flexible and the capacity can be regulated fast from 0 to 100 % and vice versa. As the energy output is hot air or oil, the heat production is nearly instantaneous and dependent on the heat demand, thus limiting the regulation abilities of electric heating in terms of availability for the grid, unless a heat storage is applied.

It should be noted that the heat output is directly correlated to the installed nominal power. In most cases, use of night setback or other forms of periodic heating is very efficient, as the reheating of the rooms can be very rapid, as the reheating can be done very fast, with practically no start-up losses. Furthermore, adding extra capacity is cheap.

Electric radiators can be built as storage heaters with some energy storage. For such radiators, electricity can be turned off for a period but heat is still emitted from the radiator. This ability can be used e.g. to fit time varying electricity tariffs.

2.20.7 Advantages and disadvantages

The advantages are the low installation prices¹²⁰, the very high flexibility, the very efficient reheating after night setback, the very precise room temperature control and easy possibility of remote control.

The disadvantage is the high energy price and the thermodynamic loss of "exergy". If widespread applied, the peak power demand can be critical in some areas, due to limited capacity in the electricity distribution network.

2.20.8 Environmental considerations

The environmental impact due to the use of electricity will depend on the way the electricity is produced.

2.20.9 Applications with combinations of other technologies

Electric heating panels can easily be installed to cover space heat demands in single rooms, combined with a central heating system for the rest of the building. Please refer to Chapter 3, especially Sections 3.6 and 3.7, for examples of combinations.

¹²⁰ Peter Strøm from "EL-Strøm A/S", personal communication.

2.20.10 Indications of notable differences of techno-economic performance or applicability across Europe

Table 2-23: Techno-economic data for electric heating. Comments on these data are provided in the table below.

	2.20 Electrical	DK	PT	H	D
Small	Nominal heating/cooling capacity for one unit (kW)	5	2	1	5
	CAPEX (€/kW)	800	185	120	80
	CAPEX (€/unit)	4 000	370	120	400
	- hereof equipment (%)	70%	100%	100%	98%
	- hereof installation (%)	30%	0%	0%	2%
	Additional specific investment (€/unit)		-		
	Fixed O&M (€/unit/year)	10	0		55
	Variable O&M (€/GJ)			0	
Large	Nominal heating/cooling capacity for one unit (kW)	400		51	
	CAPEX (€/kW)	665		26	
	CAPEX (€/unit)	266 000		1 321	
	- hereof equipment (%)	70%		59%	
	- hereof installation (%)	30%		41%	
	Additional specific investment (€/unit)				
	Fixed O&M (€/kW/year)	10			
	Variable O&M (€/GJ)				

DK	<p>The price includes the complete system including room heaters and hot tap water preparation.</p> <p>O&M costs: Assuming change of heating elements in the hot water tank every 10 years.</p> <p>Danish figures presuppose floor heating in bathrooms. The stated costs are for a complete building, i.e. wall-mounted space heaters in every room and electric floor heating in bathrooms.</p>
PT	<p>Electric space heating is by far the most popular (61.2 %) technology in Portuguese dwellings. This solution is then combined with a stand-alone gas boiler (78.6 %) for hot water preparation.</p>
H	<p>There is no Hungarian producer on the market, main imported brands: Adax, Dimplex, Atlantic.</p> <p>There is no Hungarian producer who makes traditional electric boiler or radiator.</p> <p>The indicated data is from a producer of ion boilers. An ion boiler with a capacity of 7.9-15 kW is EUR 3 210 (heating or hot water)/EUR 3 495 (heating and hot water). However, this technology is quite controversial in Hungary, since its safety is not well-proved, and some products were recalled because of safety reasons. Altogether, this technology is not well-known in the country.¹²¹</p>

¹²¹ <http://www.ewsrendszer.hu/wp-content/uploads/2015/03/ews-prospektus-G4.pdf> and <http://www.ewsrendszer.hu/ews-hoszabalyzo-rendszer/> These links are not working now, so the data might be interpreted as undocumented historical data.

H	There is no Hungarian producer who makes traditional electric boiler or radiator. The largest electric boiler on sale is 51 kW. According to a company who specialized on the electric heating, sometimes they have order for 150-200 kW system, which implemented by cascade installation of larger electric boilers.
D	Appliance for heating of air in a ventilation system. The appliance is installed inside the ventilation pipes and heats the air directly. Assuming that the appliance is installed in combination with other installation at the ventilation system.

No development is expected for the projections.

2.20.11 Datasheet

Please refer to the detailed datasheets in the spreadsheet at <http://data.europa.eu/89h/jrc-etri-techno-economics-smaller-heating-cooling-technologies-2017>

2.21 Heat only other – heat storage

2.21.1 Technical description

In general, there are two kinds of heat storages: Heat storage for space heating purposes and hot water tanks for hot tapped water demands. The main difference between the two is the temperature at which the water is stored, as hot tapped water tanks usually will be stored at higher temperatures.

Most tanks are insulated glazed steel tanks.

2.21.2 Current use and possible evolution (including best available technology and research)

Heat storages have been commonly applied in combination with older boiler installations, without modulation, in order to reach a desirable comfort level and to adjust the heat output to the central heat distribution system from the boiler. Many newer boilers and other heating capacity is typically modulating and thus the need for heat storage is limited. Depending on how well optimized the boiler capacity is in relation to the heat and hot tapped water demand of the building is, a heat storage can be entirely unnecessary.

Research and development

The technology is very well proven. The development is focusing on the optimal integration of the heat distribution and production system in terms of capacity, temperature and controlling.

2.21.3 Conditions/restrictions related to the use of the technology (indication of required investments for application in all types of buildings)

Technical restrictions regarding the connected central heating system

Heat storages are an option in all buildings with a water based central heating system. It requires some space, which depends on the chosen capacity, but most manufacturers offer compact solutions that do not fill more space than regular heating installations/cabinet appliances.

2.21.4 Input and output (energy carriers)

Input

The input is heat from any heat generation device. Water tanks for hot tapped water is typically stored at approximately 60-70°C The temperature of the water that is fed to a thermal storage depends on the central heat distribution system.

Output

Hot water at the desired temperature. If the water is stored at temperatures that are higher than the desired flow temperature, it will typically be shunted with lower temperature water from the return.

2.21.5 Typical capacities

Hot tapped water tanks are built in nearly any capacity in the range 30-500 l. The typical capacities vary highly in the desirable optimum, depending on the heat demand and the temperature levels in the heat distribution system.

2.21.6 Regulation ability (electricity)

Both kinds of heat storages can increase the regulation ability of CHP and electricity consuming technologies by increasing the operation flexibility of these units.

2.21.7 Advantages and disadvantages

Advantages

Reduce peak load capacity requirement of heat production technology.

Disadvantages

Heat loss, space requirement.

2.21.8 Environmental considerations

None.

2.21.9 Applications with combinations of other technologies

Thermal storages must be combined with heat producing technologies in order to cover a heat demand. Please refer to Chapter 3, especially Sections 3.5 and 3.3 for examples of combinations.

2.21.10 Indications of notable differences of techno-economic performance or applicability across Europe

Table 2-24: Techno-economic data for electric heating. Comments on these data are provided in the table below.

	2.21 Storage	DK	PT	H	D
Small	Nominal heating/cooling capacity for one unit (kW)	-	500 l	500 l	2000 l
	CAPEX (€/kW)				
	CAPEX (€/unit)		1 400	793	2 900
	- hereof equipment (%)		95%		85%
	- hereof installation (%)		5%		15%
	Additional specific investment (€/unit)				
	Fixed O&M (€/unit/year)				
	Variable O&M (€/GJ)				

DK					
PT					
H	Installation costs depends on the circumstances.				
	There is one big Hungarian producer on the market. They offer heat storage from 300 l to 1000 l, without coil/with 1 coil/with coil and flexible coil for hot water production.				
	Price of storage (euro)	300 l	500 l	750 l	1000 l
	without coil	309	348	424	481
with one coil	343	555	627	667	
with one coil and one flexible coil	422	793	857	898	
D	Glazed steel, insulated, standing appliance for high temperature application. Costs for installation and basic connections. Costs for integration with existing central heating system not included, but assessed to typically be in the range 2-5 man-hours.				

2.21.11 Datasheet

Please refer to the detailed datasheets in the spreadsheet at <http://data.europa.eu/89h/jrc-etri-techno-economics-smaller-heating-cooling-technologies-2017>

2.21.12 Definitions

Hot water tanks

Tanks for storage of hot tapped water.

Heat storage

Storages for space heating demands. In domestic appliances, these are typically significantly larger than the tank for hot tapped water.

3 Combinations of technologies

Combining two or more heat producing technologies in a bi- or multivalent system can be relevant on single-building level or in local heat distribution systems, supplying a limited number of buildings (cf. the scope of this study). Thus, the technologies applied, are the same as the ones presented in the above chapters. The main difference lies in the application of the technologies, as e.g. higher capacity factors may be achieved, when having multiple, smaller units installed rather than one single appliance.

The combination of technologies is in the present study evaluated on a general level. CAPEX are presented as the expenses for the single units, where a marginal additional cost of combining the chosen technologies (control strategy/PLC and integration of the different units). The technical parameters (e.g. energy efficiency and shares of hot tap water and space heating demands) should be evaluated by modelling a specific heat sink/heat installation setup, as this would be highly depending on a specific setup. This is not carried out in the context of the present study. Thus, technical descriptions of combinations of technologies are limited to the general difference and conceptual considerations regarding the chosen bi-/multivalent heating systems. The present chapter focuses on the differences of the bi-/multivalent systems to the corresponding monovalent heating systems cf. the above chapter. Increased CAPEX for combinations also need to be evaluated according to the increased security of supply, as the "second" heat-producing unit may serve as backup unit too.

Some previously described technologies present exceptions from this, as the currently available appliances are marketed as integrated combinations, combining e.g. an adsorption heat pump and solar thermal, due to the lower limit of the input heat, cf. Section 2.11 or fuel cells in combination with condensing gas boilers, cf. Section 2.17.

3.1 Heat pumps and photovoltaic

Electric heat pumps (EHP) can be installed in combination with a photovoltaic (PV) installation in several ways. By combining the two technologies, (parts of) the electricity that is consumed by the heat pump, can be traced to the source, rather than importing (all) electricity from the grid. Depending on the operation strategy for the heat pump, which can be either 1) only operation when PV-electricity is available or 2) operation according to heat demand, it can be assured that only PV-based electricity is consumed by the heat pump. In this study, it is assumed that a combined EHP&PV-system will be connected to the electricity grid (for reasons of security of supply). A certain share of the electricity consumption of the heat pump may be covered by locally installed PV. The share of this, and thus the share of self-sufficiency is to be determined in the modelling of a specific building, incorporating time series for heat demand, production of the PV, system setup etc.

The way of connecting the PV to the electricity installation of the building/system forms a key role in how the combination of EHP and PV can influence the operation strategy and thus the operation economy. If the EHP and PV are connected to the same meter and net metering¹²² is possible, the EHP will consume PV-electricity when available and thus limit the need for import of electricity from the grid. If net-metering is not an option EHP and PV are not as such combined, but rather to be seen as two separate solutions, installed close to each other.

¹²² Net metering implies that consumers' own production can be deducted from the total amount of electricity consumed, regardless of the time of production. By net metering, any sort of net metering is relevant, typically being hourly, daily or yearly net metering.

One major factor that distinguishes the combination of EHP and PV from installing the two technologies separately is the capacity of the separate appliances. When combining the two technologies, the capacity of the PV may be increased¹²³, in order to achieve higher levels of self-sufficiency (only applicable in net-metering situations). Alternatively, decreasing the capacity of the heat pump to match the achievable capacity of the PV may be applicable, if high levels of self-sufficiency is the main aim for installing this combination.

In conclusion, the combination of EHP and PV can influence the way that the EHP is operated, by forcing it to operate on self-produced electricity only. Due to comparably high CAPEX per installed kW, heat pumps usually have to reach high load factors in order to be an economically feasible solution. There are no considerable additional costs for the combination of PV and heat pumps (presuming the distribution board is prepared for the integration of the two technologies). As described, the main difference lies in the operation economy, as the need for imported electricity may decrease.

Please refer to the detailed datasheet – the datasheet for Hungary provide some information on costs. The cost of a small capacity system (8 kW heat pump and 2 kW PV) is 6,325 EUR, and the cost of a larger capacity system (23 kW heat pump and 8 kW PV) is 17,755 EUR. These prices includes installation.

3.2 Heat pump and boiler (wood pellet, natural gas, oil)

By combining a heat pump with a boiler, two key factors regarding the system design can be achieved:

- 1) The installed capacity of the heat pump can be limited, resulting in lower CAPEX per kW for the total system, compared to a monovalent system with a correspondingly large(r) heat pump
- 2) Increased security of supply: If the heat source for the heat pump (e.g. ambient air or top soil) risks being unavailable in periods, a backup-boiler can ensure security of supply

A typical setup for this type of combination is a heat pump to cover a base load demand, combined with a boiler to cover peak loads and eventually act as a backup-unit, the latter being primarily relevant in larger systems. Alternatively, the two units can be used to cover different demands, as choice of supply temperature has critical impact on the COP of electric heat pumps, cf. Section 1.3.

A key aim for the current application of this combination is to increase the capacity factor of the heat pump as the unit has comparably high CAPEX per kW. I.e. heat pumps will typically have to reach high capacity factors in order to compete with boiler alternatives in a total cost of ownership perspective. Boilers that are to be combined with a heat pump in a bivalent heating system should be able to load shift and regulate quickly, in order to optimize the operation of the heat pump by operating it rather constantly. Modern boiler technologies in the smaller ranges fulfil this criterion.

As for any other bi- or multivalent heating system, this combination necessitates a control setup that supports the input from several heat supply sources. Smaller units are typically available for mono-, bi- or multivalent use. The control units of most heat pumps support a bi- or trivalent operation. In consequence, the operation of the boiler

¹²³ Compared to installing the PV for other purposes than coverage of the electricity consumption of a heat pump.

will typically be controlled by the control unit in the heat pump¹²⁴, but for systems of higher complexity, separate control units may be necessary.

Furthermore, a thermal storage/buffer tank may be necessary, when combining a heat pump with a biomass/wood pellet boiler. The marginal surplus in CAPEX is hence very limited. Furthermore, for all combinations, a shunt valve is necessary, in order to be able to control the desirable supply temperature in the given operation scenarios.

The modulating and fast responding natural gas/oil boilers can typically modulate according to the part load in the hour of operation. The large manufacturers offer integrated solutions with a natural gas/oil-boiler for peak loads and backup, and a heat pump for base load.

Table 3-1 Price-datasheet for air-to-water heat pump & natural gas boiler combination.

Combination-HP(air)-NG-boiler						
	Heat pump only	Boiler only	Combination	Note	Ref	
Small	Data for Germany, 2016					
	Nominal heating capacity (kW)	20	25	20+25	1	
	CAPEX (€/kW)	769	172	440		
	CAPEX (€/unit)	15 389	4 309	19 816	A	1
	- hereof equipment (%)	95%	95%	94%		
	- hereof installation (%)	5%	5%	6%	A	
	Additional specific investment (€/unit)	0	1 700	2 622	B	2
	Fixed O&M (€/unit/year)	300	226	413	C	
Notes						
A. Additional installation time of 3 man-hours.						
B. Gas installation + shunt-valve.						
C. Annual O&M for HP + bi-annual O&M for boiler, due to reduced penetration.						
References						
1. Same as for monovalent systems.						
2. sirAdos www.baupreise.de , WEKA MEDIA GmbH & Co. KG						

¹²⁴ BDH (Branch Organisation of German Heating Sector), *Informationsblatt Nr. 57 "Bivalente Wärmepumpen-Systeme"* (http://www.bdh-koeln.de/fileadmin/user_upload/Publikationen/Infoblaetter/Infoblatt_Nr_57_Bivalente_Waermepumpensysteme.pdf), 2014.

Table 3-2: Price-datasheet for air-to-water heat pump & pellet boiler combination.

Combination-HP(air)-pellet-boiler						
	Heat pump only	Boiler only	Combination	Note	Ref	
Small	Data for Germany, 2016					
	Nominal heating capacity (kW)	20	15	20+15	1	
	CAPEX (€/kW)	769	606	703		
	CAPEX (€/unit)	15 389	9 089	24 596	A	1
	- hereof equipment (%)	95%	97%	95%		
	- hereof installation (%)	5%	3%	5%	A	
	Additional specific investment (€/unit)	0	0	1 122	B	2
	Fixed O&M (€/unit/year)	300	272	436	C	
Notes						
A. Additional installation time of 3 man-hours.						
B. Shunt-valve and (increased) buffer tank capacity.						
C. Annual O&M for HP + bi-annual O&M for boiler, due to reduced penetration.						
References						
1. Same as for monovalent systems.						
2. sirAdos www.baupreise.de , WEKA MEDIA GmbH & Co. KG						

The marginal difference in CAPEX is due to increased control demand of the bivalent system, compared to rather simple monovalent systems. Please note that many manufacturers offer heat pumps and boilers that are prepared for the bivalent application (and even integrated solutions), limiting the marginal increase in CAPEX further. The possible savings in operation depend on the specific system design and chosen operation strategy in practice.

The presented increase in CAPEX for the combination, opposed to two monovalent appliances is based on the pricelist of manufacturer Viessmann. The marginal increase in CAPEX is added to the sum of the two appliances. Installation costs are assessed to be limited to 3 man-hours for increased work with the operation and control.

3.3 Boiler (wood pellet, gas, oil) and solar thermal collectors

Boiler installations can be supplemented with a solar heating system in order to cover heat demands, primarily in the summer months, when solar radiation and outdoor temperatures make the technology available. The availability of solar thermal installations varies by the geographical location of the chosen installation and is in any case concentrated around the summer months. Solar-thermal appliances are primarily used for hot tap water purposes, but can also supply space heating, depending on the heat distribution system and supply temperature levels of the connected heat sink.

In local heat distribution grids, solar thermal appliances can cover the baseload demand in summer periods, when combined with a thermal storage (to balance heat demand and production in the night). For small scale collective heating systems in Denmark, 0.1-0.3 m³ of storage tank are usually planned per m² aperture area of the solar thermal collectors¹²⁵, enabling a solar share of approximately 10-20 % of the total annual heat demand in the grid. The actual solar fraction is to be determined through modelling calculations, as especially the heat demand in summer months determines what solar fraction may be achievable. The remainder will have to be covered by a different heat producing technology, e.g. a boiler or a heat pump. In

¹²⁵ PlanEnergi, *Technology Data Catalogue for Aalborg Municipality for small-scale district heating and individual heating technologies*, 2015.

comparison, tanks with a capacity of approximately 300 l¹²⁶ are a typical size for hot water tanks in single-family dwellings in Germany for solar thermal installations. A Danish guidance regarding the size for domestic installations is approximately 50 l/m² collector area, making it very similar to the German guidance.

In conclusion, solar thermal collectors are a possible supplement to other heat producing technologies. The current application in the small-scale sector concentrates on the production of hot tap water, but coverage of space heating demands is an option too. Installing solar thermal in combination with a boiler system is very simple, as most boilers are prepared to be operated in combination with a solar thermal system and a storage tank.

Table 3-3: Price-datasheet for technology combination of natural gas boiler and solar thermal for hot tap water.

Combination-NG-boiler-solar thermal hot tap water						
	Boiler only	Solar thermal	Combination	Note	Ref	
Small	Data for Germany, 2016					
	Nominal heating capacity (kW)	25	3.5	25+3.5	1	
	CAPEX (€/kW)	172	994	277		
	CAPEX (€/unit)	4 309	3 479	7 906	A	1
	- hereof equipment (%)	95%	81%	87%		
	- hereof installation (%)	5%	19%	13%	A	
	Additional specific investment (€/unit)	1 700	0	3 100	B	2
	Fixed O&M (€/unit/year)	226	115	341		
Notes						
A. Additional installation time of 3 man-hours, for adjustment of control unit/commissioning.						
B. The boiler must have a control unit that facilitates the operation with solar thermal hot tap water production. For Viessmann products, the marginal increase in price is approx. 1,400€/unit in the lower capacity range.						
References						
1. Same as for monovalent systems.						
2. Viessmann Price List						

3.4 Heat pump and solar thermal

Heat pumps can be combined with solar thermal in similar ways as boilers, i.e. with the main purpose of the solar thermal installation being to cover (parts of) the hot tap water demand. An introduction to the combination of solar thermal collectors and heat pumps is given by BINE¹²⁷, a German consumer information portal.

Combinations of solar thermal collectors can be applied in the same way as the combination of boilers and solar thermal, cf. Section 3.3, i.e. with the solar thermal collector covering (parts of) the hot tap water demand, primarily in the summer months. Depending on the system design, the solar thermal collectors may also be used to cover a space heating demand directly.

¹²⁶ German Energy Agency (Agentur für Erneuerbare Energien), *Renews*, Nr. 76, *Erneuerbare Wärme* (ed. *Renewable Heat*), November 2015
https://www.unendlich-viel-energie.de/media/file/419.aee_renews_spezial_erneuerbare_waerme_nov_2015.pdf

¹²⁷ BINE, Information Homepage *Solar-assisted heat pumps*,
<http://www.bine.info/en/publications/themeninfos/publikation/elektrisch-angetriebene-waermepumpen/waermepumpen-plus-solar/>, accessed September 2016

Combined with a heat pump, solar thermal collectors can also serve as a heat source for water-based heat pump technologies, i.e. connecting the solar thermal collectors and heat pump in series (in a similar way, the heat pump may be used to cool the fluid in the solar thermal collectors to increase the efficiency in these). There are several ways to integrate the hydraulic circuit after the heat exchanger of the solar station to the heat pump, e.g. (cf. the illustrations below):

1. Connecting it indirectly, through a hot tap water/buffer tank
2. Connecting it directly to the heat pump
3. Combination of 1) and 2) by making it possible to bypass the hot tap water tank

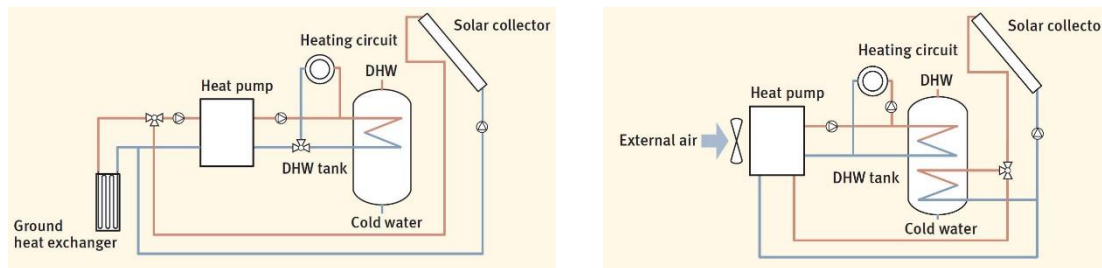

Figure 3-1: Illustrations of the hydraulic connections, previously presented as 2 and 3. ¹²⁸

Furthermore, solar heating can be used to regenerate the heat source in ground heat sources, i.e. using the probes or horizontal collector pipes as a thermal storage. However, partly due to the increased complexity of these systems, this method is only rarely applied. One example of this setup is the SolarVenti-solution¹²⁹, combining simple thermal collectors with the vertical/horizontal heat collectors for the heat pump, in order to regenerate the heat source. In colder regions, there is a seasonal imbalance between the availability of the solar thermal being available as heat source for the heat pump and the size of the heat demand. For this reason, the main application of the combination lies in solar thermal collectors for hot tap water and the heat pump for space heating (and hot tap water when solar thermal is not available).

¹²⁸ Fraunhofer Institute for Solar Energy Systems (ISE), Freiburg im Breisgau.

¹²⁹ SolarVenti, Company Homepage, <http://solarventi.dk/anvendelser-luftsolfanger-solfanger-fritidshus-helaarsbolig-kaelder/energifanger-fra-solarventi-goer-jordvarmeanlaeg-billigere-og-bedre>, accessed November 2016.

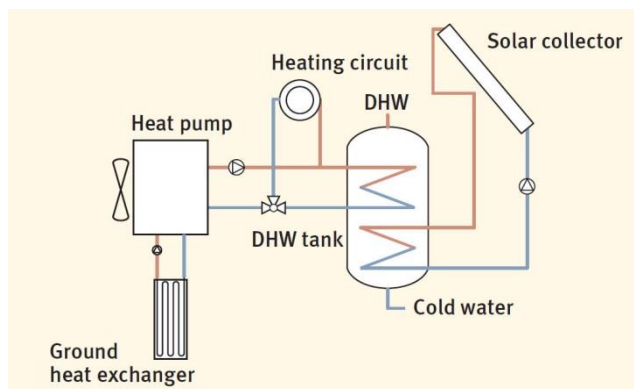

Figure 3-2: Example of hydraulic connection of a heat pump for space heating and hot tap water, assisted by a solar thermal collector for hot tap water¹³⁰

The SHC (Solar Heating and Cooling Program under the International Energy Agency) Task 44 "Solar and Heat Pump Systems" did in the years 2010-13 investigate the possibilities of the described combination. The overall finding of this program was that the seasonal performance factor (SPF)¹³¹ of solar assisted heat pump systems would be higher than those of reference systems without solar thermal support. The highest SPF is achieved, when using the solar thermal collector for tap water heating, while regeneration of a borehole heat source is found only to increase the SPF marginally. Using the solar thermal collector for both hot tap water and regeneration of a borehole is the least efficient combination of solar thermal collectors and heat pumps.¹³² The study finds that the SPF can be raised from 3.73 in the reference (heat pump without solar thermal) to 4.95, when installing the solar thermal for hot tap water in a German model building.

A German study¹³³ also finds the SPF of solar assisted heat pumps system to be higher than that of monovalent heat pumps. However, here it is indicated that the SCOP of the heat pump in isolation may decrease, when connecting it hydraulically to a solar thermal collector. It must be noted that this study evaluates air-to-water heat pumps and thus an additional heat exchanger must be installed, which is assessed to be a major part of the decrease in SCOP. Thus, the loss in SCOP may be (partly) caused by the energy loss due to the additional heat exchanger in the process. The SPF of the total system is in this study found to increase by 0.4 (2.73-3.15) when adding a solar thermal system for hot tap water, while increasing marginally less when using the solar thermal on the cold side of the heat pump as well.

In the project "WP Monitor"¹³⁴, the Fraunhofer ISE comes to similar conclusions, based on measured data. The study evaluated a total of 87 heat pump systems, 14 of which were assisted by a solar thermal system. The study concludes that installing a residential heat pump with an assisting solar thermal collector increases the SPF of the system by approximately 10-20 %.

¹³⁰ Fraunhofer Institute for Solar Energy Systems (ISE), Freiburg im Breisgau.

¹³¹ The SPF is used to describe the efficiency of the total system (relation between the electricity consumption and the useful energy made available)

¹³² Betram, E., Pärtsch, P. & Tepe, R., Impact of solar heat pump system concepts on seasonal performance - Simulation studies, Report in IEA-SHC Task 44, 2006.

¹³³ Ruschenburg, J, Herkel, S, Henning, HM, *Simulations On Solar-Assisted Heat Pump Heating Systems*, Conference-paper for BauSIM 2010, 2010.

¹³⁴ Günther, D, et al., Project-Report for the WP-Monitor-project at FhG-ISE (*„WP Monitor“ Feldmessung von Wärmepumpenanlagen*), FhG-ISE, Freiburg, 2014.

In conclusion, the most efficient way of installing assisting solar thermal collectors with heat pumps is to use the solar thermal systems on the hot side of the heat pump only. Solar thermal systems are most widely applied to assist hot tap water production but can also be used to supply space heating demands – or both. The marginal additional investment, compared to the corresponding monovalent heat pump technology and solar thermal collectors relates to the choice of tank, depending on whether the solar thermal system is to assist the hot tap water supply, space heating or both. There are heat pumps available on the market that are prepared for the bivalent use with solar thermal collectors¹³⁵. These have adjusted control units, integrated regulation abilities to produce hot tap water temperatures according to input from solar thermal collectors and increased buffer tank capacity.¹³⁶

The installation is assessed not to add further expenses, as the integration will be carried out as part of the installation of the two separate technologies. In practice, reductions in installation costs may be achieved, as the same contractor can install and commission both systems (and integrate them).

Table 3-4: Cost-datasheet for combination of heat pump and solar thermal collector for hot tap water production, cf. the technology combination, described in Figure 3-2.

Combination-HP(air)-solar thermal hot tap water					
	Heat pump only	Solar thermal	Combination	Note	Ref
Data for Germany, 2016					
Small					
Nominal heating capacity (kW)	20	3.5	20+3.5		1
CAPEX (€/kW)	769	994	808		
CAPEX (€/unit)	15 389	3 479	18 986	A	1
- hereof equipment (%)	95%	81%	92%		
- hereof installation (%)	5%	19%	8%	A	
Additional specific investment (€/unit)	0	0	800	B	2
Fixed O&M (€/unit/year)	246	115	361		
Notes					
A. Additional installation time of 3 man-hours, for adjustment of control unit/commissioning.					
B. The heat pumps must have a control unit that facilitates the operation with solar thermal hot tap water production.					
References					
1. Same as for monovalent systems.					
2. Viessmann Price List					

For Hungary, a combination of 8 kW heat pump and 5.1 m² solar thermal has the price of EUR 5 715, and a larger system (23 kW heat pump and 15.3 m² solar thermal has a price of EUR 11 810. These prices include installation.

3.5 Heat pump with storage

Thermal storages in the context of heat pumps can be either insulated (steel) tanks or the building mass (i.e. concrete floors) that is heated through floor heating. In retrofit-projects, water tanks are assumed more relevant. In new buildings, both options may be applicable.

¹³⁵ Most manufacturers offer combined solutions, e.g. <http://www.napelem-napkollektorok.hu/akcios-termekeink/csomagarak> with combinations from 8 kW heat pump + 5.1 m² solar thermal collectors for HTW, to 23 kW + 15.3 m² solar thermal collector.

¹³⁶ Viessmann Vitocal 222 (without solar thermal) / 242 (with option for solar thermal) price difference of 7-900EUR/unit for the smaller capacities. For the larger capacities, Viessmann has an integrated control option for connection of a heat exchanger(booster) or one boiler in the regular control unit.

Most small heat pumps are sold with storage, in order to enable the heat pump to operate more constantly at nominal load. In theory, this results in higher SCOP, as the compressors work most efficiently, when operated at nominal load. Many manufacturers therefore market heat pumps as a combined solution, including a storage tank, in order to keep the partial load at an acceptable level. Depending on the specific model, the consumer can choose setpoints for the parameters to base the control strategy on, e.g. room temperature and temperature levels in the storage tank.

By increasing the storage capacity, a heat pump can furthermore be operated to not only meet the heating demand of the heat sink it is connected to, but also according to other external factors, like fluctuating electricity prices or RES¹³⁷, cf. Section 1.3. This can be done to some extent by using the typical storage capacity, as described. By increasing the storage capacity, the possibilities for operating the heat pump according to the electricity price or other (electricity market) signals increases too. For a study¹³⁸, different setups for an air-to-water-heat pump are modelled in a fixed electricity price and smart operation of the heat pump, according to the electricity prices. In the reference scenario, the heat pump is supplied with 500 l of accumulation tank for space heating and 500 l for hot tap water. The capacity of these storages is varied in a scenario analysis, expanding the two tanks to 2 000 and 3 000 l each. The conclusion is that there are marginal gains in SPF of adding the extra 1.500 l, whilst adding additional 1,000 l has no significant impact.

If a smart operation and control strategy is chosen, the heat pump must be controllable by an external part, e.g. through a third part online control system, cf. the considerations in Section 2.6.6. Increasing the storage capacity of a heat pump necessitates a marginal additional investment in the larger tank. A further additional cost may be included for the increased space demand of the larger tank, which is not included in the study at hand. Increasing the storage size is assessed not to result in a significant increase in installation costs, as modern appliances are prepared to operate with a storage system. In the commissioning of a heat pump with an increased storage, parameters regarding the storage size will have to be adjusted, which is assessed to be within the installation budget for the heat pump as a standard appliance, cf. Sections 2.6-2.9.

¹³⁷ Renewable Energy Share (RES)

¹³⁸ Fischer, D, et al., *Investigation of Thermal Storage Operation Strategies with Heat Pumps in German Multi Family Houses*, Energy Procedia, Vol. 58, Pp. 137-144, doi:10.1016/j.egypro.2014.10.420, 2014.

Increasing buffer storage for heat pumps

Small	Data for Germany, 2016	Heat pump buffer storage capacity			Note	Ref
		200	500	800		
	Volume (l)	200	500	800		1
	Energy content at Δt 35°C (kWh)	8.2	20.4	32.7	B	
	Energy content at Δt 10°C (kWh)	2.3	5.8	9.3	B	
	CAPEX (€/l)	3.9	2.1	1.8		
	CAPEX (€/unit)	776	1 034	1 273	A	1
	- hereof equipment (%)	62%	68%	71%		
	- hereof installation (%)	38%	32%	29%	A	
	Additional specific investment (€/unit)	0	0	0		
	Fixed O&M (€/unit/year)	0	0	0		
Notes						
A. The installation costs are assessed to be 7.5-9.5 man-hours, including piping and fitting. The costs do apply for installations of buffer tanks. As described, most appliances are sold as integrated solutions with a (limited) storage volume.						
B. The energy content depends on 1) the difference between the max. Temperature in the storage and the return temperature of the central heating system, determining how far the storage can be cooled down to and 2) the volume of the storage. Heat capacity of water of 4.2 kJ/kg assumed.						
References						
1. sirAdos www.baupreise.de , WEKA MEDIA GmbH & Co. KG						

Figure 3-3: Price-datasheet for a range of buffer tank capacities.

3.6 Heat pump and electric boiler

Heat pumps can be combined with electric boilers in two general ways:

1. One technology for covering hot tap water and space heating demands respectively
2. A heat pump to cover both demands, with an electric boiler for backup- and peak load or to boost hot tap water to temperatures that lie above the efficient range of the heat pump.

Both combinations are common practice. The choice of combination depends on i.e. the desirable supply temperatures of the heat sink and other technical factors. Combining an electric heat pump with an electric boiler in a cabinet-combination can furthermore make a thermal storage unnecessary as (limited) load shifts can be covered by the electric boiler, making it possible for the heat pump to operate similarly as continuous, as if surplus heat production was stored in a storage. However, this affects the system efficiency, as the efficiency of the electric boiler is 1, opposed to the COP of the heat pump in the given operation situation.

The study "WP-Monitor" by the Fraunhofer ISE evaluated the actual use and operation of 87 heat pumps in domestic installations. Approximately half of the air-to-water heat pumps are combined with an electric heater. The reasons for installing electric heaters with air-to-water heat pumps are primarily for health reasons (boosting temperatures periodically to avoid legionella) and security of supply. Regarding the latter, the study finds that there is a correlation in the actual operation of the electric heater and the ambient temperature falling below -5°C. Under the observed climatic conditions (spread across Germany), the electric heaters on average consume 0.9 % of the consumed electricity.

For ground source or groundwater heat pumps, combining electric heaters usually is not as relevant, but may still be installed, especially for temperature boosts and as backup if the heat pump breaks down (considering the very low CAPEX of electric heaters). In the WP-Monitor project, 47 ground source heat pumps were investigated,

seven of which had electric consumption on the electric heater in the investigated period. The observed electricity consumption of electric heaters in the investigated ground source heat pumps is 0.3 % of the total electricity consumption of the heating installation. Therefore, the average SCOP of the investigated heat pumps is only affected marginally, by 0.01.

In conclusion, electric heaters are typically preinstalled in available heat pumps¹³⁹ and the consumption is very limited, presuming the heat pump is dimensioned correctly in order to meet the necessary heating effect of the connected heat sink.

3.7 Electric heating and gas based hot tap water heating

The combinations mentioned above focus on solutions of heating appliances that are connected to central hot water distribution systems for space heating and hot tap water. However, many buildings are not supplied with such systems, as hot water is heated at site, i.e. inside the kitchen or the bathroom. The reasons for not having central heat distribution systems can be many, but the limited need for a piping and control system is assessed to play a key role in many cases. A limited heat demand is assumed another key argument against a central heating system.

There are several ways to cover a heat demand at site of demand, without installing a water-based system. Section 2.20 describes that electric heating panels are one option, oil/bottled gas-fired burners are alternatives to this. The combinations in this category are characterized by a strict separation in energy sources for space heating (if applicable) and hot tap water demands, whereas most technologies in Chapter 2 can cover both, with varying shares.

Thus, the heating technologies mentioned above must be supplemented by hot tap water heating technologies. Most of the technologies, covered in Chapter 2 are applicable for this; however, the thermal capacity of hot tap water units will typically be significantly smaller than those, described in Chapter 2.

The share of buildings with a water-based heating and/or cooling distribution system varies across Europe. Portugal is an example of a country that has a high share of buildings without water-based central heating. Electric space heating is by far the most popular (61.2 %) technology in Portuguese dwellings. This solution is then combined with a stand-alone gas boiler (78.6 %) for hot water preparation.

3.8 Pipe network and connection

3.8.1 Technical description

A district heating (DH) network is used for transportation of heat produced centrally to residential and commercial consumers. The heat can for instance be produced at a central combined heat and power plant (CHP), a central heat boiler, a central heat pump or a central solar heating unit.

The heat is most often used for space heating and hot tap water, but can also be used for industrial purposes or for producing cooling in absorption coolers. The central production of heat allows for a very efficient heat production - for instance by producing heat in cogeneration with electricity at small-scale and large-scale CHP plants.

¹³⁹ Retrofitting an electric boiler, i.e. through a heating spiral in a buffer tank, increases the CAPEX by approximately 170-250 EUR.

A DH system can vary in all sizes from covering a large area as for instance the Greater Copenhagen DH system to a small area or village consisting of only a limited number of houses.

In large DH systems, the DH network may consist of both a transmission network (transporting heat at high temperature/pressure over long distances) and a distribution network (distributing heat locally at a lower temperature/pressure).

In line with phasing out of fossil fuels including also natural gas, there is a possibility that district heating will make up an even larger share of the total heat supply in future. However, this will depend on the competitiveness of district heating compared to individual heat solutions as well as the possibilities of e.g. using the gas infrastructure for renewable energy gases instead of natural gas.

The supply temperature in existing DH systems is typically 60-100 °C, and the return temperature is about 30-60 °C. Typically, the temperatures vary during the year, with lower temperatures in the summer and higher temperature in the winter. The regulation of the network takes place by regulating (increasing or decreasing) the flow of water and/or the temperature.

3.8.2 Current use and possible evolution (including best available technology and research)

Research and development

During the last couple of years, the concept of low-temperature district heating (LTDH) has been developed, tested and demonstrated. In these developing projects, LTDH has been defined as having a supply temperature of 50 °C and a return temperature of 25-30°C at the consumer. In minor networks, these temperatures will require a supply temperature at the heat central of 52-55°C.

However, LTDH concept is not only about the district heating temperatures. It is also crucial that the whole system has an optimised design, where the network heat loss is minimised by using twin-pipe system, having small service pipes and a large insulation thickness. The connected buildings are also part of the system, and the house installations (enabling transfer of heat energy at low temperature levels) and the buildings themselves (the heat demand) should facilitate low temperature operation.

The advantages of LTDH are that the network heat loss is lowered, which gives energy savings and lower fuel costs. Furthermore, the lower network temperatures make it possible to use a larger range of heat sources including more renewable energy sources and surplus heat from industrial processes etc.

If the LTDH is connected to an existing network, a mixing shunt or a heat exchanger station is required to throttle down the district heating temperature.

LTDH may be a bit cheaper to build than conventional DH.

Full-scale demonstration has proven that LTDH is suitable for low-energy houses.

Examples of best available technology

Twin pipes shall be used instead of single pipes, because this ensures lower heat losses and lower construction costs. A twin pipe consists of two service pipes, a supply and a return pipe, in the same casing.

In small dimensions (Ø14-14 - Ø40-40 mm), flexible pipes are preferable, whereas in larger dimensions (Ø27-27 - Ø219-219 mm), steel pipes will be necessary. In very large dimensions (> Ø219-219) like for transmission lines or large distribution lines, twin pipes are not available.

Flexible pipes are made of materials that make it possible easily to install the pipes within some maximum bending angles. The service pipe is typically a plastic (PEX) pipe and can be supplied with an aluminium layer to ensure diffusion tightness. Flexible twin pipes can also have a service pipe consisting of copper, and flexible single pipes are available with service pipes of (cold-rolled) steel.

Both flexible pipes and straight pipes are recommended with diffusion barrier between the insulation and the outer polyethylene (PE) casing in order to keep thermal conductivity low and unchanged over time.

An example of a steel twin pipe and a flexible twin pipe is shown in the figure below.



Figure 3-4 Example of district heating twin pipes. A steel pipe twin pipe (DN50) 60-60/225 mm (left) and a flexible pipe 14-14/110 mm¹⁴⁰

3.8.3 Conditions/restrictions related to the use of the technology (indication of required investments for application in all types of buildings)

3.8.4 Input and output (energy carriers)

Input

Input to the DH network is heat from e.g. a CHP plant or a heat boiler. It can also be surplus heat from an industry etc.

Output

The output from the network is heat (same as the input). The amount of heat that comes out is, however, less than the amount of heat delivered to the network due to network losses. The network loss is in particular dependent on the distance of the network and varies a lot from one system to another. Typical network losses are in the range of 15-20 % (the average loss can be calculated to be 17%¹⁴¹). The loss can be down to app. 7 %¹⁴² in very large systems like in Greater Copenhagen and up to 50 % in systems of very poor conditions.

¹⁴⁰ Energinet.dk; Danish Energy Agency. Technology Data for Individual Heat Production and Energy Transport. Copenhagen: Energinet.dk, 2012.

¹⁴¹ Danish District Heating Association (Dansk Fjernvarme) Benchmarking Statistic 2010/11.

¹⁴² Danish District Heating Association (Dansk Fjernvarme) Benchmarking Statistic 2010/11.

3.8.5 Typical capacities

The capacities of a DH network can be of all sizes depending on the size of the area. For instance, the annual heat demand in the Greater Copenhagen DH system is more than 30 PJ, whereas some small DH areas have an annual heat demand of less than 10 TJ, which is more than a factor 3 000 less.

3.8.6 Regulation ability (electricity)

Not relevant.

3.8.7 Advantages and disadvantages

The main advantage of district heating compared to individual heat solutions is the economics of scale (economy and performance) of the production unit. Furthermore, district heating allows for producing heat in co-generation with electricity (CHP), which contributes even further to both the economy and the performance.

District heating allows for different production units in the same network, which again allows for flexible operation of the units.

District heating makes it possible to utilise waste, deep geothermal heat and surplus heat from industries - energy sources which cannot be used for individual heat solutions.

If district heating is produced at CHP plants or at large heat pumps, and the DH network is connected to heat storages, district heating can give flexibility to the electricity network and help e.g. integrating more wind power. This happens already today and will be of even more importance in future as one among other Smart Grid solutions.

District heating is a flexible system in which the heat production technology can be replaced relatively easily in case of another technology being more economic or environmentally feasible etc.

Finally, district heating is a reliable technology with easy operation for the heat consumers.

The disadvantages of district heating are the relatively high costs of establishing the DH networks and the network losses. There is also a required electricity consumption for pumping water through the pipes.

3.8.8 Environmental considerations

The establishment of DH networks allows for a very efficient heat production with relatively low fuel consumption and relatively low emissions depending on the type of fuel used.

3.8.9 Applications with combinations of other technologies

3.8.10 As a pipe network is an energy transport infrastructure, it must be combined with heat producing technology. Indications of notable differences of techno-economic performance or applicability across Europe

DK	Based on an area with 1 400 (old and relatively large) single-family houses with a total heat demand of 229 TJ/year excluding network losses. Twin-pipe network with a total length of 17 500 m including branch pipes.
----	---

DK	<p>For new building area: Based upon specific data for low-energy buildings. The low heat density refers to an area with 92 single-family houses with heat demand of 2.23 TJ/year. Single pipe network with a total length of 3 200 m including branch pipes. The high heat density refers to a group of terraced houses (41 dwellings) with heat demand of 0.85 TJ/year. Single-pipe network with a total length of 725 m including branch pipes. Values for apartment houses and industrial areas can be very different.</p> <p>For new building area: Includes only heat loss up to the mixing shunt. Heat loss in the further distribution and transmission lines could add a couple of %. Conventional network design results in a relatively high heat loss.</p> <p>Low temperature: Based on 75 single-family houses (from 1997-98) with heat demand of 3.7 TJ/year excluding network heat loss. Twin pipe network with a total length of 2,800 m including branch pipes.</p>
PT	
H	<p>Average price of a DN 100 mm isolated double pipe with pipefitting is ~ 200 EUR/m. The price in case of DN 80 mm is ~ EUR 180/m, and 65 mm ~ EUR 160/m. The prices include the price of the installation as well, but not the price of the rebuild of the road surface</p>
D	

3.8.11 Datasheet

Please refer to the detailed datasheets in the spreadsheet at <http://data.europa.eu/89h/jrc-etri-techno-economics-smaller-heating-cooling-technologies-2017>

3.9 District Heating substations

3.9.1 Technical description

District heating is a hydraulic system of pipes with the purpose of distributing thermal heat to end user of space heating and hot tap water mainly. The thermal heat comes from of a number of sources including heat from combined heat and power production (CHP), surplus heat from industry, and heat from waste incineration and biomass boilers.

The district heating substation is placed at the end user with the purpose of preparing hot tap water and delivering heat for the space heating system based on district heating. Each building with a district heating substation is supplied from a branch pipe connecting the building to the overall distribution network.

The substation is equipped with a hot tap water heater based on either a storage tank or a heat exchanger without storage, e.g. a plate heat exchanger. In some cases, a combination of an external heat exchanger and a storage tank is seen. The space heating is delivered by direct supply of district heating water or by a heat exchanger placed in between the district heating water (primary side) and the space heating water (secondary side). Further, the substation includes all valves, controllers, filters, pumps, etc. that are necessary for the operation.

Figure 3-5 shows a sketch with typical components included in a substation for single-family houses, **Figure 3-6** shows the district heating substation installed in a single-family house.

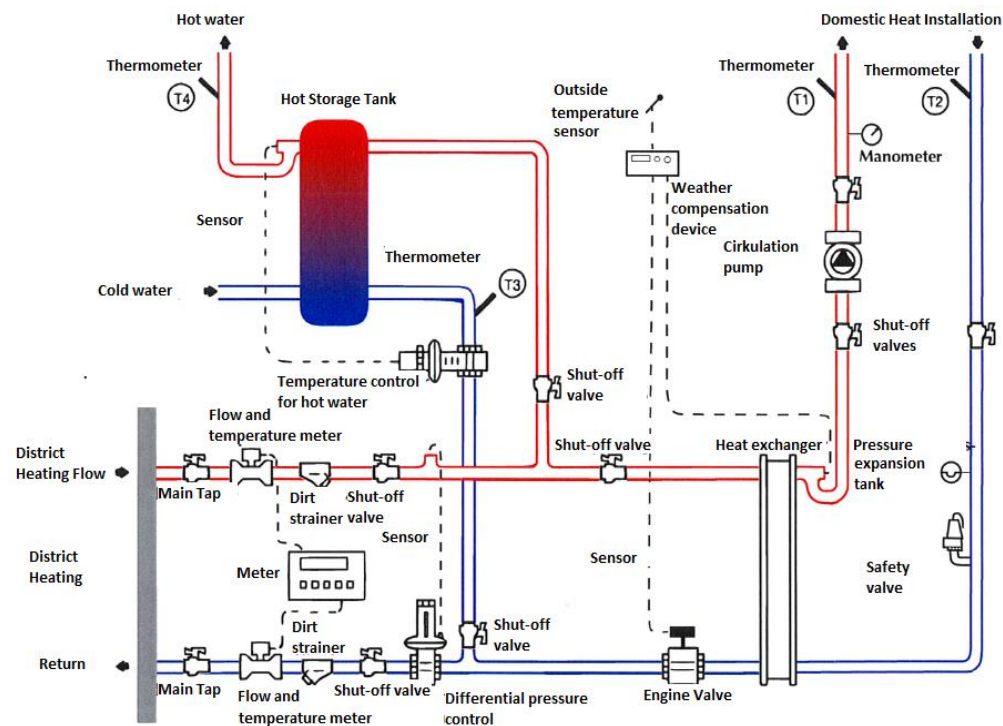

Figure 3-5: District heating substation with hot tap water heater and heat exchanger for space heating in a one-family house. Indirect coupling, in case of no heat exchanger (in the lower right of the diagram), the system is direct coupling. A branch pipe is connecting the building with the district heating network.¹⁴³

¹⁴³ FIF Marketing, Kolding, Denmark.

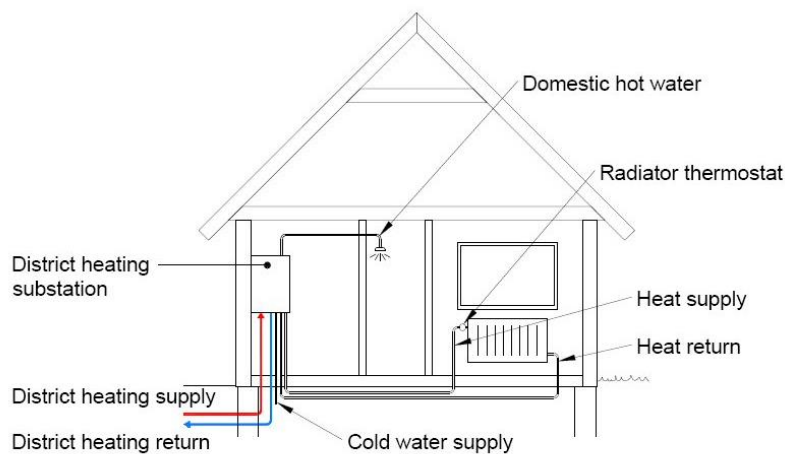

Figure 3-6: District heating substation with hot tap water heater and heat exchanger for space heating.¹⁴⁴

In large buildings, the substation can be placed centrally, or small substations, the so-called flat stations, can be placed in each flat. These different concepts have different implications with regard to comfort – space requirement in the flats and operation and maintenance.

3.9.2 Current use and possible evolution (including best available technology and research)

Research

Research and development are mainly taking place in the following areas:

- plate heat exchanger design;
- control strategies;
- low-temperature operation (< 55°C district heating flow temperature);
- reduction of standby losses (primarily in new single-family houses);
- integration or combination with other technologies (mainly outside Denmark). In Denmark, low temperature district heating combined with electric immersion heating elements or heat pumps for hot water production eventually combined with smart grids are new research areas.

BAT

Some district heating utilities are working on decreasing the district heating supply temperature and have set new requirements for temperature levels for district heating substations¹⁴⁵.

Such low-temperature district heating substations have been demonstrated in the low-energy buildings of Dept. 34 of the housing association "Boligforeningen Ringgården". The substations incorporate efficient plate heat exchanger technology and are able to

¹⁴⁴ Energinet.dk; Danish Energy Agency. Technology Data for Individual Heat Production and Energy Transport. Copenhagen: Energinet.dk, 2013.

¹⁴⁵ Aarhus (2nd largest city in Denmark) District Heating company, Technical Specification for customers, 2011.

supply domestic hot tap water at 47 °C with a district heating supply temperature of 50 °C and return temperatures below 25 °C.¹⁴⁶

In low-energy houses, low standby losses of technical installations are essential to comply with the Danish building code. An example of a very efficient insulation of a substation is seen in Figure 3-7 (note that only the back insulation panel is shown on the photo, the front insulation has been removed).



Figure 3-7: District heating substation with full body insulation for a single-family house¹⁴⁷

Also new electronically controlled heat exchangers have entered the market and are expected to improve efficiency and comfort further¹⁴⁸.

The district heating substations can regulate the heat to comply with any heat demand required within the dimensioned heat demand. On component level, the design criteria include ability to control domestic hot tap water temperature, flow temperature to the heating system, pressure loss and ability to maintain a low return temperature.

Differential pressure regulator: The task of this device is to ensure that the valves in the substation is able to control, but also to restrict flow through the substation and thus achieving a better cooling

Bypass: A bypass immediately after the main taps inside the house installation aims to secure a small but steady flow through the service line whereby this is maintained warm

Booster pump: Maintains a comfortable flow of district heating water through the house installation. A booster pump is not a standard installation, purpose is to maintain the pressure to the farthest consumers in the network (not often applied)

¹⁴⁶ Christiansen et al., Demonstration of lowtemperature district heating solutions for lowenergybuildings (Danish title: Delrapport 2 til EUDP 2008-II, Demonstration af lavenergifjernvarme til lavenergibyggeri i boligforeningen Ringgårdens afd. 34 i Lystrup), Danish Energy Agency, 2011.

¹⁴⁷ Energinet.dk; Danish Energy Agency. Technology Data for Individual Heat Production and Energy Transport. Copenhagen: Energinet.dk, 2012.

¹⁴⁸ Energinet.dk; Danish Energy Agency. Technology Data for Individual Heat Production and Energy Transport. Copenhagen: Energinet.dk, 2012.

Weather compensation: Increases the efficiency of a district heating network, by lowering the supply temperature. There are two types of weather compensation, being at the system level (in the network) and at the consumer level (in domestic installations).

Regarding hot tap water:

Tank: District heating flow is relatively low, hence it requires a smaller service line to the consumer. Max 8 kW. A hot water tank will have a heat loss

Heat exchanger: District heating flow is relatively high since the heat exchanger is placed before the differential pressure controller. Minimum 25 kW. If all consumers in a district heating system have installed a heat exchanger, this will require large power requirements during periods of high hot water consumption. However, the likelihood of all consumers consuming full effect simultaneously decreased with an increase of the number of connected consumers. This simultaneousness (or lack of it) is described as the coincidence factor of a given grid.

3.9.3 Conditions/restrictions related to the use of the technology (indication of required investments for application in all types of buildings)

Please refer to the notes in the datasheet for descriptions of the application of district heating substations at <http://data.europa.eu/89h/jrc-etri-techno-economics-smaller-heating-cooling-technologies-2017>

3.9.4 Input and output (energy carriers)

Input

Heat (district heating).

Output

Heat (space heating and hot tap water).

3.9.5 Typical capacities

The substation space heating capacity is determined based on district heating temperatures and maximum allowable pressure drop.

As an example, in single-family house, the space heating capacity is typically set at 10 kW for district heating temperatures 70°C/40°C and a maximal allowable pressure drop of 0.3 bar.

For large buildings, the capacities typical range from 70 kW to 250 kW for standardised wall-hung products. Above 250 kW, the substations will be individually designed and manufactured. Figure 3-8 shows an example of a substation. The capacities of large buildings refer to district heating temperatures 70°C/40°C (forward/return) in the following.



Figure 3-8: District heating substation for large buildings¹⁴⁹

3.9.6 Regulation ability (electricity)

3.9.7 Advantages and disadvantages

The substation itself cannot be compared with individual heating options like gas boilers or heat pumps. In order to make a comparison, the whole district heating system must be taken into consideration, including distribution network and heat source.

Advantages/disadvantages are here considered in relation to the individual building. Some of the advantages of district heating are:

- compact design - small installation space requirements;
- low maintenance costs;
- very low noise level;
- no pollution produced locally.

Disadvantages are mainly related to the establishment of the district heating network. The laying of the branch pipe requires some extra construction work compared to other heating technologies. Capital costs and distribution network losses of the district heating system may be barriers that prevent district heating companies from providing district heating to customers in areas with low heat density.

3.9.8 Environmental considerations

The environmental characteristics are dependent on the heat input to the specific district heating network. Therefore, no such characteristics are presented. Environmental declarations exist for district heating networks, e.g. the Guidelines for assessing the efficiency of district heating and district cooling systems¹⁵⁰ the declaration for the Greater Copenhagen district heating system.

¹⁴⁹ Energinet.dk; Danish Energy Agency. Technology Data for Individual Heat Production and Energy Transport. Copenhagen: Energinet.dk, 2012.

¹⁵⁰ Euroheat & Power, *Guidelines for Assessing the Efficiency of District Heating and District Cooling Systems*, Ecoheatcool, WP3 report, 2003.

3.9.9 Applications with combinations of other technologies

3.9.10 Indications of notable differences of techno-economic performance or applicability across Europe

Table 3-5: Cost-datasheet for district heating substations.

3.9 District heating substations		DK	PT	H	D
Small	Nominal heating/cooling capacity for one unit (kW)	10			15
	CAPEX (€/kW)	350			252
	CAPEX (€/unit)	3 500			3 780
	- hereof equipment (%)	80%			95%
	- hereof installation (%)	20%			5%
	Additional specific investment (€/unit)	3 000			-
	Fixed O&M (€/unit/year)	150			93
	Variable O&M (€/GJ)				

DK	<p>The generating capacity for one substation is set at the space heating capacity at typical district heating flow/return temperatures of 70/40°C. The size of the water heater capacity is estimated based on the number of apartments that the substation can supply with space heating.</p> <p>The only losses related to the district heating substation are the standby heat losses. For large well-insulated substations, these are considered negligible – 100 % efficiency. However, substations for single-family houses will have a heat loss during summer that cannot be considered useful. Applying best available technology, this is considered to be about 2 %, resulting in 98 % efficiency.</p> <p>The price span covers the variety of designs on the market from very simple direct connected substations with instantaneous water heater to indirect connected substations with storage tank water heater. The price is related to generating capacity.</p> <p>The price is given for an indirect connected substation with storage tank water heater and is related to generating capacity. A large variety of designs are on the market from very simple direct connected substations with instantaneous water heater to indirect connected substations with storage tank water heater. For the simplest solution the price can be 50 % lower than the prices given in the table.</p> <p>Note that the branch pipe should be dimensioned for the use of hot tap water. If there is not any hot water tank, the branch pipe capacity should be higher than the capacity of the DH substation.</p>
PT	
H	<p>Radiator system: EUR 1500-2000 (installation of the whole system, not including the price of the radiators and the boilers, for a typical new house, with 3 rooms, and a living room)¹⁵¹ + radiators: considerable variety in</p>

¹⁵¹ Hamar Homes, Company Homepage, <http://www.otthon-felujitas.hu/>, accessed June 2016.

	<p>price: a typical 500x1100 mm radiator from Hungarian manufacturers are between EUR 29-133¹⁵²</p> <p>Floor heating: EUR 2 500 (for a 130 m² house)¹⁵³</p> <p>Wall heat system: EUR 3 770 (for a 130 m² house)¹⁵⁴</p> <p>Circulation pump: no Hungarian producer, the price of the imported pumps varies in a wide range, the average price of a pump with a max capacity of 60 W is EUR 180</p>
D	Please refer to the datasheet.

No data on projections is included.

3.9.11 Datasheet

Please refer to the detailed datasheets in the spreadsheet at <http://data.europa.eu/89h/jrc-etri-techno-economics-smaller-heating-cooling-technologies-2017>

3.10 Energy savings

The heat demand is estimated by IEA (BLUE Map scenario) to be 5 % higher in 2050 compared to 2007, although the number of households is expected to increase by 67 % and the service sector floor area is almost doubled.¹⁵⁵ Hence, the heat demand per m² is expected to be reduced significantly. The main part of this reduction (63 %) is ascribed to energy-efficient heating and cooling systems and building shell improvements.

The EU-funded project "HeatRoadMap Europe"¹⁵⁶ includes the point of energy savings. The first savings are cheaper than further savings, and this implies, that at some point, the cost of achieving a saving of one unit is more expensive than the cost of supplying the heat. Hence, there is an economic optimum with regard to the feasible amount of heat savings. This optimum depends on the specific costs of heat savings and heat supply and other parameters, but could be in a range of 30-50 % heat savings. Hence, heat savings should be implemented until the price of heat supply is less than the marginal price of additional savings.

Obviously, the optimal point of energy savings depends on the cost of investment, fuel and operation costs. Technologies less exposed for variations in fuel costs, as e.g. renewable energy technologies, imply more certainty in these evaluations.

The costs of energy savings is estimated in different studies. A parameter is the general cost level of civil works for building renovation. Hence, the key results of the evaluated studies are extrapolated based on the statistical indicators.

¹⁵² <http://www.arukereso.hu/futotest-radiator-c3880/f:d-eg-zrt,dunaferr,dunaterm/?st=500+1100&orderby=2>

¹⁵³ <http://gazdasagosenergia.hu/article/149/130-m2-csaladi-haz-ajanlata>

¹⁵⁴ <http://gazdasagosenergia.hu/article/149/130-m2-csaladi-haz-ajanlata>

¹⁵⁵ IEA Directorate of Sustainable Energy Policy and Technology, *Technology Roadmap – Energy-efficient Buildings: Heating and Cooling Equipment*, https://www.iea.org/publications/freepublications/publication/buildings_roadmap.pdf, 2011.

¹⁵⁶ Project Homepage for EU-Project Heat Roadmap Europe, <http://www.heatroadmap.eu>

3.10.1 German data source on cost of energy saving

For Germany, a database summarizing prices from several thousand building and refurbishing projects is used to estimate the costs for a selection of possible energy saving measures (please refer to Section 1.4.5 for a more detailed description of the database).

Prices can either be described based on a refurbishment that is carried out in order to accomplish energy savings or as a marginal project, when refurbishing for other reasons. The latter is chosen as an approach in this report, i.e. prices for energy savings are presented as marginal prices, when working on the given part of the building for other reasons. An example of this is the price for energy savings due to increased/newly installed insulation in the roof. The marginal cost in this example are presented as prices for implementing a certain amount of insulation and includes the materials and labour price for this work. The marginal costs exclude prices for further work on the roof in general, as it is assessed that these refurbishments would be carried out anyways, independent of the energy improvements.

The effects of the energy saving measures are presented in terms of the work that is carried out, e.g. the amount of installed mineral wool or the amount of windows that are changed. Thus, the energy savings are not quantified, as different measures will have different effects, which will depend on the context of the energy refurbishing measures (building, climate, chosen heating installation).

Regarding services to improve the energy performance of a building, apart from the heating/cooling installation, the sirAdos-database presents costs for a variety of measures, of which the following have been assessed to be of high relevance:

- installation of exterior insulation finishing systems (materials and thickness can be varied);
- installation of mineral wool (variety of material thicknesses and place of installation; In pitched roof, between floors, on inner side of walls);
- cavity wall insulation, blown into a cavity wall (cellulose or mineral wool).

In order to estimate a price for energy refurbishment as a total project (i.e. including costs for the entire project of e.g. removing existing parts of the building envelope, gaining access to the roofing (underlay) etc.) prices can be estimated too, when including all relevant services to a detailed project.

A German study¹⁵⁷ evaluates the costs of a large number of refurbishing projects. The costs are given as specific costs (EUR/m²), corresponding to reach a certain specific heating demand. The study presents the energy efficiency improvements, based on the specific heat demand after the renovation. The authors stress the fact that the reference situation affects what specific heat demand is realistic to reach. Therefore, the study does not link the achievable heating demand to the reference situation.

¹⁵⁷ Dieckhöner, C., Hecking, H., *Developments of the German Heat Market of Private Households until 2030: A Simulation Based Analysis*, Springer: Z. Energiewirtschaft, 38: 117-130, 2014.

Table 3-6: Relation between achievable specific demand after refurbishing and costs. Based on Dieckhöner & Hecking, cf. footnote 157.

Cost (€/m ²)	100	200	300	400	500	600	700
Specific heating demand after refurbishment (kWh/m ² a)	140	100	65	50	35	22	18

3.10.2 Danish example of projection of heat demand and building renovation

A Danish study analysed the feasibility of building renovation compared to reduction of heat demand.¹⁵⁸

Heat demand of Danish buildings in 2050:

Area registered. Type; single-family, multi-story, commercial. Period

Energy label; for each type. Labelled share 3-14 %.

Assumptions: Hot tap water: 45 l/person/day heated 45 °C. Commercial: 100 l/m²/year. Indoor temperature: 19-21 °C. Increase of comfort temperature after renovation (19-20 °C)

The study elaborated several scenarios, implying different degrees of renovation (A: low, B: medium and C: high).

Reduction of energy for heating and hot tap water of

- A: 52%, B: 65% and C: 73%

Investments now (part of general renovation in brackets):

- A: 68 (37) million EUR, B: 91 (51) million EUR and C: 103 (57) million EUR.

An important observation in low-energy buildings (new or renovated) is that the expected/calculated reduction in heat demand is not fulfilled. The main reason is changed behaviour of the citizens – they simply prefer higher comfort (higher temperature) instead of reduction of heating costs. This adds complexity to the calculation of the balance of cost of heat savings and cost of heat supply.

Screenings of the energy efficiency potential in buildings with regard to both electricity and heating, shows a potential of 18 % for electricity and 27 % for heating. The largest potential is the ventilation installations in the buildings. The average payback time for realisation of this potential is 3.6 years.¹⁵⁹

¹⁵⁸ Kragh, J & Wittchen, K, Energy Demand in Danish Buildings in 2050 (danske bygningers energibehov I 2050), Danish Building Research Institute, 2010

¹⁵⁹ Draborg, S, *Energy Efficiency Measures in Buildings (Energieffektivisering i bygninger)*, <http://www.teknologisk.dk/ydelser/energieffektivisering-i-bygninger/22690>, Teknologisk Institut, accessed December 2016.

H	<p>ISOMASTER EPS H-80, 8 cm thick polystirol: 6 EUR/m² (in the case of a 120 m² single-family house).</p> <p>Installation cost: 7.1 EUR/m² (in the case of a 120 m² single-family house).</p> <p>The U-value depends on the material of the wall, i.e.¹⁶⁰:</p> <ul style="list-style-type: none"> • small brick wall 25 cm – 0.39 • small brick wall 38 cm – 0.38 • ferroconcrete – 0.39 • panel – 0.37
----------	--

3.10.3 Energy savings costs in Portugal

This section elaborates on the energy saving potential compared to residential building renovation costs in Portugal.

The third largest consumer sector of energy in Portugal in 2013 was the building sector, with a share of 29 % – following transport (37 %) and industry (30 %) sectors.

Between 2000 and 2013, the energy consumption trend of this sector in Portugal has diminished about 5 %, mostly as a result of the energy consumption reduction in the residential building sector. Residential buildings represent the largest share of the building sector (60 %) while non-residential represent 40%. However, this decrease during 13 years period could be divided in two. The energy consumption per dwelling increased around 2%/year until 2009, showing after a continuously decrease of approximately 4 %/year. This decline reflects a mix of energy efficiency improvements driven by policy measures¹⁶¹ and decline in buying power associated to income tax rise and higher energy prices.

In the same period, the residential building sector was one with the largest increase in terms of energy efficiency (36 %- ODEX indicator), including improvements in the efficiency of energy use for heating, water heating, cooking, refrigerator, freezer, washing machine, dishwashers and TV¹⁶².

Recently a study on cost-optimal renovation in residential buildings in Portugal¹⁶³ was made. This analysis tested 43 different renovation packages –including window U-value as well as wall, roof and floor insulation improvements - combined together with eight different combination of building integrated technical systems (BITS). The BITS solutions proposed include different combinations of heat pump, multi-slit, gas boiler or heater and biomass boiler to supply space heating (SH) and cooling (SC) as well as hot tap water(DHW) in single-family and multifamily buildings in 3 different climate zones – due to the difference in terms of energy consumption. The initial non-renewable energy consumption for SH, SC and DHW are shown in the following table.

¹⁶⁰ <http://www.masterplast.hu/files/shop/documents/cid5.pdf>

¹⁶¹ IEA, Policies and Measures Databases, <https://www.iea.org/policiesandmeasures/energyefficiency/?country=Portugal>, accessed December 2016.

¹⁶² Soares, S & Fragoso, R, *Energy Efficiency trends and policies in Portugal*, ADENE, 2015.

¹⁶³ Ferreira, M, Almedia, M, Rodrigues, A, Cost-optimal energy efficiency levels are the first step in achieving cost effective renovation in residential buildings with a nearly-zero energy target, *Energy and Buildings*, Oct. 2016

kWh/m ²	Before 1960		1960-1990		After 1990	
Location	Single	Multi	Single	Multi	Single	Multi
Zone 1	216	37	194	32	66	20
Zone 2	327	48	294	41	103	24
Zone 3	501	134	451	57	170	33

The global costs associated with renovation process results are summed-up on the following table for three degrees of non-renewable primary energy (NRPE) consumption reduction: -50 %, -75 % and -100 % - in the last case, achieving a net Zero Energy Building (nZEB) depend only on renewable energy sources (in these case, biomass). The small variation in renovation costs between buildings built before 1960 and between 1960 and 1990 is due to the effect of large walls - high U-values - until the implementation of the first thermal regulation - RCCTE- which came in 1991.¹⁶⁴ In case of empty cells, no data was available.

Costs 50% NRPE Reduction

EUR/m ²	Before 1960		1960-1990		After 1990	
Location	Single	Multi	Single	Multi	Single	Multi
Zone 1	650	575	680	515	450	435
Zone 2	760	585	780	520	450	450
Zone 3	850	470	880	540	490	460

Costs 75% NRPE Reduction

EUR/m ²	Before 1960		1960-1990		After 1990	
Location	Single	Multi	Single	Multi	Single	Multi
Zone 1	750	595	780	540	520	-
Zone 2	760	605	750	530	520	-
Zone 3	780	590	780	575	550	-

Costs 100% NRPE Reduction

EUR/m ²	Before 1960		1960-1990		After 1990	
Location	Single	Multi	Single	Multi	Single	Multi
Zone 1	700	650	780	610	550	-
Zone 2	760	650	800	580	-	-
Zone 3	780	730	900	635	-	-

¹⁶⁴ Sousa, J ,et al., *Research on the Portuguese building stock and its impacts on energy consumption – an average U-value approach*, Archives of Civil Engineering, LIX, 4, 2013

References

Please note the list at hand represents the references used in the technology description chapters. Additional references have been used in the preparation of the datasheets. These references are listed under each datasheet.

Aarhus (2nd largest city in Denmark) District Heating company, Technical Specification for customers, 2011.

Aisin. GHP E Gas Heat Pump. Brochure: Tecnocaza Climatizzazione.

ASUE (German Sector Organisation for Energy Efficient Gas Technologies), Gas Heat Pumps (German title Gaswärmepumpen), Brochure, 2002, http://asue.de/sites/default/files/asue/themen/gaswaermepumpe_kaelte/2002/broschueren/06_12_02_g_w_pump.pdf

ASUE (German Sector Organisation for Energy Efficient Gas Technologies), Information Homepage regarding market-available gas-heat pump technologies, <http://asue.de/wer-bietet-an#gasmotor-waermepumpen>, accessed November 2016.

BDH (Branch Organisation of German Heating Sector), Informationsblatt Nr. 57 "Bivalente Wärmepumpen-Systeme" (http://www.bdh-koeln.de/fileadmin/user_upload/Publikationen/Infoblaetter/Infoblatt_Nr_57_Bivalente_Waermepumpensysteme.pdf), 2014.

Betram, E., Pärish, P. & Tepe, R., Impact of solar heat pump system concepts on seasonal performance - Simulation studies, Report in IEA-SHC Task 44, 2006.

BINE, Information Homepage Solar-assisted heat pumps, <http://www.bine.info/en/publications/themeninfos/publikation/elektrisch-angetriebene-waermepumpen/waermepumpen-plus-solar/>, accessed September 2016

Buderus, Price Table for Portugal 2016 (Tabela geral de preços 2016) http://www.buderus.pt/files/Buderus_Tabela_geral_de_pre%C3%A7os_2016_PT.pdf, 2016

BWP. Leitfaden Erdwärme. Berlin: Information document by the German Heat Pump Association (BWP), 2014

Christiansen et al., Demonstration of lowtemperature district heating solutions for lowenergybuildings (Danish title: Delrapport 2 til EUDP 2008-II, Demonstration af lavenergifjernvarme til lavenergibyggeri i boligforeningen Ringgårdsens afd. 34 i Lystrup), Danish Energy Agency, 2011.

Danish District Heating Association (Dansk Fjernvarme) Benchmarking Statistic 2010/11.

Dansk Energi (Branch Organisation for Electricity Sector in Denmark), Statistic of Danish Electricity Utilities (Dansk Elforsyningsstatistik), 2008

Danish Environmental Agency (MST), The Handbook of Air(-quality) (Danish original title: Luftvejledningen Begrænsning a luftforurening fra virksomheder), 2001. <http://www2.mst.dk/udgiv/publikationer/2001/87-7944-625-6/pdf/87-7944-625-6.pdf>

DGC, Danish Gasthechnological Institute. Test of more than 100 gas boilers in the DGC-laboratory.

Dieckhöner, C., Hecking, H., *Developments of the German Heat Market of Private Households until 2030: A Simulation Based Analysis*, Springer: Z. Energiewirtschaft, 38: 117-130, 2014.

Draborg, S, *Energy Efficiency Measures in Buildings (Energieeffektivisering i bygninger)*, <http://www.teknologisk.dk/ydelser/energieffektivisering-i-bygninger/22690>, Teknologisk Institut, accessed December 2016.

Ecofys et al. by order of The European Commission, *Towards nearly zero-energy buildings - Definition of common principles under the EPBD*, 2013

Energinet.dk; Danish Energy Agency. Technology Data for Individual Heat Production and Energy Transport. Copenhagen: Energinet.dk, 2013.

EnerTwin, Company Homepage, Technical Description of MicroTurbine. Accessed throughout November 2016.

ERA-Learn 2020, Project Homepage, High-Tech Components for MTT Micro Turbine Based Micro-CHP, <https://www.era-learn.eu/network-information/networks/eurostars/eurostars-programme/high-tech-components-for-mtt-micro-turbine-based-micro-chp>, accessed December 2016.

Euroheat & Power, *Guidelines for Assessing the Efficiency of District Heating and District Cooling Systems*, Ecoheatcool, WP3 report, 2003.

European Commission, Commission Regulation (EU) 206/2012 of 6 March 2012 implementing Directive 2009/125/EC of the European Parliament and of the Council with regard to Ecodesign Requirements for Air Conditioners and Comfort Fans, 2012. <http://eur-lex.europa.eu/LexUriServ/LexUriServ.do?uri=OJ:L:2012:072:0007:0027:en:PDF>

European Commission, Commission Regulation (EU) 2015/1185 of 24 April 2015 implementing Directive 2009/125/EC of the European Parliament and of the Council with regard to Ecodesign Requirements for Solid Fuel Local Space Heaters, 2015. <http://eur-lex.europa.eu/legal-content/EN/TXT/?uri=CELEX%3A32015R118>

European Commission, Commission Regulation (EU) 2015/1189 of 28 April 2015 implementing Directive 2009/125/EC of the European Parliament and of the Council with regard to Ecodesign Requirements for Solid Fuel Boilers, 2015. <http://eur-lex.europa.eu/legal-content/EN/TXT/?uri=CELEX%3A32015R1189>

(Homepage of the) GROUND-MED-project: <http://groundmed.eu/>. Accessed November 2016

EONRG, Potential of the Gas-Heat-Pumps, GHP workshop. Paris, December 2011

EurObserv'er, *Heat Pumps Barometer*, 2016, <http://www.eurobserv-er.org/heat-pumps-barometer-2016/>

European Commission Decision C (2014) 4995 of 22 July 2014 https://ec.europa.eu/research/participants/portal/doc/call/h2020/common/1617621-part_19_general_annexes_v.2.0_en.pdf

European Commission, Joint Research Center, 2014, ETRI 2014 – Energy Technology Reference Indicator projections for 2010-50. https://setis.ec.europa.eu/system/files/ETRI_2014.pdf

European Commission, Joint Research Center, *The JRC-EU-TIMES model- Bioenergy potentials for EU and neighbouring countries*, Annex 7 on labour costs, 2015. https://setis.ec.europa.eu/sites/default/files/reports/biomass_potentials_in_europe.pdf

Eurostat, Dataset "Comparable Price Data Levels" Code tec00120, vers. 2.4.2-r2159-2016-08-11 (accessed November 2016) <http://ec.europa.eu/eurostat/en/web/products-datasets/-/TEC00120>

FAU GeoZentrum Nordbayern et. Al, Homepage of the ThermoMap-project, <http://www.thermomap-project.eu/>, accessed December 2016, August 2013.

Ferreira, M, Almedia, M, Rodrigues, A, Cost-optimal energy efficiency levels are the first step in achieving cost effective renovation in residential buildings with a nearly-zero energy target, *Energy and Buildings*, Oct. 2016

FIF Marketing, Kolding, Denmark.

Fischer, D, et al., Investigation of Thermal Storage Operation Strategies with Heat Pumps in German Multi Family Houses, *Energy Procedia*, Vol. 58, Pp. 137-144, doi:10.1016/j.egypro.2014.10.420, 2014.

Fleiter et. Al, Mapping and Analyses f the Current and Future (2020-30) Heating/Cooling Fuel Deployment (Fossil/Renewable), Final Report for WP2, 2016. <https://ec.europa.eu/energy/sites/ener/files/documents/Report%20WP2.pdf>

Fraunhofer-ISE et al., Publication Homepage for Task 54, <http://task54.iea-shc.org/publications>, IEA, Solar Heating & Cooling Programme (SHC), 2016

Fraunhofer Institute for Solar Energy Systems (ISE), Freiburg im Breisgau.

GasTerra. Gas Heat Pumps. Efficient Heating and Cooling with Natural Gas. Groningen: Castel International Publishers, 2010.

Geowatt, Company Homepage, Heating/Cooling/HMV heat pumps, http://www.geowatt.hu/products_main_en/heating-hmv-heat_pumps_en, accessed June 2016, updated 2013.

German Energy Agency (Agentur für Erneuerbare Energien), *Renews, Nr. 76, Erneuerbare Wärme (ed. Renewable Heat)*, https://www.unendlich-viel-energie.de/media/file/419.aee_renews_spezial_erneuerbare_waerme_nov_2015.pdf, 2015

Günther, D, et al., Project-Report for the WP-Monitor-project at FhG-ISE („WP Monitor“ *Feldmessung von Wärmepumpenanlagen*), FhG-ISE, Freiburg, 2014.

Hamar Homes, Company Homepage, <http://www.otthon-felujitas.hu/>, accessed June 2016.

Hanssen, Riikonen et al., Operating Experiences from 18 Microturbine Applications for CHP and Industrial Purposes, http://www.dgc.eu/sites/default/files/filarkiv/documents/C0404_microturbine_applications.pdf, 2004.

HLNUG (Regional Authority for Environmental Protection and Geology of the Federal State of Hesse), Map of potentials for Hydrogeologicals and Water Management, <http://www.hlnug.de/themen/geologie/erdwaerme-geothermie/oberflaechennahe-geothermie/karten-standortbeurteilung.html>, accessed November 2016, updated September 2016.

Homepage of the SEPEMO-project: <http://sepemo.ehpa.org/>. Accessed November 2016.

IEA, *CO₂ Emissions from Fuel Combustion – Highlights*, <https://www.iea.org/publications/freepublications/publication/CO2EmissionsFromFuelCombustionHighlights2015.pdf>, 2015.

IEA Energy Technology Network, ETSAP – Energy Technology Systems Analysis Programme, Technology Brief, http://iea-etsap.org/E-TechDS/PDF/R02%20Heating%20and%20cooling%20FINAL_GSOK.pdf, June 2012,

IEA Directorate of Sustainable Energy Policy and Technology, *Technology Roadmap – Energy-efficient Buildings: Heating and Cooling Equipment*, https://www.iea.org/publications/freepublications/publication/buildings_roadmap.pdf, 2011.

IEA, Policies and Measures Databases, <https://www.iea.org/policiesandmeasures/energyefficiency/?country=Portugal>, accessed December 2016.

IEA, Technical Note Converting Solar Thermal Collector Area into Installed Capacity (m^2 to kW_{th}), IEA SHC, 2004.

Italcogen, CODE: Work Package 3 – Comparison of Member State Approaches Region Overview, South West Region, WP-report in the CODE-project, <http://www.code-project.eu/wp-content/uploads/2010/12/Region-overview-South-West.pdf>, 2011

Kragh, J & Wittchen, K, *Energy Demand in Danish Buildings in 2050 (danske bygningers energibehov i 2050)*, Danish Building Research Institute, 2010

Lauritz Knudsen, Company Homepage, <http://www.lk.dk/losninger/det-intelligente-hjem-ihc/#>, accessed June 2016.

Nielsen, Elsa, Dybdahl, Marianne og Larsen, Poul Bo. Health effects assessment of exposure to particles from wood smoke. Copenhagen: Danish Ministry of Environment, 2008.

PlanEnergi, *Technology Data Catalogue for Aalborg Municipality for small-scale district heating and individual heating technologies*, 2015.

Robur, Company Homepage, K18 Condensing Absorption Heat Pump Powered by Gas and Air Source Renewable Energy http://www.robur.com/heat_pumps/gas_absorption_heat_pump_for_homes_k18, accessed June 2016.

Ruschenburg, J, Herkel, S, Henning, HM, Simulations On Solar-Assisted Heat Pump Heating Systems, Conference-paper for BauSIM 2010, 2010.

Schwank GmbH & Yanmar, Datasheet for gas-engine heat pumps, http://www.schwank.de/fileadmin/00_customer/documents/pdf/Brosch%C3%BCren_DE/Gasw%C3%A4rmepumpe_Datenblatt.pdf

Schweitzer, Jean, Frederiksen, Karsten og Jensen, Jan. Gasfyrede villakedlers virkningsgrad i praksis. *Gasteknisk Tidsskrift*. 2015, nr. 2.

Schweitzer, Jean og Christiansen, Christian Holm. Recent progress (and application) achieved in the way to estimate real performances of domestic boilers once installed. SAVE Workshop Utrecht. Utrecht: s.n., 2000.

Solar Thermal Barometer – EurObserv'er, May 2016, <http://www.eurobserv-er.org/solar-thermal-and-concentrated-solar-power-barometer-2016/>

Shell Deutschland, BDH, HHWI, iTG Dresden, *Shell BDH House heating study – Climate Mitigation in the Domestic Building Sector – How Will We Supply Heat Demands in the Future? – Facts, Trends and Perspectives for Heating Technologies towards 2030 (German title: Shell Hauswärme-Studie Klimaschutz im Wohnungssektor – Wie heizen wir morgen?)*, 2013, Shell Deutschland Oil GmbH, http://www.shell.de/promos/media/bdh-hauswarme-shell-studie/_jcr_content.stream/1455623261772/e8874e0ed5e3f0ef52c62a9ae674b5186d7b7bbd72351102fe0ff14f5c972a01/comms-shell-bdh-heating-study-2013.pdf

sirAdos-database for construction costs in Germany, www.baupreise.de, WEKA MEDIA GmbH & Co. KG, accessed September 2016, updated continuously.

Soares, S & Fragoso, R, *Energy Efficiency trends and policies in Portugal*, ADENE, 2015

SolarGIS, Global Horizontal Irradiation Map, 2014. Downloaded 19 December 2016. <http://solargis.com/assets/graphic/free-map/GHI/Solargis-Europe-GHI-solar-resource-map-en.png>

SolarVenti, Company Homepage, <http://solarventi.dk/anvendelser-luftsoelfanger-soelfanger-fritidshus-helaarsbolig-kaelder/energifanger-fra-solarventi-goer-jordvarmeanlaeg-billigere-og-bedre>, accessed November 2016.

Sousa, J ,et al., *Research on the Portuguese building stock and its impacts on energy consumption – an average U-value approach*, Archives of Civil Engineering, LIX, 4, 2013

Spring Solar, Company Homepage, <http://www.springsolar.hu/hw300-napkollektoros-hasznalati-melegviz-rendszer>, accessed June 2016

UMBW. Leitfaden zur Nutzung von Erdwärme mit Erdwärmekollektoren (engl: Analysis Report on the use of geothermal heat through heat collector technologies). Stuttgart: Environmental Ministry of Baden-Württemberg (UMBW), 2008.

U.S. Energy Information Agency (EIA) November 9th 2016, Updated Buildings Sector Appliance and Equipment Costs and Efficiency. <https://www.eia.gov/analysis/studies/buildings/equipcosts/> Accessed December 2016.

Vaillant Data: zeoTHERM Zeolith-Gas-Wärmepumpe. Bedienungsanleitung, Vaillant 2012 and Zeolith-Gas-Wärmepumpe zeoTHERM, Vaillant sales pamphlet, 2012.

Zöldparázs Kft., Company Homepage (in Hungarian), <http://www.cseresznye.net/arak/napkollektor-arak.html>, accessed June 2016

Zöldház Solar Kft., Company Homepage (in Hungarian), <http://www.zoldhazsolar.hu/arlista.php>, accessed June 2016

Appendix A: List of Abbreviations and terms

AC	Alternate Current
CHP	Combined Heat and Power
COP	Coefficient of Performance (mainly used for heat pumps in heating)
DC	Direct Current
DH	District Heating
EER	Energy Efficiency Ratio (mainly used for heat pumps in cooling)
EHP	Electricity-driven Heat Pump
FAME	Fatty Acid Methyl Ester
fc	Fuel Cell
GAHP	Gas Absorption Heat Pump
GCV	Gross Calorific Value
eng	Engine
GEHP	Gas Engine Heat Pumps
HP	Heat Pump
LPG	Liquefied Petroleum Gas
NCV	Net Calorific Value
NREAP	National Renewable Energies Action Plan
PEM	Proton Exchange Membrane
RES	Renewable Energies Share
SCOP	Seasonal Coefficient of Performance (mainly used for heat pumps in heating)
SEER	Seasonal Energy Efficiency Ratio (mainly used for heat pumps in cooling)
SHC	Solar Heating and Cooling
SOFC	Solid Oxide Fuel Cell
SPF	Seasonal Performance Factor
Woodchips	Chops of solid wood
Wood pellets	Mixture of sawdust or wood shavings and resin, typically between 5-14 mm in the longest edge.

GETTING IN TOUCH WITH THE EU

In person

All over the European Union there are hundreds of Europe Direct information centres. You can find the address of the centre nearest you at: <http://europa.eu/contact>

On the phone or by email

Europe Direct is a service that answers your questions about the European Union. You can contact this service:

- by freephone: 00 800 6 7 8 9 10 11 (certain operators may charge for these calls),
- at the following standard number: +32 22999696, or
- by electronic mail via: <http://europa.eu/contact>

FINDING INFORMATION ABOUT THE EU

Online

Information about the European Union in all the official languages of the EU is available on the Europa website at: <http://europa.eu>

EU publications

You can download or order free and priced EU publications from EU Bookshop at: <http://bookshop.europa.eu>. Multiple copies of free publications may be obtained by contacting Europe Direct or your local information centre (see <http://europa.eu/contact>).

JRC Mission

As the science and knowledge service of the European Commission, the Joint Research Centre's mission is to support EU policies with independent evidence throughout the whole policy cycle.



EU Science Hub
ec.europa.eu/jrc



@EU_ScienceHub



EU Science Hub - Joint Research Centre



Joint Research Centre



EU Science Hub



Publications Office

doi:10.2760/110433

ISBN 978-92-79-76014-3