

Technical University of Denmark



## Comparison of two- and three-compartment cells for electrodyalytic removal of heavy metals from contaminated material suspensions

Kirkelund, Gunvor Marie; Jensen, Pernille Erland; Pedersen, Kristine B.; Ottosen, Lisbeth M.

*Publication date:*  
2017

*Document Version*  
Peer reviewed version

[Link back to DTU Orbit](#)

*Citation (APA):*

Kirkelund, G. M., Jensen, P. E., Pedersen, K. B., & Ottosen, L. M. (2017). Comparison of two- and three-compartment cells for electrodyalytic removal of heavy metals from contaminated material suspensions. Abstract from 15th International Symposium on Electrokinetic Remediation, Montreal, Canada.

## DTU Library

Technical Information Center of Denmark

---

### General rights

Copyright and moral rights for the publications made accessible in the public portal are retained by the authors and/or other copyright owners and it is a condition of accessing publications that users recognise and abide by the legal requirements associated with these rights.

- Users may download and print one copy of any publication from the public portal for the purpose of private study or research.
- You may not further distribute the material or use it for any profit-making activity or commercial gain
- You may freely distribute the URL identifying the publication in the public portal

If you believe that this document breaches copyright please contact us providing details, and we will remove access to the work immediately and investigate your claim.

## Comparison of two- and three-compartment cells for electrodynamic removal of heavy metals from contaminated material suspensions

Gunvor M. Kirkelund<sup>1</sup>, Pernille E. Jensen<sup>1</sup>, Kristine B. Pedersen<sup>2</sup>, Lisbeth M. Ottosen<sup>1</sup>

<sup>1</sup> Department of Civil Engineering, Technical University of Denmark

<sup>2</sup> Akvaplan-niva, Norway

A new two compartment electrodynamic cell has been developed and patented at DTU (WO2015/032903 A1), seen in figure 1 together with the traditional three compartment cell.

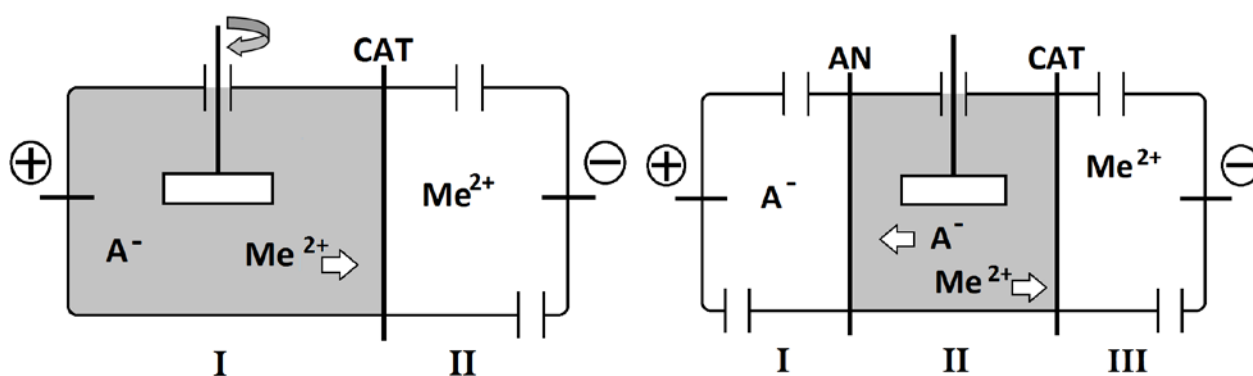

Figure 1. The experimental set-up of the two- and three-compartment electrodynamic cell. AN-anion exchange membrane, CAT-cation exchange membrane, A – anion, Me - metal.

The main advantage of the two-compartment electrodynamic cell compared to the three-compartment cell is the direct acidification by the anode in the material suspension. In the three-compartment cell, the acidification of the material suspension is caused mainly by water-splitting at the anion exchange membrane. The two-compartment cell set-up has been proven very successful for electrodynamic treating sewage sludge ashes, with transport of heavy metals to the catholyte and extraction of phosphorus, transported under the influence of the electric field to the anolyte. From the anolyte a very pure phosphorous salt can be obtained by filtration and evaporation (Ottosen et al. 2016). A further advantage of the two-compartment cell is the simpler set-up, which would mean lower costs for pilot scale trials and further industrial use. Therefore, it is interesting to investigate the efficiency for other materials with the two-compartment set-up and which of the two set-ups is most efficient for removing heavy metals from different contaminated particulate materials. In this study, the removal efficiency of As, Cd, Cr, Cu, Pb and Zn in the two different cell set-ups from several contaminated materials were investigated.

In total ten different samples (2 soils, 3 sediments, 3 ashes and 2 mine tailings) were used in the experiments. Two electrodynamic experiments were run for each material, one in both the two- and the three-compartment cell, totaling 20 experiments. All experiments had a duration of 7 days and

at a constant current. The current density was 0.2 mA/cm<sup>2</sup> for materials with low electrical conductivity (soil, mine tailing and lake sediment) and 1.0 mA/cm<sup>2</sup> for materials (fly ash, sewage sludge ash and harbor sediment) with high electrical conductivity to avoid water-splitting at the cation-exchange membrane. The material suspensions were made by mixing 100 g of dry material with 350 ml of distilled water. During the experiments, pH and electrical conductivity were measured daily in the material suspensions.

The results showed that the acidification of the material suspension occurred about one day earlier in the two-compartment cell for most of the materials. Also, a lower pH of a factor up to 2 in the suspensions could be reached in the two-compartment cell, influencing the release of heavy metals from the materials. The overall removal efficiency in the two-compartment cell was, however, not higher than in the-three compartment cell as seen in table 1.

<b>Two compartment most efficient</b>	<b>No difference</b>	<b>Three compartment most efficient</b>
<ul style="list-style-type: none"> <li>• Sewage sludge ash 1</li> <li>• Soil 1</li> </ul>	<ul style="list-style-type: none"> <li>• MSWI fly ash</li> <li>• Harbor sediment 1</li> <li>• Mine tailing 1</li> </ul>	<ul style="list-style-type: none"> <li>• Soil 1</li> <li>• Sewage sludge ash 2</li> <li>• Mine tailing 2</li> <li>• Harbor sediment 2</li> <li>• Lake sediment</li> </ul>

Table 1: Type of cell set-up resulting in the highest metal removal (%) for each treated material

It was observed that anionic metal species were not removed in the two-compartment cell, as up to 40 % of the metals were found in the suspension liquid phase; this was especially the case for chloride rich materials such as harbor sediments and fly ashes. Therefore, the removal was highest for most of the materials when using the three-compartment cell. The actual amounts of dissolved and removed metal for these materials in the two-compartment cell were generally higher than the removed and dissolved amounts in the three-compartment cell, since pH was lower.

This study showed that the removal efficiency between the two electro-dialytic remediation cells is dependent on the material that is subjected to treatment and should be taken into consideration when treated.

## References

WO2015032903-A1. Ottosen L.M., Jensen P.E., Kirkelund G.M., Ebbers B.E. Electro-dialytic separation of heavy metals from particulate material

Ottosen L. M., Jensen P.E., Kirkelund G. M. (2016) Phosphorous recovery from sewage sludge ash suspended in water in a two-compartment electro-dialytic cell. Waste Management , 51: 142-148.