



# Seismic Surge Wave Tank Team Final Report

Project Sponsored by: Santa Maria Discovery Museum

Cal Poly Senior Project Group:

David Streng:  
[dstreng@calpoly.edu](mailto:dstreng@calpoly.edu)

Jack Niemoller:  
[jneimoll@gmail.com](mailto:jneimoll@gmail.com)

Lisa Dischinger:  
[ldischin@calpoly.edu](mailto:ldischin@calpoly.edu)

Project Advisor: Dr. Davol

# Table of Contents

List of Figures	6
List of Tables	8
Abstract	9
Chapter 1: Introduction	10
Our Sponsor	10
Objective/Specification Development	10
Chapter 2: Background	12
Existing Products	12
Science Behind Waves	14
Chapter 3: Design Development	14
Mechanism Brainstorming and Decision Making	14
Plunger	15
Cam	16
Drop Tank	16
Piston	17
Chosen Design:	19
Actuator Design	20
Tank Design	21
A.	22
Tank Structure:	22
Dimensions	22
Material	24
B. Water Treatment:	26
C. Model Coastline:	26
Mechatronics Overview	28
Chapter 4: Final Design	29
Mechanism:	29
Description	29
Analysis Results	30
Cost	31

Selection Considerations	32
Maintenance	32
Electronics and Control System:	32
Description	32
Analysis Results	38
Cost	39
Selection Considerations	41
Testing	41
Safety Considerations	41
Manufacture	42
Maintenance	42
Coastline and Water Treatment:	42
Description	42
Analysis Results	42
Cost	43
Selection Considerations	43
Safety Considerations	43
Maintenance	44
Tank Body:	44
Description	44
Analysis Results	47
Cost	47
Selection Considerations	49
Safety Considerations	49
Manufacturing and Maintenance	50
Tank Support Structure:	53
Description	53
Analysis Results	54
Cost	54
Selection Considerations	54
Safety Considerations	54
Manufacturing and Maintenance	55

Chapter 5: Implementation and testing of the Wave Tank	55
Mechanism	55
Change in Design	55
Recommendations	56
Electronics and Control System	57
Change in Design	57
Recommendations	57
Water Treatment	60
Change in Design	60
Recommendations	60
Tank Structure	61
Change in Design	61
Recommendations	61
Coastline and Support Structure	62
Change in Design	62
	63
Chapter 6: Conclusion	63
Attachment A: Design Selection Documents	64
A.1 QFD	64
A.2 Preliminary Design Summaries	65
A.4 Pictures of Prototypes and Cam Testing	68
A.4 Design Matrix	68
Attachment B: Analyses and Specification	70
B.1 Vendor Supporting Data Sheets	70
B.2 Analysis for Final Design	72
B.2.A Electrical Analysis	72
B.2.B Tank Analyses	78
	79
B.2.C Coastline Analysis	80
B.2.D Support Structure Analysis	81
B.2.E Wedge Dynamics	82
Attachment C: FMEA	83

Attachment D: Estimated Bill of Materials	84
Attachment E: Gantt Chart	87
	88
Attachment F: References	89
Attachment G: Task Diagram and Finite State Machines	91
Attachment H: Drawings	95
Attachment I: Purchasing	158
Attachment J: Testing and Verification	159

## List of Figures

Figure 1: Flapper mechanism method to create deep ocean waves. <a href="http://www.edesign.co.uk/waves/some-wave-1/">http://www.edesign.co.uk/waves/some-wave-1/</a>	Pg. 12
Figure 2: Piston mechanism method used to push the entire water column. <a href="http://www.edesign.co.uk/waves/some-wave-1/">http://www.edesign.co.uk/waves/some-wave-1/</a>	Pg.12
Figure 3: Cartoon model of the plunger device's head as wave mechanism #1.	Pg. 14
Figure 4: Cartoon model of the Cam design as wave mechanism #2.	Pg. 15
Figure 5: Cartoon model of drop tank system as wave mechanism #3	Pg. 15
Figure 6: Cartoon model of piston plate as wave mechanism #4.	Pg. 16
Figure 7: The plunger mechanism as our chosen method to make a wave.	Pg. 19
Figure 8: The plunger mechanism in reference to the tank.	Pg. 19
Figure 9: Rough model of the overall tank display for the museum.	Pg. 23
Figure 10: Diagram that demonstrates how the geometry of the coastline affects the shape of the crashing waves. <a href="http://www.thegeographeronline.net/coasts.html">http://www.thegeographeronline.net/coasts.html</a>	Pg. 27
Figure 11: Example of a Coast line used in FIT's wave tank <a href="https://ecurrent.fit.edu/blog/campus/ocean-engineering-sciences/wavetank/cross-shore-sediment-transport-time-lapse">https://ecurrent.fit.edu/blog/campus/ocean-engineering-sciences/wavetank/cross-shore-sediment-transport-time-lapse</a>	Pg. 28
Figure 12: Wedge Assembly	Pg. 30
Figure 13: Upper Sprocket Assembly.	Pg. 30
Figure 14: Lower Sprocket Assembly.	Pg. 30
Figure 15: Electronics Assembly.	Pg. 32
Figure 16: Raspberry Pi 2 B.	Pg. 33
Figure 17: Raspberry Pi Touch Screen.	Pg. 34
Figure 18: Nema 23 Motor.	Pg. 34
Figure 19: St-M5045 Motor Driver.	Pg. 35
Figure 20: Cooler Master 80mm Fan.	Pg. 35

Figure 21: 5V Voltage Regulator	Pg. 36
Figure 22: Logic Level Converter.	Pg. 36
Figure 23: Full Wave Tank Assembly.	Pg. 45
Figure 24: Tank Assembly.	Pg. 46
Figure 25: Cross Sectional View of the Wave Tank Assembly.	Pg. 47
Figure 26: How Acrylic Fractures.	Pg. 50
Figure 27: Tank Assembly Reference 1.	Pg. 51
Figure 28: Tank Assembly Reference 2.	Pg. 52
Figure 29: Drain Below Coastline.	Pg. 53
Figure 30: Support Structure Assembly.	Pg. 54
Figure 31: revised electronics housing	Pg. 62
Figure 32: Nucleo shield	
Figure 33: PowerSTEP01 driver	Pg. 62
Figure 34: Trinamic Controller	Pg. 63

## List of Tables

Table 1:	List of customer requirements	Pg. 9
Table 2:	List of customer specifications	Pg. 10
Table 3:	Go/NoGo results of foam prototypes	Pg. 14
Table 4:	Rough Design Criteria for Design Matrix	Pg. 17
Table 5:	Rough tank load Calculation	Pg. 22
Table 6:	Cost Summary of Mechanism	Pg. 31
Table 7:	Summary of Trace Widths	Pg. 39
Table 8:	Summary of Wire Gauges	Pg. 39
Table 9:	Cost Summary of Electronics	Pg. 40
Table 10:	Coastline and Water Treatment Cost	Pg. 43
Table 11:	Tank Cost Summary	Pg. 48



## Abstract

The Santa Maria Discovery Museum would like to add a tsunami wave tank to be one of their demonstrations. The wave tank needs to draw the attention of their young crowd and be educationally informative about the shapes and effects of waves. As this is a museum demonstration for children, the structure, user interface, and wave making mechanism must be durable.

We are a senior project team from California Polytechnic State University that worked on this project with Allan Hancock College and Stanford University. We created waves by rapidly moving a plunger vertically in the water column. This project allows a user to select between two wave modes (single wave and continuous) and input a frequency and amplitude. Although the senior project is finished, there is still work that needs to be done before the display is ready. While part of this is further kid proofing and aesthetic improvements, there is still work to be done on the mechanism as well as the control software and hardware.

# Chapter 1: Introduction

## Our Sponsor

The Santa Maria Discovery Museum, in conjunction with Allan Hancock Community College and Stanford University, is currently developing a wave tank for a display in the museum. This tank would ideally show how both large and small waves travel and impact on a coastline. Since there are no commercial solutions available for this type of tank, one needs to be designed and constructed. After some prototypes, Allan Hancock College reached out to California Polytechnic State University at San Luis Obispo (Cal Poly) and sponsored a team of students to design and build this tank. This project is supported by the National Science Foundation (EAR-1255439, CAREER: Subduction Zone Hazards: Megathrust Rupture Dynamics and Tsunamis, Eric M. Dunham, Stanford University).

## Objective/Specification Development

The customer has specified the following objectives. The safety of its visitors, long runtime, minimal maintenance, and the ability to withstand abuse. The average age of the visitors is 4 years old, and the museum hosts a number of open houses and field trips, resulting in a visitor count that can total up to 1,000 people in a day. The safety of the visitors is the highest priority. Another main requirement, is that the system actually makes waves, since it is the initial purpose of this project. This means that the waves need to be large enough to see, this allows visitors to easily interact with the wave tank.

**Table 1: Customer Requirements**

Customer Requirements		
Museum	Visitors	Manufacturers
cost less than \$4500 Tank length cannot be greater than 20 ft. Cannot Tip Easy to maintain Demonstrates waves crashing on a coast line Visitors to interact with system Position Lockable	system is safe waves are viewable connects visitors to action	Easy to Build Easy to Maintain Movable from Cal Poly to Museum

**Table 2: List of Specifications**

Specifications	
General	Detail
Cost	less than \$4500
Size	Less than 20 ft. long, between 4 and 8 inches wide
Safety	Can handle 15 kids hanging on odd edges and is tough for students less than 4 ft tall to climb on top of
Creation of waves	Frequency up to 1/30 hz, amplitude increase up to 50%
Visitor interaction	visitors need to trigger the waves
Duration	works about 78 hrs/week
Viewability	Wave window should be about 3 ft. above the ground

A Quality Function Deployment (see Attachment A) was used to compare and contrast our customer's requirements and wants.

QFD matrices are a powerful planning tool frequently used in product development. The left side, under "Requirements" lists customer requirements for the product (such as safety). The top middle, under "Measures" lists quantifiable specifications that are used to measure the customer requirements (such as size) while the bottom middle in the "Targets" section lists exact specifications for the measures (such as the product will not exceed 20 feet in length). The middle of the matrix correlates the requirements to the specifications (for example, there is a strong correlation between size and cost)

# Chapter 2: Background

## Existing Products

To construct a wave tank from scratch requires the group to have knowledge of how a wave is created. Therefore, it is imperative to understand the mechanics of waves and the various ways in which a wave can be propagated. The general composition of all the waves that we researched consist of four different wave producing mechanisms. One is a water pump that “drops” water from a reservoir above into the wave tank through a controllable gate. Another is a flapper device that acts as a pendulum to displace water. Yet another is a horizontal panel that translates back and forth, often called a piston mechanism. Finally, a plunger that vertically oscillates within the tank. All of the solutions above provide clear visual understandings of wave propagation.

The use of water pumps and dropping reservoirs are used by many waterparks and are more tuned to larger scale, low frequency wave generation. It incorporates collecting and pumping water into a sump positioned above the elevation of the water level in the tank in which the wave is to be propagated. Then a controllable gate is opened that allows the water in the sump to drain into the tank at the highest possible flow rate. As a result, one large wave is sent out across the tank. This type of system has several drawbacks including, the size of the mechanism required, cost of components (i.e. pumps, valves, lines, etc), reliability, and most importantly the frequency of wave generation. This system is feasible on a small scale, however it is better suited for larger setups. Additionally, knowing that this wave tank is meant to be a visual phenomenon to be viewed and interacted with by children, a fast, repeatable, and entertaining wave generating device is optimal.

In large scale commercial wave tanks, such as those used in testing ships and offshore structures, the flapper and piston are the most common designs. The flapper mechanism (See Figure 1) consists of a plate pinned at its bottom like an inverted pendulum. The mechanism is rotated about the pivot point to displace water. This type of mechanism is typically used to create waves that are encountered in deep ocean waters. The piston mechanism (See Figure 2) relies on a vertical plate positioned in the water. This plate is driven back and forth to create a wave. This mechanism moves the entire water column and is used to replicate shallow water waves that are found near the shore. It's also a common practice to combine the two, with the flapper mechanism being used for the vertical plate in the piston mechanism. This allows the mechanism to create any arbitrary wave that is a combination of shallow and deep water waves. These wave tanks can be extremely complex with dozens of mechanisms and advanced wave generation and absorption software. This type of tank can create a wide array of extremely elaborate conditions. The figures below are courtesy of Edinburgh designs, a commercial wave tank design company based out of England. They show the flapper and piston mechanisms.

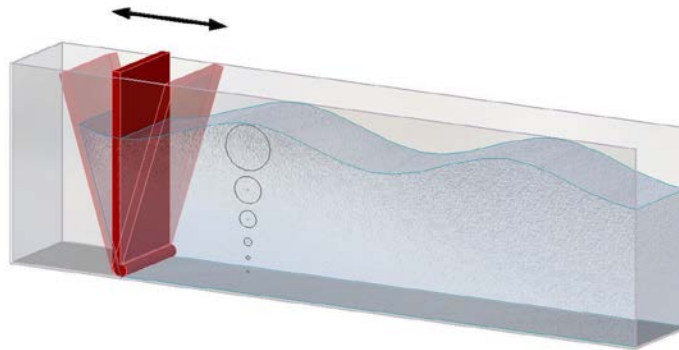

Figure 1: Flapper Mechanism  
Edinburgh Designs  
<http://www.edesign.co.uk/waves/some-wave-1/>

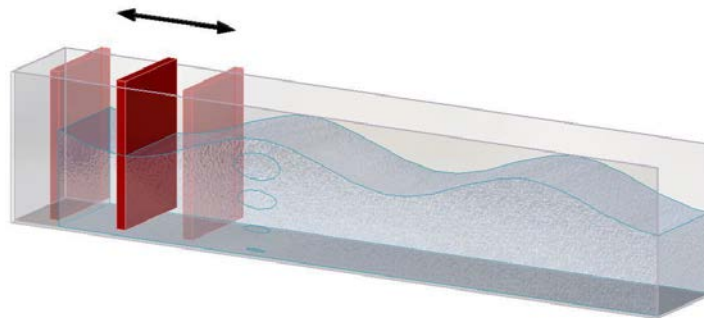

Figure 2: Piston Mechanism  
Edinburgh Designs  
<http://www.edesign.co.uk/waves/some-wave-1/>

For the plunger mechanism, a piece of material (typically a triangular prism or quarter ellipsoid) is moved vertically in the water column. This mechanism excels at making smaller shore waves and sees use in large aquariums such as the Monterey Bay Aquarium.

## Science Behind Waves

Waves travel in a few different ways, depending on the type of wave being propagated. In the ocean and other larger bodies of water, waves travel on the surface. The water particles within each successive wave crest travel in a circular motion relative to the wave crest. This causes the waves to travel longitudinally across open water due to direction of the momentum from the circular motion of the particles. It can be seen in the previous figures, that there are oval shapes beneath the wave crests. This demonstrates the circular motion that the water particles undergo to cause the wave to propagate.

## Chapter 3: Design Development

### Mechanism Brainstorming and Decision Making

This following chapter was written as our preliminary design review and shows our process of arriving at our final design. There are a lot of speculations that we have later debunked

We did a series of brainstorming sessions that included rapid Post-it note ideation to telephone lists of ideas. We also have been lucky enough to receive a test tank and be able to quickly test out rough prototypes and ideas. We split up our design into two main components; the overall method of creating the wave (what we call the mechanism), and the system that is used to create that method of wave (the actuator). At this point, we are focusing solely on the mechanism as the actuator depends upon this.

Our brainstorming sessions left us with a wide scope of ideas that ranged widely in practicality. The first step in our selection process was to narrow down the results of our brainstorming sessions. Because of the nature of our brainstorming methods, several of our ideas were similar and we were able to condense the number of ideas into a more manageable number.

The next step was to construct quick mock ups of our ideas. This served two purposes; first it eliminated the least feasible ideas as we were unable to create mock ups of these ideas, secondly we were able to personally see the types of waves created by each mechanism. These models were subjected to small scale testing to determine their effectiveness. The results of these tests were evaluated using a Go/NoGo method. A Go means that the idea is plausible and warrants further development, while a NoGo immediately eliminates the idea. The results of this exercise are summarized in the table below.

**Table 3: Go/NoGo results from our first foam prototype tests**

Foam Prototypes tested in first Tank trial	
Idea	Go/ NoGo
Wedge/Plunger	Go
Cam	Go
Dolphin Tail	No Go
Water Drop	Go
Large Air Burbuja	No Go
Water Wheel	No Go
Piston/ stright pusher	Go
Hinge Paddle	No Go

We decided that the Plunger, Cam, drop tank, and piston warranted further development. These mechanisms are explained in more detail later on and in Attachment A, the Preliminary Design Summaries.

## Plunger

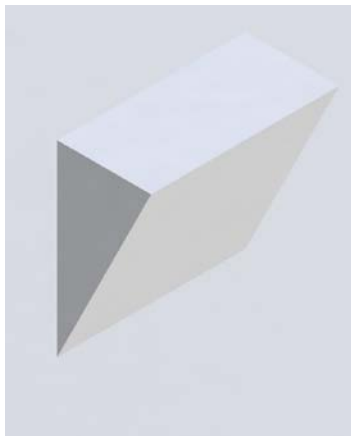

Figure 3: Plunger Mechanism

The plunger mechanism works by moving a mass vertically in the water; this motion displaces water to create a wave. Although this method is not used by many wave tanks, this mechanism has been used by aquariums, such as the Monterey Bay Aquarium, to create full scale coastal waves. When scaled, this mechanism will allow us to produce large, visibly appealing waves at high frequency. For single waves, the best performance was obtained by slowly lowering the plunger in, and then rapidly removing it. For the best effect, we would want to use a large plunger.

## Cam



Figure 4: Cam Mechanism

The Cam mechanism can be seen as a rotational version of the plunger. As the cam rotates, it displaces water to create a wave. This mechanism created adequate waves in the small scale test, but underperformed compared to some of the other mechanisms. It is important to note that the mock up for this model was significantly smaller than some of the other mechanisms. Because of this, we decided to advance this design to see if a larger cam would perform as well as the other mechanisms. Since the cam shape is highly important for this mechanism, we made several different cams and further tested their wave making capability in our second tank test. The results from this second test will be described later on.

## Drop Tank



Figure 5: Drop Tank mechanism

At its core, the drop tank involves pumping water to a separate sump stored above the main tank. When full, this tank is rapidly drained into the main tank. Several smaller sumps (shown in the picture above) may be used in order to increase the maximum frequency of the tank. This type of mechanism is commonly used in water park wave pools. One advantage of this mechanism is that it accurately replicates a Tsunami wave. However, this mechanism is slow



compared to the others and is the most complex and is difficult to waterproof due to its large moving sealed surfaces.

## Piston



Figure 6: Piston Mechanism

For the piston mechanism, a vertical plate is moved back and forth horizontally in order to push the water forward and create a wave. It is the only mechanism that moves the entire water column, this helps with wave formation as the water depth decreases. However, this mechanism requires a larger force to operate as it must act against the hydrostatic force. This mechanism is widely used in commercial wave tanks for testing ships and coastal structures.

We created a design matrix, to evaluate the effectiveness of each of our mechanisms (see Attachment A). In a design matrix, a list of criteria is created and each criteria is assigned a weight on a scale of 1-10. Then each design was assigned a score of 1-10 based on how well each design meets the requirements. Our criteria and weights are summarized below

**Table 4: Design Criteria**

Criteria	Weight	Explanation
Child Enthusiasm	7.5	Given that this is for a children's museum, the wave tank needs to be entertaining to the visitors
Safety	4	Although safety is very important, all our mechanisms will be safe in normal operation. We focused primarily on critical failure and secondary concerns such as water proximity to electronics
Charge rate	6	The charge rate is a measure of how quickly the mechanism can create a wave right after it had already created a wave
Force needed	3.5	Although a lower force is ideal, the needed force isn't significant at this scale
Complexity	7	The complexity is very important as it affects the required maintenance and other criteria such as durability and waterproofing
Ease of waterproofing	7	Our wave tank must be completely waterproof and our mechanism affects how easy that is to accomplish
Durability	8.5	Our mechanism must function constantly and be able to withstand abuse. Our design should also require as little maintenance as possible
Compactness	2	Our design shouldn't take up too much space
Cost	5	All of these mechanism can be successfully made within our budget so this criteria is only of medium importance
Engineering pride	3.5	As this is our senior project, we want a design that showcases our abilities
Manufacturability	6	Our design should use as many 'Off the Shelf ' parts as possible and be easy to build, as maintenance and repairs will be made by museum staff
Wave size	3.5	Since the beach will be scaled, it is not necessary to create a massive wave

Partway through our decision matrix, it became clear that the Piston and Drop Tank did not meet the requirements as well as the others. The Cam and Plunger advanced to our next stage of testing.

Alan Hancock Community College provided us with an 8-foot tank from their initial prototypes and we used this tank to conduct larger scale tests. One of the main goals of our second tank test was to properly evaluate the cam mechanism and determine the effect of cam shape on the wave (see Appendix A for sample Cam designs). We also compared these results to a scaled up version of the plunger mechanism, the front runner at this point. We were unable to determine the effect that the cam shape has on the wave, but we successfully tested a larger scale cam. Although the cam did create passable waves, the plunger mechanism created larger waves that were more entertaining to watch. Also, the plunger drastically outperformed the cam in single wave performance. The cam just was not able to displace the same amount of water as the plunger. This seems to be inherent with the cam design and not a problem with the geometry.

## Chosen Design:

Based on our second round of testing and decision matrix, we selected the plunger mechanism for our final design.

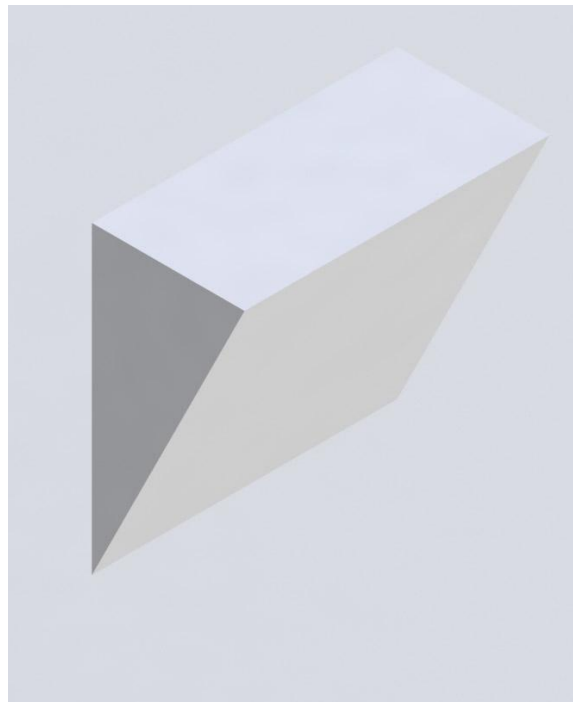

Figure 7: plunger mechanism



Figure 8: Plunger mechanism in tank

This mechanism proved to create large high frequency waves with a minimum of input force, and also produced the best single wave out of all of the tested mechanisms. It's also a very simple mechanism that's easy to waterproof. In small scale testing, this mechanism had issues with standing waves. This is something that we will need to investigate and avoid when moving forward with this mechanism. This means that we will just need to find the right frequency of wave input and that our coast line will need to be dampen the back flow. This mechanism tends not to make realistic Tsunami waves however. This is because the mechanism does not move the entire water column, something that is notable about coastal waves. Instead it moves part of the water column, a feature more commonly found in deeper ocean waves.

## Actuator Design

First, we wanted to iron out the details of how we wanted to create a wave before we figured out how we want to actuate and move that wave mechanism. Once we decided to use a plunger like mechanism we were now able to better brainstorm what actuators could provide that motion. We have a general list of actuators that could provide this vertical linear motion and this list is below along with their pros and cons.

- Rack and Pinion
  - + Very robust
  - + Easy to control location output
  - + Rigid motion
  - + Multiple speeds and output locations
  - Does not have a quick impact reaction
  
- Electrical Solenoid
  - + Strong and quick action
  - + Direct motion of what we want
  - Usually has small throw of action
  - No positional control
  
- Hydraulics/Pneumatics
  - + Very strong and very quick in actuating
  - + Hydraulics are not as affected by water
  - + Quick repeated action
  - Very expensive
  - Are made up of a large system just to support the pistons
  - High Maintenance
  - Not as easy to control position
  
- Four Bar Linkage and Motor
  - + Can be used to increase power and torque from a weak source
  - + Further removes electrical system from possible water conditions
  - Position is tough to control as it is dependent upon geometry and dynamics
  - Would need to fully constrain motion of the linkages

## Tank Design

There are three main aspects to the tank design; the tank structure, the water treatment system, and the coastline within the tank. A lot of consideration needs to go into cost of material, cost of maintenance, ease of maintenance, and durability. We will need to do a lot of testing with different materials and geometries to find out which works best for our final tank.

A.

### Tank Structure:

#### Tank Specifications:

- Overall length is less than 20 feet
- Tank structure can be securely locked to a wall
- Tank can easily be drained and cleaned
- Tank is extremely hard to tip over
- Wave viewing section can be easily viewed by visitors ages 4-10

Later on we will go over our structural and material considerations for the tank structure, and the expected testing that we will use to finalize our design. We do not have a lot of previous experience with building tanks, therefore we want to practice building tank walls and test a couple of materials in long water exposure.

#### Dimensions

A longer length of a tank allows for more waves to build up and to really crash onto the shore line. The depth of the water, which is not the same as the height of the tank, affects the size and speed of wave that is created. The height of the tank needs to be at least twice the nominal depth of water. The width of the tank effects stability and wave flow. A wider tank is more stable, but increases the 2-D effects. Additionally, the larger the tank, the more water it holds which makes it heavier and applies higher loads onto the overall structure. All of this will be further considered in the text below.

We have assumed that we will only need a nominal water height of 12-18 inches, this will be of sufficient depth to create a wave and still be fully viewable by young visitors. With this in mind, we did some quick calculations of the water volume and the static pressure seen on the tank walls. These calculations and variations can be seen in Table 5 below.

**Table 5: Rough Calculations of Tank Dimensions Affecting Tank Static Loads**

Basic Tank Pressures and Volumes based off of different dimensions						
Length [ft]	Width [in]	Height [in]	Volume [gal]	Weight [lbf]	P_Bottom[psi]	P_wall_max[psi]
18	6	12	67	559	0.43	0.43
18	6	18	100	839	0.65	0.65
18	8	18	134	1118	0.65	0.65
19	6	12	71	590	0.43	0.43
19	6	18	106	885	0.65	0.65
19	8	18	141	1180	0.65	0.65

\*Water Density [slg/ft<sup>3</sup>]: 1.931

These pressures represent the pressure exerted on the bottom of the tank by the weight of the water, and the hydrostatic pressure exerted on the wall by the water.

We did not want our tank of water to be the full 20 feet since we need some space for structure and for the wave making mechanism. Thus we decided that a water tank length of 18 feet will be a good starting estimate. We also decided that having a width of 6 to 8 inches is a good value to start off with. If we make the tank too wide, we will have more water but there is less of a concern with edge effects disrupting the creation of the wave. While having too thin of a tank does help the flow resemble a 1D flow, where wall effects cancel each other, but then the tank is easier to tip. As for the height choices, the deeper the nominal height, the larger the waves we are able to make. This is all for the awe and wonder of the visitors, and the bigger the wave, the more interested they will be.

Doing the analysis above, eased some of our concerns with the load on the tank bottom. We were concerned about the normal and shear stresses in the tank material, and the maximum pressure applied to the material is under 1 psi. As long as the tank has multiple supports underneath the tank our structure should be able to easily handle the applied loads. This analysis also clarified the amount of water we are using. These numbers will be important for our final analysis for the water treatment segment.

As the tank will be relatively thin, we want the structure of the chassis to be tough to tip over and tough to climb onto. Thus the structure around the tank will need to not have easily grab able edges and to have a base wider than the water tank to prevent any possible tipping. Ultimately, the design of the structure was determined to be outside the scope of this project and left to Alan Hancock College and the Santa Maria Discovery Museum, however we provided them with a suggested stand. The general structure will look something similar to the figure below.

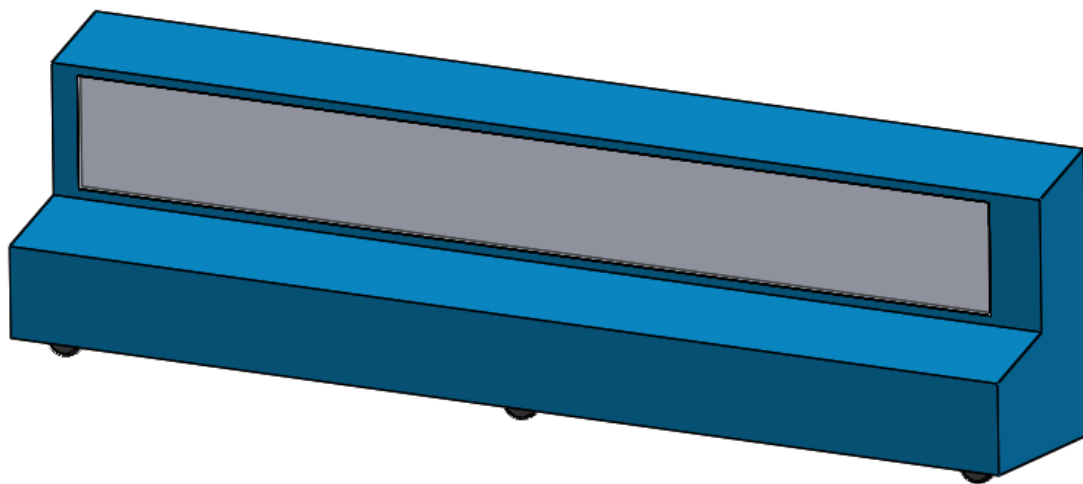

Figure 9: Rough model of the overall tank display

To address the ease of maintenance and cleaning of the tank, we have decided that our tank chassis will be on wheels, so that the tank can be easily transported to the correct drain, and outdoors where it can be cleaned. It was also an added desire of the museum to cart the tank outside during their large open house days. To maintain safety, the chassis will still be locked to the wall during its display within the museum, but it can be detached and carted outdoors where its wheel will be locked. When we visited the museum, we ensured that they would be able to easily move the tank. The museum has a very large roll up door that our tank will easily be able to get in and out.

Working with our practice tank will give us a better idea of some of the concerns that we will face in implementing our desired actuator with the water tank. We have been given extra sheets of acrylic for prototyping. These considerations will all go into the design of our final tank.

### Material

The main materials that we need to be concerned with is the window material (in how much it costs and its durability), the sealing system (whether it can be reapplied multiple times), base sealant, and structure material.

For the window, we want it to be clear and be resistant to scratches and impact. If it were to get damaged, it must not fail catastrophically, such as glass shattering. Below is the main list of candidates for our window material along with their pros and cons.

- Tempered Glass: Glass used in showers, store windows
  - + About 4x stronger than regular glass
  - + It shatters into small, non-sharp pieces
  - + Scratch resistant
  - When it breaks, it crumbles, catastrophically failing
  - More susceptible to breaking with edge defects
  - Moderately expensive
  
- Cast Acrylic: Commonly used in Aquariums
  - + Stronger than glass
  - + Can be strongly welded together
  - + Already have large sheets of this
  - + Not as brittle as glass
  - Not scratch resistant
  - Expensive
  
- Polycarbonate: material used for police riot shields
  - + Will not shatter
  - + Can be strongly welded together
  - + Very safe
  - Expensive



- Not scratch resistant

We ultimately decided to use Acrylic. This material is between glass and polycarbonate in that it is not the easiest to break and is not the easiest to scratch. It is not the best of either of those traits, so we might decide that it will be better to go with either glass or polycarbonate.

There are two main tank structures to consider. The first is a homogeneous tank that consists of only one type of material. If this is acrylic or polycarbonate, we can permanently weld the sections together creating a unibody construction. If we use multiple materials for different parts of our tank, such as an acrylic front and plywood back, then we have to use other methods of waterproofing.

- Caulk: sealant applied to gaps in material
  - + Easily able to be added repeatedly until there were are no more leaks.
  - + Cheap and versatile
  - + Easy to apply
  - + Can be bought at any hardware store
  - Not the most aesthetically pleasing on the edges
  - Needs to be peeled off and redone every time a side is replaced
  - Could possibly wear or “relax” as frame shifts
- Gaskets: Rubber sheet that is wedged between surfaces
  - + Reusable
  - + Cleaner and easier to hide
  - + Only releases seal when surfaces are loose
  - If there is a leak, the only way to fix leak is to apply more clamping pressure at the leaking point
  - Tough to initially make
  - More expensive upfront cost

For the purposes of ease of maintenance for the museum staff, we are leaning towards caulk sealed between two surfaces, since that can be easily bought and applied, and it can be done in such a way that it is not readily visible to the public.

Since we will not have all the walls of the tank be windows, we need to find a good structural material to for the remaining walls. It will be cheapest to do so with wood panels that are coated. Plastics are tough to secure to and do not have as great of a specific strength, though they would see no corrosion or leaking from the water. A metal would be strong enough, but incredibly heavy and would need to be coated also to protect it from corrosion. Wood has a good enough specific strength for our purposes and can be easily coated. Coated wood is the method used often for large tanks.

## B. Water Treatment:

The fluid in the wave tank system requires some level of water treatment in order to prevent bacteria from accumulating over time within the tank. A quick and simple solution would be to regularly drain and replace the water. However, we also want to minimize the number of service hours required to keep this wave tank operating. There are several routes to take to accomplish this. One method would be to have a fluid medium that prevents bacteria from growing, such as mineral oil. Another option is to chemically treat the water with biocides. All of these solutions work but the ultimate goal is to minimize the cost and number of maintenance hours while maximizing tank cleanliness.

The solution that best address the water treatment requirement is the option to incorporate a fluid that doesn't need to be replaced. This requires the least amount of maintenance time since the fluid, in theory should never need to be replaced. In comparison to the option to replace the water every few days, using antibacterial fluids represents a clear reduction in maintenance. However, these materials need to be fairly cheap in order to make the cost worthwhile.

Several options were researched for antibacterial fluids. Namely being mineral oil, biocides, and sodium citrate silver nanoparticles dissolved in water. After investigating each, it turns out the required amount of mineral oil needed would cost an enormous amount in upwards of \$800. If biocides were used to treat the water, they would have to be continuously replenished over time. However, the cost to implement silver nanoparticles in a wave tank of our size would cost approximately \$50, and in theory, it would be a onetime fee since they have a near infinite life. The concentration required for our tank to be effectively antibacterial would at a minimum 5mg sodium citrate silver nanoparticles per the entire volume of the tank. Though this does not account for the amount that might be absorbed into the coastline or other tank materials. The materials required to synthesize silver nanoparticles are readily abundant as well, hence the cheap cost. Additionally, these particular pre-synthesized silver nanoparticles may be bought off the shelf if more are needed. The only downside with these is that they might not be allowed to be poured down a drain, but the EPA has not yet stated a regulation against it. However, considering the cost and maintenance required for each fluids upkeep, and unlikelihood of needing to replace the water, silver nanoparticles provide the most feasible option for this wave tank. Moving forward, various concentrations of sodium citrate silver nanoparticles will be tested and analyzed over the long term for bacterial growth, so that we can confirm the required concentration needed.

## C. Model Coastline:

The coastline, also referred to as the beach, in our tank has two primary requirements. The primary goal of the beach in any wave tank is minimize the reflection of waves off the end of the tank. This is primarily accomplished by careful design of the beach, material selection, and surface treatment. It's important to note that wave absorption doesn't appear as effective as it really is. Absorbing 90% of the energy in a wave will only reduce the wave amplitude to 31% of

the original size. As this tank will be located in a children's science museum, the beach must be visually appealing and entertaining as well.

The angle at the waterline plays an important role. The steepness ratio is fairly well optimized in industry; the optimal steepness ratio is between 1:6 and 1:10 at the waterline. Beaches that have an overall length of less than approximately 50% to 75% of the wavelength tend to hit a minimum of 10% reflection. Additionally, we would like to demonstrate wave shoaling, the process in which waves grow as they reach shallow water. Because of this, our beach should have multiple heights and slopes.

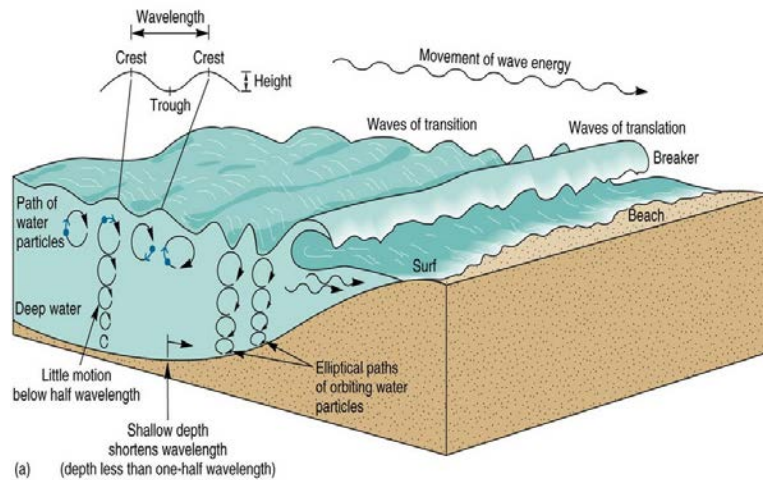

Figure 10. Diagram of how the coastline geometry affects the shape of the waves  
<http://www.thegeographeronline.net/coasts.html>

A highly porous material is needed for the beach as this allows the water to dissipate without adding to the reflected wave. Additionally, a high surface roughness is desired to encourage wave breaking. The process of breaking sheds a lot of energy from the wave and allows more water to absorb into the porous beach. A bulk solid beach (such as sand) should be avoided for this type of beach



Figure 11: Example of a coastline used in Florida Institute of Technology's wave tank

This part of the tank is extremely important and will need extensive testing. Scale testing for beaches is difficult as the wave absorption properties depend on the Reynolds number of the fluid. This fluid property depends on the position along the beach so changing the size of the beach will change how the fluid behaves.

## Mechatronics Overview

The mechatronics for this project can be split up into three main parts, the user interface code, the control code, and the hardware.

The graphical user interface (GUI) has been provided by Alan Hancock Community College. It's currently written in Java and will need to be modified to run on the hardware and run in conjunction with the control code.

The control code is being written as part of this senior project. It will need to communicate with the GUI to receive wave instructions and control the actuator. Currently this program is being designed in micropython, however, that is subject to change if necessary.

Alan Hancock provided us with a stepper motor, a stepper motor driver, an AC/DC converter, a Raspberry Pi microcomputer, and an Arduino microcontroller. As our control code is likely to be fairly simple, both the control code and GUI will be run off of the Raspberry Pi initially. If our control code needs to be more complicated, the control code will be moved to the Arduino. The stepper motor is still being evaluated and we currently don't know if it will meet our needs, additionally an encoder may be added to the motor if closed loop control is needed. Additional electronics will be needed to complete the overall mechatronics package. This will include items like cooling fans, voltage regulators, and logic circuitry.

## Chapter 4: Final Design

The following chapter details our final design as of our design review. The changes have been documented in chapter 5. The final costs in this chapter show our estimates as well. Please see attachment I for our total cost.

### Mechanism:

#### Description

The mechanism contains the physical mechanical components responsible for generating waves. The mechanism utilizes a stepper motor that drives a belt fixed to a wedge, which allows for it to oscillate up and down within the water. The mechanism can be divided into two subassemblies. First is the wedge subassembly, which contains a two-piece wedge, two guide rails, and two thin pieces of sheet metal. The other subassembly consists of the belt, upper and lower sprockets, and stepper motor itself.

#### **Wedge Subassembly**

The wedge itself is made of acrylic and comes in two pieces, which are connected by a thread bolt and nuts on each side. On the back side of the wedge, two pieces of Aluminum 3003 sheet metal are bolted into the wedge, and contains a profile that allows for the belt teeth to mesh and be pinched by the sheet metal. This sheet metal design ensures the belt is rigidly connected to the wedge. There are also two acrylic guide rails that ensure the wedge follows a uniform vertical motion as it oscillates. These guide rails will be Gorilla glued to the interior of the tank itself.

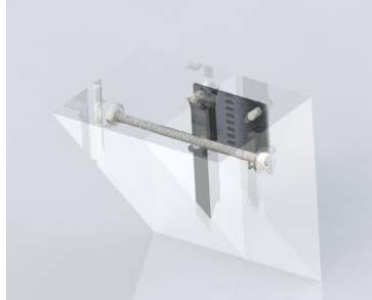

Figure 12. Wedge Assembly

### **Sprocket and Driver Subassembly**

The sprocket and driver subassembly consists of a Nema 23 stepper motor, upper sprocket system, lower sprocket system, and a timing belt. The belt is made from both neoprene and nylon and contains trapezoidal teeth. The upper sprocket system contains a 1.273 inch diameter 20 tooth D shaft pulley made of aluminum, the Nema 23 motor, and a steel bracket for mounting the motor. The upper sprocket brackets are bolted down into an Aluminum sheet metal support that is connected to the tank itself.



Figure 13. Upper Sprocket and Driver Assembly

The lower sprocket assembly consisted of a free rotating pulley mounted to a  $\frac{1}{8}$  inch ABS plastic shaft. This shaft is mounted to a pair of brackets using waterproof bushings. The brackets will be bolted to the tank bottom utilizing gaskets to create a watertight seal.



Figure 14. Lower Sprocket Assembly

### **Analysis Results**

Due to the low force requirements of our system, analysis for fatigue loading on the shafts, and overall stress analysis were neglected. However, to ensure the stepper motor used for this system was adequate, analysis for the maximum theoretical torque required of the motor was calculated. It was assumed that the maximum loading condition on the motor occurred when the

wedge was fully out of the water. Based on a wedge being made of acrylic, the maximum Force required to operate the wedge equated to 0.1 Nm, which was significantly less than the maximum motor torque of 125 Nm. This analysis can be seen in Attachment B.2.E.

## Cost

The following table presents a summary of the mechanism cost. For the full BOM, see Attachment D.

**Table 6. Cost Summary of Mechanism**

<b>Part</b>	<b>Quantity</b>	<b>Cost (\$)</b>
belt	1	6.43
Pulley, D shaft	1	15.53
Pulley, Free	1	6.2
ABS rod	1	2.5
Bushings	2	3.62
Bracket material	1	11.05
Bolts 1.5"	1	6.89
Guide rods	1	1.62
Bottom screws	1	7.59
Stainless hex screws	1	3.71
Aluminum sheet	1	6.36
Motor bracket	1	6.36
Corrosion resistant rod	1	2.04
nuts	1	3.76
Total Cost (\$)		84.09

This cost is subject to change. These prices are not necessarily the lowest and we have yet to select suppliers. Additionally, these prices do not include shipping costs.

## Selection Considerations

Acrylic was selected because it has a density close to that of water, requiring less work to need to be performed by the motor. It's also waterproof, and easily machinable. Many of the remaining components were selected for simplistic manufacturing reasons, as well as cost, and corrosion resistant material properties. Safety considerations for mechanism failure are mentioned in the FMEA Report in Attachment C.

## Maintenance

Routine maintenance will not be required the mechanism assembly. However, if a component on the assembly breaks, replacements will be able to be purchased off the shelf. Replacing parts will require basic knowledge of hand tools.

## Electronics and Control System:

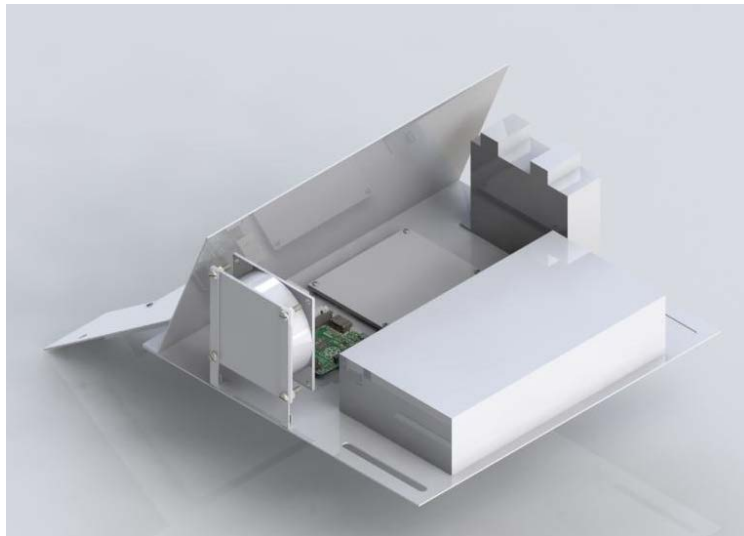

Figure 15. Electronics Assembly

## Description

The electronics consist of a power supply, support board, stepper motor driver, motor, processor and cooling fan. When applicable, data sheets will be provided in Attachment B.1, however not all of the suppliers supplied data sheets or they were too long to be shown in full.

A Raspberry Pi 2 Model B microcomputer will be used as the processor. It has a 900 MHz quad core processor and 1Gb of RAM. This will be enough to run both the programs and the display. The Raspberry Pi is only designed to run off of a clean 5V power supply. Because of this, the support board will need to utilize bypass capacitors to clear noise and provide a stable voltage.





Figure 16. Raspberry Pi 2 B  
raspberrypi.org

The official Raspberry pi 7" touchscreen will be used to interact with the end user. This screen uses a DSI cable to interface with the raspberry pi and the touchscreen uses i2c communication protocol. For power, this screen interfaces with the 5v supply from the raspberry Pi. The pi and screen have a combined power draw of 2.5 A.



Figure 17. Raspberry Pi touchscreen  
element14.com

A Nema 23 570 oz-in stepper motor was selected for this project. It requires a 24V power supply and draws 3.5A. This motor is more than capable of supplying the torque required by the mechanism. A ST-M5045 driver was selected to drive this motor. It can run stepper motors at 24-50 V with an output current of 1-4.5A. For this setup, the driver will be supplied with 24V and will draw 3.5A. Additionally, this motor driver contains onboard logic that simplifies the software driver.



Figure 18. NEMA 23 motor  
Automation Technologies Inc.

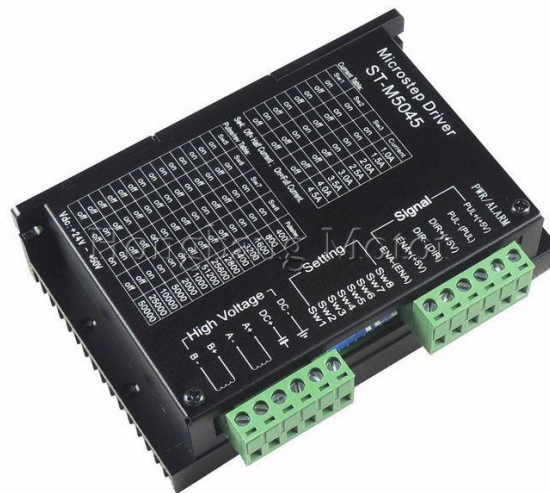

Figure 19. St-M5045 motor driver  
aliexpress.com

A generic 120VAC to 24VDC voltage converter was provided to us by Allan Hancock College. Although we were unable to find the make and model of this part, we were able to determine that this motor can supply up to 15A at 24V. This is well above the demands needed by the electronics (approximately 6A).

A cooling fan has been added to ensure that all the electronics are kept cool enough. An 80mm PC case fan has been selected as these fans are readily available. These fans run off of 12 volts and at this size draw approximately 6 mA.



Figure 20. Cooler Master 80 mm fan  
Newegg

The support board is the central hub of the electronics (a schematic and board drawing are available in Attachment H). It makes sure each component is receiving the correct type of power and facilitates communication between all the parts. It contains the following components

The support board needs to turn the 24V signal into a 12V and 5V signal. To do this a pair of step down voltage regulators will be used.



Figure 21. 5V Voltage Regulator  
Pololu Robotics and Electronics

The 5V line will also need to supply “clean” (free of AC signals and voltage changes) power. A pair of capacitors will short AC signals to ground and provide a stable voltage. Industry standard values of 10uF and 0.1uF will be used.

The Raspberry Pi operates on a 3.3V logic system while the stepper motor driver operates on 5V logic. In order to facilitate communication, a logic level converter will be used. This is a commercially available part that will convert logic signals between two voltages.

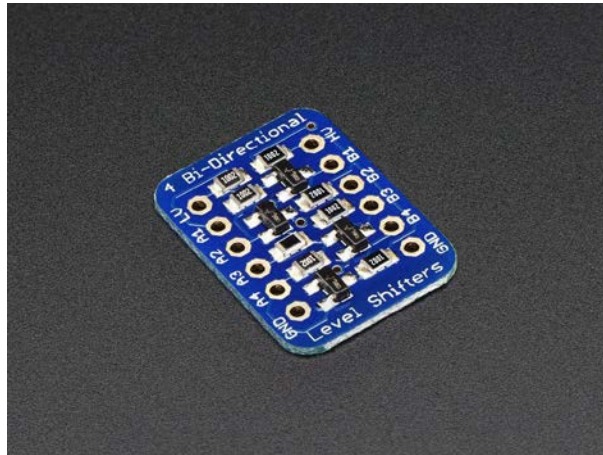

Figure 22. Logic level converter  
Adafruit

The 24V line will also utilize a pair of bypass capacitors to provide the motor with clean power. Additionally, although only one fan is currently used, the support board has support for two fans.

A mechanical assembly was designed to hold all the parts and allow for easy attachment to the frame (see Attachment H for drawings). 16 Gauge aluminum sheeting will be used to construct this assembly. The assembly consists of 4 parts. A base plate has attachment points for all the electronic components as well as the other assembly parts. It also has mounting points for the frame. A pair of display mounts hold the screen in place and attach to the armrest. Similarly, a pair of fan frames hold the fan in place. Finally, a protector plate is designed to protect the electronics from liquids spilled on the armrest. The assembly parts will be riveted together and the assembly will be bolted to the frame.

The control program is responsible for taking commands from the GUI program and making sure they are executed. The GUI and control programs will communicate with each other over a virtual serial port. The GUI program will need to be modified in order to properly communicate with the control program. The task diagram (shown in Attachment G) is used to plan out the structure of the code. The diagram shows each task along with its priority (with a higher number corresponding to a more important task) and operating period. Additionally, the information communicated between the tasks is shown. Each task is responsible for a specific function of the program and must be designed to run cooperatively, both with the other tasks, and any other programs that may be running. Each task can be split down further into a series of distinct operating states. Each state is responsible for doing one particular thing, and nothing else and each task can only be in one state at any given time. These states, along with transition requirements and transition actions, are arranged in a Finite State Machine for each task (also shown in Attachment G).

## Task 1: Mastermind

Priority: 0

Period: 1ms

Mastermind task is responsible for decision making within the code. It tells the other two tasks what to do and when to do them. The priority and period have been selected to ensure that this task runs in the background.

### State 0: Initialize

This state initializes needed drivers and performs set up tasks

### State 1: Hub

This is the default state for this task. Hub checks to see if any commands have been issued, then changes the state accordingly.

### State 2: Initial Position

This state moves the motor to its starting position. This can be done at any time.

### State 3: Set signal

This state sets the appropriate wave amplitude and frequency (if appropriate) for use by the motor.

### State 4: Set Mode

This state sets the operating mode (continuous, single or off) for the motor.

### State 5: Release Single Wave

This state commands the motor to release a single wave.

### State 6: Delay

This state causes the program to wait a period of time for waves to settle when changing modes

## Task 2: Motor

Priority: 1

Period: 10ms

This task is responsible for controlling all aspects of the motor.

### State 0: Initialize

This state sets up the motor drivers and will zero the motor.

### State 1: Hub

This is the off state for the motor. While in this state, the motor will move to a neutral position then wait for new input.

### State 2: Continuous

In this state the motor will create continuous waves. It will also check to see if it is running at the correct amplitude and frequency.

### State 3: Single wave

This state will set up the plunger for a single wave. After setup, it will return to hub

### State 4: Release the Single Wave

This state releases the single wave. After releasing the wave, it moves back to hub state.

### Task 3: Communications

Priority: 2

Period: 10ms

This task is responsible for receiving new information from the GUI program and alerting mastermind that a command has been received.

State 0: Initialize

This state initializes communication with the GUI

State 1: Gather Input

This state waits for a command. If it receives a command, it stores it.

State 2: wait for acknowledge

This state waits for mastermind to acknowledge that it has received the command before waiting for a new command.

## Analysis Results

Trace widths for the support board are dependent on the current, copper weight (thickness), and maximum allowable temperature rise. The current calculations were done by hand (see Attachment B.2.A) while a piece of commercial software (provided by Saturn PCB Design, Inc.) was used to determine the trace width according to IPC-2152. A maximum temperature rise of 20° C and a copper weight of 1 oz was used. The results are summarized below

**Table 7: Summary of trace widths**

<b>Location</b>	<b>Current (ma)</b>	<b>Minimum width (mils)</b>	<b>Width used (mils)</b>
24V line	3500	58.7	66
12V line	120	3.3	10
5v power line	2500	37.9	40
5V logic	20.8	2.9	10
3.3V logic	0.33	2.8	10

Similarly, this tool can be used to determine the maximum wire gauge used for external wires, such as the motor leads.

**Table 8: summary of wire gauges**

<b>Location</b>	<b>Current (ma)</b>	<b>Maximum gauge</b>	<b>Gauge used</b>
24V line	3500	23	22
5V power line	2500	25	22
5V logic	20.8	40	22

All of the commercial components are designed to operate under natural convection (or have internal fans). A heat transfer calculation was conducted to determine if the support board could operate under natural convection. The power dissipated by the 24V line and 5V line was determined to be 0.54W, this value was calculated using Saturn PCB's design tool. With a maximum temperature increase of 20°C the board could dissipate 3.2W. However, a fan will still be added to ensure that the ambient temperature does not raise significantly as the electronics are somewhat confined.

## Cost

Below is a table summarizing part costs for the electronics, including the accompanying mechanical assembly. Our sponsor has already provided us with several of the electronics parts outside of our budget. These parts are marked with an asterisk (\*) and the prices will not be listed in the table. For the complete BOM, see Attachment D.

**Table 9: cost summary of electronics**

<b>Part</b>	<b>Quantity</b>	<b>Total Price (\$)</b>
Sheet aluminum (24,12)	1	26.53
rivets	1 pkg	11.32
M2.5 screws	1 pkg	4.13
M2.5 nuts	1 pkg	2.22
M4 screws	1 pkg	4.85
M4 nuts	1 pkg	1.32
M3.5 screw	1 pkg	4.13
Raspberry pi *	1	0
Nema 23 motor *	1	0
Logic level converter *	1	0
Power supply *	1	0
St-m5045 *	1	0
Raspberry Pi screen	1	64.95
5V converter	1	8.95
12 V converter	1	7.49
0.1 uF capacitor	2	0.50
10 uF capacitor	2	0.42
Molex kk header	2	0.46
Raspberry PI shrouded header	1	0.95
Male headers	1	1.50
Female headers	1	1.50
1x2 terminal block	6	4.50
Spacers pack	1	1.79



22 gauge wire	2	10
Female crimps	1	5.95
1x4 female crimp housing	1	0.79
1x6 female crimp housing	1	0.79
80mm fan	1	6.08
Total Cost		\$ 171.12

This cost is subject to change. These prices are not necessarily the lowest and we have yet to select suppliers. Additionally, these prices do not include shipping costs.

### Selection Considerations

The current rating of the various connectors need to be taken into account. The male and female headers are only rated to 3A, so they can't be used for the 24V line. Terminal blocks will be used instead as these have a rating of 6A. Similarly, capacitors have an overload voltage, however, for our capacitors, this is 250V. Different types of capacitors perform slightly differently in different environments. A consulting CPE student advised using electrolytic capacitors for our board. These capacitors are polarized, so care needs to be taken while wiring. These capacitors will be tested (along with the rest of the circuit) and will be changed if needed. The lead spacing for the capacitors needs to be at least 2.5 mm. While any value larger than this will work, it needs to match the drawing so this needs to be finalized before the board is sent off to manufacture. Wiring for this project will be in 22 gauge, although some wires do not need to be this thick, one gauge is being used to reduce complexity.

### Testing

Before ordering the support board, a breadboard prototype will be constructed in order to ensure that the electronics are in working order. Additionally, the program will be calibrated in order to insure proper wave generation.

### Safety Considerations

The commercial power supply does not have an internal 120VAC connector, instead it requires individual leads to be attached to terminals. Although the wires are insulated, there is some exposed copper. All other wires are similarly attached; however, they are lower voltage. According to a safety manual put out by the United Auto Workers Union on electrical hazards, the 24V line can cause shocks strong enough to cause involuntary muscle contraction, while the 120VAC line can cause ventricular fibrillation (irregular heartbeats resulting in cardiac arrest). During operation, the electronics are not accessible by the end user and as such, do not pose

any risk. During maintenance, the power should be completely disconnected in order to prevent shocks. Additionally, hazard labels will be placed near or on the electronics package.

## Manufacture

Very little manufacturing is required for the electronics themselves. The support board will be made by a commercial manufacturer. Upon retrieval, components will be soldered into place. The mechanical assembly parts will be easy to manufacture and assemble in Cal Poly's machine shops. Once the assembly is assembled, the electronics will be attached and wired into place. Finally, the assembly will be attached to the frame.

## Maintenance

The electronics assembly is low maintenance. Compressed air should be used to clear dust from the electronics and fan at least twice a year. Beyond this, no other regular maintenance is needed. Electronic components may need to be replaced in case of failure

## Coastline and Water Treatment:

### Description

The coastline and water treatment play a critical role in the aesthetics and operation of this wave tank system, and they can be broken into two separate entities. The water treatment, as stated previously, will involve mixing a very minimal amount of tri-sodium citrate silver nanoparticles in the water of the wave tank. The coastline subassembly, consists of a rough surface made of 30-pound density RenShape foam, Flex Seal to coat the surface of the foam, and a coastline weight made of steel. The coastline will not be rigidly attached to the bottom of the tank, instead it will be heavy enough withstand any uplifting force from the impact of the waves on the coastline. An assembly model of the coastline can be seen in the following figure. The coastline shape was modeled to create a surging effect when the waves break, similar to a commonly surfed beach in Tahiti, French Polynesia known as Teahupoo. The surging helps to prevent any unwanted "backwash", or waves which are propagated backwards in the tank, through means of disrupting and dampening the reverse flow of water. It also creates a wave face size up to three times greater than the size of the wave before it crashes on the coastline.

### Analysis Results

The water treatment analysis follows a published recipe for synthesizing silver nanoparticles, and using a similar concentration for what is applied to antimicrobial sponges (Pradeep). This ensures that there will be enough of a concentration present to prevent unwanted bacteria from growing within the tank.

The coastline analysis consisted of calculating the buoyancy force resulting from the RenShape foam, and matching that force with a steel weight beneath it. The minimum weight requirement

was then multiplied by a factor of three, in order completely ensure the coastline wouldn't lift upwards as waves crash on it. The analysis can be seen in Attachment B.2.C

## Cost

The following table breaks down the cost of raw materials for both the coastline and water treatment. For the complete BOM, please see Attachment D.

**Table 10: Coastline and Water treatment cost**

Material	Quantity	Cost
RenShape Foam 30lb Density	1	\$110.43
Steel Weight	1	\$90
Silver Nanoparticles	1	\$50
Flex Seal	1	\$29.99
Total Cost		\$280

## Selection Considerations

The water treatment criteria for selection was based on choosing a treatment option that effectively kept the tank antimicrobial, cost effective, safe to handle, able to be disposed of, and ability to obtain replacements. Silver nanoparticles were selected as the treatment option for all of the above. Currently, according to the EPA, small concentrations, such as the concentration used in this tank, are safe for human exposure and can be dumped down a drain. A close second for water treatment selection was mineral oil, however the cost needed for one tank fill exceeded the price of the cost for silver nanoparticles by eight times.

The RenShape foam on the coastline surface was selected for its ease of machining and ability to be hand shaped, as well as it being able to resist water absorption.

## Safety Considerations

It will be noted here that the concentration of silver nanoparticles present in the water of the tank will not be toxic to human exposure, even if small amounts of the water are ingested. At this concentration, it can also be dumped down the drain. However, the EPA acknowledges that there is a lack of studies on the subject so this may change in the future.

## Maintenance

Maintenance of the water treatment should be unnecessary for its designed life. However, if at any time the tank needs to be drained, a proper amount of silver nanoparticles should be added to the water once it's refilled. The water level should be filled to the indicated mark on the side of the wave tank. The amount of silver nanoparticles that will need to be added is 63ml of .02mg/ml silver nanoparticle solution.

## Tank Body:

### Description

We will need to build our own large tank that is able to allow for the waves to fully form, lose minimum water and be durable throughout the long demonstration hours and any possible creative user interface from the younger guests. The main criteria that this tank is being held against is that it: allows a good enough view of the waves, can hold sufficient water, does not leak, and is relatively cheap.

The internal dimensions of the tank are 18 feet long, 2 feet tall and 6 inches deep. The overall demonstration cannot be longer than 20 feet, as one of the size restrictions given from the museum, thus 18 feet was decided upon since it will most of the allocated space but is flexible if that number were to change. Based off of calculations of acrylic thickness due to the water level, we knew that we wanted to use ½" thick acrylic, thus the maximum water height we allowed ourselves is 17". The calculation was made assuming mostly static water, and since our system will be dynamic and the water height will be changing depending on the wave, we decided that having a nominal water level of about 9 inches, will be safe and ensure a longer life of our tank. Since the visitors will be interested in the wave motion in only one dimension, down the length of the tank, we only need to create a one dimensional flow. This is why the tank will not be that deep. We want to minimize water weight, fluid movement dispersion, but also create a stable tank, one that would not be easily tipped over.

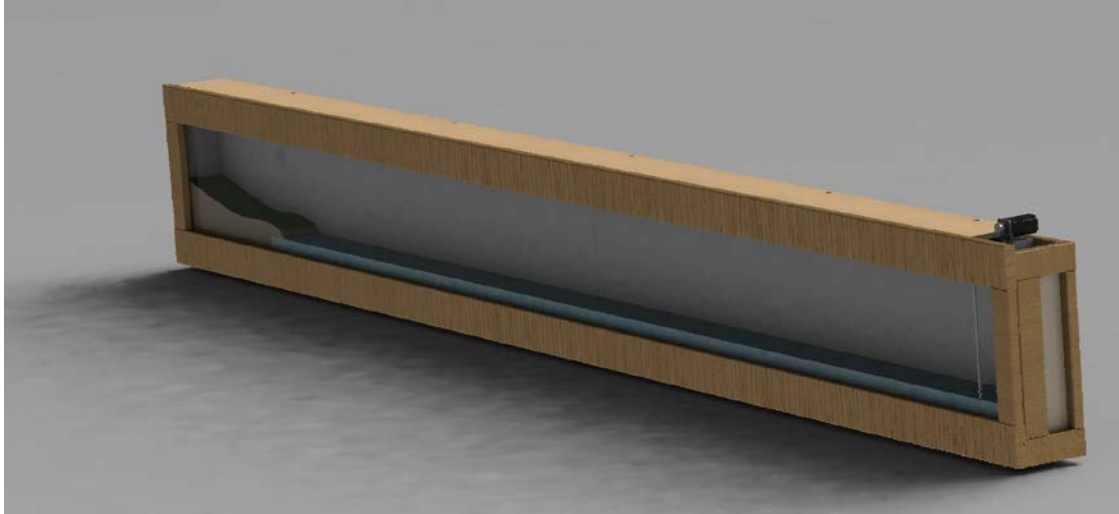

Figure 23. Full Wave Tank Assembly

We inherited a large sheet of cast acrylic from the Allan Hancock College, and since cast acrylic is one of the main materials used in aquarium construction, we decided that we would use acrylic, so as to help keep our costs down. The main challenge is then how to create a long strong acrylic sheet and how to seal it. There are solvents that glue/weld any two pieces of acrylic together. It creates an almost seamless joint and is very strong since it melts each part into the other. As for sealing, the acrylic window will be bolted against a hard clean surface with silicon caulk between the two surfaces.

To keep costs down, the rest of the tank will be built out of hardwood plywood and lumber that is easily accessible. The outside of the tank will look similar, but with a large acrylic window in the front.

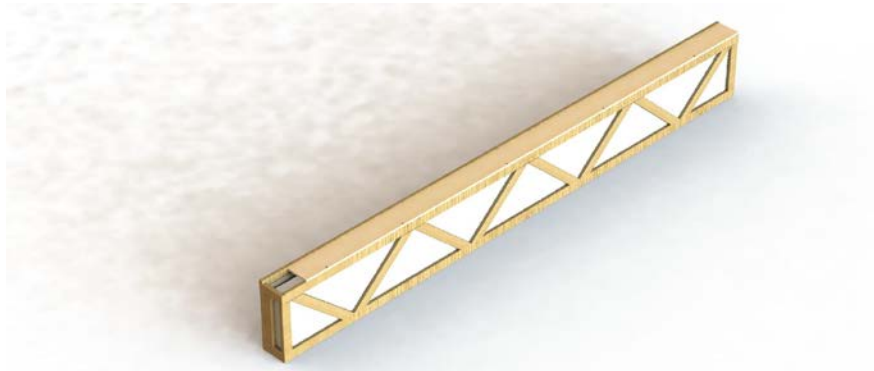

Figure 24. Tank Assembly

The wood will be sealed through a multi-step system. Large sheets of thin PVC will cover the wood to provide large and consistent scale sealing of the wood surface. We were concerned that if we used only a wood epoxy sealer, that we could not fully ensure a long term leak proof system since the thickness of the epoxy seal might not be consistent. Any small leak would go

undetected and slowly rot the structure. This is a large concern. Since we are unable to buy sheets of PVC the size that we need to cover we will need to glue them in a similar fashion that we will combine the acrylic sheets, just with a different type of solvent. Corner joints be fixed together with fiberglass and resin. The fiberglass will help strengthen the structure and seal the corners. This layer of PVC and Fiberglass will be on the inside of the Tank. Between the PVC layer and the wood, there will be painted flex seal at underneath all of the joints of the PVC. This will act as a gasket layer that will stop any water that makes it past the resin and fiberglass. And since it is not reasonable to coat all the structural beams with PVC, we will apply a coat of Pond Seal to cover any piece of wood open to the inside of the tank.

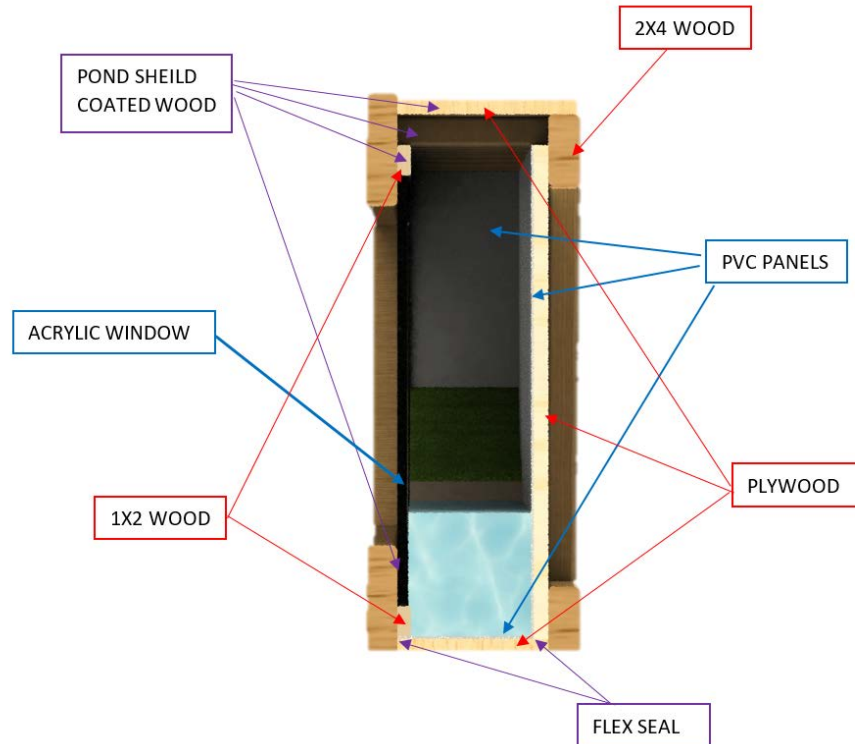

Figure 25. Cross Sectional View of Wave Tank Assembly

The tank will be accessed from the top by the quick removal of the top support beams, the beams where it will be probable to be the most accessed, and most removed points will not be screwed down but rather pinned in place. These cross beams will provide the layer to that hold up the roof of the tank. Since we do not want our water supply to slowly deplete due to evaporation or to become dirty from its exposure to the rest of the museum. A hard seal does not need to be made at this side of the tank, since the water level will not reach that height, and we are really only trying to mitigate long term evaporation and contamination. The underside of the roof will be coated in pond shield to protect the wood from the moisture in the tank. Since there will be ceiling panels, we will provide internal light so that the display is easy to see. We have chosen to use LED rope as a lighting source in order to add even lighting and separate the lighting circuit.

## Analysis Results

Based on the water tank dimensions, 15' x 10" x 6" for 15' instead of 18' since the coastline will take up 3 feet of length, and the accepted water density of 1.93 [slg/ft<sup>3</sup>], the water volume that our tank will need to hold is 46 gallons, as calculated in Attachment B.2.B. This is right about that amount that a bathtub holds. Our water will weigh 366 pounds which will lead to a load of 0.36 psi across the bottom of the tank floor. This pressure is insignificant and is not a concern since the weakest wood has a perpendicular compressive strength of 300 psi. Even when the level of the water rises due to the wave, the water level will not rise more than 1.5 x the nominal and thus even at 15 in of water depth, the bottom of the tank will see a 0.54 psi load, still very small. The max pressure of the wall will be at the base of the wall which matches the bottom pressure. Even when there is water movement, there is low water shear, so the dynamic loads of the water will be greatest at the end of the tank but not on the sides of the tank, specifically the acrylic window. We do not know the velocities of the waves that we will be making, since that data will be gathered from our experiments but we can safely assume that the dynamic loads will be below that which the wood panels can handle.

The thickness of the acrylic was based off of the thickness of the stock we were already given, and then this thickness was verified to make sure it could handle the loads that the water would apply. The nominal thickness of our stock is 0.47". With this thickness we should not reach a water height greater than 17". Acrylic has a tensile strength of 10,000 psi, but since it is seeing a lot of repetitive loading, it is safer to build as if it had a 750 psi tensile strength. The calculations for the acrylic thickness can be seen in Attachment B.2.B. With the calculation of the acrylic thickness needed, the CYRO calculator stated that we would need 0.391 in. thick acrylic. Assuming that the calculator does not have a built in factor of safety, even though there is the simple assumed weakness of acrylic, the factor of safety that our system has is about 1.2. Knowing that the calculator did assume a tensile strength of acrylic about 8% that of its original stated strength, this 1.2 factor of safety should be plenty

## Cost

The following table summarizes the cost of the tank. A more complete BOM is available in Attachment D.

**Table 11: Tank Cost Summary**

<b>Part</b>	<b>Quantity</b>	<b>Overall Cost</b>
1/2" x 24" x 96" acrylic	1	204
1/2" x 24" x 24" acrylic	1	53
Pack of plastic syringe	1	9.68
Eco-Bond Caluk	2	25.5
1/2" hardwood plywood	4	99.92
1/4" x 1" 316 SS wood screw	1	10.44
1/4" 316 SS washer	1	7.29
1/4" Buna_N o-ring	1	2.29
1/8" x 48 x 96" PVC sheet	3	399
steel corner bracket	30	17.4
Weld-On Heavy Duty PVC Cement	1	7.99
#9 x 5/8" wood screws	2	11.66
2" x 4" x 16' wood	6	41.88
1" x 2" x 8' wood	5	12.9
2" x 6" x 12' wood	3	23.55
30' soft white rope lights	1	31.95
6.6' soft white rope light	1	16.95
6 ft. extension cord	1	6.26
Black Pond Shield, 1.5 Quart	1	75.95
Gorilla Wood Glue	4	15.48
1 sq. yard Fiberglass Cloth	2	19.96
Fiberglass Resin	1	75
	<b>Total</b>	<b>1321</b>

Since we will be wanting to create water tight areas through the use of acrylic and PVC sheet, we will be buying the largest stock available so as to minimize joint locations where water can seep through. This raises the issue of shipping cost, since shipping anything that large would cost about just as much as buying that stock. We have looked at companies that could supply both of these materials that are relatively close by. Our team will dedicate a day to rent or borrow a large truck, and drive to the supplier and pick up the material ourselves. We hope to use one of the Universities' vehicles instead of renting a truck, so that would lower the shipping cost to only the cost of gasoline. Our preferred supplier is about 180 miles south of San Luis Obispo, and U Haul trucks on average get 10 mpg, and assuming atrocious gas pricing, that trip



would cost us no more than \$144. This beats the estimated cost of shipping of \$120 for each material.

We will be able to utilize the tools and machines in the Universities machine shops, so we will not need to buy tools specific to the making of this tank or send parts out to be done by a third party. Manufacturing costs should only include the costs for added hardware, such as extra screws and moderate bonding agents such as wood glue.

## Selection Considerations

Since we wanted to use wood as the majority of the tank body, as it is inexpensive and easy to obtain. To seal the wood, we were concerned that if we only used an epoxy sealant that there was a greater chance that if the epoxy was not applied properly it would allow for water to pass through and rot the structure. To get around this problem, PVC sheets will be used to cover the majority of the wood's contact surfaces with the water. Then we will use epoxy sealant to cover the remaining parts of wood that is not in direct contact with the water.

PVC is the cheapest plastic rigid material, and is known to be water resistant. Using a fabric like plastic coating, like a grand plastic bag, would not make the inside of the tank look all that great and might interfere with the waves as the fabric would be pulled out into the stream and pushed forwards causing wrinkles and protrusions into the stream.

## Safety Considerations

The tank does hold the possibility of being hazardous in that over long exposure the acrylic window cracks or the wood structure rots and the tank floor bursts. Acrylic is a nice material in that when it does fracture, it does not break into sharp shards and that it does not shatter unless it experiences direct impact. Assuming that visitors will not smash hard objects into the window, the window will slowly crack, similarly to how a car windshield slowly cracks. And then when a crack does occur, it will be quickly noticeable since water will start leaking. At this point the tank will be easily carted outdoors and drained. For the concern of the wood slowly rotting and dropping the tank floor, the water level of tank will be visually dropping and will be a clear flag to check the bottom of the tank and to drain it. In both instances, leaking as such will not cause catastrophic harm to the museum or to the visitors.



Figure 26. How acrylic fractures

[http://windborneinpugetsound.blogspot.com/2009\\_11\\_01\\_archive.html](http://windborneinpugetsound.blogspot.com/2009_11_01_archive.html)

The tank will hold less than 50 gallons of water, so if it were to somehow burst it will be a quick flooding and will have a small area of harm.

## Manufacturing and Maintenance

Building this large tank structure correctly and squarely will be a good challenge. The best way to build it is to do it in large pieces. Listed below are our planned states to build this structure.

**A.** The wood back made of plywood with the 2x4's, the two wood side walls, and the bottom floor, and the bottom length cross piece, all done separately.



Figure 27. Tank assembly reference 1

- B.** Attach these sides together with the corner metal brackets, and adjust accordingly to make square.
- C.** Cut and fit the PVC panels, and before gluing or epoxying the panels on, apply flex seal in the cracks and in the areas where it is now known where the PVC sheets will join.
- D.** Coat any open surface of the 1x2" and the acrylic contact surface of the 2x6".
- E.** Once both the shield and the flex seal are thoroughly dry, scratch up the whole underside of the PVC and glue first the floor PVC panels, the back panels, and then the side panels. Each section of panels should be done one at a time using c-clamps or other pressure applying methods to ensure a relatively consistent level of the PVC planes, and fully dried and cured before moving onto the next panel section.

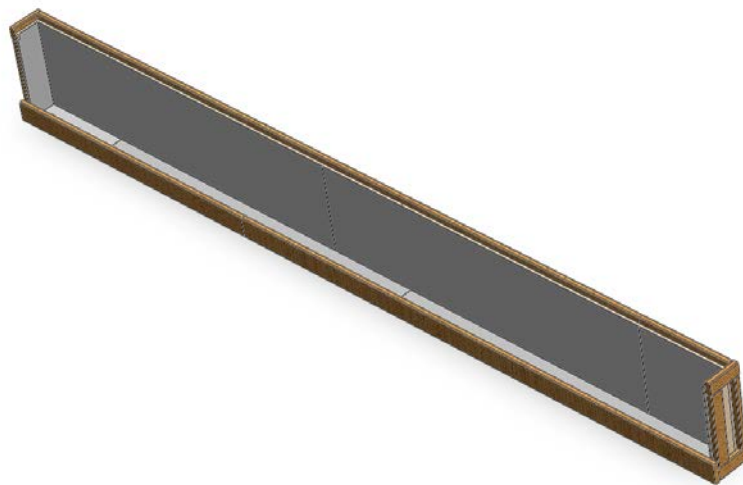

Figure 28. Tank assembly reference 2

**F.** Add a small and thin layer of fiberglass and resin to the cracks, and apply a small amount of PVC solvent at the planar joints of the PVC panels. Also glue in place the PVC coupler for the drain port

**G.** Cut the large acrylic sheets and make the top length beam. Tip the tank such that the acrylic window would be parallel and closest to the ground. With caution, roughly line up the length beam where it should be placed, but then place the acrylic in so as to correct the position of the cross beam so as to give the acrylic an extra ¼” of clearance. Mark this position, remove the acrylic sheet and rigidly attach the length beam in the correct spot.

**H.** Cut the ceiling cross beams and drill the corresponding dowel holes into the tank top. Cut the dowel rods and press and glue them into the tank dowel holes.

**I.** Cut out the ceiling panels and drill the corresponding dowel holes on the topside of the tank body. Cut out the dowel rods and press and glue them into those tank body holes.

**J.** Coat the internal exposed faces of wood with Pond Shield. This includes the top acrylic contact wood parts, along with the ceiling cross beams and the underside of the ceiling panels.

**K.** Cautiously drill the necessary holes in the acrylic by stepping up in drill size and by placing tape over where the hole is about to be drilled. This is still with the individual sheets of acrylic.

**L.** When the tank is still tipped such that the window side is facing downward, apply caulk onto the now dry pond shield surface where the acrylic will seal up against. Quickly place the corresponding acrylic sheet there and screw into place. Do this the whole length of the tank until the full window is in place.

**M.** For temporary sealing of the windows, caulk the joints, when officially setting up the demonstration, apply a medium amount of acrylic glue to the side faces, when inserting the adjacent panels in the step before

For most instances in which the tank will need maintenance work, the tank will need to be drained. A drain hole will be implemented in the bottom of the tank, beneath the coastline. The hole will have a wall to hose pipe fitting, such that a hose can be connected to the bottom of the tank and drained once the hose is unplugged. The hole will be plugged with a simple rubber stopper. To safely drain the tank, the tank should be carted outside, attached to a hose, and the plug taken out of the hole. The cart does not need to go outside, but it would be safer to do so.

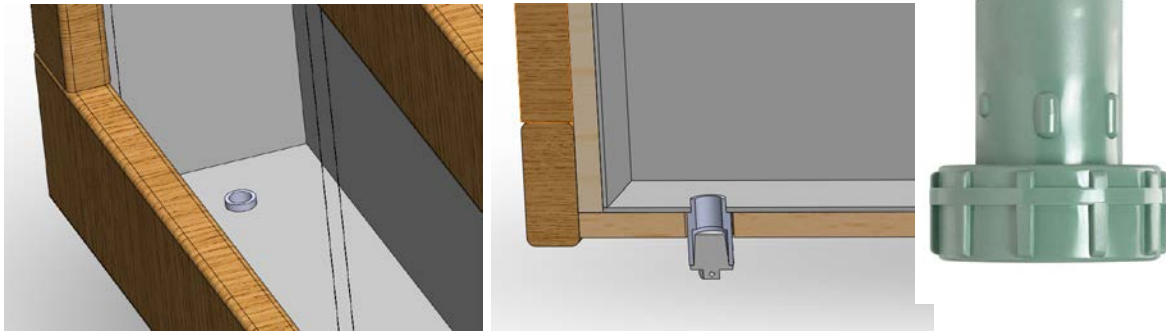

Figure 29. Drain below the coastline

<http://www.homedepot.com/p/1-in-or-3-4-in-PVC-Manifold-Slip-Swivel-Adapter-57202/202206765>

Our aim is to make the tank as easily maintainable as possible. The first method of doing so, is to design such that it is rare for maintenance to be needed. This is important in respect with the structure of the tank. This is why it is very important that the wood of our structure does not see any rotting, since if that were the case, it might be very hard to replace the rotting part. The wood structure will be screwed and lightly glued together, so that in the case that a wood member does need to be replaced, that it is relatively easy to do so. If the rotting is caught early on in the stage, then the tank should be drained, the wood dried, and the leaking source identified and fixed.

## Tank Support Structure:

### Description

This part of the project will not be completed by team seismic surge. With the exception of parts interfacing with the electronics assembly, all dimensions and materials are solely a recommendation. Team Seismic Surge will not be selecting steel, purchasing, or manufacturing the support structure. The tank support structure consists of a steel alloy support frame that is connected to 10 heavy duty swivel casters. The frame also contains an arm rest made of wood, that has a groove cut out for where the touch screen control pad is to be mounted. An assembly view can be seen in Figure 30. The steel frame consists of standard size, square steel alloy bars, and L brackets. Every joint connection seen in the tank support structure assembly drawing is to be welded together. The rectangular bars at the base of each leg connecting to the swivel casters are also made of steel alloy, and contain holes to which the casters will be bolted to. This support structure design also incorporates the ability for it to lock to another fixture positioned on a wall, to ensure that the full assembly does not move. This support structure was designed to have larger steel support pieces on the bottom of the structure than the top, in order to make the structure more bottom heavy, and resistant to tipping.



Figure 30. Support Structure Assembly

## Analysis Results

Analysis performed for the support structure neglected the calculation for loading on the joints, as rule of thumb being that if it's steel and it can be welded, it will support loads much greater than required of this system. However, a frame and assembly tip over analysis was conducted. The calculations are detailed in Attachment B.2.D. It was found that in order for the frame to tip over, a horizontal force of 2480 N would have to be applied at the very top of the wave tank itself. To put this number in perspective, it would take two Usain Bolts running at full speed (27mph) to impact the very top of the top of the wave tank. Given that this will most likely not occur, this tank support structure design should be satisfactory enough for the safety requirements specified prior.

## Cost

As Team Seismic Surge is not selecting or ordering material, costs for this part of the project are not included in the overall BOM.

## Selection Considerations

The materials chosen for the tank support structure were selected due to their ease of accessibility and manufacturing. Steel was selected for the base material for the structure since it has a very high strength and also weighs a lot. It's also one of the easiest materials to weld. A wooden arm rest was selected for aesthetic looks and also cost. The swivel casters were chosen so that the cart can be easily wheeled around. The casters can each support a load of 1600lbs, multiply that by ten and the total support capability equates to 16000lbs. The whole tank and support structure itself only weighs 1200 lbs, even when it's filled.

## Safety Considerations

Safety considerations were of the utmost importance when designing this structure. It was designed so that it would be incredibly hard to tip the tank over. Additionally, when moving this

tank, it should not be moved at a speed greater than that of 3 mph and should have 4 people moving it at one time, with each person positioned at each corner.

## Manufacturing and Maintenance

For manufacturing of the tank structure. The steel members will need to be welded together. Certain pieces will need to be cut as specified in the support structure drawings section listed in Attachment H. Besides welding, the swivel caster will need to be bolted to the support structure, and the wood armrest will need to be cut out as specified so that it can incorporate the control touch screen in the arm rest. It will be noted here that this engineering team, Seismic Surge, will not manufacture the structure itself, and is passing on this support structure design as a recommendation for a professional fabricator to weld.

# Chapter 5: Implementation and testing of the Wave Tank

Once we had the approval to go forward with our design we began manufacture and testing. As with any build, we ran into problems and had to modify our design. Below is a summary of the changes we made and our recommendations to the Museum and to Allan Hancock with further installation of the wave tank.

## Mechanism

### Change in Design

After preliminary testing of the sliding capabilities of our mechanism, it was quickly realized that our design from our CDR would not be suitable. The main problem with the mechanisms sliding abilities was that it would routinely get jammed in the guide rail slot. After trial and error for figuring out the cause of the jam, it was found to be caused by a couple flaws in the design. One issue was that the running and sliding tolerances weren't large enough to allow for smooth sliding. It was found that the mechanism vibrated slightly caused by the rubbing of acrylic to the metal and it was enough for the corners of the metal guide rails to get jammed and stuck in the corners of the acrylic wedge. Tolerances were improved for this design because of this. The second reason for the jamming was a result of the location of where the belt was rigidly connected to the wedge. Originally we had designed the belt to be attached to the back of the wedge. Once tension was applied to the belt to move the wedge up and down, a moment was also applied at the location of the slot for the guide rail. This moment caused the wedge to rock

forward and backward ever so slightly due to the tolerances of the guide rail slot. This motion was enough for the wedge to jam up in the slot. To counter this problem, we changed the location of where the belt was rigidly attached to be directly in line and in the same horizontal plane as the guide rails. This eliminated the rocking motion in the guide rails and enabled the wedge to slide freely.

## Recommendations

There has been some ideas that instead of using a stepper motor to drive on a belt and sprocket system, that it would be best to use pneumatics or a motor with an encoder. Though both of these ideas are viable, we do not think that they ultimately solve the problems that they set out to solve.

There is concern with the excessive wear on the belt and that parts of the mechanism will rust over time due to its exposure to a humid environment. We highly recommend that with whatever mechanism is used in the end, that it be painted to minimize corrosion. Though a pneumatic system would definitely be strong enough, unless it was a very bulky system a rail system would still be needed. There is also the additional leak check of the airlines, and there would be concern of corrosion on the piston sealing surfaces.

Another large issue that we ran into with our mechanism was the drifting of the wedge; meaning the wedge would go further in one direction than it would in the other direction. Having a feedback loop would definitely help with this, as our system would constantly correct its actions so that it no longer drifts. The drifting is partially due to the code, but also of the belt system. As the belt ages, it will begin to slip. So while the motor thought that it had moved, in reality it had not. A closed loop system could be implemented to keep track of the wedges position and make sure that it does not ram into other components.

If the current method of a mechanism is desired then there will need to be some new revisions. The motor is not rigidly attached to the tank, when it is turned on there is visible vibration, which will wear and tear over time. We only ran the system about an equivalent length of two days, and there were already signs of wear. So a more rigid motor mount will need to be made. When we found that we needed to make a quick idler to increase belt tension and to redirect the belt to avoid a sharp corner, we made a quick roller that added enough tension to minimize the slipping of the belt. This is still adding wear to the belt, along with other sharp edges. So when the motor mount is redesigned, there should be an actually designed idler. This would drastically reduce belt wear and slippage over time would not be a concern.



# Electronics and Control System

## Change in Design

Ultimately, the raspberry pi proved to be unable to accurately run the control software. During testing, the Raspberry pi was tasked with generating a square wave. The wave's frequency had a tolerance of  $\pm 20\text{Hz}$  and had occasional spikes and dips exceeding  $70\text{Hz}$ , this caused noticeable stutters and other undesirable behavior in the motor. Because of this, a Pololu A star Micro microcontroller was used to run the control software. This also required changing the language to Arduino from micropython. Making this change allowed us to produce a square wave with a tolerance of  $\pm 0.1\text{Hz}$ . The support board was changed to accommodate the new microcontroller. These changes are minor and can be seen in the new schematic and board drawing. The code was also drastically simplified and runs off of one task and state. Finally, this change means the two programs communicate with each other over a physical serial connection instead of using additional software.

At the request of the Santa Maria Discovery Museum, the electronics casing was changed to an enclosed box instead of an open enclosure. Drawings have been included in Attachment H.

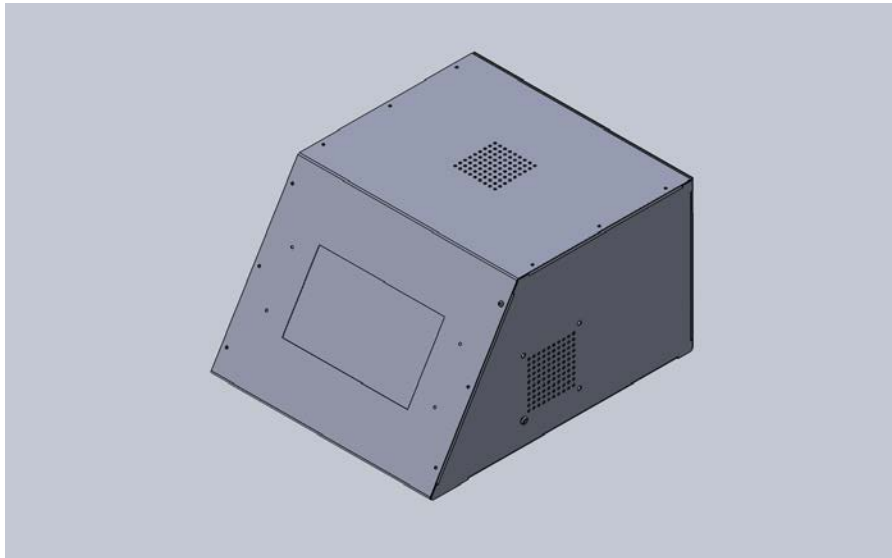

Figure 31: revised electronics enclosure

While we initially planned for the user to be able to input arbitrary amplitudes and frequencies, this has changed somewhat. The values must be whole numbers and are limited to 1, 2 and 3 inches or hertz.

## Recommendations

The motor driver selected for this project has given us significant problems. Our sponsor initially provided us with a Sainsmart St-m5045 stepper motor driver. During initial motor testing, this

driver failed and was replaced. This replacement failed shortly before expo. Because of this, it is our recommendation that a different motor driver is chosen. There are four main options moving forward.

First, another St-m5045 can be selected. This solution requires no modification to the existing program or hardware, however due to previous part failures, we do not recommend this option

Second, an X-Nucleo-IHM03A1 motor shield can be used.



Figure 32: Nucleo motor shield  
Digikey

This will require a wire modification of the existing circuit board. While this is easily accomplished, there isn't an easy way to secure the shield, meaning there is a risk of electrical shorts. Additionally, this would require a not insignificant change to the program

Third, the existing support board could be redesigned to accommodate a stepper motor IC, such as the STMicroelectronics powerSTEP01 used in the nucleo board above. This would require a redesign and re ordering of the support board in addition to modifying the code.



Figure 33: PowerSTEP01  
STmicroelectronics

Fourth, a usb controlled stepper motor driver, such as the Trinamic Motion Control GmbH TMC2130 can be used. This would allow the Raspberry Pi to directly control the motor, and would eliminate the need for a microcontroller. However a support board would still be needed. Using this option would require porting the program to either C++ or python to run on the Raspberry pi. Although the program would need to be completely re-written, it can be simplified as well. Additionally, the electronics housing baseplate would need to be modified to mount this board.



Figure 34: Trinamic Controller  
digikey

Due to manufacturing delays, part failure, electrical and software redesigns, the driver program could not be adequately debugged and tested.

The control software currently produces poor single waves. Currently, single waves are created by moving the motor through a cosine wave and stopping at the peaks. In order to improve performance, a different path needs to be designed. This path should start at a peak and very rapidly drop into the water, before being reset.

While the initial goal was to allow the user to select wave frequencies and amplitudes, the control program shows poor performance for waves larger than two inches and frequencies larger than 1 hz. There was no noticeable drift from the mechanism, the code currently causes the motor to drift downwards. While there is error correction code that appears to correct the problem, the overall effectiveness of the correction code is not known. We believe that these problems are structural to the code and another revision may be required.

Because the primary goal was to fix major errors in the code, program hasn't been extensively debugged and there may be more errors that we have not discovered. Additionally, the program is currently in a partially finished debugging setup, not a final polished product. Finally, the program needs to undergo testing once it is properly working. The testing procedures can be found in the Testing Verification plan Attachment J

## Water Treatment

### Change in Design

As mentioned previously, an aqueous antibacterial silver nanoparticle solution was going to be incorporated in our final design. However, after testing the silver nanoparticle solution over the course of several months, it was found it wasn't as effective as it was supposed to be. Over time, the silver nanoparticles lost their inherent antibacterial characteristics and mildew and or bacteria grew in the water. After deeper investigation, it was found the silver nanoparticles lose their antimicrobial capabilities when exposed to light in the long term. Although this problem exists, the silver nanoparticle solution could still be implemented with the drawback being the concentration of them would have to be replenished repeatedly. In the long run, it may prove be as expensive if not more to go with this water treatment option in the final design than other permanent alternatives.

### Recommendations

An alternative water treatment option, instead of using silver nanoparticles, could be to use mineral oil. Mineral oil solves the antibacterial dilemma and it's also a permanent solution. In

addition to this, they may also be much cheaper in the long run since it doesn't have to be replaced. Mineral oil can also be readily mixed with dyes and come to be odorless and colorless, whereas silver nanoparticle solutions appear to be a murky grey color.

## Tank Structure

### Change in Design

Due to the nature of the materials used; the wood planks from Home Depot, some slight adjustments needed to be made to the dimensions to account for the warped wood. there is about an extra inch in the width between the top and the bottom. The main crooked piece, was the front top cross beam. Due to the wood, and the expanse that it had to hold itself up, there is are sizable discrepancies in width as one goes along the length of the tank. Luckily most of our other materials are flexible, or we made short enough segments, to hide the crookedness. This should not interfere with how the tank will be finally implemented in the museum.

The largest change to the design was in the change of top sealing method. Initially it was expected that Silicon Caulk would be used to seal the cracks on the inside of the tank. This proved to be a very un-reliable material choice, since the silicon did not adhere well to the PVC panelling, and thus it would easily rub off. At one point we ripped up all the caulk and started anew, by using clear flex seal. We did test out other materials, and flex seal adhered the best to the PVC. This material is also nice in that it is much less viscous, so it easily flows into all the cracks, as opposed to the caulk that just sat on top and would not always seal.

### Recommendations

Though it was attempted to make the tank as rigid as possible, to maintain some sense of small size and aesthetics, the tank is a bit wobbly. It was found that as we routinely rotated the tank either onto its face or back for ease of sealant access, there would sometimes be new tears in the sealant on the bottom. Once the tank is in its final location and locked to the back wall this will not be an issue. But it should be kept in mind to move it only when necessary. There will probably be new leaks in the tank due to the move from our campus to the museum. Methods for leak testing and resealing can be found in our Attachment J, *Verification Test Plan*.

Further additions to the tank structure will be based off of the location and its surroundings. We did not apply a method of locking the tank down since we did not know the type of table it would be sitting on, and what wall locking system would best fit their needs. Since at this time the museum is going through new revisions in the area where our tank will be we felt that it would save effort and confusion to leave such matters to them.

We implemented a basic roofing, knowing that a new one would probably be built by the museum to better fit aesthetically and to bolt onto whatever they desire. This is the same with

where the drain valve is. Right now there is a PVC Ball Valve that is used to drain the tank at a reasonable rate. We looked into smaller valves, but they took way too long to drain; and in the event of a leak, it is desirable to drain as quickly as possible. Depending on the table that the tank will sit on, this valve can be hidden from prying children's hands. Even if the valve was locked but still accessible, there would be a large concern of bending the tubing or the sealant around the tubing. That is why we highly advise that the whole section is locked up inside something whether it be the table, a box or a box disguised as a structural column.

As engineering students we pride ourselves in creating functional but not necessarily aesthetically pleasing solutions. The tank is still in its raw form, but will need future touch ups to match the other exhibits in the museum and to ensure that there are remaining safety hazards.

## Coastline and Support Structure

### Change in Design

We were unable to make the coastline in time, and thus the team down at Allan Hancock was kind enough to fully build the coastline skeleton. Instead of high density foam, a PVC structure was built, this was because there was a fear that the foam would be positively buoyant and would make it a lot harder to keep the coastline submerged. The dimensions also changed; as further research was done we found that it is a lot better to use a longer but with a lower slope coastline. This about doubled the length of our coast line from 4 ft to 8ft; which is roughly half the length of the tank.

It was stated that once the tank and the coastline return back to Santa Maria, that there will be art students who will add foam to the top to make the surface look more like land to and extentuate the crashing of the waves.

From the outset, we knew that we were not responsible for the creation of the tank support table. We were hoping that we could draw up designs and hand them off to another group within our university, but that did not work out. We are currently looking at commercially made tables, since this will probably be time efficient, quality made, and still be within the budget.

The main considerations to be made about the table are as follows:

- Sturdy and can handle the weight
- minimizes the the possibility to tip during the moving of the tank
- Allows the tank to be rolled to different locations
- Not too high up to minimize that tipping and so that kids will be able to easily see it
- There should be table support for about 75% of the tank length

With these in mind, a possible solution would be to rigidly hitch three or four of the tables shown below.



## Chapter 6: Conclusion

This report is a compilation of our preliminary design, critical detailed design, testing, and manufacturing summary of our wave tank project. It also includes recommendations for further actions to take in order to fully implement the system safely in the Santa Maria Children's Museum. In order to reach this point in our project, we used brainstorming techniques and preliminary testing to gain an understanding of how to effectively create waves. Then, we used this information to first come up with a conceptual then derive the detailed design of our entire system. Once building and further testing of detailed design began, subsequent design changes were made to all aspects of our initial detailed design. Concluding the work that's been completed thus far, we have constructed a tank that can generate continuous waves, however there are still some issues with the system. Further investigation is recommended for implementing the mechatronics system with a graphical user interface in order to make the system functional for the desired user, ideally a child. Additionally, some work is recommended for the completion of the coastline and functionality of single input waves. We have also recommended a couple of possible design changes to the system and they are mentioned in the previous chapter. The cost of our project came in at \$2,338.28. Although this is several hundred dollars more than we initially expected, it is still under our given budget of \$2161.72. Overall, we have constructed a wave tank that is functional but still requires further investigation before implementing it in the Santa Maria Children's Museum.

# Attachment A: Design Selection Documents

## A.1 QFD

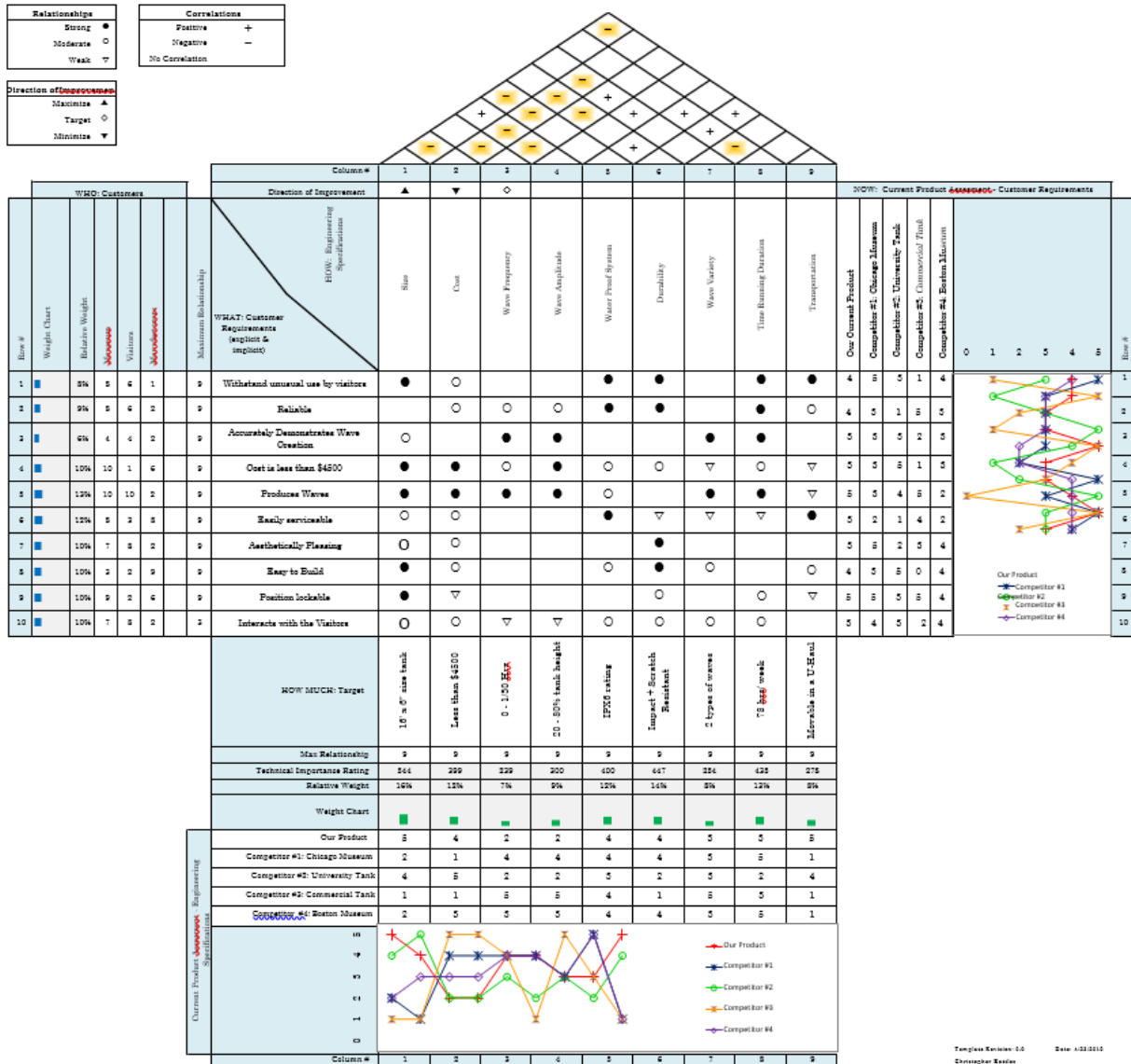

Template Revision: 0.0 Date: 1/23/2010  
Designer: Kester



## A.2 Preliminary Design Summaries

### Cam Mechanism

This mechanism rotates a cam on the surface of the water to create waves

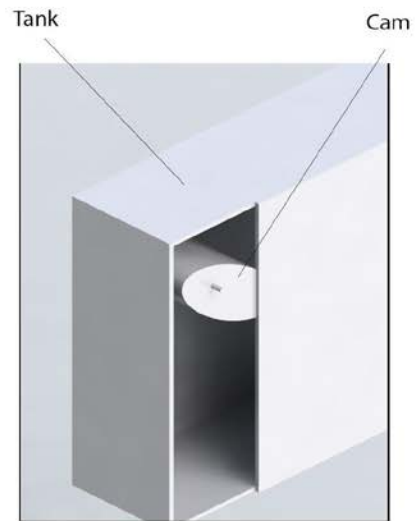

#### Pros

Simple

Rotary motion

#### Cons

Complex geometry

Small water displacement

## Piston Mechanism

This mechanism moves a plate back and forth horizontally to displace water and create a wave



### Pros

Moves entire water column  
good wave generation



### Cons

Larger force requirement  
more difficult to waterproof

## Plunger Mechanism

This mechanism moves an angled plate vertically in the water to create a wave

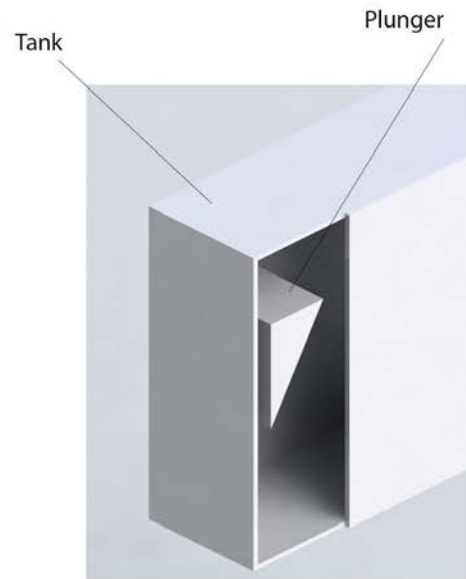
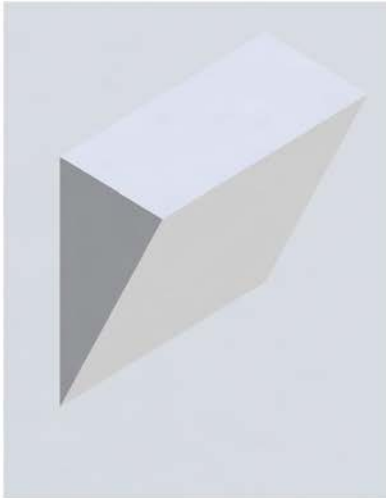

### Pros

Best wave generation  
(especially single waves)

easy to waterproof

### Cons

standing wave issues

lacks shallow water wave motion

#### A.4 Pictures of Prototypes and Cam Testing



These are the cam prototypes that we built to test out in our second tank test. We wanted to test how the shape of the cam would affect its wave making capabilities. The Cam that worked the best, though, was successful because it was large enough to affect the whole top of the water column. But in the end none of the cams made as great of a wave as the reverse plunger did.

#### A.4 Design Matrix

Tank Wave Mechanism Design Matrix									
Specifications	Weight	Cam		Plunger		Drop Tank		Piston	
		initial	weighted	initial	weighted	initial	weighted	initial	weighted
Child Enthusiasm	7.5	6.5	48.75	7	52.5	4	30	7	52.5
Safety	4	8	32	8	32	6	24	7.5	30
quick charge[max 30sec.]	6	10	60	9	54	4	24	7.8	46.8
Force needed	3.5	9	31.5	9	31.5	5	17.5	5	17.5
complexity [# moving parts]	7	10	70	9	63	6	42	8.5	59.5
ease of waterprofing	7	7	49	9	63	5	35	5	35
durability	8.5	7	59.5	8.5	72.25	6	51	7	59.5
compactness	2	9	18	7	14	4	8	6.8	13.6
cost	5	9	45	7	35	3	15	5	25
Engineering pride	3.5	5	17.5	8.5	29.75	10	35	7	24.5
manufactorability	6	9	54	8	48	4	24	6.5	39
size wave	3.5	5	17.5	8	28	3	10.5	6.5	22.75
Total:			502.75		523		316		425.65

Table 6. Design matrix of the last making waves. We implemented basic accurate number values for the size of

remaining main design ideas for the method of mechanism prototyping and testing to give more wave.

# Attachment B: Analyses and Specification

## B.1 Vendor Supporting Data Sheets

128	25600	ON	ON	OFF	OFF
256	51200	ON	OFF	OFF	OFF
5	1000	OFF	ON	ON	ON
10	2000	OFF	OFF	ON	ON
25	5000	OFF	ON	OFF	ON
50	10000	OFF	OFF	OFF	ON
125	25000	OFF	ON	ON	OFF
250	50000	OFF	OFF	ON	OFF

### 2、 Current choice:

Peak current	Reference current	SW1	SW2	SW3
1.0A	0.71A	ON	ON	ON
1.5A	1.07A	OFF	ON	ON
2.0A	1.43A	ON	OFF	ON
2.5A	1.79A	OFF	OFF	ON
3.0A	2.14A	ON	ON	OFF
3.5A	2.50A	OFF	ON	OFF
4.0A	2.86A	ON	OFF	OFF
4.5A	3.21A	OFF	OFF	OFF

### 3、 Full current or half current choice:

SW4:OFF=Half current ; ON=Full current;

### 4、 Pulse choice:

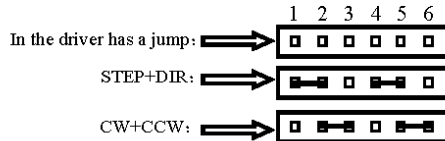

Usually default setting is step + direction.

## Dimension

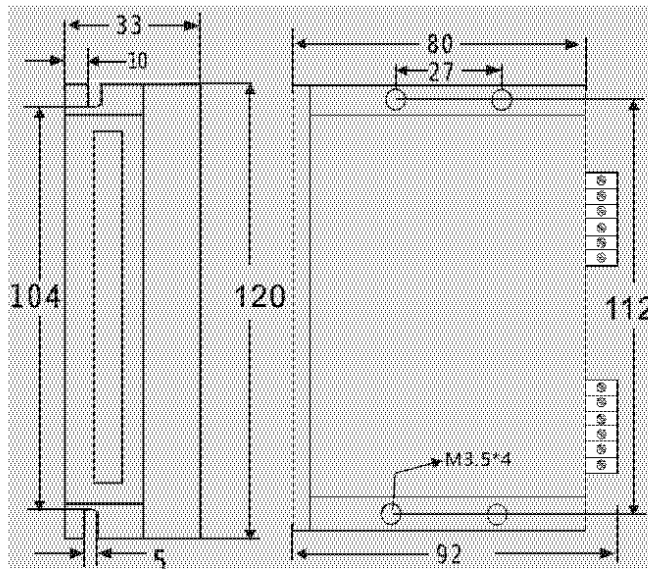

## 2-Phase stepper Motor Driver ST-M5045

### Characteristics:

1. DC power input type: 24V~50V
2. Output current: 1~4.5A
3. Microstep: 2、4、8、16、32、64、128、256、5、10、25、50、125、250
4. Protect form : Overheated protect, Short-voltage, over-voltage, over-current protection
5. The maximum pulse rate is 300KHZ.
6. Dimensions: 120mm\*92mm\*33mm
7. Weight: <280g.
8. Working environment: Temperature-15~40°C Humidity<90%.

### I/O Ports:

- 1、DC+: DC power positive pole  
**Note: Must guard against exceeding 50V, so as not to damage the module.**
- 2、DC-: DC power cathode
- 3、A+、A-: Stepping motor one winding
- 4、B+、B-: Stepping motor other winding
- 5、PUL+、PUL -: Stepping pulse input+5V (Rising edge effective , rising edge duration >10μS)
- 6、DIR +、DIR-: Stepping motor direction input, voltage level touched off, high level forward , low level reverse
- 7、ENA+、ENA-: motor free

### Typical Connection

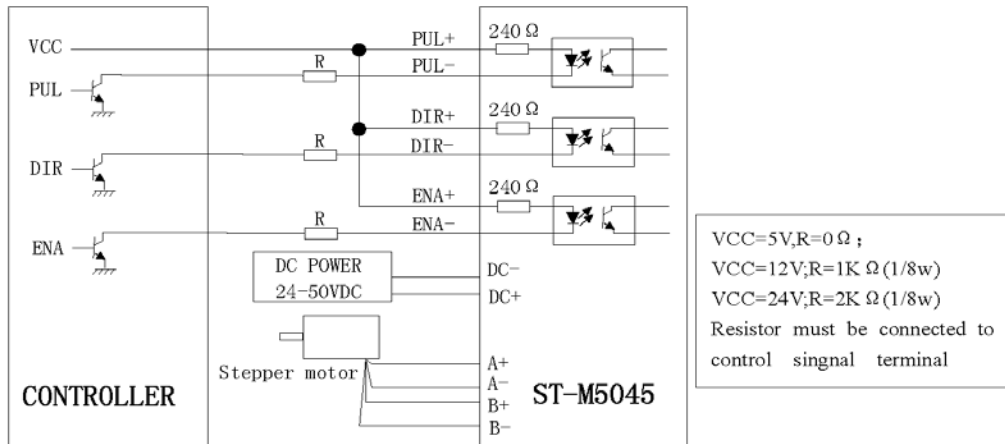

### Switch Choice:

#### 1、Microstep choice:

Microstep	Pulse/rev. (for 1.8° motor)	SW5	SW6	SW7	SW8
2	400	ON	ON	ON	ON
4	800	ON	OFF	ON	ON
8	1600	ON	ON	OFF	ON
16	3200	ON	OFF	OFF	ON
32	6400	ON	ON	ON	OFF
64	12800	ON	OFF	ON	OFF

## B.2 Analysis for Final Design

### B.2.A Electrical Analysis

<http://www.pdfescape.com/open/RadPdf.aspx?rt=c&dk=00F96A31IV7Q...>

## Hybrid Stepper Motor KL23H2100-35-4BM

UNIT=mm

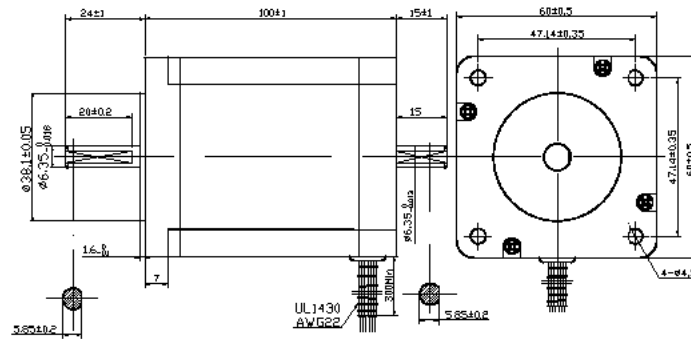

MODEL	PHASLS	STEP	RATED	CURRENT	RESISTANCE	INDUCTANCE	HOLDING	ROTOR	WFTGHT
		ANGLE	VOLTAGE	/PHASE	/PHASE	/PHASE	TORQUE	INERTIA	
		DEC	V	A	Ω	mH	OZ-IN	g·cm	Kg
	2	1.8	4.2	3.5	1.2	6.4	570		1.4

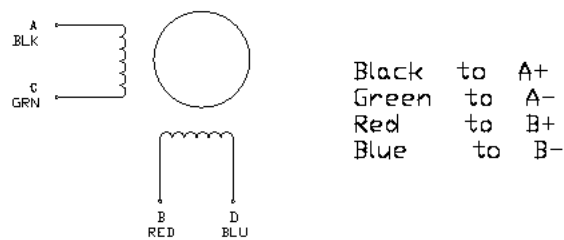





$$V = IR$$

$$I = V/R$$

5V LOGIC (STEPPER DRIVER)

$$R = 240 \Omega$$

$$V = 5V$$

$$I = \frac{5V}{240 \Omega}$$

$$I = 20.8 \text{ mA}$$

3.3V LOGIC (PI, LIMIT SWITCH)

$$R = 10,000 \Omega$$

$$V = 3.3V$$

$$I = \frac{3.3V}{10,000 \Omega}$$

$$I = 0.33 \text{ mA}$$

OHM'S LAW  $V = IR$ 

$$I = V/R$$

 $R_{\text{BODY}} = 1100 \Omega$  FOR HAND TO FOOT

120V LINE

$$I = \frac{120V}{1100\Omega}$$

$$I = 109 \text{ mA}$$

RISK OF VENTRICULAR FIBRATION

24V LINE

$$I = \frac{24V}{1100\Omega}$$

$$I = 21.8 \text{ mA}$$

PAST LET-GO THRESHOLD

5V LINE

$$I = \frac{5V}{1100\Omega}$$

$$I = 4.5 \text{ mA}$$

PAST PAIN THRESHOLD

NO SERIOUS EFFECTS

SUPPORT BOARD CONVECTION  
CALCS

DAVID STRENG

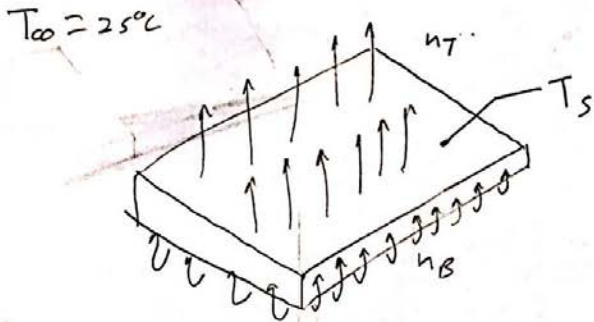

ASSM:  $T_S$  IS UNIFORM  
 $T_{\infty} = 25^{\circ}\text{C}$   
S.S.  
NATURAL CONV.  
IDEAL GAS

THEM. CIRCUIT

$$\dot{q} = \dot{q}_t + \dot{q}_b$$

$$\dot{q} = h_t A (T_S - T_{\infty}) + h_b A (T_S - T_{\infty})$$

$$\dot{q} = (h_t + h_b) A (T_S - T_{\infty})$$

DESIGN SPEC

$$T_S - T_{\infty} \leq 20^{\circ}\text{C}$$

HEAT TRANSFER COEFF.

$$L_c = \frac{A}{P}$$

$$L_c = \frac{(0.1\text{m})(0.08\text{m})}{2(0.1\text{m} + 0.08\text{m})}$$

$$L_c = 0.0222\text{m}$$

RALEIGH NUMBER

$$Ra = \frac{g \beta (T_S - T_{\infty}) L^3}{\nu \alpha}$$

$$g = 9.81\text{m/s}^2$$

$$\beta = \frac{1}{T_f}$$

$$\beta = \frac{1}{308\text{K}}$$

$$\beta = 0.00325$$

$$T_S - T_{\infty} = 20^{\circ}\text{C} = 20\text{K}$$

$$L = 0.0222\text{m}$$

$$\nu = 1.64 \times 10^{-5}\text{m}^2/\text{s}$$

$$\alpha = 22.5 \times 10^{-6}\text{m}^2/\text{s}$$

$$Ra = \frac{9.81\text{m/s}^2 (0.00325 \frac{1}{\text{K}}) (20\text{K}) (0.0222\text{m})^3}{(1.64 \times 10^{-5}\text{m}^2/\text{s}) (22.5 \times 10^{-6}\text{m}^2/\text{s})}$$

$$Ra = 1.89 \times 10^5$$

HEAT GEN.

$$\dot{q} = 0.54\text{W}$$

CALC DONE BY SATUAN PCB

$$\dot{q} = 0.54\text{W}$$

$$T_f = \frac{T_S + T_{\infty}}{2}$$

$$T_f = \frac{45 + 25}{2}$$

$$T_f = 35^{\circ}\text{C}$$

$$T_f = 308\text{K}$$

ALL PROPS EVALUATED  
AT  $T_f$

SUPPORT BOARD CONVECTION  
CALCS

DAVID STRENB

$$h_t: \bar{Nu} = 0.54 Ra^{1/4}$$

$$h_b: \bar{Nu} = 0.27 Ra^{1/4}$$

$$\bar{Nu} = \frac{\bar{h} L}{k}$$

$$\bar{Nu} = \frac{\bar{h} L}{k} = A Ra^{1/4}$$

$$\bar{h} = \frac{k}{L} A Ra^{1/4}$$

$$k_{air} = 26.3 \times 10^{-3} \frac{W}{m \cdot K}$$

TOP PLATE

$$\bar{h}_t = \frac{26.3 \times 10^{-3} \frac{W}{m \cdot K}}{0.0222 m} (0.54) (1.89 \times 10^8)^{1/4}$$

$$\bar{h}_t = 13.3 \frac{W}{m^2 \cdot K}$$

BOTTOM PLATE

$$\bar{h}_b = \frac{26.3 \times 10^{-3} \frac{W}{m \cdot K}}{0.0222 m} (0.27) (1.89 \times 10^8)^{1/4}$$

$$\bar{h}_b = 6.7 \frac{W}{m^2 \cdot K}$$

$$\dot{q} = (h_t + h_b) A (T_s - T_\infty)$$

$$0.54 W = (13.3 + 6.7) \frac{W}{m^2 \cdot K} (0.1 m) (0.08 m) (20) K$$

$$0.54 W < 3.2$$

NATURAL CONVECTION OK

NEED TO BE CHECKED

TOP PLATE

BOTTOM PLATE

TOP PLATE

BOTTOM PLATE

## B.2.B Tank Analyses

### Calculation for the Acrylic Thickness



Any Questions? Please contact our Technical Center at: (207) 490-4230

#### Aquarium Thickness Calculation

All recommendations made herein are believed to be reliable. Such recommendations are made without charge and without warranty, and on the express understanding that CYRO Industries assumes no obligations in connection with any such recommendations.

#### Assumptions

- \* ACRYLITE® GP acrylic sheet is material used
- \* Two part polymerizable cement used to cement parts together
- \* Proper cementing techniques are utilized
- \* Bottom of tank is fully supported
- \* While the tensile strength of the ACRYLITE GP sheet is 10,000 psi at room temperature, continuously imposed loads below that could cause stress crazing and/or failure. Therefore, 750 psi is the design stress used for water applications.

#### Important Considerations

- \* Length "L" is always the longer of the two bottom sides
- \* Tanks with closed tops will require thinner sheet, since the top will provide added support to the tank
- \* If the sides are held together at the top in a frame, it can be considered a closed tank

#### How to use this Spreadsheet

- 1 Enter the height "H" of the tank in inches
- 2 Enter the length "L" of the tank in inches
- 3 Specify whether the top of the tank will be closed
- 4 Thickness of sheet required will be calculated and displayed
- 5 Appropriate standard thicknesses of sheet will be highlighted in blue

\* **Note: Areas you need to fill out are in red**

H	Enter Height of Tank [in]	15	Standard Thicknesses [in]
L	Enter Length of Tank [in]	180	0.060
	Is the top closed? (yes or no)	Yes	0.080
q	Maximum Water Pressure [psi]	0.5415	0.098
L/H	L/H	12	0.118
$\alpha$	Maximum Allowable Stress for Acrylite GP in Aquarium [psi]	750	0.177
$\beta$	$\beta$	0.94	0.236
$T_c$	Thickness of Sheet required with top [in]	0.391	0.354
			0.472
			0.591
			0.708
			0.944
			1.250
			1.500
			2.000

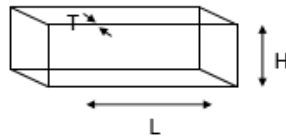

[www.sdplastics.com/cyro/aquarium/Aquarium.xls](http://www.sdplastics.com/cyro/aquarium/Aquarium.xls), CYRO is a large and trusted supplier of acrylic. The length of 180 in. is the length of non-coastline water channel, and the height is the 1.5x nominal water height.

Calculation for the volume, weight and pressure of the water within the tank

Length [ft]	Length [in]	Width [in]	Height [in]	Volume [gal]	Weight [#]	P_Bottom[psi]	P_wall_max [psi]
15	180	6	10	46.447	388.300	0.360	0.360
15	180	6	15	69.671	582.450	0.539	0.539

Figure x. Table of water volume and loads

## Sample Calculations

### Givens

Density of water =  $\rho = 1.931$  [slg/ft<sup>3</sup>]

Length of Tank = 15 ft. = 180 in.

Width of Tank = 6 in.

Max water depth = 10 in.

Conversion from in<sup>3</sup> to gallons: 1in<sup>3</sup> / 0.00433 gal

Weakest tensile strength of wood = 300 psi

\* Cottonwood, <http://www.woodworkweb.com/woodwork-topics/wood/146-wood-strengths.html>, this is the weakest wood, thus it is a safe estimate to use.

### Finding Water Volume:

$$V = l * w * d = 180 \text{ in.} * 6 \text{ in.} * 15 \text{ in.}$$

$$V = 16200 \text{ in}^3 = 9.4 \text{ ft}^3$$

$$V = 69.671 \text{ gal}$$

### Weight of the Water Volume:

$$W = (\rho * V) * g$$

$$W = \left( 1.931 \frac{\text{slg}}{\text{ft}^3} * 9.4 \text{ ft}^3 \right) * 32.174 \frac{\text{ft}}{\text{s}^2}$$

$$W = 582.45 \text{ lbf.}$$

### Pressure seen on the bottom of the tank:

$$P = \frac{W}{A} = \frac{W}{l * w}$$

$$P = \frac{582.45 \text{ lbf}}{180 \text{ in} * 6 \text{ in}}$$

$$P = 0.539 \text{ psi}$$

\* This is also the same pressure seen at the bottom of the side panels

\*\* This is much smaller than the wood's capability, thus should not pose a concern as long as the bottom of the tank is supported in the middle minimizing bending moments.

## B.2.C Coastline Analysis

COASTLINE BUOYANCY ANALYSIS

JOHN HENGLER 5/4/17

### SCHEMATIC

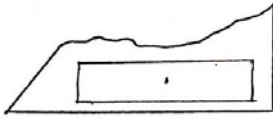

### ASSUMPTIONS

- ASSUME COASTLINE FULLY SUBMERGED IN WATER

### GIVEN

- $V_{\text{coastline}} = 0.02 \text{ m}^3$
- $\rho_{\text{coastline}} = 0.3 \text{ g/cm}^3$
- $\rho_{\text{water}} = 1 \text{ g/cm}^3$

### ANALYSIS

#### FRD

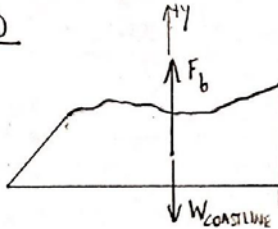

$$+\uparrow \Sigma F_y = W_{\text{mass}}$$

$$W_{\text{mass}} = F_b - W_{\text{coastline}}$$

$$W_{\text{mass}} = \rho_{\text{water}} V_{\text{coastline}} g - \rho_{\text{coastline}} V_{\text{coastline}} g$$

$$m_{\text{mass}} g = \rho_{\text{water}} V_{\text{coastline}} g - \rho_{\text{coastline}} V_{\text{coastline}} g$$

$$m_{\text{mass}} = 19 \text{ kg}$$

$$\text{SF} = 3$$

$$m_{\text{curr}} = 42 \text{ kg}$$

- CALCULATES EXTRA WEIGHT  $W_{\text{mass}}$  REQUIRED TO HOLD DOWN COASTLINE UNDERWATER

- ADDS SAFETY FACTOR TO ACCOUNT FOR UPLIFTING FORCE OF WAVE

→ 42 kg OF EXTRA MASS IS REQUIRED TO HOLD COASTLINE DOWN



## B.2.D Support Structure Analysis

SUPPORT STRUCTURE ANALYSIS

JOHN NIEMOLLER 5/4/17

SCHEMATIC

TIP-OVER ANALYSIS

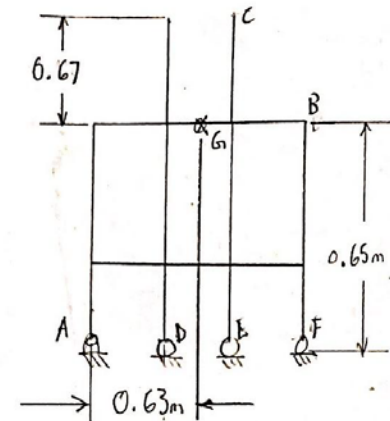

ASSUMPTIONS

- D, E, F REACTIONS NEGLECTED FOR MAX TIP OVER LOADING CONDITION

EBD

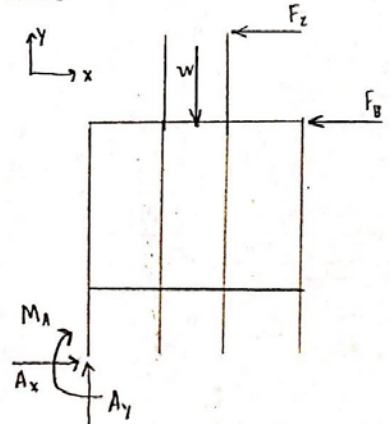

$$m = 1530 \text{ kg}$$

$$W = (9.81 \text{ m/s}^2)(1530 \text{ kg})$$

$$W = 5200 \text{ N}$$

TIP OVER FROM ONLY FORCE AT B

$$\sum M_A = 0$$

$$0 = 0.63 \text{ m}(5200 \text{ N}) - F_B(0.65 \text{ m})$$

$$F_B = 5040 \text{ N}$$

TIP OVER FROM ONLY FORCE AT C

$$\sum M_A = 0$$

$$0 = 0.63 \text{ m}(5200 \text{ N}) - F_C(0.67 \text{ m} + 0.65 \text{ m})$$

$$F_C = 2980 \text{ N}$$

# B.2.E Wedge Dynamics

## WEDGE DYNAMICS ANALYSIS

JOHN NIEMOLTER SP117

### SCHEMATIC

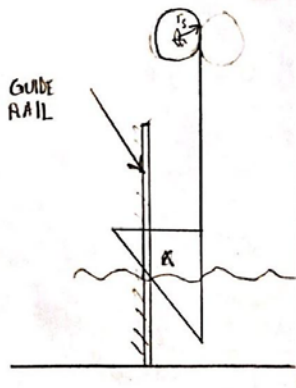

### ASSUMPTIONS

- WEDGE OSCILLATES VERTICALLY
- GUIDE RAIL FRICTION NEGLECTED / MOMENT NEGL.
- MAX LOADING OCCURS WHEN WEDGE IS FULLY OUT OF WATER

### GIVEN

$$r_s = 0.016 \text{ m}$$

$$m_w = 0.534 \text{ kg}$$

$$M_{\text{max}} = 2 \text{ N}\cdot\text{m}$$

$$g = 9.81 \text{ m/s}^2$$

← MAX TORQUE THAT CAN BE DELIVERED TO MOTOR

### ANALYSIS

#### FBD SPRUCKET

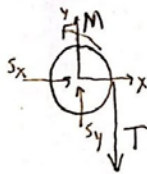

$$\sum M_s = M$$

$$M = T r_s$$

$$T = \frac{M}{r_s}$$

• CALCULATES BELT TENSION

#### FBD WEDGE



$$\sum F_y = 0$$

$$0 = T - W$$

$$\frac{M}{r_s} = m_w g$$

$$M = m_w g r_s$$

$$M = 0.0846 \text{ N}\cdot\text{m}$$

• CALCULATES OPERATING MOTOR TORQUE, M

$$M = 0.0846 \text{ N}\cdot\text{m} \ll M_{\text{max}} = 2 \text{ N}\cdot\text{m} \quad \checkmark$$

# Attachment C: FMEA

Team:	Seismic Surge Wave Tank
Date last Revised:	4/6/2017

Failure Mode Element Analysis						
Item/Function	Failure Mode	Potential Effects	Severity	Potential Causes	Occurrence	Recommended Actions
Tank	rupture	flooding	8	dynamic loading fatigue	2	Design tank for fatigue
		trip hazard	8	kids and other visitors	8	Large Factor of Safety, tank design
	leaking	shorts, wood damage	8	improper seal	6	Waterproofing guidelines, design for repair
Mechanism	corrosion	high friction	5.5	improper materials	6	Material selection, sealability
	jamming	doesn't work	4	dirt, debris	2	Minimize exposed moving parts
	misalignment	mechanism damage	5	poor assembly, poor constraints	3	Design, manufacturing
	belt wear (teeth)	stops working	3	fatigue	4	Maintenance
Mechantronics	motor slips	inaccurate positioning	3	low torque	5	Encoder, FS
		damage components	2	high accelerations	5	Encoder, frequency limit
	overheating	shutdown	2	inadequate airflow	5	Increase airflow
		damage electronics	8	poor heat transfer	5	Heatsinks
	current/voltage fluctuation	brown outs, damage	6	shorts	4	Implement Fuse
	corrosion	damage to electronics	6	high current draw	10	Use filters
	software bugs	poor control	varies	high humidity, poor solder joints	4	Design for ventilation, and cover joints
Structure	tipping over	injury and property damage	10	coding byproduct	10	Go through extensive testing and debugging
		injury and property damage	5	not locked	2	Ensure adequate restraints when in use,
	joint yield	injury and property damage	6	poor stability	4	Stable design
		injury and property damage	6	poor design	3	Good initial design
				poor manufacturing	6	Inspect welds

# Attachment D: Estimated Bill of Materials

Bill of Materials					
Assembly	Part	Quantity	Price Each	Total Price	Supplier
Electrical	sheet aluminum (24x12)	1	26.53	26.53	mcmaster
	rivet	1 pkg	11.32	11.32	mcmaster
	screw m2.5	1 pkg	4.13	4.13	mcmaster
	nuts m 2.5	1 pkg	2.22	2.22	mcmaster
	screw m4	1 pkg	4.85	4.85	mcmaster
	nut M4	1 pkg	1.32	1.32	mcmaster
	raspberry pi	2	-	-	already have
	nema 23 (motor)	1	-	-	already have
	logic converter	2	-	-	already have
	power supply	1	-	-	already have
	st-m5045	1	-	-	already have
	raspberry pi screen	1	64.95	64.95	sparkfun
	5V converter	1	8.95	8.95	pololu
	12 V converter	1	7.49	7.49	pololu
	0.1 uf capacitor	2	0.25	0.50	ddigikey
	10 uf capacitor	2	0.21	0.42	digkey
	molex kk header	2	0.23	0.46	digkey
	pi shrouded header	1	0.95	0.95	sparkfun
	male headers	1	1.50	1.50	sparkfun
	female headers	1	1.50	1.50	sparkfun
	1x2 terminal block	6	0.75	4.50	sparkfun
	spacers pack	1	1.79	1.79	pololu
	3.5 MM SCREW	1	4.13	4.13	mcmaster
	22 gauge wire (red and black)	2	5.00	10.00	pololu
	female crimps	1	5.95	5.95	pololu
	1x4 crimp connector	1	0.79	0.79	pololu
	1x6 crimp connector	1	0.79	0.79	pololu
Coastline	RenShape Foam 30lb Density	1	\$100	\$100	freeman supply
	Silver Nanoparticle 0.02mg/mL Solution	1	\$100	\$100	sigma-aldrich
	Steel Weight	1	\$100	\$100	scrap/mcmaster
	Flex Seal	1	\$50	\$50	home depot

## Bill of Materials

Assembly	Part	Quantity	Price Each	Total Price	Supplier
Mechanism	belt	1	6.43	6.43	mcmaster
	pulley, D shaft	1	15.30	15.30	grainger
	pulley, free	1	6.20	6.20	mcmaster
	ABS rod	5	0.50	2.50	mcmaster
	bushings	2	1.81	3.62	mcmaster
	bracket material	1	6.89	6.89	mcmaster
	screws	1	11.71	11.71	mcmaster
	Guide rods	6	0.27	1.62	usplastic
	screws bottom	1	7.59	7.59	mcmaster
	stainless hex	1	3.71	3.71	mcmaster
	aluminum sheet	6x24	6.36	6.36	mcmaster
	motor bracket	1	6.36	6.36	pololu
	1/4-20 corrosion resistant rod	1	2.04	2.04	mcmaster
	1/4-20 corrosion resistant nut	1	3.76	3.76	mcmaster
Tank Body	1/2" x 24" x 96" acrylic	1	204.00	204.00	American Plastics Corp.
	1/2" x 24" x 24" acrylic	1	53.00	53.00	American Plastics Corp.
	Pack of plastic syringe	1	9.68	9.68	Amazon
	Eco-Bond Caulk	2	12.75	25.50	Home Depot
	1/4" x 1" 316 SS wood screw	1	10.44	10.44	Mccmaster Carr
	1/4" 316 SS washer	1	7.29	7.29	Mccmaster Carr
	1/4" Buna-N o-ring	1	2.29	2.29	Mccmaster Carr
	1/2' 4' x 8' hardwood plywood	4	24.98	99.92	Home Depot
	1/8" x 48 x 96" PVC sheet	3	133.00	399.00	Tap Plastics
	Weld-On Heavy Duty PVC Cement	1	7.99	7.99	Home Depot
	steel corner bracket	30	0.58	17.40	Home Depot
	#9 x 5/8" wood screws	2	5.83	11.66	Mccmaster Carr
	2" x 4" x 16' wood	6	6.98	41.88	Home Depot
	1" x 2" x 8' wood	5	2.58	12.90	Home Depot
	2" x 6" x 12' wood	3	7.85	23.55	Home Depot
	30' soft white rope lights	1	31.95	31.95	Amazon
	6.6' soft white rope light	1	16.95	16.95	Amazon
	6 ft. extension cord	1	6.26	6.26	Amazon
	Black Pond Shield, 1.5 Quart	1	75.95	75.95	Pond Armor
	Gorilla Wood Glue	4	3.87	15.48	Amazon
	3/4" - 1" PVC coupler	1	2.37	2.37	Home Depot
	1" Rubber stopper	1	1.33	1.33	Home Depot
	1 sq. yard Fiberglass Cloth	2	9.98	19.96	Amazon
0.04" x 18" x 9" Aluminum Sheet Metal	1	9.98	9.98	Home Depot	
Gas money to pick up Acrylic and PVC Stock	1	140.00	140.00		

	Fiberglass Resin	1	75.00	75.00	West Systems
--	------------------	---	-------	-------	--------------

<b>Total:</b>	1920.86
---------------	---------

# Attachment E: Gantt Chart

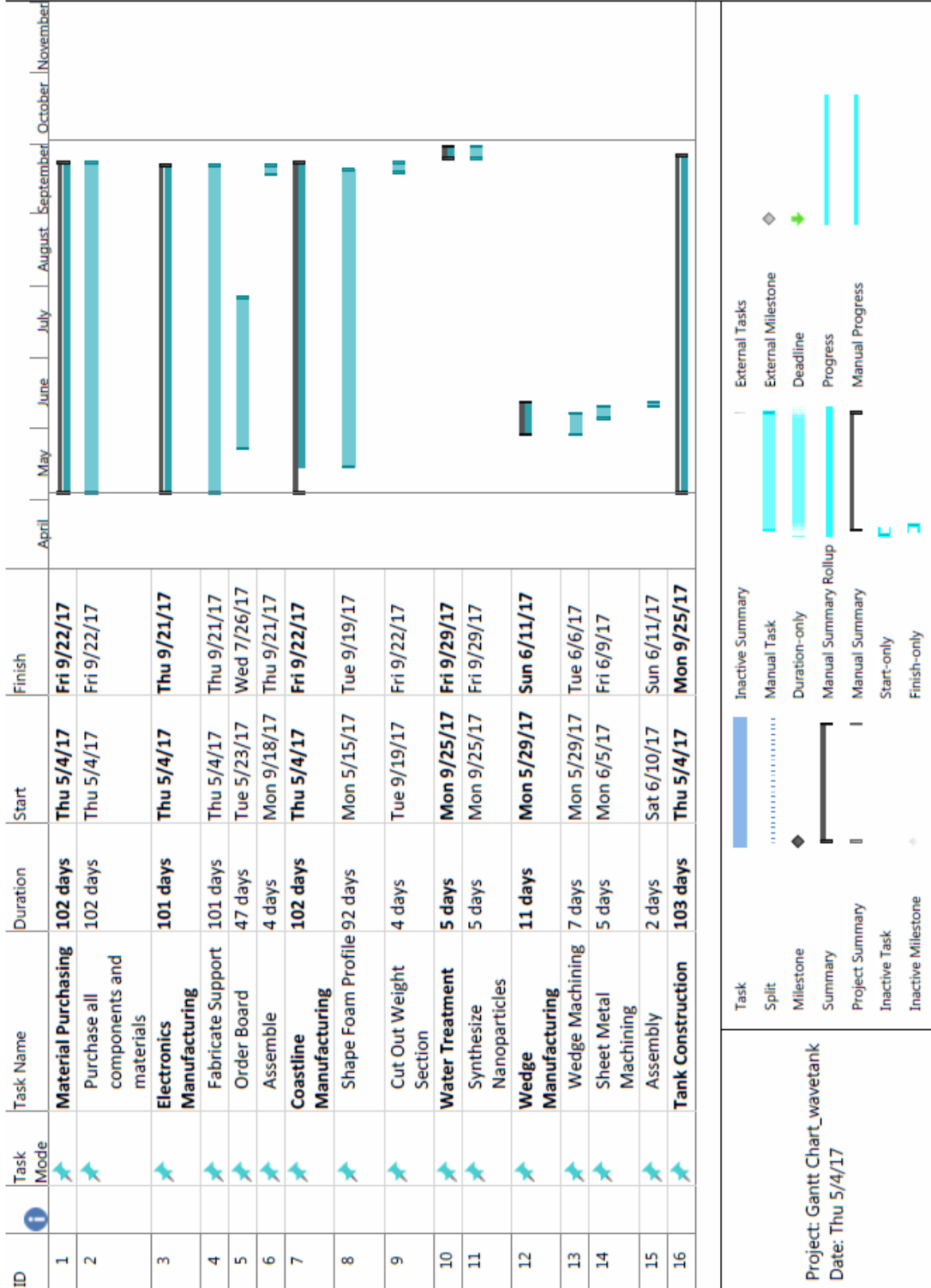

ID	Task Mode	Task Name	Duration	Start	Finish	April	May	June	July	August	September	October	November
17	★	Fabricate Parts	100 days	Thu 5/4/17	Wed 9/20/17								
18	★	Assemble Tank	4 days	Wed 9/20/17	Mon 9/25/17								
19	★	<b>Testing</b>	<b>52 days</b>	<b>Sat 7/22/17</b>	<b>Mon 10/2/17</b>								
20	★	Wedge Testing	1 day	Mon 9/18/17	Mon 9/18/17								
21	★	Tank Seal Testing	7 days	Mon 5/22/17	Tue 5/30/17								
22	★	Mechanism and Electronics Testing	3 days	Thu 9/21/17	Sun 9/24/17								
23	★	System Testing	6 days	Mon 9/25/17	Mon 10/2/17								

Project Gantt Chart\_wavetank  
Date: Thu 5/4/17

Task	Inactive Summary	External Tasks
Split	Manual Task	External Milestone
Milestone	Duration-only	Deadline
Summary	Manual Summary Rollup	Progress
Project Summary	Manual Summary	Manual Progress
Inactive Task	Start-only	
Inactive Milestone	Finish-only	



# Attachment F: References

- Edinburgh Designs, Commercial Hydrodynamic Testing <http://www.edesign.co.uk/> , accessed February 2017
- Figure 1, Figure 2; Edinburgh Designs, Wave Generators, <http://www.edesign.co.uk/waves/some-wave-1/> accessed February 2017
- Figure 10: The Geographer Online, Waves, <http://www.thegeographeronline.net/coasts.html> accessed March 2017
- Figure 11: Florida Institute of Technology, Cross Shore Sediment Transport Time Lapse, <https://ecurrent.fit.edu/blog/campus/ocean-engineering-sciences/wavetank/cross-shore-sediment-transport-time-lapse>
- Electrical Safety in the Workplace, United Auto Workers
- Figure : raspberrypi.org <https://www.raspberrypi.org/products/raspberry-pi-2-model-b/>
- Figure : Pololu Robotics and Electronics <https://www.pololu.com/product/2858/specs>
- Figure : [element14.com https://www.element14.com/community/docs/DOC-78156/l/raspberry-pi-7-touchscreen-display](https://www.element14.com/community/docs/DOC-78156/l/raspberry-pi-7-touchscreen-display)
- Figure : Automation Technology inc. <http://www.automationtechnologiesinc.com/products-page/nema-23/nema23-570ozin-5a-14%E2%80%9D-dual-shaft-stepper-motor-kl23h2100-35-4bm/>
- Figure : aliexpress.com <https://www.aliexpress.com/item-img/CNC-mach3-usb-4-Axis-Kit-ST-M5045-3-Axis-Stepper-Motor-Driver-replace-M542-2M542/32326227586.html#>
- Figure : adafruit [https://www.adafruit.com/product/757Any?hidden=yes&main\\_page=product\\_info&part\\_id=757&qclid=Cj0KEQjwoqvlBRD6ls6og8qB77YBEiQAcqgHe8q\\_YsKU0KoATh8PnE6N-C7M5zQX\\_4vFNRLC9oj5aiQaAISD8P8HAQ](https://www.adafruit.com/product/757Any?hidden=yes&main_page=product_info&part_id=757&qclid=Cj0KEQjwoqvlBRD6ls6og8qB77YBEiQAcqgHe8q_YsKU0KoATh8PnE6N-C7M5zQX_4vFNRLC9oj5aiQaAISD8P8HAQ)
- Figure : newegg <https://www.newegg.com/Product/Product.aspx?Item=9SIA98C3SU1512>
- Figure 31: digikey <https://media.digikey.com/Photos/STMicro%20Photos/X-NUCLEO-IHM03A1.jpg>

- Figure 32: STMicroelectronics

[http://www.st.com/content/ccc/fragment/product\\_related/rpn\\_information/board\\_photo/3d/21/e3/7c/b0/43/43/2b/powerSTEP\\_image.jpg/files/powerSTEP\\_image.jpg/\\_jcr\\_content/translations/en.powerSTEP\\_image.jpg](http://www.st.com/content/ccc/fragment/product_related/rpn_information/board_photo/3d/21/e3/7c/b0/43/43/2b/powerSTEP_image.jpg/files/powerSTEP_image.jpg/_jcr_content/translations/en.powerSTEP_image.jpg)

- Figure 33: digikey

[https://media.digikey.com/Photos/Trinamic%20Motion%20Control%20Photos/MFG\\_TMCM-1181.jpg](https://media.digikey.com/Photos/Trinamic%20Motion%20Control%20Photos/MFG_TMCM-1181.jpg)

- Incropera, Frank P., and David P. DeWitt. *Introduction to Heat Transfer*. Hoboken, NJ: Wiley, 2009. Print.
- Saturn PCB Toolkit. Saturn PCB Design, Inc
- Prashant, Jain, and T. Pradeep. *Potential of Silver Nanoparticle-Coated Polyurethane Foam As an Antibacterial Water Filter*. [Interscience.wiley.com](http://Interscience.wiley.com). Indian Institute of Technology Madras, 18 Feb. 2005. Web. 4 May 2017.

# Attachment G: Task Diagram and Finite State Machines

## Task Diagram

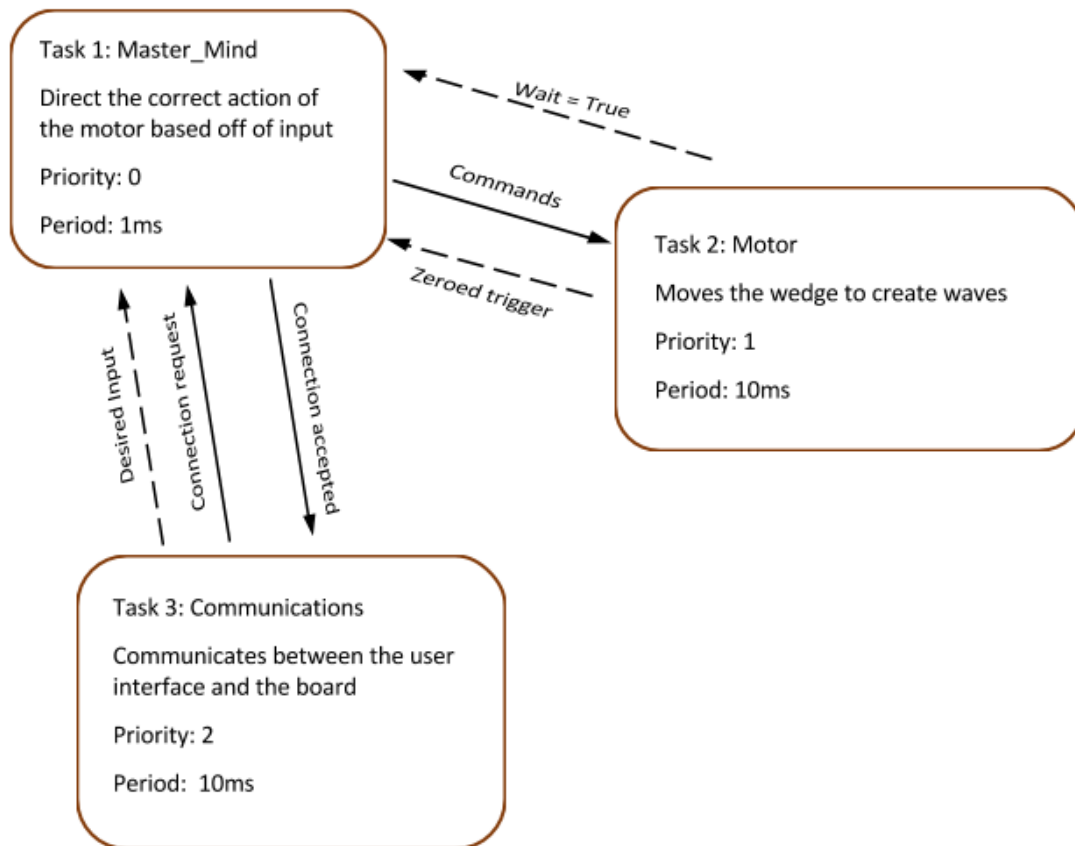

## Task 1: Master\_Mind

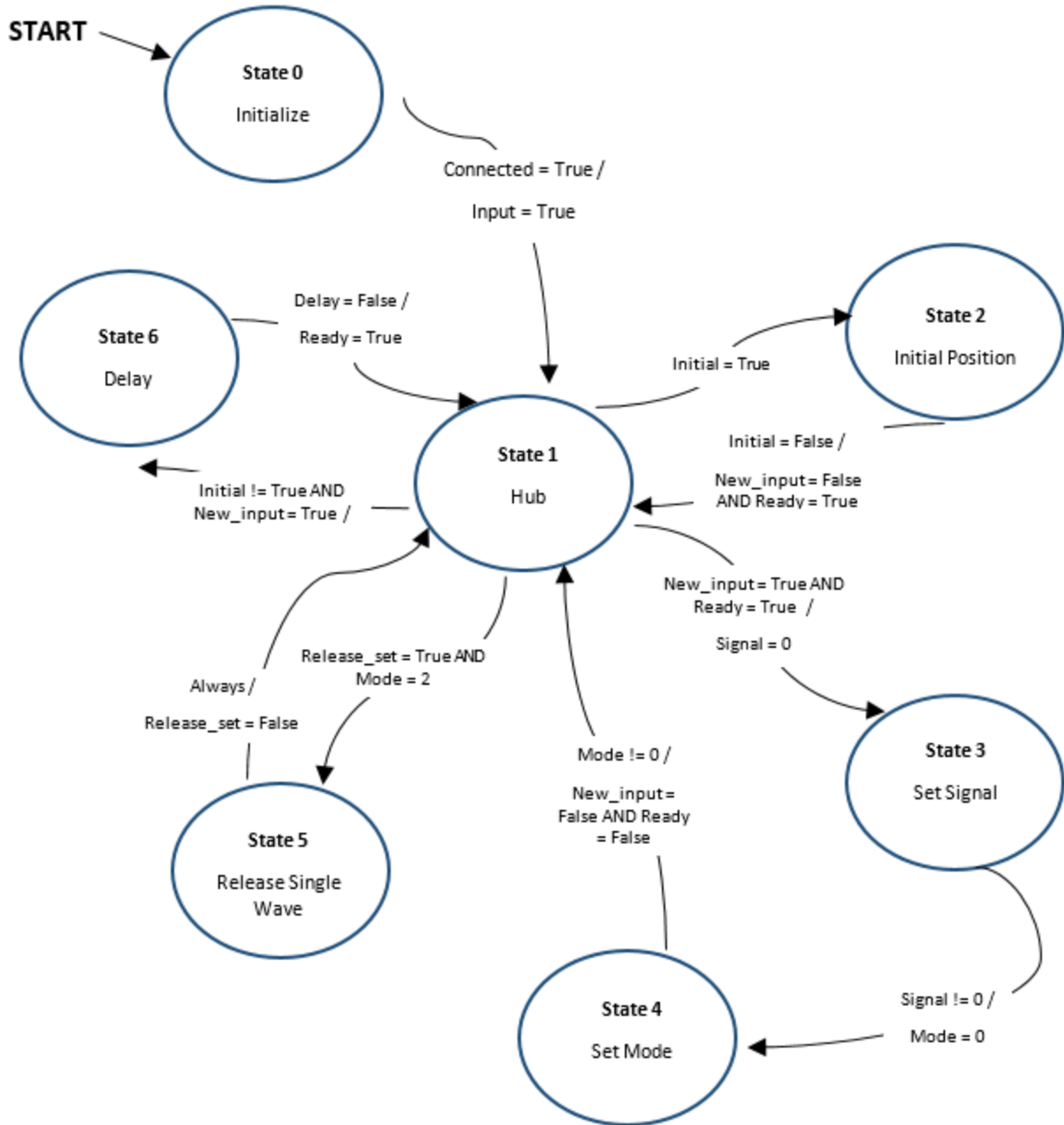

## Task 2: Motor

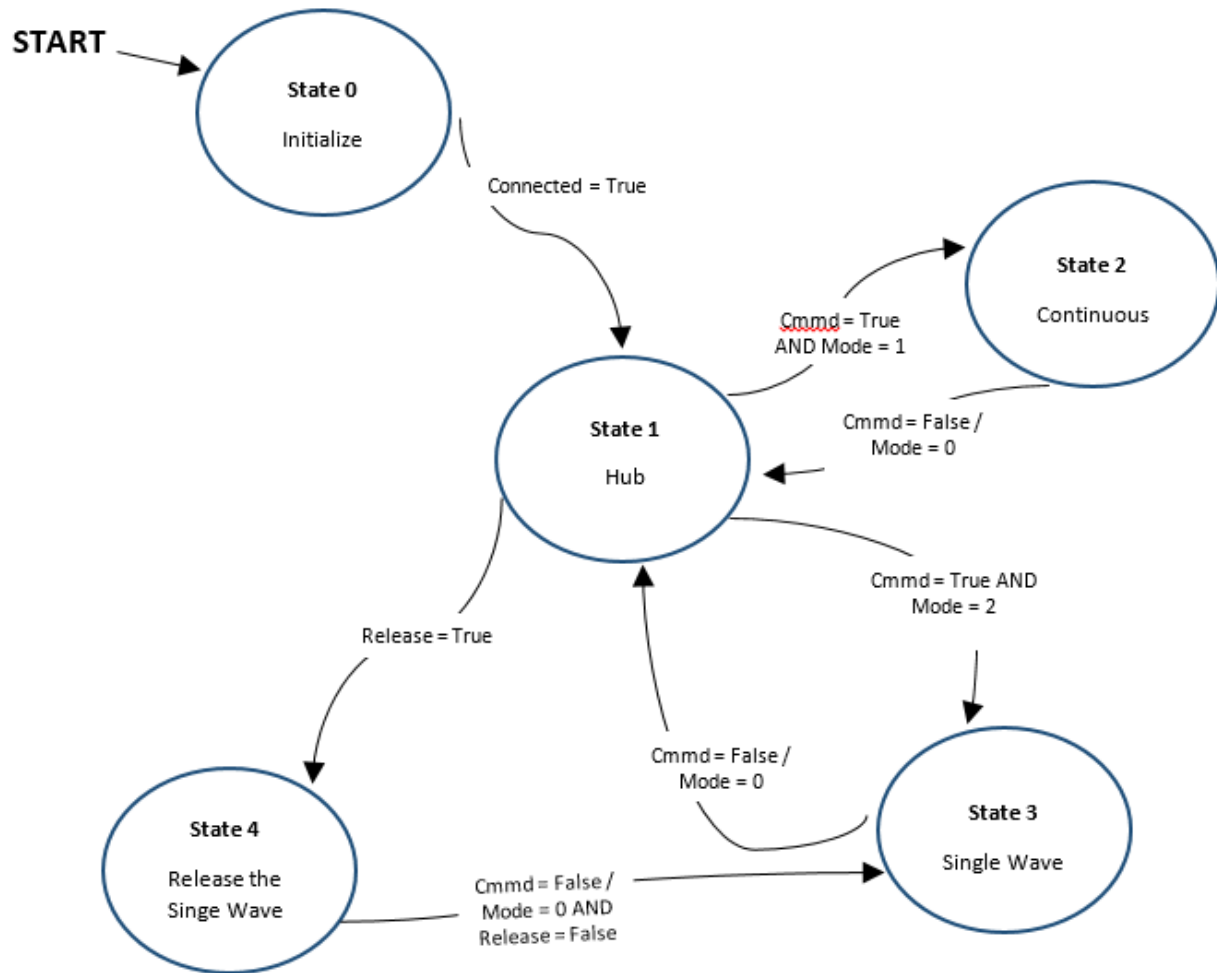

### Task 3: Communications

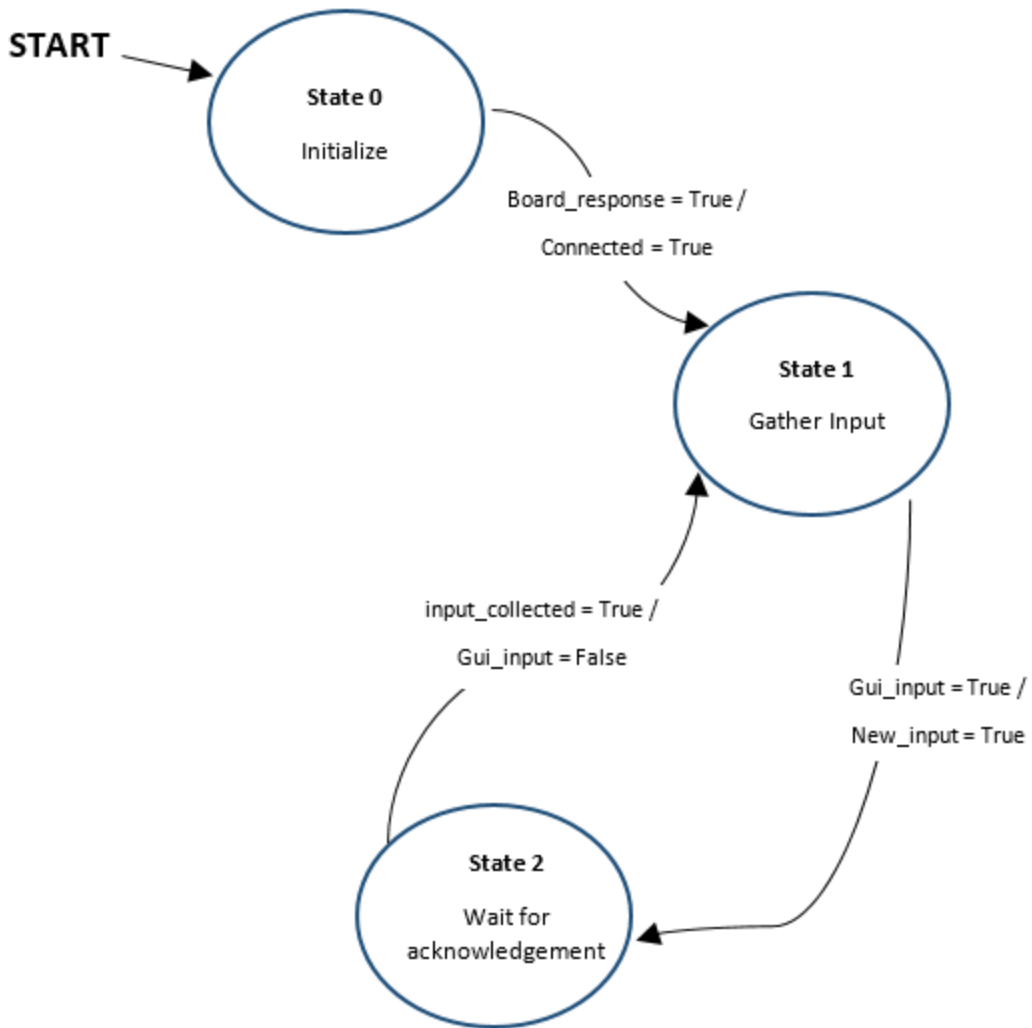

# Attachment H: Drawings

**Note:** although the electronics and mechanism have been revised, the original drawings are still present. The revised files have been placed in the front of this attachment

# Attachment I: Purchases

<u>Item</u>	<u>Purpose</u>	<u>Vender</u>
12" x 12" x .125" PVC Sheet	Practice laminate for Tank	Home Depot
Fiberglass stips, 1/2" x .063"	Practice for tank edge sealing	Home Depot
6'x9' canvas	tarp to cover practice tank	Home Depot
kwik seal	seal to practice tank	Home Depot
Fiberglass cloth	prototype tank edge seal	Home Depot
fence board	prototype tank walls	Home Depot
1"x2" wood	prototype wood walls	Home Depot
epoxy and sealent applicator	applying acrylic solvent	Amazon
acrylic solvent	glueing acrylic	Amazon
flex seal	Rubber coating for sealing tank	Amazon
Mcmaster batch; 0601RJORSTAD	first big hardware order of stuffs	McMaster
Sparkfun batch	electrical hardware batch	Sparkfun
Pololu Batch	electrical hardware	Pololu
Mcmaster Batch		
0501LISADISCHINGER	Material for practice tank	McMaster
Amazon Sealing batch	Flex seal and brushes for sealing the tank	Amazon
Pond Shield	Water Proofing large surfaces will be used to cool our electronics	Amazon
80mm computer fan		Amazon
40 ft. of white LED rope, and such	To light up the tank	Amazon
Water proof cover	to house the drain spicket	Amazon
Limit Switches	Sensor used to zero the mechanism	Amazon
Wide masking tape and micro fiber cloth	used to create clean sealent seams and clean the window	Amazon
60ml syringe	used to get sealent into ticgt corners	Amazon
initial Hardware	Initial materials for the full tank	Home Depot
Acrylic and PVC Sheets	window and laminate material	American Plastics Corp
Two Flex seal Cans	Sealant	Ace Hardware
Flex seal Can	Sealant	Ace Hardware
Flex Seal Can	Sealant	Ace Hardware
Initial wood for the Tank	Sealant	Ace Hardware
Hardware and wood	Materials for putting tank together	Home Depot



More wood board, hardware, liquid nails	Already ran out of material or needed better material	Home Depot
Caulk	needed more to seal the edges	Home Depot Home Depot Home Depot
Sainsmart st-m5045	replacement motor driver	amazon
sheet metal & fastners	electronics housing and mechanism	Ace hardware
sheet metal	electronics housing	Ace hardware
wire and assorted fastners	electronics	ace hardware
A sar micro	electronics	Pololu
copper board	electronics prototypeing	Cal Poly IEEE
mcmaster order 1107DSTRENG	electronics housing	Mcmaster
support board PCB: Streng_Dischinger_Niemoller_final	electronics	Oshpark
Timing Belt, XL Series, 1/4" Wide, (2)	Mechanism	Mcmaster Carr
Corrosion-Resistant Rotary Shaft, 303 Stainless Steel, 1/4" Diameter, 3" Long	Mechanism	Mcmaster Carr
Zinc-Galvanized Low-Carbon Steel 90 Degree Angle, 1/4" Wall Thickness, 1-1/2" x 1-1/2" Outside Size, 1 Foot Long	Mechanism	Mcmaster Carr
PVC Sheet, 6" x 6" x 1"	Mechanism	Mcmaster Carr
Super-Corrosion-Resistant 316 Stainless Steel Threaded Rod, 1/4"-20 Thread Size, 8" Long, packs of 1	Mechanism	Mcmaster Carr
Clear Cast Acrylic Bar, 1" Wide x 1/2" Thick, 4 Feet Long	Mechanism	Mcmaster Carr
ABS Rod, 1/4" Diameter, Black, 5 ft. Length	Mechanism	Mcmaster Carr
Corrosion-Resistant Timing Belt Pulley, XL Series, 1.000" OD	Mechanism	Mcmaster Carr
Assorted fasteners	Mechanism	Ace Hardware
Assorted fasteners	Mechanism	Ace Hardware
Assorted fasteners	Mechanism	Ace Hardware
Aluminum tube 3/16 X 0.35 X 36	Mechanism	Ace Hardware
Aluminum tube 5/16 X 0.35 X 36	Mechanism	Ace Hardware

---

**Total Spent:**  
**Amount Left:**

<u>Cost</u>	<u>Purchaser</u>	<u>Date</u>
16.98	Lisa	4/7/17
1.4	Lisa	4/7/17
13.98		
5.97		
6.97		
3.91		
0.98	Lisa	4/11/17
5.95		
12.04		
14.99	Lisa	4/13/17
237.4	Jorstad	06/01/2017
	Jorstad	5-2017
35.96	Jorstad	5-30-2017
29.54	Lisa	5/1/17
20.02	Lisa	9/25/17
71.94	Lisa	9/29/17
6.34	Lisa	10/16/17
52.01	Lisa	11/1/17
14.49	Lisa	11/6/17
5.95	Lisa	11/6/17
7.53	Lisa	11/10
7.49	Lisa	11/10/17
68.78	Lisa	5/1/17
934	Jorstad	9/5/17
36.72	Lisa	11/13/17
17.23	Lisa	10/15/17
17.23	Lisa	10/14/17
90.91	Lisa	5/25/17
66.97	Lisa	9/20/17

104.73	Lisa	9/25/17
25.29	Lisa	9/29/17
73.07	Lisa	10/02/17
11.07	Lisa	10/06/17
37.99	David	9/18/17
33.56	David	10/31/17
28	David	11/09/17
16.97	David	10/31/17
35.2	David	10/17/17
3.5	David	10/27/17
17.96	David	11/7/17
30	David	11/17/2017
26.04	Jack	10/26/17
4.12	Jack	10/26/17
13.22	Jack	10/26/17
11.42	Jack	10/28/17
1.7	Jack	10/28/17
9.68	Jack	10/28/17
3.9	Jack	10/28/17
17.2	Jack	10/28/17
6.94	Jack	10/29
4.74	Jack	10/26
2	Jack	10/24
8.1	Jack	11/1
8.2	Jack	11/1

---

2338.28

2161.72

## Attachment J: Verification Plan

### Mechanism Check List

- Power outlet visually looks intact
- All cables are not frayed
- The belt is not feel over stretched
- The belt does not have accesive wear
- Move the system a couple of times checking that it moves relatively smoothly
- Check that the motor mount is fully locked down in place

### Tank Structure Check List

- Ensure that the tank is fully on a stable surface
- Walk around the structure and see if anything looks crooked or out of place
- Do a quick check of the light plug in and that it is far away from water
- Check that there are no cracks in the glass
- Make sure that all metal top cross beams are in place before filling up with water

### Water Tank Fill procedure

- Ensure that the drain valve is closed
- Fill up with water up to the initial step, that would be about 2 in.
- Wait for 5 minutes to see if there are any leaks
  - If there are leaks, apply enough food coloring to the water and keep the water in until it is noticed that colored water is leaking out
  - Drain the water and follow the "Hunt for Water Leaks" steps
- Fill up with water such that the water level is about 1 inch is visible when looking from
  - If there are leaks, apply enough food coloring to the water and keep the water in until it is noticed that colored water is leaking out
  - Drain the water and follow the "How Hunt for Water Leaks" steps
- Fill up with water up to the desired water height. We found that 8 to 10 inches works w
- Leaks will sometimes take a long time to show themselves or will only occur when it gets cold, just keep an eye out for them
- When you are done drain the tank, and pat dry the inside as much as possible

### Water Treatment Checklist

- The solution will remain antimicrobial
- The solution can be dyed with color

### Water Treatment Test procedure:

- Acquire industrial grade silver nanoparticle antimicrobial solution
- Place the solution in a glass beakerin in an indoor environment that's well lit for atleast
- Observe solution behavior and document solution condition over the course of the test

### Electronics and Software Check List

- Check that there are no frayed cables
- Check that all the componants are securly attached to the electronics housing box
- Make sure that the screen is very securly attached to the front face of the box
- Check that the fan turns on and is ventalating the inside

- Ensure that the electronics are safely away or protected from the water
- Have someone watching the mechanism when it is initially turned on
- Zero the mechanism against the top limit switch

## How to Hunt for Water Leaks

### Depending on where the leak comes out there are two main failure spots

1. If water is leaking out the bottom or through the wood that mostly means that the bottom area of caulk and seal, I would check where the bottom plates of PVC meet the wood.
2. If water is coming out of the front seam where the wood meets the window, there is a crack on the inside where the glass sits on the wood shelf and caulk is there but it is not sealed properly.

### Overall method is as follows

Drain and closely inspect for tears in the flex seal or caulk as you are pat\* drying

\*It is best to pat dry since the caulk and flex seal sometimes like to rub off, so pat and not rub

Do a second inspection round looking for if you can see remnants of colored water. Also sometimes the water will drip back out into the tank, follow the stream to its source. Specifically for when there is a leak of scenario #2 from above, take out a vacuum and watch where the water is coming from to get to that point, then since I did not fully caulk the contact face. This will help you somewhat understand the range that the leak could be within.

When all else fails you can just glob silicon caulk everywhere of interest and wait to try again, the more sure way is to use flex seal since that leaks into any crevice in the tank a slight bit such that the seal will be able to flow in and sit there while it cures. Flex seal takes 24 hours to fully cure.

### Software Verification

#### 1) Amplitude Calibration

Run continuous waves at 1Hz and vary the amplitude. For each wave amplitude find the percentage difference between desired and actual wave.

In control program, or GUI multiply wave amplitude by correction factor.

$$Cf = (100 - \%diff) / 100 + 1$$

IE, if wave is only 80% of desired amplitude, multiply amplitude by 1.25

#### 2) Frequency Calibration

Similarly to amplitude calibration, run continuous waves at fixed amplitude and frequency. Use a stopwatch to measure time between peaks or troughs to find the period. frequency = 1/Period. Apply correction factor as in Amplitude calibration

#### 3) Endurance test

Run mechanism for 3 hours at peak wave amplitude and frequency. Drift should be minimal. Note: don't leave the tank during this test. If the mechanism runs into the bottom damage could occur.

the front

vell

: 3 months  
ting duration

t there is a crack in  
neet  
iat means that there  
ridging the two

o it is better to pat

er below the caulk  
s source  
nd run it along the  
re are many tunnels  
d where the leak is

12 hours before  
s. It is best to tip the  
s. Take note that flex

ude, use a ruler to measure height of wave

y 1.2

ind vary the frequency  
od. Note that

ould be noticeable at this point  
ottom of the tank, or the motor mount