

Modeling the Permittivity of Ferrite-Dielectric Composites

V.A. Astakhov*, R.I. Shakirzyanov, A.T. Morchenko, Z.V. Mingazheva, S.P. Kurochka

National University of Science and Technology, MISiS 4, Leninskiy prosp., 119991 Moscow, Russia

(Received 04 May 2016; published online 03 October 2016)

The paper presents the model of ferrite-dielectric (ferroelectric) composites with semiconductive powder fillers. Such media have the potential for designing systems with controlled frequency dispersion. Experimentally observed significant increase of effective dielectric permittivity in Mn-Zn ferrite composites with the semiconductor pellet is explained on the basis of the capacitance effect. Composites based on Ni-Zn ferrite, which have significantly higher electrical resistance, do not exhibit such phenomena and their behavior is described in the framework of the traditional models of effective medium approximation. There is proposed an analytical solution for the dielectric constant of the composite, based on consideration of the impedances of equivalent circuit involving initial materials (matrix and filler).

Keywords: Electromagnetic radiation, Effective medium approximation, Reflection coefficient, Effective Permeability and Permittivity, Shielding Materials, Ferrite, Composite.

DOI: [10.21272/jnep.8\(3\).03044](https://doi.org/10.21272/jnep.8(3).03044)

PACS numbers: 41.20, 75.40.Gb, 75.471.x, 77.22, 84.40. – x

1. INTRODUCTION

Rapid development in the science and technology in electronics and telecommunication expects finding a solution of electromagnetic radiation (EMR) controlling to provide electromagnetic compatibility of equipment and ecological safety in a wide frequency range [1-3]. The engineering of effective anechoic chambers and shielding systems demands a search of new materials for absorption and shielding of EMR. Compound materials which use polymers as matrix and ferrites as filling phase, can become good alternative to existing materials because of controllable tailoring the spectra of the effective permittivity and permeability [4]. Special urgency to study and modeling of properties of this composites could be explained from prospects for the development of materials which use ferroelectrics as matrix agent. In this case the possibility of control dispersion properties of composite by magnetic or electric fields and implementation of artificial materials with multiferroic properties becomes real. The magnetic composites can be also designed to meet many practical needs by tailoring their effective electromagnetic response [5-7].

Historically the description of composite materials with help of effective magnetic and electric permeability values was made by many authors within a heterogeneous environment models (for example, see works [8-10]). However, in some cases especially in low-frequency range in systems with fillers which have significant conductivity most of them don't give a satisfactory agreement between the experimental data and the effective dielectric permeability ε_{eff} which obtained by the known formulas of mixing of the parameters of the initial components [4] in a low-frequency range (less than 0,5-2 GHz). Above a certain threshold curves of effective permeability which is calculated for all models considered before roughly matched and copied experimental spectra situated between arithmetic and harmonic average from characteristics of the original

components.

For the interpretation of data which was observed in experiments of ε_{eff} we had previously proposed the model of composite by the way of equivalent circuit which represents a system of the parallel and serial connection of capacitors with permittivity ε_1 and ε_2 for the ferrite particles and the matrix, respectively, without taking into account of specific values of the filler particles electroconductivity [11-12].

2. COMPOSITE MODEL

Distinguishing in a volume of composite cube with a side equal D , containing cubic particle of the filler with a edge equal d . In this case volume concentration of the filler in composite is equal $p = (d/D)^3$. So far as material of the injected phase can have significant conductivity, in this work relatively to [4] more general attitude, where magnetic particles represented as capacitors with current leaking, was applied, as shown in Fig. 1.

On the high frequencies of EMR dielectric matrix's materials has reactive (capacitive) conductivity, while filler particles have as reactive (capacitive) as ohmic resistance.

From another point of view, in the assumption of absence of percolation effects all system can be considered as homogeneous entire material, which has capacitive conductivity.

Complex value of effective composite's permittivity can be calculated from expression for whole impedance of system:

$$(Z_{\text{eff}})^{-1} = \left[(Z_{C1}^{-1} + R_1^{-1})^{-1} + 2Z_{C21} \right]^{-1} + Z_{C23}^{-1}, \quad (1)$$

where

$$Z_{\text{eff}} = i / \left(\omega \varepsilon_0 \varepsilon_{\text{eff}} (D+d)^2 / (D+d) \right),$$

$$Z_{C1} = i / \left(\omega \varepsilon_0 \varepsilon_1 D^2 / D \right),$$

* west917@mail.ru

$$R_1 = r_1 (D^* D) / D,$$

$$Z_{C21} = Z_{C22} = i / (\omega \epsilon_0 \epsilon_2 D^2 / (d / 2)),$$

$$Z_{C23} = i / (\omega \epsilon_0 \epsilon_2 (d^* (D+d) + d^* D) / (D+d))$$

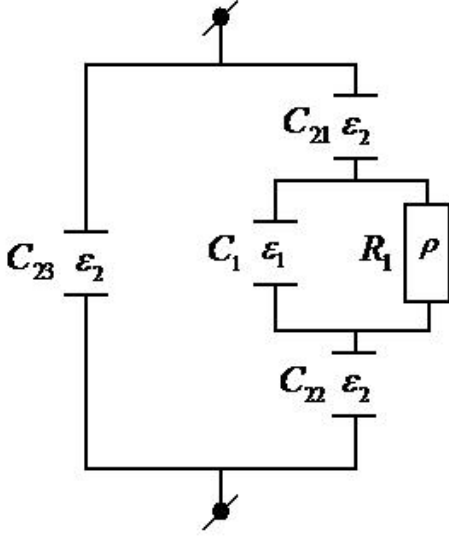

Fig. 1 – Model approximation of elemental composite shell as electric circuit

$$Z_{eff} = i / (\omega \epsilon_0 \epsilon_{eff} (D+d)^2 / (D+d)),$$

$$Z_{C1} = i / (\omega \epsilon_0 \epsilon_1 D^2 / D),$$

$$R_1 = r_1 (D^* D) / D,$$

$$Z_{C21} = Z_{C22} = i / (\omega \epsilon_0 \epsilon_2 D^2 / (d / 2)),$$

$$Z_{C23} = i / (\omega \epsilon_0 \epsilon_2 (d^* (D+d) + d^* D) / (D+d))$$

ω is circular frequency EMR,

i is unit imaginary number.

From (1) we find:

$$\epsilon_{eff} = \epsilon_2 + \epsilon_2 p^{2/3} \left(-\omega^2 r^2 p^{1/3} (\epsilon_1 + \epsilon_2) (\epsilon_1 (1 - p^{1/3}) + \epsilon_2 p^{1/3}) + \right. \\ \left. + i \omega r (\epsilon_2 p^{1/3}) \right) / \left(\omega^2 r^2 (\epsilon_1 (1 - p^{1/3}) - \epsilon_2 p^{1/3}) - \epsilon_1 p^{1/3} \right)^2 + \\ \left. + (1 - p^{1/3})^2 \right) \quad (2)$$

Assuming ϵ_1 and ϵ_2 as complex values and intercepting in (2) real and imaginary parts, it can be obtained:

$$\epsilon'_{eff} = \left[\omega^2 r^2 A + \omega r (B + C) + D \right] / \\ \left[\omega^2 r^2 E + \left((1 - p^{1/3}) + \omega r F \right)^2 \right] \quad (3)$$

$$\epsilon''_{eff} = \left[(1 - p^{1/3}) - \omega r F \right] / \left[\omega^2 r^2 E + \left((1 - p^{1/3}) + \omega r F \right)^2 \right] \quad (4)$$

Here we have used the notation:

$$A = (\epsilon'_1 \epsilon'_2 - \epsilon''_1 \epsilon''_2) (\epsilon'_2 p^{1/3} + \epsilon'_1 (1 - p^{1/3}))$$

$$B = (\epsilon'_1 \epsilon'_2 + \epsilon''_1 \epsilon''_2) (\epsilon'_2 p^{1/3} + \epsilon'_1 (1 - p^{1/3}))$$

$$C = (\epsilon'_1 \epsilon'_2 - \epsilon''_1 \epsilon''_2) (1 - p^{1/3})$$

$$D = (\epsilon'_2 - \epsilon'_1 \epsilon'_2 - \epsilon''_1 \epsilon''_2) (1 - p^{1/3})$$

$$E = \epsilon'_2 p^{1/3} + \epsilon'_1 (1 - p^{1/3})$$

$$F = \epsilon''_2 p^{1/3} + \epsilon''_1 (1 - p^{1/3})$$

Earlier in [4] for description of effect increasing the apparent composite permittivity with high volume concentration of conductive particles, it was suggested to use a equation

$$\epsilon = \epsilon_2 + \Delta \epsilon, \quad (5)$$

where

$$\Delta \epsilon = \epsilon_2 p^{2/3} / (1 - p^{1/3}) \quad (6)$$

This equation qualitatively explained the course of the dispersion curves of the dielectric permittivity spectra on low frequencies. To explain ranges of application estimations of values of critical frequency, from two of the assumptions were investigated. First one was connected with increasing of skin-effect role with growth of EMR frequency. In this occasion process of recharging the particles limited only by surface layer, which made the role of capacitance effect. However estimation of thickness of skin-layer $(2\rho/\mu\omega)^{1/2}$ showed, that thickness of such layer several orders of magnitude higher than sizes of particles.

Second assumption is connected with the time of capacitor recharging. The evaluation of the characteristic frequency where this effect becomes noticeable, can be accomplished by the relaxation time for the formula RC-chain:

$$f_{crit} = 1/\epsilon_0 \epsilon_1 \rho \quad (7)$$

Unfortunately, in literature there are no sufficiently reliable data on resistivity used in experiments for Mn-Zn ferrites (brand 700NM and 2000NM) and their powders, therefore this evaluation was carried out in the range of ρ , given by different manufacturers. From experimental data about frequency dependence of dielectric permittivity according to equation (6) the curve of the critical frequency of the resistivity was built (Fig. 3).

It is easy to see, that on $\rho = 3-7$ Ohm·m effect of increasing of composite's dielectric permittivity should disappear in the range of frequencies 0,5-1,5 GHz, which is similar to experimental data.

In case of using powders of Ni-Zn ferrites (1000NN) which has several orders of magnitude higher resistance (10^5-10^6 Ω·m), critical values placed in interval of MHz frequencies. Therefore, experimental spectra of permittivity of such composites matches to well-known models within the framework of the medium approximation theory.

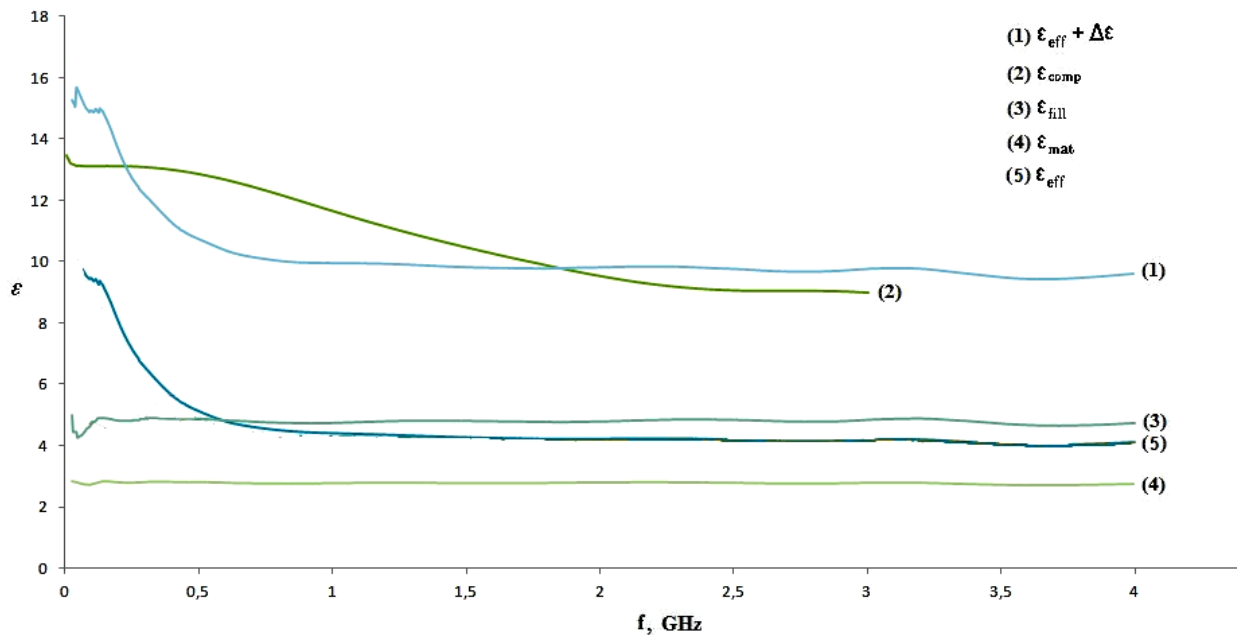

Fig. 2 – Dependence of permittivity on frequency for 1 – model proposed adding values according to the formula (6), 2 – composite sealant + 2000NM ferrite powder with a mass concentration 80 %, 3 – 2000NM ferrite powder, 4 – silicone sealant, 5 – model proposed

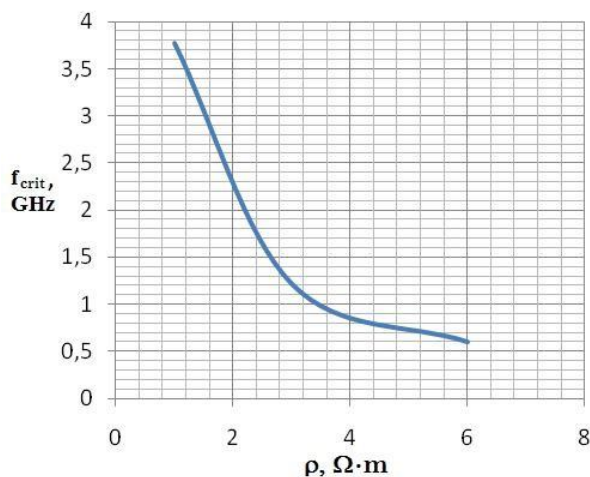

Fig. 3 – The dependence of the critical frequency of the electrical resistivity values typical for ferrites brands 700NM and 2000NM

3. CONCLUSION

Unlike previously considerations the developed model of composites quantitatively takes into account the complex values of the dielectric permittivity of the starting components and the quantitative measure of electrical conductivity (resistivity) of the filler. They are found the contributions of all these material parameters in the real and imaginary parts of effective value of dielectric constant.

REFERENCES

1. C. Tong, *Advanced Materials and Design for Electromagnetic Interference Shielding* (CRC/Taylor & Francis: Boca Raton, FL (2009).
2. Electromagnetic compatibility. EMC standards. IEC 1000-4-6 Conducted RF Immunity; IEC 1000-4-7 Power frequency magnetic; EN 55020 Immunity of broadcast receivers and associated equipment; Electromagnetic compatibility. EMC standards. 300-279 EMC for private land mobile radio and ancillary equipment; 300-329 EMC for DECT cordless phones; 300-339 EMC requirements for radio transmitters; 300-342 EMC for GSM radio phones.
3. R. Kasevich, *IEEE Spectrum* **39**, 15 (2002).
4. A.T. Morchenko, L.V. Panina, S.V. Podgornaya, V.G. Kostishyn, P.A. Ryapolov *J. Nano-Electron. Phys.* **6**, No 3, 03073 (2014).
5. M. Ahmad, F. Aen, M.U. Rana, *Curr. Appl. Phys.* **13**, 41 (2013).
6. M.A. Darwish, S.A. Saafan, D. El-Kony, N.A. Salahuddin, *J. Magn. Magn. Mater.* **385**, 99 (2015).
7. C. Dong, X. Wang, P. Zhou, T. Liu, J.L. Xie, L. Deng, *J. Magn. Magn. Mater.* **354**, 340 (2014).
8. A.P. Vinogradov *Electrodynamics of composite materials Editorial URSS*, 208 (2001).
9. A.N. Lagarkov, L.V. Panina, A.K. Sarychev *ZhTEF* **93**, 215, (1987).
10. V.A. Zlenko, M.H. Demydenko, S.I. Protsenko *J. Nano-Electron. Phys.* **5** No 3, 03055 (2013).
11. M.M. Salem, A.T. Morchenko, L.V. Panina, V.G. Kostishyn, V.G. Andreev, S.B. Bibikov, A.N. Nikolaev *Phys. Procedia* **75**, 1360 (2015)
12. A.T. Morchenko, *Bulletin RAS. Physical series*, **78**, 11, 1481–1490 (2014).