

1401184427

43/445

CRANFIELD INSTITUTE OF TECHNOLOGY

DISTRIBUTION STUDIES UNIT

Ph.D THESIS

Academic Year 1990-1991

Q KHAN

A COMPUTER GRAPHICS APPROACH TO

LOGISTICS STRATEGY MODELLING

Supervisors :

A.S.Rushton

R.J.Saw

November 1990

This thesis is submitted for the degree of Doctor of Philosophy

This work is dedicated:

to My Parents;

and

to those who succeed against all the odds.

Acknowledgement

I thank my mentors Richard Saw and Alan Rushton for providing me the financial and intellectual support for this works to reach to its conclusion. I am also extremely grateful to Ruth and Noreen for their help in the past three years and making the DSU such a fabulous place to work. The help from Wendy and Alex is very much appreciated.

I am also deeply indebted to my parents for sacrificing their pleasure for my future; introducing me to the blessing of knowledge; providing me every thing in their power; waiting for me for so long, and always praying for my success.

I also thanks all my friends who contributed directly or indirectly to this study's reaching its conclusion and particularly Major Mahmoud Gadallah (Egypt), Ibrahim Halil Guzelbey (Turkey), and Anto'nio Brito (Portugal).

Abstract

This thesis describes the development and application of a decision support system for logistics strategy modelling. The decision support system that is developed enables the modelling of logistics systems at a strategic level for any country or area in the world. The model runs on IBM PC or compatible computers under DOS (disk operating system).

The decision support system uses colour graphics to represent the different physical functions of a logistics system. The graphics of the system is machine independent. The model displays on the screen the map of the area or country which is being considered for logistic planning.

The decision support system is hybrid in term of algorithm. It employs optimisation for allocation. The customers are allocated by building a network path from customer to the source points taking into consideration all the production and throughput constraints on factories, distribution depots and transshipment points.

The system uses computer graphic visually interactive heuristics to find the best possible location for distribution depots and transshipment points. In a one depot system it gives the optimum solution but where more than one depot is involved, the optimum solution is not guaranteed.

The developed model is a cost-driven model. It represents all the logistics system costs in their proper form. Its solution very much depends on the relationship between all the costs. The locations of depots and transshipment points depend on the relationship between inbound and outbound transportation costs.

The model has been validated on real world problems, some of which are described here. The advantages of such a decision support system for the formulation of a problem are discussed. Also discussed is the contribution of such an approach at the validation and solution presentation stages.

Content

Chapter One

Introduction

1.0	Introduction	1-1
1.1	Background	1-1
1.2	Objectives of the Work	1-1
1.3	Summary of the work completed	1-2
1.4	Outline of Dissertation	1-2

Chapter Two

Logistics Systems and Structure

2.0	Introduction	2-1
2.1	Logistics System and Structure:	2-1
	2.1.1 Definition	2-1
	2.1.2 Structure Of Logistics System	2-3
	2.1.2.1 Echelon System:	2-7
	2.1.2.2 Direct System	2-11
	2.1.2.3 Flexible System:	2-11
2.2	Logistics System Elements and their Function	2-13
	2.2.1 Product Inventories	2-13
	2.2.2 Transportation and Local Delivery	2-13
	2.2.3 Warehouse/Distribution Depot	2-14
	2.2.4 Communications and Control System	2-15
	2.2.5 Human Resources	2-15
2.3	Logistics System Decision	2-15
	2.3.1 Number and Location of Plants	2-17
	2.3.2 Number and location of Warehouses	2-18
	2.3.3 Modes of Transportation	2-18
	2.3.4 Communications	2-19
2.4	Channels of Distribution	2-19
	2.4.1 Definition of Channel	2-19
	2.4.2 Channel Types and Structure	2-21
	2.4.3 Effects on Logistics Systems	2-23

2.4.4	Just in Time(JIT) and "Pull Systems"	2-23
2.5	Logistics System Cost	2-25
2.5.1	Warehousing cost	2-25
2.5.2	Transport cost	2-25
2.5.2.1	Local delivery cost	2-25
2.5.2.2	Trunking cost	2-26
2.5.3	Inventory cost	2-26
2.5.4	Total Distribution cost	2-26
2.6	Conclusion	2-27

Chapter Three Literature Review

3.0	Introduction	3-1
3.1	Physical Interactive Models	3-1
3.1.1	The Centre of Gravity Method	3-1
3.1.2	Electrical Analogue	3-8
3.1.3	Mechanical Analogue	3-13
3.2	Mathematical Models	3-18
3.2.1	Uncapacitated Simple Facility Location Model	3-19
3.2.2	Uncapacitated Plant and Warehouse Location Model	3-26
3.2.3	Multicommodity Uncapacitated Plant Location Model	3-29
3.2.4	Simple Multistage Plant Location Model	3-31
3.2.5	Capacitated Facility Location Model	3-33
3.2.6	Generalized Capacitated Facility Location Model	3-35
3.2.7	Vehicle Routing and Warehouse Location Model .	3-37
3.2.8	Warehouse Location in Retailing Chain	3-38
3.2.9	Multicommodity Single-Echelon Distribution System Model	3-38

Interactive Modelling

3.3	Introduction	3-41
-----	------------------------	------

3.3.1	The State of Visual Interactive Modelling	3-42
3.4	Applications Of Models	3-49
3.5	Conclusion	3-52

Chapter Four

State of the Art in Computer Graphics and Cartography

4.0	Introduction	4-1
4.1	A Brief History of Computer Graphics	4-1
4.2	Hardware	4-3
4.2.1	Input Devices	4-4
4.2.1.1	Keyboard	4-4
4.2.1.2	Mouse	4-4
4.2.2	Output Devices	4-5
4.2.2.1	Soft Copy Output Devices	4-5
4.2.2.1.1	Video Display Generation	4-5
4.2.2.1.2	Raster-Scan Display	4-6
4.2.2.1.2.1	Frame Buffer	4-7
4.2.2.1.2.2	Display Controller	4-7
4.2.2.1.3	Storage Tube Display	4-7
4.2.2.1.4	Liquid Crystal Display	4-7
4.2.2.2	Hard Copy Output Devices	4-8
4.2.2.2.1	Dot-Matrix Printer	4-8
4.2.2.2.2	Ink-Jet Printer	4-8
4.2.2.2.3	Point Plotters	4-8
4.2.2.2.4	Electrostatic Plotters	4-8
4.3	Software	4-9
4.3.1	Graphics System Software	4-9
4.3.2	Coordinate System	4-11
4.3.2.1	Device Coordinates	4-11
4.3.2.2	Normalized Device Coordinates	4-12
4.3.2.3	World Coordinates	4-12
4.3.3	Viewports	4-14
4.3.4	Transformations	4-14
4.3.5	Clipping	4-16

4.3.5.1	Points Clipping.	4-16
4.3.5.2	Lines Clipping	4-17
4.4	The State of the Art in Cartography	4-17
4.4.1	Shape of the Earth	4-18
4.4.1	Geographical Coordinate	4-18
4.4.2	Latitude and longitude	4-19
4.4.2.1	Latitude	4-19
4.4.2.2	Longitude	4-19
4.4.3	Map Projections:	4-21
4.4.3.1	Angles	4-22
4.4.3.2	Representation of Areas:	4-22
4.4.3.3	Distance	4-22
4.4.3.4	Scale Factor	4-22
4.4.5	The Classification of Projection	4-23
4.4.5.1	Mercator's Projection	4-23
4.4.5.2	Lambert's Projection	4-28
4.4.5.3	Orthographic Projection	4-28
4.5	Problems of Projection for Computer Mapping	4-31
4.6	Programming Language	4-31
4.6	Conclusion	4-32

Chapter Five

State Of the Art in Practical Modelling

5.0	Background	5-1
5.1	Introduction	5-1
5.1.1	Poligami	5-3
5.1.2	Capflo	5-3
5.1.3	Transpart	5-4
5.1.4	Distribution Planner (DISPLAN)	5-5
5.1.5	Logistics Planning System (LPS)	5-7
5.1.6	Distribution Planning System (DiPS)	5-8
5.1.7	Locate II	5-10
5.1.8	Deploy :	5-13
5.1.9	Site	5-14
5.1.10	Distribution Strategy Simulators:(DSS)	5-15

5.2 Spreadsheet Models	5-17
5.3 Conclusion:	5-20

Chapter Six

Approach to model development, how and why

6.0 Introduction	6-1
6.1.1 Optimisation:	6-1
6.1.2 Simulation	6-3
6.1.3 Heuristic	6-5
6.1.4 Comparisons of Operational Research Technique	6-6
6.2 Mainframe Vs Personal Computers	6-11
6.3 Computer Graphics	6-14
6.3.1 Survey of Visually Interactive Models	6-16
6.4 Models for the Nineties	6-21
6.5 Conclusion	6-23

Chapter Seven

Description of the Model

7.0 Introduction	7-1
7.1 Model Development Approach	7-1
7.2 Map Display	7-8
7.3 Distance Calculation	7-10
7.3.1 The Great Circle Formula	7-10
7.4 Barrier Calculation	7-13
7.5 Hazard Calculation	7-16
7.6 Allocation	7-18
7.7 Local Delivery Cost	7-20
7.8 Trunking Cost	7-25
7.9 Warehouse Cost	7-29
7.10 Inventory Cost:	7-30
7.10.1 Stock Replenishment	7-31
7.11 Depot Delivery Area:	7-35
7.12 Forecasting	7-38
7.13 Search for best Location:	7-39

7.14	Modification	7-41
7.15	Zooming	7-42
7.16	Conclusion	7-44

Chapter Eight

Model Structure

8.0	Introduction	8-1
8.1	Model Overview	8-1
8.2	Database File Structure	8-6
8.2.1	Map Database File	8-6
8.2.1.1	Elements of Map File	8-6
8.2.2	Factory Database File	8-8
8.2.2.1	Elements of Factory File	8-8
8.2.3	Depot Database File	8-9
8.2.3.1	Elements of Depot File	8-9
8.2.4	Customer Database File	8-10
8.2.4.1	Customer File Elements	8-10
8.2.5	Cost database File and its Elements	8-10
8.2.6	Hazard Database File	8-12
8.2.6.1	Hazard File Elements	8-12
8.2.7	Barrier Database File	8-12
8.2.7.1	Barrier File Elements	8-12
8.3	Aallocation	8-13
8.3.1	Readca	8-15
8.3.2	Cusort	8-15
8.3.3	Alocat	8-18
8.3.4	Alo1	8-18
8.3.5	Hazard	8-22
8.3.6	Brdeld	8-22
8.3.7	Cusf	8-22
8.3.8	Trad	8-32
8.3.9	Alo2	8-32
8.3.10	Al1	8-32
8.3.11	Twalo	8-32
8.3.12	Tw1	8-37

8.3.13 Tw2	8-37
8.3.14 Pdalo	8-37
8.3.15 Pd1	8-37
8.3.16 Pd2	8-42
8.4 Costs	8-42
8.4.1 Incos	8-42
8.4.2 Lodeco	8-42
8.4.3 Trdeco	8-42
8.4.4 Aloc1	8-47
8.5 Optimisation	8-47
8.5.1 Autloc	8-47
8.5.2 Autlo	8-52
8.6 Modify	8-52
8.6.1 cnpl	8-52
8.6.2 Cnpl2	8-58
8.6.3 Cnpl3	8-58
8.6.4 Focast	8-58
8.6.5 Focast1	8-67
8.6.6 Focast2	8-67
8.7 Man1	8-70
8.7.1 Manal1	8-70
8.8 Alo6	8-78
8.8.1 Pdetail	8-78
8.8.2 Ddetail	8-78
8.9 Zooming	8-78
8.10 Prints	8-92
8.11 Conclusion	8-92

Chapter Nine

Validation of Model

9.0 Introduction	9-1
9.1 Case Study A	
9.1.0 Introduction	9-2
9.1.1 Background	9-3
9.1.2 Objectives:	9-4

9.1.3	Approach	9-4
9.1.4	Stage II Options Identification	9-6
9.1.4.1	Physical Handling Facility Survey (PHFS)	9-9
9.1.4.2	West European Chemical Industry Survey	9-10
9.1.5	The Major Options	9-11
9.1.5.1	Short List of Options	9-12
9.1.6	Using LSM	9-12
9.1.6.1	Validation	9-16
9.1.6.2	1992 Model Runs	9-18
9.1.6.3	Existing Policy	9-18
9.1.6.4	7 Container Depots	9-18
9.1.6.5	7 Container Depots (Optimised Locations)	9-19
9.1.6.6	Sensitivity Analysis on Depots	9-20
9.1.6.7	Hub Depot	9-20
9.1.7	1992 Options	9-23
9.1.7.1	Option 1	9-23
9.1.7.2	Option 2	9-23
9.1.7.3	Option 3	9-24
9.1.8	Conclusion	9-24
9.2	Case Study B	
9.2.0	Introduction	9-26
9.2.1	Background	9-27
9.2.2	Terms of Reference:	9-27
9.2.3	Approach:	9-28
9.2.3	Using LSM	9-28
9.2.3.1	Data Collection	9-29
9.2.3.2	Validation of Model	9-29
9.2.4	Integrated Approach:	9-31
9.2.4.1	Central Depot Option	9-31
9.2.4.2	Two Depots Option	9-34
9.2.4.3	Three Depots Option	9-38
9.2.4.4	Summary :	9-42
9.2.5	1992 Options	9-42
9.2.5.1	Central Depot Options	9-46
9.2.5.2	Two Depots Options	9-46

9.2.5.3	Three depots Options	9-52
9.2.6	Other alternative:	9-58
9.2.7	Conclusion	9-58
9.3	Case Study C	
9.3.1	Background	9-65
9.3.2	Objective	9-65
9.3.3	Source Points (Factory)	9-65
9.3.4	Demand Points	9-66
9.3.5	Distribution Strategy	9-66
9.3.6	Conclusion	9-70
9.4	Conclusion & Summary	9-84

Chapter Ten

Model's Review

10.0	Introduction	10-1
10.1	Critical analysis	10-1
10.2	Drawbacks	10-1
10.3	Further Research	10-2
10.4	Conclusion	10-3

Chapter Eleven

Conclusion

11.0	Introduction	11-1
11.1	Summary of Work Undertaken	11-1
11.2	Overall Conclusions	11-4
11.3	Research Contribution	11-6

References	R-1
-------------------------	------------

Appendix A	A-1
-------------------------	------------

User Document	U-1
----------------------------	------------

Figures

Figures No	Names	Page number
2.1	Logistics System Structure	2-4
2.2	Logistics System Structure	2-5
2.3	Logistics System Structure	2-6
2.4	Logistics System Structure	2-8
2.5	Logistics System Structure	2-9
2.6	Logistics System Structure	2-10
2.7	Logistics System Structure	2-12
2.8	Alternative Distribution Channels	2-22
2.9	Total Distribution Cost Vs Number of Depots	2-27
3.1	Central Gravity Illustration	3-2
3.2	Error in Gravity Method Vs Number of Points	3-6
3.3	Error in Gravity Method Vs Number of Points	3-7
3.4	Electric Analogue	3-11
3.5	Electric Analogue	3-12
3.6	Mechanical Analogue	3-16
3.7	Mechanical Analogue	3-17
4.1	Computer Graphics System Cost Vs Time	4-3
4.2	Device Coordinates	4-11
4.3	Normalized Device Coordinates	4-13
4.4	World Coordinates	4-13
4.5	Viewports	4-14
4.6	Parallels of Latitude	4-20
4.7	The Meridians of Longitude	4-20
4.8	The Development Surface to which the Development Surface may be Projected	4-24
4.9	The Bonne Projection	4-25
4.10	The Hammer Projection	4-26
4.11	The Mercator Projection	4-27
4.12	The Lambert Projection	4-29
4.13	The Orthographic Projection	4-30
6.1	The Number of Models Vs Technique Used	6-10

7.1	Logistics Strategy Model Structure	7-7
7.2	LSM Working Structure	7-8
8.1	LSM Over View Structure	8-7
8.2	Map Database File	8-8
8.3	Factory Database File	8-8
8.4	Depot Database File	8-9
8.5	Customer Database File	8-10
8.6	Cost Database File	8-11
8.7	Hazard Database File	8-12
8.8	Barrier Database File	8-13
8.9	Reading File Structure	8-14
8.10	Subroutine Readca	8-16
8.11	Subroutine Cusort	8-17
8.12	Subroutine Alocat	8-19
8.13	Subroutine Alo1	8-20
8.14	Subroutine Alo1	8-21
8.15	Subroutine Hazard	8-23
8.15a	Subroutine Hazard	8-24
8.15b	Subroutine Hazard	8-25
8.16a	Subroutine Barrier	8-26
8.16b	Subroutine Barrier	8-27
8.16c	Subroutine Barrier	8-28
8.16d	Subroutine Barrier	8-29
8.16e	Subroutine Barrier	8-30
8.17	Subroutine Cusf	8-31
8.18	Subroutine Trad	8-33
8.19	Subroutine Alo2	8-34
8.20	Subroutine All	8-35
8.21	Subroutine Twalo	8-36
8.22	Subroutine Tw1	8-38
8.23	Subroutine Tw2	8-39
8.24	Subroutine Pdalo	8-40
8.25	Subroutine Pd1	8-41
8.26	Subroutine Pd2	8-43
8.27	Subroutine Incos	8-44
8.28	Subroutine Lodeco	8-45

8.29	Subroutine Trdeco	8-46
8.30	Subroutine Aloc1	8-48
8.31	Subroutine Autloc	8-49
8.31a	Subroutine Autloc	8-50
8.31b	Subroutine Autloc	8-51
8.32	Subroutine Autlo	8-53
8.32a	Subroutine Autlo	8-54
8.32b	Subroutine Autlo	8-55
8.33	Subroutine Modify	8-56
8.34	Subroutine Cnpl	8-57
8.34a	Subroutine Cnpl2	8-59
8.34b	Subroutine Cnpl3	8-60
8.35	Subroutine Cndis	8-61
8.35a	Subroutine Cndis2	8-62
8.35b	Subroutine Cndis3	8-63
8.36	Subroutine Ccnu	8-64
8.36a	Subroutine Ccnu2	8-65
8.36b	Subroutine Ccnu3	8-66
8.37	Subroutine Focast	8-68
8.37a	Subroutine Focast1	8-69
8.37b	Subroutine Focast2	8-71
8.38	Subroutine Man1	8-72
8.38a	Subroutine Manal1	8-73
8.38b	Subroutine Manal1	8-74
8.38c	Subroutine Manal2	8-75
8.38d	Subroutine Manal2	8-76
8.38e	Subroutine Manal3	8-77
8.38f	Subroutine Manal3	8-79
8.39	Subroutine Alo6	8-80
8.40	Subroutine Pdetail	8-81
8.40a	Subroutine Pdetail	8-82
8.41	Subroutine Ddetail	8-83
8.41a	Subroutine Ddetail	8-84
8.41b	Subroutine Ddetail	8-85
8.41c	Subroutine Ddetail	8-86
8.41d	Subroutine Ddetail	8-87

8.41e	Subroutine Ddetail	8-88
8.42	Subroutine Zooming	8-89
8.42a	Subroutine Zooming	8-90
8.42b	Subroutine Zooming	8-91
8.43	Subroutine Prints	8-92
9.1a	Number of Option for Each Area	9-7
9.2a	Source and Demand Points	9-13
9.3a	Production Versa Plants	9-14
9.4a	Total Amount Transported to Each Country	9-15
9.5a	Number of Depot Vs Total Cost	9-21
9.6a	Number of Depot Vs Cost/MT	9-22
9.1b	Validation Chart for Division A	9-29
9.2b	Validation Chart for Division B	9-30
9.3b	Validation Chart for Division C	9-30
9.4b	Validation Chart for Division C	9-31
9.5b	Source and Demand Points for 1988	9-32
9.6b	Source and Demand Points for Direct Delivery 1988	9-33
9.7b	Central Depot Option	9-35
9.8b	Central Depot and Scottish Transshipment Point	9-36
9.9b	Central Depot and Scottish & Bristol Transshipment Points	9-37
9.10b	Two Depots Option	9-39
9.11b	Two Depots and Scottish Transshipment Point	9-40
9.12b	Two Depots and Scottish & Bristol Transshipment Points	9-41
9.13b	Three Depots Options	9-43
9.14b	Total Cost Vs Number of Depots	9-44
9.15b	Number of Depots Vs Cost	9-45
9.16b	Expected Demand Increase for 1992	9-46
9.17b	Source & Demand Points for 1992	9-47
9.18b	Source & Demand Points for 1992 (direct delivery)	9-48
9.19b	Central Depot (best possible location)	9-49
9.20b	Central Depot and Scottish & Bristol transshipment points (best possible location)	9-50

9.21b	Two Depots (best possible location)	9-51
9.22b	Two Depots (best possible location) Scottish Transshipment Point	9-53
9.23b	Two Depots (optimised) (best possible location) Scottish & Bristol Transshipment Points	9-54
9.24b	Two Depots Scottish & Bristol Transshipment Points (best possible location)	9-55
9.25b	Three Depots Options (best possible location)	9-56
9.26b	Three Depots Options (best possible location) Bristol Transshipment Point	9-57
9.27b	Three Depots Bristol Transshipment Point (best possible location)	9-59
9.28b	Two depots Scottish & Bristol Transshipment Points	9-60
9.29b	Cost Breakdown all Options 1992	9-61
9.30b	Total Weekly Cost for 1992	9-62
9.31b	Cost Breakdown all Options 1992	9-63
9.1c	Source and Market Area	9-67
9.2c	One Depots Option	9-68
9.3c	Two Depots Option	9-69
9.4c	Three Depots Option	9-71
9.5c	Four Depots Option	9-72
9.6c	Five Depots Option	9-73
9.7c	Six Depots Option	9-74
9.8c	Seven Depots Option	9-75
9.9c	Eight Depots Option	9-76
9.10c	Nine Depots Option	9-77
9.11c	Number of Depots Vs Local Delivery Cost	9-78
9.12c	Number of Depots Vs Total Trunking Cost	9-79
9.13c	Number of Depots Vs Depot Cost	9-80
9.14c	Number of Depots Vs Inventory Cost	9-81
9.15c	Number of Depots Vs Total Cost	9-82
9.16c	Number of Depots Vs Individual Cost	9-83

U1	Screen Output	U-3
U2	Depot not be Optimise	U-4
U3	Optimisation Depot Screen	U-6
U4	Modification Screen	U-7
U5	Modification Screen	U-9
U6	Saving File Facility	U-11
U7	Forecasting Output	U-17
U8	Forecasting Windows on the Screen	U-18
U9	Manual Allocation	U-23
U10	Highlight the Customer	U-24
U11	Highlight the Depot	U-25
U12	Allocation Line and Cost	U-27

Tables

5.1	Displan Applications	5-6
7.1	Change of Value of Cosine with Degree	7-11
7.2	Length of one Degree of Longitude	7-12
9.1a	Model validation for Case Study A	9-17
9.2a	Percentage increase from each plant to a country for 1992	9-19

Glossary of Terms

- Barrier** A barrier is a line within the confines of the modelling area such that a journey is unable to pass through that line, but must go around it. A barrier might be a river, some sea, mountains etc.
- Customer** A customer is the final delivery point for products and the point at which no further distribution costs are taken into consideration.
- Depot** A depot is any site from which products are distributed to customers. There are two types of depot: distribution depots and transshipment points.
- Distribution Depot** A distribution depot is any depot that distributes products to customers and receives products directly from factory and has the ability to hold the Inventory stock. It is also known as a warehouse in this dissertation.
- Factory** A factory is any site at which products are manufactured and from where they are transported to depots for distribution to customers. A factory may also be used to represent a point of importation into an area such as a sea port at which the goods arrive.
- Hazard** A hazard is an area within the confines of the modelling area that, when a journey is caused to pass through that area, the journey is caused to increase in distance according to the penalty factor for that hazard.
- Product** A product is the subdivision of a product range or product group for production and distribution purposes.

Product Group A product group is a number of similar products which can be treated in the same way for the purposes of distribution strategy modelling.

Transshipment Point:

A transshipment point is a point that enables the distribution of products to customers and that receives products directly from distribution depots. It has no facility to hold inventory.

Chapter One

Introduction

1.0 Introduction

In this chapter the background, objectives and outline of the dissertation will be discussed.

1.1 Background

A recent survey of 380 manufacturing companies in the U.S.A established that over 25 % of the respondents planned to increase their logistical modelling applications, [Bowersox 1987]. As the number of companies are increasingly using logistic models, the search for a prototype, user friendly and reasonable cost model increases. User friendly because another survey on the development and use of mathematical models by the National Science Foundation [Fromm et al 1974] concluded that *Seventy five percent of these models could only be operated by the original development team*. Furthermore, despite strong efforts in model and program documentation, actual policy use of these models other than by the original designer has been minimal.

1.2 Objectives of the Work

The main objective of this thesis is to develop a visually interactive prototype decision support system for logistics system modelling. The system is intended to be sufficiently flexible to model any part of the world. It should be able to utilise high resolution computer graphics technology and optimisation in screen display. The system should be able to run on a personal computer (PC) under disk operating system (DOS) and when new operating systems are available it should be able to run under these.

The personal computer is used to make the model available for small companies which otherwise may not be able to benefit from the combined use of operational research, computer graphics and information technology. In the age of portable computers the model should also be portable and should be useable in any part of the world.

The system should be able to model real world problems. The model should be able to handle realistic logistics and distribution networks and adequate number of customers, depots and factories.

This decision support system should be used by managers who would like to test various options for their distribution system. The model should optimise for allocating the market area to the distribution depot taking into consideration the network cost from factory to market area. For the movement of depots it should use heuristics to find the best possible location, therefore the model algorithm should be classified as a hybrid.

1.3 Summary of the work completed

The Logistics Strategy Model (LSM) that has been developed is able to model one thousand customers, fifty distribution depots or transshipment points, ten factories and ten different products. The system is based on visually interactive graphics. It communicates with users through the screen by using the arrow keyboard and mouse. The interactive procedure is used during all processes such as drawing the boundary lines between the depot, showing the intensity flow of the demand from factory to depot and between depot to transshipment points. All "what if" strategy can be designed by visual interactive means. The modeller is able to modify the number of depot, customer and source points on the screen by using arrow keys. The developed model also visually displays the movement of depots during the search for the best location place in the serving area.

1.4 Outline of Dissertation

This dissertation describes the development of a visual interactive graphics decision support system to assist the logistician in strategic planning for distribution systems. The model could also be used for other facilities location problems such as post office, hospital, police station and fire station.

In chapter two logistics systems and their structure and logistics system

elements and their functions are discussed. The decisions involved in the design of a logistics system are described. The details of different logistics channels are also given in this chapter. The different costs of a logistics system and their interrelationship and their effect on total cost are fully described.

Chapter three describes the state of the art in modelling techniques for distribution and logistics. It covers physical interactive models, mathematical models, visually interactive models and the application of models to solve real world problems.

Chapter four reviews the state of the art in computer graphics, software, hardware, and input and output devices. It also describes the state of the art in cartography as it relates to computer map representation. The graphics package HALO and programming language Fortran which are used to develop the LSM are also described in this chapter.

Current developments in distribution modelling are discussed in chapter five. The purpose built models and spreadsheet models which are being used at present in the logistics industry and in the academic environment are described.

In chapter six operations research techniques such as optimisation, simulation and heuristics are described, their advantages and disadvantages are explored. The reason for adopting the hybrid modelling approach for LSM are given. The results of a survey is provided, comparing the visual interactive model with noninteractive models and gives a detailed account of visual interactive model use.

Chapter seven describes the model that has been developed, covering the major modelling aspects, the algorithms, allocation procedures, trunking cost,

local delivery cost, warehouse cost, inventory cost, extra distance calculation for hazards and barriers. It also describes the procedures for drawing the maps and boundary between the depots. This chapter provides a detailed account for best possible location search for a depot and different demands forecasting options.

Chapter eight describes the basic files required to run the system. It gives examples and particular formats for each file which is used to run the LSM. It also provides a comprehensive detailed account for each subroutine, its flow charts and how each subroutine works and its contribution in LSM.

In chapter nine the model validation is described. This includes the application of the (LSM) to some real world case studies some problems are highlighted and particular features of each case study are presented. The LSM special features which helped to design the presented solutions in a specific form are described.

Chapter ten provides a critique of the model, describing some of its drawbacks. An indication of area for future works and further development are discussed.

Chapter eleven summarise the major features of the work undertaken and draws the final conclusions. The original aspects of the work are also discussed.

Chapter Two

Logistics Systems and Structures

2.0 Introduction

In this chapter different factors related to logistics systems and functions are discussed. These include, the different definitions of logistics system structure, logistics system elements and their functions. Also described are the decisions involved in designing a logistics system, different channels of distribution and logistics systems. Finally the different costs of a logistics system, the inter-relationship and effects on total system cost are described.

2.1 Logistics System and Structure

In this section the different definitions of a logistics system and its structure are discussed.

2.1.1 Definition

A logistics system has been defined in different text books and academic journals, some of the definitions are as follows:

" A logistics systems contains many interactive elements, and includes activities whose performance is affected by time lags; its elements are affected by randomness and unpredictability, employ information and data, embody component and organisation. "

[Geisler et al 1963]

"The logistics system of a firm includes the total flow of materials, from the acquisition of raw materials to the delivery of the finished product to the ultimate user. "

[Magee 1967]

" A physical distribution system embraces all of the physical handling required between the point of production and the point of consumption of a

given material or product."

[Saunders 1969].

"A physical distribution system consists of several interactive activity centres or subsystems among which trade-offs in cost, service, and flexibility exist. These sub-systems are often referred to as components of the physical distribution system."

[Bowersox et al 1971]

" A logistics system is the logical conceptual arrangement of the functional areas of an operation which moves goods, or information from one location to another. The system includes all movement from the shipment of the raw materials to the final resting points of the end products."

[Mossman et al 1977]

"Logistics system may consist of trunk vehicles, warehouses, delivery vehicles, maintenance workshop and human resources."

[Davis 1977]

" A physical distribution system could be characterised as the function which relates to the efficient propulsion of goods flow between producers and customer in a such a way that goods reach a customers in the right place and at the right time with right cost."

[Pools van Amstel 1987]

These are some of the definitions which are described in the literature. The interesting aspect to observe is how they have developed with time. The different components of interaction have been recognised and important factors such as cost efficiency is also included in later definitions. Therefore the logistics system for this dissertation is defined as follows;

" The function which moves goods efficiently and effectively from production plants to market areas and customers location."

2.1.2 Structure Of Logistics System.

Logistics system structures can and do differ quite dramatically between one company and another, and one industry and another. The logistics system structure usually consists of the structural design, planning, performance and control of all transportation, handling, storing and packaging procedures and these facilitate the flow of the product from suppliers to the customer, including the related flow of information.

Rushton defines the structure of a physical logistics system as the:-

" Flow of material or product, interspersed at various points by stationary intervals. This flow is usually indicated by some form of transportation of the product. The stationary periods are usually for storage, or to allow some change to the product to take place ,manufacture, assembly, packing, break bulk, etc. Also the cost and flow of information related with above operations."

[Rushton et al 1989]

They also illustrated their defined structure graphically which is depicted in Figure 2.1. Their structure considers the movement of material from originator (supplier to raw material supplier) to the end user, this structure has recently been known as a "total supply chain ".

Waller describing the DSS (Distribution Strategy Simulator), defined the distribution system structure which is shown in Figure 2.2 [Waller 1987]. This structure considers the movement of goods between the factory and from factory direct to customer and also from factory through a network to the customers.

Eilon defines the logistics system structure which is depicted in Figure 2.3

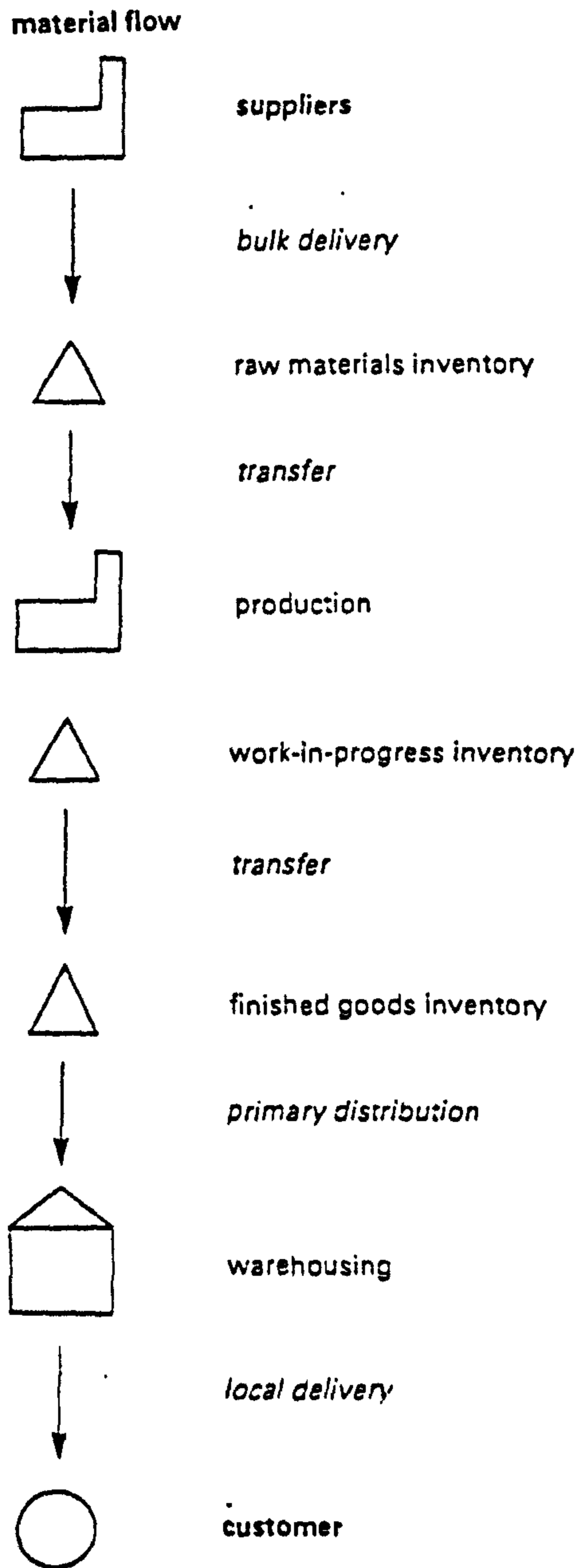

Figure 2.1

Logistics system structure (Source Rushton et al 1989)

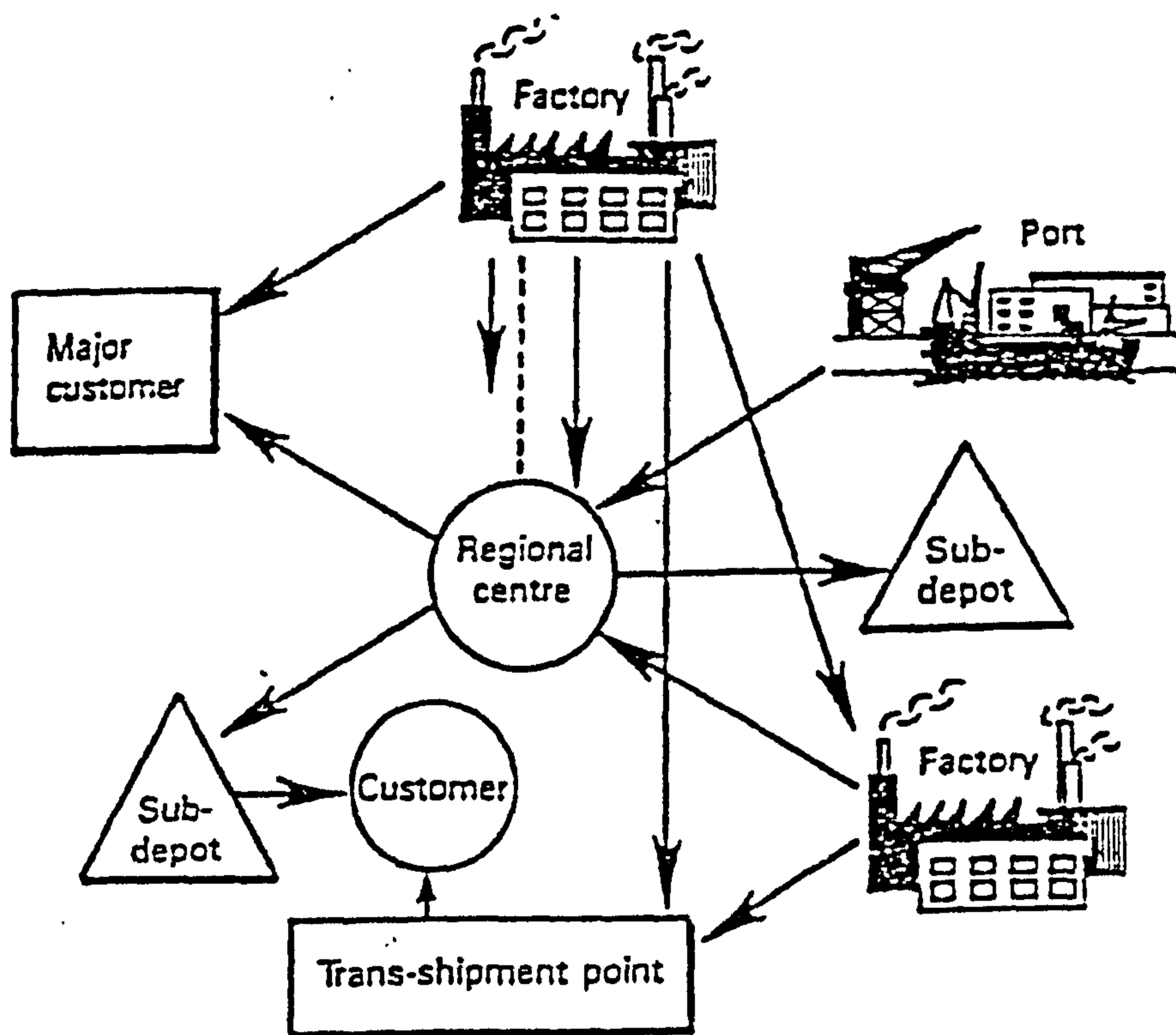

Figure 2.2

Logistics system structure (Source Waller 1987)

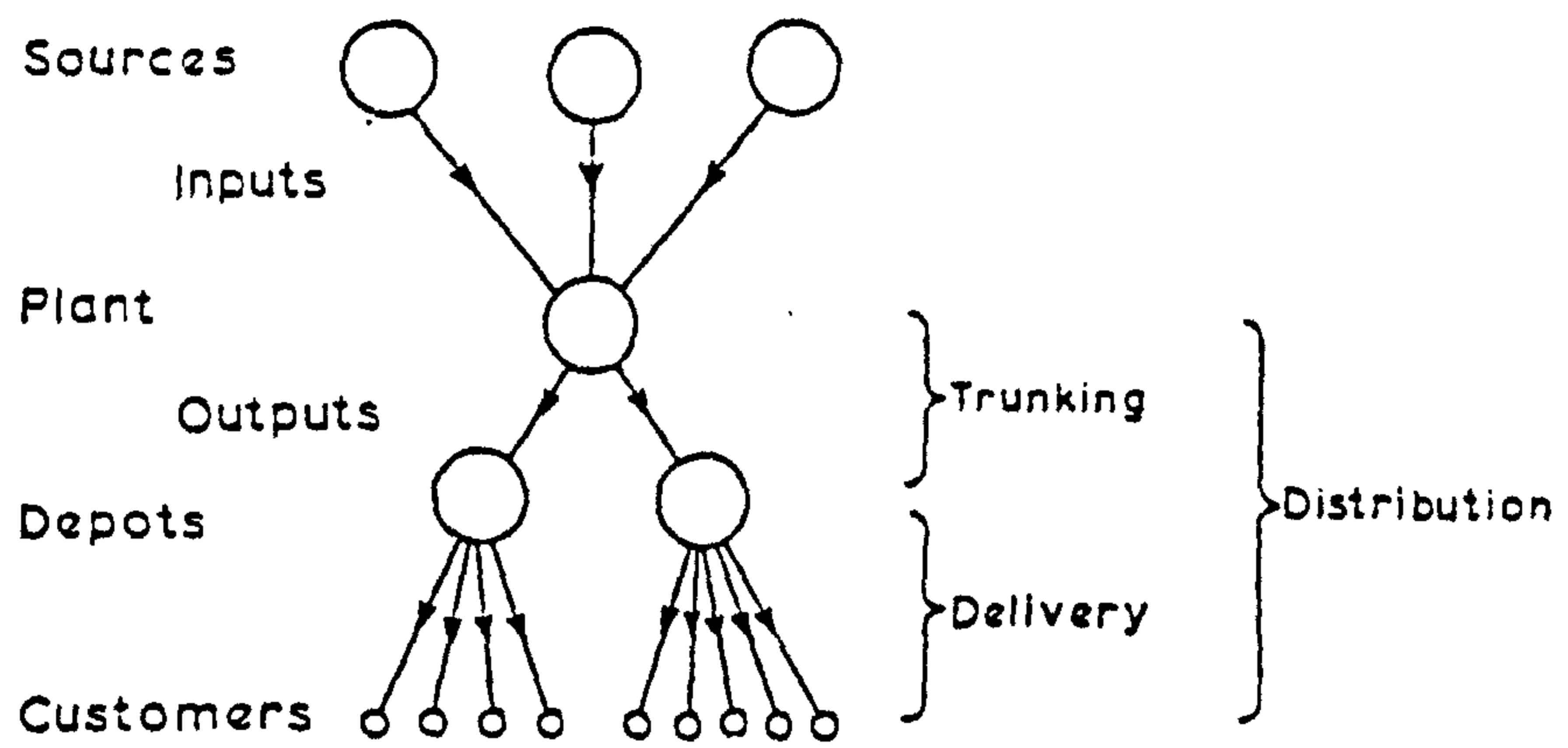

Figure 2.3

Logistics system structure (Source Eilon et al 1971)

[Eilon et al 1971]. This structure considers the distribution from factory to depot to customers. It does not consider the raw materials or production process at the factory.

The product flow network and the information network combines to form a conceptualised logistics system structure, which is depicted in Figure 2.4 [Ballou 1970]. This structure also includes the information flow and interflow between the facility system structure.

Davis considered the logistics system structure as a distribution chain which is shown graphically in Figure 2.5 [Davis 1977]. In this structure it considers the movement of material from the material suppliers warehouse to retail branch outlet. It does not include the information flow and product inter flow between the facility.

Pools van Amstel's logistics system structure is depicted in Figure 2.6 [Pools van Amstel 1987]. It considered physical distribution from finished stock at manufacturing plants to the retail stores.

Bowersox [Bowersox 1978] divided the logistics structure into three possible categories, (a) echelon system structure, (b) direct system structure (c) flexible system structure. These are now explained;

2.1.2.1 Echelon System

The term echelon implies that the flow of products or material proceeds through a series of consecutive locations as it moves from origin to final destination. Such steps involve the accumulation of inventory in warehouses. Thus the essential characteristic of an echelon system is that inventory is stocked at one or more points prior to arrival at its final destination.

Two common echelon patterns are the establishment of break bulk and consolidation warehouses in physical distribution systems. The break-bulk

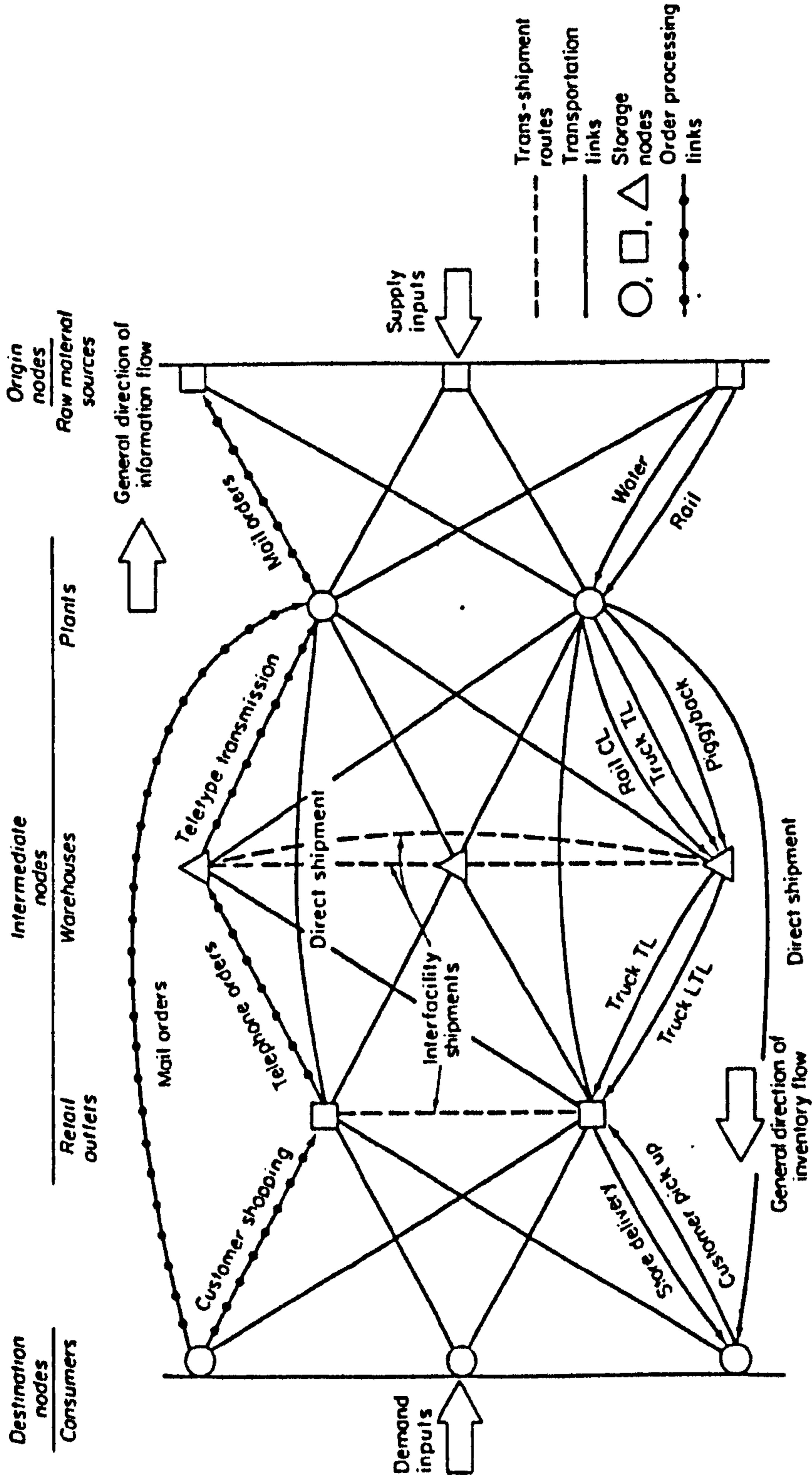

Figure 2.4 Logistics system structure (Source Ballou 1970)

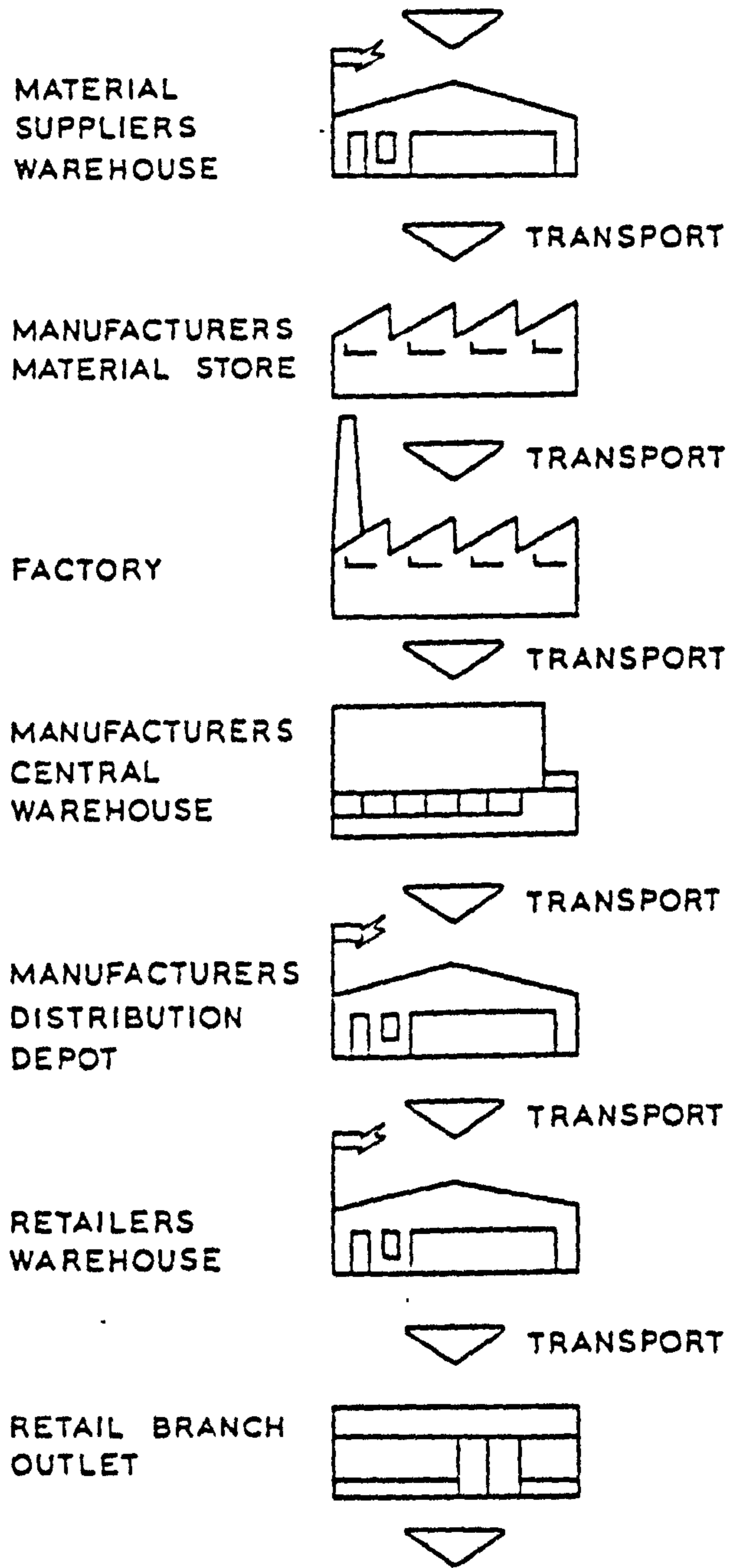

Figure 2.5

Logistics system structure (Source Davis 1977)

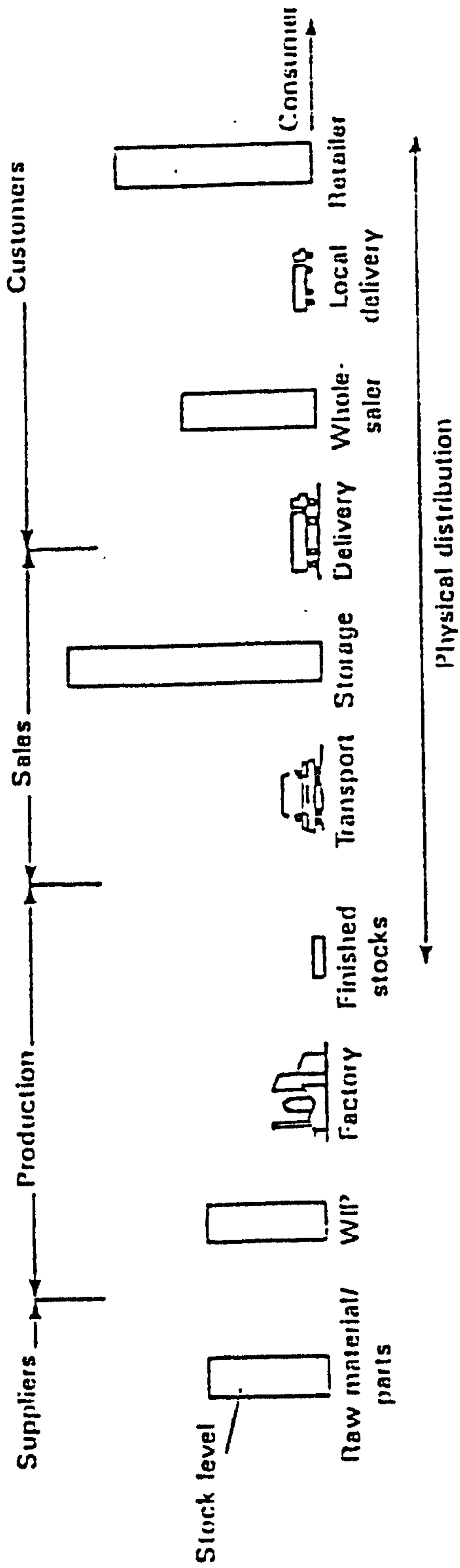

Figure 2.6 Logistics system structure (Source Amste I 1987)

warehouse receives large volume shipments from a variety of suppliers for sortation into combinations required for individual customers or retailers.

The consolidation distribution warehouse is normally operated by an enterprise that produces product lines at different production plants. Consolidation of all products at a central point makes it possible to ship large volumes of the completed products together. Echelon system structure is shown in figure 2.7 [Bowersox 1972].

2.1.2.2 Direct System:

Contrasting with the echelon pattern structure are systems structures operating direct to final destination from one or a limited number of central inventory accumulations. Direct-distribution enterprises find that their particular marketing efforts can be best supported by a central inventory from which customers orders are filled. Direct-product-distribution often utilizes the high-speed transport and electronic order processing to overcome geographical separation from customers. Direct system structure is depicted in figure 2.7 Bowersox [1972].

2.1.2.3 Flexible System:

The most common logistical systems are those combining the principles of the echelon and direct systems into a flexible operating pattern. Inventory selectivity is encouraged in the design of such logistical systems. Some products or materials may be held in warehouses, others may be distributed directly. In many cases, the nature, composition, or order size may determine the location from which a customer will be serviced.

For example, one enterprise supplies after-market replacement automobile parts to support its new-car distribution. Its system is designed to hold warehouse inventories at various distances from prime markets. The slower the part turnover the more centralised the inventory. The slowest moving parts are held at the central location, which directly supplies the entire world.

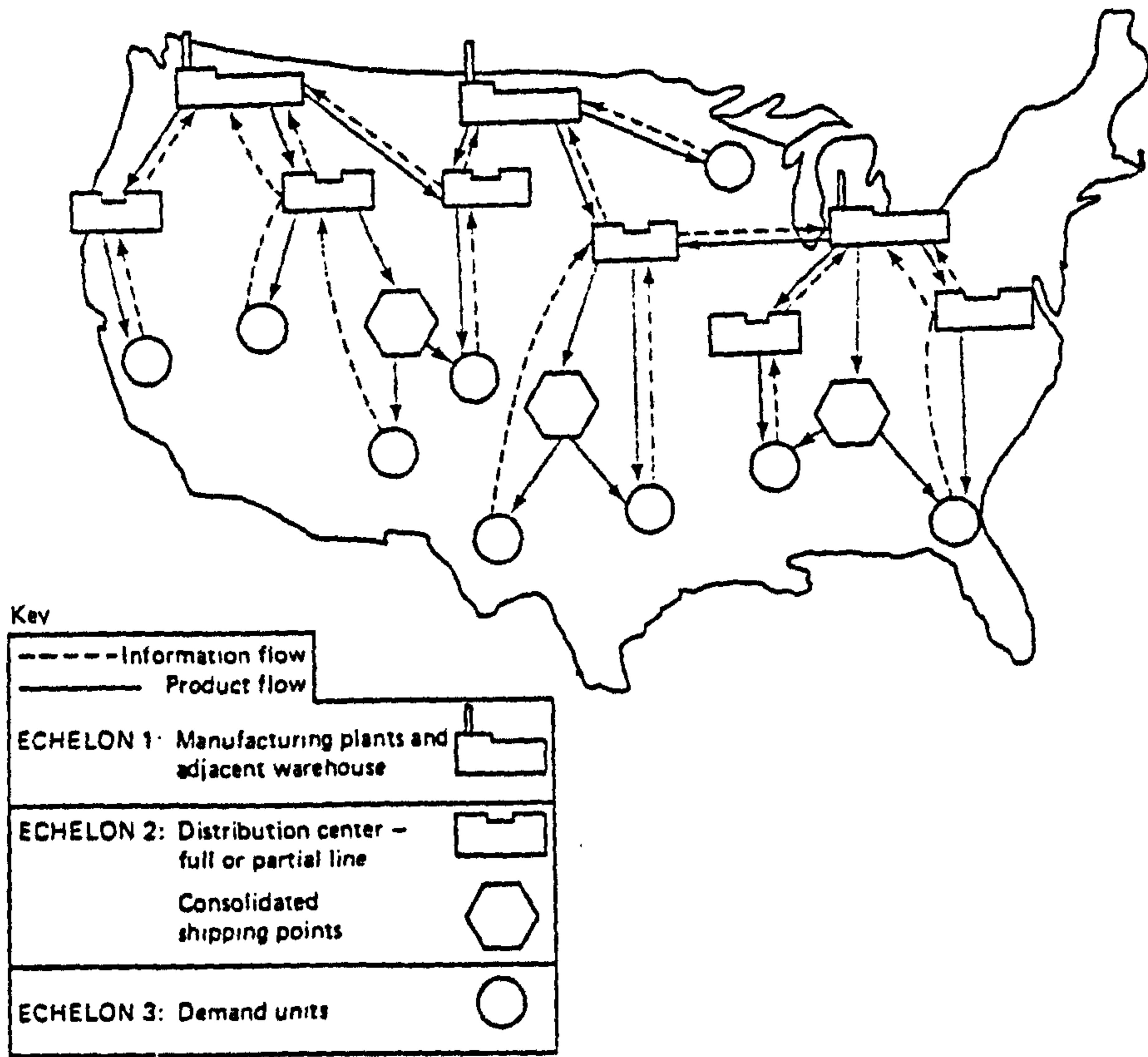

Figure 2.7

Logistics system structure (Source Bowersox 1978)

A second enterprise, which supplies industrial replacement parts, follows a completely opposite distribution policy. In order to rapidly meet unexpected demands, this enterprise holds inventory of sufficient quantities of all slow movers at each distribution warehouse.

From the above discussion the overall logistics structure may be defined as :-

" The movement of goods and information from production plants to the distribution depots and to the customers and also from factory to distribution depot to the transshipment points to the customers ."

2.2 Logistics System Elements and their Function.

The major logistics system elements include inventories, transportation, warehousing, communications and control systems and human resources.

2.2.1 Product Inventories

Inventories are carried as a buffer between transportation, manufacturing, and processing operations to permit economical and effective system operations. Products may be stored where they are made and also at various points in the field, that is, closer to the consumer. Products in storage are not dead or inactive, but are critical to the effective operation of the system. Products in storage permit the system to accommodate unexpected or chance variations in demand or output at any point. Products in storage also permit an individual manufacturing or transportation activity to operate on a time cycle or with quantities of the product adapted to its particular characteristics, with less need for the activity to accommodate its operations to the requirements of proceeding or following activities.

2.2.2 Transportation and Local Delivery

Transportation includes from factory to distribution centre ,from distribution centre to transshipment point, from transshipment point to customer and also

from distribution depot to customers and from factory to customers. In most cases goods are delivered from factory to distribution depot in bulk or trunked and from distribution depot to customer is delivered in small orders. If this perception is correct, the cost of local delivery is higher than trunking delivery. The important aspect to consider is the trunking versus local delivery and the type of vehicle which is used in each case.

2.2.3 Warehouse/Distribution Depot

Warehouses may be factory warehouses, regional warehouses, local warehouses and field warehouses.

Warehouse Function:

Rushton defines the following function for a warehouse [Rushton et al 1989]:

Goods in

- ◆ Receipt - unload, temporary hold;
- ◆ Check - correct goods received, grade, package,
- quantity, quality, damage or shortages;
- ◆ Record receipts and discrepancies;
- ◆ Unpack, repack if necessary;
- ◆ Decide where goods are to be located.

Main store - reserve stock

- ◆ Locate goods in reserve storage area;
- ◆ Confirm goods location to control function;
- ◆ Issue goods to replenish order picking stock.

Order picking - forward stock

- ◆ Select goods from order picking stock to meet customer orders;
- ◆ Pack and check;
- ◆ Packaging material store.

Marshalling

- ◆ Assemble goods by customer, or by vehicle load.

Goods out

- ◆ Load - loading facilities for vehicles;
- ◆ Despatch - vehicle schedules.

2.2.4 Communications and Control System

Any logistics system is managed by an intricate communications and control subsystem. This subsystem processes orders from purchaser or user to supplier as well as instructions to move or ship materials. It also maintains the status record of materials either on hand or anticipated. The control subsystem makes decisions based on these communications and records to initiate the order or movement of material. Although the communications and control subsystem is often most difficult to identify, its efficiency is most critical to the effective operation of logistics system.

2.2.5 Human Resources

Not all of the logistics system is encompassed in physical facilities - warehouses, transportation, telephone lines, and computers. The system also includes and effects the people. People who are related with logistics system such as drivers, salesman, warehouse operators and warehouse managers etc.

The above is very brief description of the logistics system elements.

2.3 Logistics System Decision

Today, greater logistics system possibilities and changing cost structures have forced a re-evaluation of past choices of system elements. Structural changes in the transportation and storage industry, increases in costs and technical advances have caused changes in the cost and availability of the transportation services. Modern communication and information processing

techniques have also introduced possibilities for much greater speed and complexity of information transfer and handling and thereby, for new system operating techniques design to achieve tighter and more sophisticated control.

Logistics systems differ from one to another in physical form, location of factory sites and functions ,warehouses, modes of transportation and so forth ,and also in operational policies and techniques. The following is the summary of the decisions in logistics systems. All of these decision in the end affect the customer service or service policies (the customer service has a different concept for each company).

Christopher identified six decision areas within the total logistics approach [Christopher 1972]; Facility location or Warehouse or Depot location, Inventory allocation, Transportation, Communications, Unitization and Customer service levels.

Ballou's definition of logistics system decisions include a transportation system, a storage system, a material handling system, a packaging system, a production control system, and physical location of each of these to the other [Ballou 1973]. They may be described in more detail as follow:

A. Transportation

- (1) Mode and service selection;
- (2) Carrier routing.

B. Inventories

- (1) Stocking policies;
- (2) Record Keeping;
- (3) Purchasing;
- (4) Short-term sales forecasting.

C. Customer service

- (1) Needs and wants;
- (2) Response.

D. Order Processing/Information Flows

- (1) Order procedure;
- (2) Information Processing;
- (3) Data analysis.

E Warehousing

- (1) Space determination;
- (2) Stock layout and dock design;
- (3) Stock placement;
- (4) Warehouse Configuration;

F Material Handling

- (1) Equipment Selection;
- (2) Equipment Replacement;
- (3) Order picking;
- (4) Stock storage/retrieval.

G Protective Packaging For

- (1) Handling;
- (2) Storage;
- (3) Protection.

H Production Scheduling

- (1) Aggregate production quantities;
- (2) Sequencing /timing or production.

I Facility Location

- (1) Location, number, and size of facilities;
- (2) Allocation of demand to facilities.

Magee considered in much more detail the decisions related to the design of a logistics system [Magee et al 1985]. They were as follow:

2.3.1 Number and Location of Plants

A logistics system may have one plant, mill, or factory, or it may have several. The location decision may be forced by material availability or may be made to reduce the labour dependence. If there is more than one plant,

these may serve geographical markets and may make complementary product lines, or the product line may overlap only in part. Related variables are the numbers and location's of suppliers. Most companies have limited capability to influence the supplier patterns and therefore must locate plants to minimize inbound transportation cost in conjunction with operating, outbound transportation and other costs.

2.3.2 Number and location of Warehouses:

A warehouse may be maintained at each factory, or a few warehouses may be set up as a central point or points to receive the products of suppliers or the output of the plants. These warehouses consolidate and ship combined lots of products. Field warehouses may be set up to improve the speed of the service to markets and reduce the transportation cost. In addition, however subsidiary warehousing centres, depending on the product and market concentration, may be set up to serve special needs, such as requirements of a major customer or local distribution in a major market. Changing the number and location of the warehouses will change the number of customers who are close to warehouses and thus the service provided to customers, and also will change the total cost of warehouse and inventory and the total system cost.

2.3.3 Modes of Transportation

The decision maker may chose among a variety of modes such as ship, truck, air-freight, less than carload, less than truckload, express, parcel post, and possibly other means. He or she may choose among common carriers, contract carriage, or transport owned and operated by the firm (third party distribution). These transportation modes have different cost, different time, different reliabilities, and different handling and packing characteristics and as a consequences the designer's choice of transport mode influences other parts of the logistics system and ultimately the cost and service level of customers.

2.3.4 Communications

The facilities in the system are linked by a communications and control network as well as a transportation network. Choices for communications service over links in the system include the mail, cable, telex, exchange telephone and high-speed computer to computer links (electronic data interchange), each with its own time, reliability, and cost characteristics. In the past most communication links in the physical distribution system were served by the mail and telephone. Some type of direct transmission is most common today. The choice of transportation and communication services and the choice of physical facilities, have a strong influence on one another and on logistics system.

The above are major decisions of the logistics system but by no mean complete. There are some operational decision such as product availability, service reliability, product stocking location, product design and the nature of product that also need to be taken in account.

2.4 Channels of Distribution

"The distribution channel is the least understood area in the logistics". [Bowersox 1973]. This is no longer true because a great deal of research has been carried out since this statement. In this section the definition and structure of distribution channels and their impact on logistics systems will be described.

2.4.1 Definition of Channel

A number of definitions of channels of distribution have been made as follows;

The American Marketing Association defined the distribution channel as:-

" the structure of the intracompany organisation units and extra company agents and dealers, wholesale and retail, through which a commodity, product, or services is marketed ."

[Alexander 1960]

Theodor et al defined the distribution channel as :-

"a grouping of intermediaries who take title to a product during the marketing process, from first owner to last owner."

[Theodor et al 1962]

" A channel of distribution comprises all the institutions involved in moving goods or services from producer to end user or consumer."

[Wills et al 1972/73]

Bowersox defined the distribution channels:-

" The logistical channel consists of a number of independent enterprises which combine to deliver product and material assortments to the right location at the proper time."

[Bowersox 1978]

Magee et al stated:-

" The distribution channels serve as the link between manufacturers and the ultimate consumers or users of a product, and these channels perform a variety of functions as part of that link, including sales, marketing, promotion, credit, order taking, customer service, customer relations, and merchandising."

[Magee et al 1985]

Rushton et al provided the following definition:-

"The physical distribution channel is the term used to describe the method and means by which a product or a group of products are physically

transferred, or distributed, from their point of production to the point at which they are made available to the final customer. In general, this end point is a retail outlet or shop or factory, but it may also be the customer house because some channels by pass the shop and go direct to the consumer."

[Rushton et al 1989]

Therefore the physical distribution channel may be define as:-

" The physical distribution channel is composed of terminal nodes, such as factory and shops and intermediate nodes, such as distribution depots, transshipment points and the links between them, represented by freight movements"

2.4.2 Channel Types and Structure

The functions performed by distribution channels are divided amongst manufacturers ,wholesalers, and retailers. The functions assigned to these participants vary considerably among industries and even among companies within an industry, usually dependent on the product, size and geographical location of the company.

There are several alternative channels of distribution that can be used, and a combination of these may be incorporated within a channel structure as depicted by Rushton et al [Rushton et al 1989] and given in figure 2.8. Some of these are described in detail as follow;

Manufacturer direct to retail shop:

In some case when full vehicle load is being sent, manufacturer use this channel and deliver its direct to customers.

Manufacturer via manufacturer's warehouse to retail shop:

This is the classical distribution channel and most widely employed in

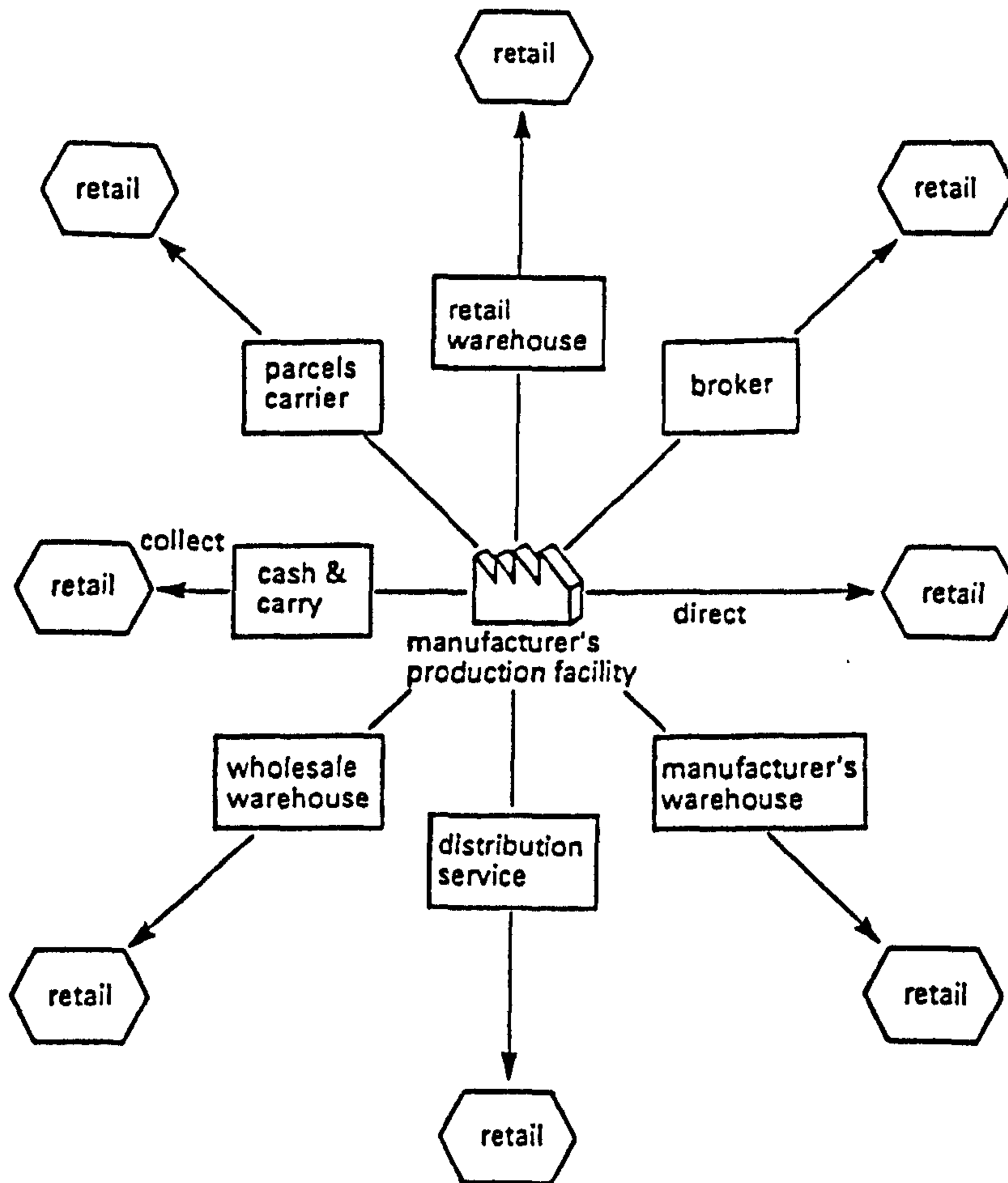

Figure 2.8

Alternative distribution chains from manufacture's product through to retail distribution points
(Source Rushton et al 1989)

distribution industry. In this structure the manufacturer holds his products in a central distribution depot or in a series of regional depots. The products are moved in large vehicle to the depots where they are stored and then broken down into individual orders which are deliver to the customers.

Manufacturer via retailer warehouse to retail shop or store:

This channel consists of the manufacturers supplying to central or regional distribution centres. These distribution depots are run by retail organisation and they deliver goods from these depots to their outlet in their own vehicles.

Manufacturer via distribution service to retail shop:

In this case, third party distribution company picks goods from manufactures and by using its own distribution depots networks, delivers it to the required destination.

2.4.3 Effects on Logistics Systems

Great emphasis is now placed on the need for developing a total systems approach to logistics. The components of distribution channels are the components of a logistics system. Changes in logistics technology and, in many cases, increased emphasis in total quality by many firms (including quality of customer service) have had a profound effect on the structure of distribution channels and the roles performed by the various participants. This has, in term, been of consequence to the design of logistics system as whole.

2.4.4 Just-in-Time (JIT) and " Pull Systems"

For many years supply chain has been seen as an extra inventory, providing a buffer for production or transport problems. Since the 1950's Japanese production philosophy of JIT or "Pull-System" have been gaining support and popularity. In more recent years the advantages of JIT in the supply chain

have been increasingly.

JIT is very simple in concept. Its goal is to produce, assemble or move exactly the right quantity of goods at exactly the right time, in order to have zero inventory throughout the entire supply chain [Saw 1990]. JIT is called a "pull system" because the despatch of finished goods pulls parts through the process by the vacuum left behind. Other methods are called "push system" if they push raw materials or components into the process regardless of how much finished product is being despatched. This leads to high levels of inventory.

JIT methods have been known to fresh food producers for many years, and were chosen by the early mass production car makers. But it is since 1950 that Japanese have adopted the JIT philosophy and have perfected various techniques for applying it. The best known is 'Kanban' which was developed at Toyota. 'Kanban' uses cards to trigger action from an upstream manufacturing or purchasing process when, and only when, the down-stream supply is depleted. It demands high quality, low breakdowns, short lead times and small batch sizes. The price for JIT is a low level of contingency, and some excess capacity to meet peak demand.

Although it is easy to understand in principle, JIT is very difficult to implement in practice. Throughout the supply chain, right back to the supplier or sub-contractor, small quantities of high quality goods must be available at the right time. This will usually only come from long term contracts and detailed planning information. Production processes have to be changed to balance lines, worker must be flexible, layouts changed and parts delivered to the point of manufacture. Designs have to be changed to ensure maximum flexibility; machining and assembly systems are required to change from one model to the next with minimum set-up.

2.5 Logistics System Cost

When planning or running a logistics operation it is important to be cognizant of the key costs that are involved in the total logistics system and how these cost interact with each other. The integral parts of the logistics system necessarily interact with each other to form the system as a whole. Within this system, it is possible to trade-off one element with another, so gain an overall improvement in the cost of effectiveness of the total system. An understanding of the make-up and relationship of these key costs is thus a vital bond to successful distribution planning and operations. The following cost of a logistics system will be considered; warehousing cost, transportation cost, inventory cost and total system cost.

2.5.1 Warehousing cost

Warehouse costs depend primarily upon the volume and nature of throughput, together with storage and handling methods employed. They may also depend upon a number of other factors such as place of location and percentage utility of the warehouse space, and technology employed. The total warehousing cost is combination of above.

2.5.2 Transport cost

The cost of transport depends primarily upon the type and amount of goods carried from location to location, the method or mode of transport, and the distance between locations. Where more than one location is served on a single vehicle trip, the separation of cost becomes more difficult. Clearly, the positioning of the depots in the system will affect the source and destination locations served by the transport function, and transport cost may therefore vary significantly with the number and location of the depots. The transport cost may be divided into two categories, local delivery cost and trunking cost.

2.5.2.1 Local delivery cost

Local delivery is concerned with the delivering orders from the depots to the

customers. The cost of delivery is related to the distance that has been travelled. The distance is divided into two types.

- a) Zone distance; The distance travelled during the delivery zone.
- b) Stem distance: The distance between depot and delivery zone.

If the zone area and the number of customers in the area are fixed, zone distance remains the same whatever the distance from supplying depot. 'Stem' distance varies according to the number of depots in the system.

2.5.2.2 Trunking cost

The trunking or primary transport element is concern the supply of products in bulk (ie in full pallet loads) to the depots from the central warehouse /production point. The overall cost of this type of transport is affected by the number of the depots in the distribution system. This cost normally increase as the number of depot increase in the system.

2.5.3 Inventory cost

The formulation of inventory policy is fundamental to determing the stock hierarchy on which a warehouse structure might be based, and indeed the distribution study should ideally be carried out hand in hand with an inventory study. Costs clearly vary with the depot structure, and are sometimes represented implicitly as part of the warehousing costs and sometimes separately.

2.5.4 Total Distribution cost

By its very nature, a logistics system operates in a dynamic and ever-changing environment. This makes the planning of a logistics system a difficult process. By the same token it is not easy to appreciates how any changes to one of the major elements within in a distribution structure will

affect the system as a whole. One way of overcoming this problem is to understand the total system as well as their internal relationship to each other. Rushton et al [Rushton et al 1989] states that;

" Total distribution cost analysis allows this approach to be developed on a practical basis. The various costs of the different elements within the system can be built together to provide a fair representation, not just of the total distribution cost itself, but also of the ways in which any change in the system will affect both the total system as well as other elements within the system."

Total cost against the number of depots in the system is plotted by Rushton et al [Rushton et al 1989] and depicted in figure 2.9.

2.6 Conclusion

In this chapter, definition of logistics system structure and how these evolved with space of time are discussed and different definitions are recorded from the literature. The distribution structure and its components and logistics systems elements and their functions are described in details. The decisions involves to design a logistics systems such as location of depots, selection of mode of transport and type of vehicles and means of communication are given. Different definitions of distribution channels from the literature are stated and explained. Also their impacts on a logistics systems are discussed. The different cost of a logistics system are described. In each case a detail account is provided for each cost. The total cost has been plotted against the number of depots in literature and has given here.

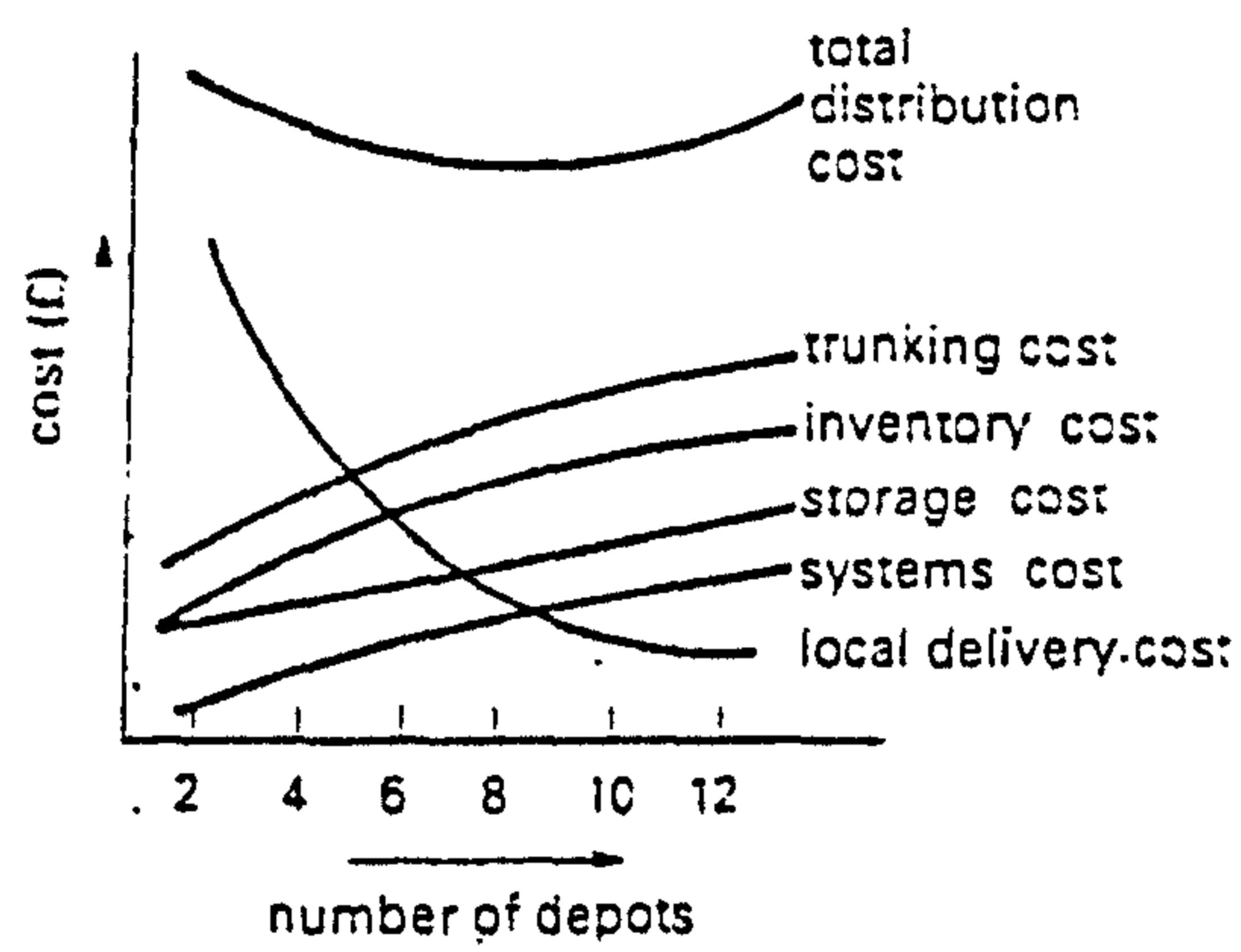

Figure 2.9 Total distribution cost as a function of number of depots, showing the constituent cost elements that comprise the total (Source Rushton et al 1989)

Chapter Three

Literature Review

3.0 Introduction

The warehouse location problem with its associated distribution management issues is not new to the science of the operational research and management. The literature spans well over four decades. As with many classes of problems in management science, the distribution/location problem is very diverse. Models in this class range from a very simple single commodity linear deterministic formulation to multi-commodity nonlinear stochastic versions. It is the purpose of this chapter to review some of the more significant work which has contributed to the present state of knowledge. This chapter has been organized in order to progress from physical models through to mathematical models, visually interactive models and concludes by describing the application of these models in a practical environment.

3.1 Physical Interactive Models

Physical interactive models were the most important techniques for depot location before the advent of digital computers. In this section centre of gravity models, electric analogue models and models which were developed by using mechanical analogue will be reviewed.

3.1.1 The Centre of Gravity Method

The centre of gravity method is also known as a grid method or centroid method and has been employed for depot location for some time [Keffer 1934, E.C.D 1967]. This method has been extensively referenced in the academic literature as an approximate method of locating a fixed facility [Ballou 1973]. The centre of gravity method is essentially a single facility location procedure. It involves determining the X and Y co-ordinates for a facility that is to receive goods from and to distribute goods to a number of points. A grid is placed over the supply and demand points and the computations are keyed to the grid coordinate locations of the points. The

location of the facility is then found by solving for the location in the horizontal direction (X) by

$$X = \frac{\sum_i V_i R_i X_i}{\sum_i V_i R_i}$$

and in the vertical direction (Y) by

$$Y = \frac{\sum_i V_i R_i Y_i}{\sum_i V_i R_i}$$

Where

X, Y = the grid coordinate locations of the facility;

X_i, Y_i = the grid coordinate locations of the supply and demand points;

V_i = the volume flowing from or to the supply or demand point;

R_i = the transportation rate to ship V_i from or to the supply or demand point.

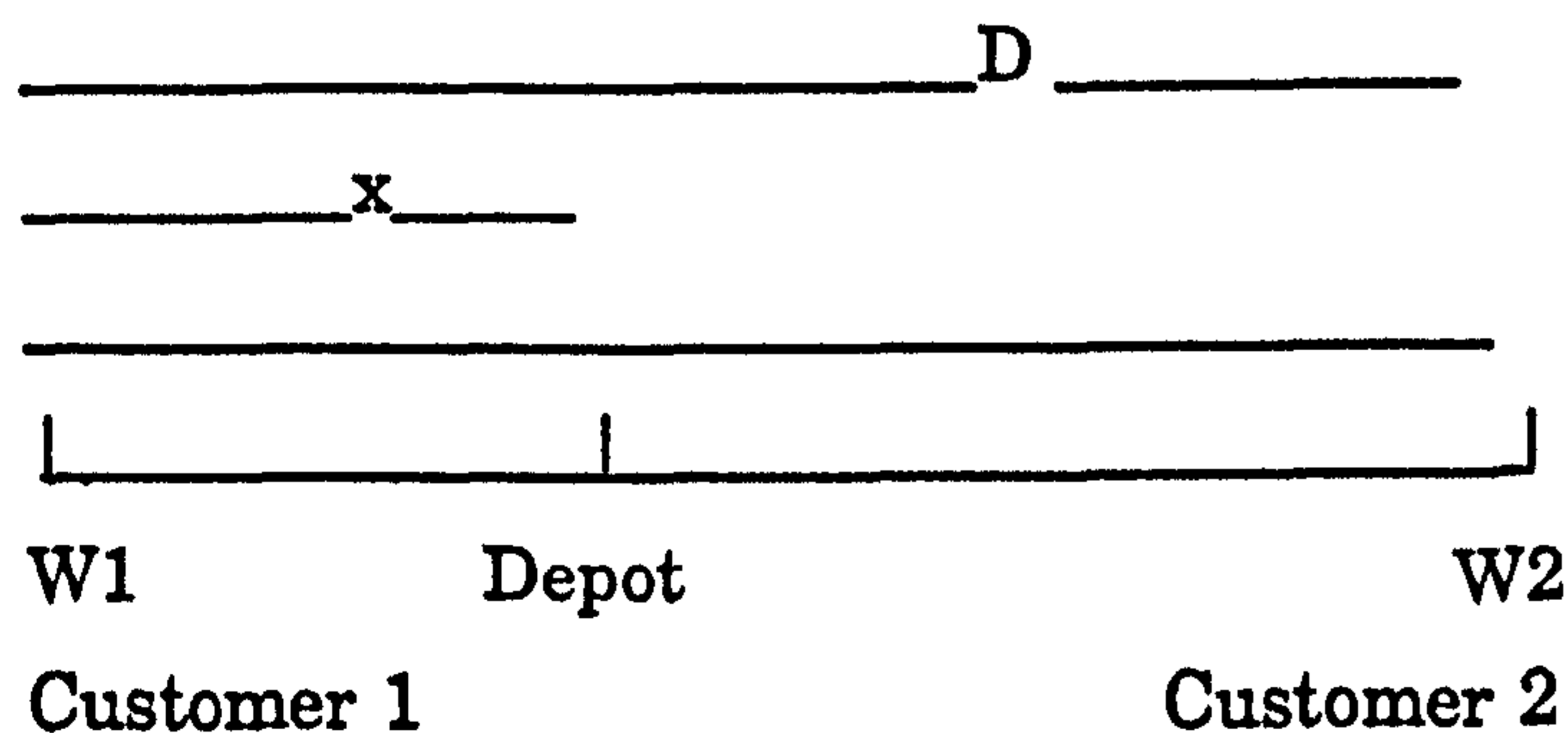

Figure 3.1

Eilon et al considered two customer problems [Eilon et al 1971], where the weight of the customers are W1, and W2 respectively and the two are

distance D apart as shown in figure 3.1. If the depot is located at a variable distance x measured from customer one, then the moment of the system with respect to depot is given by:

$$M = W_1 x + W_2 (D - x)$$

OR

$$M = (W_1 - W_2) x + W_2 D \quad (3.1.1.1)$$

Differentiating with respect to x

$$\frac{dM}{dx} = (W_1 - W_2)$$

Thus if $W_1 > W_2$ then x must be made as small as possible in order to minimise the value of M ; therefore

$$x = 0$$

namely the depot should be located at the site customer one. Similarly, if $W_1 < W_2$, then the depot should be located at customer two, while for $W_1 = W_2$ any point between the two customers will yield the same result.

Consider now the centre of gravity for this system. The result for X_o is given by

$$X_o = \frac{\sum W_j X_j}{\sum W_j} = \frac{W_2 D}{(W_1 + W_2)}$$

Here the x values are measured from customer one and therefore $X_1 = 0$. The moment of the system M_{x_0} at the centre of gravity is given by substituting X_0 for X in equation (3.1.1.1). Hence

$$M_{x_0} = \frac{(W_1 - W_2) W_2 D}{(W_1 + W_2) + W_2 D}$$

$$= \frac{(2 W_1 W_2 D)}{(W_1 + W_2)} \quad (3.1.1.2)$$

To show that centre of gravity is not necessarily the best place for the depot they consider the three cases:

i) If customer one demand is greater than customer two ($W_1 > W_2$) then, the depot location for minimum costs is at the site of the customer one. The moment M_0 of the system at this location is given by

$$M_0 = W_2 D \quad (3.1.1.3)$$

The moment at the centre of gravity is given by the equation (3.1.1.2); hence the ratio of the moment at X_0 to the minimum is

$$\frac{M_{x_0}}{M_0} = \frac{(2 W_1 W_2 D)}{(W_1 + W_2) W_2 D}$$

$$\frac{2W_1}{W_1+W_2} > 1$$

ii) When both customers have equal demand ie ($W_1 = W_2$) and are equal to W then any point x between the two customers will give the minimum value. Therefore equations (3.1.1.1) for H_o is reduced to equation (3.1.1.3) so that

$$\frac{M_{xo}}{M_o} = \frac{2W_1}{W_1+W_2} = 1$$

Thus when W_1 is equal to W_2 then centre of gravity corresponds to the minimum value of the objective function.

iii) When customer number two's demand is greater than customer number one's (ie $W_2 > W_1$) then as shown above, the result is given by :

$$\frac{M_{xo}}{M_o} = \frac{2W_2}{W_1+W_2} > 1$$

Vergin et al also proved that centre of gravity does not give an optimal solution [Vergin et al 1967]. They stated that when the tonnage at each destination does not vary by a large amount the centre of gravity produces a result quite close to the optimal locations but when there is considerable disparity then error in this process increases rapidly.

The error in the centre of gravity model was investigated by Ballou and results are shown in figure 3.2 and 3.3 [Ballou 1973].

Figure 3.2 was produced under the following conditions: unequal weights, randomly selected points and linear transportation rates.

Figure 3.3 was produced by using unequal weights, randomly selected points and tapered transportation rates.

The following conclusion may be drawn from Ballou's results [Ballou 1973]. The error in the centre of gravity model decreases as the number of supply and demand points increased in the location problem. Supply and demand points configuration greatly affects the accuracy of the centre of gravity model.

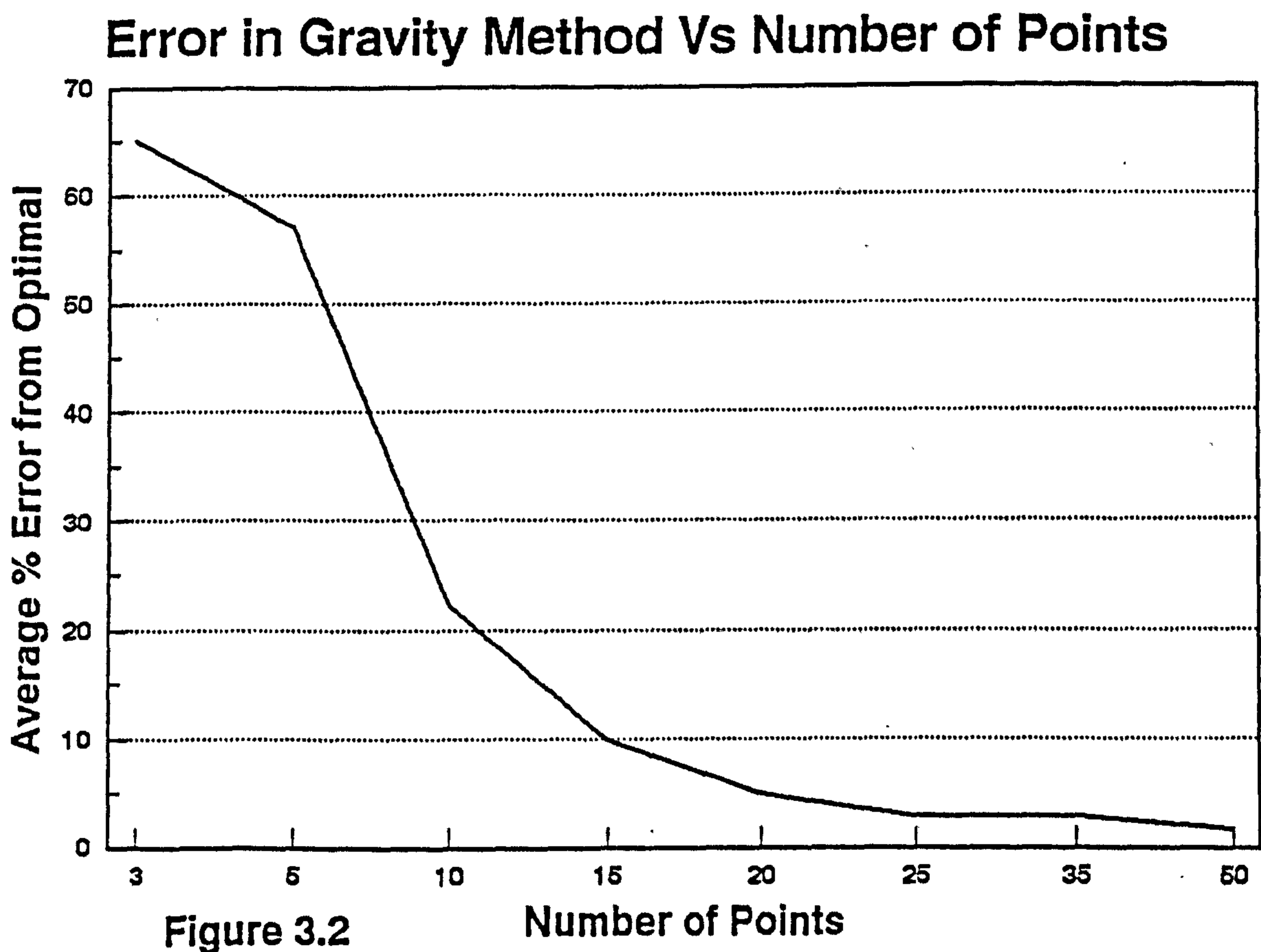

As shown the centre of gravity model does not give the optimum or least cost location. The reason for this is that grid models treat horizontal and vertical distances as independent of each other and also centre of gravity method minimise the d^2 . In fact the hypotenuse of the distance triangle is the relevant distance on which to base the location analysis.

Error in Gravity Method Vs Number of Points

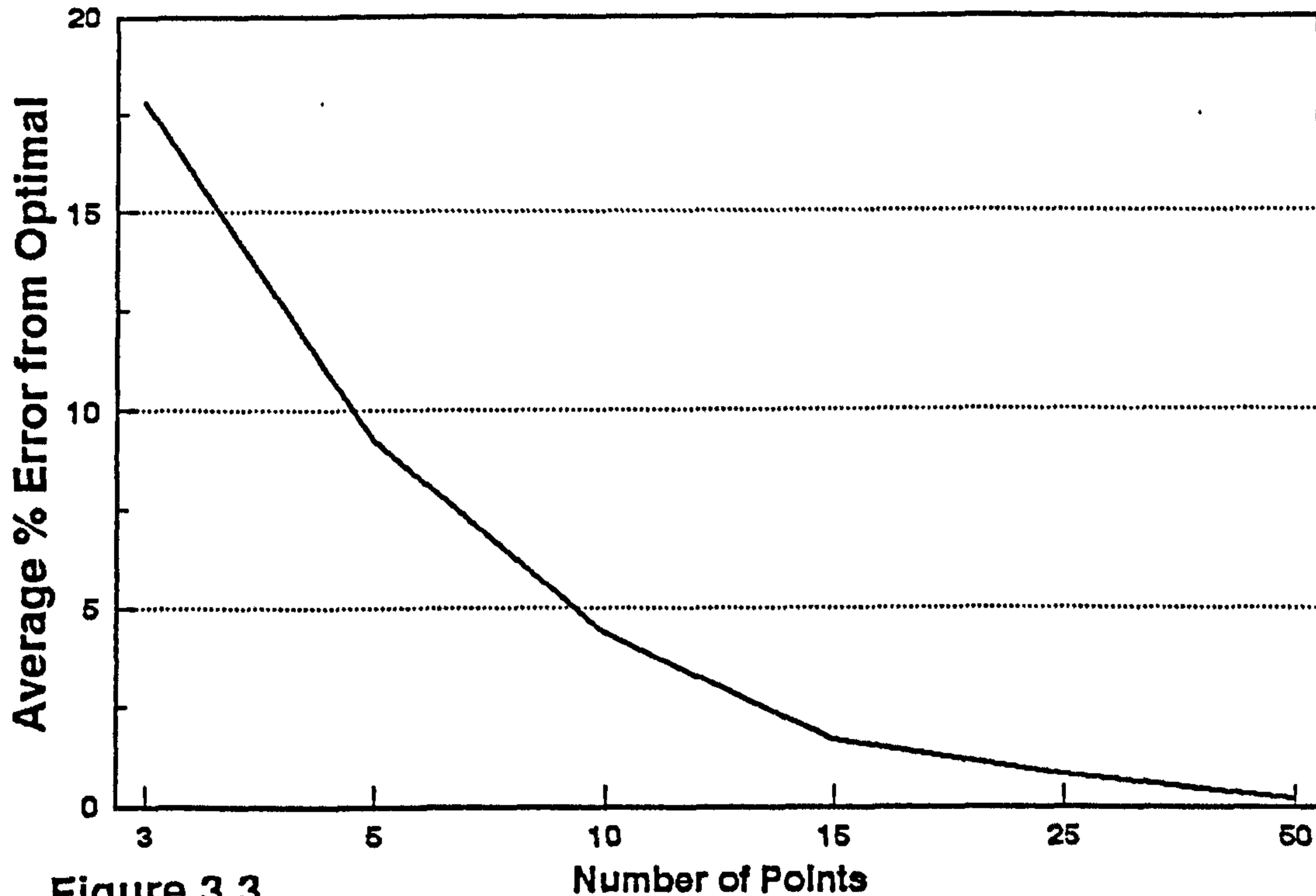

Figure 3.3

The major disadvantages may be summarised as follows:

It may give a near-optimum solution but it does not guarantee the optimum solution [Ballou 1973]. A certain amount of distance distortion results from placing a rectangular grid over the spherical earth. This distortion increases with the size of the geographical area being studied [Lewis 1970]. Transportation costs employed are assumed to be directly proportional to distance and it is further assumed that the same proportionality constant applies in all directions. In reality this relationship seldom exists in an exact sense [Scott 1970]. It assumes that the solution includes only one transshipment location or it assumes arbitrary boundaries to produce multiple transshipment locations within each arbitrary zone. It assumes that the straight line distance between two points is representative of actual distance. It ignores processing cost differentials at different facilities. It ignores capacity constraints, service requirements, multilevel service requirements and multilevel logistical systems. It yields answers that are often impractical locations: the middle of a lake or desert or a point far from transportation services. It assumes given shipment volume out of each plant.

It does not provide the means to estimate how far from the optimum is the calculated cost. It does not provide the sensitivity analysis. It assumes one product or a uniform mix of products throughout.

However such a method has some advantages in that it overcomes some of the computational difficulties, and it is perhaps the easiest of all single facility models to use [Bowersox 1962]. It gives good first approximations to least cost solution. It will give the optimum solution for a single facility when there is perfect symmetry in the arrangement of the market and supply points. That is, the point from the pattern of a perfect square, equilateral triangle, regular polygon, etc., and the mathematical product of demand multiplied by the transportation rate is equal for all points. Vergin et al estimate that on the average the grid method will give results that are 6.2 percent greater than the optimal location cost [Vergin et al 1967]. A 6% error may be worth accepting for the benefit of the simple and easy to use location methodology.

3.1.2 Electrical Analogue

In Distribution System Modelling, all cost functions may be modelled by using a physically visually interactive electric analogue. The first such system was used by Brink et al which employed the vector function [Brink et al 1957]. The problem they considered was as follows;

n = number of customers ($i = 1, \dots, n$)

customer locations = (x_{i1}, x_{i2})

m = number of distribution depots ($j = 1, \dots, m$)

Distribution centre locations = (y_{j1}, y_{j2})

Demand of customer $i = D_i$

crow-flight distance = $|x - y|$

Cost from Distribution centre j to customer $i = C_{ij}$

$$C_{ij} = D_i \int |x - y_j| \quad (3.2.1.1)$$

They used an especially designed electric analogue which only treated certain types of problem involving two-dimensional scalar fields. It was particularly useful for problems in which total scalar field $\Phi(x, y)$ was due to given distribution of $N^{(2)}$ elementary field $\phi_i(x - x_i, y - y_i)$, where $i = 1, \dots, n$ and (x_i, y_i) is the original location of those fields. In their analogy the coordinate (x_i, y_i) represented customer locations, the elementary field ϕ_i represented the delivery cost C_{ij} and the total field Φ represented the total transportation cost C .

On evaluating the total field Φ , they used an image scheme. First they arranged N elementary fields ϕ_i at their proper relative positions. They determined the total scalar field $\Phi(x, y)$ at different point (x, y) with a single detector which summed up the contributions of various elementary fields at that point. The image scheme they employed utilized a single elementary field together with N detectors positioned according to the distribution of the elementary fields. They observed a complete symmetry between the two schemes when the fields differed only by scalar factor and the scalar factor was represented by the demand D_i .

In their model the crow-flight distance between depot and customer was represented by a single elementary field. They used high resistance conducting paper on which they drew selected equipotential lines with silver conducting paint. They imposed appropriate voltages by using a battery and a simple voltage dividing network. They appreciated that it was not possible to obtain a perfect analogue of the desired function, but interpolation between the equipotential lines afforded by the conducting paper pattern yielded a good approximation to this function, using relatively few equipotential lines. They stated that fidelity of the pattern is determined by the complexity of the function, f , and the number and judicious selection of

the conducting paint lines.

Their system consisted of N detectors, spring-loaded sliding brass pins. They positioned the pins in a plastic detector sheet according to the specified distribution of customer locations. They mounted a plastic detector sheet parallel to the fixed horizontal plan of the pattern and maintained suitable electric contact by the pressure of the springs. They moved the detector sheet in both directions parallel to the pattern in order that the total transport cost C may be determined at various points. They inserted N resistances, one for each pin between the detector pins and a common terminal. The resistances was made inversely proportional to the demands (D_i). They reported that voltages sampled by the pins are on the same "scale" but the corresponding detector current reflected the differences in demand at each of the customer locations.

The essential features of their electric analogue are shown in figure 3.4. The three detector pins represent the customer locations. The customer demands are represented by appropriate resistances. They stated that by mechanical means the detector sheet can be moved continuously in the plane parallel to the pattern in such a way as to maintain the current meter at a constant level. They also attached a tracing arm to the detector sheet. When they moved the detector sheet, the tracing arm traced an irregular equi-field line on a map or piece of graph paper. This equi-field line is an iso-cost line.

Brink's model only deals with a single depot location and its optimisation [Brink et al 1957]. It also calculates the cost for the depot to be located anywhere in the market area. It assumes that transportation cost is linearly relative to the distance.

Eilon et al described a general electric analogue model which uses the sine wave function where Brink et al employed vector function [Eilon et al 1966]. Their model also uses the linear transportation cost and deals with a single

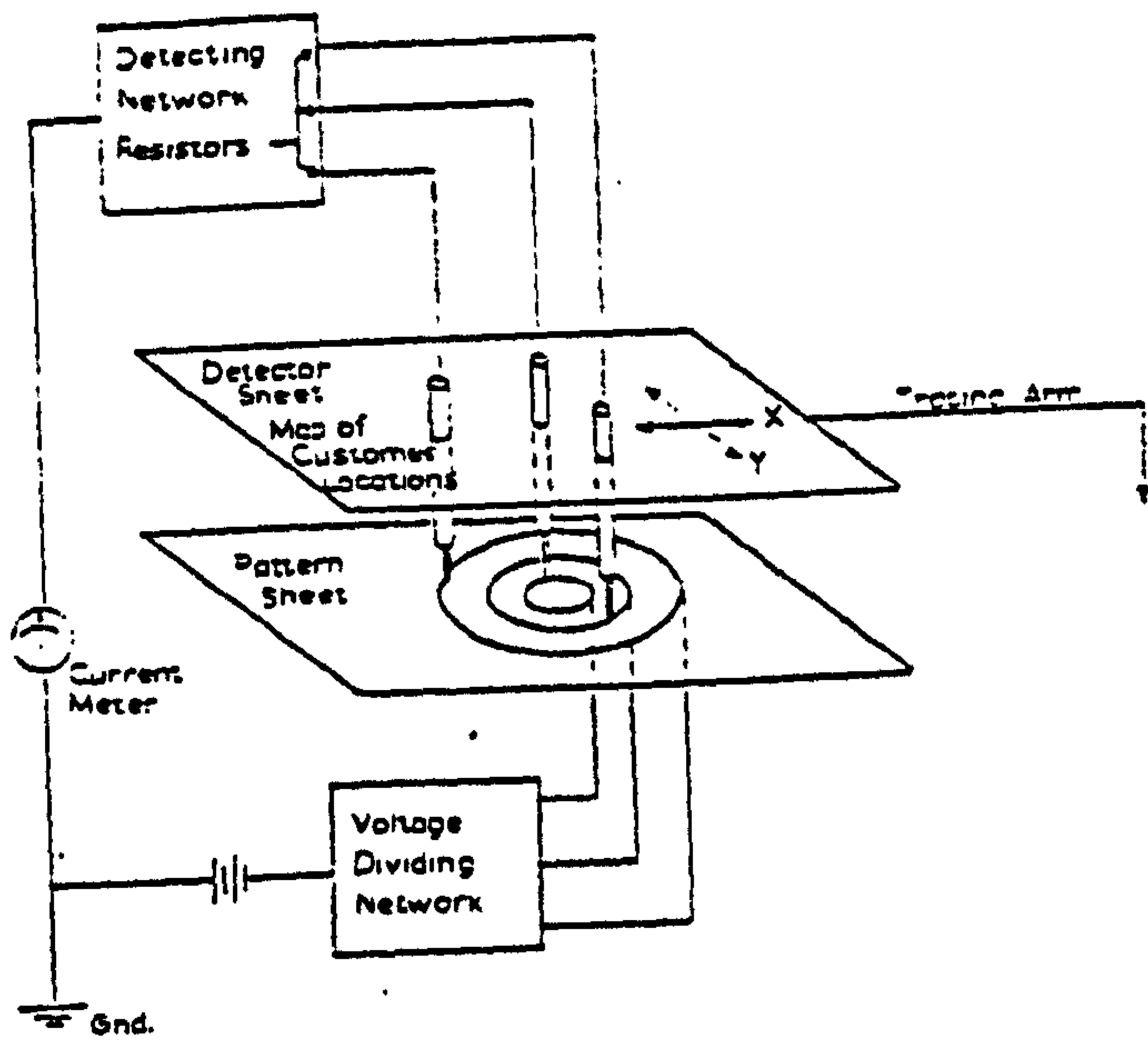

Figure 3.4 Electric Analogue
(Source Brink et al 1957)

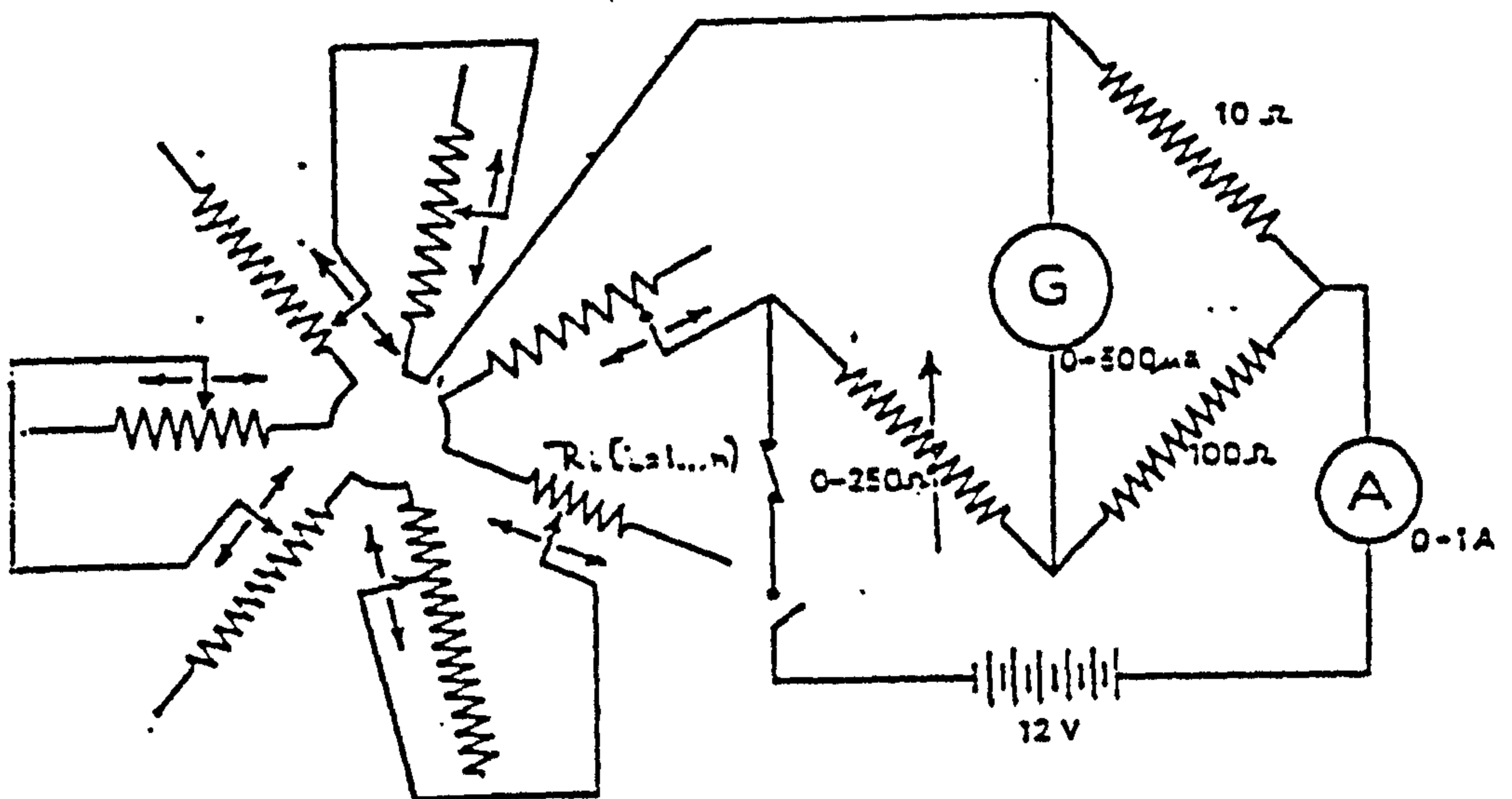

Figure 3.5 Electric Analogue
(Source Hitching 1969)

distribution depot.

Hitchings developed an electric analogue based on slide wire principle [Hitchings 1969]. In his model the distances were represented by resistors which were made proportional to the length of the wire. The demand was represented by resistivity of the material (dissimilar materials). In case of similar material it was proportional to the cross sections area.

Hitching's model's diagram is shown in figure 3.5. The nonlinear transportation cost was accommodated by altering the resistors, i.e by segmenting it into appropriate lengths, and specified the resistances of particular lengths for stated conditions. He used the model to consider the problem in planar and spatial states.

The major advantage of an analogue computer may be summarised as follows:

Solutions may be obtained rapidly so that detailed calculation is not necessary. For results the electric circuit needs to be in a steady state: for all intents and purposes this would appear instantaneously providing the model was a static one and not a dynamic one. An electric analogue provides the model with a certain utility which cannot easily be obtained with a digital computer model. Change in the model's parameters can be quickly evaluated by adjusting a few potentiometers rather than having to rerun the model as would be the case in the digital system. An electric analogue provides a better representation of the network system because it can be represented physically and does not rely on the numbers or the logic rules to constrain it. A manager therefore finds it easier to visualise the distribution system for this reason. An electric analogue does not rely on sophisticated hardware and complex software. Because of its simplicity and modular nature of such a system overheads caused by debugging and refining are not expensive compared to the digital system. A small model can be produced with an electric analogue and that can be subsequently integrated into a layout

model. Thus it is possible to assess the independence of the system being modelled. In contrast such interaction is most probably not feasible or possible in a digital model without having to re-address the fundamental aspects of the models. Complexity in the model such as hazards and barriers are incorporated more easily in electric analogue models than into digital models.

There are also some major disadvantages which may be summarised as follows:

Whereas an analogue model is limited in accuracy it can provide a solution due to resolution of the measuring instrument and accuracy of the resolution of the resistor. A digital model has a clearly defined accuracy that can easily be increased using arithmetic and greater precision. An accurate analogue model might be expanded to provide the results to one significant figure, by comparison a digital module using single precision arithmetic is likely to be accurate to seven decimal places and with double precision arithmetic it will be accurate up to 15 significant figures. Furthermore there is no theoretical limit on accuracy achievable using the digital model, providing that software is able to undertake the calculation with the degree of accuracy required. A digital model which does not necessarily require any purpose made hardware and can be run using modular concepts is now becoming very common. A digital model is not constrained by the physical attributes of its components eg an electric analogue model that represented cost as voltage and for which 1 volt represented £1 could not easily be used in excess of £1,000. A digital model provides in built facility for storage of results where an analogue model cannot easily practically store more than a very small number of trials. Digital models can be easily interfaced with commonly used peripherals such as graphic screens and plotters.

3.1.3 Mechanical Analogue

The distribution system also can be modelled by using physically visually

interactive, mechanical analogue [Haley 1963]. Haley considered the following problems:

Move a_i tons ($i=1\dots n$) from n factories through a single depot to m customers each of whom requires amounts b_j tons ($j=1 \dots m$). The factories are at the points (x_i, y_i) ($i=1\dots n$) in cartesian co-ordinates and the customers are at the points (x_{n+j}, y_{n+j}) ($j=1\dots m$). The position of depot is denoted by the variable co-ordinates (x,y) .

The cost of transport from the factories i to the depot are λ_i times the distance between the factory and depot, and from the depot to the customer is μ_j times the distance from the depot to the customer j , both per ton. The problem is therefore, to minimise

$$\sum_{i=1}^n a_i \lambda_i \sqrt{(x-x_i)^2 + (y-y_i)^2} + \sum_{j=1}^m b_j \mu_j \sqrt{(x-x_{j+n})^2 + (y-y_{n+j})^2}$$

$$= \sum_{i=1}^{m+n} w_i \sqrt{(x-x_i)^2 + (y-y_i)^2}$$

where

$$w_i = a_i \lambda_i \quad i = 1 \dots n$$

$$\left. \begin{array}{l} w_i = b_j \mu_j \\ x_{j+n} = x_i \\ y_{j+n} = y_i \end{array} \right\} \begin{array}{l} i = n + 1 \dots n + m \\ j = 1 \dots m \end{array}$$

Haley analogue consisted of a set of $(m+n)$ pulleys fixed at the points (x_i, y_i) ($i=1, \dots, n+m$) on a vertical plan, where n is the number of factories and m is the number of customers [Haley 1963]. Strings are passed over the pulleys. The lengths of strings are l_1, l_2, \dots, l_s and the distance of the pulleys from the

join are r_1, r_2, \dots, r_5 . One end of each string supports a weight W_i and the free ends are joined together as shown in Figure 3.6. The system is released and comes to rest at a position of minimal potential energy.

The potential energy of the system relative to the x-axis is:

$$\begin{aligned} & \sum_{i=1}^5 w_i [y_i - l_i - \sqrt{(x-x_i)^2 + (y-y_i)^2}] \\ &= \sum_{i=1}^5 w_i (y_i - l_i) + \sum_{i=1}^5 w_i \sqrt{(x-x_i)^2 + (y-y_i)^2} \\ &= \sum_{i=1}^5 w_i \sqrt{(x-x_i)^2 + (y-y_i)^2} + \text{constant} \end{aligned}$$

Haley stated that if the depot is located at the minimum potential energy position the cost would be minimal [Haley 1963].

Burstall et al modelled the location of one or more factories by using a mechanical analogue, as shown in Figure 3.7 [Burstall et al 1962]. Their analogue consisted of a map mounted on the table with holes bored at each source of raw material and each destination of finished product. They passed thread over each hole and the ends of the threads above the table were joined together in one knot. They attached the weight to the other end of each thread which was proportional to the demand at each centre. For a raw material Burstall et al used a different weight scale to take into account the difference in freight rate per ton between the raw material and the finished product. They overcame friction problem by shaking the knots slightly and stated that factory was moved to the place where transport costs were least.

The main advantages in using a mechanical analogue is that it has a visual impact, people can see and understand what is happening.

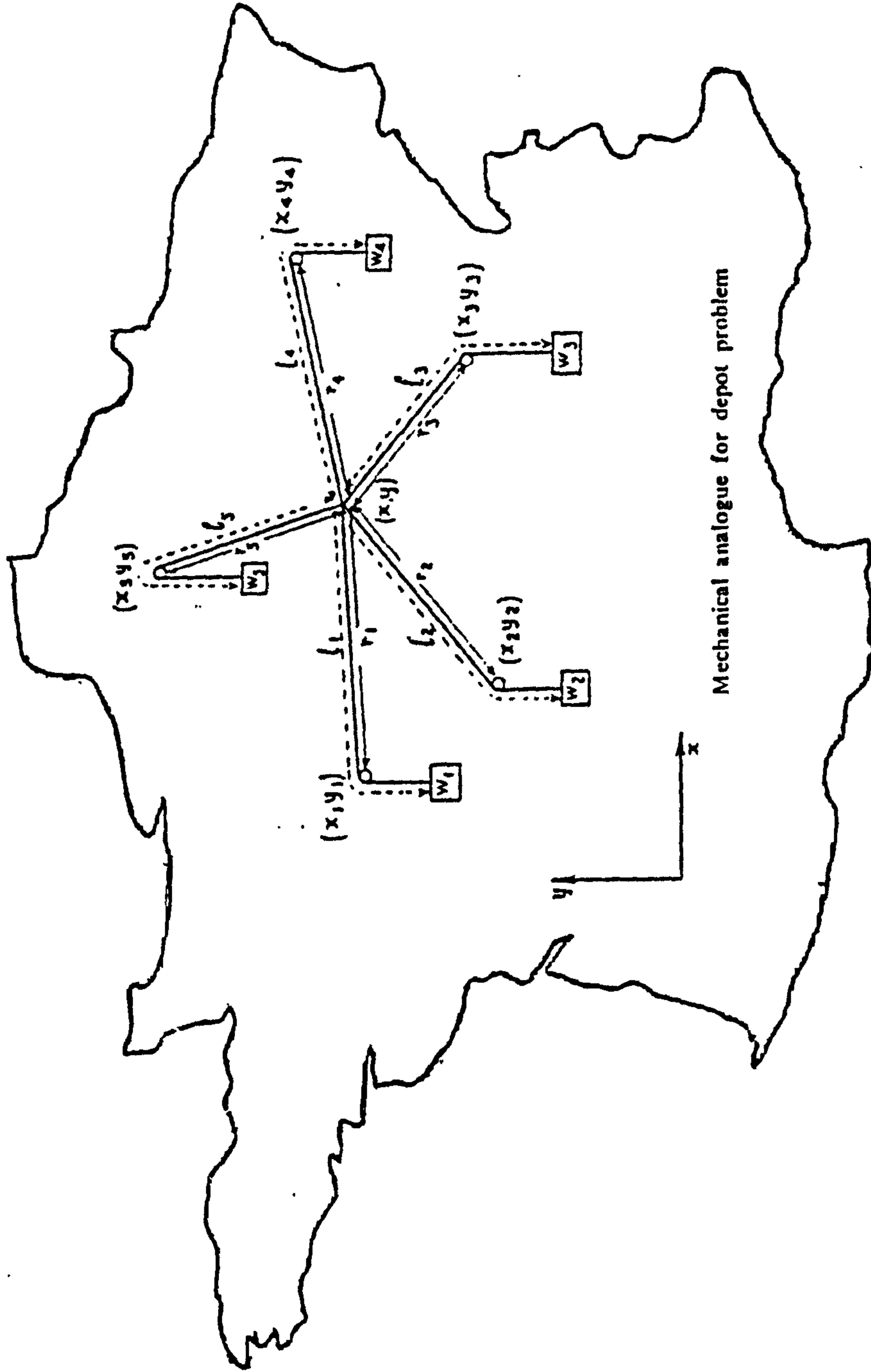

Figure 3.6 Mechanical Analogue
(Source Haley 1963)

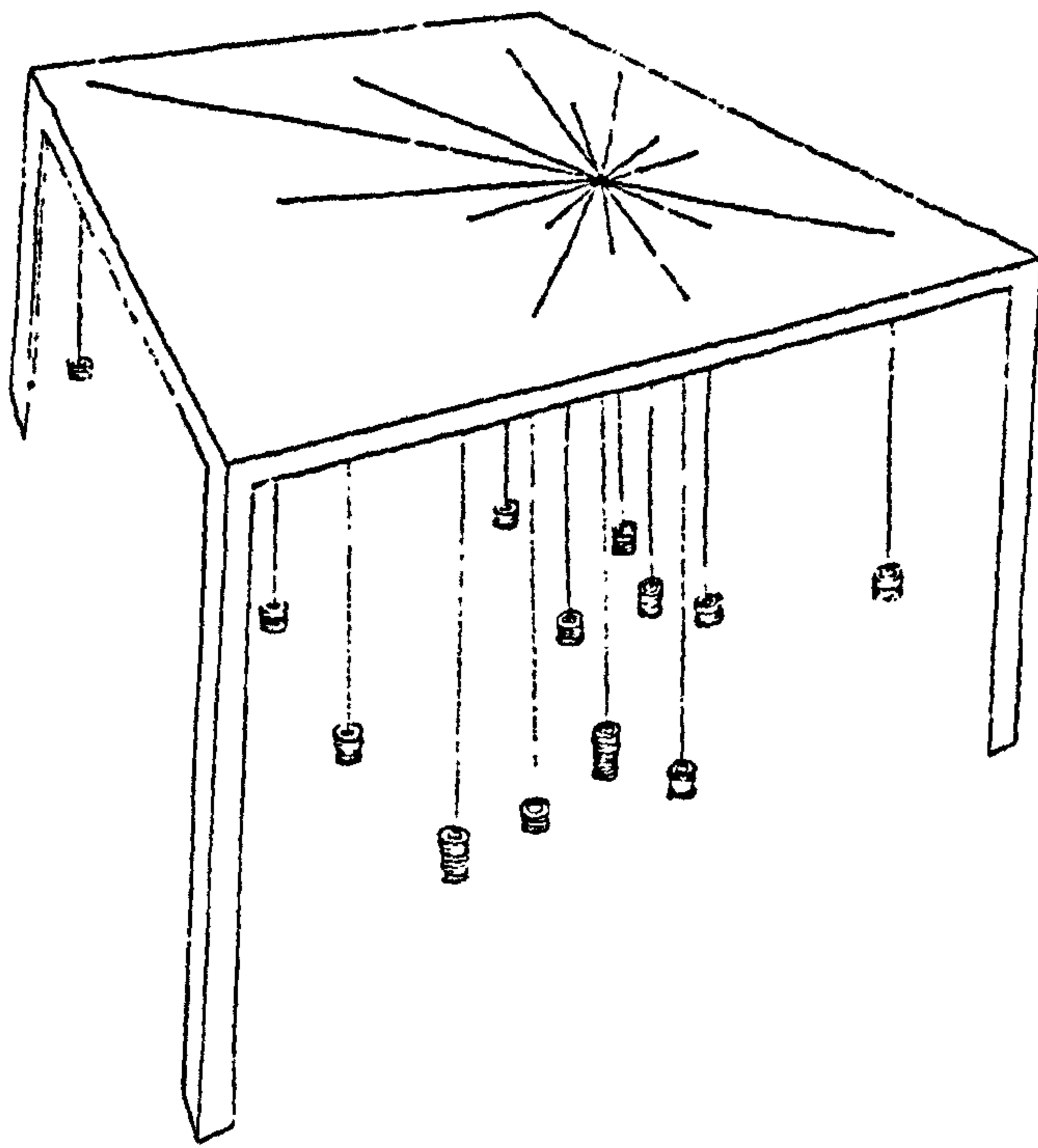

Figure 3.7

Mechanical Analogue

(Source Burstall et al 1962)

There are some major disadvantages in using mechanical analogues to model logistics systems. It implies a linear relationship between straight line distance on the map and transport cost. The analogue could not incorporate the extra cost for hazards and barriers. If distribution modelling involved more than one depot then sub-optimality may be derived. In modelling it does not evaluate the cost function.

3.2 Mathematical Models

The father of modern location theory was probably Alfred Weber who published his book *Uber den Standort der Industrien* in 1909 [Weber 1929]. However the major contribution to the development of logistics modelling was the advent of the digital computer. Many techniques which were developed prior to the digital computer era were unfeasible until the computer took over the complications of calculations necessary for applications.

This section has been organized with the general intent of progressing from the simplest through to the more complex in increasing order of solution complexity. This will not always follow and the order presented may be debated by some, since the more complex models have individual salient characteristics that make solution processes challenging. This section is not intended to prioritize these differences. Conversely, the objective is to illustrate the evolution that has taken place and the ever-increasing role of management science in the distribution planning field.

Models in the distribution/location class can be broadly classified according to

- i) Whether the distribution network is capacitated or uncapacitated (arcs and/or nodes);
- ii) The number of echelons (zero, single, or multiple) of transshipment points existing between supply nodes and demand nodes;

- iii) The number of commodities (single or multiple);
- iv) Whether costs are linear or non-linear (arc and /or node cost); and
- v) Whether the planning horizon is fixed (static) or permitted to vary (dynamic).

3.2.1 Uncapacitated Simple Facility Location Model

The simplest location model, which for convenience will be called the uncapacitated facility location model (UFL) and also known as simple plant location problem (SPLP) has the following formulations.

$$\sum_{i \in I} \sum_{j \in J} C_{ij} X_{ij} + \sum_{i \in I} F_i Z_i$$

Subject to

$$\sum_{i \in I} X_{ij} = 1 \quad j \in J \quad (3.2.1.1)$$

$$Z_i - X_{ij} \geq 0 \quad i \in I, j \in J \quad (3.2.1.2)$$

$$X_{ij} \geq 0 \quad (3.2.1.2)$$

$$Z_i \in (0, 1) \quad (3.2.1.4)$$

where

X_{ij} = the proportion of customer j 's demand is satisfied by facility i ,

Z_i = 1 if facility i is established 0 otherwise.

C_{ij} = the total production and distribution costs for supplying all of customer j 's demand from facility i .

F_i = fixed cost of establishing facility i .

$I, J =$ the sets of candidate facility sites and customer zones respectively.

UFL is a single commodity, uncapacitated, zero-echelon, linear model. Constraints (3.2.1.1) ensure that each customer's demand is satisfied exactly, and constraints (3.2.1.2) ensure that customers receive product only from open facilities. The model is zero-echelon (see chapter two) as there are no transshipment points. The facilities to be located are the supply points (either plant or warehouses) and how the supply is transported to these facilities is no concern of the model.

The Kuehn pairwise interchange, or "bump and shift" routine, although almost three decades old, is contemporary in the sense that the Kuehn battery of twelve test problems has been adopted as a generic standard against which algorithmic designers have been competing for computational efficiencies [Kuehn et al 1963]. Kuehn et al utilize the following three heuristic concepts:

- i) The best candidate locations will be near demand concentrations.
- ii) Near optimum results can be achieved by opening those warehouses one-at-a-time which produce the greatest cost savings for the entire system.
- iii) Only a small subset of all candidate locations need to be investigated in order to determine the next warehouse to open.

A main program locates warehouses one-at-a-time until no more warehouse can be opened without increasing the total system costs. Then a "bump and shift" routine investigates configuration modifications, specifically evaluating the profit implications of closing or relocating open warehouses.

Efroymsen et al utilized an implicit enumeration technique known as branch and bound [Efroymsen et al 1966]. The method involves a selective enumeration which is guided at each stage by a bound on the value of the

objective function obtained at that stage.

Let

F_j = the set of plant indices that can supply customer j .

c_i = the set of customer indices that can be supplied from plant i .

n_i = the cardinality of C_i

K_0 = the set of variable set to zero.

K_1 = the set of binary variables set to one.

K_2 = the set of binary variables which are uncommitted.

The problem becomes;

$$\text{Minimize } \sum_{i \in I} \sum_{j \in c_i} C_{ij} X_{ij} + \sum_{i \in I} F_i Z_i$$

Subject to

$$0 \leq \sum_{j \in c_i} X_{ij} \leq n_i Z_i \quad i \in I \quad (3.2.1.5)$$

and (3.2.1.4).

If constraints (3.2.1.4) are relaxed, unconstrained facility location is a linear programming problem which has an optimal solution given by

$$X_{ij} = 1, \quad \text{if}$$

$$C_{ij} + \left(\frac{g_i}{n_i} \right) - \text{Min}_{k \in K_2 \cup K_3} \left[C_{kj} + \left(\frac{g_k}{n_k} \right) \right]$$

0, otherwise

$$Z_i = \left(\frac{1}{n_i} \right) \sum_{j \in c_i} X_{ij} \quad i \in K_2$$

$$g_k = F_k \text{ when } k \in K_2$$

$$\text{if } g_k = 0 \text{ then } k \in K_1$$

The efficiency of branch and bound in this formulation is due to the fact that the non-integer results at each stage is an obvious solution to a simple linear programming problem. The proof is by contradiction. Assume that an optimum for a given stage has been achieved. Assume further that one or more of the constraints of type (3.2.1.5) for which Z_i has not been specified is satisfied as an inequality. The value of Z_i associated with such a constraint can be decreased until the constraint is met as a strict equality. However this decrease in Z_i leads to a decrease in the term $F_i Z_i$ in the objective function, which contradicts the initial assumption of optimality. Thus at a given stage those constraints of type (3.2.1.5) for which Z has not been specified will be met at equalities. Substitution of these values in the objective function yields a simple expression in X_{ij} , the solution which is immediately evident. A hidden advantage in the formulation, in addition to the fact that it terminates optimally, is that the solution is independent of all non-linearities in the transport cost function. Computational experience on problems with 50 warehouse locations and 200 demand area was reported.

Spielberg approached the problem from a different perspective [Spielberg 1969]. In Spielberg's implicit enumeration scheme, all facilities are either opened or closed. At each node, two solutions can be generated which will always be feasible. One solution (v') is obtained by dropping the fixed charges for any facility not used in the sub problem solution (flow of zero). A second feasible solution (v'') is obtained by solving a linear programming problem with all free variables relaxed, then rounding up all fractional values on the x 's. If $\min(v', v'') < v^*$ where v^* is the incumbent, set $v^* \leftarrow \min(v', v'')$. Spielberg reported computational results on a range of problem sizes.

Khumawala has also been a notable contributor to optimisation models, principally in the development of efficient branching rules for branch and bound [Khumawala 1972]. Khumawala has proposed four criteria of a branch selection, each embracing a pair of rules. These will be briefly described.

Delta rule:

In simplification, one delta i is computed for each free warehouse at every node. If $\Delta_i \geq 0$, then the warehouse i is fixed open for all branches emanating from the node. However, from the warehouses whose delta are negative, those having large delta value are likely to be open in terminal solution reached from this node. On the other hand, those warehouses having small delta values are likely to be closed in the terminal solution reached from this node. The two branching decision rules are based on delta are:

Largest Delta

Select the free warehouse which has the largest delta from the set of warehouses having negative delta.

Smallest Delta Rule

Select the free warehouse which has the smallest delta from the set of free warehouses having a negative delta.

Where using the notation defined previously,

$$\Delta_i = \sum_{j \in C_i} \Delta_{ij} - F_i$$

and

$$\Delta_{ij} = \min_{k \in P_j \cap (K_1 \cup K_2), k \neq i} [\max(C_{kj} - C_{ij}, 0)]$$

Δ_{ij} represents the difference in cost between opening free warehouse k and some other free closed warehouse.

If $\Delta_i \geq 0$, $z_i = 1$ for all completions.

If $\Delta_i < 0$, a large delta implies that the warehouse is more likely to be open at the terminal node. A small delta implies that the warehouse is less likely to be open at the terminal node.

Omega Rules :

In simplification, three Omega i are computed for each free warehouse at every node. As noted, if Omega $i \leq 0$, then the warehouse i is fixed close for all branches emanating from that node. However from the warehouse whose Omega are positive, those having large Omega values are likely to be open in the terminal solution reached from this node and vice versa. This therefore suggests two more branching decision rules:

Largest Omega Rule

Select the free warehouse which has the largest omega from the set of free warehouses having positive omega.

Smallest Omega Rule

Select the free warehouse which has the smallest omega from the set of free warehouses having positive omega.

where

$$\Omega_i = \sum_{j \in C_i} w_{ij} - F_i$$

and

$$w_{ij} = \text{Min}_{k \in F_j \cap K_i} [\text{Max}(c_{kj} - c_{ij}, 0)]$$

w_{ij} is similar to Δ_{ij} , only the cost difference is computed just with respect to those warehouses which are fixed open.

Y Rules:

The optimal LP solution at a node gives fractional values of Y for free warehouse. A free warehouse whose Y is close to one will be more likely open in terminal solution reached from the node, than a warehouse whose Y is less. Conversely the warehouse whose Y is close to zero is likely to be closed in terminal solution reached from the node. This leads to two branching decision rules based on the Y's.

Largest Y Rule

Select the free warehouse with the largest Y from the set of free warehouses at the node having fractional Y.

Smallest Y Rule

Select the free warehouse with the smallest Y from the set of free warehouses at the node having fractional Y.

Demand Rules:

The rationale here is that if a warehouse capable of supplying very large demand (the sum of the demands of customers which the warehouse can supply) is closed, this would possibly result in an unfeasible node along the closed branch. If the closed branch does in fact generate an infeasible node along the closed branch, no further branching is necessary from such a node. Such a rule would therefore hopefully reduce the size of the branch and bound tree. The two branching decision rules based on demand considerations are:

Largest Demand Rule

Select the free warehouse which can supply the largest total demand from the

free warehouses at the node.

Smallest Demand Rule

Select the free warehouse which can supply the smallest total demand from the free warehouses at the node.

Khumawala tested the rule and found the largest Omega rule to perform the best and the smallest Omega to be the poorest [Khumawala 1972]. The Demand rules were generally poor performers, Largest Z worked better than Smallest Z, and neither Delta rule performed well.

Gizelis [Gizelis et al 1980] offers an interesting variant of Efraymson's [Efraymson et al 1966] algorithm in which the fixed charges are allowed to vary. Khumawala et al [Khumawala et al 1976] used branch and bound to solve a dynamic version of an uncapacitated facility location problem. Other recent work on simple facility location models is reported by Laporte [Laporte 1981], Morris [Morris 1978], and Negelhout et al [Negelhout et al 1981].

3.2.2 Uncapacitated Plant and Warehouse Location Model

Kaufman et al proposed an algorithm which solves, using branch and bound, a more general two-level distribution system requiring the simultaneous location of plants and warehouses, or warehouses of different sizes [Kaufman et al 1977]. The mathematical formulation for this simple uncapacitated plant and warehouse location model (UPW) is the following:

$$\text{Minimize } \sum_{i \in I} \sum_{j \in J} \sum_{k \in K} C_{ijk} X_{ijk} + \sum_{i \in I} F_i Z_i + \sum_{j \in J} g_j Y_j$$

Subject to

$$\sum_{i \in I} \sum_{j \in J} X_{ijk} = 1 \quad k \in K \quad (3.2.2.1)$$

$$\sum_{j \in J} X_{ijk} = Z_i \quad i \in I, \quad k \in K \quad (3.2.2.2)$$

$$\sum_{i \in I} X_{ijk} = Y_j \quad (3.2.2.3)$$

$$Z_i = Y_i \quad i \in I \quad (3.2.2.4)$$

$$X_{ijk} = 0 \quad i \in I, \quad j \in J, \quad k \in K \quad (3.2.2.5)$$

$$Y_j, Z_i \in (0, 1) \quad i \in I, \quad j \in J \quad (3.2.2.6)$$

where i, j, k index plants, warehouses, and customer respectively, and I, J, K are the corresponding sets.

This model differs fundamentally from the uncapacitated facility location in the triple subscribing and the double sets of binary variables. Constraints (3.2.2.1) are analogous to (3.2.1.1), requiring the satisfaction of the demand. Constraints (3.2.2.2) and (3.2.2.3) correspond to (3.2.1.2), assuring in the former case that shipments only originate from plants which are open and in the latter case are only shipped through open warehouses. The triple subscribing qualifies uncapacitated plants warehouse as a single-echelon model (chapter two). It is important to note that constraints (3.2.2.4) require that a warehouse be located wherever a plant is located (Factory Depot).

Kaufman et al's [Kaufman et al 1977] algorithm, which is a generalization of the work of Efroymsen et al [Efroymsen et al 1966], compute the cost reductions which would occur, relative to a particular configuration, if each of the free facilities were opened. Since facilities with positive reduced costs cannot possibly lead to an improved solution, such facilities can be locked closed in any "next lower level" completions. The ability to compute net changes in cost which will occur for all completion actions immediately lead to a lower bound completion (that is: the most optimistic outcome of opening a free facility is the cost of the current configuration, less the maximum savings which could accrue from any completion). If the lower bounds exceeds the incumbent, the node may be fathomed. Kaufman et al designed a fictitious problem in order to test the algorithm [Kaufman et al 1977]. A series of cases were run, varying the number of warehouses, plant locations, and fixed costs.

Tcha et al [Tcha et al 1984] considered the extended version of the Kaufman et al [Kaufman et al 1977] problem in such a way that all facilities should be located simultaneously for a multi-level distribution system where commodities are delivered from origin (supply) level of facilities to destination (demand) points via a pre-specified number of intermediate level facilities. They also included the dummy facilities for direct delivery. They assumed that all the facilities have unlimited capacity. Their objective was to select the optimal set of facilities to be open among the given set of potential facilities for each distribution level, which minimised the total distribution cost including the fixed cost associated with opening facilities.

They formulated the problem as a mixed integer linear programme with so-called 'tight' or 'disaggregated' constraints. They also included the dual-based procedure of Erlenkotter [Erlenkotter 1978], and Bilde et al [Bilde et al 1977] in their branch and bound. In order to make the method computationally efficient, they introduced the 'heuristic procedure' primal descent procedure which improved the integer solutions already obtained.

3.2.3 Multicommodity Uncapacitated Plant Location Model

Warszawski [Warszawski 1973] was one of the first to address multicommodity aspects. Warszawski's [Warszawski 1973] model was a generalization of (UFL) in that not only locations but commodities could be differentiated. This Multicommodity Uncapacitated Plant Location Model (MUF) has the following formulation:

$$\text{Minimize } \sum_{i \in I} \sum_{j \in J} \sum_{p \in P} C_{ijp} X_{ijp} + \sum_{i \in I} F_i Z_i$$

Subject to

$$\sum_{i \in I} X_{ijp} - 1 D_{jp} > 0 \quad j \in J, p \in P \quad (3.2.3.1)$$

$$\sum_{p \in P} Z_{ip} \leq 1 \quad i \in I \quad (3.2.3.2)$$

$$\sum_{j \in J} X_{ijp} - \sum_{j \in J} Z_{ip} \quad i \in I, p \in P \quad (3.2.3.3)$$

$$\sum_{j \in J} X_{ijp} \geq 0 \quad (3.2.3.4)$$

$$Z_{ip} \in (0, 1) \quad i \in I, p \in P \quad (3.2.3.5)$$

where p indexes commodities, and i and j index plants and customers respectively. D_{jp} is the demand for commodity p by customer j . X_{ijp} and C_{ijp} are defined as with uncapacitated facility location and uncapacitated plant warehouse location, except for the addition of the commodity subscript.

Constraints (3.2.3.1) require that demand be satisfied and constraints (3.2.3.3) ensure that customers can only receive shipments from open facilities. It is noted that multicommodity uncapacitated facility model is not in reality a multicommodity problem since constraints (3.2.3.2) limit each facility to a single commodity. This formulation was motivated by a large construction project which required the three major commodities: concrete, building blocks, and reinforcing steel. It was necessary to locate manufacturing or fabrication plants for each of the three commodities in such a way that 38 customers (destinations) could be serviced most efficiently. Warszawski's [Warszawski 1973] paper includes a discussion of a branch and bound procedure and also a heuristic. No computational results are provided for the branch and bound algorithm as Warszawski concludes that the large problem would consume excessive computer time. Results are reported on the heuristic.

Karkazis et al [Karkazis et al 1981], combined some of the concepts of Bilde et al [Bilde et al 1977] and Erlenkotter [Erlenkotter 1978], to develop two dual-based approaches for solving multicommodity uncapacitated facility model. These approaches appear to surpass Warszawski's [Warszawski 1973] algorithm computationally. Khumawala et al [Khumawala et al 1978] have devised tighter lower bounds for Warszawski's algorithm and Neeba et al [Neeba et al 1981] have suggested an efficient branch and bound algorithm for solving this problem. Robinson [Robinson 1989] considered the multi-commodity uncapacitated location problem as multi-activity commodity uncapacitated location problems (MUFLP). Robinson [Robinson 1989] justified his definition by stating that this model may be useful for a company which is engaged in a variety of distribution activities that differ in their demand pattern, customer service standards and cost structure. Robinson's [Robinson 1989] model described mathematically described in Appendix A (a1.1).

The total facility cost [Robinson 1989] algorithms exhibit an economy-of-scale of Ballou [Ballou 1981] type concave cost function in which facility cost

increase at a decreasing rate with facility throughput. In the model the cost function is piece-wise linear function composed of a fixed cost and a variable cost. By defining several facility sizes at each potential location, the economy-of-scale cost function can be more precisely approximated. Here, each facility size would have a unique piece-wise linear cost function reflecting the operating costs of the facility size. The model's solution automatically identifies the optimal facility size and associated cost function for each location. These are based on Efroymsen et al [Efroymsen et al 1966].

3.2.4 Simple Multistage Plant Location Model

Warszawski's [Warszawski 1973] also proposed some solution strategies for a dynamic version of uncapacitated facility location in which supply node locations could change over time. This multi-stage location problem, like multi-commodity uncapacitated facility location, was motivated by the large construction project application cited above. Sites for concrete mixing, the manufacturing of the building blocks, and the cutting, bending, and storage of reinforcing steel can change as the requirements for these materials differ during various stages of construction. The multi-stage single-commodity plant location model has the following formulation:

$$\begin{aligned} \text{Minimize} \quad & \sum_{i \in I} \sum_{j \in J} \sum_{s \in S} C_{ijs} X_{ijs} + \sum_{i \in I} \sum_{s \in S} b_{is} Z_{is} \\ & + \sum_{i \in I} a_{ii} Z_{ii} + \sum_{i \in I} \sum_{s \in S'} a_{is} z_{is} (1 - z_{is}^{s-1}) \end{aligned}$$

Subject to

$$\sum_{i \in I} X_{ijs} = 1 \quad \text{if } D_{js} > 0 \quad j \in J, s \in S \quad (3.2.4.1)$$

$$\sum_{j \in J} X_{ijs} \leq \sum_{j \in J} Z_{is} \quad i \in I, \quad s \in S \quad (3.2.4.2)$$

$$X_{ijs} \geq 0 \quad i \in I, \quad j \in J, \quad s \in S \quad (3.2.4.3)$$

$$Z_{is} \in (0,1) \quad i \in I, \quad s \in S \quad (3.2.4.5)$$

where

A_{is} = the installation or setup cost incurred in establishing a supply source at location i in stage s .

B_{is} = the fixed cost associated with supply source i which is independent of relocations (e.g., capital and maintenance costs).

and

s index the stage, $S = \{s\}$, and $S' = S - \{1\}$.

A distribution must be made between the two cost components defined above. The cost B_{is} is always incurred for an established source, whilst A_{is} is only incurred if the source is relocated from stage $(S-1)$ to stage S .

The objective function of multistage location systems contain the total transportation costs over all stages plus the fixed charges which are location independent summed over all stages and all open facilities, plus initial setup cost for all facilities, plus the sum of the setup costs incurred due to facilities changing location from one stage to the subsequent stage. Warszawski [Warszawski 1973] tested two methods for solving multi-stage location, an approximate dynamic programming recursion, and procedure based on highest marginal savings.

For fixed s , the constraint set (3.2.4.1)-(3.2.4.5) will be recognized as being nearly identical to that of uncapacitated facility location, the only difference being the substitution of the weaker constraints (3.2.4.2) for the tighter formulation utilizing constraint (3.2.1.2).

3.2.5 Capacitated Facility Location Model

Problems with multicommodity uncapacitated facilities model can be converted into a capacitated models by placing upper limits (capacities) on the supplies. The resulting capacitated facility location model has the following form:

$$\text{Minimize} \quad \sum_{i \in I} \sum_{j \in J} C_{ij} X_{ij} + \sum_{i \in I} F_i Z_i$$

$$\sum_{j \in J} D_j X_{ij} \leq S_i Z_i \quad i \in I \quad (3.2.5.1)$$

$$\sum_{i \in I} X_{ij} = 1 \quad j \in J \quad (3.2.5.2)$$

$$X_{ij} \in (0,1) \quad i \in I, \quad j \in J \quad (3.2.5.3)$$

$$Z_i \in (0,1) \quad (3.2.5.4)$$

Up to this point all formulations have treated the continuous flow variables (the x 's) as a measure of the proportion of total demand satisfied by the respective facilities under consideration. An important alternative formulation treats the continuous variables as units of flow; for example, redefining the

continuous variables in capacitated facility location model in term of units of flow and adjusting the cost coefficients appropriately, (CFL) can be transformed into the equivalent form:

$$\text{Minimize } \sum_{i \in I} \sum_{j \in J} C_{ij} X_{ij} + \sum_{i \in I} F_i Z_i$$

$$\sum_{j \in J} X_{ij} \leq S_i Z_i \quad i \in I \quad (3.2.5.5)$$

$$\sum_{i \in I} X_{ij} = D_j \quad j \in J \quad (3.2.5.6)$$

$$X_{ij} \geq 0 \quad i \in I, j \in J \quad (3.2.5.7)$$

$$Z_i \in (0,1) \quad i \in I \quad (3.2.5.8)$$

Constraints (3.2.5.5) prevent upper bound violations of supply for open facilities, and constraints (3.2.5.6) require that demand is satisfied. For fixed Z the capacity facility location model is reduced to a classical transportation problem and is easy to solve.

Akinc et al [Akinc et al 1977] have generalized Khumawala's [Khumawala 1972] bounding rules to the capacitated case, and additionally, have proposed a hybrid node selection rule. The node selection rule makes use of two parameters, α and β . Specifically when a node is fathomed, the next node evaluated is selected to be the one with the least lower bound (LLB). This procedure will eventually result in a large number of non-terminal nodes in

the enumeration tree. A last-in-first-out (LIFO) method generally leaves few non-terminal nodes since the node selection priority leaves few non-terminal nodes, if indicated, before backtracking to higher level nodes. Akinc et al's [Akinc et al 1977] procedure implements an LLB scheme and continues until the number of non-terminal nodes reaches the level β at which time a switch is made to LIFO to "clean up" some of the non-terminal nodes. When the number of non-terminal nodes reaches the level α (alpha), the procedure reverts to LLB.

Akinc et al [Akinc et al 1977] proposed the eight branching rule which are given in appendix A1.2. They found that the branch and bound algorithm was significantly affected by how soon nodes became capacity feasible. The bounding rules which performed best were the largest omega, largest z, largest capacity, and smallest delta.

Dearing et al [Dearing et al 1979] have reported the use of an implicit enumeration scheme to solve a bottleneck version of capacity facility location problem, in which it is desired to minimise the maximum transportation costs subject to an upper bound of fixed charges. In this variant specification of the binary variables generates sub-problems which are bottleneck transportation problems for which efficient solution procedure is known. See for example Garfinkel et al [Garfinkel et al 1972].

3.2.6 Generalized Capacitated Facility Location Model

Marks [Marks 1969] has formulated a fixed charge, distribution depot facility location problem which allows the facilities to be capacitated. The problem was that the product was to be provided in specified quantities to each of a number of demand areas from the warehouse which serve as intermediate distribution points for a number of source areas of finite supply. The problem is to determine (1) which facility should be established and (2) which supply and demand area each facility should serve. The goal was to minimise the total cost of facilities and distribution depots. The facility cost functions are

a fixed charge and a linear expansion cost. The mathematical representation is given in Appendix A1.3:

The solution technique is based on the recognition that a network algorithm may be applied to the problem. A capacitated node for each facility has been added so that a capacity constraint and a linear cost function may be ascribed to each facility location. The method begins by approximating the fixed charge cost function with the linear unit cost F_i/Q_i .

Marks [Marks 1969] started by assuming that all the facilities were open and had the approximated cost function. He solved this initial problem by an out-of-kilter algorithm. If the resulting solution is such that the flow through each of facilities is either zero or the capacity of the facility, then the optimal solution to the fixed charge problem has been found. If not, branching takes place and the facility is either included in the solution sets with its fixed charge added to the cost or excluded from the solution by setting its capacity to zero. This procedure was continued until an optimal solution is found and verified.

Geoffrion et al [Geoffrion et al 1978] have applied Lagrangean relaxation to a generalized version of a capacitated facility location problem. Geoffrion et al's [Geoffrion et al 1978] Generalised Capacitated Facility Location (GCFL) model mathematical representation is given in Appendix A1.4.

Geoffrion et al [Geoffrion et al 1978] conducted a series of test runs on an IBM 370/158 computer to compare the performances of branch and bound algorithms with and without Lagrangean relaxation as the bounding device. The bounding device used for comparative purposes was a linear programming relaxation with penalties computed from Tomlin [Tomlin 1971].

Cokelez et al [Cokelez et al 1989] also developed a warehouse capacity model

in combination with using Linear Programming and LINDO for agriculture distribution.

3.2.7 Vehicle Routing and Warehouse Location Model

If one ignores the originality of the product or the moving of a depot, the cost is minimal, eg in the paper industry, where the vehicle is being used as a depot then the routing and location problem may be considered jointly. Jacobsen et al [Jacobsen et al 1980] considered the combined problem of location and routing for distribution of a newspaper in Denmark. They stated that there are three types of decision to be made:

- i) Number and location of transfer points (in this particular case the transfer points are distribution depots);
- ii) Design of tours originating at the printing office to serve the transfer point;
- iii) Design of tours emanating from transfer point to serve retailer. They deduce that the problem is a combined location/routing and use a heuristic for solution.

Daganzo et al [Daganzo et al 1986] also considered the vehicle routing/warehouse location and employed an hybrid model as a solution.

Dynamic versions of the location-routing problem were considered by Laporte et al [Laporte et al 1989]. They presented two solutions to such problems. The first was an exact method which is appropriate for small problems. It consists of representing the problem by a suitable network and of solving optimally an integer linear programming associated with the network. In the second approach, some of the system cost is approximated and a global solution is then obtained by determining the shortest path on a direct graph. Laporte et al [Laporte et al 1989] claim that under some hypothesis this approach is suitable for large-scale problem.

3.2.8 Warehouse Location in Retailing Chain

Retail chains are also receiving attention recently as described by Rosenfield [Rosenfield 1989]. Rosenfield [Rosenfield 1989] stated that design of a distribution system for a retailing chain has a different structure from that for a manufacturing company. He pointed out the special structure of the problem due to the fixed requirements from vendors and the requirement that each customer should get all merchandise from a single distribution centre. He also stated that these assumptions hold for many retailers and some manufacturing networks and the solution to the simplified mathematical program depends on the single capacitated distribution centre. He suggested that this situation may not exist in most facility location problems. The mathematical formulation of his model is given in Appendix A1.5.

Rosenfield [Rosenfield 1989] developed an interactive package to solve the above problem. The package incorporated:

- (i) A mathematical programming solution based on the dual simplex method for the two-stage formulation.
- (ii) The capability of specifying and solving the merchandise flow for facilities located at any arbitrary input locations.

3.2.9 Multicommodity Single-Echelon Distribution System Model

Elson [Elson 1972] was perhaps the first to solve the multicommodity capacitated version of facility location problem, concentrating on a single echelon of transshipment stocking points. Elson's [Elson 1972] model recognises the management option to expand the existing facilities as well as to open new ones and the need for providing the customer service at different levels. Elson's [Elson 1972] mathematical formulation is given in appendix A1.6.

A characteristic of Elson's [Elson's 1972] model is that commodities lose their

source identity when transversing DC points. That is optimisation piece-wise plant-to-DC and then DC-to-customer. Some business applications dictate the desirability to optimise commodity flows over the entire path: that is plant to customer via DC. It appears that Geoffrion et al [Geoffrion et al 1974] were the first to solve the multi-commodity location problem as a model which simultaneously deals with location, commodity flows, and customer assignment, while permitting commodities to pass through an intermediate distribution centre (DC) en route from plants to customers. In the Geoffrion et al [Geoffrion et al 1974] model, sole-sourcing of the customer is mandatory and transportation costs are determined by the total plant-to-customer route and the distance travelled. The original model proposed by Geoffrion et al [Geoffrion et al 1974] and its mathematical formulation are given in appendix A1.7.

Geoffrion et al [Geoffrion et al 1978,1979] refined (MDS) to make it more amenable to practical application. In the revised version, sole-sourcing is only imposed on a "bundle" of similar items, not on the total demand for all items. Upper and lower limits on distribution centre throughputs are not strictly enforced and violation is allowed at a penalty cost. Lower as well as upper limits are imposed on plant capacity to enable some control over economies of scale. Throughput is computed as weighted sums of items shipped through a distribution centre with each commodity having distinct weight. And, finally, the refinements permit the unit variable cost of throughput to differ by commodity. Geoffrion et al's [Geoffrion et al 1978,1979] refinement, (MDSR) mathematical formulation is given in Appendix A1.8.

Geoffrion et al [Geoffrion et al 1978,1979] employed the decomposition theory developed by Benders [Benders 1962] for solving the stated problem. This procedure, which was first applied to distribution/location problems by Balinski [Balinski 1964], is based on separating a difficult problem into two simple problems. The problem (MDSR) is a large scale integer programming problem. How Benders decomposition reduces the level of difficulty is given

in Appendix A1.9.

Markland [Markland 1973] developed a dynamic simulation model which determines an optimum warehousing configuration within the context of a multi-product, multi-source and multi-destination physical distribution system. The mathematical formulation of the model is given in appendix A1.10.

Markland [Markland 1973] claims that his model, couched in an "industrial dynamics" framework, utilises a number of warehouses which were used by Kuehn et al [Kuehn et al 1963] and has historic relation antecedent in Shycon [Shycon 1960]. Markland's [Markland 1973] model considered the product flow and inventory levels being defined by sets of first order differences equations. The time period was considered to be only one month. The model represented the flow of product directly from manufacturing facilities to end customers, from manufacturing facilities to manufacturing facility, and from warehouse to warehouse were explicitly considered. It also allows the inventory at the manufacturing facilities and warehouse facilities.

Non-linearity was present in two major segments of the objective functions- the transportation cost associated with the various product movements and the warehousing cost associated with storage and handling at various facilities. These are the reasons he stated for simulation application. He also concluded from his study that transportation cost was a concave function of the volume of shipment through a particular warehouse. Mark [Mark 1973] stated that his model was unable to add or delete the warehouse simultaneously.

Perl et al [Perl et al 1989] classified the distribution system problem into three categories - facility location, transportation and inventory. They analyzed the interdependence between the facility location, transportation and inventory decision and proposed an integrated model for network design.

They claim that their model provides a more complete and accurate representation of the trade-offs that exist among the three cost components above, thereby leading to a solution that are closer to "true" to optimality than those provided by existing models. The mathematical expression of the model is given in appendix A1.11.

Perl et [Perl et 1989] stated that their model is different in three aspect from existing models.

- i) It represents the cost associated with all three decision components ie facility cost, transportation cost ,and inventory cost.
- ii) It represents multiple transportation options.
- iii) It explicitly represents the required level of customer service level.

Interactive Modelling

3.3 Introduction

Visual interactive models are changing the field of operational research. This is clear in the fast growing market for general purposes commercial Visual Interactive Modelling software. There are two type of visual interactive models: (i) representational graphics models, and (ii) Iconic graphics model.

A representational graphic model uses graphics to display the output of a model run. The output graphics are typically bar charts, line plots, pie charts, or other such forms of data representation. The development of a representational graphics model is, therefore, only a small conceptual step, beyond development of the mathematical model generating the statistic being displayed.

An Iconic graphic is a display that shows a system. A discrete event of

simulation is a iconic representation of real problems. Iconic graphic models may be quite different in concept from traditional mathematical models of the same system and therefore, offer a new, different, and perhaps creative look on operational research problems.

Many visual interactive models include both iconic and representational graphics, although representational graphics models are more common. What type of model is appropriate depends on the problem and its represented solution.

3.3.1 The State of Visual Interactive Modelling

Several areas of visual interactive modelling are well developed. The market leader in commercial software is visual interactive discrete event simulation with several packages available such as AWARD, SEE-WHY, FORSSIGHT, WITNESS and OPTIK. These packages produce dynamic, eight-colour iconic graphic simulation models of a broad range of system types.

Sulonen [Sulonen 1972] documents the use of graphics to build block GPSS simulation models which are then run in a conventional batch manner. Bazjanac [Bazjanac 1976] describes an animated interactive simulation which considers the emergency evacuation of people from high rise buildings using elevators, and Palme [Palme 1977] comments on the advantage of having 'moving display' generated by SIMULA simulation models. Hurrion [Hurrion 1976] developed interactive simulation and animation methods for operational and production related problems. Lapalme et al [Lapalme et al 1983] developed a visually interactive model for the school bus route and visual model for urban transportation model was developed by Babin et al [Babin et al 1982], and truck deliveries visually has been modelled by Shepard [Shepard 1983] and Fisher et al [Fisher et al 1983].

Lembersky et al [Lembersky et al 1984] developed an application technique which they describe as a decision simulator. In one of their examples a

dynamic programming formulation is used to develop an optimal forestry and tree cutting strategy. An interactive and animated graphics component was added to the model which then give a realistic training environment for the forestry staff. Bhatnagar [Bhatnagar 1983] described the location of a social service centre by using an interactive graphics model. It compares the solution generated through interactive graphics with those generated through optimisation. The author claims that the comparison demonstrated the feasibility of generating near optimal solutions for problems with certain dimensionality .

Brady et al [Brady et al 1980] whose work on a constrained minimax location problem is noteworthy as perhaps the only existing example of the man/machine optimisation algorithm for a precisely defined problem. They consider the following problem of locating a single facility in the plane to minimise the maximum distance to n existing facilities:

$$Z = \underset{x \in X}{\text{Min}} \underset{i}{\text{Max}} w_i d_i(x, A_i)$$

where

x = variable location (vector of coordinates) of a new facility;

A_i = known location of i th existing facility, $i=1, \dots, n$;

w_i = Positive 'interaction weight' of i th existing facility;

X = specified subset of R^2

d_i =Euclidean or rectilinear metric.

For $r \geq 0$, then

$$C_i(r) = \{x \mid w_i d_i(x, A_i) \leq r\} \quad i \in I$$

and

$$C(r) = \prod_{i=1}^n C_i(r)$$

It is easy to see that Z is the smallest r , such that $C(r) \cap X$ not equal to zero and that an optimal facility location x^* satisfies.

$$x^* \in C(Z) \cap X$$

Brady et al [Brady et al 1980] created a graphical interactive algorithm for this problem in which a computer is used to display X and $C_i(r), i \in I$, on a graphic display screen and a human operator observes whether $C(r) \cap X = 0$. If $C(r) \cap X = 0$, r is increased and if (not equal to 0), r is decreased and the process is repeated. Using binary search on r , an algorithm is defined that converges to the optimal value of r subject only to the fallibility of the human operator and the resolution of the graphic display device. Brady et al [Brady et al 1980] argued convincingly that these sources of error are no different from the limited accuracy with which calculations are performed in conventional computerised algorithm.

Fisher [Fisher 1986] stated that the error introduced in Brady et al's algorithm [Brady et al 1980] is by the physical characteristics of graphical display device in fact similar to computer round-off error. This error results from the fact that raster graphic scan devices use a finite, rectangular array of 'pixels' (see chapter four) to display curves so that the representation of $C(r)$ and X is imperfect and hence the Brady et al [Brady et al 1980] algorithm is subject to error. Fisher [Fisher 1986] recognise the roles played by pixel in the Brady et al [Brady et al 1980] algorithm and automated their

algorithm as follows;

Let x_{ij} , $i=1,\dots,m_h$, $j=1,\dots,m_v$ denote the coordinates of the pixel that constitute the display screen of the graphics device. Then it is no more difficult to enumerate the set $S = \{X_{ij}, i=1,\dots,m_h, j=1,\dots,m_v\}$ to find the best location within the S than it is to display X and $C_i(r)$, $i=1,\dots,n$. Specifically, this algorithm would consist of testing whether each pixel $x_{ij} \in X$ (something which must also be done to display X , see chapter four for clipping point algorithm) and if so, computing

$$r_{ij} = \max_k w_k d_k(x_{ij}, A_k)$$

The pixel in the X with smallest r_{ij} is an optimal solution to the minimax location problem computed to the same degree of accuracy attainable by the Brady et al's [Brady et al 1980] algorithm.

Glover et al [Glover et al 1985] consider the problem faced by an architect designing a building. Given a list of departments or activities that will reside within the building, the space requirement for each activity, and information of desirability of having each pair of activity close to each other, the architect must produce a space plan for the building that specifies the location of each activity.

Glover et al [Glover et al 1985] divided this task into three sub-problems, each solved through mathematical programming. At the first stage, activities are organised into clusters by solving heuristically a clustering problem. At the second stage, something called a 'bubble diagram' is created. The bubble diagram locates the centre of activities in planer representation of the floor of a building. The purpose of the bubble diagram is not to specify the exact floor layout but to locate a centre of activities in a such a way that distance

between the activities are optimal in respect to a set of weighting specified for each pair of activities that measure the desirability of having two activities close to each other. This problem is solved by a customized nonlinear programming algorithm. The third stage is to specify the exact floor layout. This problem is solved through an improvement heuristic. Graphics are used at the second and third stages to depict the bubble diagram and floor layout. This also affords the opportunity for the user of the system to modify either the bubble diagram or the floor layout produced by the mathematical programs to incorporate his own preferences.

The reason for providing interactive capabilities in this system is to cope with difficulties in quantifying aspects of this problem. The part of this problem that is difficult to quantify is the desirability of having two activities close to each other and the aesthetic aspects of a floor layout. The use of interactive graphics system allows an architect to input his crucial judgment on these issues.

Brady et al [Brady et al 1983] extended their single facility algorithm to that involving multiple new facilities. Their multiple facility algorithm was as follows:

Let J be the number of new facilities and let x_j be the location in R^2 of the j th new facility. The existing facility locations (often called points for simplicity) are denoted by A_i and the respective weights by w_i . It is assumed that each point obtains its service from the nearest new facility. Thus, given $x = (x_1, \dots, x_J)$, the cost is incurred for serving the i th existing facility is

$$\text{Min}_{j=1}^J w_i d(x_j, A_i)$$

The worst-served existing facility then has weighted distance

$$\text{Max}_{i=1}^I \text{Min}_{j=1}^J w_i d(x_j, A_i) \quad (3.3.1.1)$$

The most direct extension of the minimax philosophy of model for single facility to multiple facilities is to choose x so as to

$$\text{Min} \text{Max}_{i=1}^I \text{Min}_{j=1}^J w_i d(x_j, A_i) \quad (3.3.1.2)$$

subject to

$$x_j \in X, j=1, \dots, J$$

where, as before, X is the set of feasible locations. They wrote the condition (3.3.1.1) more compactly as $x \in X$, where X is the m -fold Cartesian product of X with itself. If the problem is considered as a network instead of on the constrained plane, then this will be an m centre problem, providing maximum service level and not maximum service level. They called the point critical (providing the maximum service) and non-critical and stated that a useful algorithm for multi-facility problem would not only have to concern itself with providing the best possible service for the critical facility, but it must also be concerned with providing good service for the other points.

They have taken the strategy of lexicographic optimisation (for more detail see Brady et al [Brady et al 1983]). In this approach, if there exist several solutions that have the worst-served point as well served as possible. If there are several alternate optima that also tie with respect to this secondary criterion, the tie is broken according to the tertiary criterion of saving the third-worst-served point as well as possible, and so on. Lexographic

optimisation as an approach to multi-objective optimisation is obviously limited to cases with massive "tying" (which is equivalent to dual degeneracy in a mathematical programming context). The multi-facility minimax location problem is evidently such a problem because there are numerous ways to locate the non-critical facilities once the critical facility(ies) is (are) located.

They considered the following very small uncapacitated problem with $m=2$, $n=4$, and suppose r has a current value such that

$$C_1(r) \cap C_2(r) \neq \emptyset \quad (3.3.1.3)$$

and

$$C_3(r) \cap C_4(r) \neq \emptyset \quad (3.3.1.4)$$

but all other pairwise interactions are empty. This interaction pattern reveals that if the two new facilities are placed such that one is in each of the non-empty intersection regions, then all four pairs will be served within weight distance r . Proceeding with the solution, it is necessary first to optimise the primary objective - that is to minimise the maximum weighted service distance. Obviously then r should be decreased to improve the worst case. As r decreases, the two intersection regions (3.3.1.3) and (3.3.1.4) will diminish to single points. That is the circle pairs $\{C_1(r), C_2(r)\}$ and $\{C_3(r), C_4(r)\}$ will each become tangent. Let t be the value of r when the first of these tangencies occurs. if $r < t$, then one of the conditions (3.3.1.3)-(3.3.1.4) no longer holds, so that it is no longer possible to have two new facilities serve all four points within weighted distance r . Therefore, t is the optimal objective function value, and the point of first tangency is the optimal location for one of the facilities. They called this facility a critical location facility. Having located the critical facility so as to optimise the minimax criterion, the second new facility can be placed anywhere within the remaining intersection region

without violating this optimal condition. With lexicographic optimization, however a best location within this region is sought for the second facility. This point can be found by deleting the two points served by the critical facility (ie the point whose circle yielded the first tangency) and by reducing the sizes of the remaining two circles until they are tangent. This point of tangency is the best location for the second facility (because it is the solution to the single facility problem for the two remaining existing facilities).

In general, the lexicographic concept is the first to locate the critical facility in the m -facility problem and then to delete all points served by this facility and solve for critical facility in an $(m-1)$ facility problem over the remaining points. The process is repeated, deleting all points served by the newly located facility and then considering the next smaller problem until all m facilities are located. Success in implementation depends on the user's ability to perceive whether or not a given intersection pattern of circles $C_i(r)$ yields an m -facility coverage of the points.

3.4 Applications Of Models

The literature abounds with examples of successful model implementations of problem-specific variants of this general class of location problems. Some of them are described below.

Drysdale et al [Drysdale et al 1969] studied the distribution of electric appliances in Canada by using heuristic techniques. They stated that using their suggested strategy, the company will save about 7 percent of its total cost.

Geoffrion [Geoffrion 1976] reports the results of a large-scale distribution warehousing location analysis for Hunt-Wesson Foods, Inc., a firm which produces several hundred distinct food products at fourteen plants and distributes these products to customers nationally through a network of twelve intermediate distribution centres in United State. The solution

technique used for analysis was Benders decomposition [Benders 1962]. Cost saving were estimated to be in the low millions.

Markland et al [Markland et al 1976] solved a large-scale multi-period planning model for a soya bean processing firm in United State.

Harrison [Harrison 1979] used a three stage stochastic programming model, which was capable of handling the fluctuating demands. He described a successful study for a pharmaceutical company in Ireland. On implementation of proposed the strategy for distribution system network the delivery cost has been reduced by 23.3% and transport cost by 20%.

Van Roy et al [Van Roy et al 1980] report impressive results in the design of a large-scale single commodity single-echelon problem for a company which distributes a bottled product. The problem solved is a capacitated plant location problem with some special linear side constraints. The approach used was a variant of Erlenkotter's [Erlenkotter 1978] dual ascent method imbedded in a branch and bound scheme. All capacity constraints were relaxed and the dual ascent method was used to solve the relaxations.

Jacobson et al [Jacobson et al 1980] solved simultaneous vehicle routing and depot location problems for a large newspaper firm in Denmark.

Geoffrion et al [Geoffrion et al 1981] developed a Management Support System for the R&G Sloane Manufacturing Company. They used the support system for production and sales planning. The system is credited with an increase of 13% in operating profits during a recent year.

Kochman et al [Kochman et al 1981] demonstrated how the formulation of a model can impact solution efficiency. These authors solved a planning problem concerned with the optimum placement of communication cables, and the routing of individual circuits between demand points (both satellite and

cable) such that total discounted cost over the T-period horizon is minimized. This is a multi-period capacitated distribution/location problem with some complicating side constraints which specify, for reliability purposes, a minimum network diversity. Two formulations emerge: facility diversity and routing diversity. The routing diversity problem is significantly smaller than the facility diversity problem and can be more efficiently solved. The method actually used for solving the facility diversity model was based on relaxing some of the coupling constraints and using the efficient code developed by Chen et al [Chen et al 1977]. This procedure reduced the solution times for the facility diversity problem, and the first solutions were not more than 12% from optimum.

Gelders et al [Gelders et al 1981] used a heuristic to locate processing plants and collection stations and to solve the associated vehicle routing problem for latex product in Malaysia. Blumenfeld et al [Blumenfeld et al 1987] describe a successful case study for General Motors in North America by using a TRANSPART (II) (see chapter 5). They stated that their decision support system has been used at over 40 General Motors facilities and saving at different facilities very widely with documented examples ranging from \$35,000 to \$500,000 per year per application. Rosenfield [1988] describes a successful case study for locating a distribution centre in retailing network.

Successful applications of visual interactive simulation were reported for a large scale drinks warehouse by [Saw et al 1989]; production planning [Hurrion 1976]; queuing systems analysis [Crookes et al 1982]; personal training [Lembersky et al 1984]; job shop scheduling [Hurrion 1978]; traffic flow analysis [Kaufman et al 1981]; and assembly-line design [Fiddy et al 1981, Garbini et al 1983].

A geographically based decision support system has been developed to help Southland corporation traffic managers choose route for trucks that deliver

to convenience stores [Belardo et al 1985]. The system, implemented on a microcomputer, presents information on routes and accounts, uses flexible computer graphics and interactive text screens to help a traffic manager analyze routes and produces maps for drivers and reports for management.

Glover et al [Glover et al 1979] developed and implemented a decision support system for the Agrico Chemical Company. They used a support system to integrate computer-based production, distribution and inventory. The system is used extensively to evaluate the benefit/cost impact of alternative capital investments. According to Agrico management, up to 1981 it had saved over \$40 million dollars.

Bender et al [Bender et al 1981] developed a general purpose decision support system for international paper to help make resources allocation decision. The scope includes actual, operational and strategic planning from the woodlands, through all the intermediate processes and the distribution of finished primary and by-products. The system has identified significant cost improvement opportunities. In addition, the system has been quoted as substantially reducing the level of contention surrounding resource allocation decisions.

3.5 Conclusion

It will not be a overstatement to say that this is a most comprehensive review of logistic strategy modelling literature. The visually interactive models have the advantages of making visual impact, but they are not useable to model the complex logistics systems.

The reviewed mathematical models are capable of modelling any complex logistics systems, but one cannot see what is happening; only the computer print-out is available.

The visual interactive models provides the combined power of visual and

mathematical models for logistics systems but no one has yet produced a meaningful model for logistics systems. Perhaps this task may be accomplished by this dissertation.

Chapter Four

State of the Art in Computer Graphics and Cartography

4.0 Introduction

In this chapter, the state of the art in cartography and computer graphics systems will be discussed. The discussion will be limited to those techniques which are used in the LSM to achieve the defined objectives.

4.1 A Brief History of Computer Graphics

The computers of 1940's used primitive hard-copy devices requiring users to sift through reams of alphanumeric printout. The Whirlwind computer, built in 1950 at MIT (Massachusetts Institute of Technology) to investigate aircraft stability and control, was probably the first to use a cathode ray tube (CRT), or television-type display. Prior to this computer designers had not thought of connecting this common display device to computers. What prompted the marriage was the desire to speed up the interaction between user input and computer output.

The SAGE (Semi Automatic Ground Environment Air Defence System), introduced by the US government in the mid 1950s, provides the first example of a production system that relied on the use of interactive computer graphics. The father of real time interactive computer graphics is Sutherland [Sutherland 1963]. Sutherland's doctoral dissertation "Sketchpad", a man-machine graphical communication system, was the most influential of early works in computer graphics. It presented in embryonic form a methodology for computer graphics which give the subject its name and began its evolutionary development. Sutherland's display had a resolution of 10 bits per axis and lines were displayed as a series of discrete dots. Interaction with the drawing was achieved with the aid of the light pen developed earlier by Gurley and others [Gurley et al 1959].

SKETCHPAD [Sutherland 1963] could provide rubber band lines in which the

computer would track the light pen and draw a straight line from the last specified point to the position of the tracking cross. This give the affect of a rubber band as the light pen was moved. A circle could be drawn by specifying the centre and its radius and could, in turn, be used to constrain the drawing of a polygon within it. Once the polygon had been created, the circle could be deleted. Commands were input using buttons, such as "circle centre", "move" and "delete", and most of the construction was provided by the straight edge and compass which "were available in highly accurate form".

The early CRTs had the ability to draw a straight line between any two points on the display screen. However, since a line faded very quickly on the screen, it had to be redrawn many times a second. In the early 1960s, this required expensive memory in which to store the line endpoints and expensive hardware with which to rapidly redraw the line. In 1965, IBM (International Business Machine) introduced the first mass-produced CRT of this type. A price tag of over \$100,000 for the CRT alone deterred many computer users from entering the field of graphics.

In 1968, Tektronix introduced storage-tube CRTs, which permanently retain a drawing until the user erases it. These displays eliminated the need for costly memory and a hardware redrawer. A \$15,000 selling price made them the preferred display screen for approximately the next five years.

The mid-1970s marked the beginning of a period of dramatic reductions in the cost of both memory and hardware logic units. These reductions led to the current proliferation of memory-intensive raster-scan displays. These displays are used to produced realistic-looking, shaded and coloured images and maps in an interactive environment. The prices of graphics systems versa time is depicted in figure 4.1.

So far the role of hardware in the development of computer graphics has been examined. However, software also played a crucial part in its development.

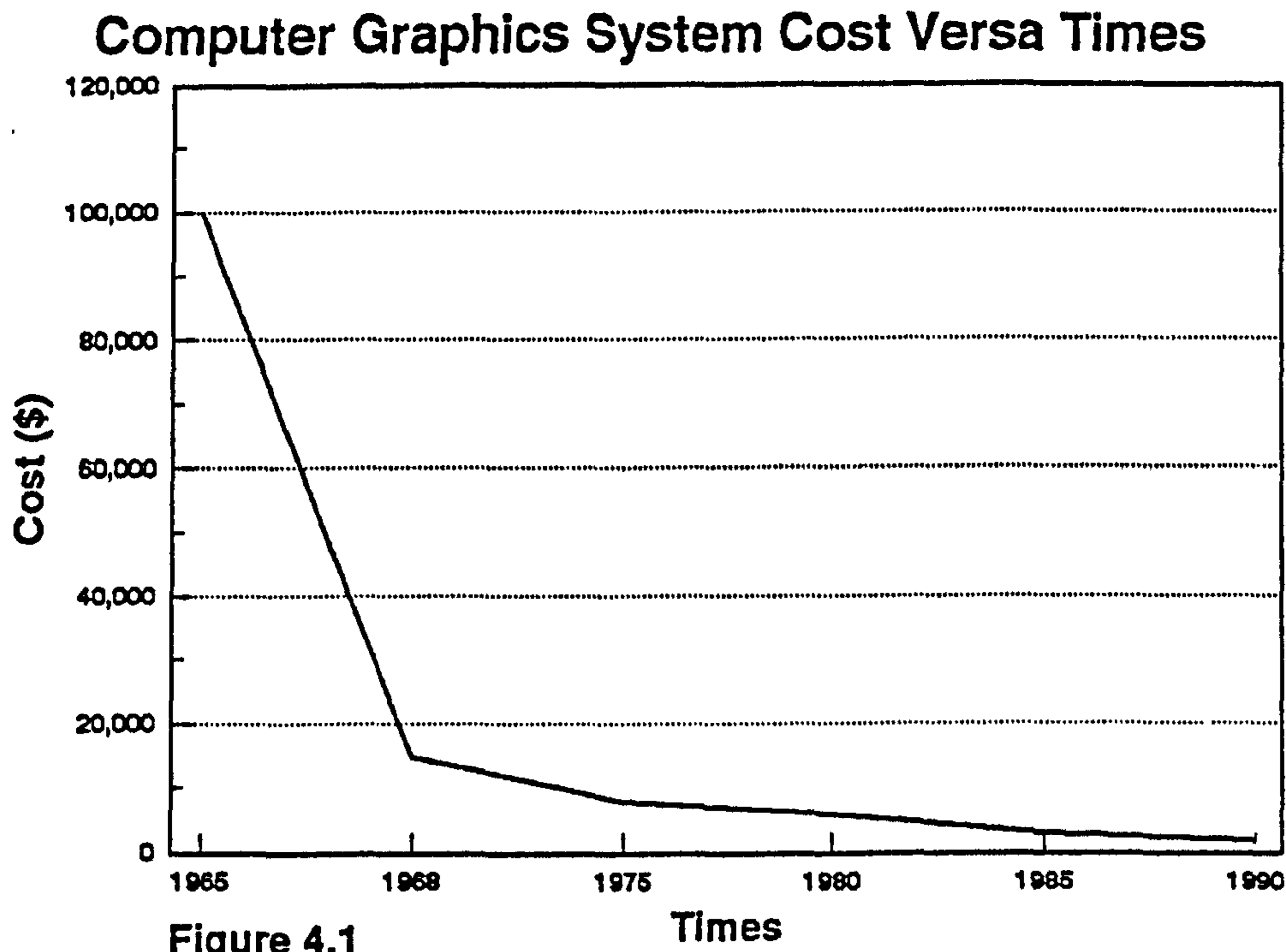

In this field too Sutherland [Sutherland 1963] was the early leader. He designed some of the major algorithms and data structures on which computer graphics is based. The pioneering works of Coons [Coons 1963, 1966] and Bezier [Bezier 1972] with curved surfaces, led the way to the interactive computer generation of realistic three dimensional images. Over the last twenty years many people have developed important algorithms that are used in computer graphics.

4.2 Hardware

A typical interactive computer graphics system has four components: a computer, a video display screen generator, user input devices and hard copy output devices. The objective of this section is describe the input and output devices which are used in LSM. Since LSM displays the information graphically, and graphics output depends on the output device, the techniques used by each device to display or print the image will also be described.

4.2.1 Input Devices

The user of an interactive graphics system communicates with the graphics program by means of input devices. These devices provide the natural dialogue between the user and the program. The effectiveness of an input device should be judged against the following criteria suggested by Keast:

"It must be simple and natural to use, requiring little or no operator training. The interface between input device and computer should be simple. Support software must be minimised so that maximum core storage may be dedicated to display control. The device and its interface should be inexpensive, versatile and capable of interaction with different types of display. The provision of hard copy or the facility of touch interaction without a special stylus may be considered essential to the user situation."

[Keast 1967]

Taking Keast's view into consideration, the user of the logistics strategy model can communicate with the program by means of keyboard and mouse.

4.2.1.1 Keyboard

The most familiar input device is the keyboard. It is primarily used to enter the program and data into the computer. Whenever a key is pressed, a unique character code is transmitted to the computer. There are 128 (ASCII) codes each of which can be used to elicit a different response from the graphics program. The logistics strategy model is setup for UK keyboards under the MS-DOS operating system. For further information on which key is used for which instruction, see the user manual.

4.2.1.2 Mouse

The Mouse was developed at the Stanford Research Institute [Prince 1971]. It is a hand-held device that takes advantage of the user's natural eye-hand coordination. It enables the user to locate and chose an object on the display screen accurately and comfortably. LSM employs the mouse for modification

of the system.

There are also other devices that can be used for inputting data such as Paddle, Joystick, lightpens and digitizers. It was considered that these devices would not increase the user friendliness of LSM. Therefore these devices are not employed to communicate with model.

4.2.2 Output Devices

There are two type of output devices, soft copy output devices and hard copy output devices. Soft copy output devices include monitors and hard copy output devices include all the different types of graphics printers and plotters.

4.2.2.1 Soft Copy Output Devices

LSM is able to utilise most of the soft copy output devices for graphics display. The output devices that will be discussed in this section are video display generators, raster scan displays, storage tube displays, and liquid crystal displays.

4.2.2.1.1 Video Display Generation

Most video display screens are the same type of cathode ray tubes (CRT) that are used in home television sets. The electron gun contains a cathode that when heated emits a beam of negatively charged electrons towards a positively charged phosphor-coated screen. Along the way, the electron beam passes through the focusing and deflection system, which consists of an electrostatic or magnetic field.

The focusing system concentrates the beam so that by the time the electrons reach the screen, they have converged to a small dot. The deflection system, which consists of two pair of deflection plates (horizontal and vertical), directs the electron beam to any point on the screen. Both pairs have equal voltage but opposite charges. When a negative charge electron passes through the plates, it is attracted to the positively charged plate, resulting in a deflection

of the electron. The degree of deflection depends on the voltage on the plate. By varying the voltage on the horizontal and vertical plates, the electron beam can strike any point on the screen.

When this focused electron beam strikes the screen, the phosphor emits a spot of visible light whose intensity depends on the number of electrons in the beam. A blank spot on the screen corresponds to no, or very few, electrons being sent to that spot. The light on the display screen starts to fade as soon as the beam moves to another location. The time the light remains visible depends on the type of phosphor coating the screen. Normally, a visible light lasts a fraction of a second. In order to give viewer the appearance of a continuous, flicker-free image, each illuminated dot on the screen must be intensified many times per second. This type of video display is called a refresh CRT. Two types of refresh CRT are available: raster scan and random vector. Although both are currently in use, the raster scan system is preferred for most microcomputers and for applications that require colour and shade. A colour CRT has three electron guns, one for each of the three primary colours, red, green and blue. A delta-gun system arranges the shadow mask placed between the guns and the face of the display screen. Each pixel is composed of a triangular pattern of a red, green, and blue phosphor dots. The holes in the shadow mask are aligned so each electron gun excites its corresponding phosphor dot.

4.2.2.1.2 Raster-Scan Display

The video display screen used by most microcomputers is divided into very small rectangular dots. These dots are called pixels. CRT screens consist of a grid of vertical and horizontal lines of pixels. The horizontal lines are called raster scan lines and the video display is referred to as a raster scan display. The quality of a raster scan display is often described in terms of its resolution. The greater the resolution, the greater the detail of an image can be.

4.2.2.1.2.1 Frame Buffer

Each screen pixel corresponds to a particular entry in a two dimensional array in the memory. This memory is called frame buffer or bit map.

4.2.2.1.2.2 Display Controller

This hardware device reads the contents of the frame buffer into a video buffer, which then converts the digital representation of the string of pixel values into analog voltage signals that are sent serially to the video display screen.

4.2.2.1.3 Storage Tube Display

A direct view storage tube (DVST) is the most popular storage tube [Newman et al 1973 and Stadtfeld 1968]. It is a CRT display that does not need to be refreshed from memory. A storage surface area is situated behind a long persistence phosphor display screen. As the electron beam strikes the storage grid, a positively charged pattern is created. A second electron gun, called a flood gun, continually emits low-energy electrons that uniformly cover the entire screen. These electrons cause the positively charged stored image to be transferred to the phosphor screen and remain visible for up to one hour. The stored image is erased by giving the entire storage grid a positive charge.

The advantages of a DVST include high resolution and non staircase like lines combined with a flicker free image. Its major disadvantages include the lack of selective erase and dynamic update facilities. Each change of the image requires the entire image be erased and redrawn.

4.2.2.1.4 Liquid Crystal Display

Liquid crystal display (LCD) consist of two glass plates that are separated by an organic conductive liquid crystal. Electrical charges convert the liquid back and forth from a visible to an invisible state. Medium-resolution displays have a single display that is divided electrically into a number of smaller displays that are displayed simultaneously. The major advantages of LCD screens are

portability and low power requirements. Their disadvantages include the lack of grey scale and colour.

4.2.2.2 Hard Copy Output Devices

LSM output is in graphics format. It supports most of the hard copy output devices such as graphics printers and plotters.

4.2.2.2.1 Dot-Matrix Printer

A dot-matrix printer is an inexpensive device that produce low to medium-quality graphics output. The movable print head has a column of pins that can be pressed against the paper by small electromagnets. Each pin selected produces a dot on the paper corresponding to a lit screen pixel. The resolution of dot-matrix printers ranges from 10 to 20 dots/in.

4.2.2.2.2 Ink-Jet Printer

An ink-jet printer uses electrical impulses to project drops of ink onto the paper as the print head move across the page. It ejects up to 12 ink drops at each specified point. Ink-jets produce high-quality shaded and colour images with resolution of up to 200 dots/in.

4.2.2.2.3 Point Plotters

Point plotters produce images by moving the pen between two given points on the paper.

4.2.2.2.4 Electrostatic Plotters

Electro-static plotters are raster plotters that can produce high quality colour images with resolutions as high as 200 dots/in. Electrostatic dots are placed on the paper as the paper moves over the fixed writing head.

As previously described, LSM is able to use most of the soft and hard copy output devices. The system presently uses IBM AT and compatible hardware and a dot-matrix printer.

4.3 Software

The software for a computer system is as crucial as the hardware. The software is not able to function without the hardware and vice versa. In this section details of the employed graphics system "Halo" will be provided. The various software-defined graphics coordinate systems are explained. Software techniques such as viewports, transformation and clipping are also discussed.

4.3.1 Graphics System Software

Graphics software is a fundamental component of any graphics displaying system. Systems with most sophisticated and expensive hardware devices would be ineffective for most people if they did not have high performance, user-friendly software. The graphics software allows the programmer to design the graphics routines independently of the displaying system. A major drawback of many previous graphics systems was that they were machine specific. Different programming languages, such as Fortran, C, and Pascal, are easily interfaced with graphics software.

There are many software packages in the market. In this section only HALO's features and powers will be discussed because it was used to develop the logistics strategy model.

HALO, with its many device drivers, can be interfaced with a wide variety of graphics display, input and hard copy devices. It allows users to write applications that can be configured dynamically at run time to a large number of different computer graphics environments.

It also has facilities for both bit-mapped and stroke text, lines, circles, polygons, area fills, line styles, crosshair cursors, and device, normalized device and world coordinate systems.

HALO provides for window management through the use of

viewports. In addition to simple graphics functions, it provides support for palette control and image digitizing on boards which support these functions. It also has a display list facility that can be used to generate files of vector based devices.

When performing the clipping HALO will calculate the slopes, arcs, etc. This treatment of clipping allows images (in this context any object displayed on the screen is known as an image) to be scaled and moved about the display surface without consideration of physical boundaries. Clipping of text is performed on character boundaries. A character will not be displayed if any part of it extends beyond the display boundaries.

LSM is able to run on different graphics cards such as Hercules, CGA (colour graphics adapter) and EGA (enhanced graphics adapter). At present it uses an EGA graphics card for its output display. The EGA has 64 colours but HALO is able to display only 16 of them.

However, HALO does not support a character window. A character window is a facility which enables the user to communicate with a system while a program is running in a graphics mode. This facility is particularly important for a system like LSM, because most of the database file names are entered from the keyboard. All the modifications are carried out by using a keyboard.

Nor does HALO support a mouse device. Therefore two subroutines were written in machine code to enable the user to communicate with LSM by using the keyboard and mouse. This made HALO an ideal graphics system to be used in the development of LSM.

Summary of HALO:

HALO is a comprehensive library of graphics subroutines. It is the most widely used graphics library under MS/DOS. HALO's extensive library

provides functions such as points, lines, arcs, circles, ellipses, hatch styles, and pattern fills. Colouring control functions are available for colour selection, palette management, dithering and textures. Advanced features include scalable fonts, world coordinates, polygon curve fitting, image compression and display list processing. Line width, size, angle, filled and unfilled characters can all be specified. HALO is written in Assembler language and can be called from all the higher level languages, including Basic, C, Fortran, Pascal and Lisp. HALO also includes a virtual rasterization interface (VRI) which frees users from the limited resolution of their graphics board by modelling the graphics display in memory and permitting users to produce hard copy to the maximum resolution of the output device.

4.3.2 Coordinate System

Coordinates provide a way to access a given pixel. Each pixel on the screen may be manipulated by using its own unique "address". There are three types of coordinate system being used in the computer graphics industry. These are the device, normalized device and world coordinates systems.

4.3.2.1 Device Coordinates

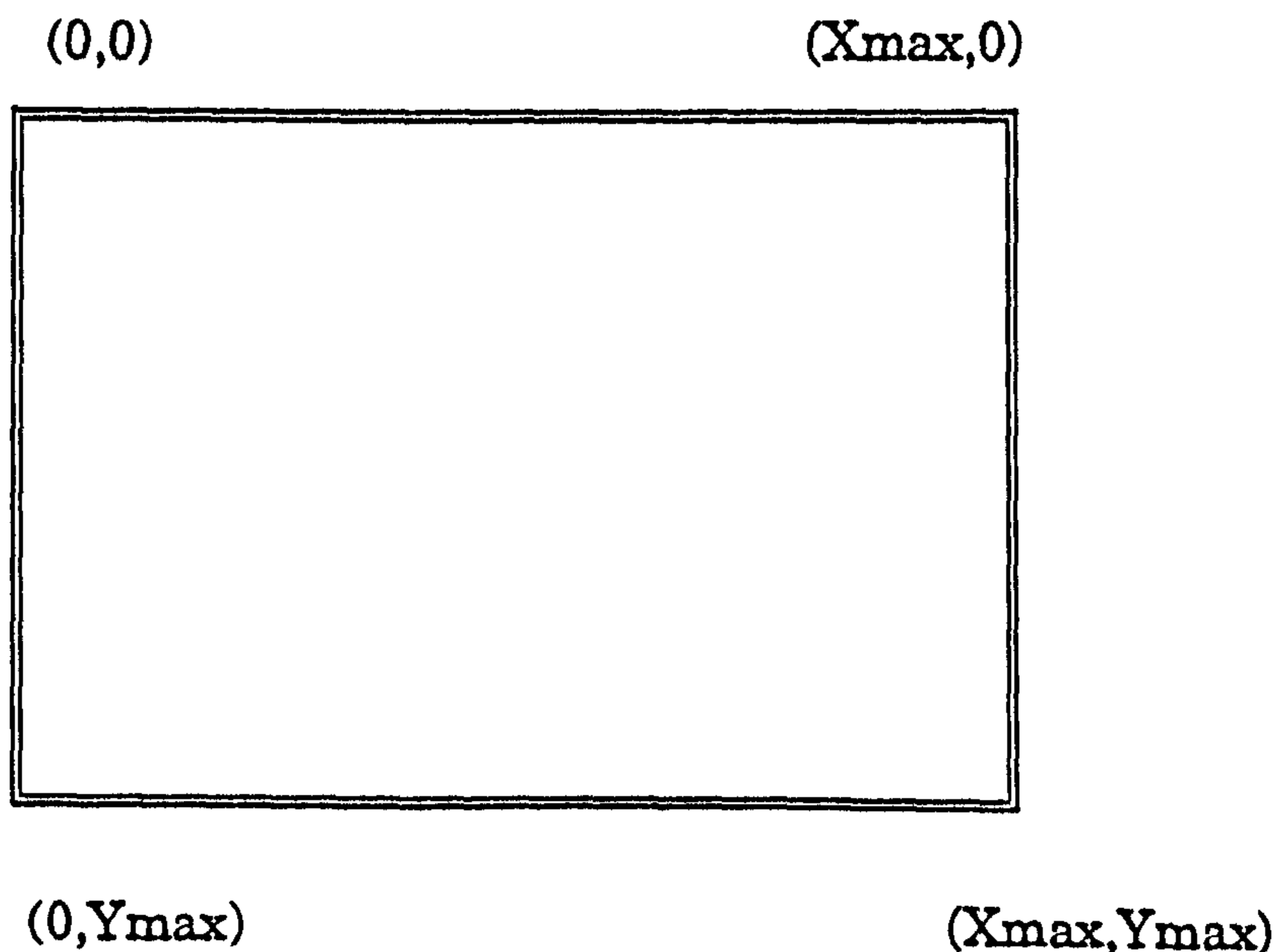

Figure 4.2

Device coordinates are precisely that: coordinates based on a particular device. Device coordinates vary according to the resolution of the device. The upper left corner of this screen is at coordinates (0,0) and the lower right hand corner has the maximum value of X and Y as depicted in figure 4.2. When device coordinates are used, the upper left hand corner is always (0,0). Device coordinates are always integers. LSM uses these coordinates when zooming facilities are being used and rubber bands are in action.

4.3.2.2 Normalized Device Coordinates

Normalized device coordinates provide a device-independent coordinate system. Whereas with device coordinates it was necessary to know the resolution of the graphics device, the normalized device coordinate system allows the programmer to address all devices without knowing the resolution. The normalized device coordinate system converts the screen resolution down to real a number between 0 and 1.

The upper left hand corner is still referred to as (0,0). The lower right corner of any graphics device will always be referred to as (1.0,1.0) when using the normalized coordinates as depicted in figure 4.3. The graphics system HALO provides the necessary "mapping" of the normalized device coordinates to device coordinates and back again. Normalized device coordinates are always floating point numbers.

4.3.2.3 World Coordinates

The world coordinates system is very similar to the normalized device coordinate system. Whereas the normalized device coordinate system "mapped" the device coordinates to a real number between 0.0 and 1.0 , the world coordinates system works on a user specified range. The position of the (0.0, 0.0) has changed to the lower left hand corner (figure 4.4). The position of (0.0, 0.0) may be changed to any of the four corner by changing the range of the world coordinates. It is important to appreciate that using the world

coordinates system the graphics device may be "mapped" to any specified range. The world coordinates are always used in LSM except when screen coordinates are in action. World coordinates are always floating points.

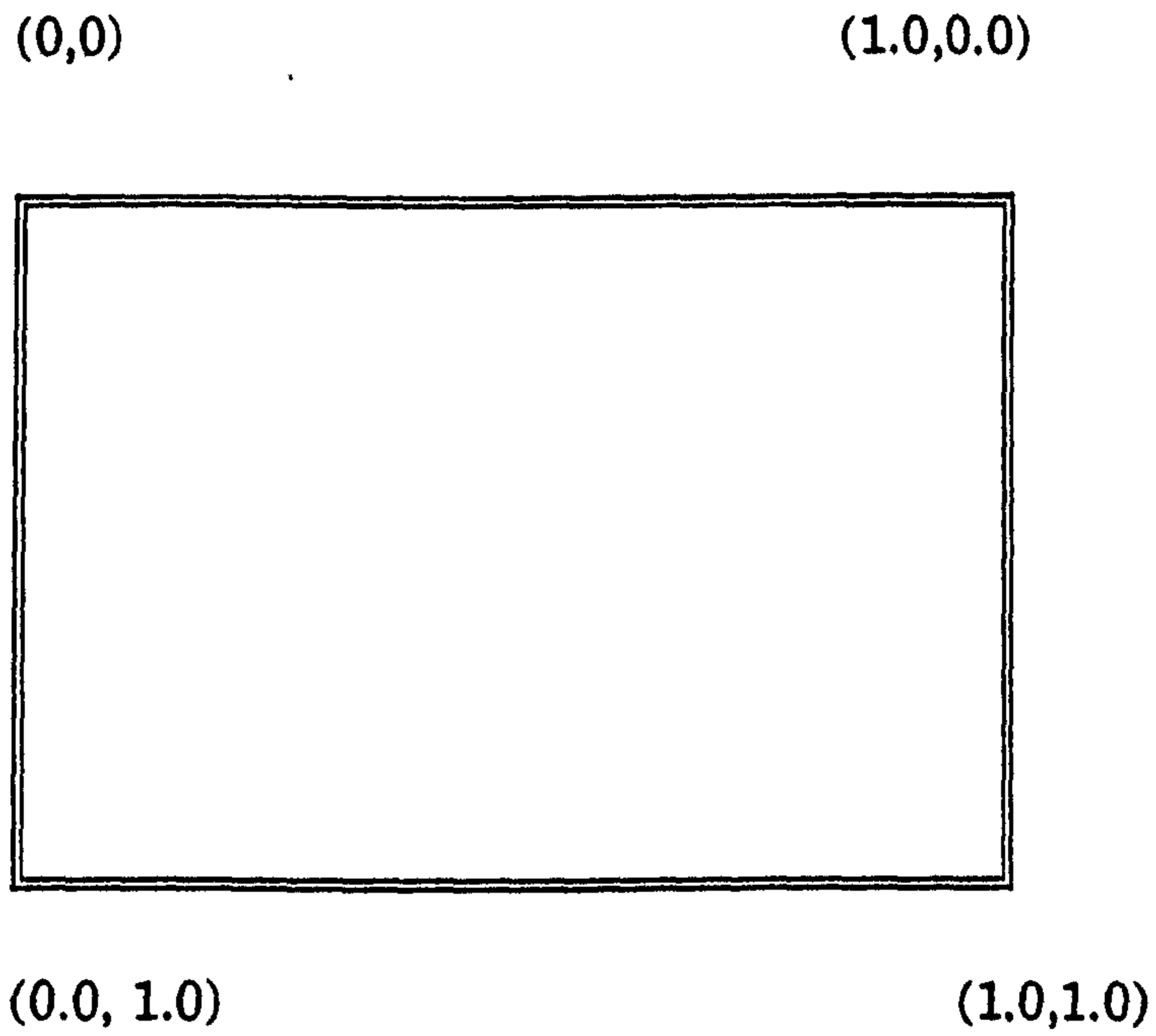

Figure 4.3

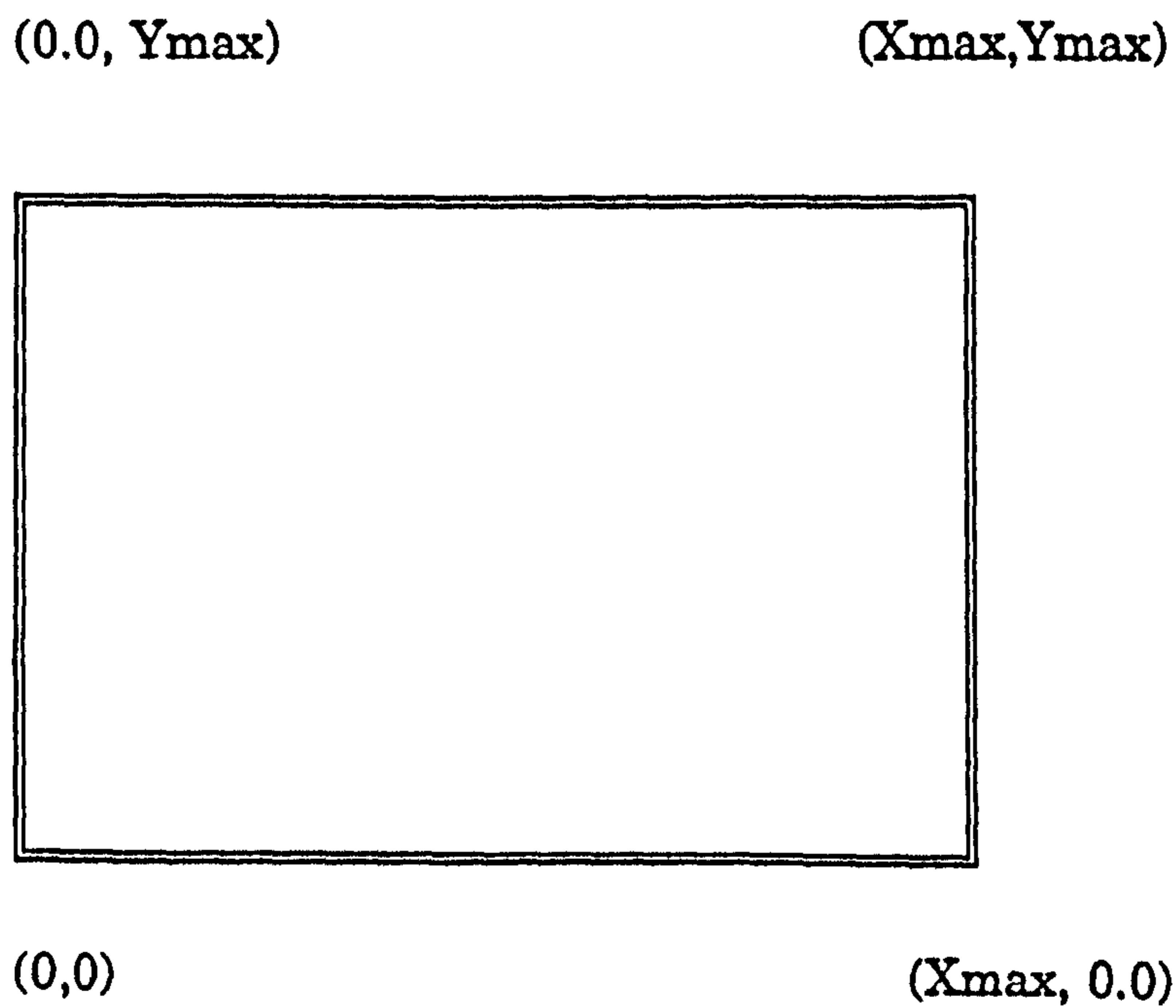

Figure 4.4

4.3.3 Viewports

Viewports is used when only a portion of the screen is used to display the graphics image, in contrast to world coordinate in which the whole screen is used to display the image. A typical division for a computer screen is depicted in figure 4.5. It is important to note that the upper left corner and the lower right corner of the Viewports are specified using normalized device coordinates. In Halo's system viewports only work when normalized device coordinates are used. However the Viewports windows' coordinates can be defined by using world coordinates.

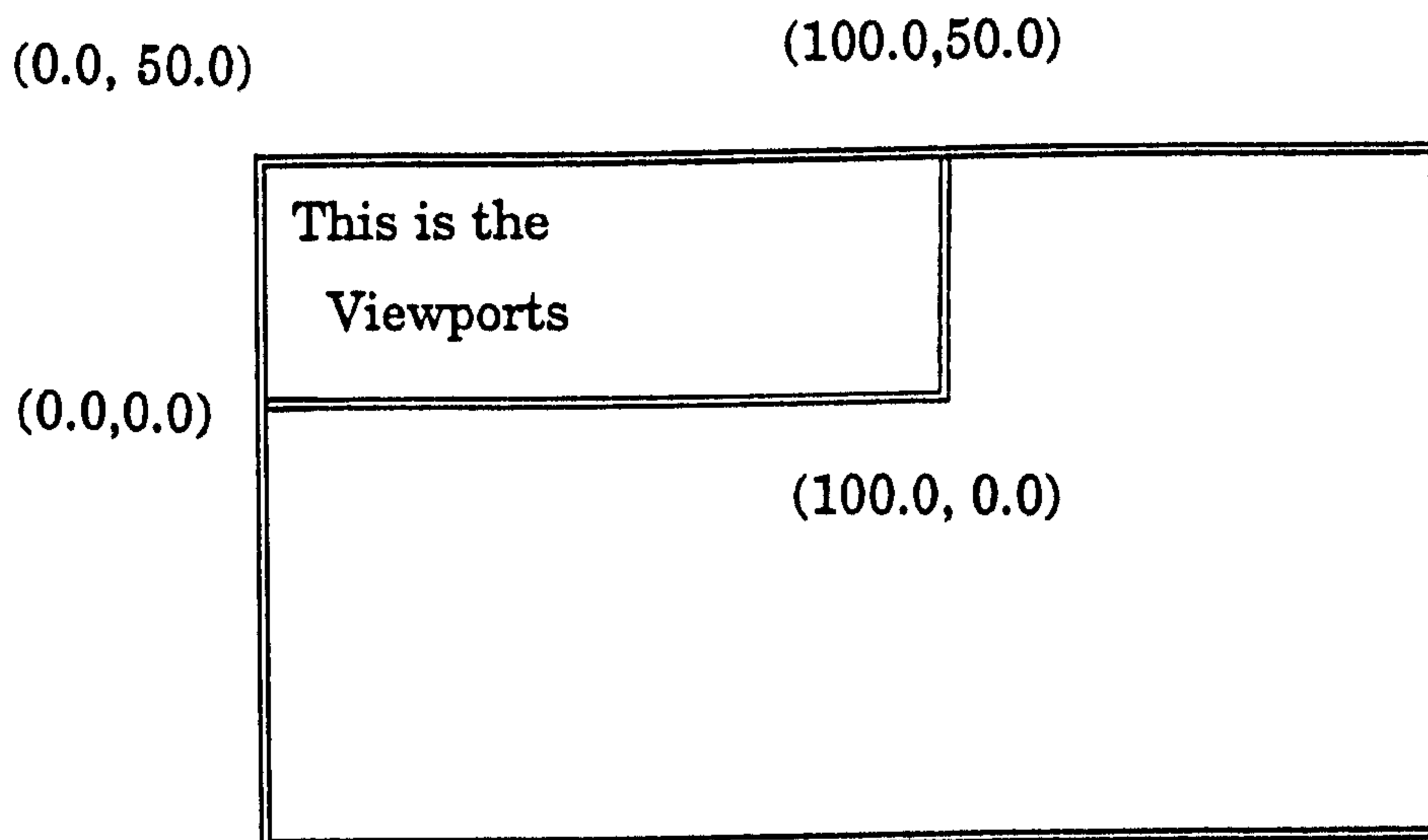

Figure 4.5

4.3.4 Transformations

The transformation is a function which is employed to translate or rotate or scale the graphics image. Two transformations can be combined, or concatenated, to yield a single transformation with the same effect as their sequential application. Thus transformation A might be a translation and transformation B a scaling. The concatenation property allows us to determine a transformation $C = AB$ whose effect is to translate and then scale.

In order to scale, move or rotate a picture, the matrix operations are applied to the coordinates defining the shape. Matrices are a natural mathematical technique for manipulating shape coordinates. Each of the matrix operations literally transforms a point (X,Y) into a new point (X1,Y1). As any shape can be considered a set of points and vectors, an entire shape can be transformed point by point before being displayed.

Rotation and scaling are matrix multiplications as translation is a matrix addition. It would be preferable if all three operations could be applied as a matrix multiplication. This would allow all transformations to be treated in a uniform way. The usual method of accomplishing this is to extend the shape coordinate into homogeneous coordinates (the homogeneous representation of an object in n-space is an object in (n+1)-space; the n-space representation is in ordinary coordinates, that in n+1-space is in homogeneous coordinates). This involves changing the 2*2 matrix into a 3*3 matrix. The addition of an extra row and column provide a simple tool by which the transformation can be treated in a consistent manner. The third element in the expression (X1,Y1,1) corresponds to a third plan Z. If (X,Y,1) are homogeneous points, performing the above operation on them will form the new points (X1,Y1,1). The matrices' operation may be performed as follows:

Translation =

$$[X1, Y1, 1] = [X, Y, 1] \begin{bmatrix} 1 & 0 & 0 \\ 0 & 1 & 0 \\ T_x & T_y & 1 \end{bmatrix}$$

Rotations

$$[X_1, Y_1, 1] = [X, Y, 1] \begin{bmatrix} \cos \theta & -\sin \theta & 0 \\ \sin \theta & \cos \theta & 0 \\ 0 & 0 & 1 \end{bmatrix}$$

Scaling

$$[X_1, Y_1, 1] = [X, Y, 1] \begin{bmatrix} S_x & 0 & 0 \\ 0 & S_y & 0 \\ 0 & 0 & 1 \end{bmatrix}$$

LSM does not utilise the rotation of displaying objects in its graphics operations. However HALO does not support the zooming function (zoom in or zoom out). Zooming is achieved by using the scaling technique on map displaying coordinates and on other displaying object coordinates such as factories, depots and customers.

4.3.5 Clipping

Clipping is used when the whole picture does not need to be displayed on the screen, as during zooming operations in LSM. There are different clipping algorithms which affect three types of information, points, lines and polygons display. Only points and lines clipping will be discussed here as they are used the ones used in LSM.

4.3.5.1 Points Clipping.

The points algorithm is very simple. If a point (X,Y) is visible it must satisfy

the following conditions:

X is greater than X_{min} and less than X_{max}

Y is greater than Y_{min} and less than Y_{max} ,

where X_{min} and Y_{min} are minimum coordinates values of the windows and X_{max} and Y_{max} are maximum values of windows coordinates.

4.3.5.2 Lines Clipping

There are three possible types of lines to be considered for zooming: a) Those that are completely visible; b) Those that are completely invisible; and c) Those that are partially visible. For an algorithm to be efficient it must be able to determine (a) and (b) very quickly. The third type (c) is trickier, because it really refers to two lines; those that are definitely partially visible and those that are really invisible but are very difficult for any algorithm to treat immediately as invisible.

LSM utilises the points and lines clipping algorithm in a zooming mode. Before displaying a point, it checks whether a point is located inside or outside the zooming window. For a line clipping it checks that both sides of the line are either inside or outside the zooming window. The working of zooming functions in LSM is described in chapter seven.

4.4 The State of the Art in Cartography

In this section discussion will be confined to those techniques of cartography which are employed in LSM. The section starts by describing the shape of the earth and includes the earth's geographical coordinates (latitude and longitude). It also discusses map projections and their effects on angles, areas, distance and scales. The different projections and their advantages and disadvantages are also discussed.

The shape of the earth is important for any logistics model which employs a visual interactive technique for modelling a logistics system. The earth is a spherical and is being modelled on a two dimensional computer screen. This

will obviously result in a distortion of its shape.

Latitude and longitude are discussed because they are used in distance calculation. It is also important to understand the effect these coordinates have on distance by their position on the earth's surface.

Map projections, and variables that are affected by projections, such as angles, distances, and areas, are described. Different projections are discussed to understand their advantages and disadvantages and the reasons for utilising a particular projection in LSM is explained.

4.4.1 Shape of the Earth

The earth is spherical and the simple way of mapping it without distortion is to project it in same form on the computer screen. All that has been changed is the size (scale); relative distances, angles and areas remain the same. A globe model, however, is difficult to produce on a two dimensional screen and is of limited use in logistics study as only half of it is visible at any time. The globe's drawbacks can be overcome by developing the map on to a two dimensional computer screen. The construction of a map on a flat computer screen requires an important operation in addition to the altering of scale. The spherical surface must be transformed to a plan (flat) surface. The system of transformation in computer graphics is called map projection in cartography. Before map projection is discussed it is important to describe the coordinates which make up maps, how they are derived and what they represent.

4.4.1 Geographical Coordinate

On a motionless spherical surface there would be no natural starting point. But the earth rotates on an axis and orbits the sun in a regular habit. The position of the other celestial bodies are thus predictable and location can be calculated if one has some means of telling the time and an ephemeris (an astronomical almanac containing tables that list daily apparent positions of

celestial bodies). The geographical coordinate system was devised to make possible a statement of location relative to the two points where the axis of the earth's rotation intersects its surface. Specifying a location on the earth requires the determination of a north-south distance, called latitude, and an east west distance called longitude.

4.4.2 Latitude and longitude

4.4.2.1 Latitude

The system of locating a point in a north-south position depends on the regular curvature of the earth's surface. A latitude may be defined as an angle between a normal (perpendicular) to the surface and the plane of the equator at that place. The ancients imagined an infinite number of circles around the earth parallel to one another as depicted in figure 4.6. The one dividing the earth in half, equidistant between the poles, was named Equator. The series north of equator is called north latitude, and the series south of the equator is called south latitude.

Because the earth is not a true sphere but an oblate spheroid (flattened in the polar areas), the quadrant from the equator to a pole is not a true arc but curves less rapidly near the pole. The latitude of a point (geographic or geodetic) is the angle between a perpendicular to the surface and to the plan of the equator. It follows that near the poles one must move a greater distance on the earth's surface compared to near the equator to observe a change of one degree. Consequently degrees of latitude are slightly shorter near the equator (68.7 mile or 110.6km) than near the poles (69.4 mile or 111.7km).

4.4.2.2 Longitude

The east-west distance is provided by an infinite set of great circles called meridians and arranged perpendicular to the parallels. Unlike the equator in the latitude system, no meridian is a natural starting line from which to

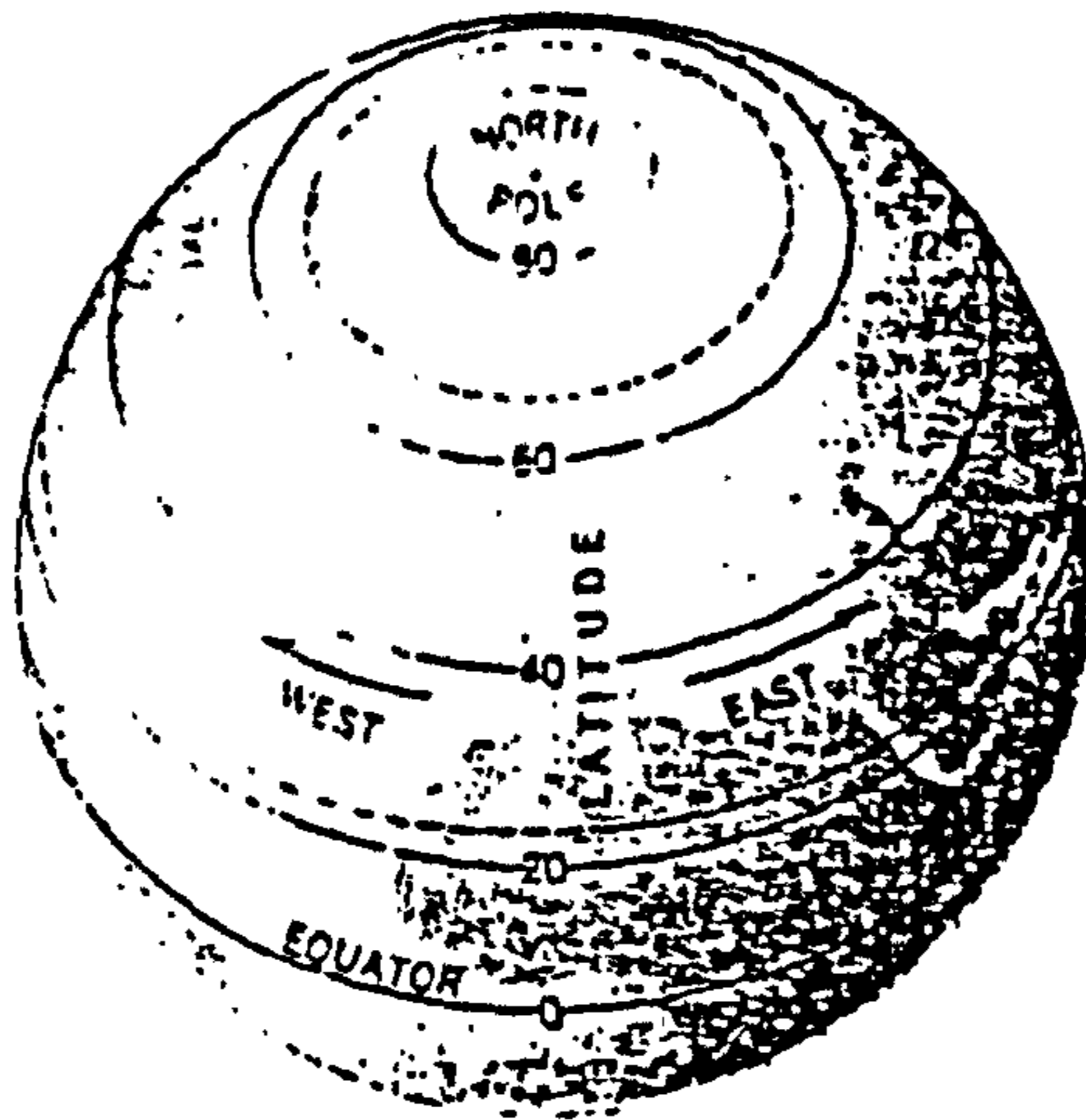

Figure 4.6 The Parallels of latitude (showing distance north-south) specify the directions east-west. (Source Trewartha et.al 1977)

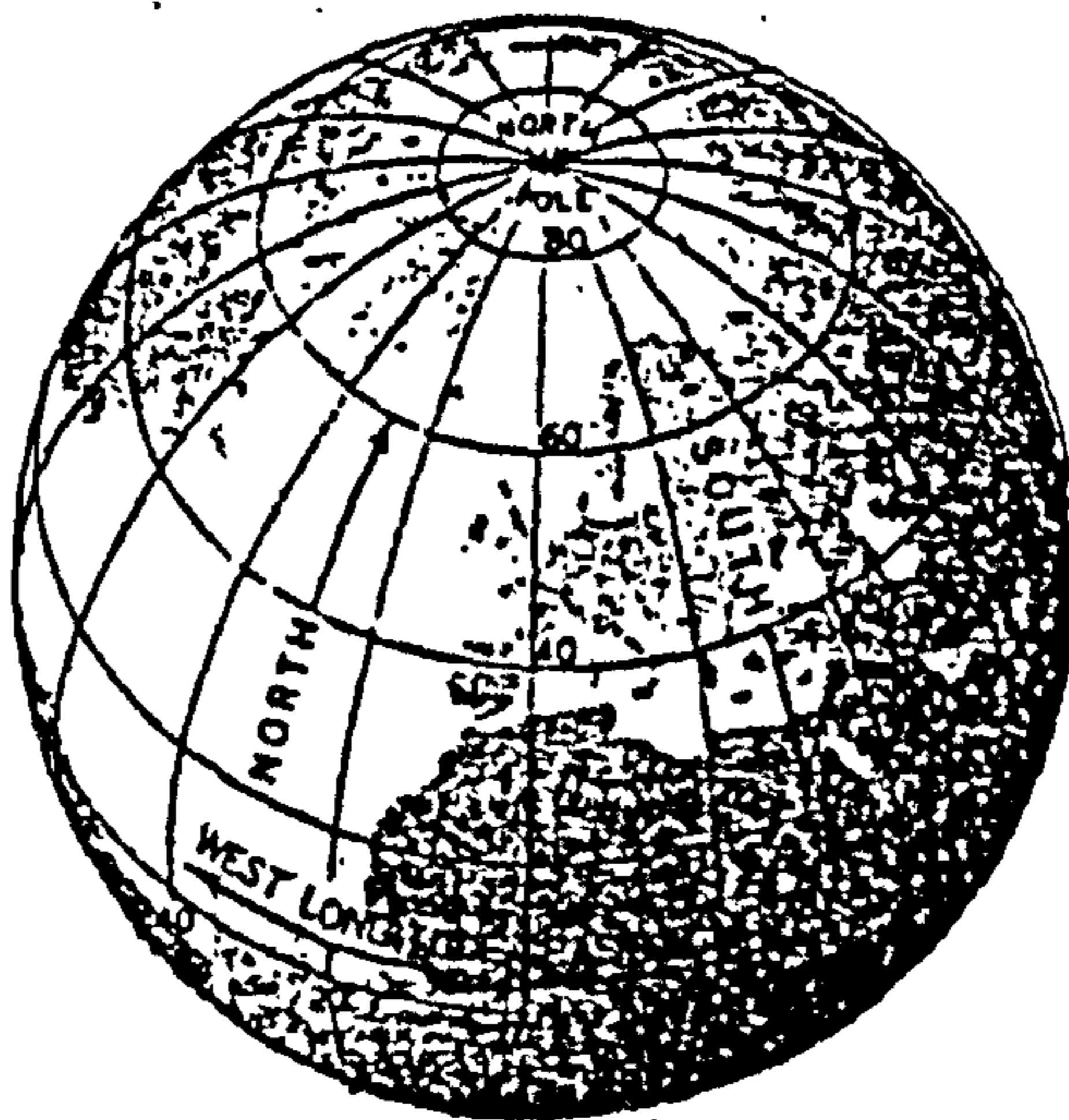

Figure 4.7 The meridians of longitude (showing distance east-west) specify the directions north-south (Source Trewartha et al 1977).

reckon distance east-west in degrees, minutes, and seconds of longitude. From a given meridian, selected as a starting line, east-west position is designated by the angular distance along the parallel circle in the latitude system as depicted in figure 4.7.

The equator is a great circle but, as they move toward the poles, the other parallels become smaller and smaller circles, while still divided into 360 degree. Therefore each east-west degree of longitude becomes shorter with increasing latitude and is finally reduced to nil at the poles. The relationship between the length of a parallel (the circumference of a small circle) and the circumference of a great circle (such as the equator or a meridian circle) is the circumference of the great circle multiplied by the cosine of the latitude of the parallel;

Length of degree of longitude = cosine of the latitude *
length of degree of latitude.

After many years of debate, the meridian of the Greenwich observatory is now accepted to be the prime meridian, 0.

4.4.3 Map Projections

Under no system employed to transform the spherical surface to a plane can the geometric relationship on the sphere be precisely duplicated on a plane. The angles, areas, distances and directions are inevitably subject to a variety of changes. Many other characteristics are also impossible to duplicate on a map projection. These includes parallel parallels, converging meridians, perpendicular intersections of parallels and meridians, and the representation of poles as points. The major alterations, however are those having to do with angles, areas, distance and direction. It is worth discussing these before the map projection is described to understand the affect on these by transformation.

4.4.3.1 Angles

It is possible to retain the property of angular relations to some extent in the map projection. When it is retained, the projection is termed conformal or orthomorphic, and both words imply correct form or shape. These terms apply to the direction of angles that obtain at points, but cannot apply to regions of any significant dimensions.

4.4.3.2 Representation of Areas:

It is possible to retain in a map projection the representation of area so that all regions on the projection will be represented in correct relative size. When this characteristic is retained, the projection is said to be equal-area or equivalent. This property is obtained by arranging the scale fraction in the principle directions so that the product of $ab = s = 1.0$ everywhere.

On such a projection $a = b$ can occur at only one or (at the most) two points or along one or two lines. At all other places $a \neq b$. Hence angles around all such points will be altered.

It is evident that the scale requirements for conformity and for equivalence in a map projection are contradictory, and therefore, no projection can be both conformal and equivalent. Thus all conformal projections will present similar earth regions with on equal sizes and all equal-area projections will deform most earth angles.

4.4.3.3 Distance

All map projections represent all distances "correctly" provided the scale variation involved is known. However, distance representation is a matter of maintaining consistency of scale. That is, for finite distances to be represented correctly, the scale must be uniform along the extent of the appropriate line joining the points being scaled.

4.4.3.4 Scale Factor

It is not possible to transform the spherical surface to a plane without differentially "stretching" or "shrinking" the spherical surface in the process. This means that stated scale (the ratio on which map is being represented) will fit only on a selected point or along a particular line; elsewhere the actual map scale will be either larger or smaller than the given ratio. This is true to some degree in all flat maps. The statement of the relation between the given relative factor and the actual scale value is called the scale factor (SF).

Scale Factor = actual scale / principle scale

4.4.5 The Classification of Projection

The usual categorization of a projection is based on general geometric characteristics. Conceptually, the spherical surface is transformed to a "developable surface", which is a geometric form capable of being flattened, such as a cone or a cylinder, or a plan, which is already flat. Conventionally, the axis of the globe is aligned with the axes of the cylinder and cone so that the graticule lines will be simplified as depicted in figure 4.8. In a projection based on a cone, meridians converge in one direction and diverge in an other; on the opened-up cylinder, meridians and parallels are straight, perpendicular lines. Projections on a plan are not so conventionally aligned and no generalisations can be made about their appearance. Such a constructional grouping of projections results in categories called cylindrical, conic, and azimuthal (plane), as depicted in figure 4.8.

In this section the Mercator, Lambert and orthographic projections are discussed in detail. Some projections are illustrated only graphically, such as Bonne projection in figure 4.9 and Hammer projection in figure 4.10.

4.4.5.1 Mercator's Projection

Mercator's projection (figure 4.11) is the most famous map projection ever devised. It was introduced in 1569 by the famous Flemish cartographer

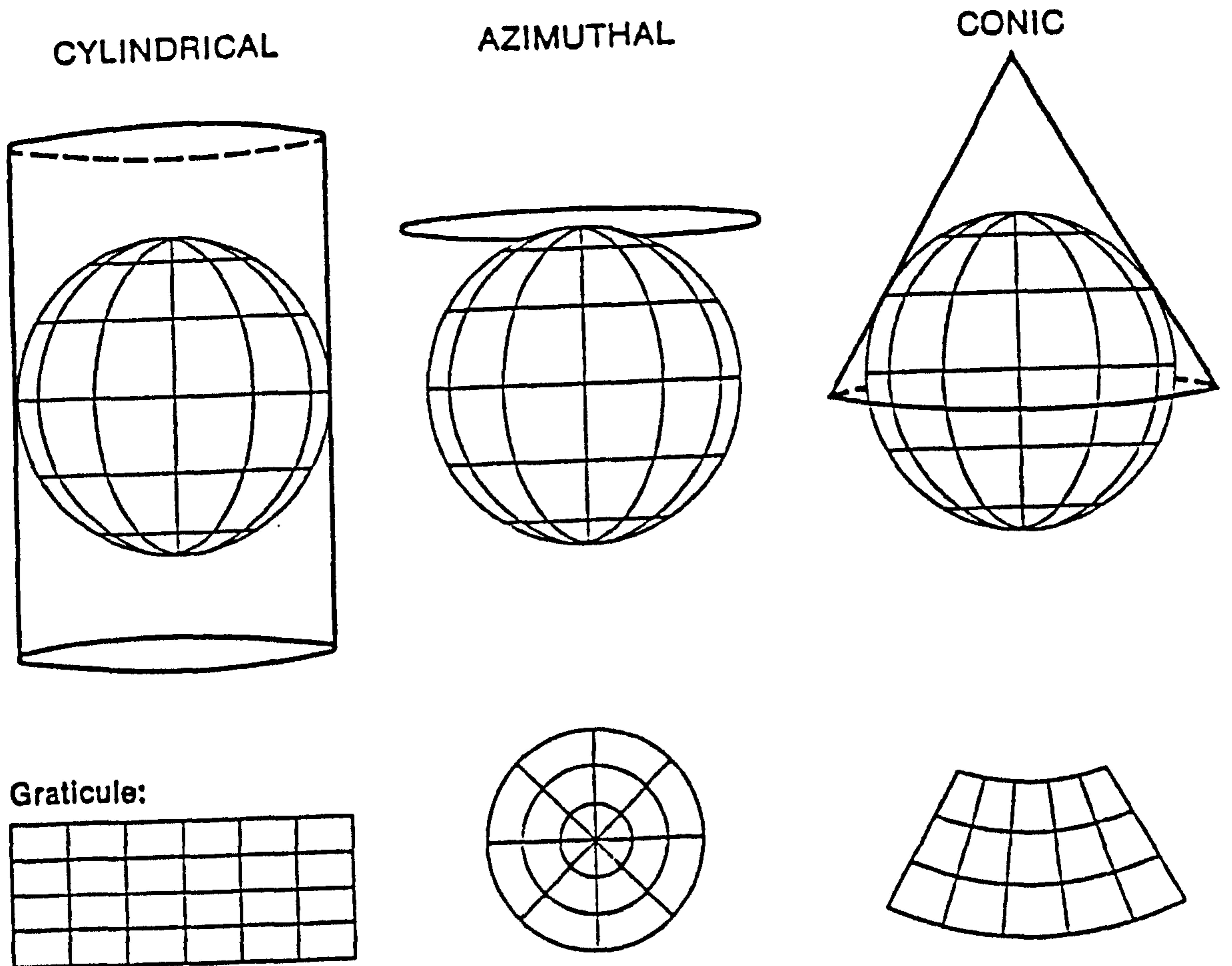
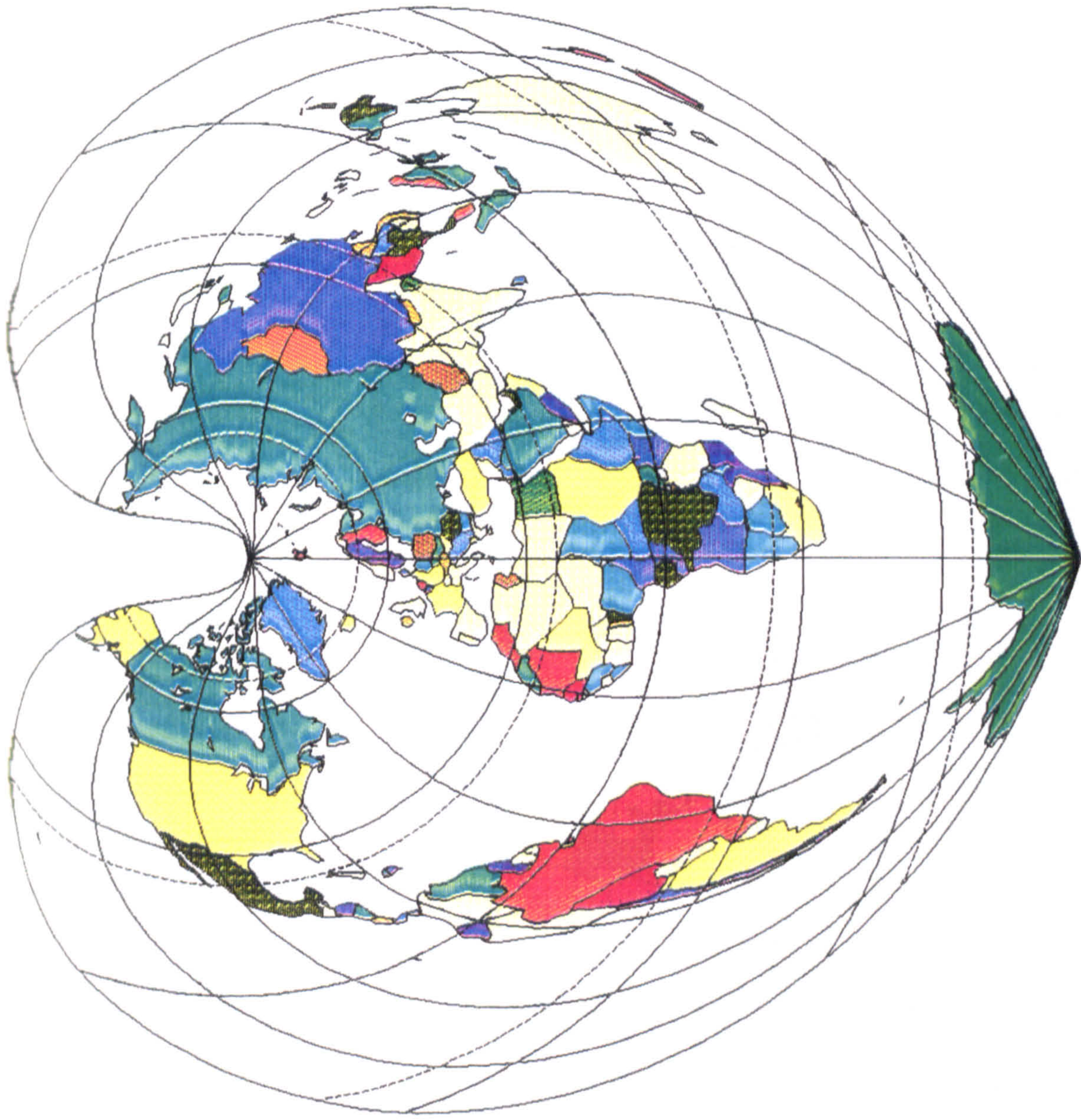
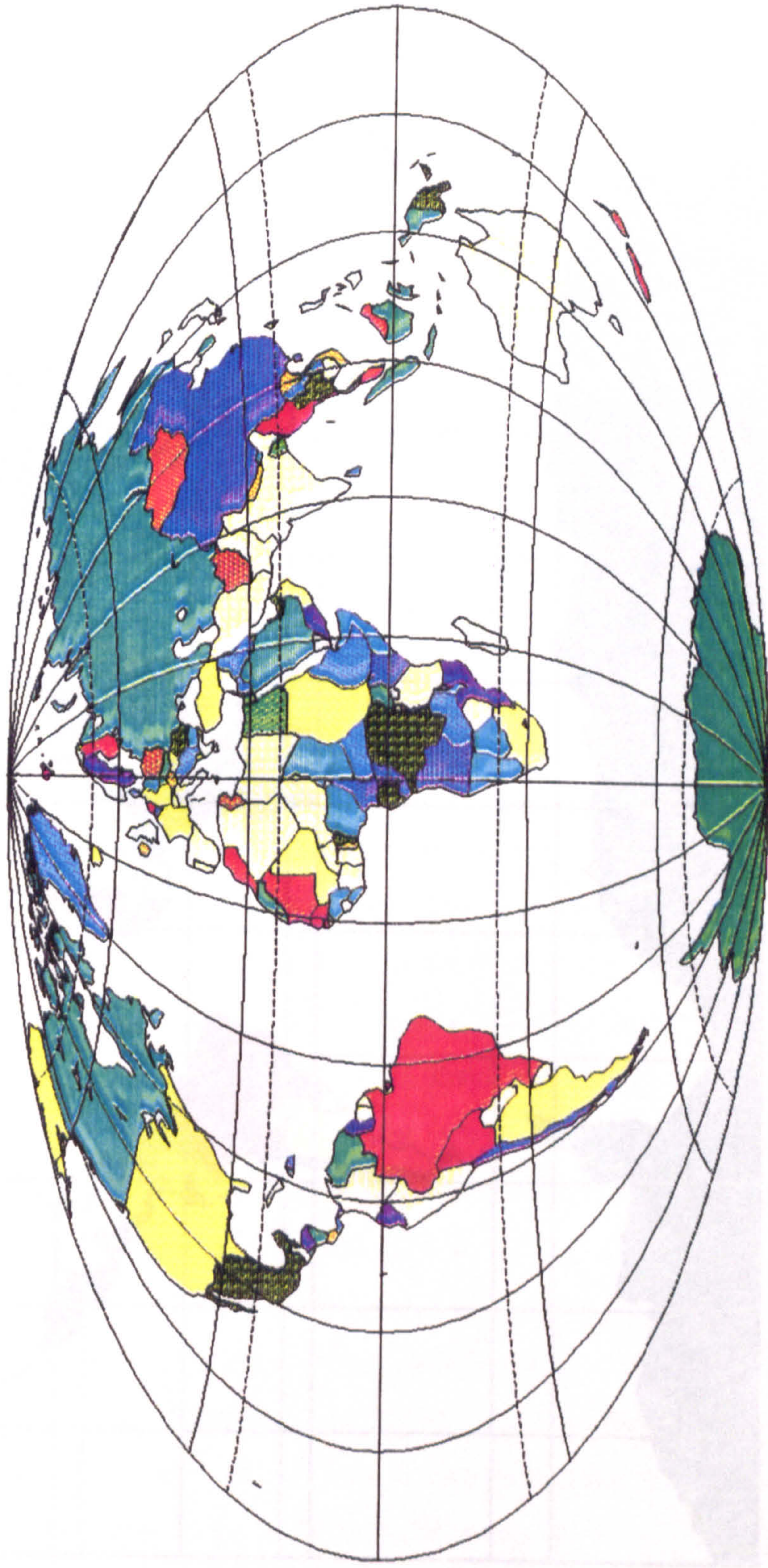

Figure 4.8 The developable surfaces to which the earth's surface may be "projected" and the appearance of the graticules when the transformations are arranged conventionally.



The Bonne Projection

Fig. 4.9



The Hammer Projection

Fig. 4.10

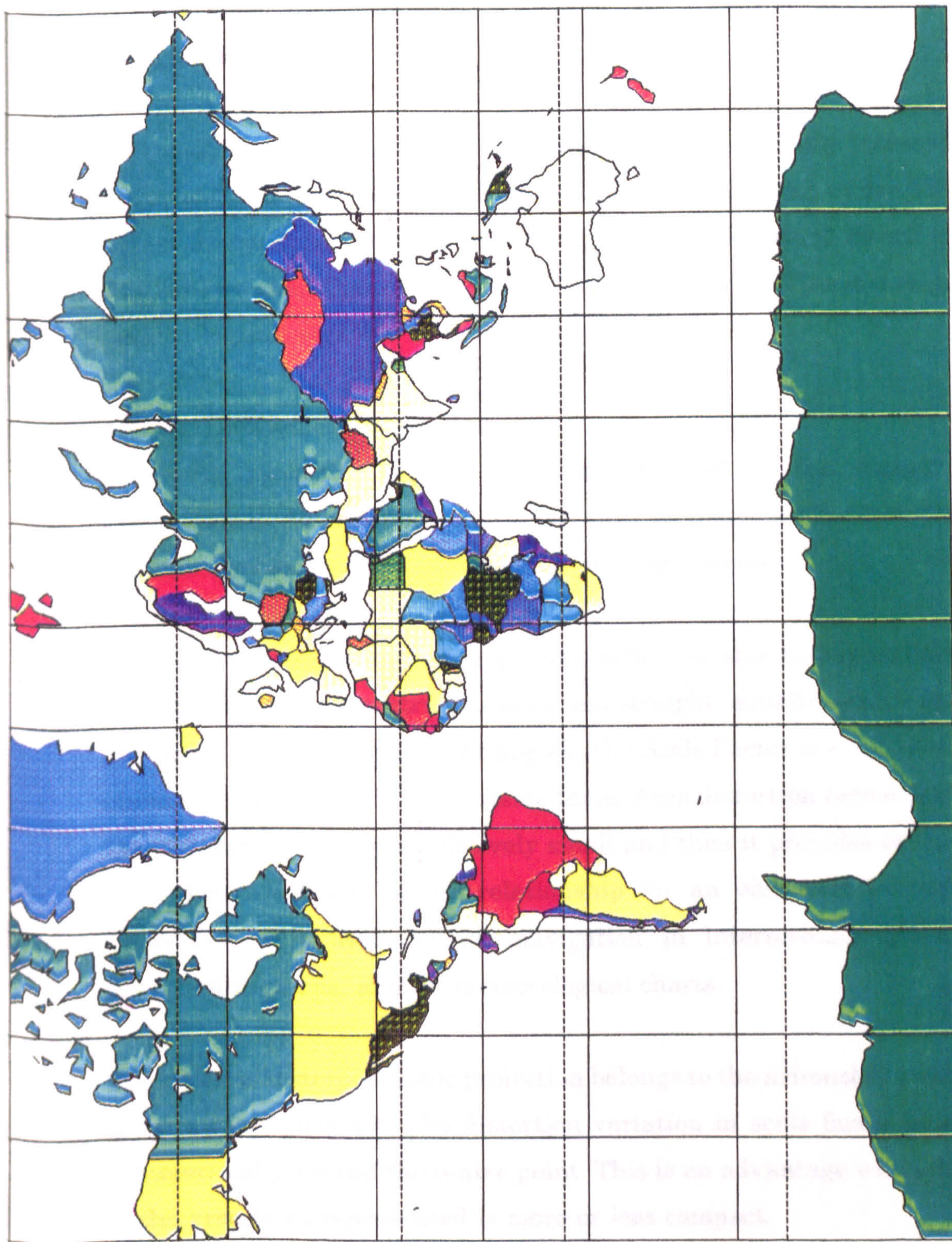

The Mercator Projection

Fig. 4.11

The Stereographic Projection

The stereographic projection depicted in figure 4.13 looks like a perspective

specifically as a device for nautical navigation. It is a cylindrical projection and all rhumb (rhumb is a bearing which intersects meridians at a constant oblique angle) appear as straight lines. It has obvious advantages for use in navigation.

Its major disadvantage is that it enlarges areas at a rapidly increasing rate towards the higher latitudes. Figure 4.11 shows the area under the Soviet Union as much larger than that of Africa and the area of Brazil as much smaller less than that of the United States of America. This is a major drawback in logistic strategy modelling.

4.4.5.2 Lambert's Projection

Lambert's projection (figure 4.12) was selected as the framework for international aeronautical charts because it combines conformality with relative ease in scaling distances and plotting courses.

Lambert's conformal conic projection with two standard parallels in its normal form has concentric parallels and straight, equally spaced meridians that meet the parallels at right angles. The Scale Factor is < 1.0 between the standard parallels and > 1.0 outside them. Area distortion between and near the standard parallels is relatively small and thus it provides exceptionally good directional and shape relationship for an east-west latitude zone. Therefore, it is used for air navigation in intermediate latitudes for topographies maps, and for meteorological charts.

The conformal stereographic projection belongs to the azimuthal group which is shown in figure 4.8. The distortion variation in scale factor is arranged symmetrically around the centre point. This is an advantage when the shape of the area to be represented is more or less compact.

4.4.5.3 Orthographic Projection

The orthographic projection depicted in figure 4.13 looks like a perspective

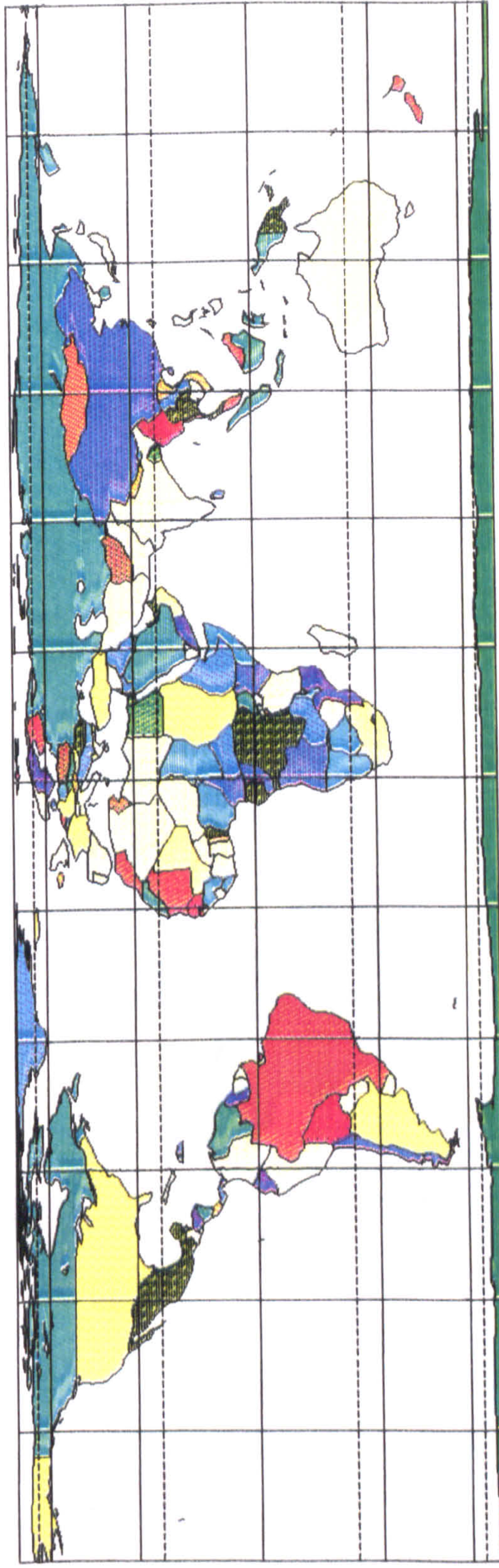

The Lambert Projection

Fig. 4.12

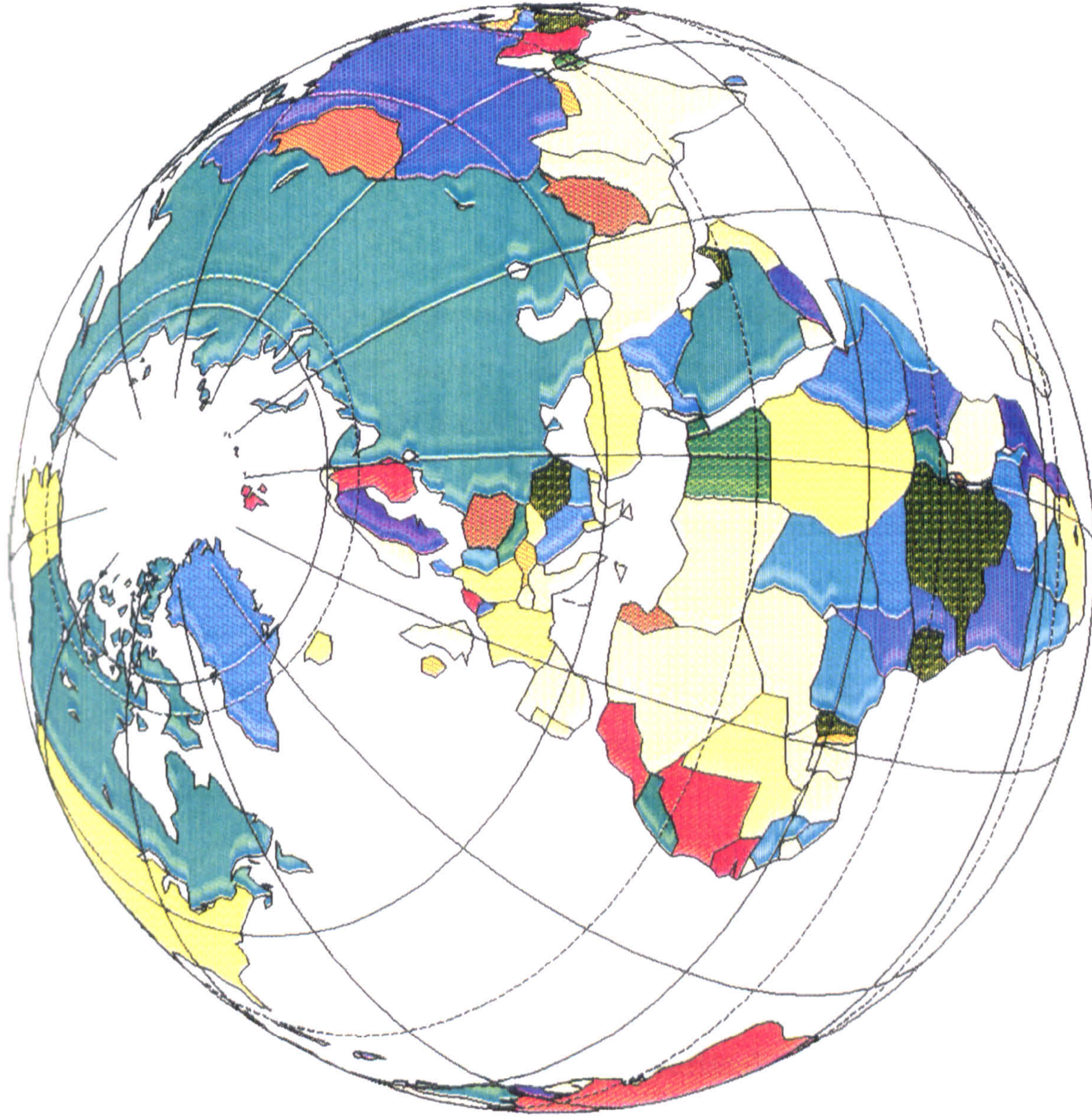

The Orthographic Projection

Fig. 4.13

view of a globe from a considerable distance, although it is not quite the same. For this reason it might almost be called visual projection in that the distortion of areas and angles is great around the edges but not apparent to the viewer. On this account it is useful for preparing illustrative maps wherein the sphericity of the globe is of major significance.

4.5 Problems of Projection for Computer Mapping

Map projections are important elements of the visually interactive modelling technique used for logistics system modelling. The map projection depends on the area to be considered and the projection to be employed. For example when a logistics system for the United Kingdom is being modelled, the map projections are not as critical as when modelling a logistics system for North America.

Mercator's projection severely strains the spherical surface, so that regions in the middle and higher latitudes appear both misshapen and grossly enlarged. Therefore it is not very useful for logistics strategy modelling. The orthographic projection is also not suitable to be used in LSM. Lambert's projection is employed in LSM to model the different logistics system.

4.6 Programming Language

The system is coded in Fortran 77 on an IBM PC computer, using the R.M.Fortran compiler. The programming language Fortran was chosen for number of reasons.

Firstly, Fortran is designed for scientific use, especially for handling numbers.

Fortran is also known as an imperative language, ie it provides the means of commanding the machine to perform particular tasks.

Fortran is a high level and powerful language that allows the user to develop a modular system, allows the programmer to test and debug the module

before linking it to the system. This saves a great deal of time which may have been required to run the system as a whole or test the entire program.

The language allows for the dynamic creation of variables, which is very useful when the memory requirement is not known in advance.

Fortran 77 is very strongly standard, which makes the source code portable to almost any computer PC, micro or mainframe.

It supports the direct access file which makes the use of database significantly faster.

The compiler allows for time checking of e.g indices to arrays. If a index is out of range, the execution will stop and the appropriate place in the source text will be pointed out.

The compiler supports overlays allowing the code to take up more than 64 Kbyte of memory, which is the normal upper limit on the code size on micro.

The compiler allows for calls to machine-code routine.

The compiler speed is very high which is very convenient for developing purposes.

The linker allows the building of libraries before linking them together, which gives the freedom to be able to link large number of subroutines.

4.6 Conclusion

In this chapter the constituents of the computer system, computer graphics and cartographic techniques has been discussed. The required hardware and its working has also been discussed in detail. These are important constituents of visually interactive modelling systems. The software and their

techniques are also vital to manipulate the hardware and model the logistics system. These will help the future logistics model developer to understand the basic computer hardware and software, and the cartographic techniques that are needed to develop visually interactive logistics models.

Chapter Five

State Of the Art in Practical Modelling

5.0 Background

In this chapter the logistics strategy models presently being used in the distribution industry will be reviewed. Most models are designed and used by private firms or consultants, so very little information is available in the literature. A number of companies were contacted for information on their software and requests were made to see software in operation. The postal response was about 60 % (which seemed encouraging), but mainly contained marketing publicity material. A number of "computers in distribution" exhibitions were visited, but there was no logistics strategy modelling software available for demonstration. The only way to obtain a demonstration was for the company "to visit your company"; demonstrations were not therefore forthcoming. Sorensen [Sorensen 1986] also had the same problem in his research into practical visual models for routing and scheduling. One answer received both by Sorensen [Sorensen 1986] and the author from the marketing brochures was that the model had all the capabilities and could solve all the logistics problems that might be identified.

5.1 Introduction

In the first section of this chapter, purpose built models for logistics systems modelling will be described. The second section is devoted to computer spreadsheet modelling, which is a growing technique for model development.

Ballou [Ballou 1984] has indicated that the comparison of purpose built models may not be useful. He gives the following reasons:-

- i) Usually such models are proprietary and cannot be used for comparative purposes.
- ii) The different assumptions round which these models are developed make

comparisons inappropriate.

iii) Using the basic logic of the various model types on a small manageable size of problem does not allow an adequate comparison of the efficiency and accuracy of a model intended to deal with the strategic network planning problem of a large corporation.

It is however important for management scientists to look at the history of modelling, examine what is available at present, visualise what will be needed in future and then develop it. The following points will be discussed in the consideration of different models:-

- the objective for the development of the model;
- whether the model was developed for a personal or a mainframe computer;
- whether model uses high resolution computer graphics;
- whether the model was developed for strategic or operational planning;
- levels of echelon of network (chapter two);
- the algorithmic techniques eg simulation, optimisation or heuristic (chapter six);
- capacity limits, eg on depots, factories, etc ;
- how close the model approaches reality, ie. the amount of data it can handle such as the number of different products, the number of customers or market areas, the number of factories and depots, etc.;
- ability to handle different transport modes, vehicle types etc;
- the distance calculation;
- the allocation of market areas to distribution depots and distribution depots to factories and method used ;
- the different costs that are considered for modelling purposes;
- output report facilities;

As in chapter three the review will start with simple models and will proceed

to more comprehensive models at a later stage. The models will be described in the following order:- Poligami, Capflo, Transpart, Displan, DiPS, Locate, Deploy, Site, and Distribution Strategy Simulator/Stradis.

5.1.1 POLIGAMI

Poligami [Poligami 1970] is a software package which was developed in 1970 for mainframe computers by using Fortran IV.

Poligami is capable of modelling a two-stage distribution system for a single product. It is able to model for more than one product if only one stage of distribution is required. Poligami is able to handle plant production capacity and upper limits on warehouse size, fixed charges and simple economies of scale for warehouses. It serves each customer from a single warehouse. It allocates the customers to the closest warehouse. It is able to handle the transfer of products between warehouses. In terms of operational research techniques Poligami, is an optimisation model.

From the above features the following conclusions are drawn about Poligami;

It does not utilise the user-friendly power of computer graphics technology. Its allocation will result in a sub-optimal allocation of customers. It does not include the inventory cost for a logistics system. In a two-stage distribution system only a single product can be modelled at any time. It was developed for mainframe computers and therefore it cannot be run on personal computers.

Poligami cannot therefore be used to model the present complex logistics system.

5.1.2 CAPFLO

Capflo was developed in the early seventies by Figgens and others [Figgens et al, 1973]. It was basically designed to solve problems concerning a single product and a two-stage distribution system. Capflo is able to handle the

plant capacities and upper limits on the warehouses size, and fixed charges and economies of scale for warehouses. It can also model for more than one product if there is only one stage of distribution, and several types of systems configurations constraints. It does not handle in general and in exact fashion lower limits on warehouse size. It also required that each customer should be served from a single warehouse. The customers are allocated to the nearest warehouse. In term of operational research techniques it classified as an optimisation model and is written in Fortran IV.

The model is unable to operate on PCs, and does not utilise the user-friendly power of computer graphics. Capflo will produce sub-optimality on allocations of customers. The number of products it models is limited to one in a multistage distribution system. Capflo closely resemble the Poligami system [Poligami 1970] and therefore the same conclusion is drawn about its capability for modelling the present complex logistics system.

5.1.3 TRANSPART

Transpart is a decision tool which was developed by Blumenfeld and others [Blumenfeld et al, 1987] for General Motors (GM). It was written in Fortran 77. The main objective in the development of Transpart was to allow GM to conveniently examine the impact on total corporate cost of different shipping strategies for its products. The first version of Transpart was develop for mainframe computers but the second version runs on a personal computer and utilises the high resolution power of computer graphics. The model was developed for operational rather than strategic planning.

Transpart analyses the transportation and inventory cost trade off and determines the minimum cost for the entire network. It can handle up to forty different products. The freight rate it considers is a fixed amount per load, independent of the size of the weight per load. The model incorporates the inventory holding costs. It gives output reports for route, shipment size and a breakdown of costs by link. It only considers the product movement

from warehouse to customers or from factory to customers.

TRANSPART uses a network decomposition solution technique to evaluate the costs of alternative shipping strategies. Since the development objective was to consider the trade off between inventory and transportation costs it mainly deals with this point.

The following conclusion is drawn about Transpart:

It is a purpose-built operational model and too specific to GM requirements. It is not able to model a logistic system which moves goods from factories to depots to customers and from factories to depots to transshipment points to customers. Therefore, it is not able to model the logistics system at strategic level. However it does use the user-friendly power of computer graphics and operates on micro-computers.

5.1.4 Distribution Planner (DISPLAN)

Displan [Ballou 1984] is a model for the strategic planning of distribution networks. The main objective in its development was to handle a non-linear inventory cost. It is a multiproduct distribution model and includes the following costs:

- i) production/purchase costs;
- ii) Warehouse storage and handling costs;
- iii) Inventory costs;
- iv) Stock order and customer order processing costs;
- v) Warehouse inbound and outbound transportation costs;
- vi) Customer service related cost treated as a constraints;

It uses the 3-dimensional transportation algorithm of linear programming. The algorithm is used in an iterative fashion to converge on the minimum

cost network configuration, subject to facility capacity and customer service constraints.

Displan solves the distribution problem by starting with a high cost but feasible solution. It converges on approximately optimum solutions by means of the iterative use of the 3-dimensional transportation algorithm of linear programming. The approach is to force a computational start with the maximum number of warehouses or stocking points. The typical solution gives higher possible inventory levels and consequently higher level of inventory and fixed costs.

Ballou reported that Displan has been used for a number of case studies with the following number of products, plants, warehouses and demand centres:

Products	Plants	Warehouses	Customers
13	9	58	192
2	7	22	323
14	23	28	121
7	7	90	121
20	23	61	191

Table 5.1

Ballou also tested the computer running time and found that it was a factor of the number of product groups, the number of plants, the number of warehouses, and the number of demand centres. As might be expected, the larger the problem is the longer it takes to solve.

However Displan has the following disadvantages to be used for visual interactive modelling:

Displan is not able to run on micro-computers because it was designed to operate on mainframe computers. It does not utilise the user-friendly power of computer graphics. These two aspects are very important for any model to be used widely at present in the distribution industry.

5.1.5 Logistics Planning System (LPS)

Carlisle and others [Carlisle et al 1987] developed a logistics planning decision support system for Marshalls Inc. The program was written in Fortran 77 and runs on micro-computers. The LPS network design is based on Barr et al [Barr et al, 1981] and network optimisation is achieved by using Simplex algorithm of Kennington [Kennington 1980].

LPS is an optimisation model and contains three optimisation modules; Optimisation of vendors sourcing and of flows to facilities, flows from facilities to retail stores and facility location.

LPS is a multi-commodity model and has been reported to have been used with five products, five processing centres, twenty warehouses and 350 customers. It has been used to develop a five-year strategic plan.

There are no upper or lower limits of warehouse throughput or plant production.

The major draw backs for LPS are that:

- it does not include the inventory cost for logistics system modelling. The inventory cost is a very important cost in a logistics system design.
- it does not utilise the user-friendly power of computer graphics.
- it is a purpose built model for Marshalls Inc and therefore too rigid to be

considered for other logistics system.

- it assumes that all the warehouse and production plants are located on green field sites. This assumption is correct in some cases but does not hold for all logistic systems.

5.1.6 Distribution Planning System (DiPS)

According to DiPS [DiPS 1988] introductory brochures, DiPS is a simulation package that utilizes the simulation technique to model the distribution system. The prime consideration in the design was the complete integration of each distribution module into the system.

DiPS was developed for mainframe computers and for use for both operational and strategic logistics system modelling. The brochures claim that there are no upper limits on the numbers of customers, depots, plants and different products that can be modelled.

For distance calculation it uses the real distance for local and trunking deliveries. It also incorporates any hazards or barriers in the modelling area. The DiPS includes three data banks:

- i) a postcode databank, containing all the postcodes in United Kingdom;
- ii) A gazetteer, containing over 32,000 places names in UK and their associated grid references.
- iii) A road network data bank, to calculate the real distance.

According to brochures, DiPS is able to do the following for any distribution system:

- (a) Set up and maintain the distribution data.
- (b) Set up and maintain the clusters of distribution points either by postcode, software or user control.
- (c) Use the road database to establish the driving standards to be used

throughout the study.

- (d) Undertake "overview" distribution planning exercises covering many levels of depot operations and product flows using the warehouse location and costing model.
- (e) Produce "fine detail" distribution plans at route schedule level to examine fleet composition, define fixed routes, etc.
- (d) Manipulate routes using a manual route-building facility.
- (e) Enter orders for any distribution point in the central database.
- (f) Schedule on a day-by-day basis according to job priority and the load planners' criteria.
- (i) Schedule trunking fleets through a complex depot network and evaluate own fleet versus third party costs.

The brochures claim that the actual depot locations chosen will depend on a number of computer runs using fixed and floating depot locations. The brochures also claim that allocations are very complex but that on the information provided by the company, the actual algorithm can be tailored for each company's requirements. (This is a classical example of a model doing everything).

DiPS has three different route planning facilities: a) strategic route planning; b) the manual route building; and c) daily route planning. Only the strategic route planning facility will be described here.

The brochures states that the overall objective of strategic route planning is to minimise the travelling time and maximise vehicle utilization. The results obtained contain the following details:

- Travel and work times;
- Name, address and grid references;
- Earliest arrival times;
- Latest departure times;

- Quantities delivered and collected;
- Resources available and used summaries;
- Utilisation reports.

This seems to be a operational route planning rather than strategic route planning. For example, in strategic level modelling for 1992, it is impossible to calculate or predict the time a customer is going to want deliveries or collections.

The major drawbacks of DiPS are that:

- it is operational logistics modelling software. This is a classic example where a software is developed to model both strategic and operational systems. It needs great detail of data and information for modelling purposes, which are difficult to predict and obtain for modelling at strategic level.
- it does not include the inventory cost in its logistics system costs.
- it uses simulation techniques in which only limited options can be tested.
- It uses real distances, which may not be available when designing a new distribution system in developing countries.

However, the new version of DiPS runs on the IBM Personal computer or any compatible machine, and a new user-friendly computer graphics interface is under development. The micro-computer version is not able to model unlimited numbers of customers, depots and factories.

The availability of micro-computers and the demand for models utilizing the user-friendly power of computer graphics is such that they are forcing the developed models already in the market to change their basic objectives to include these new developments.

5.1.7 LOCATE II

Locate II is an interactive computer model, but not graphically interactive . The main objective in the model development was to assist managers

attempting to analyze multiple facility distribution systems. Locate II uses a heuristic algorithm to construct and evaluate proposed distribution centre locations. The model is built on the assumption that many managers wish to explore a relatively limited set of alternative locations rather than to consider all possible locations for optimisation.

Allocation

Locate II links each market to the warehouse which can serve it at lowest outbound transportation cost. It also allows the manager to overwrite its allocation.

Plant-Warehouse Assignment:

Locate II assumes the existence of one or more plants producing a single product. All of this product is assumed to move in full truck loads from plants to distribution centres. It allocates the warehouses to the nearest plant.

System Costing :

Locate II includes the following costs:

- a) Local delivery cost, the cost of movement of goods from warehouse to customers, calculated by multiplying the total demand by rate per weight.
- b) Trunking cost, the transportation cost from factory to warehouse.
- c) Warehouse cost, including a fixed cost which is independent of throughput and a variable cost which depends on throughput. The total warehouse cost includes the fixed cost plus the total throughput multiplied by the handling cost per unit.

Report Generated

Locate II generates three primary reports during its operation, a cost summary, a service summary, and a routing summary.

Cost Summary:

Locate II prints a summary system cost on each run. The cost report displays warehouse to market transportation costs by weight class, plant to warehouse transportation costs, and warehouse operating costs. These costs are also totalled and reported as the total system cost.

Service Summary:

A service report is available at the user's request during a run of Locate II. The service report displays the percent of customers and percent of markets served within program-defined mileage blocks. This report is issued for each of the weight groups in which demand has been classified.

Market to Warehouse Assignment Summary:

When Locate II solves the warehouse-market assignment problem it makes available to the user a detailed report called a market to warehouse assignment summary. This report indicates which warehouse should serve which market for each weight group. The market to warehouse summary also prints the rate at which the product will move from the warehouse to the market and the distance between them. The routing summary is available at the user's request during the execution of the program.

Locate II does not deal with inventories at any distribution depot. It also does not attempt to measure the impact of inventory turnover on the warehousing costs.

A new version of LOCATE II known as Euro-locate is now available. The following objectives for Euro-locate were defined:

- (a) to help distribution managers to meet their primary logistic mission: how to reduce the distribution cost while improving services to the customers.
- b) to use mathematical modelling techniques, easy to read reports,

mapping graphics and business graphics, to help to identify ways to cut costs, reducing the asset base, release stocks and improve product flow.

- c) to use mapping graphics to display the key elements in the logistics data base such as shipping territories, demand concentration and net landed cost on an international map.
- d) to use business graphics to help to identify and communicate the best distribution network from list of alternatives.

Euro-locate seems very good indeed but no independent research report is available to test the defined objectives. How closely Euro-locate fulfils the stated objectives is not known.

5.1.8 DEPLOY

DEPLOY was developed for logistic strategic planning. It uses heuristic methods and does not guarantee a global optimum solution. It calculates the distance for trunking and local deliveries from grid coordinates by using Pythagoras' Theorem and adds extra distance for barriers and congested areas. It can handle both factory to depot to customers structures and factory-depot to customers structures. The program allocates customers to the distribution depots from which they can most cheaply be supplied, and distribution depots to plants on the same basis.

DEPLOY calculates the cost of local delivery, trunking, inventory, and the fixed and running costs of distribution depots.

DEPLOY uses an "infinite set" approach [Eilon et al 1971], beginning with the maximum number of depots and then removing one depot at a time by using Feldman's dropping procedure [Feldman et al, 1966]. This process continues until no further cost improvement can be made. When cost zone structures are used, it also performs a search procedure which examines for each depot in turn to determine whether it could be profitably located in a

neighbouring zone.

Output Report

In its output report, DEPLOY gives the following details:

Depot names, locations, throughput, and total cost. It gives details of customers and depot allocations. It also gives details of local delivery costs, trunking costs, warehousing costs and total costs.

The model was coded in Fortran IV for mainframe computers but also runs on micro-computer. It is able to model more than one product at a time.

The major drawbacks of DEPLOY are that it does not use the user-friendly power of computer graphics. It assumes that warehouses and production plants are located in a green field areas. It is not able to include the transshipment point when modelling the distribution system.

5.1.9 SITE

The version of Site being reviewed was developed by Synergy in 1987. It deals with zero, one or two echelon, depot to customers, factory to depot to customers, and factory to depot to transshipment point to customers distribution networks. It is a capacity constraint model and has upper limits on factory and depots. It calculates distances by using grid references and Pythagoras' theorem. It also deals with minimum distances between the depots and maximum distance for customers.

SITE can handle up to 2100 calls. It can also deal with more than one frequency of delivery per customer per modelling period. Site's demand and cost functions can be increased or decreased by percentages.

Output Reports

SITE's output is in the form of printed reports and, as an option, computer-

produced maps (on the printer not on the screen; Site is not a graphic interactive package). It lists up to fifteen alternative solutions together with their comparative costs, and for the solution chosen specifies in detail all the customer-depot links, lists the trunking requirements, and gives a complete breakdown of costs.

The main disadvantages for SITE are that it only models one product in a logistics system. It is able to run on personal computers but does not use user-friendly computer graphics. In its total cost it does not include the inventory carrying cost at a warehouses. Therefore it is not able to model the present complex logistics system.

5.1.10 Distribution Strategy Simulators:(DSS)

and

STRADIS

DSS and STRADIS have similar roots, capabilities, modelling objectives and theories. Therefore, they will be considered together in this section. DSS is a simulation base package which was developed in early eighties to be used both for operational and strategic planning. The objective in the development of DSS was described by Waller [Waller, 1983]:

"DSS was designed as a modelling system comprising a suite of computer programs capable of being moulded into a particular representation specific to a particular application by the data put into the system and by its subsequent use"

DSS models up to 40 different product groups, maximum six delivery costs, 10 drop size categories and 1,000 customers. It can handle up to 100 facility locations including the factory depot and transshipment points. The maximum number of transport modes it can consider is 10.

Allocation

It allocates the demands points to supply facilities throughout so as to build up a complete path from source to final delivery on the basis of least total cost subject to any imposed restrictions on flow through the network. In order to do this it makes use of estimates of units costs of production, handling and trunking at each point of the network. The user has the option of override the computer's allocation decision. It can use either the real distance or grid coordinate distance.

Costs:

DSS considers local delivery, trunking, inventory, and depot fixed and operating costs for logistics modelling.

Transport and Transport Costs:

As described, DSS is capable of dealing with more than one mode of transport and has three different procedures for cost calculations, using costing tables, the "van route cost model" and by linking in special custom-built sub-routines for transport cost.

The Transport Cost Tables:

This is the method normally used for trunking. The user provides a table of costs for a range of throughput and distances or driving times. The DSS program interpolate as necessary for intermediate values and can handle the variations in the transport costs which arise.

The Van Route Cost Model:

This application is used for more precise modelling.

The values required are:

- Van capacity
- hours in the working day
- fixed time per delivery
- variable time per unit per delivery

- interdrop speed
- fixed cost per van day
- additional cost per van miles.

For cluster or zone applications, there must be also be a radius and a service frequency.

Customer-built Transport Cost sub-routine:

This sub-routine is provided for the use of planners who need to represent precisely a complex tariff systems.

Output Reports:

The DSS gives comprehensive detail reports for all facilities, products, modes of transportation and customers.

DSS has been prepared initially in two versions, for the IBM 370 and PDP-11 computers. The system is programmed in FORTRAN IV and operated entirely from a keyboard terminal and visual display unit (VDU).

The major drawbacks of DSS are that it is another example of a model designed to model both at strategic and operational levels. The simulation is used as a technique to model great details of data and to handle such an amount of data a mainframe computer is needed. These models are becoming out of date. Therefore a user-friendly computer graphics interface and a personal computer version of DSS are now being developed.

5.2 Spreadsheet Models

A spreadsheet is a declarative language that automatically attempts to solve any simultaneous equations that it may be presented with. Lotus 1-2-3 has been very popular with managers of financial and marketing application [Winter, 1989]. The power of Spreadsheet was enhanced by the existence of

other commercially available software such as VINO (Visual Interactive Optimisation) [Cunningham et al 1985] which can read a spreadsheet, find a optimum solution and write into spreadsheet. Spreadsheets are being used for decision analysis, expert systems, optimisation, risk analysis simulation, and statistical analysis and forecasting [Bodily, 1988]. Jones showed how a spreadsheet can be used to build, solve and perform sensitivity analysis on a decision tree [Jones, 1986]. The advantage of having a tree in a spreadsheet is that "what if" and sensitivity analysis are very much easier. Sensitivity analysis results can be stored and portrayed graphically. Spreadsheets that include the decision trees help presents the analysis to others. The drawback is that "drawing" in spreadsheet is cumbersome; only small trees can be treated this way. There is some special software such as Arborist or Supptree. Arborist has graphic aids for building and presenting trees and Supptree offers more options for analysis and links to many spreadsheet and financial planning packages [Bodily 1986] and is competitive in price.

Winter used the Lotus 1-2-3 to design a marketing mix for a new product of a sporting goods manufacturer that would yield the greatest profit. A Lotus 1-2-3 work sheet offers a convenient and "manager friendly" way to select appropriate marketing mixes to target to various market segments [Winter 1989].

Jennergren demonstrated that it is possible to write the expressions that optimise a linear model (using the simplex algorithm) in the spreadsheet language itself [Jennergren 1984]. However he restricted the problem to seven variables and three constraints, enough to be of interest for teaching optimisation and spreadsheet but too small for nearly all problems faced in industry. Software such as VINO and LP83/MIP83 can handle many more constraints and variables.

There appears to be no commercially-based software available which was developed entirely in spreadsheet for logistics strategy modelling that can be

explored here. Only one system which was developed at Distribution Studies Unit by Clark is known to us and will be highlighted here [Clarke 1988].

Clarke developed a spreadsheet model for strategic planning in Lotus 1-2-3. The model was developed for MSc students in order that they should become familiar with strategic planning for distribution and be able to use Lotus 1-2-3 to solve problems involved in strategic planning. The model is entirely confined in Lotus 1-2-3 and uses the Lotus macro facilities and its commands for operating purposes.

The model has only one warehouse and deals with only a single product but can handle several factories and delivery points. It calculates distance by using the grid coordinates and takes wiggle factors into account. The model assumes that the minimum delivery or collection is one load. To place a depot in best possible location, the model uses the search algorithm. The model has a static treatment of time and assumes that all variables except the ones it is dealing with will remain constant. Each run of the model is completely separate from previous runs, and it does not build on previous results.

The model outputs the map of UK, and locates on it the delivery, collection and storage points. It also displays on the screen delivery, collection and total costs.

Spreadsheet flexibility is without doubt its major attribute. The ease with which variables can be changed and "what if" analyses taken is a major advantage. The spreadsheet nature makes them perfect to do trade-off analysis. However this type of analysis is only possible simultaneously between only two or three variables and assumes all the other issues to be fixed. Flexibility and manageability are very good while the spreadsheet are small, but deteriorate as the size of the spreadsheet increases. The spreadsheet models are easy and user-friendly only for those that have developed them; they are not easy to transfer. The task of analyzing model

structure formations and flow charts are very difficult with spreadsheets.

Spreadsheets' main advantage is also its major weakness - spreadsheets are too flexible. The validation of data is difficult and input of an error very easy, thus making accurate spreadsheet operation a difficult task. The robustness of the models is low and the use of them by other people is a problem. Generally, the very nature of the spreadsheets themselves and the lack of formal training in modelling can cause the following problems.

The spreadsheet models tend to be developed as prototypes without the necessary features required for generic application. The accuracy of the model as a fair representation of reality may not be achieved. The amount of time required to develop spreadsheet models has been vastly underestimated. This could hide the true costs involved. Spreadsheets have excellent representational graphics such as bar charts, line plots, pie charts, or other forms of data representation. However at present spreadsheets do not have facilities for iconic graphics modelling (chapter three). To use Bodily's terms, graphics are exploited now for output of models; their use for building models has lagged [Bodily, 1986].

Spreadsheets have a limited number of columns for storing data and most importantly they are not designed for logistic modelling purposes. To do that, the operations research scientist must write a program called macro in it. Spreadsheets are not able to handle more complex algorithms such as depot location and boundaries and fleet size and mix in a multi-drop environment.

5.3 Conclusion

All the reviewed models are market driven. The models developed by firms of consultants were based on the assumption that they will be able to model any logistics system for strategic and operational planning. This made these models to be too general and too many detailed for operational logistics planning purposes. They also need mainframe computers to run on and

simulation technique to model details. Waller states that simulation was chosen because this was the only way of maintaining complete freedom regarding the shape of distribution systems and the nature of the cost and resource relationships [Waller, 1983].

The major problems with these models are their data requirements and their need for mainframe computers. They require greatly detailed information which is usually not available for strategic planning, and therefore they deter managers from using them for strategic planning. These model need mainframe computers which are not as widely available as micro-computers.

The other drawback of these models is that they were intended for specific users, ie consultants, who knew the model well and were probably involved in its development; end-users were not considered at the designing stage. This makes the model very difficult to use and some of the models are not being used because the individual who knew its operation is no longer with the company. This problem was also highlighted in chapter one.

The other types of models are purpose-built for a particular task, which makes them too rigid to be used for any other problems.

Spreadsheet models are new and no commercially-based package is available to be fully examined. They may need further development in terms of macro facilities and graphics capabilities before they may be considered useful tools for logistics strategy modelling by management scientists. At present they are very useful tools for business graphics.

The early seventies was a period of optimisation to reduce costs. The problem with optimisation at that stage was the difficulty in including all the logistic details and deriving a solution in a reasonable time and cost. The eighties was a period of simulation because of the need to include every cost detail for modelling. The nineties will be years of heuristics.

However, it is clear that power of personal computers in terms of cost, availability and user-friendly graphics is so great that all the mainframe packages are converting toward it even on sacrifice of some great details and their original and fundamental objectives.

The review of these models clearly demonstrates that there is no visually interactive model available which is versatile in terms of modelling algorithms, uses the user-friendly power of computer graphics, is able to model distribution systems at the strategic level, and can handle reasonable numbers of customers, depots, factories and products on a micro-computer.

Chapter Six

Approach to model development, how and why

6.0 Introduction

In this chapter, mathematical techniques which are available to the practitioner for modelling logistics systems will be discussed. There is no single method which can be used for designing the logistics system for every case. Because of the complexities of logistics system, there are several methods available and each is appropriate for a different aspect of logistics planning. It is up to the planners to decide which technique is best suited to achieve their defined objective.

Optimisation, simulation and heuristic techniques are described in the following pages. There will also be comparison among these techniques to show which techniques offer best possible solution for a particular problem. The advantages and disadvantages of personal computers and mainframes are also compared and discussed. The use of computer graphics in modelling and a survey of visual interactive modelling techniques will be given, and the ideal models for the nineties will be portrayed.

6.1.1 Optimisation

In its simplest form, optimisation merely means that there is no better answer to a given mathematical problem [Powers 1989]. Ballou [Ballou 1989] defines optimisation as an ideal way to solve a problem, where the problem is represented in the means of mathematical expressions, and the best alternative is found through the application of mathematical logic. This mathematical logic is embodied in such well-known procedures as differential calculus and mathematical programming.

There are different degrees of optimisation in a logistics system, global optimisation and local or partial optimisation. Both have a different function

and part to play in a logistics system. Global optimisation is achieved when total logistics system has been optimised. Partial optimisation is attained when some but not all the constituents of a logistics system are optimised.

One type of optimisation is complete enumeration. If a person or a computer is able to look at every conceivable combination of variables in a given problem, the best one can be found and confirmed by inspection or mathematical comparison. As planning and decisions become more complex, such straight forward enumeration becomes intractable even with powerful computers. The most advanced mathematical programming techniques such as linear programming, network optimisation, integer programming, mixed integer linear programming and non-linear programming are needed. All these techniques have one crucial trait in common: the solution they produce can be proved mathematically to be the best achievable under the circumstances. The methods to solve the above techniques are branch and bound, primal decomposition and steepest ascent.

The advantages of using optimisation in logistics system can be summarised as follows:

The most obvious is that the user is guaranteed to have the best solution possible for a given set of assumptions and data. This statement applies, of course, to global optimisation with a given model. By using new powers of computing, new solutions for logistical problems can be considered which were practically impossible before. Optimisation can handle economies of scale and capacity constraints on the facility in a logistics system and helps to reduce costs or increase the profit.

Optimisation also has some disadvantages too:

Its greatest disadvantage is that it cannot be used for the full range of logistics decision problems [Powers 1989]. The optimum global solution is not

possible for problems of a realistic size, Powers [1989]. Often optimisation models are so highly idealised that a model solution is not completely consistent with the problem environment [Ballou 1989, Bowersox 1989, Powers 1989]. Logistics managers do not understand some of the finer points of decomposition methods or the simplex algorithm [Powers 1989]. While optimisation techniques are quite useful for obtaining an unique optimal solution, computational requirements make them unsuitable for solving large problems in logistics.

6.1.2 Simulation

The label simulation can be applied to almost any attempt to replicate a situation. Simulation is a process by which a model of a particular situation is developed and tested using the known facts [Bowersox 1989]. Simulation provides the ability to operate some particular phase of business on paper or in computer for a period of time, and by this means to test various alternative strategies and systems [Shycon et al 1960]. Ballou defines a simulation as "a mathematical description of a decision problem, usually in significant detail. The mathematical description is typically manipulated with the aid of computer due to the burdensome computations required. Problems are solved by "costing out" various alternatives as replicated by the simulation. Repeating the simulation numerous times produces the cost profile for the various alternatives from which the most desirable one may be selected" [Ballou 1989]. There are two type of simulations, static simulation and dynamic simulation.

The fundamental difference between static and dynamic simulation rests on time inter-relationships. A model is static if it deals with time periods with an exclusive basis with the system in equilibrium during analysis. For example, a static model may replicate system performance over 13 four-week periods during an operating year. As such, a model would cover an extended time horizon. The modelling is static if each of the time periods is treated

independently.

If the time periods are linked in a manner wherein one time period's performance can influence the next time period's, then the model is dynamic [Naylor et al 1966]. The 13-period replication is dynamic if each of the time intervals is linked on a recursive basis with linkage accomplished by feedback mechanisms.

Simulation is typically applied in logistics in one or two ways: firstly, as a tool to identify and evaluate improved operation performance, and secondly as a tool to obtain a better understanding of the cost and performance potentials of a logistics operations [Bowersox et al 1989].

The main advantages of a simulation:

At the technical level, the distinguishing feature of simulation is its capability to include stochastic situations. In most logistics planning situations, uncertainty and resulting variance are significant considerations. Simulation technologies are capable of incorporating variance across either a dynamic or static planning horizon. In other words, probability can be introduced into analysis dealing with a specific point in time problem (warehouse location) or across time (inventory/customer service relationships). Since simulations can deal effectively with uncertainty, they are used extensively for problems requiring both a time and space integration such as network inventory. Simulation will provide merely the best answer of the solution tried [Mentzer 1989].

When the nature of the logistics problem dictates the data at the lowest level of details, simulation may be the only way to gauge the effects of different decisions [Powers 1989].

As many companies cannot undertake a sweeping revision of their logistics

systems, in cases where there are a limited number of alternative options, simulation is very useful for providing comprehensive modelling details [Rosenfield et al [1985].

As in any other techniques, the simulation also has disadvantages too;

The results of simulation models which deal with uncertain events must be viewed as only estimates subject to statistical error. The model building, data collection and results analysis required to perform the simulation are likely to be very difficult; simulation can bury a modeller in data [Wagner 1969]. Simulation techniques cannot provide precise solutions [Bowersox 1978]. It requires a great deal of computer time and data collections.

6.1.3 Heuristic

The word "heuristic" is derived from the Greek "heuriskein" meaning "to discover"; a heuristic aims at studying the methods and rules of discovery [Polya 1947] or to assist in problem solving, which is a process systematically trying to attain a preconceived but not immediately attainable aim [Polya 1962,1963]. Operational researchers have seen heuristics as a procedure to reduce search in problem-solving activities [Tonge 1961] or a means to obtain acceptable solutions within a limited computing time [Lin 1975]. To practitioners, heuristics are simple procedures, often guided by common sense, that are meant to provide good but not necessarily optimal solutions to difficult problems easily and quickly.

More specifically a heuristic is a short cut process of reasoning that searches for a satisfactory, rather than an optimal, solution. The heuristic which reduces the time spent in the search for the solution of a problem, comprises a rule or a computational procedure which restricts the number of alternative solutions to a problem, based upon the analogous human trial and error process of reaching acceptable solutions to problems for which optimizing algorithms are not available [Hinkle 1967].

A heuristic modelling solution uses "rule of thumb" procedures developed from basic knowledge of the problem [Bowersox et al 1989].

Heuristic's advantages are:

The use of heuristics in solving problems attempts to maintain the level of problem description detail of simulations while offering the best solution search capability of optimisation approaches. Heuristics are rule of thumbs that direct the solution approach toward the best solution, but do not guarantee that it will be found [Ballou 1989]. Properly used, heuristics would allow near optimal or optimal solutions to be found in a fraction of the computer times required for optimising approach [Ballou 1989].

A typical heuristic procedure is designed to improve managerially acceptable solutions [Bowersox et al 1989].

Heuristic models provide greater ability to replicate complex problems than optimisation. They have the ability to find the solution among many possibilities compared to simulation models.

Heuristics can be used to find the starting point for optimum solution.

Disadvantages of heuristics are:

it does not guarantee an optimal solution. It does not consider the capacity constraint and fixed cost on optimum basis, although it does handle them on the rule of thumb basis.

6.1.4 Comparisons of Operational Research Technique

Atkins et al [Atkins et al 1968] summarize the ideal technique required by management scientists and what each operation research technique has to offer.

Ideal technique

In an ideal technique there should be no restriction on the number of plants, warehouse sites and customers.

Optimisation

In addition to practical limitations in terms of the time and cost, numbers can also be limiting factor.

Simulation

There is, in effect, no theoretical limit to the size of problem that can be handled by simulation.

Heuristic

As, with simulation there is no theoretical limit to problem size. However the nature of heuristics presupposes the use of more discretion in screening out unnecessary details.

Ideal technique

An ideal technique would represent explicitly any significant production or storage capacity limitations.

Optimisation

The capability to deal with capacity limitation is one of the most important capability of optimisation.

Simulation

In simulation, capacity restriction can be considered on an empirical or rule-of-thumb basis rather than on optimal basis.

Heuristic

Capacity constraints can be considered on the rule of thumb basis, rather

then on an optimal basis.

Ideal technique

An ideal technique would be broad in scope, to include such things as the impact on inventory requirements and customer service.

Optimisation

Another important capability of optimisation is the facility it provides for dealing with complex interaction between functions and between products in broad scope application.

Simulation

There are theoretically no limits to the possible scope of a simulations model.

Heuristic

Theoretically there is no limit to the scope of a heuristic program. But there are practical limitations, primarily in terms of development and computer running time.

Ideal technique

Ideal technique may wish to reflect day to day scheduling problems, particularly in those situations where customers are supplied along continually changing distribution routes.

Optimisation

In general optimisation cannot be used effectively to analyze complicated scheduling problems.

Simulation

Simulation is probably most useful where scheduling factors are a major concern. There are in fact many situations where scheduling is a such a predominant factor that simulation is the only reasonable alternative to

conventional methods.

Heuristic

Practically, heuristic programming is unlikely to be used in situations where scheduling is important.

Ideal technique

An ideal technique would like to provide an optimum solution taking into account all of the above factors, plus the timing of investments, as well as plant and warehouse costs which may reflect increasing economies of scale.

Optimisation

Optimisation does provide the optimum solution but problems cannot be modelled in great detail.

Simulation

The inability to proceed systematically to an optimum solution is perhaps the main drawback of simulation. One never knows how much additional improvement is possible.

Heuristic

Optimum solutions cannot be guaranteed, but computer-based procedures search automatically and systematically through possible decision alternatives in order to find better solutions. It normally produce better solution than simulation solution.

Ideal technique

Ideal technique would like to achieve all of the above objectives to the maximum possible extent in the shortest possible time and at the lowest possible cost.

Optimisation

Optimisation is one of the most sophisticated tools of management science in terms of the need for experienced, trained personnel. It is therefore expensive if it is to be used properly.

Simulation

Using simulations models for facility location planning can be expensive and time-consuming undertakings.

Heuristic

Some "canned" procedures have been developed which can be used at relatively low cost.

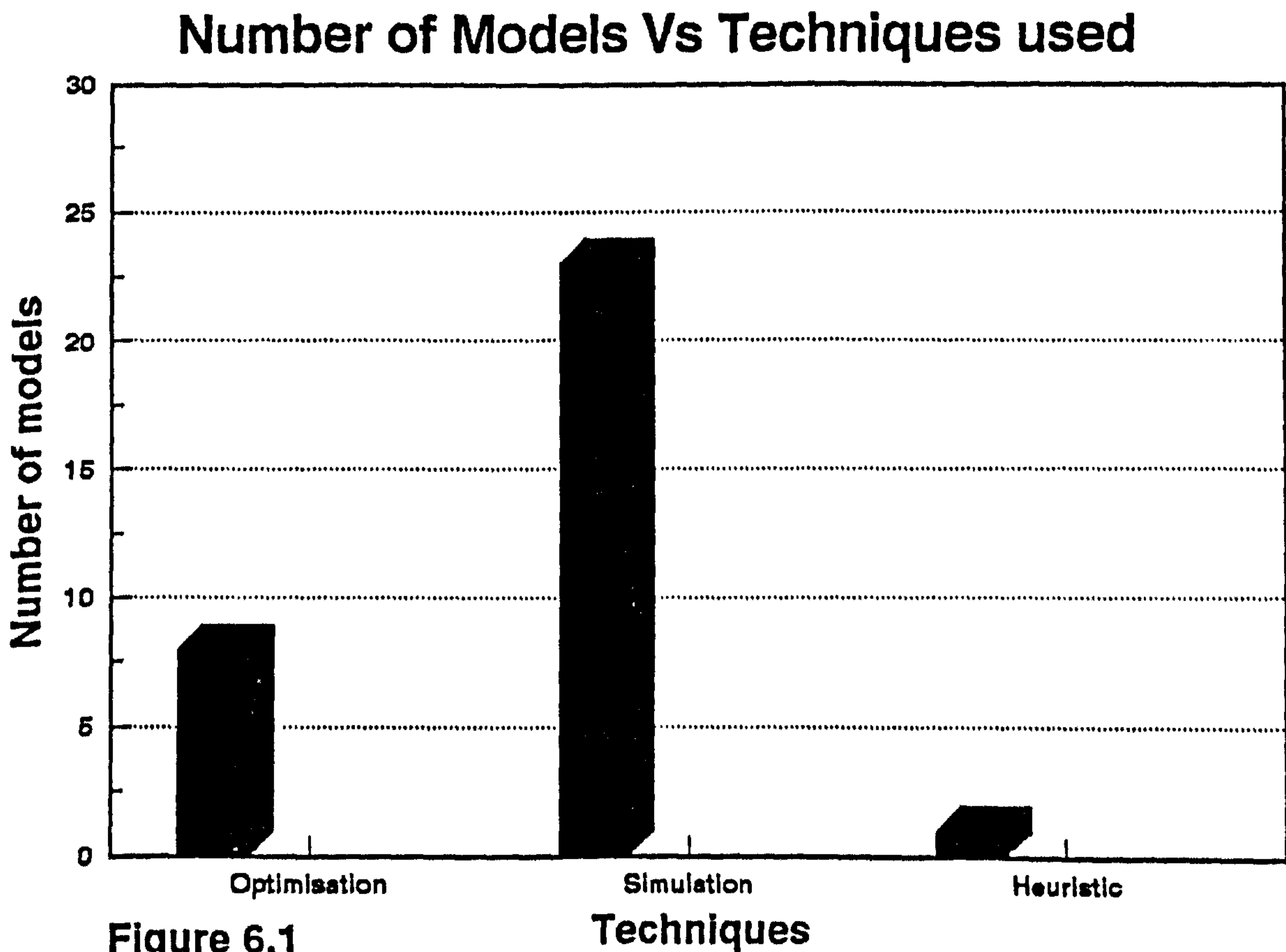

In figure 6.1, Mentzer et al summarize the number of different techniques that have been used to develop logistics system design models [Mentzer et al 1982]. Simulation is most widely used, for the reason that all the models details were needed to be included to convince the manager that these results

are derived from their data. Optimisation is the other technique most widely used to find the best possible solution. The heuristic technique is not much used in model development as the developed models are not very user-friendly to perform "what if" analysis.

6.2 Mainframe Vs Personal Computers

Mainframes and personal computers are quite different in their design, capabilities and limitations. Whereas mainframes are designed to handle large amounts of data and input from numerous sources, personal computers are designed to handle smaller amounts of data from one input source at a time.

The advantages to modelling on the mainframes are that they are designed to handle large amounts of data and provide a large capacity for central processing. They have the attraction of seemingly immense solving power. This means the large amounts of data and considerable size of program needed for distribution modelling can be easily accommodated. Furthermore, in some companies the distribution data needed for modelling purposes is usually stored on the mainframe and is therefore directly accessible by the model.

The disadvantages to modelling on the mainframe arise from the fact that many people use the mainframe for many purposes. This time-share nature of most mainframes often causes considerable delays in accessibility to the planning models by distribution managers. A general lack of accessibility to the mainframe by distribution managers often makes the distribution planning model seem to be something in the realm of computer people and thus something to be used less often. Furthermore, computer time on the mainframe, especially on time-shared systems, is costly. The longer the model takes to run and the more often it is run, the more the cost charge to distribution.

So far experience has shown that whatever has been developed on a mainframe will eventually work its way down to micro. However, the pace of evolution on the micro-computer is faster than that on the mainframe. For example, project management software, which was developed over a 10-year period on mainframe, went from simple to sophisticated on the micro in a three-year period [Bodily 1986]. In recent years micro-computers have become recognised as extremely useful computational environments, in part because of their surprising power [Carlisle et al 1987]. For example, Harrison compared the IBM PC-XT to a small mainframe (IBM 4381) and showed that microcomputer was only 40 times slower for broad class of nonlinear programming problems [Harrison 1985]. A belief persists, however, that the larger problems in logistics still belong on a mainframe. While this is certainly true to a degree, Carlisle et al showed that a full-scale logistics study, including network design problems with over 20,000 links, can be handled entirely on a microcomputer, and that the microcomputer can actually produce faster turnaround times than a mainframe [Carlisle et al 1987].

Personal computers allow the manager access to and the use of a planning model directly on his or her own desk without any delays and no access charge for long run and multiple uses. In addition a wide variety of software has been developed specifically for use on personal computers. An entire industry has evolved that is developing software for personal computers. This provides the managers with far more user-friendly, flexible, application oriented software for personal computers than exists for mainframes. The personal computers allows the distribution manager to have access to the planning model in numerous locations. Anywhere a personal computer is available, the model can be accessed and used immediately. The most important of all is that the low cost of personal computer hardware allows many small companies to afford distribution planning with models which can be used by many more people at many more locations than it is possible with a mainframe.

Blumenfeld et al described the personal computers as a very powerful medium. They can reduce system development time and costs, and have "front load" system benefits, enhancing the system's appeal. For TRANSPART (chapter five), being programmed on to a personal computer was the key to gaining widespread corporate usage [Blumenfeld et al 1989].

Raugh et al state that lack of mainframe availability started out as a reason for their decision to use a PC, but in the long term it turned out to be a definite plus because:

- a) a micro-computer has enough solving power if the model is well written;
- b) the scope must be such that the underlying financial model is accurate;
- c) the complexity and resolving power that can be supported by a micro-computer are also more than adequate [Raugh et al, 1987].

Carlisle et al stated that they chose microcomputer for the following reasons:

"It offered independence from any mainframe standards of the management information systems department. The commitment to specific hardware enabled the use of an extremely user-friendly environment including full screen editing, graphics, cursor controlled choices, colour reports and so forth. Special low cost and powerful packages could be used as a part of the system. These include Data base III for data manipulation and ATLAS for graphical representation. Use of a microcomputer is virtually free in terms of today's hardware costs. The model can be installed on several machines to allow several analysts to look at different questions independently." [Carlisle et al 1987].

Mentzer stated in an article that personal computer were not intended to replace the mainframe and will not do so in the foreseeable future and he reached the same conclusion regarding personal computer-based distribution planning models [Mentzer 1985]. This statement is no longer true because of

the introduction of OS/2 and other operating systems which are eliminating the 640K upper limit of DOS (Disk Operating System) for programming; personal computers are now replacing mainframe computers in distribution systems. All the state of art software (see chapter five) which used to be run on the mainframes are being converted to run on personal computers.

The personal computer-based distribution planning models offer flexibility, accessibility, and time and cost savings that mainframe cannot match. The most important aspect of personal computers is that they are taking the power of information technology to fields where one never imagined it would ever reach.

6.3 Computer Graphics

If graphics reveal data [Tufté 1983], then interactive graphics explores data [Kornhauser 1987]. Interactive computer graphics provides a medium by which the human mind can inquire, learn, understand, and be creative. The interactive aspects provide the feedback element that "close-the-loop" between the mind and data. With interactive computer graphics the graphics become not only an output device but also an input device. Thus graphics become a two-way means of communicating with the data, it becomes a data base manager. Since the concept of data can also be expanded to include mathematical and logical transformations or models, the concept of interactive computer graphics as a database manager encompasses all form of data exploration including alternative analysis. Viewed in this light interactive graphics becomes an heuristic environment for "solving" intractable optimisation problems. With such an environment, the user can explore the data to better understand problems, sharpen questions and issues, and evaluate and rank alternatives. The ability to explore the data allows certain problems to be analyzed quantitatively that otherwise would have been left unsolved, [Kornhauser 1987].

In seeking the best compromise solution, planners and decision makers in

logistics systems need an improved means of information transfer that will result in a better understanding and evaluation of various alternative plans and their economic, environmental and institutional impacts. To reduce the communication barriers and to speed up the process of logistics planning, interactive computer graphics technique may prove to be quite useful. Computer graphics provides a relatively rapid means of inputting spatial data and can display, in pictorial, graphical or tabular form, intermediate and final results of model computations. An interactive conversational system incorporating computer graphics allows real-time interactions between analyst, decision maker and other concerned parties.

When operational research techniques and computer graphics are combined, a new modelling approach is formed, known as Visually Interactive Modelling (VIM)(chapter three).

Graphics in general have been claimed to "bridge the communication gap between the top executive and the computer" [Miller 1969]. The visual interactive model consists of interactive graphic procedures in which decision makers can influence the solution by suggesting or forcing some choices, such as location for facilities or allocations to facilities. This type of methodology is particularly well suited to location-routing problems. Visual interactive modelling uses the power of computer graphics to aid managerial communication with an operation research model. The visual interactive model provides a new look at old problems. The use of this type of model can increase the problem owner's involvement at the problem formulation stages. A visual interactive model communicates with the decision maker through a visual model. This visual model is an extremely powerful vehicle for representing decision situations. Visual interactive model provides the opportunity to use very sophisticated O.R techniques in a friendly and easily understood environment. The decision maker can accept the gaudiness from these techniques, but at the same time may override the model suggestion when other criteria, outside the model, become important.

The visual interactive problem solving methodology that separates design of the visual model from development of the mathematical model offers several advantages to the manager. The problem owner can understand a visual model more easily than a mathematical model, can effectively contribute to its development and can thus exert an impact at the formulation stage. By seeing the model solution through the medium of screen display and interactions, the manager can assess the value of the model very early in the development. If, however, the model diverges from the expectations of the manager then this leads to direct communication between the analyst and the manager. Either the model is correct, in which case the manager will learn from situation, or the model is logically incorrect. If the latter is true then the manager can usually state the logical inconsistency in the model, since he is watching dynamic visual representation. At the next interactive session with the inconsistencies rectified, the model soon ceases to be an analyst's model and becomes the manager's own management model. This observation has occurred on all management visual simulation developed to date [Harrison 1980].

A different view sees the VIM as a vehicle to help the decision maker resolve semi-structured problems. This arises from the obvious similarity between many VIMs and Decision Support System (DSS) [as described by Keen et al 1978]. The view of a VIM as a DSS results in an emphasis on the VIM display and interface being tailored to the decision maker, and the inclusion of extensive data management facilities and perhaps several mathematical models within a single VIM.

VIM with dynamic iconic graphic displays is seen as particularly useful in revealing the working of a simulation model to the decision maker. The dynamic visual display enables the non-specialist to judge the correctness or otherwise of the modelling representation directly [Crookes 1982].

6.3.1 Survey of Visually Interactive Models

Kirkpatrick et al conducted a survey on visual interactive models to answer the following question:

- (i) Who the visual interactive model builder or users are;
- (ii) The type of problems being addressed;
- (iii) Why visual interactive modelling is being used;
- (iv) How visual interactive model effects problem solving; [Kirkpatrick et al, 1989].

(i) The majority of users in the sample were in businesses that involved fairly complex system, primarily in the manufacturing sector (45 percent) and the software consultancy sector (29 percent). The majority, 60 percent, worked strictly in-house.

The people who were using the visual interactive models were:

57 percent operational research;

24 percent engineer, and research and development;

19 percent other.

The other important factor is over 75 percent of the systems were on the micro-computer.

What type of problem is being addressed?

Task Description	Ranked 1	Ranked 2	Ranked 3
Capital investment	33 percent	23 percent	
Operational Control	15 percent	35 percent	
Long Term planning	10 percent	23 percent	
Short term facility	10 percent		33 percent
Planning			
Budgeting, Resource			

allocation, and

other 32 percent

The most common modelling technique used was event-based simulation (93 percent). Heuristics was the only other technique.

What are the most important reasons for using VIM?

The problem involve large number of dimensions, making it more a model of a system than a model to solve a simple problem.

58 percent most

24 percent 2nd

18 percent 3rd

The problem entailed finding a best combination of levels of different objective;

18 percent most

36 percent 2nd

46 percent 3rd

The decision rules are not static;

6 percent most

62 percent 2nd

32 percent 3rd

A group will be responsible for choosing the solution;

11 percent most

33 percent 2nd

56 percent 3rd

The recommendations of our group carry a lot of weight with management;

33 percent most

11 percent 2nd

56 percent 3rd

The decision makers do not understand mathematical model;

38 percent most

53 percent 2nd

9 percent 3rd

Some important dimension of the problem could not be measured using a meaning full numerical scale;

53 percent most

8 percent 2nd

39 percent 3rd

How VIM affects the problem solving;

There was fairly general agreement that a visual interactive model takes longer to build than a traditional mathematical model, but several claimed that the total time required to solve a problem decreases because less time is needed to discuss the model and assumptions with the decision makers [DeSanctis 1984, Melamed et al 1985]. This view was supported by 88 percent of the respondents who reported that this stage of the process went faster or much faster;

The validation of the model with the user went much faster and faster.

20 percent responded faster model building debugging and analysis of alternative as major benefits of the visual interactive modelling to the modeller; 42 percent indicated that project required additional resources; 14 percent indicated that there was faster decision making.

The major benefit of using VIM has been claimed to be enhanced user understanding of various aspects of the problem or the mathematical techniques used [Hurrion 1980,1985,1986, Fiddy et al 1981];

The graphics alone contribution to the modelling understanding were:

moderately -	33 percent;
greatly -	43 percent;
incredibly -	14 percent;

The most common benefit to the decision maker were:

- a better understanding of the problem and the alternative available - 74 percent;
- the decision maker greater confidence in the model and its response - 44 percent;
- better resulting decision - 11 percent.

The major advantages of VIM to the modeller were:

- an improved understanding of the modelling technique and results on the part of the decision makers - 72 percent;
- the decision maker's greater confidence in and commitment to the results - 35 percent;
- better understanding of the problem and the model on the part of modeller - 25 percent.

Problem Solving Process;

When the people were asked about increased interaction,

98 percent responded that they felt that Visual Interactive Model was better for decision makers;

88 percent said they understood the system better because of the interaction;

83 percent responded that they understood the decision problem better.

The resulting solution:

VIM can affect the solution to the problem in two ways. First the interaction between the model builder, the decision maker and the model as it develops may change the definition of the problem as modelling progresses.

60 percent of the respondents stated that results were affected because due to visual interactive models;

72 percent said that result was that they built and used a different model;

65 percent felt that the solution arrived at was different because Visual Interactive Modelling had been used for analysis.

6.4 Models for the Nineties

A major benefit of visual interactive modelling has been stated to be its value in selling O.R. solution to a management that attached low credibility to modeller [Kirkpatrick et al 1989]. The other benefits of visual interactive modelling to managers are in model validation [Hurrion 1980; Fiddy et al 1981; Bell 1985; Bell et al 1985]; in group decision making [Hurrion 1985]; and in incorporating qualitative dimensions into quantitative models [Bell 1985]. The logistics models for the nineties should be visually interactive to take the advantages of the above benefits.

Blumenfeld et al stated that they learn the following lessons from their study:

"It is worthwhile to pursue results that allow simple decision models and principles to be developed. Formulating models that are simple functions of a few key parameters with clear physical interpretations help make decision tools transparent and meaningful to potential users. Transparency is

important because decision makers justifiably want to understand the logic underlying decision tools"

[Blumenfeld et al 1989].

Regarding decision tools development, they learnt that tools evolving from vigour of management science methods are more likely to be used if they do not require user to have sophisticated skills. Such tools should focus on quantifying trade-offs between key variables, using a minimal amount of data, facilitating sensitivity analysis and presenting the solution graphically. They should aid in evaluating several options and highlighting the implications of decisions that are practical alternatives to optimal solutions. In this way if for practical reasons an optimal solution cannot be implemented the user can identify numerous options that are feasible in practice and nearly optimal [Blumenfeld et al 1989].

Models for the nineties should be hybrid in technical terms because each method or procedure is best suited to a particular requirements [Ballou 1989, Powers 1989, Bowersox 1989]. It should be able to use simulation details for modelling purposes which will convince the user or manager that the model is modelling their system. It should use the optimisation for building a allocation network from market areas to production plant or in some cases to the source materials. It should be able to provide cost for different strategies of distribution system, which may be achieve by using heuristics. It should be able to run on personal computers, the advantages of which have been described in a previous section. It should be user-friendly and utilise the user-friendly and explanatory power of high resolution computer graphics, as 'one picture is worth more than a thousand words'.

In short the model for the nineties should be a prototype, user-friendly, simple, visually interactive, logically correct model that runs on a PC, and is a pleasure to use.

6.5 Conclusion

The advantages and disadvantages of each mathematical technique have been defined and discussed. Mentzer's survey reveals that logistics planning models were developed either by using very detailed data for which simulation is being used or by looking for an optimal solution [Mentzer et al 1982]. The availability of computer graphics will help to use the heuristic technique and new modelling techniques such as visually interactive models. Kirkpatrick's survey clearly demonstrates that visual interactive models are better for decision makers and sometimes a particular solution was only achieved by using a visual interactive model [Kirkpatrick 1989]. System complexity is most frequently cited as the main reason for using visual interactive modelling. Other reasons include the multiple objectives, qualitative factors, and dynamic decision rules. Blumenfeld et al also concluded that models should be simple, use minimal amounts of data, present solutions graphically, and be able to evaluate several options [Blumenfeld et al 1987].

As described, each operational research technique has some advantages and some disadvantages. In section 6.1.4 the ideal techniques required and what each technique is able to offer was discussed. For the development of an ideal model, it is necessary to take the best from each technique and combine them to form a new technique, thus developing hybrid techniques. It should be able to use the optimisation for allocation, to handle the production constraint at plant and throughput constraints on depots and use heuristic with computer graphics to locate the depots at best possible place.

Chapter Seven

Description of the Model

7.0 Introduction

In this chapter, the adopted approach to LSM development and the reason for its adoption will be discussed. The discussion will also be focused on the model structure and its algorithms. The details of distance calculation by using latitude and longitude will be given. The LSM allocation algorithm and its advantages will be described. The model's other capabilities, such as the ability to identify the best possible location for a depot and the modification and zooming facilities, will be fully described.

7.1 Model Development Approach

The distribution software presently available to logisticians has been described in chapter five. The software which will be used in the nineties, the advantages and drawbacks of operational research techniques have been discussed in chapter six. One practical way to set the criteria for the model design is to base it on the ideas of those that must implement the model results. Ballou suggested the following criteria for model development:

"Models which forsake too much problem scope and detail for mathematical refinement are likely to have their results disregarded by practitioners. Data requirements and the cost of running the models are the next most important factors. Optimisation in the purest mathematical sense is frequently of least importance to practitioners. The realities of the location problems are that exact procedures offer little benefit in practice over good heuristic approaches. In addition, heuristics allow all relevant costs in their proper form to be included whereas exact procedure that cannot deal with all relevant costs may find optimal solutions on an irrelevant total cost curve. Managers look for improvements in their existing operations and rarely implement the mathematically optimized model solution. The model is used to provide an understanding of problem sensitivities and directions in which the

distribution system might be changed to offer cost improvements. The proper economic analysis of network designs requires that all relevant costs be balanced to achieve the minimum cost configuration of facilities."

[Ballou 1989]

This is why LSM uses heuristic techniques for establishing the best possible location of a depot.

The Logistics Strategy Model (LSM) was developed using a combination of the powerful computer language FORTRAN 77 and a computer graphics package HALO. It is computer graphic visual interactive, and capable of modelling any part of the world. It runs on any IBM AT compatible personal computer. It operates under DOS (disk operating system), with colour monitor (preferred) and EGA (Enhanced Graphic Adopter), VGA (Video Graphic Adopter), CGA (Colour Graphics Adopter) or Hercules graphics cards. The use of a maths co-processor and hard disk increase the speed of allocation and search procedures. However it can be run from the floppy disk and without a maths co-processor.

Although the advantages of Fortran were given in chapter four, the following may also be added regarding its use for LSM. It is still the best language to handle numbers and mathematical calculations and is therefore widely used for developing computer models in the logistics industry. Most of the models reviewed in chapter five such, as DSS and Stradis, were developed using Fortran.

HALO, the computer graphics package was used to make the LSM machine independent. Earlier visually interactive software packages were machine specific, which was their major drawback for wider application. Because it uses Halo, LSM is able to run on most of the computer graphics boards available in the market.

The model is computer graphic visually interactive, the advantages of which have been given in chapter six. The main reason for this was to overcome the black box syndrome. However Schmidt also described the following advantages for using a computer graphics approach for computer mapping:

"By and large man is a visual creature, perceiving the world as a images, and images in turn are associated with characteristics for which he has a particular reactions. The image comprises pattern, which have boundaries, and which humans interpret by comparisons with memory. Computer mapping is a construction of geographical images which gives salient information, produced quickly and presented cleanly. It promotes communication among man and machines, making optimum use of the capability unique to each. "

[Schmidt 1978]

The computer mapping is a important component of LSM.

LSM runs on micro-computers, because more companies in the distribution industry have access to micro-computers than to macro-computers [Mentzer et al 1990]. The micro-computers are much more user-friendly and cost much less than macros. These and other comparisons of micro- and macro-computers are given in chapter six.

LSM is able to operate with and without a maths co-processor. The use of a maths co-processor makes allocation and searching for the best possible location about five times quicker. However, as not all micro-computers have maths co-processors, LSM is able to operate without one.

One of the major reasons for developing distribution models on mainframe computers was that a mainframe is able to model for a very large number of customers, depots, source points and different products. Theoretically it is an excellent idea for a model not to have upper limit constraints. But most

models are developed for practical applications and most companies have reasonable numbers of customers, depots and source points. LSM is able to model concurrently ten different groups of products (product for this model being defined as individual items which have the same local delivery, trunking and inventory costs), ten factories or source points, eg ports or airports, fifty distribution depots and transshipment points and one thousand customers, and still operates within 640K DOS limits.

The use of real distance for modelling distribution systems has been advocated strongly in the models reviewed in chapter five. The applications of real distance is particularly beneficial for routing and scheduling models. The advantages of employing real distance become more apparent when operational systems are simulated. However, in a model which is developed for strategic distribution modelling on the philosophy of LSM, real distance may have some major drawbacks such as:

- the limited availability of real distance data, particularly in the underdeveloped world;

- the amount of data required to model the distribution system;

- each time a depot is moved in a search procedure, its distance from all serving area will need to be given.

LSM uses a straight line distance for local delivery and trunking. It converts straight line distance to approximately real distance by using a wiggle factor. It uses two different wiggle factors, one for local delivery and the other for trunking delivery. To approximate real distance as accurately as possible, LSM incorporates hazards for congested areas and poor road networks and barriers for rivers and mountains and takes into account extra distance which may result from their presence in the modelling area. In strategic modelling, where most of such data as future demand, and labour and facility costs, are

based on forecasting, the above-calculated distance will be sufficient for cost calculation.

Costs for a logistics system are discussed in chapter two. LSM is a cost-driven model and its developed distribution network structure strongly depends on the relationship between various costs. It takes into account the following costs:

- trunking cost from factory to distribution depot;
- trunking cost from depot to satellite depots;
- local delivery cost (from distribution depots or satellite depots to customers and market areas);
- distribution depots or satellite depots fixed and variable costs;
- inventory carrying costs for all the products at each distribution depot (satellite depots do not hold the inventory).

LSM does not include the product's production cost or inventory costs at the production plants.

For "what if" analysis, the user is able to modify most of the data within the program. This makes LSM much easier to use, and encourages the user to use "what if" facility and compare the different distribution strategies.

The model data preparation is an important stage in logistics modelling. Models which do not have user-friendly data preparing facilities may not be chosen by users. LSM can read the files which are created by using Wordperfect or any other word processor which is DOS compatible. It can also read files created by any software which is able to saved in DOS. LSM has its own visually interactive facility which may be used to create the database files, and its output data can be read using Spreadsheet's excellent business graphics capabilities. These extra functions makes LSM an attractive software model for the distribution industry.

The overall structure of the model is shown in figure 7.1, and the its working structure in figure 7.2.

7.2 Map Display

Details of different map projections and some examples of projected maps have been discussed in chapter four. Also discussed in chapter four were different graphics coordinates systems which are being used to display the maps. LSM uses the world coordinate system and makes optimum use of the screen to display a map. While the VDU (visual display unit) screen is a rectangular shape, the country, area or region to be displayed is rarely rectangular. Therefore displaying a map on the screen is different than displaying it on paper. One way of overcoming this problem is to define a area on the screen in which the map can be displayed. This technique is being used by Spreadsheet for output graphics and is very useful for business graphics such as pie and bar charts. This approach is also useful for comparative graphics. The main disadvantage with this approach is that the screen is not used optimally. This is a major drawback for a model which puts a great deal of emphasis on the visual representation of information, and decisions are being made by observing these representations. The scale and techniques which are used to display and draw the maps on the screen comprise a new subject in computer graphics, known as computer cartography.

As described above LSM employs the world coordinates to display the map, which are user-defined. Another approach would have been that the program reads the map's data base file and takes the least value of X as a minimum value of X-coordinates and greatest value of X as a maximum value of X-coordinates and do the same for the Y axis. This approach would produce a distorted map on the screen. Therefore to define the proper shape of the map requires a trial and error process to define the world coordinates. The user must carry on changing the world coordinates until the right shape for the map is found. The data of the map file could be in either kilometres or

Logistics Strategy Model

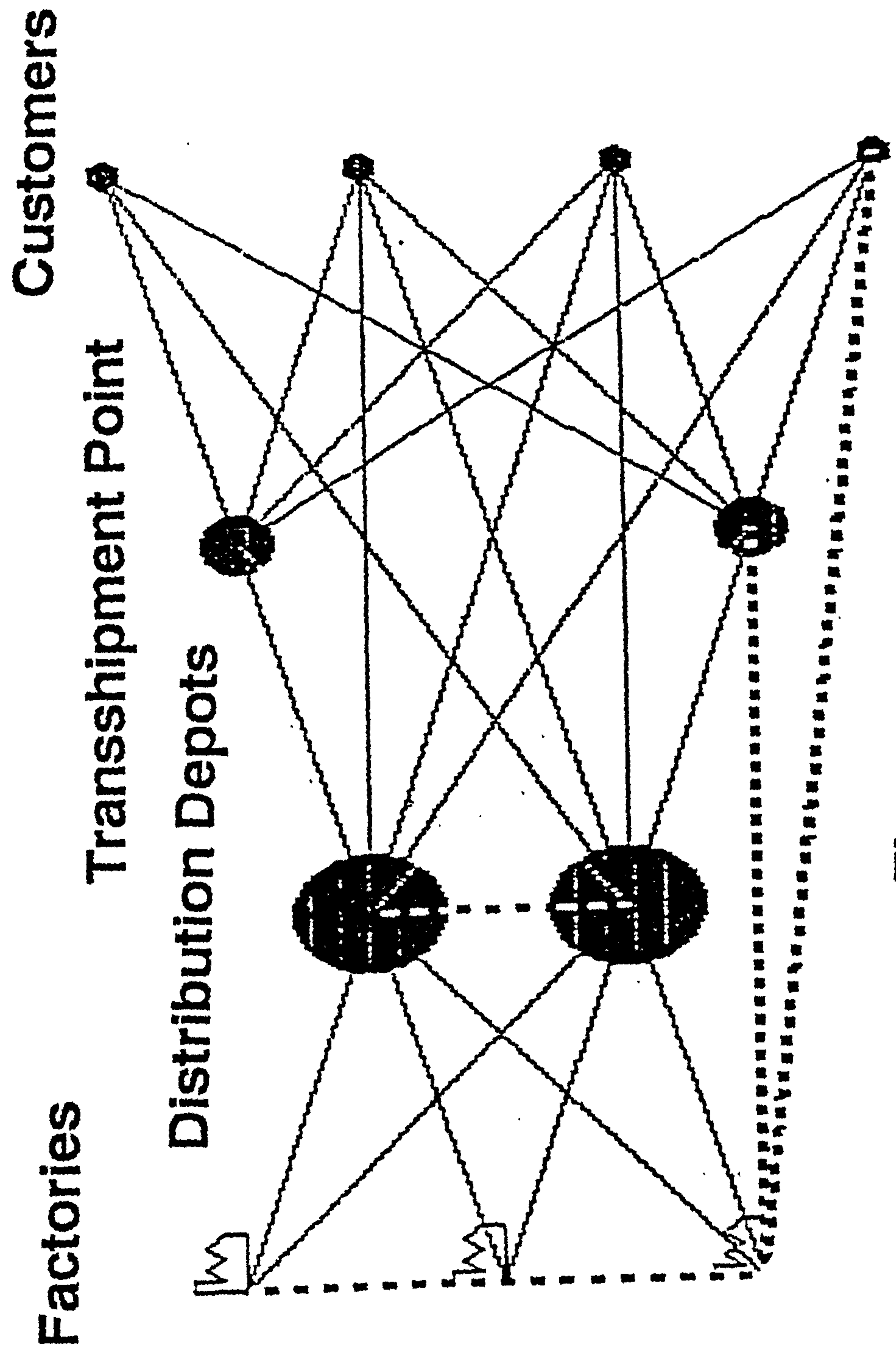

Figure 7.1

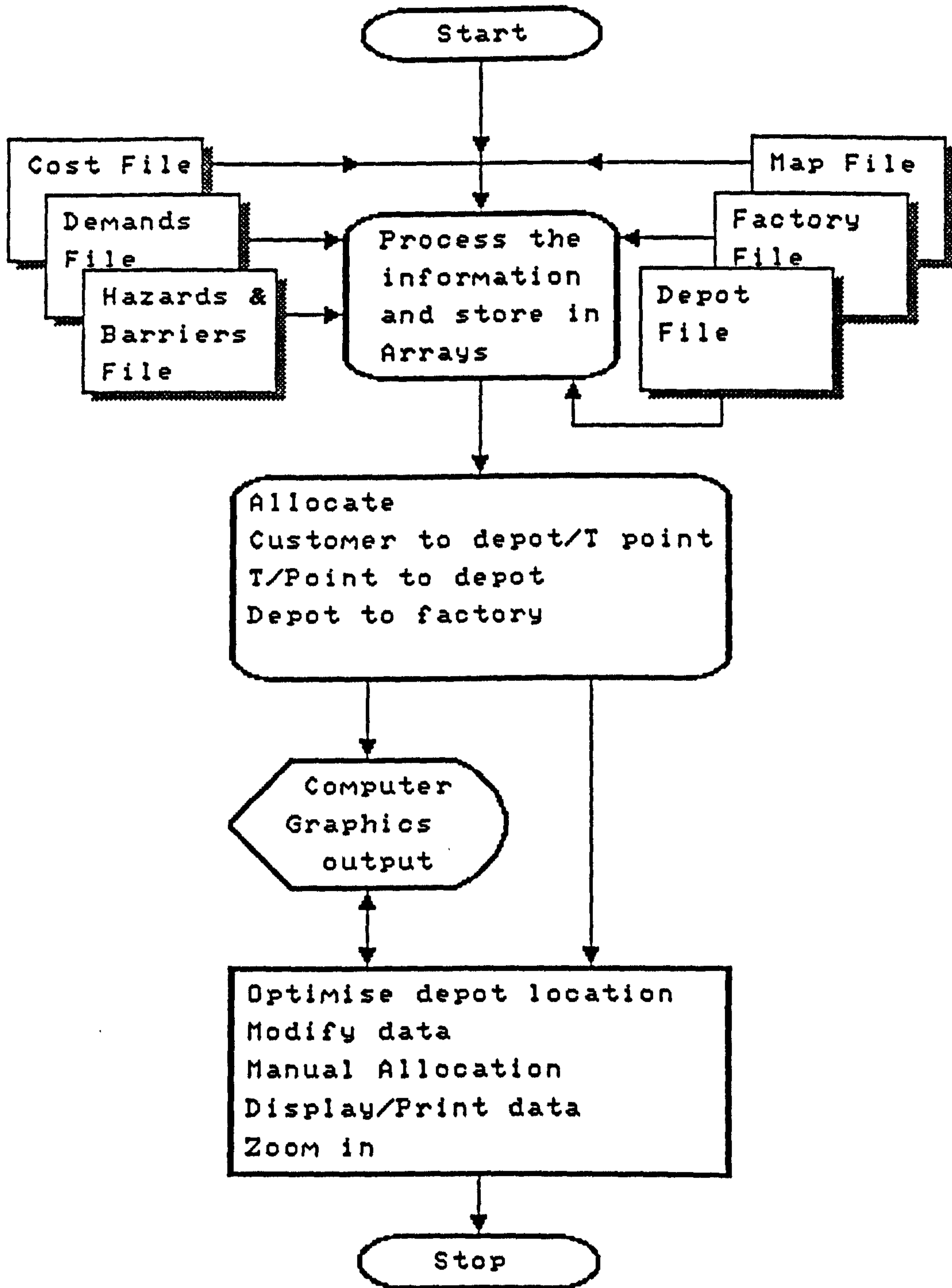

Figure 7.2 LSM working structure

latitude and longitude.

LSM uses the Jones' nth point algorithm [Jones 1985] to draw the map on the screen. This algorithm involves selecting the first and every subsequent nth point from the original line, and is notable for the fact that it pays no attention to the shape characteristics of the curve. It simply draws a straight line from one point to the next, without taking into consideration of any other points. To achieve the curve shape for a map from this algorithm, a great number of points are required in the curve area.

Once the map has been drawn on the screen, the user can store the map by using the Halo graphics image storing function. The storage map can be retrieved for displaying at any time during the program or next time when model is being run.

LSM uses different colours and legend to display different object on the screen. The blue colour is used to represent the sea area on the map. The factories are drawn in purple, transshipment in green, distribution depots in red and customers are in yellow. If more than one country is being drawn, boundaries will be represented in a different colour.

LSM does not display the roads network and rivers on the screen. The displayed information is kept to a minimum to ensure precise and clear presentation for decision making. Once the soft copy of a map has been produced on the computer screen, there is no guarantee that same shape of the map will be produced as a hard copy. The output of a hard copy depends on the relationship between the computer graphics software package and the particular printer or plotters (chapter four) is being used for output. The output copy is affected by the resolution and font of the printer. This is why different hardware was discussed in chapter four.

LSM has been used to design European, British and Pakistani logistics

strategies. The maps of these countries were drawn by using the LSM map drawing facilities, and are shown in the model validation chapter (chapter 9).

7.3 Distance Calculation

The importance of using actual distance has already been discussed. The reason for LSM using the straight line distance are also given.

Any logistics strategy model which attempts to model different logistics systems in different parts of the world faces the problem of distance calculation. There are not many countries in the world which follows the example of the Ordnance Survey maps of the United Kingdom, which divide the country into a ten kilometres square grid. However, there are systems such as latitude and longitude which are available on the world wide bases and can be used to calculate the distance. Here, however, there is the well known problem of the world's curvature (chapter four); one degree of longitude represents differing distances (eg kilometre or miles) at different latitudes.

7.3.1 The Great Circle Formula

The shortest distance between two points is a straight line, but on the earth it is impossible to follow such a straight line. The shortest "straight line" course over the surface between any two points on the sphere is the arc on the surface directly above the true straight line. This arc is formed by the intersection of the spherical surface with the plane passing through the two points and the centre of the earth. The circle established by the intersection of such a plane with the surface divides the earth equally into hemispheres and is called a great circle [Robsinon et al 1969]. The formula which is used to calculate the distance between two points on the great circle is known as the great circle formula. This distance is variously known as the geodesic, great circle or shortest (minor) arc distance. Since the circumference of a circle is equal to $2\pi R$, where R is the radius of the circle, it is immediately evident that the greatest possible distance between the two points is πR .

This distance will occur when the points are opposite ends of a line passing through the centre of the sphere.

Various systems of co-ordinates can be used to denote a point on the earth [Litehiler 1977]. In LSM, the latitude and longitude are used for two case studies and grid reference is for one case study (chapter 9). Point O has the zero latitude and longitude. The geodesic distance between two point i and j, is [Donnay 1945]:

$$a_{ij} = \cos^{-1}[\cos\phi_1 \cos\phi_2 \cos(\theta_1 - \theta_2) + \sin\phi_1 \sin\phi_2] \quad (1)$$

and other methods of designating co-ordinates [Litehiler 1977] lead to various other expressions of this distance.

Change of value of cosine with degrees

Cosine in degrees	Value
0	1.00
30	0.87
60	0.50
90	0.00

Table 7.1

The difficulty is that transportation costs which are available from the company for modelling distribution systems are not on the basis of the arc distance. They are available on the basis of kilometres or miles; the arc distance needs, therefore, to be converted into kilometres or miles. The degree

of latitude is slightly shorter near the equator and slightly longer near the poles (Chapter four).

The length of degree of longitude = cosine of latitude *

length of degree of latitude (chapter four).

Table 7.1 shows the change of the value of cosine. Thus at latitudes 60 degrees north and south, a degree of longitude is half as long as a degree of latitude. The values of longitude are shown in the table 7.2. LSM uses both the great circle formula (for the European and Pakistani studies) and Ordnance survey (for the U.K) distance calculation.

Latitude degree	Kilometres	Status Miles
0	111.321	69.172
10	109.641	68.129
20	104.649	65.026
30	96.448	59.956
40	85.396	53.063
50	71.698	44.552
60	55.802	34.674
70	38.188	23.729
80	19.394	12.051
90	0	0

Table 7.2 Length of One degree of Longitude
(source Robsinon et al 1969)

7.4 Barrier Calculation

To achieve the distance in the model close to the actual distribution distance, natural barriers such rivers and mountains should also be taken into account.

LSM incorporates the barriers and assumes that they cannot be crossed directly. However vehicles can go round the barrier at either side. LSM can handle up to ten barriers in any study. In the first instance, LSM checks whether a particular barrier is situated along the customer to depot path or any other allocation which is under consideration. This is done as follows:

The line between two points BX1, BY1 and BX2, BY2 represents the barrier line. The equation and gradient of a straight line can be calculated by using elementary geometry:

If

$$Y_b = (BY2 - BY1) \tag{2}$$

and

$$X_b = (BX2 - BX1) \tag{3}$$

and if the point of interception of Y-axis is b1, then the line equation is equal to

$$Y_b = m_1 X_b + b_1 \tag{4}$$

where

$$m_1 = \frac{(BY_2 - BY_1)}{(BX_2 - BX_1)} \quad (5)$$

The line between two points CX, CY and DX, DY represents the lines between the customer and the distribution depot. The gradient of this line is equal to m_2

$$m_2 = \frac{(DY - CY)}{(DX - CX)} \quad (6)$$

and

$$Y_c = (DY - CY) \quad (7)$$

and

$$X_c = (DX - CX) \quad (8)$$

therefore the equation of this straight line is equal to

$$Y_c = m_2 X_c + b_2 \quad (9)$$

If there is some point (X_i, Y_i) shared by both lines, then

$$Y_i = m_1 X_i + b_1 \quad (10)$$

and

$$Y_i = m_2 X_i + b_2 \quad (11)$$

will both be true. Therefore if Y_i value is substituted, then equation will be equal to

$$m_1 X_i + b_1 = m_2 X_i + b_2 \quad (12)$$

Solving for X_i yields

$$X_i = \frac{(b_2 - b_1)}{(m_1 - m_2)} \quad (13)$$

Substituting this into the equation for either line 1 or line 2 gives the value of Y_i as equal to

$$Y_i = \frac{(b_2 m_1 - b_1 m_2)}{(m_1 - m_2)} \quad (14)$$

Therefore the point

$$\frac{(b_2 - b_1)}{(m_1 - m_2)}, \frac{(b_2 m_1 - b_1 m_2)}{(m_1 - m_2)} \quad (15)$$

is an intersection point for lines one and two. The next stage is to calculate the distances between the intersecting point and each end of the barrier. The shorter distance from two is then multiplied by the penalty factor being used to adjust the distance. If more than one barrier is involved, the process must be repeated for each.

The two parallel lines will also have the same gradient, so if the lines are parallel then the above equation will be divided by zero.

7.5 Hazard Calculation

LSM defines a hazard as an area which is congested or has a poor road network and therefore takes longer to travel through, such as central London or extremely rural areas. The vehicle is able to pass through the hazard area, but it will take longer. The hazard is represented by a circle. All the allocation lines which pass through the circle are assumed to pass through hazards. There may also be some customers which are situated inside the hazards area. LSM calculates the time taken by adjusting the distance in the following way:

The distance from the centre of the circle representing the hazard to the line between the customer and distribution depot or from the distribution depot to the factory is calculated as follows:

The line between two points is represented by

$$Ax+By+C = 0$$

The centre of the hazard is (x_1, y_1) , so the distance between it and the line is equal to

$$d = \frac{(Ax_1 + By_1 + C)}{\sqrt{A^2 + B^2}} \quad (16)$$

where $d =$ distance.

Since the centre of the hazard is known and the equation of the line is also known, then the above distance can be found very easily.

If $d < r$ (where r is a radius of hazards area) then the delivery line is passing through the hazards area.

To find out where it crosses the hazard area:

A circle with centre (x_1, y_1) and radius r has a equation

$$(x-x_1)^2 + (y-y_1)^2 = r^2 \quad (17)$$

This equation can be expressed in the form of

$$Ax^2 + Ay^2 + Dx + Ey + F = 0 \quad A \neq 0 \quad (18)$$

To find out where the line

$$Ax+By+C = 0$$

crosses the circle, substitute the value of x in the circle equation. The circle equation is a quadratic equation, x is x^2 , it will give two values for the x . Once both values of x have been found, these values can be substituted in a straight line equation to find the values of y at the same points. Once the interception points have been found, the distance between them can be calculated. This distance is then multiplied by the hazard factor.

If the customer and depot are both situated in the hazard area then the total distance between them is multiplied by the hazard factor. If either one of the customer and depot is situated in the hazard area then only the distance of that part of the customer-depot line which passes through the hazard area is multiplied by the hazard factor.

7.6 Allocation

In chapter five, the major state-of-the art distribution software, which is established in the market, has been described. Locate will link each market to the warehouse which can serve it at least outbound transportation cost. The disadvantages in this approach of allocation is that the product is being delivered from the warehouse while it actually comes from production plants (factory). In DSS (Distribution Strategy Simulator), the allocation program allocates the demand points to supply points throughout so as to build up complete paths from source to final delivery on the basis of least total cost, subject to any imposed restrictions on flow within the network.

There are two aspects to be considered in allocation; the first one is which customer is be allocated first and the second is how the allocation is to be done. The above models describe how the allocation is carried out but do not

discuss on the basis on which the first customer to be allocated is selected. LSM starts the allocation with the customer which is farthest from all the depots and transshipment points. It does not require the customers' data to be prepared in distance descending order. It calculates their distances and then sorts them in descending order itself. This procedure for allocation is very useful when capacity constraints are being considered. During distribution modelling in a capacity constrained depot, it was observed that sometimes a customer was allocated to a farther depot because the nearest depot had no stock to satisfy the demand.

The allocation of a customer to a depot is done by the same procedure as is used by DSS. LSM builds a network between customer to depot to factory and includes the distribution depot handling cost. When it considers the allocation of customer to transshipment point, it builds a link and cost network between customer to transshipment point, from transshipment point to distribution depot and from distribution depot to factory. It also includes the handling costs at the distribution depot and transshipment point. The handling cost is included to take account of handling technology being used at the depots and transshipment points.

The transshipment points are allocated to the cheapest depot by building a cost network from factory to the depot and to the transshipment point, plus handling cost at the depot. It also takes into consideration throughput constraints on the depot, and production capacity constraints on the source point or factory. Distribution depots are allocated to the cheapest source point or factory.

All the customers, transshipment points and distribution depots are allocated on the basis of total enumeration. The total enumeration is to calculate the cost between all possible links which can be built in the system for allocation and take the least cost link from these and allocate the allocating facility to it. In other word the allocation is performed on an optimum basis. There are

two reasons for using this procedure in LSM: (a) to enable the customer to be served at the least possible cost, and (b) to enable the capacity constraints on depots, transshipment points and factories in a distribution network to be taken into account.

Each customer can receive goods from only one source, and each transshipment point also receives its total throughput from a single distribution depot. However each distribution depot is able to receive goods from more than one source and can deliver to more than one transshipment point and customer.

7.7 Local Delivery Cost

The local delivery cost, also known as an outbound transportation cost, is the largest single cost in a distribution system [Christofides 1981]. Therefore it is very important that it is accurately represented. The other important phenomenon which applies to strategic planning particularly, is that all the costs are represented in a right balance. If one cost is represented in much more detail than the other, it will shift the balance of decision significantly into its favour. The resulting facility location and serving areas may not be the least cost solution.

The cost of making delivery to a user from a given facility is approximated by a linear function of the radial distance between the user and the facility. Webb pointed out that such an approach is inadequate [Webb 1968]. A small increase to an existing delivery or collection quantity may add an insignificant and undetectable amount to the actual transport cost if the vehicle has spare capacity, but might add the cost of a special journey if there is no spare capacity. Similarly, an extra delivery or collection may cost virtually nothing if a vehicle with adequate spare capacity is already due to pass that way.

There are three approaches which are commonly used for the calculation of

local delivery cost:

a) The most popular approach is to assume that vehicles visit customers on a there and back basis. This is perfectly valid if the number of customers per trip are small eg 2 or 3.

b) A more accurate but cumbersome approach is to use a vehicle scheduling package in a simulation mode. That is to say, the routes which would have been run if possible alternative sites were actually being used can be compared using historical customer order data. The routes may then be costed very precisely. This approach does require the collection of considerable amounts of data which takes a great deal of time.

c) The final approach is to use a mathematical formulae, which relates distance between customer and depot to the route distance. Such formula was proposed by Eilon et al [Eilon et al, 1971].

The first approach is quite useful for a car or oil company. In the car industry, usually only one car is being delivered to a customer and there and back distance is sufficient for local delivery cost. In oil industry, where one company might have two or three gas stations in a town which are served by one vehicle; again, there and back distance will be sufficient for local delivery cost calculation.

The second approach seems quite realistic because it will produce a distance close to actual distribution distance. However for strategic planning decisions, it is often sufficient to obtain approximate estimates of costs and distance that require much less detailed data and do not depend on complex numerical computations.

The third approach seems more realistic for distance and cost calculation. Simple analytical techniques have been developed that provide such estimates

based on global characteristics of the distribution network [Beardwood et al 1959, Eilon et al 1971, Stein 1978 and Daganzo 1984, 1984a].

This technique is a variant of the classical "cluster first, route second" approach to vehicle routing problems. Eilon et al derived a formula in which gives the distance L , needed to visit N points uniformly scattered in a square zone with a centrally located depot, where routes are built with the best computer algorithm available [Eilon et al 1971]. Daganzo [Daganzo 1984b] use the Eilon et al formulae and show that distance travelled per point is equal to

$$L \approx 1.8 \alpha \left[\frac{1}{C} + \frac{1}{\sqrt{N}} \right] \quad (19)$$

where α represents the average of the distance from the depot to a random point in the square. C is the total number of stops each vehicle makes per journey and N is the total number of customers served by the depot. If the area of the region is known and is equal to A , then distance α can be expressed by equation (11);

$$\alpha = \left(\frac{A}{6} \right)^{\frac{1}{2}} \left(\sqrt{2} + \log \tan \left(\frac{3\pi}{8} \right) \right) \approx 0.382 A^{\frac{1}{2}} \quad (20)$$

If the area is not known then α is equal to radial distance. The term $1.8\alpha/C$, is often interpreted as the "line haul" distance portion of the distance needed to reach the general location of each point, which is of course shared by C stops. The second term is $1.8 (\alpha/\sqrt{N})$, can be interpreted as the amount of "detour" distance needed to actually deliver each item, since the term is proportional to (though some what smaller than) the distance between nearest neighbours. Similar equations seemed to work fairly well for other

depot locations within the square. Daganzo [Daganzo 1984a] developed a length formula, similar to Eilon et al [Eilon et al 1971], which will be applied if $C > 6$ and $N > 4 C^2$, then equation (10) is equal to

If $C > 6$ and $N > 4 C^2$, then

$$L \approx \frac{2\alpha}{C} + \frac{0.57}{\alpha} \quad (21)$$

and for a square zone equation (12) can be rewritten as follows:

$$L \approx 1.8\alpha \left[\frac{1.1}{C} + \frac{0.83}{\sqrt{N}} \right] \quad (13)$$

It is similar to equation (10) but it yields results only slightly larger for large values of N and C . Daganzo performed several experiments to test the accuracy of the formula and found that in all cases agreement was good [Daganzo 1984a].

Burns et al [Burns et al 1985] used the result of Daganzo's study [Daganzo 1984a] to derive the following formula for the local delivery cost. They also divided their local delivery distance into two categories: i) The local delivery distance from depot to customer zone, and ii) The distance in the zone, which is known as a "detour" distance (d).

$$d = K \sqrt{\frac{mn}{p}} \quad (23)$$

where

d = detour distance;

- n = number of customers per delivery region (ie delivery region size);
 p = customer density (customer per square kilometre);
 K = constant.

Blumenfeld et al derived a formula which can be used to estimate the number of stops per load [Blumenfeld et al 1988].

$$m = \frac{NV}{N+J} \quad (24)$$

Where

- N = total number of customers;
 J = Total number of items per dispatch;
 V = Item per load.

Burns et al [Burns et al 1985] used Daganzo [Daganzo 1984a] method to calculate the local delivery cost.

$$F = \Gamma + \alpha D + K \sqrt{\frac{mn}{p}} + \sigma m \quad (25)$$

- Γ = fixed cost for initiating the dispatch;
 α = transportation cost per unit per distance;
 σ = fixed cost of customer stop;
 D = distance from depot to customer zone;
 F = local delivery cost;

Blumenfeld et al [Blumenfeld et al 1988] use the value of $K \approx 0.6$ when m is greater than two or three. However, in another study Daganzo used the value of $K \approx 0.5$, and suggested that $0.6 \geq K \geq 0.5$ [Daganzo 1987].

Burns et al's algorithm [Burns et al 1985] does not take into account vehicle capacity and the number of hours a driver is allowed to work (time factor). Both these factors are important to local delivery and they do have an effect on the local delivery cost, especially when a hub depot is considered on a UK or, even more importantly, European basis.

It is not apparent how the state-of-the-art software described in chapter five calculates the local delivery cost. It is nearly impossible to compare the LSM cost with other state-of-the-art distribution software. LSM does, however, improve the Eilon et al algorithm [Eilon et al 1971] by including the time factor for local delivery.

The total distance = Local delivery wiggle factor
 1.8 Straight line distance
 *[(total demand of customer/Vehicle capacity)
 +1/ Sqrt(total number of customer served by depot)]

To calculate the total time, stem distance is divided by stem speed and zone distance is divided by the zone speed. The customer's unloading time is added to the total time. If the total time is greater than the number of hours allowed for driver to work, an extra day's cost is added to the local delivery. Therefore the total cost to deliver to a customer is equal to following equation:

$$\text{Cost} = (\text{rate per kilometre} * \text{total distance in kilometre}) + \text{extra days cost.}$$

This cost is linear with the distance; at strategic level this assumption is valid. This algorithm gives results very close to actual practical value for our validation stages.

7.8 Trunking Cost

The trunking cost is a transportation cost between factory to depot, and from

depot to transshipment point. Eilon et al considered three different type of cost for trunking delivery [Eilon et al 1971]:

(i) The trunking cost from the factory to depot i is β_i per unit amount and distance. As supply to the depot is often carried out in bulk.

$$H = \beta_i W_i d_{oi} \quad (26)$$

where

- H = Trunking cost;
- β_i = is cost per unit amount distance;
- W_i = amount transported to depot i ;
- d_{oi} = distance from factory to depot i ;

In this particular case the cost is increased linearly with either the distance or weight.

(ii) In the second model trunking cost parameter β_i is replaced by a new parameter Γ_k which is not related to distance. The region is divided into r districts, each district having its own parameter Γ_k . The trunking cost from factory to depot is then expressed as

$$H = \Gamma_k W_i \sigma_{ik} \quad (27)$$

where

- Γ_k = cost per unit weight (or amount) delivered when the destination is in district k ;
- W_i = weight (or amount) delivered to depot i ;
- σ_{ik} = $\{1,0\}$.

(iii) In the third case, the trunking costs are found to be linearly related to distance, but parameter β is dependent on the district in which the depot is situated. Thus the region under consideration is divided into r districts and the rate β_k is quoted for bulk transportation to depots in district k (where $k = 1, 2, \dots, r$).

The parameter of β_k changes when depots cross district boundaries. The trunking cost from factory to depot i is then expressed as

$$H = \beta_k W_i D_{oi} \sigma_{ik} \quad (28)$$

Where

β_k = cost per unit amount and unit distance when the destination is in district k and

$$\sigma_{ik} = (1, 0)$$

Burns et al also consider the trunking cost algorithm for minimisation of transportation and inventory cost for General motors [Burns et al 1985].

$$H = \Gamma + \beta + \alpha D \quad (29)$$

Γ = fixed cost of initiating a dispatch (\$/load);

β = fixed cost of a customer stop (\$/stop);

α = transportation cost per unit distance (\$/km);

D = distance travelled;

H = trunking cost;

Again no information is available on in the state of the art software (chapter

five). The factors that are important in trunking cost are a) trunking vehicle capacity, and b) driving hours allowed.

Burns et al's algorithm does not consider the trunking vehicle capacity and the driving hours allowed, ie the extra days cost [Burns et al 1985]. The driving hours are important for true cost representation because drivers are allowed to drive only a limited number of hours per day. These costs become quite significant if a model at a European scale is considered. LSM uses the following algorithm:

$$\text{Distance} = (2 * \text{Straight line distance}) * \text{Wiggle factor} ;$$

$$\text{Trunking time} = (\text{trunking distance (there and back)} / \text{trunking speed});$$

If the trunking time is greater than trunking trip time then the extra days' cost and extra trip hours are added until trunking time is less than trip hours.

It may be possible that full volume of the vehicle is not fully utilised; in that case the percentage of utility may also be taken into account. In this case the trunking capacity is taken as trunking utility percentages.

In some cases the depot is situated at the factory so there is no cost related with distance for trunking, but there is a cost for moving product from factory to depot.

The number of vehicles used =

$$\text{int} \left(\frac{\text{Total demand in a define period}}{\text{Trunking vehicle capacity}} + 0.9999 \right)$$

ie. the minimum vehicle used is one.

Trunking cost in defined period = Trunking Vehicle capacity
 * Number of vehicle
 * (cost per unit volume
 + cost per unit per distance
 * total distance {there and back})
 + extra days cost if any

The local delivery cost and trunking cost are linear with distance. This was true for the case studies carried out for model validation. In most cases the above approach is valid for strategic study.

Also important is which sort of information is available from the company. The best algorithm is the one which gives results close to practical value and it derives those results by using the cost functions which are readily available from the company and the above algorithms accomplish these objective.

7.9 Warehouse cost

The total warehouse cost is a combination of a fixed cost and a variable cost. The fixed cost includes:

lands (rent charges);
 buildings (rent and rate charges);
 services such as gas, electricity and telephone;
 equipment charges and some of staff wages.

Variable costs which depends on the throughput includes:

labour (for example pickers, packers);
 supervision (for example depot manager);
 and any other cost which depends on the throughput.

LSM is able to take into account a different fixed cost for each warehouse. The fixed cost depends on the lands and building, the prices of the land and buildings are far from uniform. It also has a variable handling cost for each warehouse. This enables LSM to take into account which the warehouses use high technology equipment for handling throughput and storage. Both these facilities will help LSM to model a real world logistics system and realistically represent the warehouse costs.

7.10 Inventory cost:

Inventory cost is an essential element in the strategic planning of a logistics system [Bowersox 1978, Heskett et al 1973 and Shycon 1960]. Therefore it is vital that inventory carrying costs are accurately described since they are major factors in determining the number of facilities in a network. However, inventory carrying cost is difficult to estimate precisely. In addition to the opportunity cost of capital, carrying cost depends on the insurance, handling, storage, and obsolescence costs of holding inventory [Blumenfeld 1987].

Baumol's warehouse location model was the first to include the inventory level-to-demand relationship [Baumol 1958], but has not generally included since then [Ballou 1984]. Possibly their omission from most warehouse location models has been to avoid the mathematical complexities that they cause [Ballou 1984]. The Distribution Strategy Simulator (DSS) (chapter five) was developed without inventory cost consideration. Inventory cost was added to it only after its completion.

In a logistics system stocks are divided into three categories on the basis of their physical form:

- i) raw materials and fuels, awaiting input into production process.
- ii) Work in progress ('in-process inventory') undergoing processing or in a semi-finished state awaiting further processing.
- iii) Finished goods, ready for distribution to final customers. LSM is only focusing on the distribution of finished goods, many of the inventory

management principles that will be advanced here are equally applicable to the storage of raw materials and semi finished product at early stages in the logistical channel.

7.10.1 Stock replenishment

Stock replenishment policy must provide answers to two fundamental questions:

- i) When should stocks be replenished?
- ii) How much should be reordered?

There are two type of stock held at distribution depot:

- a) Cycle (or working) stock; and
- b) safety (or buffer stock).

Cycle stock is that which is required to satisfy the average level of demand during the period between the placing of an order and the arrival of the goods at the depot (ie order lead time). Goods arrive infrequently in bulk loads, but flow out more gradually in small consignments. This causes the level of stock in the depot to fluctuate. When expressed graphically, these fluctuations exhibit a "saw tooth". If the supply and demands are constant then only cycle stock is sufficient. If the demand is not constant then cycle stock may be supplemented with safety stock to cater for uneven demand. The addition of safety stock effectively displaces the "saw tooth" profile upwards, reducing the number of occasions when it dips below the horizontal 'zero stock'.

Two general systems of stock replenishment are widely applied in industry:

- i) Continuous review system: stock levels are continuously monitored and when they fell below a specified reorder level, an order is placed for a fixed quantity of replenishment stock. The period between orders is variable whereas the amount order each time remains fixed. This is also known as the fixed order quantity or the fixed order point system.

ii) Periodic review system: orders are placed at a fixed intervals, regardless of the amount of stock on hand, and are of the amount required to bring stocks up to some predetermined level. In this case, the time interval between orders is fixed, where as the order quantity can vary. This is sometimes called the fixed interval system.

LSM uses a continuous review system which is generally more efficient. Simpkin et al found that it was employed by 56 percent of a sample of 2000 large British retailers [Simpkin et al 1987].

LSM uses a simple method for estimating overall inventory levels for planning purposes. The item-by-item estimating procedure is impractical when there are hundreds of stock keeping items held at many distribution depots. LSM uses a regular stock, which is the amount of inventory to meet average demand over the period of time from one stock replenishment to the next. Based on the Wilson Economic Order Quantity formulation, regular stock in a warehouse for the j th item is, on average

$$(RS)_j = \sqrt{\frac{d_j S}{2KC_j}} \quad (30)$$

Where

$(RS)_j$ = Average regular Stock for item j units;

d_j = Annual demand for item j units/year;

S = Procurement cost;

K = Inventory carrying cost % of item value per year;

C_j = Item value for item j , \$/unit.

Assuming all items in the warehouse have the same K and S , and C represents the average value the product class, then total regular stock for n items in a warehouse is:

$$\sum_{j=1}^n (RS)_j = \left[\sqrt{\frac{S}{2KC}} \right] \sum_{j=1}^n \sqrt{d_j} \quad (31)$$

If D_j is the total demand (throughput) on warehouse i and if there is not a great deal of difference in the levels of d_j then

$$\sum_{j=1}^n (RS)_j = \left[\sqrt{\frac{S}{2KC}} \right] \sum_{j=1}^n \frac{\sqrt{D_j}}{n} \quad (32)$$

which is equal to

$$= \sqrt{\frac{Sn}{2KC}} \sqrt{D_j} \quad (33)$$

and is a reasonable approximation to equation (23). If all warehouses contain roughly the same number of items for a particular class, then total regular stock in a warehouse can be approximated as

$$I = a\sqrt{D_j} \quad (34)$$

Therefore, for N warehouses

$$I_T = a \sum_{j=1}^N \sqrt{D_j} \quad (35)$$

when there is equal demand on each warehouse and all other factors remain

constant.

$$I_T = \sum_{j=1}^N (w + mD_j + aD_j^b) \quad (36)$$

where

I_T = System-wide inventory, in units or \$;

D_j = Annual warehouse throughput, in units or \$;

N = Number of distribution depots at which the products are held;

w, m, a, b = Constants to be determined from company data usually by curve fitting procedures.

The terms in the equation have the following general meaning:

w = The average amount of promotional, speculative, obsolete, or production overrun stock at a distribution depot;

mD_j = The amount of safety stock at distribution depot j ;

aD_j^b = The amount of regular stock at distribution depot j ;

Theoretically, when inventory control is based on statistical inventory theory, the total inventory throughout a system of multiple warehouses can be determined from the following expression:

$$I_T = \sum_{j=1}^N \sqrt{\frac{D_j S}{2KC}} (\text{Regular Stock}) + \sum_{j=1}^N Z S_d \sqrt{\frac{N_o LT}{N}}$$

where

D_j = Period demand throughput at warehouse j ;

S_d = Standard deviation of demand;

- K** = Carrying cost in percent ;
C = Average product value;
S = Order processing cost;
Z = Number of standard deviations for a given service level;
N₀ = Initial number of distribution depots;
N = Revised number of warehouse;
LT = Average replenishment lead time;
L_T = Total System Inventory.

The first part of equation (37) is equal to regular stock and second part is equal to safety stock. Therefore the equation (37) is reduced to equation (38) when there is a equal demand on each warehouse and all other factor remain constant.

$$L_T = a \sum_{j=1}^N \sqrt{D_j} \quad (38)$$

LSM uses this equation to calculate the inventory holding cost for each product at each depot.

7.11 Depot delivery area:

Buxton et al derived two formula to define the boundaries for distribution depot [Buxton et al 1971]. The first formula finds the maximum distance a depot can serve. The formula is as follows:

$$D = \frac{ab}{2c} \quad (39)$$

Where

- D** = the required one way distance in miles to the time constraint boundary ;

- a = available number of driving hours per day;
- b = the average mile per hours per zone - three zone were define, rural, rural/urban and urban;
- c = the ratio between the furthest peripheral point in miles and total journey miles.

Buxton et al plotted these values on a zonal map around the depot location, and found route based time-constraint boundary.

The second formula finds the iso-cost boundary for a depot;

$$VDC_x = \frac{v(r_x - r) + V_j}{j^- + j^- \left(\frac{t_x}{t} * \frac{(r_x - r^-)}{r^-} \right)} \quad (40)$$

Where

- VDC_x = variable distribution costs per ton for route through selected point x;
- v = variable cost per mile;
- r_x = route mileage where selected point x is the furthest peripheral point on the route;
- r- = current average route mileage;
- V = variable costs per ton;
- j- = current average route mileage;
- t_x = market demand in tons per square mile in the grid square within which selected point x is situate;
- t = market demand in tons per square mile in the existing area serviced by the private vehicle fleet from depot.

The main disadvantage of using the above techniques is that they produce sub-optimal solutions. The product source is not a warehouse but a production

plant. SITE (chapter five) also claims that it has the facilities for boundary planning. However it does not give any information of the method or procedure is being employed to calculate the boundary area of a depot.

LSM defines the warehouse service area by allocation through the network by using the previously described allocation theory. The customers are allocated to the cheapest depot taking in consideration total network cost from production to customer. Once the allocated customers are known, then it uses the cross product formula to draw the boundary for a distribution depot. The cross product formula is

$$v \times w = [(v_2 w_3 - v_3 w_2)(v_3 w_1 - v_1 w_3)(v_1 w_2 - v_2 w_1)] \quad (38)$$

In the two dimensional plan on which LSM operates, the first two values of above equation are equal to zero, so only last value is considered.

For each depot LSM finds the furthest customer. This customer becomes a centre for drawing the boundary for that depot. The line of boundary will start from this point, called O, and will end on it. From this point, model finds any other customer which is being served by the same depot and the line between two point is a vector v. The model then looks for another customer and line between O and this point is vector w.

If the cross product between two vectors is positive vector v remains the same but the model looks for new vector w. If the cross product is negative then vector w becomes vector v and the model looks for new vector w. However if it cannot find the negative product then it draws in a line between the two points of vector v. The new point becomes the centre and above procedure is repeated from this point. The model carries on until returns to first point where it began. If there is only one customer is being served by the depot then model will draw the line between the depot and this customer.

This formula works very well when there is only one product and one manufacturing plant and more than one warehouse in a logistics system. No overlapping of boundaries occurs (see validation of model). Most of the time when model was used with more than one product and many factories, it provided separated boundaries but sometimes the boundaries did overlap (see validation of model). The overlapping occurs because customers are not allocated to nearest depot but to the cheapest depot through the network and there is more than one product in the system.

7.12 Forecasting

Although the name forecasting is given to this function of LSM, it is a more like a "what if" facility. This is an important integral part of the software. For strategic study such questions as what happens if product A sales go up 10 percent or if product B sales decrease 5 percent in a particular area help to shape the structure of the distribution network. LSM can handle the forecast in three different ways:

- (i) Same percentage increase or decrease for all the customers in the system. This is achieved by multiplying the demand of customer with the percentage factor. If the demand is going to increase 10 percent then the demand of the each customer is multiplied by 1.10. However if the demand is decreased by 10 percent then demand of each customer is multiplied by 0.90. The programme checks that the warehouse has the throughput capacity and the plant has the production capacity to meet the new demands.
- ii) The customers demand can be increased or decreased by product numbers. In this case each product can be assigned a different forecasting factor. The program displays the product number, one at time and by using the above procedure, demand can be increase or decrease for each product.
- iii) The third procedure is probably unique to visually interactive modelling. In this case, demand for the customers can be increased or decreased on an

area basis. The area is selected by using LSM window function. The window size and place on the screen is defined by the user and it is very user-friendly. The size of the area could be as small as one town and as large as the full map. All the selected areas can be assigned a different forecasting factor.

7.13 Search for best Location:

To find an optimum location for the depots, which in return provides the optimum solution for the logistics system (under the constraints and conditions) has always been the dream for an operational research scientist. If a logistics system has only one distribution depot which serves all the customers in the system, there are more than one optimum solutions and optimising method will find one of these solutions. If there is more than one depot in logistics system, there is no optimum solution which can be derive in reasonable computer running time by using a reasonable detail cost data.

Heuristics in combination with computer graphics is probably the best answer available to the multi-depot location problem. The user is able to observe all the information on the screen and then make his or her decision accordingly. The computer will provide the decision consequences in term of cost in figures and other details graphically on the screen.

The following search procedure was first proposed by Lawrence et al [Lawrence et al 1969]. They placed a rectangular box on the depot so that depot is in the middle of the box. They calculated the cost of locating the depot at the centre of a box and then move the depot to each corner of the box and calculated the cost at each point. They compared all the costs and made the least cost point the centre of the box and the location of the depot. They repeated the process until centre of the box was also the least cost point. They then reduced the size of the box and repeated the process again until the box size reached the minimum possible and decided this is the best location for the depot.

LSM employs the diamond shape to search for the best possible location for the depot. The minimum step for movement of a depot in LSM is one pixel. Even when one is working in world coordinate (chapter four), the image on the screen is still being drawn by using pixels. For experimental reasons, the program was tested by making the local delivery cost equal to zero. LSM moved the depot near to factory but not on the factory. The step was reduced to minimum and after a long search the depots were placed on the factory's location and all the transportation cost were equal to zero.

In a one depot system or in a system where customers are being forced in allocation, the maximum and minimum allocation steps required to find the least cost solution are two (allocation steps are different then the movement of the depot step). In this case the model starts moving the depot and continues until it has found the least cost solution. Then it comes out of search procedure and start allocating customers to the depot and calculating the total system cost. It goes back into search procedure and searches for the least cost solution again. In a one depot problem, the least cost location will be the same as in the previous solution. It will come out of search procedure and will calculate the total system cost again and compare them together. If they are both equal then this is the least cost solution.

In a case where the logistics system has more than one depot and customers are allocated to depots on optimal basis, LSM will find the least cost location on total system basis. It will move all the depots in their serving area as described in a one depot search procedure. It will come out of the search procedure and reallocate the customers to the cheapest depot, taking into consideration whole distribution network cost. This allocation may well be different from the previous one, because depots have been moved from their original position. LSM moves each depot again in the market area and find the least cost location. It allocates the customers again by the same procedure and compares the two system costs. If the two consecutive system costs are equal than this will be the least cost solution. If they are not equal then it

will carry on until it found that moving the depot will not reduce the total cost of the system. This is the least cost solution under the given circumstances.

LSM may also be used to move some part of the distribution system rather than whole system. The user can highlight depots on the screen and the model will not move the highlighted depots. This function is useful for practical purposes where a company wishes to look at part of their distribution network rather than their whole network.

The above algorithm does not guarantee the optimal solution. The final solution depends on the initial location of the depot. It is also biased towards the greater demand customers. However, used in combination with computer graphics it provides the best possible solution under the circumstances.

7.14 Modification

LSM is a decision support software. It does not make any decision but it provides the information in the best possible format to help the decision maker to make the decision. Modification is a LSM facility, where decision maker implements his or her decision.

In modification mode, all the characters are displayed in a graphics mode on the screen. Halo does not have the character window support system. Therefore it will not be able to read characters from the keyboard. However for LSM purposes, where most of the information is entered on the keyboard, the character window facility is very important. To overcome this problem a subroutine was written in assembly language. This subroutine will support any hardware system which has intel 8088 chips. All the new Intel processors, such as 286, 386 and 486 will support the 8088. Therefore this routine will be able to work on many different machines. This subroutine will read the characters from the keyboard and pass them into Halo graphics mode, so they can be displayed on the screen.

For modification, Halo's crosshair cursor facility is used. The crosshair cursor looks like a (+) sign and its height and width are user-defined. It is displayed in white colour but it can be displayed in different colours. The crosshair cursor can be move over the screen on an existing map and other displayed data non-destructively. In other words, when the cursor is placed over an image, the image is not altered in any way (assuming no other command is issued that may alter the image). The centre point of plus sign is consider as a target point.

The user is able to add, move and delete the depots, factories and customers on the screen visually. All the cost functions can be modified by visual interactive means. In case of depots, the user can see on the screen their throughput and maximum capacity. In case of customers the user is able to move the window in a particular area and is able to observe the details of all the customers in a window area.

However for moving and deleting, it is sometimes difficult to pinpoint the right target. The movement of the cursor depends on the length of jump from one step to next. If the jump is minimal ie one pixel, it will take a long time to move the cursor. If the jump is larger the user will not be able to target the right object. LSM uses the arrow key for larger jumps and when the cursor is near to object, one pixel step to select the target.

7.15 Zooming

Logistics strategy models allow the user to zoom in to any part of the screen. On zooming all the information is displayed in much more detail. The zooming area is selected by using the LSM window facility. This window was developed by using the rubber bands. Like the crosshair cursor, it is non-destructive and can be moved to any part by using the arrow keys. It size can be increased by using the (+) sign or decreased by using (-) sign. It works only in the screen coordinate (chapter four). When a particular area is selected on the screen for zooming, the screen coordinates are converted to

world coordinates by using the Halo graphics conversion function.

One method that may be used for displaying the zoom information on the screen is by decreasing the size of the world coordinates. In this particular case, zooming will produce a distorted image on the screen.

LSM uses a combination of clipping and transformation (chapter four) to do zooming. In this case world coordinates are the same but new value X and Y coordinate is calculated to display them on the screen. The values of WX and WY which as original values for the map and new value to be display on the screen are VX and VY are calculated by the following equation.

$$VX = \frac{VX_{max} - VX_{min}}{WX_{max} - WX_{min}} (WX - WX_{min}) + VX_{min} \quad (42)$$

$$VY = \frac{VY_{max} - VY_{min}}{WY_{max} - WY_{min}} (WY - WY_{min}) + VY_{min} \quad (43)$$

Where

WX_{min} = minimum value for x for window;

WX_{max} = maximum value for x for window;

WY_{min} = minimum value for y for window;

WY_{max} = maximum value for y for window;

VX_{min} = minimum value for x for viewport;

VX_{max} = maximum value for x for viewport;

VY_{min} = minimum value for y for viewport;

VY_{max} = maximum value for y for viewport;

VX and VY are new value of WX and WY.

This formula is used to calculate the new map coordinates to be displayed on the screen. It also calculates the new location places on the screen for factories, depots and customers. The shape of the object on the screen is increased by the ratio difference in old and new world coordinates.

7.16 Conclusion

In this chapter, technicalities of the sub-routines, which on amalgamation generate LSM, are described. The adopted approach is discussed and the reasons for its adoption are given. Detailed analysis is provided for each function of LSM. The flow charts and further analysis will be provided in next chapter.

Chapter Eight

Model Structure

8.0 Introduction

In chapter seven, the reason for adopting a particular approach in LSM development was given. In this chapter comprehensive details of that approach will be given. The data flow diagram for each subroutine will be depicted and its contribution to LSM functions will be discussed. The data requirements for the model and a particular format in which a database file can be designed to use in LSM will be provided. The overall working logic for the model will be discussed.

8.1 Model Overview

For a distribution model to solve a problem, it needs data to be provided in a special format and order. LSM reads the data in MS-DOS format. The database file can be prepared by using a word processing package, or any other software which is able to save data under DOS format. LSM also has its own data preparing facility which can be used to prepare database files. However, it first needs the data to run the model and then it can be used to prepared new files.

To run, LSM requires a map file, which contain the X and Y coordinate in a acceptable units; a factory file which has the information for location of plants, or source points, and their production capacity; a depot file containing location and throughput information; a customer file, which has the demand and location information; and a cost file, which has various costs that are required for the model. Hazard and barrier files are optional. The hazard file contains details of congested areas in the appropriate geographical region. The barrier file can include the information concerning natural barriers such as rivers and mountains etc.

LSM stores all the input data in RAM (read only memory) or Arrays (another

name for RAM). It calculates each customer distance from every depot/transshipment point in the system. It adds the calculated distance and then sorts the customers into distance descending order. This is employed for customer allocation because LSM allocates the furthest customer from all the depots and transshipment points first in the system.

LSM assumes that all the customers' demands will be satisfied by production and depots throughput capacity. It adds the demand for each product and adds all the production for same product and compares the two. If demand for any product is greater than production for same product, the program will terminate. It also adds the total demand by the customers and total depot/transshipment throughput capacity and if throughput capacity is less than demand, LSM will terminate.

LSM has two type of allocation procedure. The first one is to replicate the existing situation (if there is one) and is used for validation of the model. In this case, the modeller will decide before running the model which customer is allocated to which depot and which depot is allocated to which production plant.

The second allocation is based on operational research optimisation techniques. In this case LSM will allocate the customer to the cheapest depot/transshipment point, building a path network from production plants to customer. This network will take into account such constraints as the production capacity of the plant and throughput capacity of the depot/transshipment point. This optimum allocation is based on total enumeration because it considers the limited number of distribution depot/transshipment points in a system. The main objective is that the model allocates a customer by cheapest possible means under the circumstances.

For each customer it builds a path network as follows:

customer -> depots -> factory

or

customer -> transshipment point -> depot -> factory.

If first path is used for allocation, LSM will calculate the cost of serving a customer from depots and handling cost at the depot (to take into consideration depot handling technology). It will also calculate the cheapest cost between depot and production plant. If the product is being produced at more than one plant then it will calculate the cost between this depot and all the production plants and will take the cheapest among them.

If the second network path is being built then LSM will calculate the cost from customer to transshipment point and the handling cost at transshipment. It will calculate the cost between transshipment and all the depots in the system and between each depot and all the production plant which produce the same products. It also includes the handling cost at each depot. Once the cheapest depot has been found, it will calculate the cost between the depots and the factory. It will add all these cost together to form a network path cost.

Each customer will have same number of allocation network paths as the total number of depots and transshipment points in the system. At the end LSM will allocate the customer to the least costly network of depot/transshipment point.

LSM also builds similar network for transshipment point allocation to depots and depot allocation to factories.

LSM is unique among existing models in its search for the best possible location for a depot in a serving area. It employs a visual interactive technique for the movement of the depot. The manager is able to observe on the screen what is happening in the black box. The technical details of this

procedure have been explained in chapter seven. LSM has three different size of diamond shape boxes which are placed on top of depot serving area so that the depot is placed in the middle diamond shape. The first box shape is the largest and the third box shape is the smallest. LSM will change the shape of the box whose central location has the least cost solution. On using the third box when central location has the least cost solution, it will leave the depot at this position. It will continue the above search for all the depots in the system until cost cannot be reduced any further.

Modification is also performed by using the computer graphics. LSM was developed on computer graphics. Modifications such as deletions are carried out by pointing the cursor to the object to be deleted such as factory depot or customer. The adding position of a facility such as depot is found by moving the cursor to adding position. This is also unique to LSM; other models which are building interfaces to their existing models show only output in graphics format.

The user-friendly modification is fundamental for the models which are developed for distribution strategy design. Most distribution strategies are based on "what if" analysis. If the distribution software is rigid or difficult to use it will not encourage the modeller to utilise all its functions and test all possible options for designing a distribution network.

To test "what if" on allocation, LSM provides a manual allocation function. By using this function the user is able to allocate any customer to any depot/transshipment point and any transshipment point to any depot and any depot to any factory all by visual interactive means. LSM will draw the lines between two facilities and will display the related cost on the screen.

LSM provides comprehensive details in its output report. The report can be directed to a printer or it can be displayed on the computer screen. Both facilities are useful; the screen output report can be is used to make such

decision as where to locate a depot or move a depot or delete a depot. The hard copy report is used to present the results and information to the company and for recording purposes.

The output report provides the following information:

For each customer it gives details of its location, the distance between it and the serving depot/transshipment point, and the serving cost.

For each depot the output report provides its name, location, total throughput capacity and actual throughput for each product, total handling cost, fixed cost, total inventory cost and total cost for each depot/transshipment point.

For each factory it provides its name, location, production capacity and the product being produced.

For allocation output report gives following information:

For each factory it gives the names for all those depots that are being served by it and amounts of product is being delivered to them.

For each depot it gives the name of those transshipment points that are being served by it and demand for each transshipment point met by the depot.

LSM output reports also provides the information for total distance travelled for local delivery and trunking delivery, total local delivery cost, trunking cost, local trunking cost, inventory cost and system cost.

To be able to see all the object on the screen much more clearly, LSM has zoom-in function. This function is used to display the map and other objects on the screen in great detail.

LSM also provides screen print facilities, some of which are given in validation of the model. The printing of screen in graphics mode is different then printing it in a character mode. At present Amstrad printer is used but other printers can be used to print the screen.

The data flow diagram of model structure is shown in figure 8.1.

8.2 Data base file structure

8.2.1 Map data base file

LSM uses a map file to display the map of the country or region which is being considered for logistic strategy modelling. The data for the map coordinates could either be in degrees or kilometres. The two units are employed because the map data for world map is mostly available in degrees and data for United Kingdom is available in kilometres. An important factor to be bear in mind is that the location of all facilities must be given in the same units as the map.

8.2.1.1 Elements of map file

The elements of the map files are depicted in figure 8.2. The map file contains a password, MAPFIL. Each LSM file has its own unique password, which checks that the right file is being used at the right place. LSM displays the map in two dimensions; therefore, this file contains two coordinates values, x-coordinate and y-coordinate values. The left hand side value of figure 8.2 is a x-coordinate value and right hand side is y-coordinate value.

When the latitude and longitudes are used the left hand side value is longitude and right hand side value are latitude.

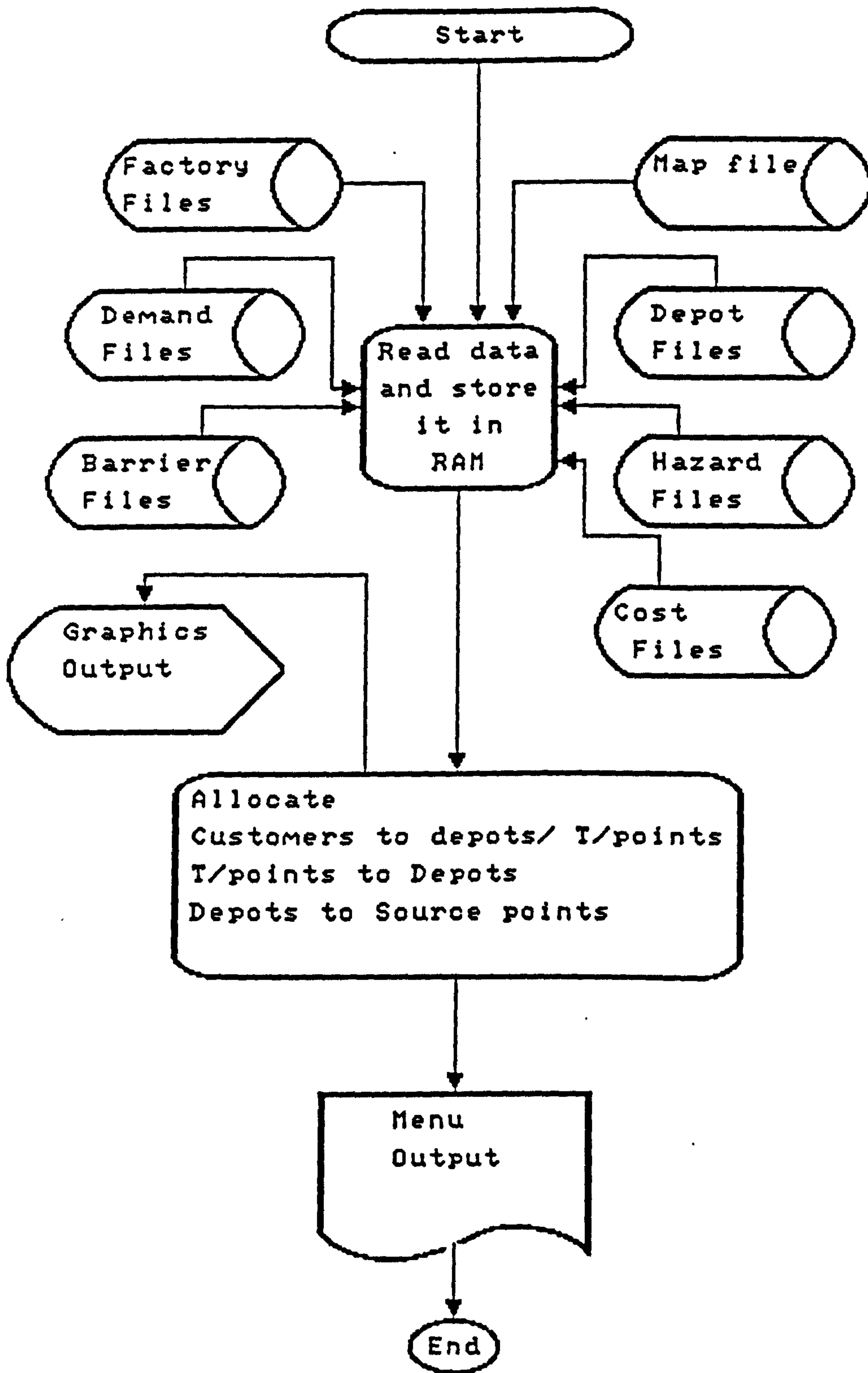

Figure 8.1 LSM Structure

MAPFIL	
140	30
140	20
140	30
140	20
150	30
160	30
170	15
175	19
180	20
180	30
190	30
190	40
200	40
200	50

Figure 8.2 Map database file

8.2.2 Factory database file

The factory file contains names, locations, maximum production capacity and product identification number. LSM is able to model up to ten products concurrently. This file also contains the inventory cost for this product in a modelling period ie, the cost of holding a unit of this product at any depot in for modelling period. If the data is being modelled on a weekly basis and product unit is used for modelling is in kilograms then the inventory cost will that of holding a one kilogram unit of at any depot for one week.

DPLANT
1
1,372.0,310.0,40000,1,0.25
TELFORD

Figure 8.3 Factory database file

8.2.2.1 Elements of factory file

The format of factory file is given in figure 8.3. The file password is DPLANT the number of the factory being modelled is 1. 372.0 is the value of x-coordinates and 310.0 is the value of y-coordinates. The 40,000 units is the

production capacity of the factory in a modelling period. The 1 is the product number, which is being produced at this plant. The £0.25 is the unit inventory cost for this product for a modelling period to be held at any depot in a distribution system. TELFORD is the place where the factory is located.

8.2.3 Depot database file

The depot file contains the name, location, maximum throughput capacity, fixed cost and handling cost for each depot/ transshipment point. It also

```

WHOUSE
1
1,486.00,236.08,20000.00,0,1500,0.03
3
1,2,1,4
Milton Keynes

```

Figure 8.4 Depot database file

contains the total number of products being modelled and the inventory period for each product at each distribution depot.

8.2.3.1 Elements of depot file

The format of the depot file is shown in figure 8.4. The file password is "WHOUSE" and the total number of distribution depots/transshipment points is 1. The 1 is a number for a distribution depot/transshipment point. The 486.00 is the value of x-coordinate and 236.08 is the value for y-coordinate of depot/transshipment location. The 20,000 is the throughput capacity for depot/transshipment in a modelling period. The 0 shows that this is a distribution depot; a 1 here would show that this is a transshipment point. The £1500 is a fixed cost for a distribution depot in a modelling period, and the £0.03 is the handling cost per unit throughput for this depot. 'Milton Keynes' is the name of the town where the depot is located. The 3 is the maximum

number of products being modelled in this system. The 1 is a warehouse number, 2 is the inventory period for product number 1, (that is, if the modelling is being carried out on weekly basis then 2 week inventory to be kept for product number 1 at distribution depot number 1). The 1 is a inventory period for product number 2 and 4 is the inventory period for product number 3.

8.2.4 Customer database file

The customer file contains the number, location, the demand in a modelling period, and a product number for each customer.

```

CUSTOM
1
1,440.00,150.00,11.00,1

```

Figure 8.5 Customer database file

8.2.4.1 Customer file elements

The customer file is depicted in figure 8.5. The "CUSTOM" is a password for this file and 1 is the maximum number of customers being modelled. The 1 is the customer number. 440.0 is the x-coordinate values and 150.00 is the y-coordinate value for customer locations. The 11.00 is the demand for the customer and 1 is the product number.

8.2.5 Cost database file and its elements

The cost file is depicted in figure 8.6. The "TRANSP" is the password for this file. The 1.25 is a wiggle factor for local delivery and is used to convert the straight line distance into actual distance. The 0.50 is the travelling cost for a local delivery vehicle for one kilometre. The 1200 is the unit capacity for a local delivery vehicle; a full local delivery vehicle is able to move 1200 unit of product from one place to another. The 1350 is the capacity unit for

TRANSP	Password
1.25	Wiggle factor for local delivery
0.50	Rate per kilometre
1200	Local delivery vehicle capacity
1350	Trunking vehicle capacity
0	Trunking cost per volume
0.50	Trunking cost per volume per distance
1.15	Trunking wiggle factor
0	Local trunking cost per volume
0.50	Local trunking cost per distance
100	Trunking speed Kilometre per hour
10	Trunking drivers per hour
30	Trunking drivers night out cost
100	Local delivery stem speed kilometre per hour
60	Zone speed
0.25	Unloading time per drops
10	Maximum hours allowed to work per day
1.8	Local delivery constant
30	Extra days cost
1	Inventory constant

Figure 8.6 Cost database file

trunking vehicle. The 0 is the value which is being used for calculating the trunking cost which depends on the volume. The value 0.50 is the trunking vehicle cost to travel for one kilometre. The 1.15 is the wiggle factor value, which is used to convert the straight line distance between factory and depot to actual distance. The 0 and 0.50 represent the same as previously but in this case apply to local trunking, the trunking between depot and transshipment point. The value 100 is the speed in kilometres per hour for trunking between factory to depot and from depot to transshipment point. The 10 is the number of hours a trunking driver is allowed to drive in a day. The value 30 is the night out cost for the trunking driver. The 100 is the local delivery stem speed - the speed between depot to local delivery region - in kilometres per hour. The 60 is the local delivery vehicle speed in a delivery zone. The 0.25 hour is the unloading time for each customer. The 10 is the maximum number of hours a local delivery driver can drive in one day. The

1.8 is the multiplying constant for local delivery. The 30 is the value for night out cost for local deliver driver. The 1 is the inventory constant.

8.2.6 Hazard database file

```

HAZARA
1
1 520 170 30 1.25

```

Figure 8.7 Hazard data base file

This file contains the number, location, radius of the region and penalty factor for each hazard in the modelling area.

8.2.6.1 Hazard file Elements

The file format and its records are given in figure 8.7. The "HAZARA" is the password for this file. The 1 is the value for total number of hazards in the modelling region. The 1 is the number for the hazard, each hazard having its own identifying number. The 520 is the value for the x-coordinate and 170 is the value for the y-coordinate of the centre of the hazard. The 30 is the value in same unit as location of the radius from central point of hazard. The 1.25 is the penalty factor, which is used to multiply the hazard distance.

8.2.7 Barrier database file

This file contains the information for each barrier in the modelling system. It includes barrier number, X and Y co-ordinates of both end of barriers, and the penalty factor of the barrier distance.

8.2.7.1 Barrier file Elements

The barrier file format is given in figure 8.8. The "BRIDGE" is the password

BRIDGE
1
1 150 100 375 185 1

Figure 8.8 Barrier database file

word for the barrier file. The 1 is the value for the total number of barriers in the modelling area. The 150 is the value for the x-coordinate and 100 is the value for the y-coordinate of one end of the barrier. The 375 and the 185 are the x-coordinate and the y-coordinate of the other end of the barrier. The 1 is the penalty factor by which extra distance for barrier is being multiplied.

All the input files have a similar approach to read in the data. This approach was adopted to make the data preparation facility as simple as possible. Therefore a general data flow diagram is given in figure 8.9

8.3 Allocation

As described in the last chapter, LSM takes an overall system approach to allocate a customer. This approach is taken to overcome the sub-optimal allocation.

LSM is designed on the basis of small independent modules of subroutines. Each subroutine does its own bits and passes the parameter to next subroutine. This approach was adopted because each module was tested extensively before it was linked to developed program. The debugging, compiling and testing of the module at the development stages was much easier because only small parts were being tested. This approach is particularly useful for developing software using a micro-computer. Modification and addition in future will be much easier. Most importantly of

8-14

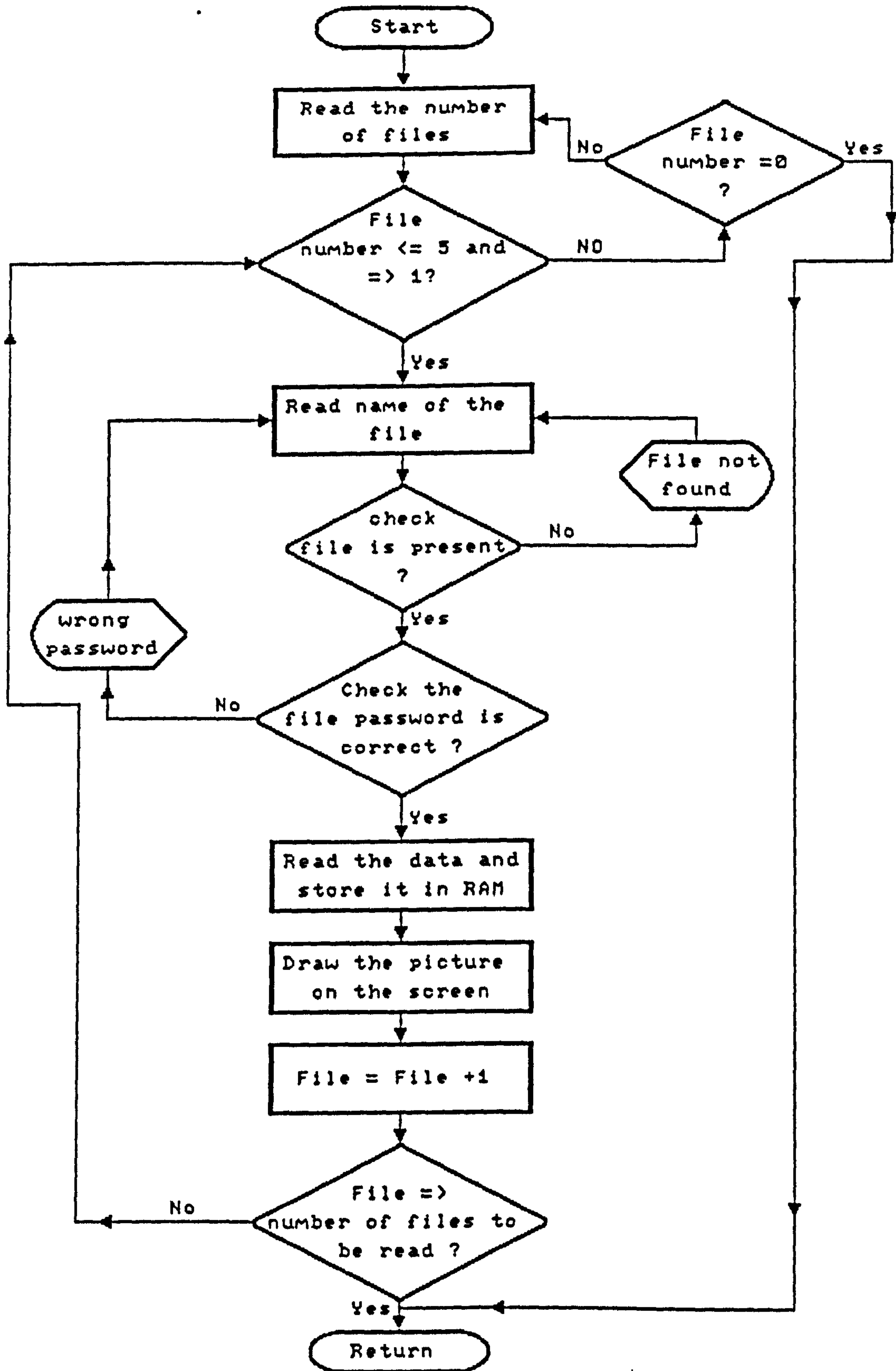

Figure 8.9 Readfile Structure

all, this is the logical way to develop computer programs.

Therefore an allocation program is a combination of many different subroutines. Before customers are allocated to a serving facility, the program verifies that there is an adequate production at source points and enough throughput capacity is available at the distribution depot/transshipment points to serve the market area.

8.3.1 READCA

The data flow diagram of subroutine READCA is depicted in figure 8.10. This subroutine verifies that there is sufficient production and throughput capacity available to satisfy the demand. It aggregates the demand for all the customers on a product basis and accumulates all the production for same product from all the source points. This is repeated for all the products and if total production of any product is less than its demand, the program will stop. If production satisfies all the demand, then a subroutine will add all the throughput capacity available at each depot/transshipment point. If total throughput capacity is less than total customers demand, the program will terminate because the basic assumption made at the development of this model is that all the customers' demand must be satisfied.

8.3.2 CUSORT

This subroutine is employed to sort the customers into descending order on the basis of their total distance. This is used for allocation purposes because LSM will start allocation by the furthest customer in the system (reason explain in chapter seven). This subroutine is called in to the program at the beginning of the allocation of customers and during the program when a depot/transshipment point is deleted or added to or moved in the system.

The data flow diagram is given in figure 8.11. For each customer, it calculates his distance from each depot and transshipment point in the system. It adds this distance to those of all the other depot/transshipment

8-16

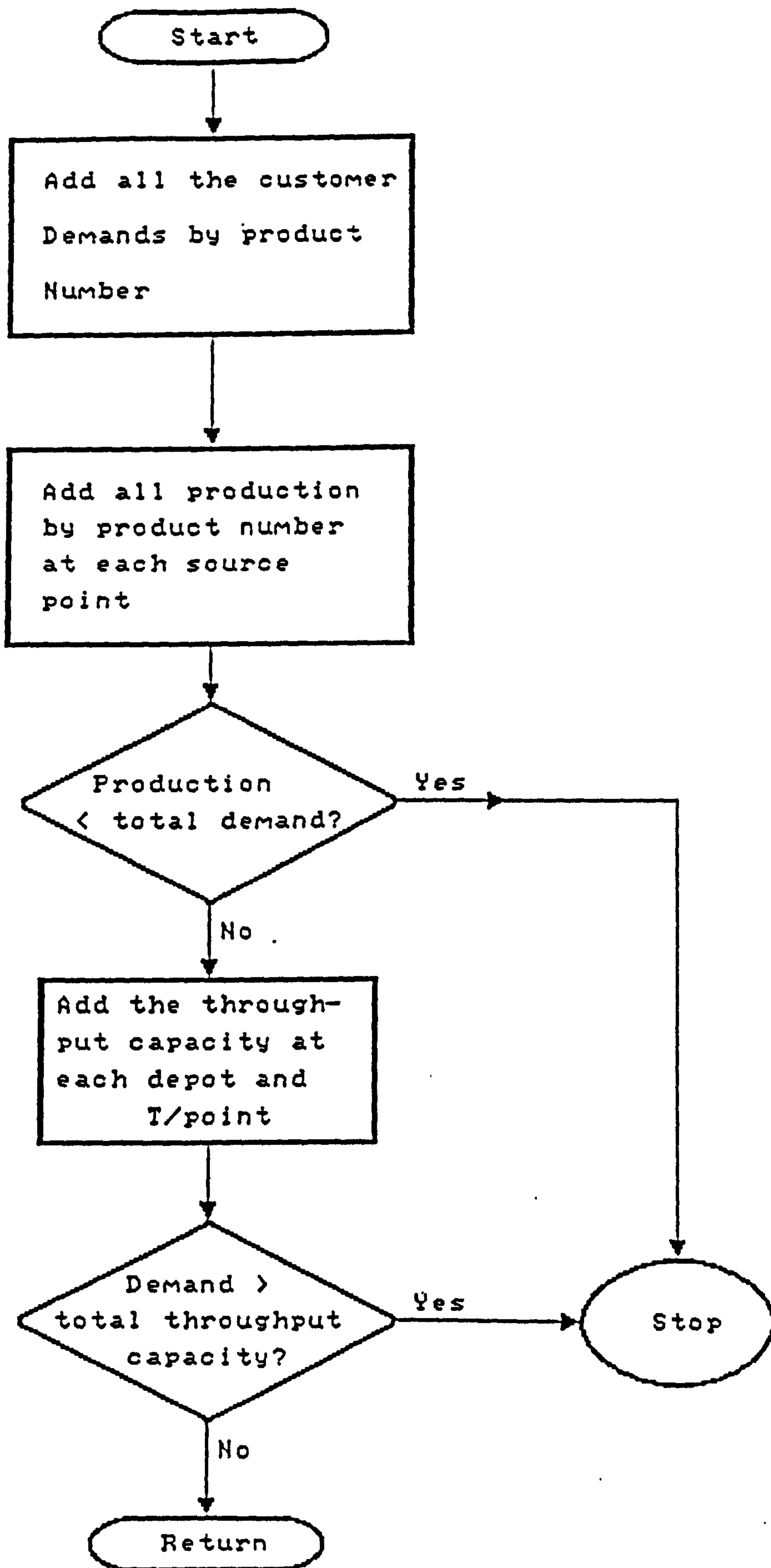

Figure 8.10 Subroutine Readca

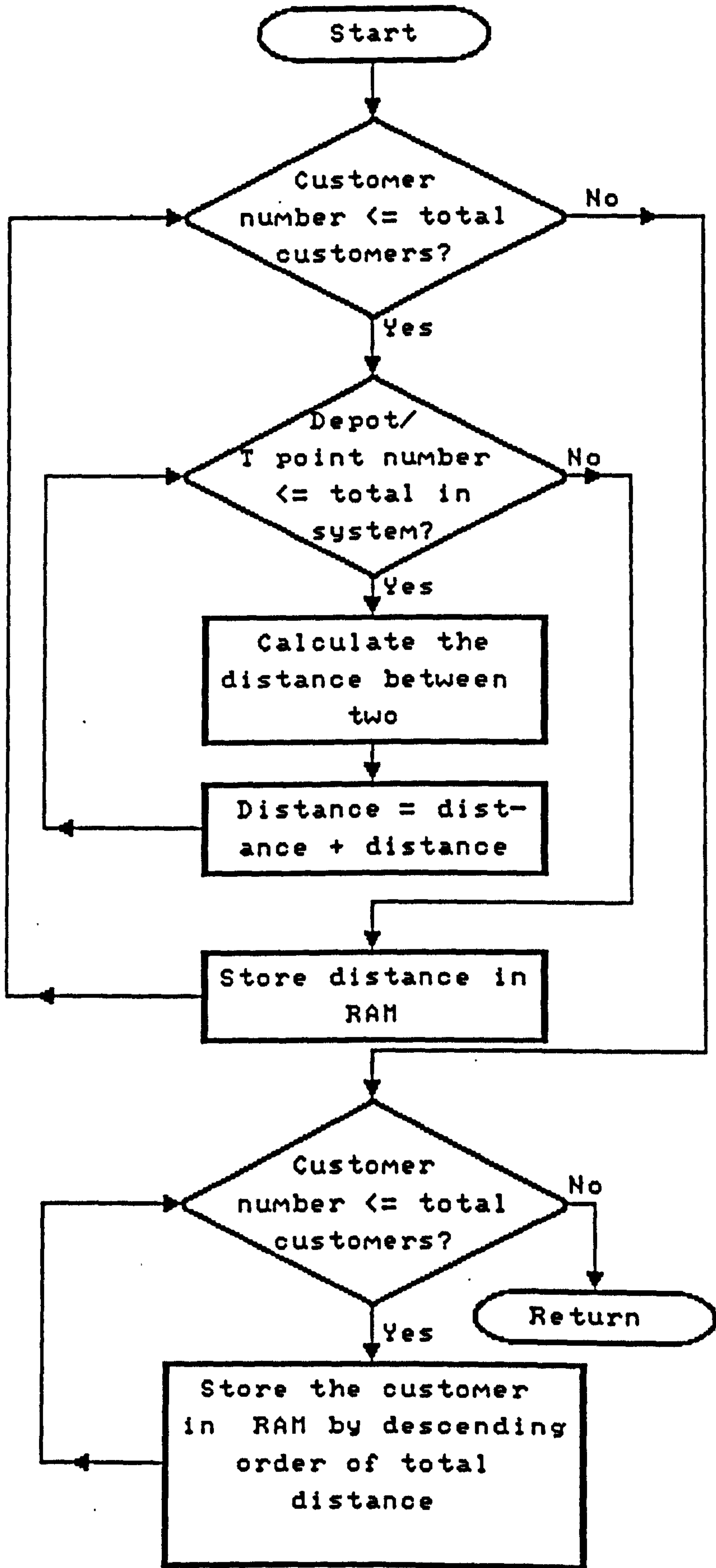

Figure 8.11 Subroutine Cusort

point and stores it them in an array. It then simply sorts them on ascending orders of total distance.

8.3.3 ALOCAT

Subroutine ALOCAT is a main subroutine used for the allocation of customers to depots and transshipment points. Its principle objective is to allocate the customer to the cheapest depot or transshipment point by building network links from source point to customer. The data flow diagram of the subroutine is shown in figure 8.12. Before allocating each customer it performs decision checks such as:

- is the customer located in the modelling area ?
- is there a demand for the customer ?
- has the customer been deleted during the modelling process ?

It then passes control of the program to the subroutines ALO1 and ALO2.

8.3.4 ALO1

Subroutine ALO1 is used to calculate the serving cost for a customer from source points through all the depots and transshipment points in the system. The data flow diagram is shown in figure 8.13. Before it calculates the cost, it checks that the depot/transshipment point is located in the modelling area, that it has adequate throughput capacity and that it was not deleted during the modelling process. It calculates the straight line distance from the depot/transshipment point. If there are any hazards in the system then it checks whether the delivery vehicle has to pass through this region and if it does then it adds any extra distance which may result due to the hazard. If any barrier is in the system and it is located in the path of the delivery, it will add the extra distance which will incurred by going round the barrier. The data flow diagram is given in figure 8.14. ALO1 uses this total distance to calculate the local delivery cost. It also adds the handling cost at the depot/transshipment point to the total cost.

8-19

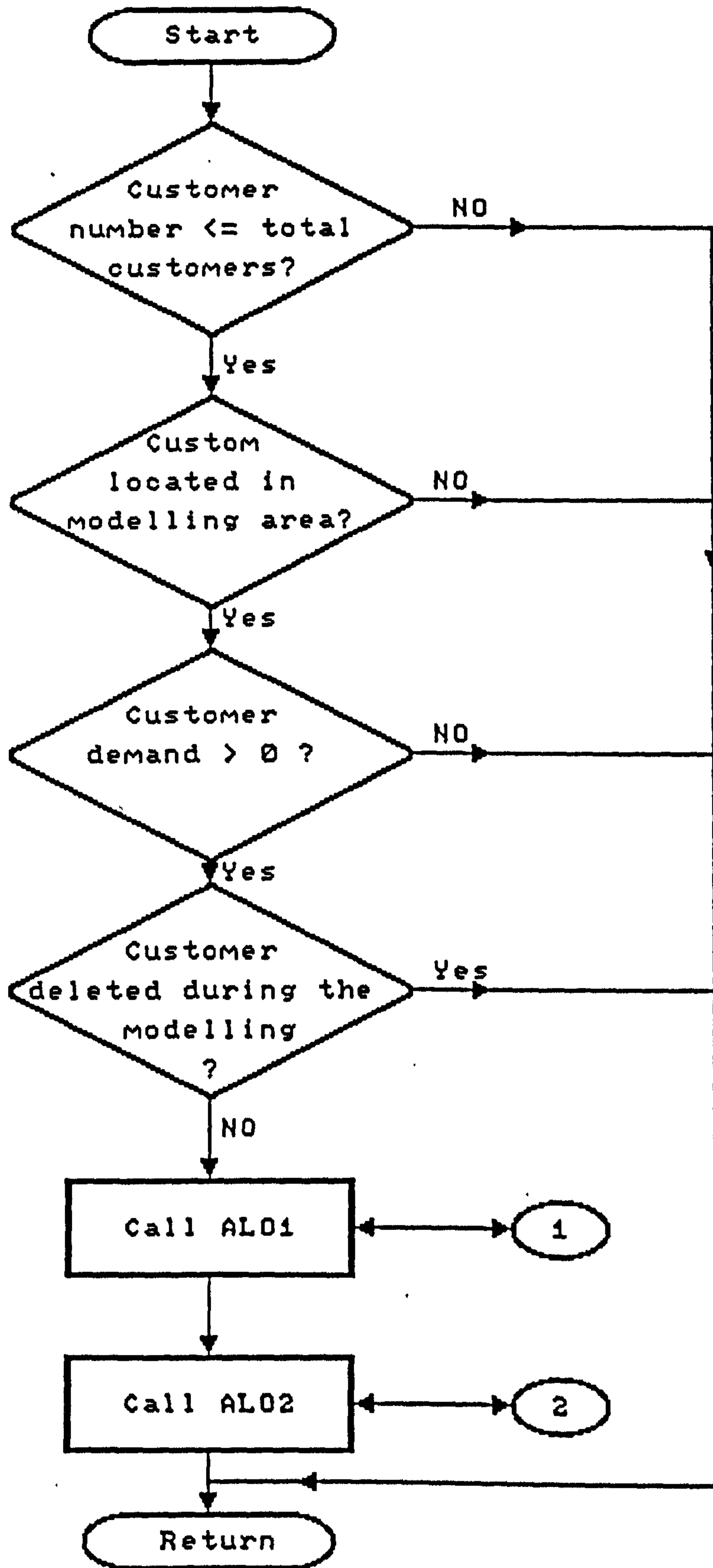

Figure 8.12 Subroutine Allocat

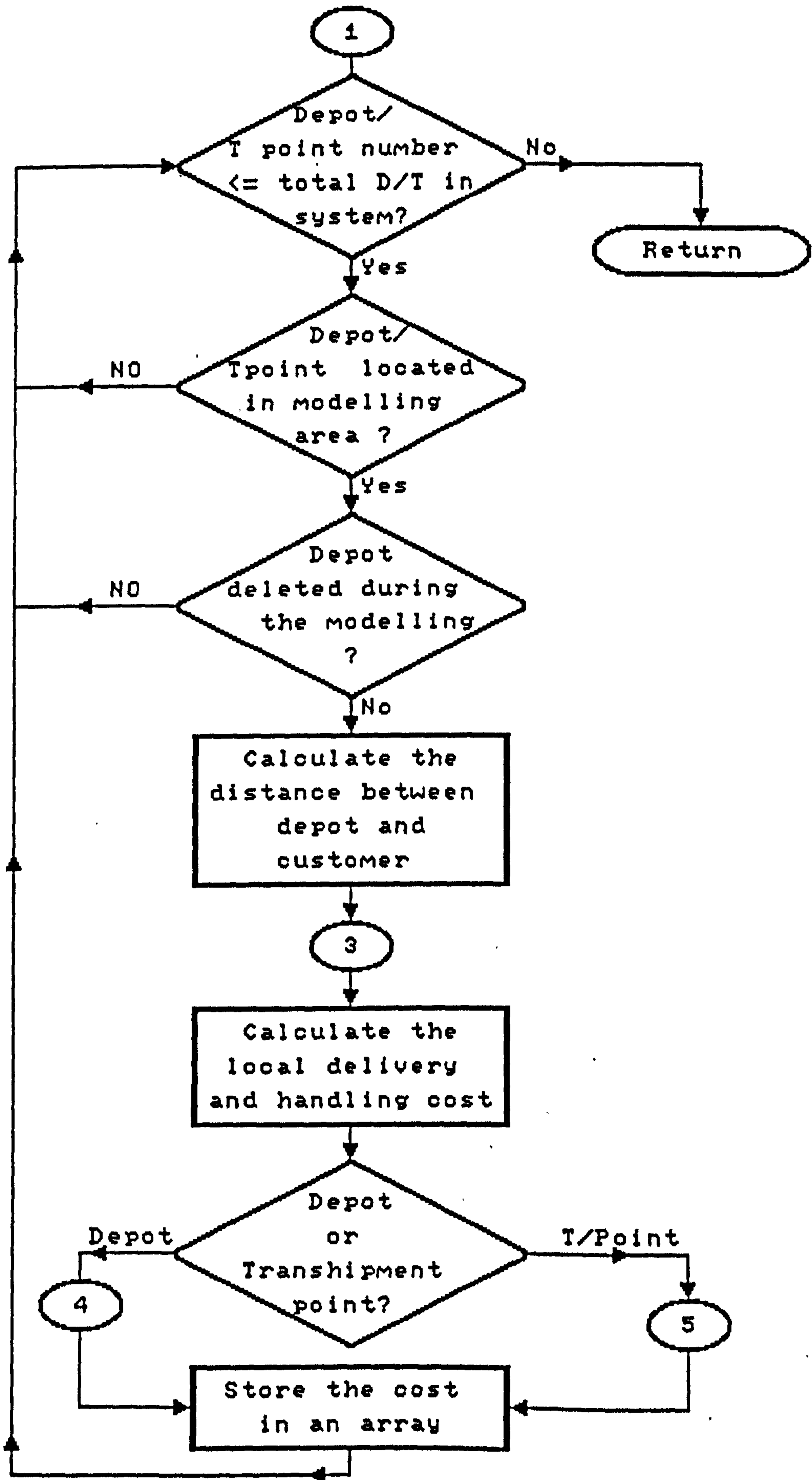

Figure 8.13 Subroutine A101

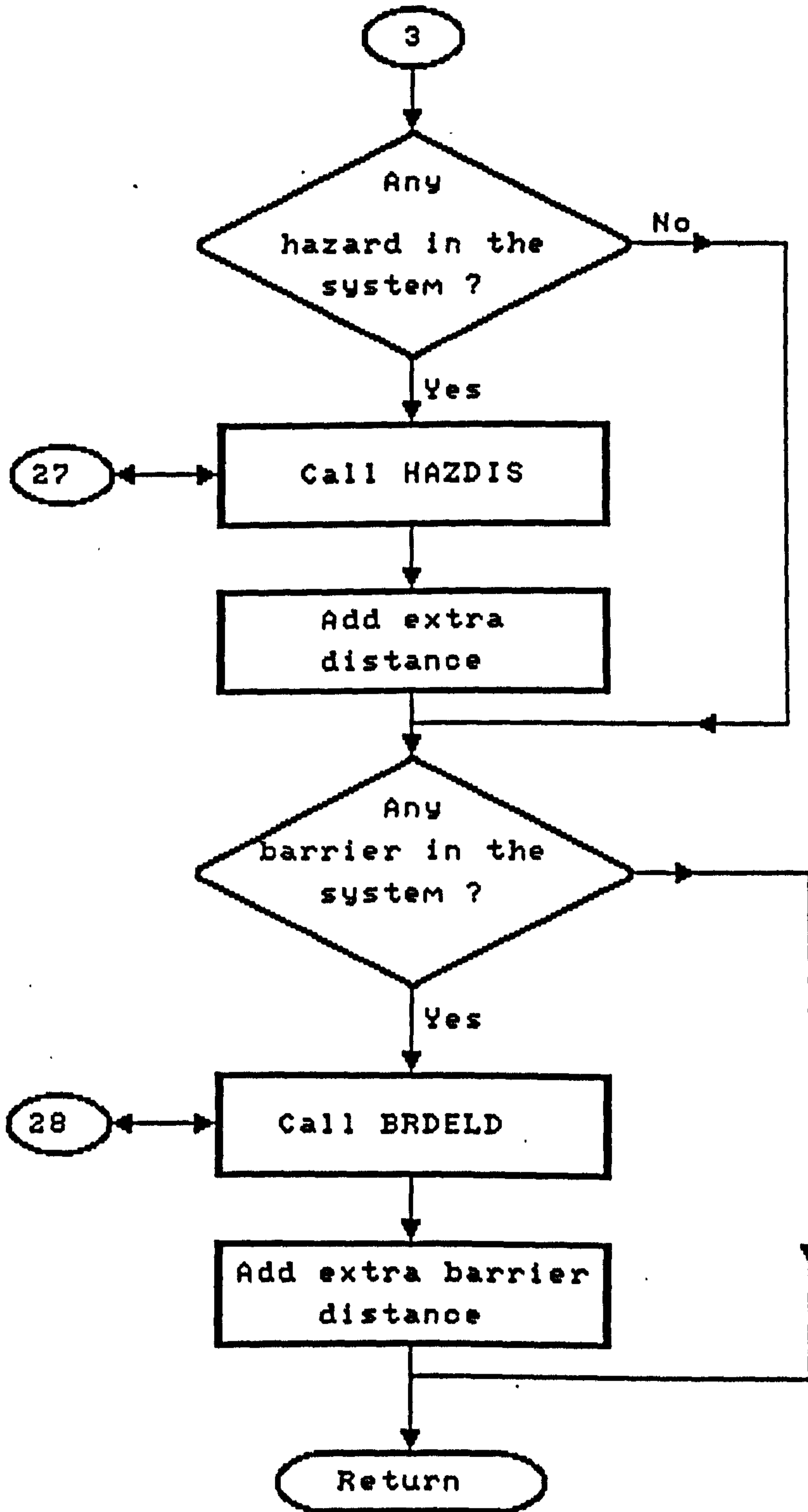

Figure 8.14 Subroutine A101

8.3.5 HAZARD

Subroutine Hazard is employed to calculate the extra distance which may be incurred due to a congested area in the modelling region. The data flow diagrams of this subroutine are shown in figures 8.15, 8.15a and 8.15b. The subroutine calculates the gradient of the line. For each hazard it checks whether it is situated in the path of the vehicle, calculates the distance which is added by this hazard and then multiplies this distance by the hazard penalty factor.

8.3.6 BRDELD

Subroutine Brdeld is used to calculate the extra distance due to rivers or mountains. The area cannot be crossed but it can be passed at either end of the barrier. The data flow diagrams of this subroutine are given in figures 8.16, 8.16a, 8.16b, 8.16c and 8.16d. The decision checks are carried out to determine that the barrier or barriers are located in the path between customer and depot. If they are situated in the path then this subroutine adds the extra incurred distance.

8.3.7 CUSF

The CUSF is used to calculate the cost of delivery from source point to depot for a customer demand. The calculated cost is used for the allocation of customers to the cheapest depot or transshipment point. The data flow diagram of the subroutine is given in figure 8.17. Before building a network path between depot and source point, CUSF makes such check decisions as

- Is the source point is located in the modelling area ?
- Does it produce the appropriate product required by the customer ?
- Does the source point have the sufficient of product to meet the required demand?

It also checks for hazards and barriers in the network path. It compares the

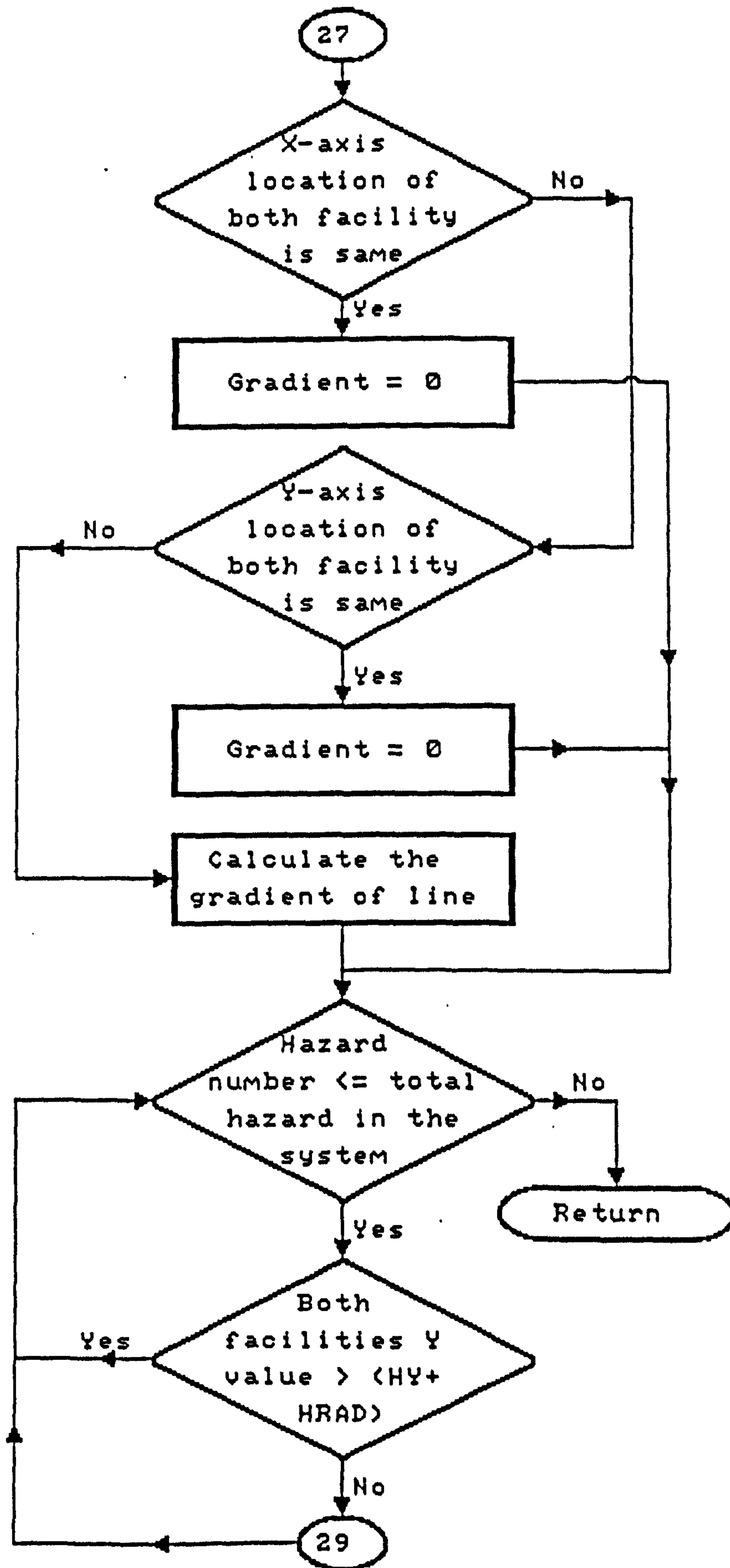

Figure 8.15 Subroutine Hazard

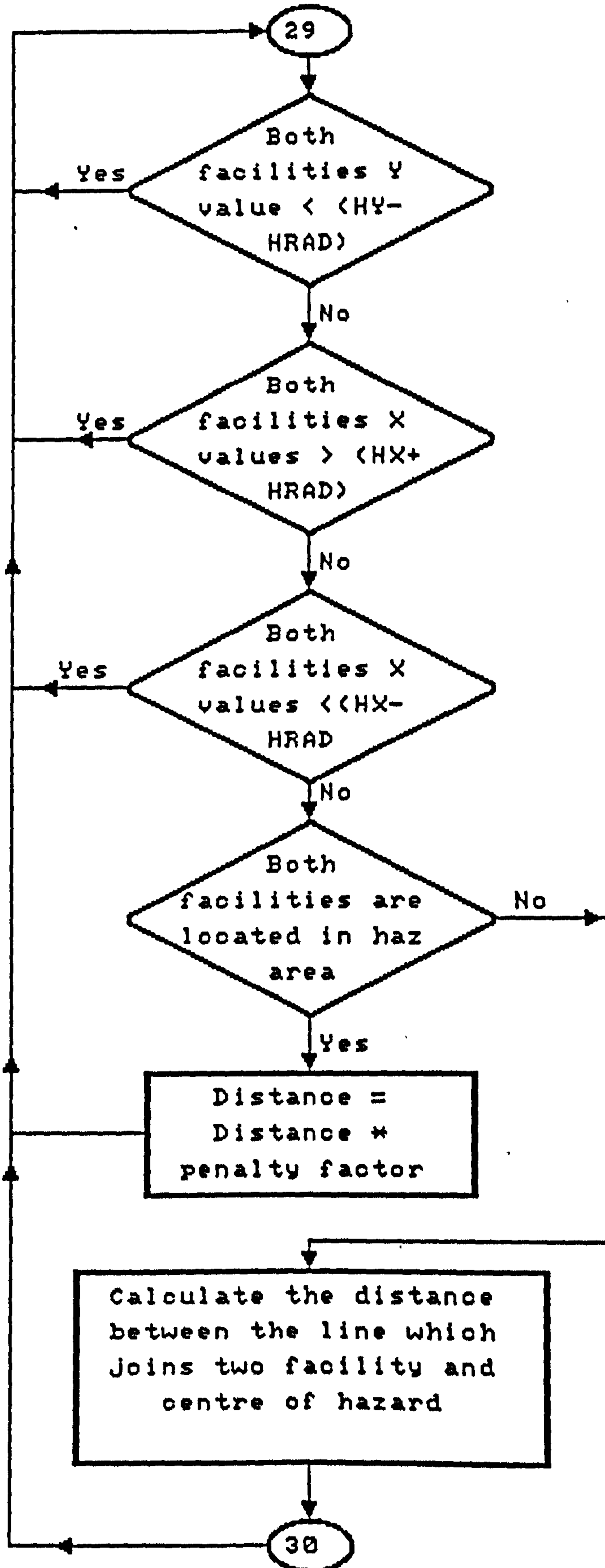

Figure 8.15a Subroutine Hazard

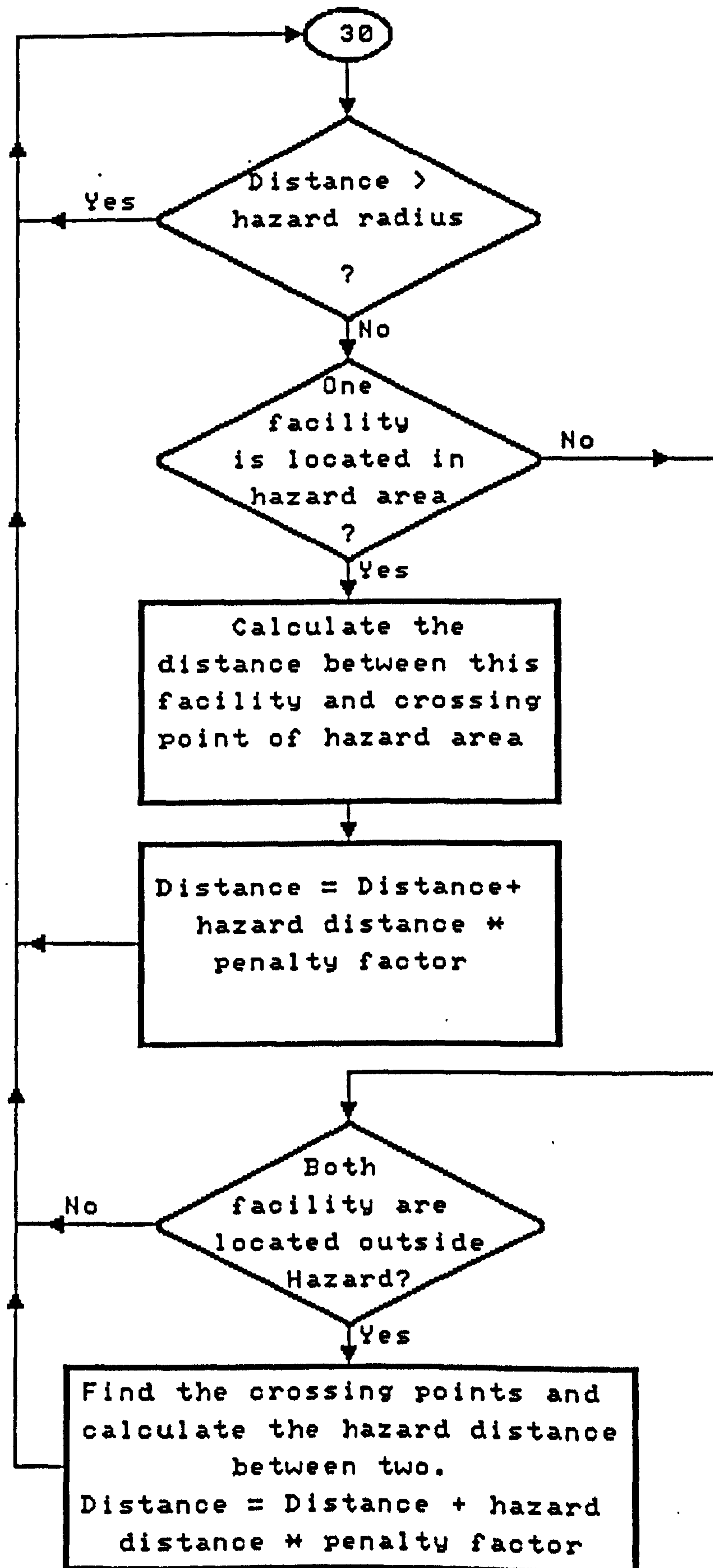

Figure 8.15b Subroutine Hazard

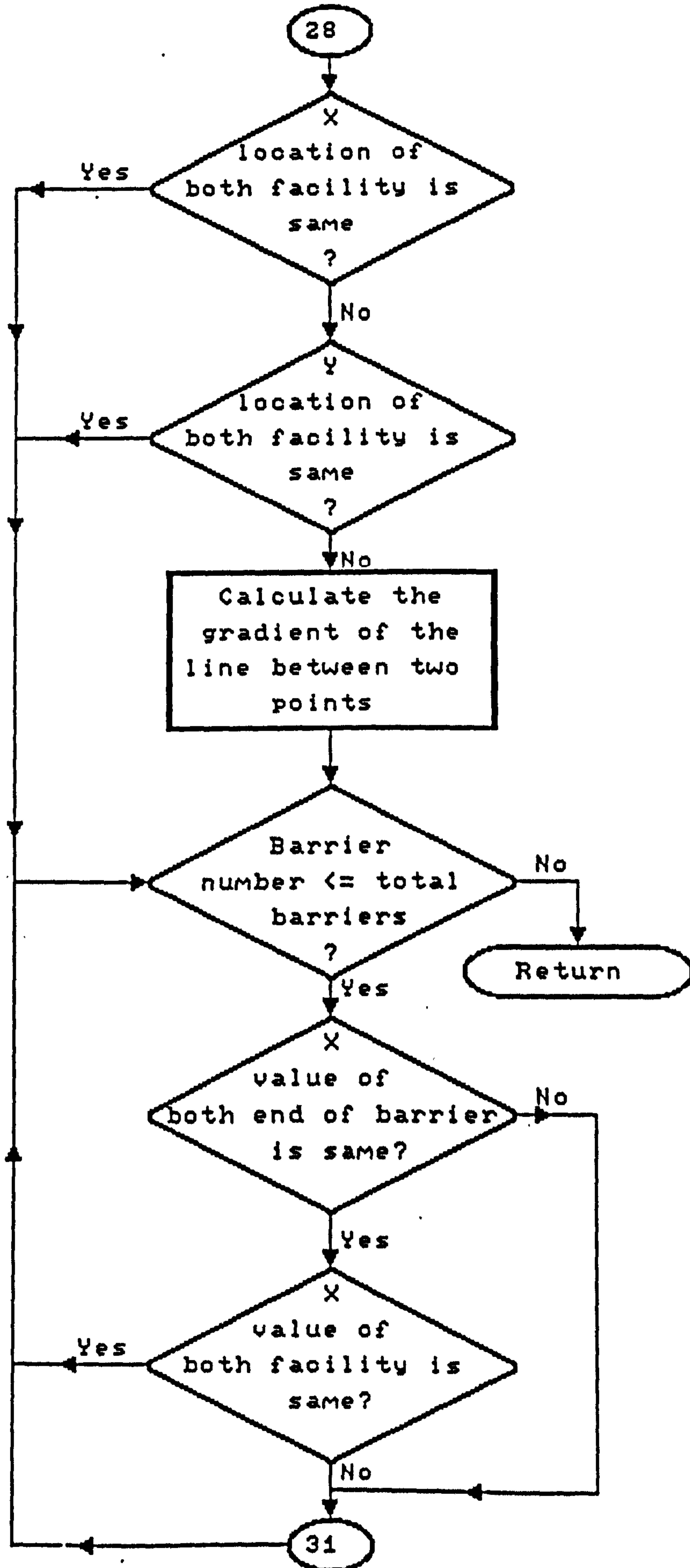

Figure 8.16 Subroutine Brdeld

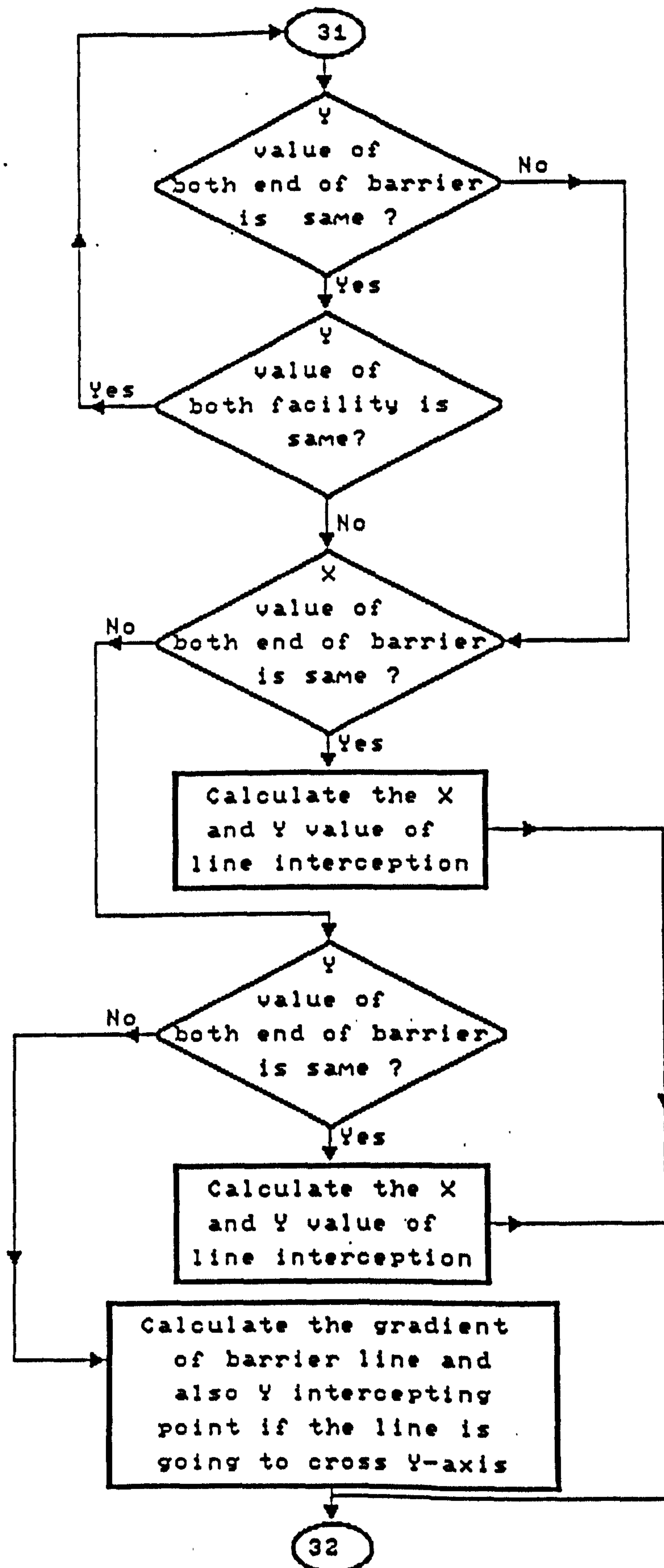

Figure 8.16a Subroutine Brdeld

8-28

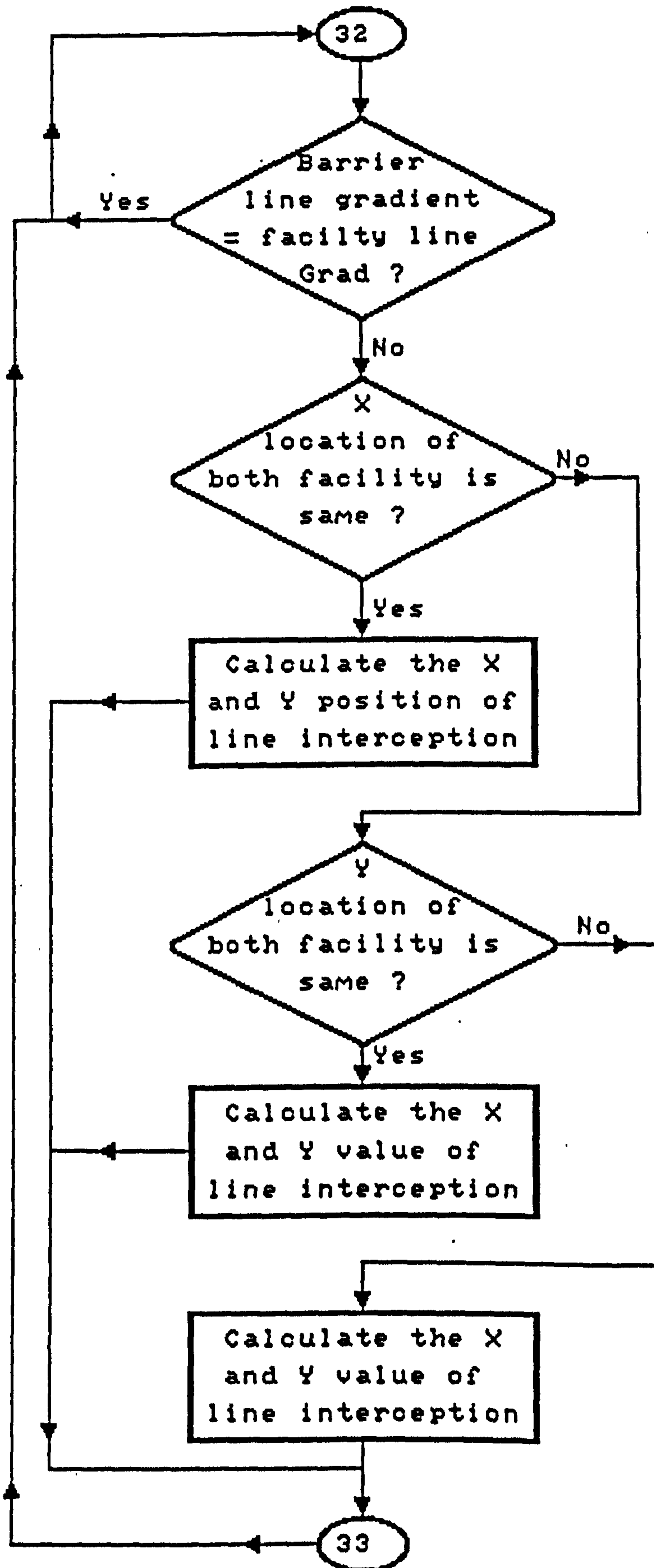

Figure 8.16b Subroutine Brdeld

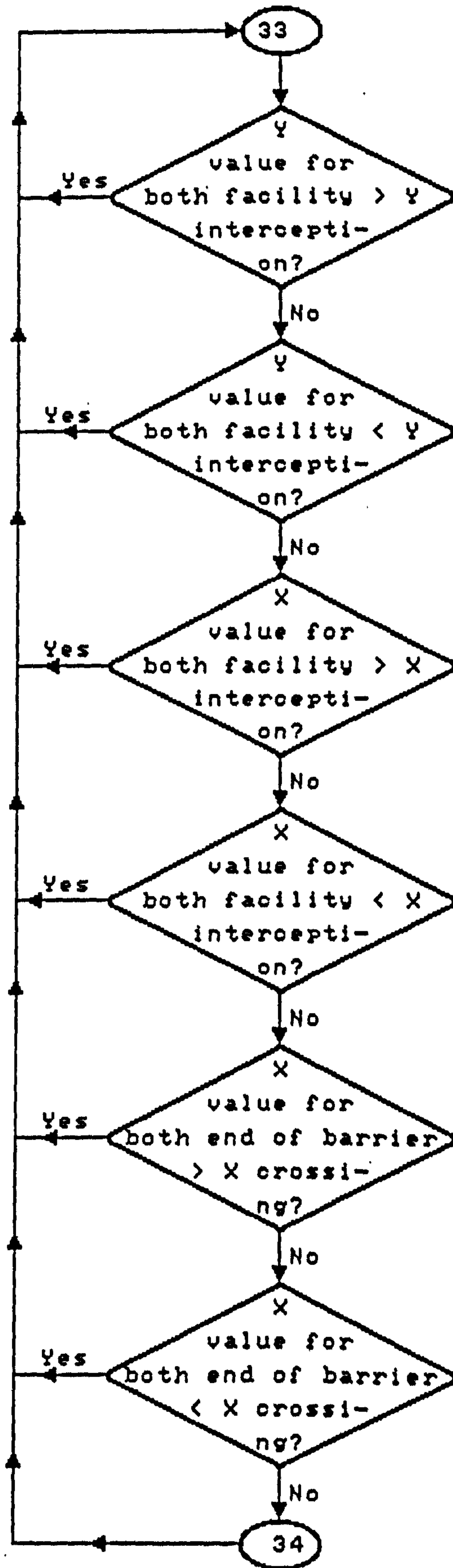

Figure 8.16c Subroutine Brdeld

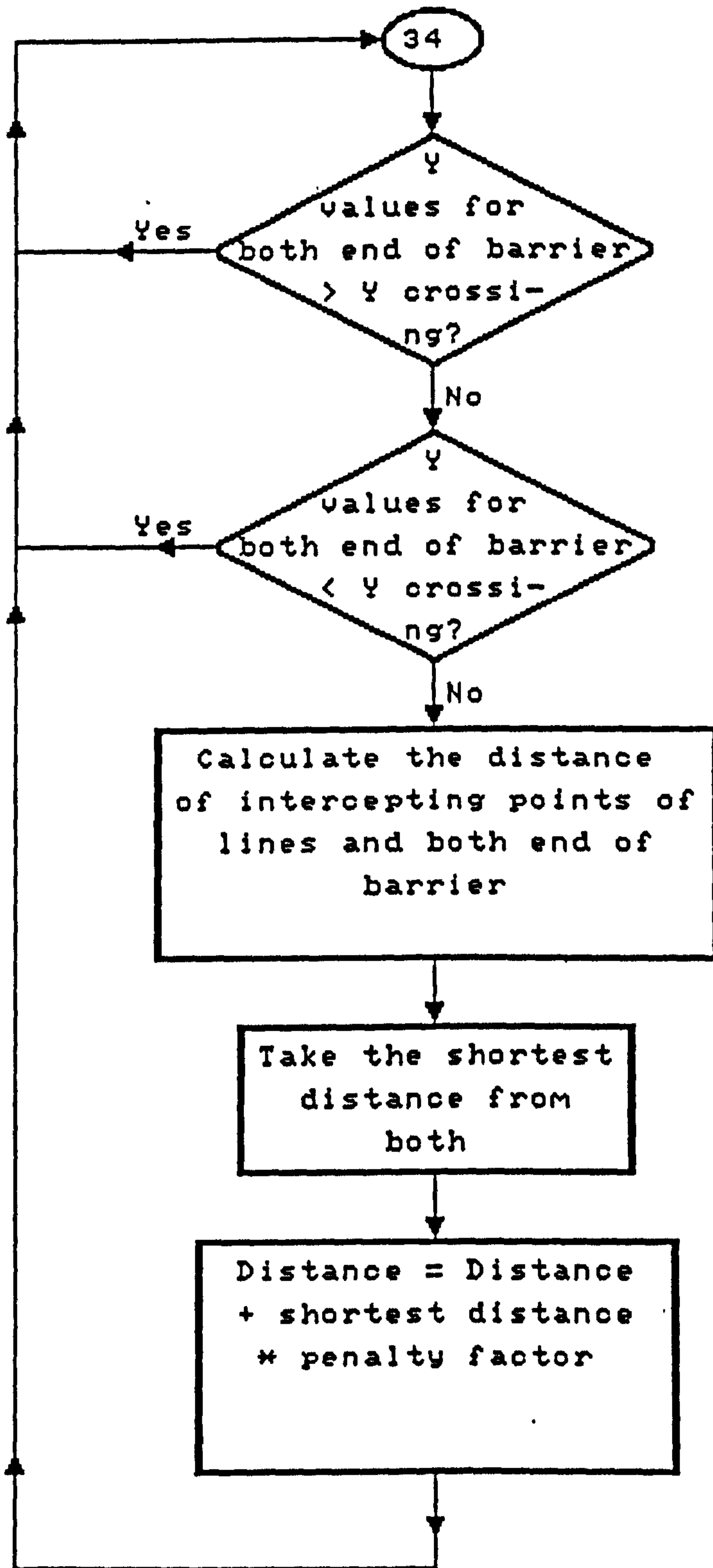

Figure 8.16d Subroutine Brdeld

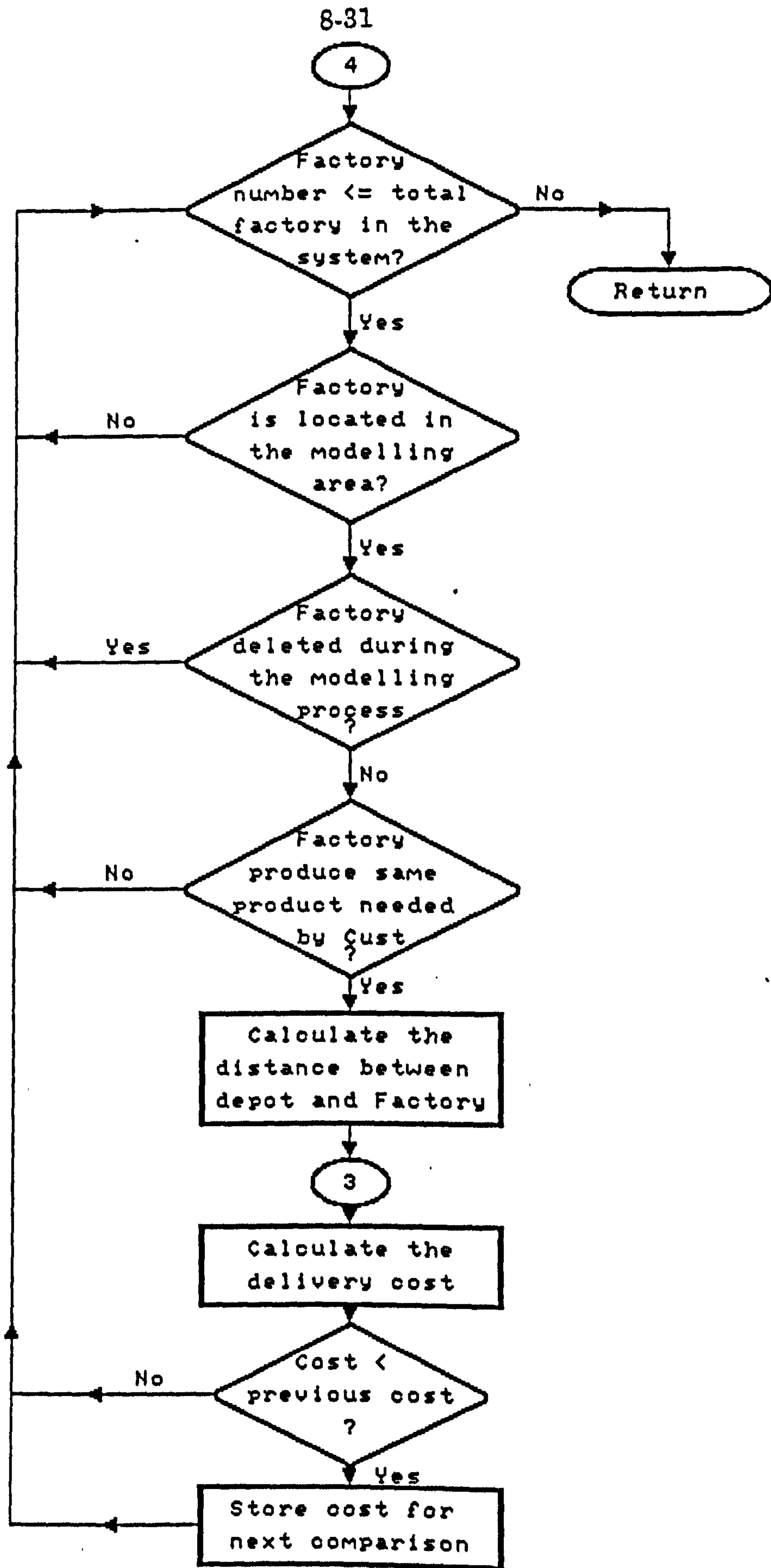

Figure 8.17 Subroutine Cusf

cost from all the source points and allocates to the cheapest source.

8.3.8 TRAD

If a customer is allocated to a transshipment point, this subroutine is used to calculate the cost of delivery from the depot to the transshipment point including the handling cost at the depot. The data flow diagram is shown in figure 8.18. It also makes a decision check on the depot to ensure that it is located in the modelling area and that it has enough throughput capacity to serve the customer.

8.3.9 ALO2

Subroutine ALO2's data flow diagram is shown in 8.19. This subroutine sorts the network's calculated costs in ascending order and allocates the customer to the cheapest depot. It calculates the local delivery cost between the cheapest depot and customer. It stores the cost to be displayed later.

8.3.10 AL1

Subroutine AL1 is used to draw a boundary line around the distribution depots and transshipment points. The data flow diagram is given in figure 8.20. For each depot and transshipment point, it makes a decision check that the depot is used to serve the customers. The cursor is moved on to a distant customer, then by using cross product vector formula (chapter six) it finds the most outer right hand side customer and draws the line between two. It continues using the formula draw lines between two points until it returns to point where it started.

8.3.11 TWALO

This subroutine is used to allocate the transshipment point to a warehouse/distribution depot. The data flow diagram is shown in figure 8.21. For each product it adds the demand for all the customers that are served by this transshipment point. It uses subroutine TW1 to build a product flow network from source point to this transshipment point. It uses subroutine

8-33

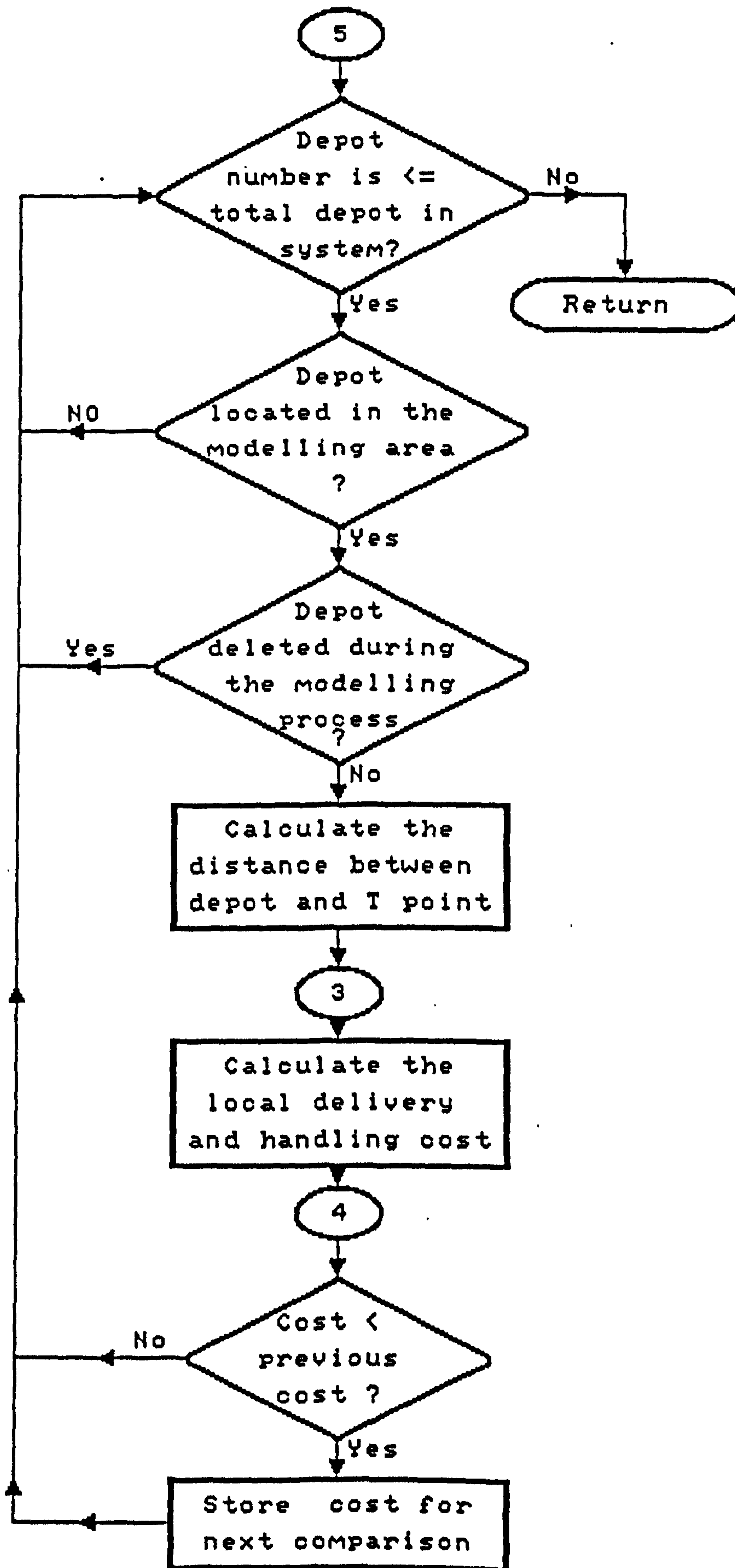

Figure 8.18 Subroutine Trad

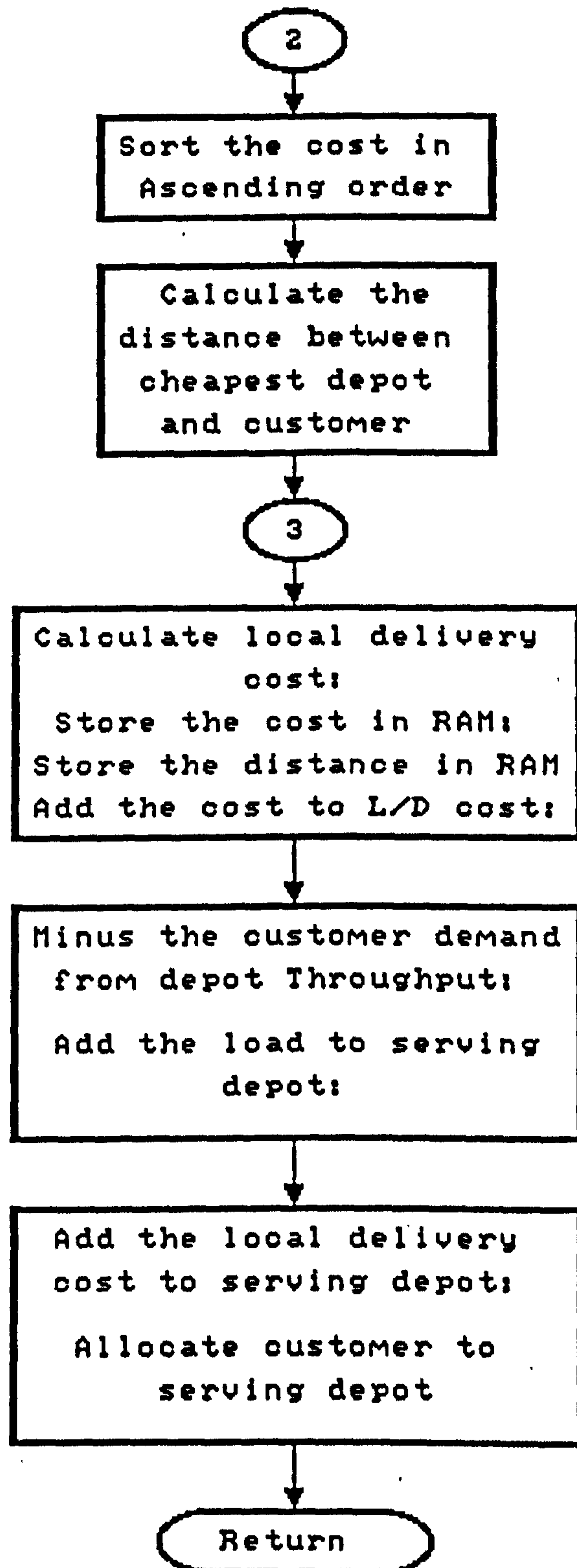
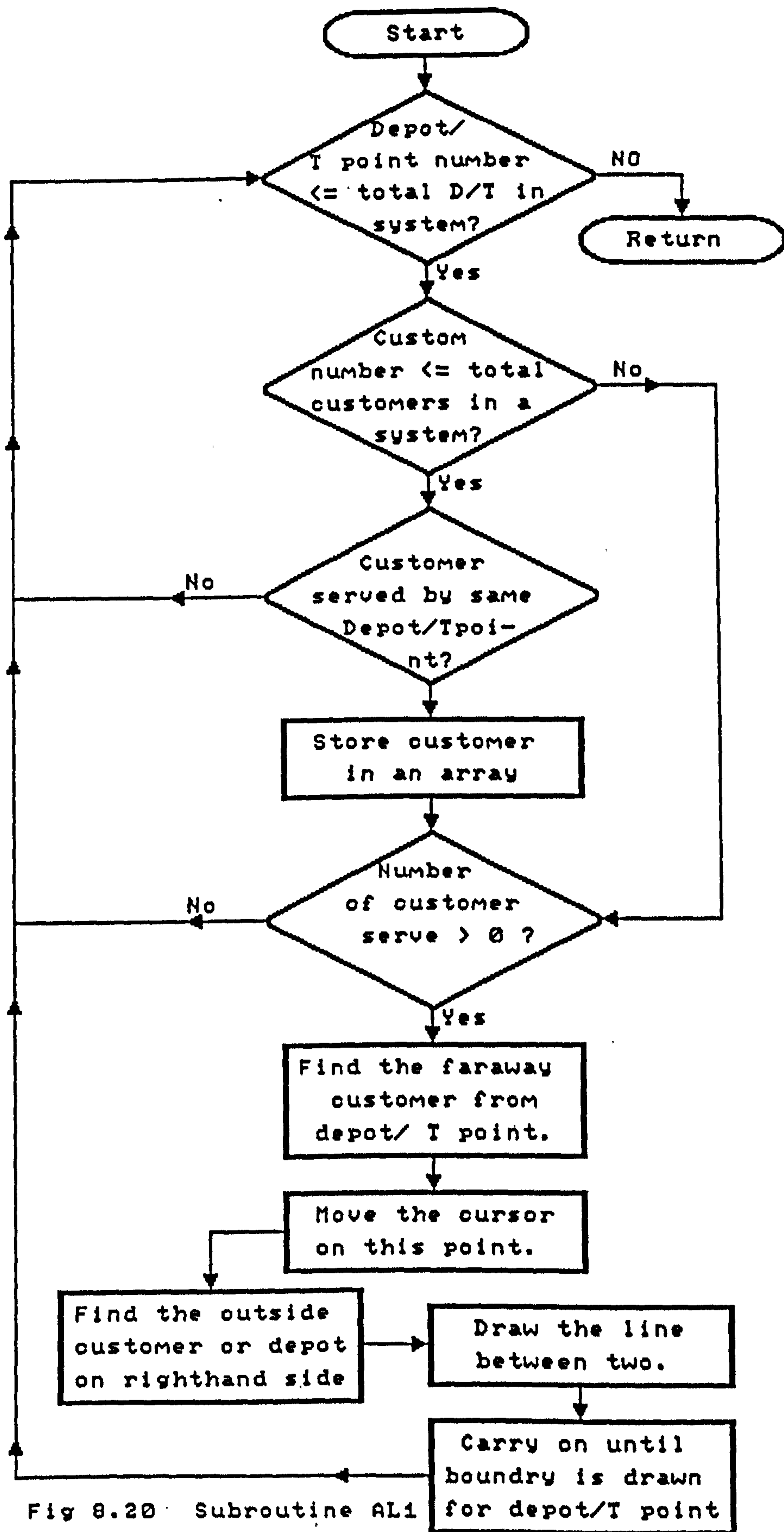

Figure 8.19 Subroutine A1o2



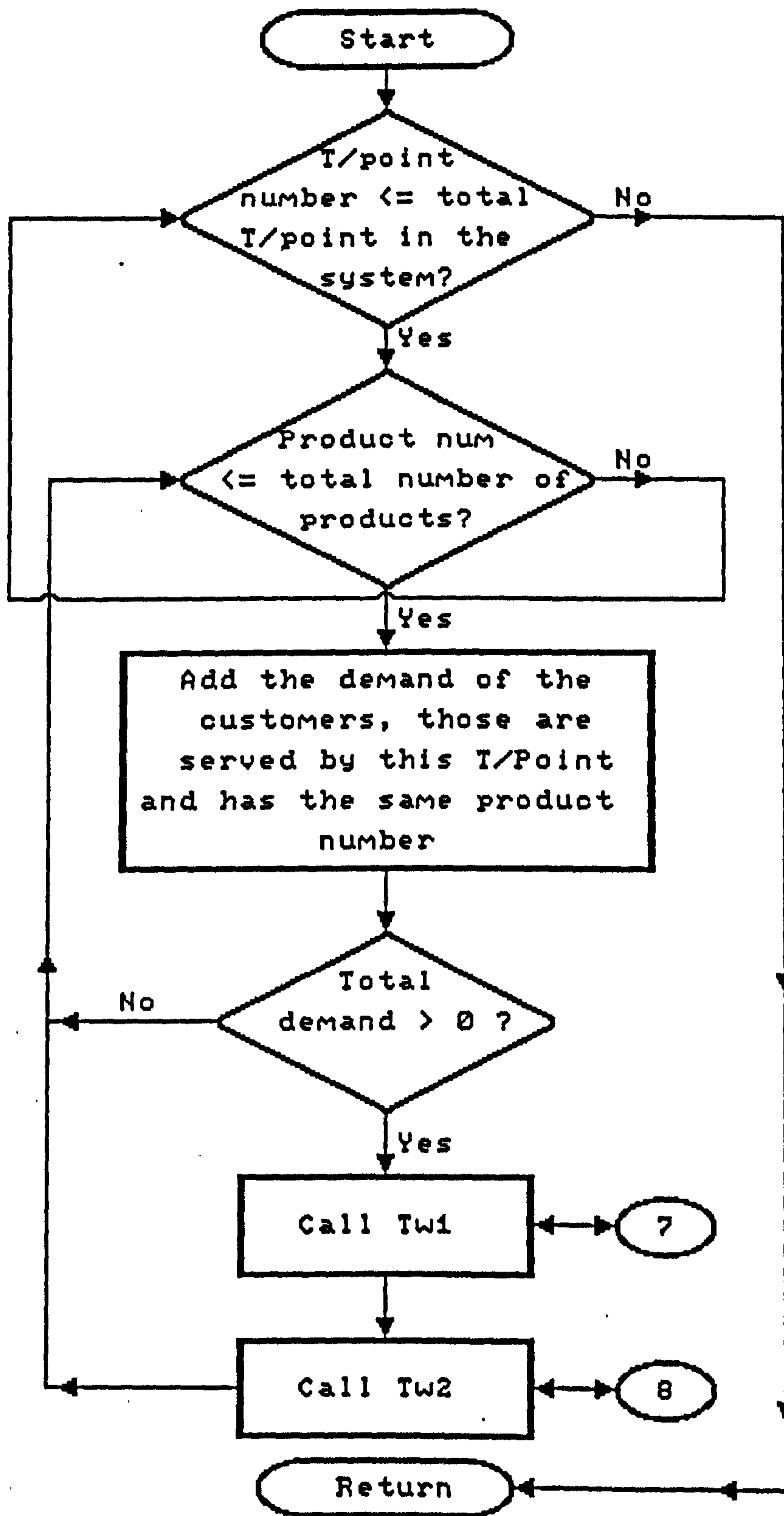

Figure 8.21
Subroutine TWALO

TW2 to allocate to the cheapest depot.

8.3.12 TW1

The data flow diagram of subroutine TW1 is shown in figure 8.22. Before building a product network flow, it performs the decision checks that a depot is located in the modelling area and that it was not deleted during the modelling process. TW1 employs the subroutine CUSF to calculate the cost between depot and source point. TW1 itself calculates the cost from all the depots to this transshipment point and stores them in an array.

8.3.13 TW2

Subroutine TW2 is used to sort the costs in ascending order. It calculates the costs between the transshipment point and the cheapest depot. It adds this cost to the total local trunking cost, adds the transshipment trunking cost, subtracts the transshipment demand from depot throughput and draws the lines between transshipment point and depot, which reflects the volume flow of products. The data flow diagram is given in figure 8.23.

8.3.14 PDALO

Subroutine Pdalo is used to allocate the depot to the cheapest source point in the logistic system. The data flow diagram for Pdalo is shown in figure 8.24. For each depot the subroutine checks that this product passes through the depots. If it does then pdalo adds all the demand for this product and passes the control to the subroutine PD1 and PD2.

8.3.15 PD1

Subroutine PD1 is used to calculate the cost for a product from all its source point to the distribution depot. Before calculating the cost it makes decision checks such as whether the source point is located in the modelling area, that it was not deleted during the modelling process, and it produces the same product. The data flow diagram is shown in figure 8.25.

8-38

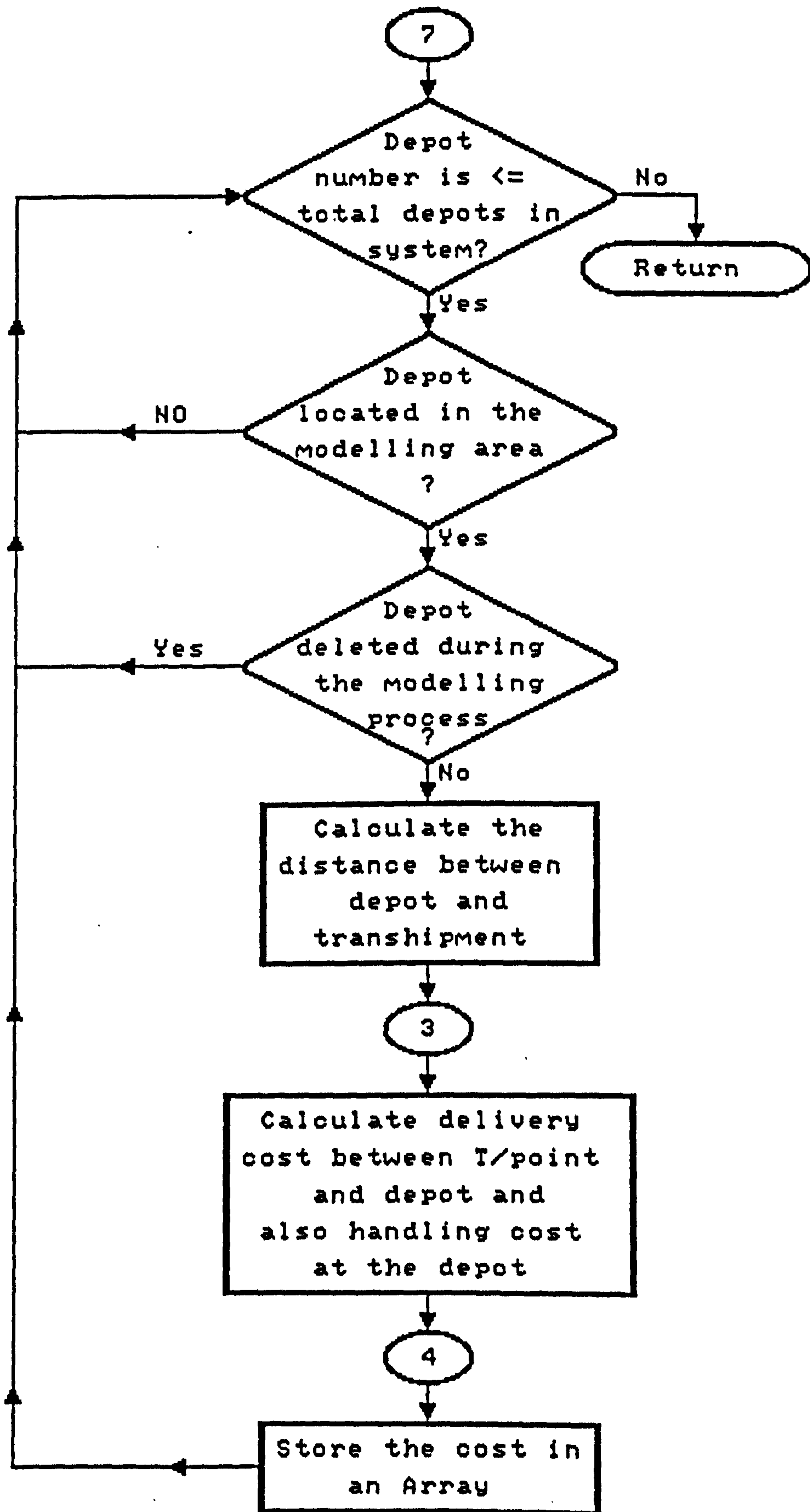

Figure 8.22
Subroutine IW1

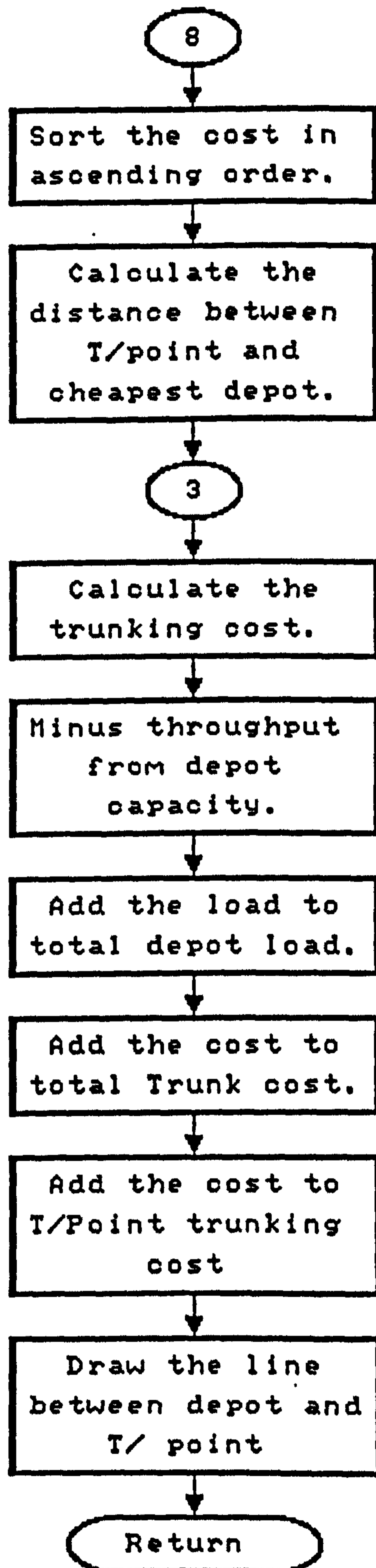

Figure 8.23

Subroutine TH2

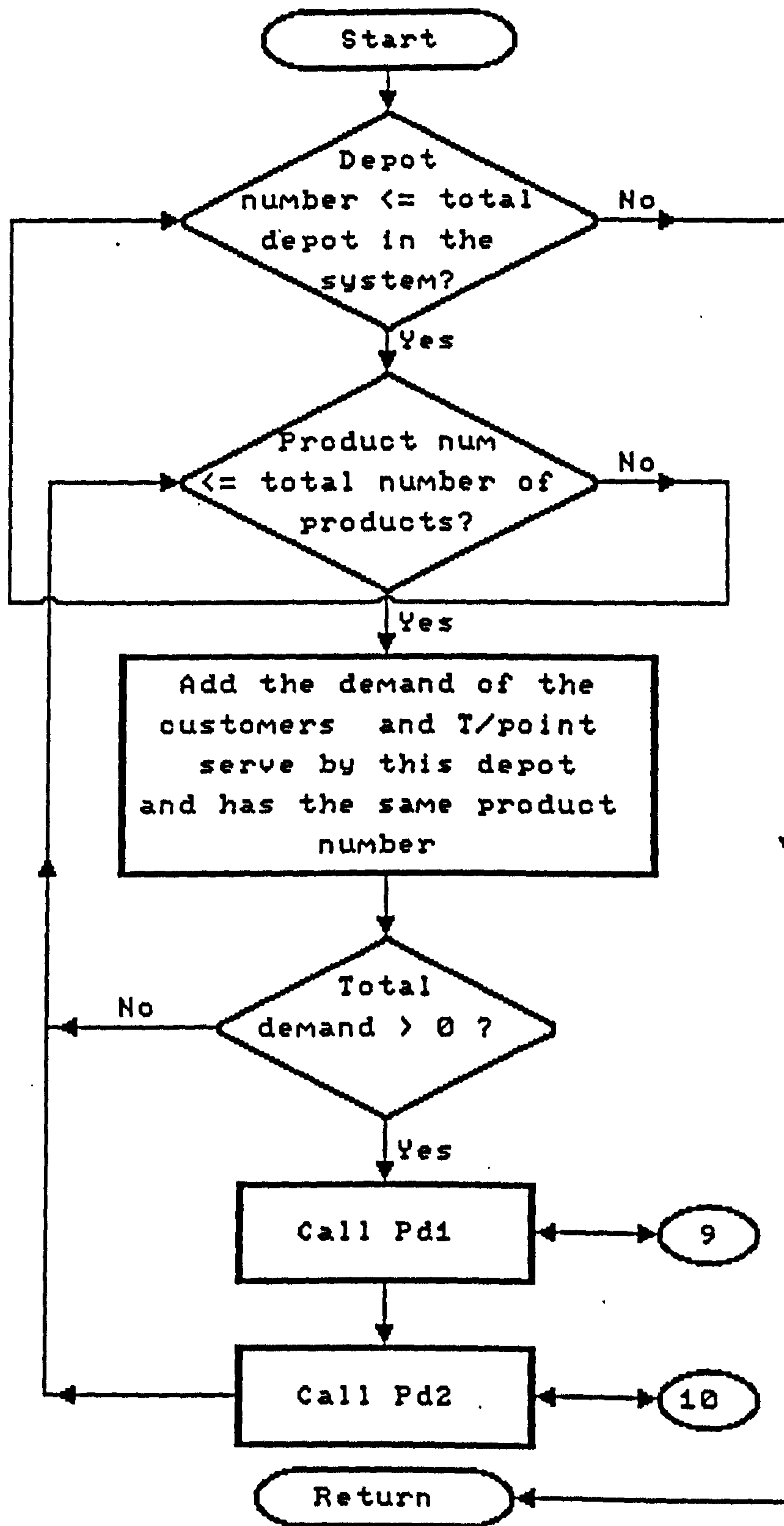

Figure 8.24

Subroutine PDALD

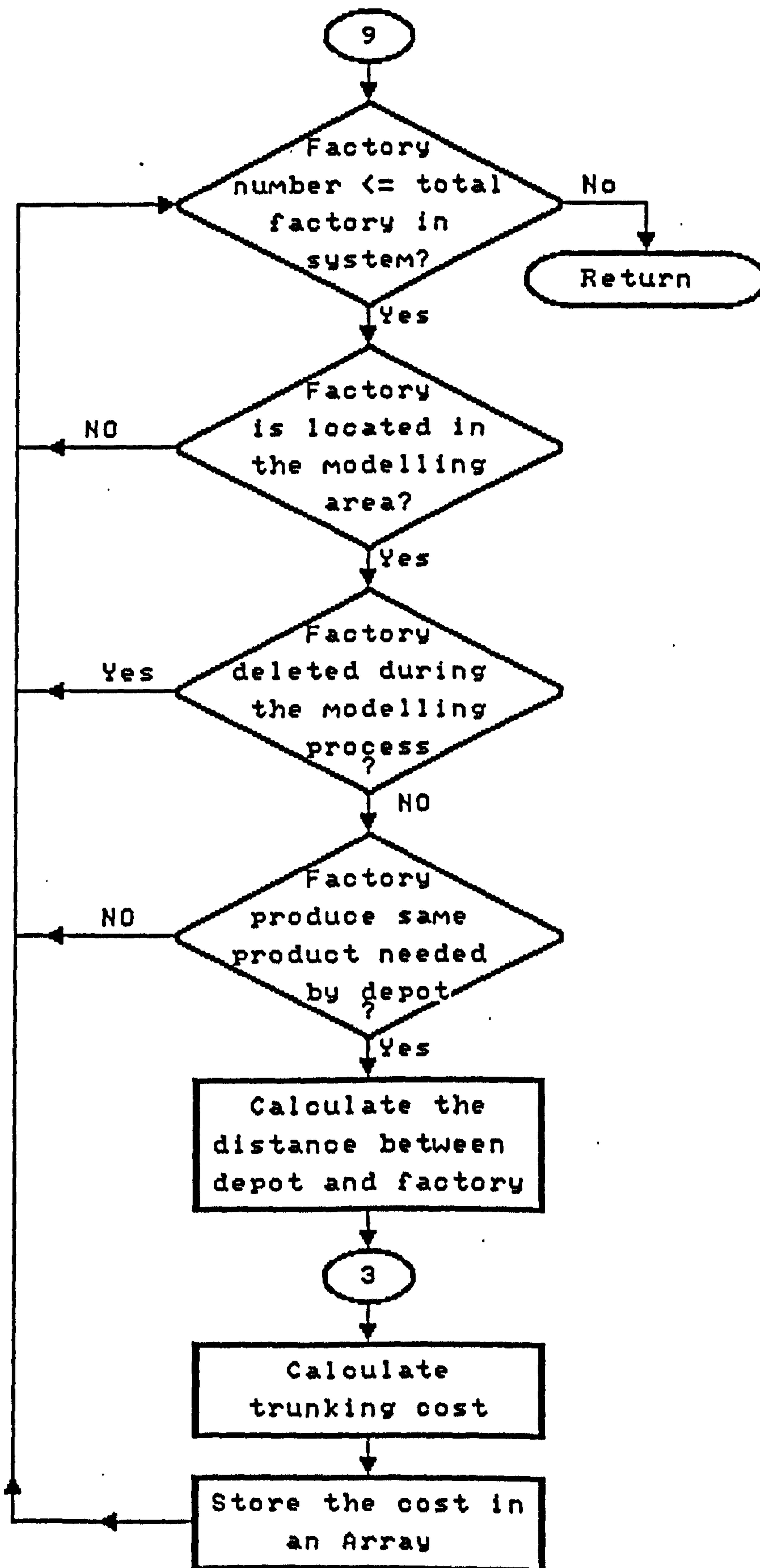

Figure 8.25

Subroutine PD1

8.3.16 PD2

Subroutine PD2 is used to allocate the depot to the cheapest source point. If demand is not satisfied by the cheapest source point then it will find the next source point, continue thus until demand is satisfied. The data flow diagram is given in figure 8.26.

8.4 Costs

The algorithm for all the cost functions is given in chapter six. In this chapter the data flow diagrams are given.

8.4.1 INCOS

Subroutine Incos is used to calculate the inventory cost at each distribution depot. Inventory cost is product dependent and each depot is capable of holding the inventory for more than one product if it is instructed to do so.

This subroutine first finds the amount of a particular product is being passed through a depot. It then multiplies this amount by the number of modelling periods it is being held as an inventory. This total product is then multiplied by the cost of the product to be held as a inventory in a modelling period. The process continues for all the products in the distribution system. The data flow diagram is given in figure 8.27.

8.4.2 LODECO

Lodeco is used to calculate the local delivery cost. The algorithm for this subroutine is given in chapter seven. The data flow diagram is shown in figure 8.28.

8.4.3 TRDECO

Trdeco is employed to calculate the trunking cost between transshipment point and depot and from source point to distribution depot. The data flow diagram is given in figure 8.29.

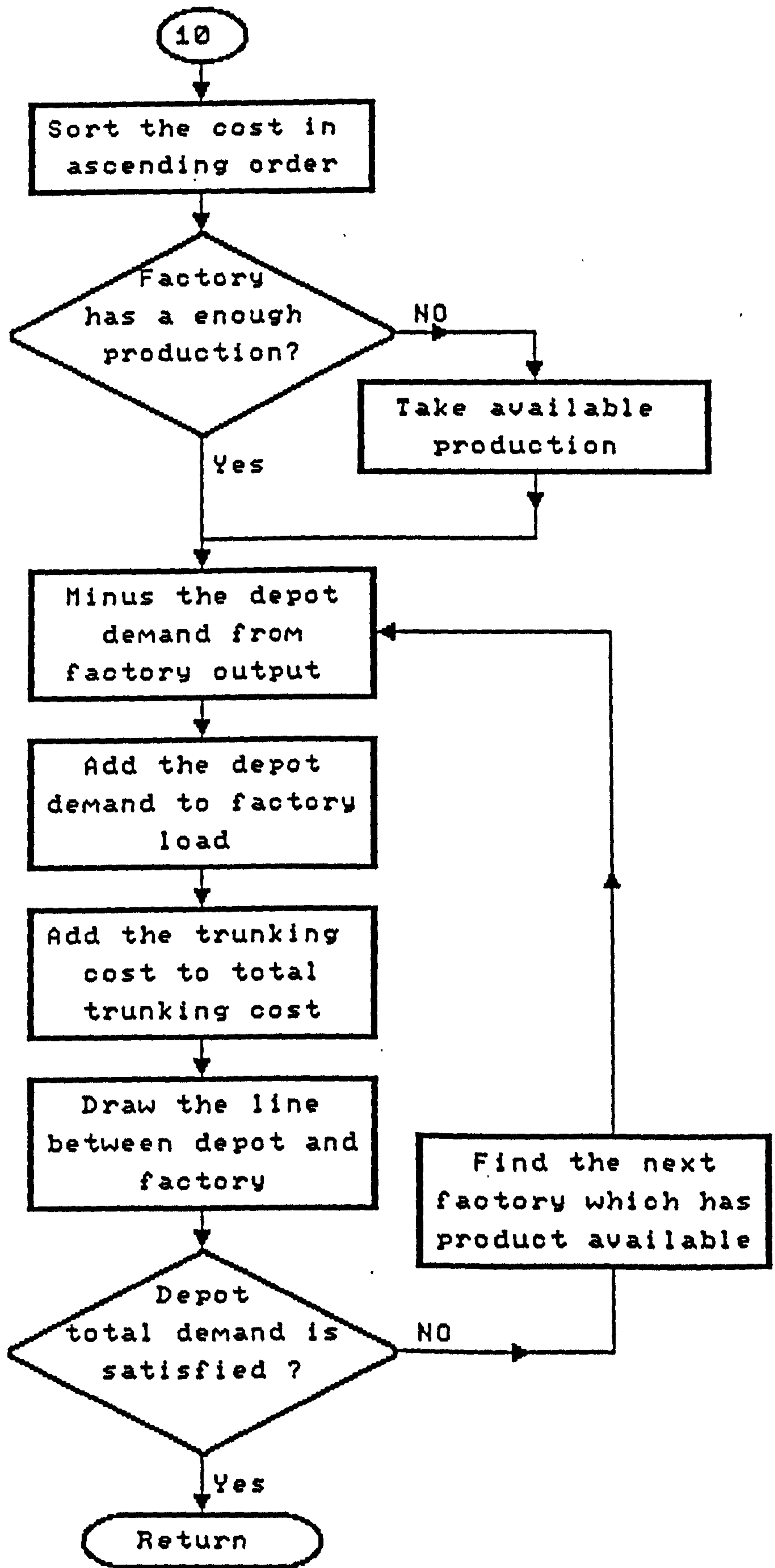

Figure 8.26

Subroutine PD2

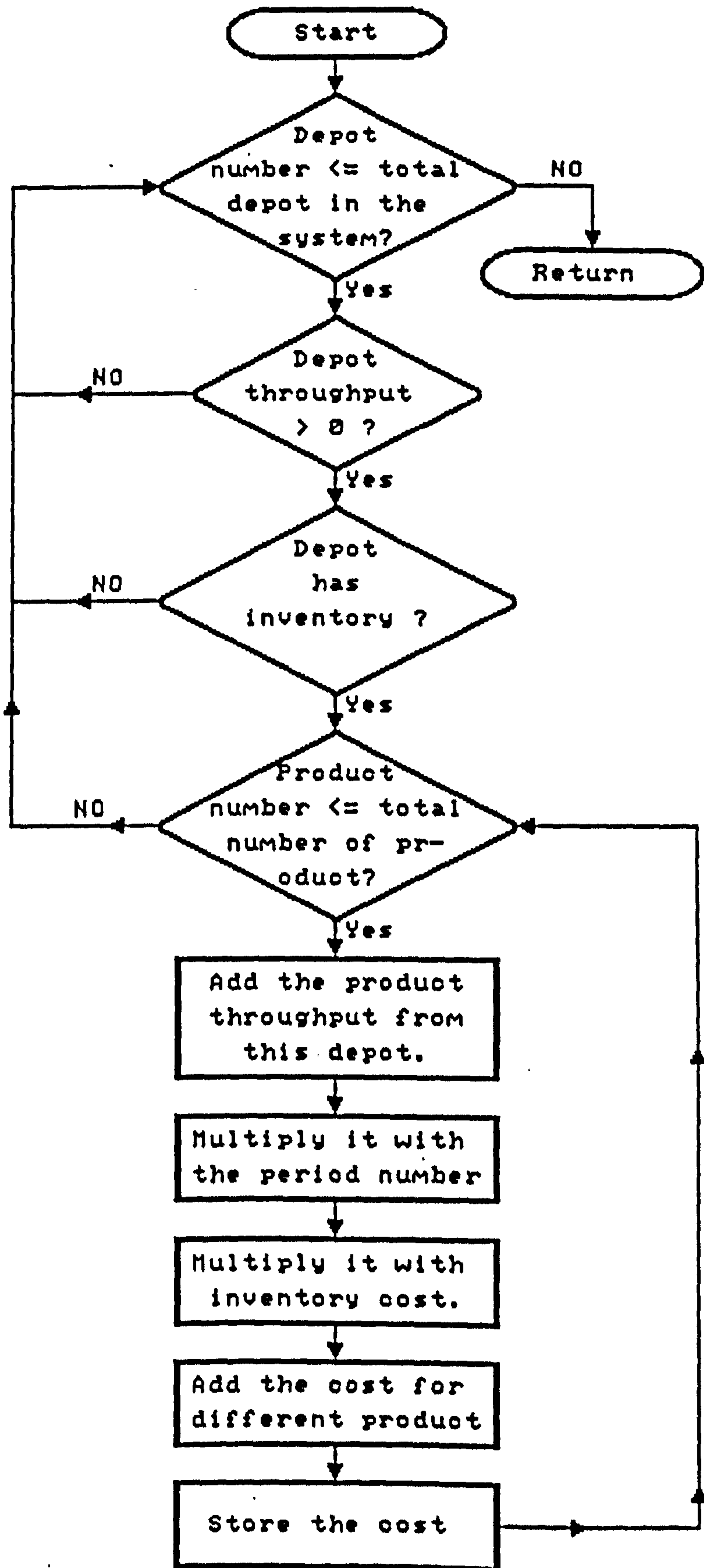

Figure 8.27 Subroutine Inocs

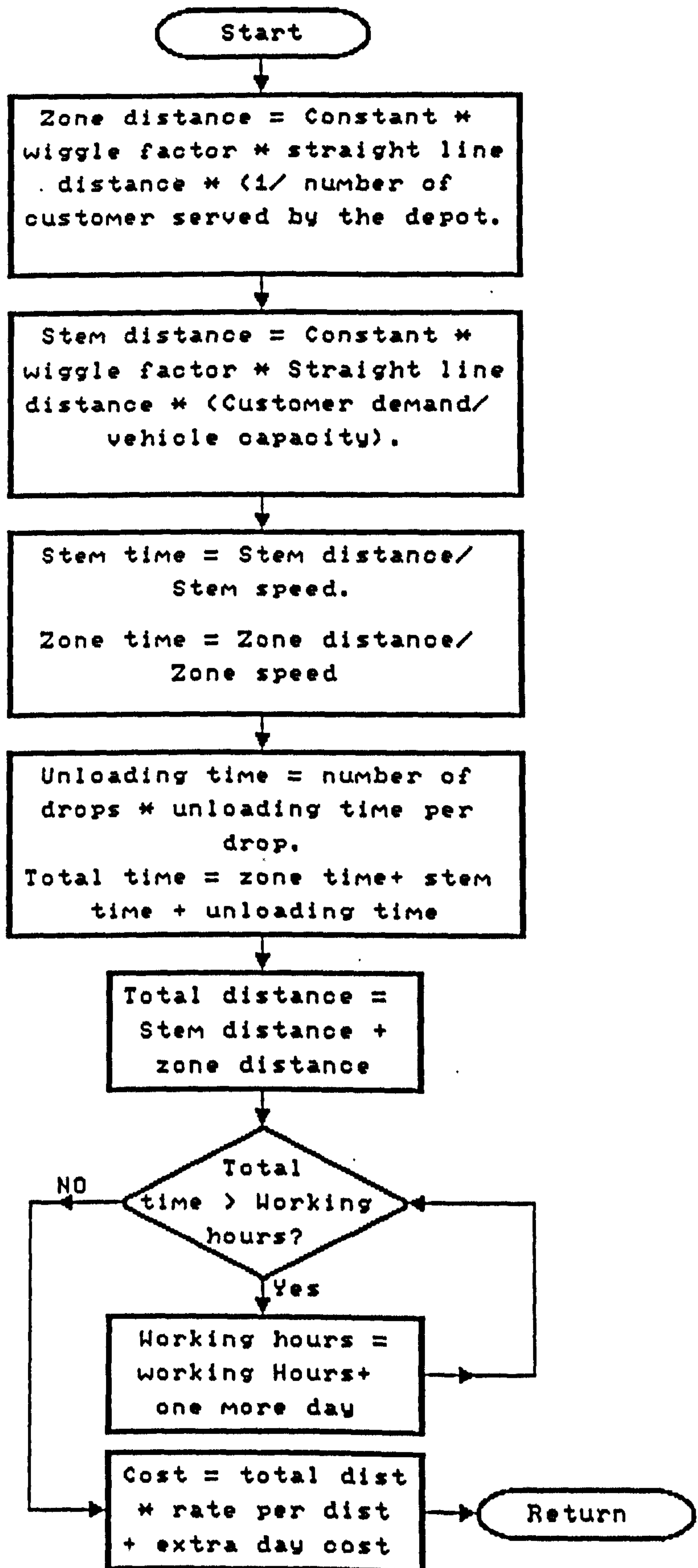

Figure 8.28 Subroutine Lodeco

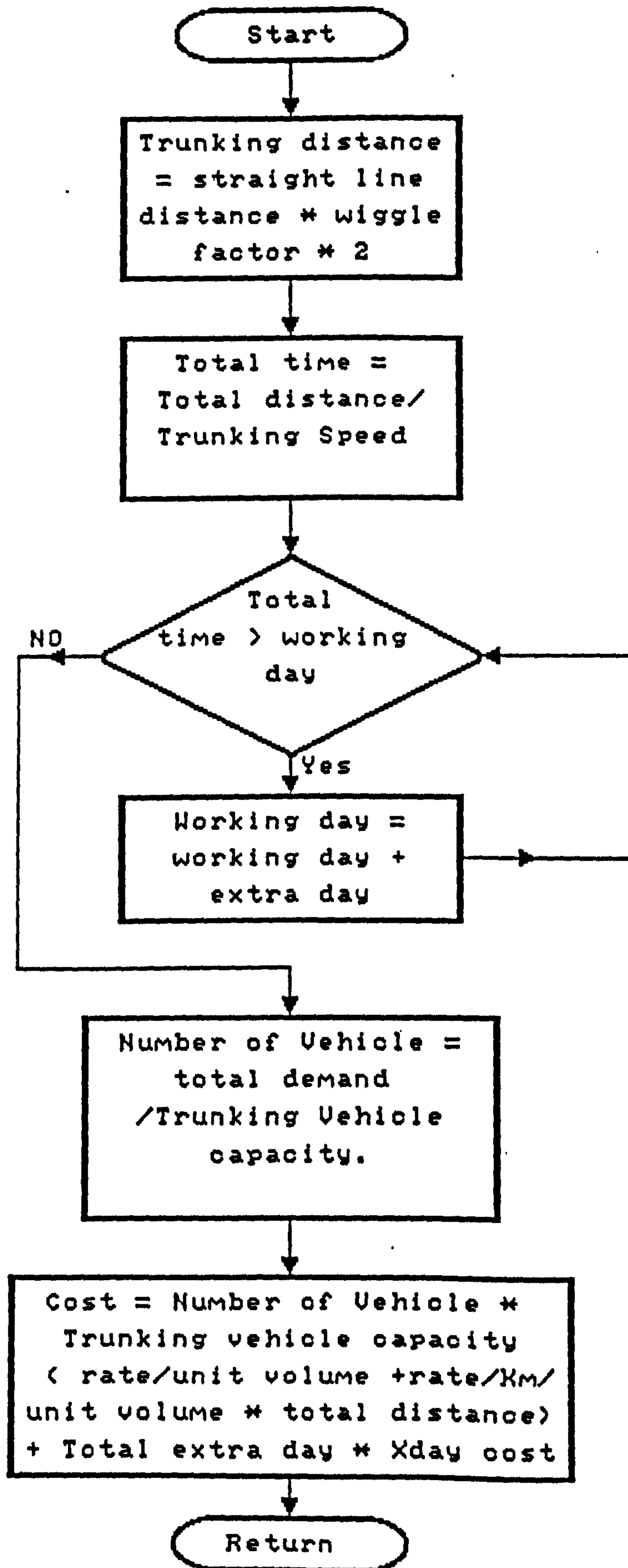

Figure 8.29
Subroutine TRDECO

8.4.4 ALOC1

Subroutine Aloc1 is used to display the menu on the screen. All the instructions are passed through this subroutine and return back to it. The data flow diagram is given in figure 8.30. The program also ends in this subroutine.

8.5 Optimisation

Optimisation is the name given to a search procedure to search for a best location for a depot. This is achieved by the following subroutine:

8.5.1 AUTLOC

Subroutine AUTLOC is used to search for the best possible location for all the depots in the system. The data flow diagram is given in figures 8.31, 8.31a and 8.31b. Before it optimises a depot it makes decision checks such as:

Is the depot located in the modelling area ?

Is the depot to be optimised ?

Does the depot have any throughput?

The subroutine uses three different steps to search for a best location. The value of step is defined as the distance of movement of depot from one place to the next in any direction (chapter six). It starts from the centre with largest jump and moves the depot into the four corners of a diamond shape, calculates the total cost (the cost from source point to this depot and from this depot to all those serving customers) at each location of depot, displays the depot location coordinate, and draws the lines between the depot and the customers, the depot to transshipment point it serves, and the depot to the source points from which it receives its material. It compares all of these costs and if the central cost is the least cost then it will reduce the step length. Otherwise it will make the least cost location a central location and repeat the process until the central cost location becomes the least cost location.

8-48

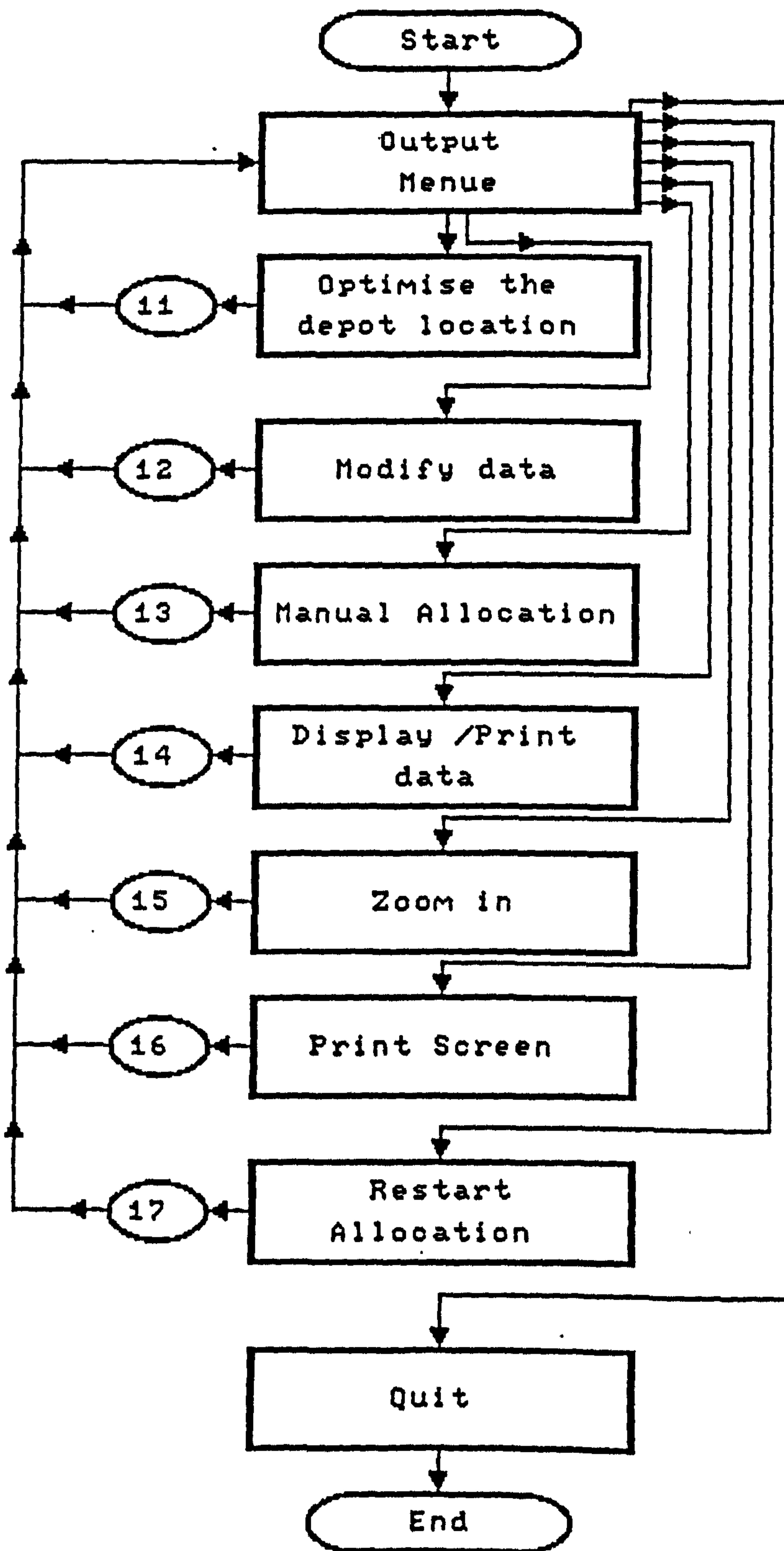

Figure 8.30

Subroutine ALOC1

8-49

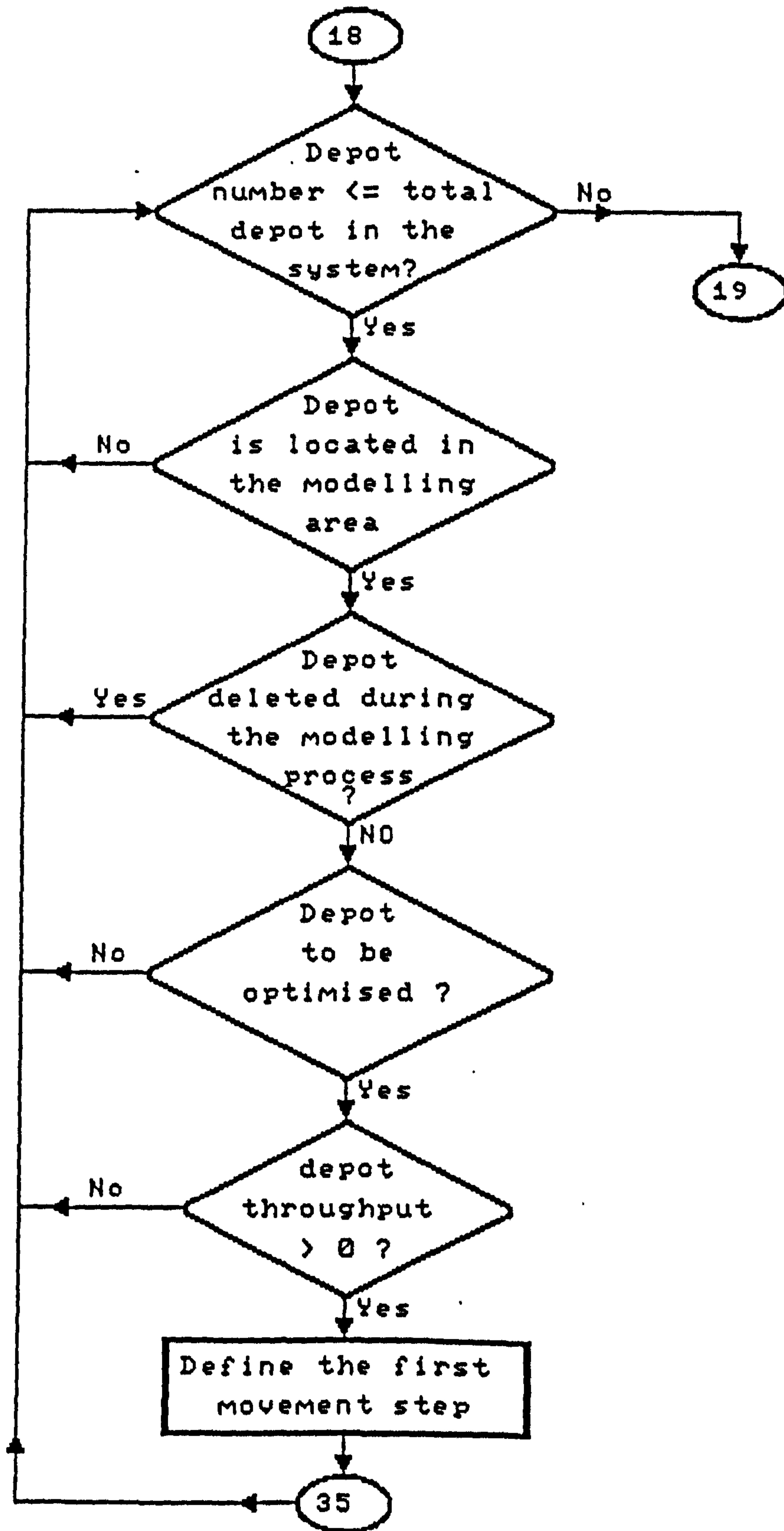

Figure 8.31

Subroutine AUTLOC

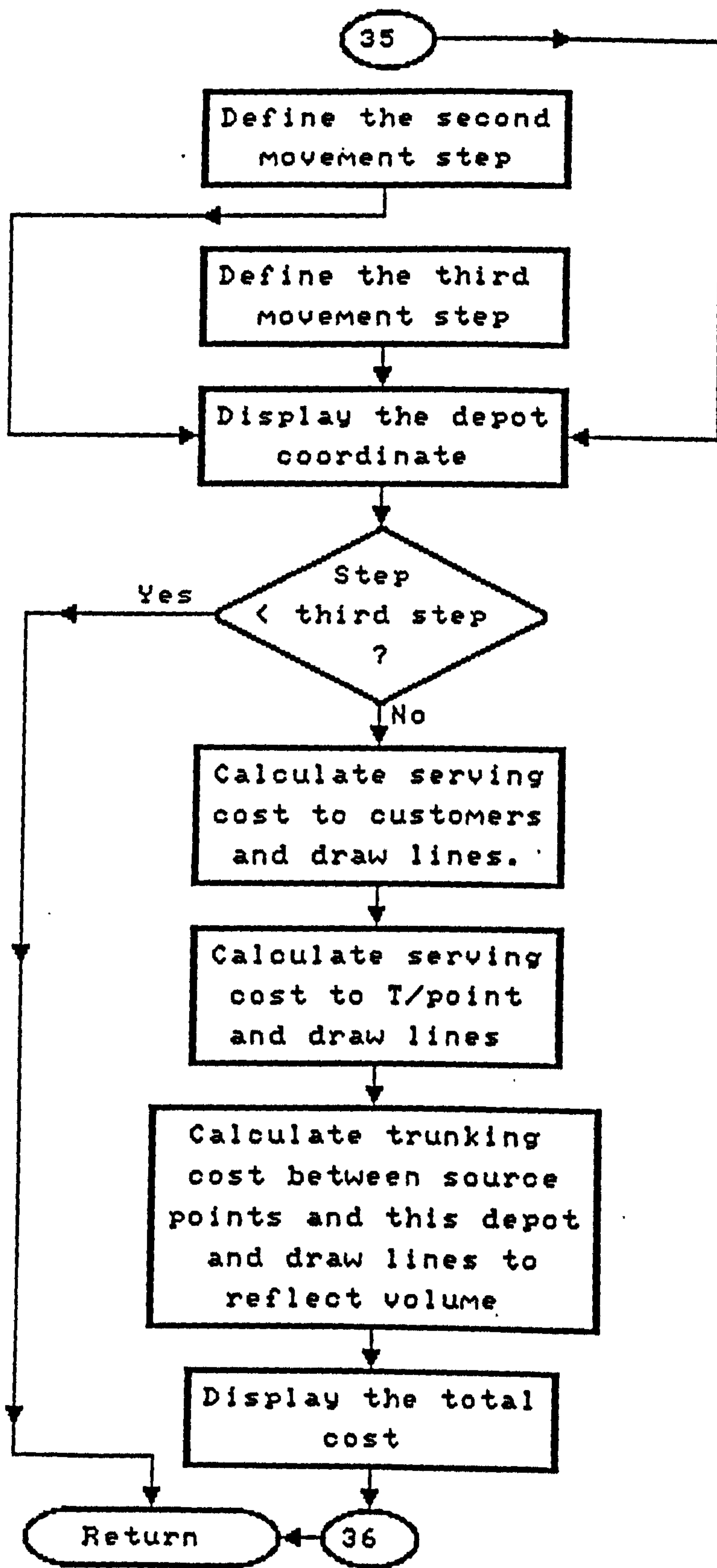

Figure 8.31a Subroutine AUTLOC

8-51

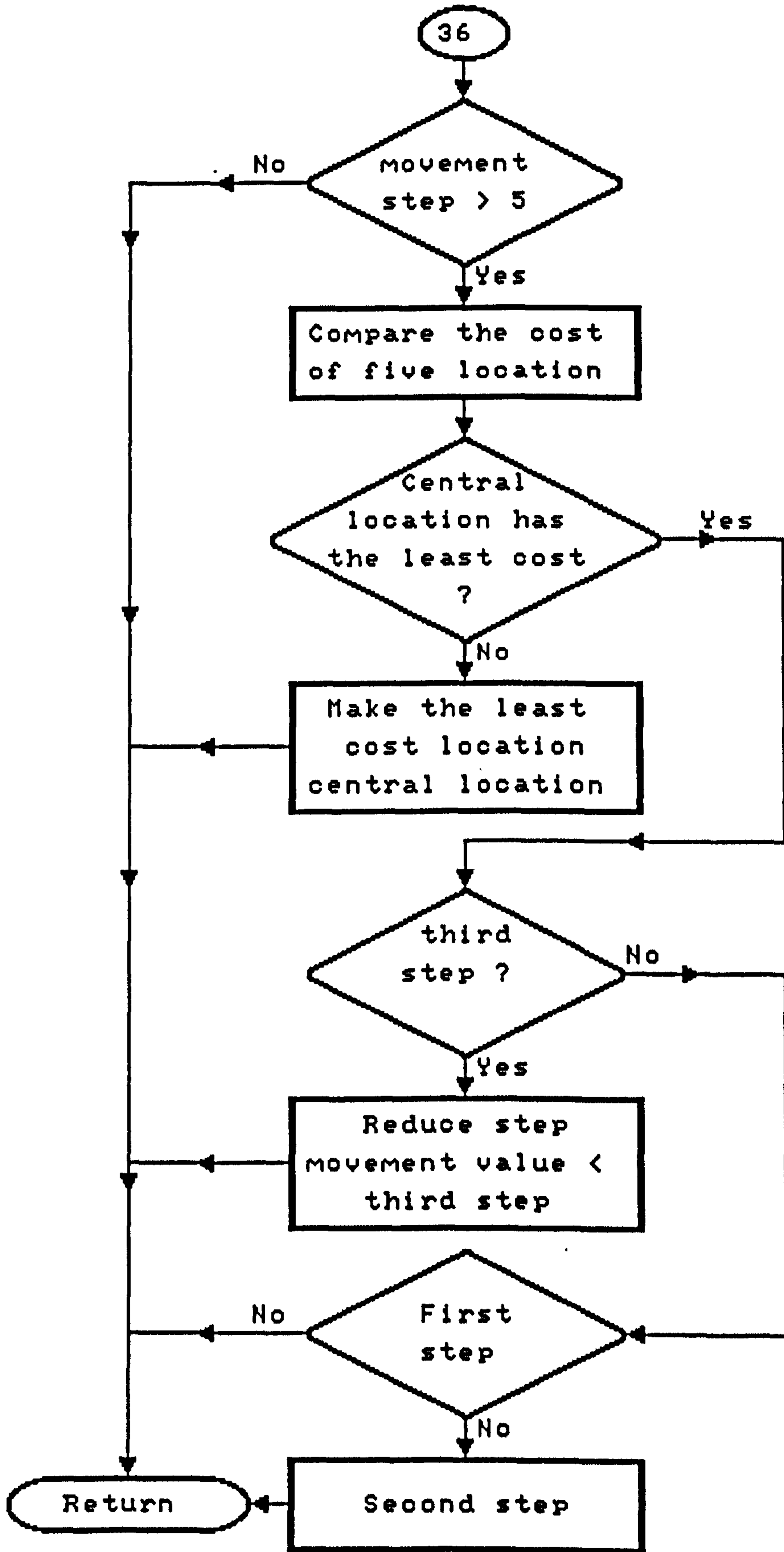

Figure 8.31b Subroutine AUTLOC

It will continue the above operation until it reaches the third step. On the third step, when it reaches a minimum cost location, this will be an optimum location for the depot.

The above procedure is repeated for all the distribution depots in the system.

8.5.2 AUTLO

This subroutine is used to find the best possible location for each transshipment point in the distribution system by using the above described technique. The only difference is that its source point is distribution depot, not the production place. The data flow diagrams are given in figures 8.32, 8.32a and 8.32b.

8.6 MODIFY

This subroutine is used to allow modifications to be made visually and interactively in the program. The data flow diagram is given in figure 8.33.

8.6.1 CNPL

Subroutine CNPL is used to select the option of adding, deleting and moving source points (factories). It is also used to add a source point into the logistics system. The data flow diagram is given in figure 8.34.

When a factory is being added to the system, this subroutine checks the existing number of factories. If they add up to ten, this is the maximum number LSM is able to manage, the program will not add another factory to the system. If the total is less than ten, the program will display the cursor on the screen. The cursor can be moved to the factory location position and the position confirmed by the carriage return. This program also reads the name, production capacity, product factory produce and inventory cost for this product in a modelling period.

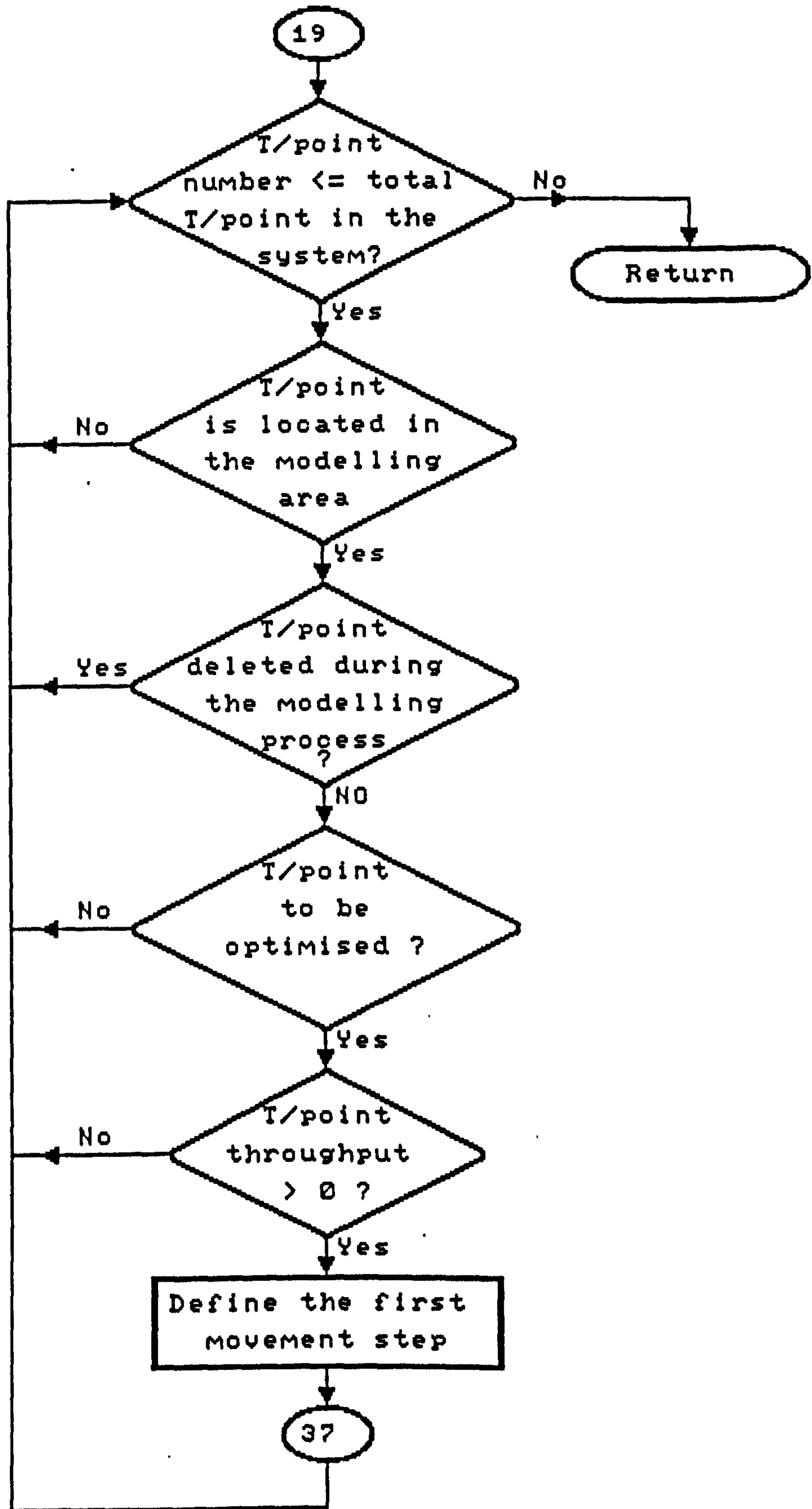

Figure 8.32 Subroutine AUTLO

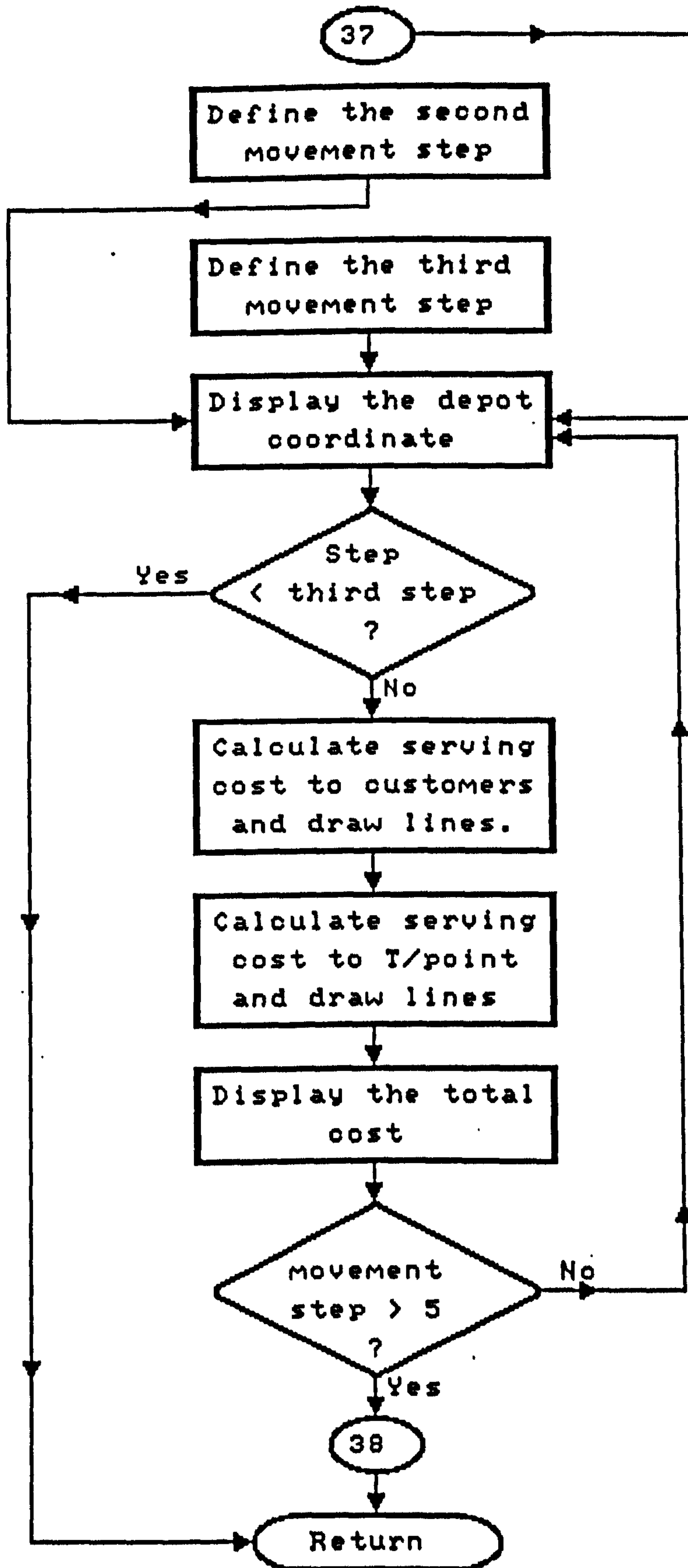

Figure 8.32a Subroutine AUTLO

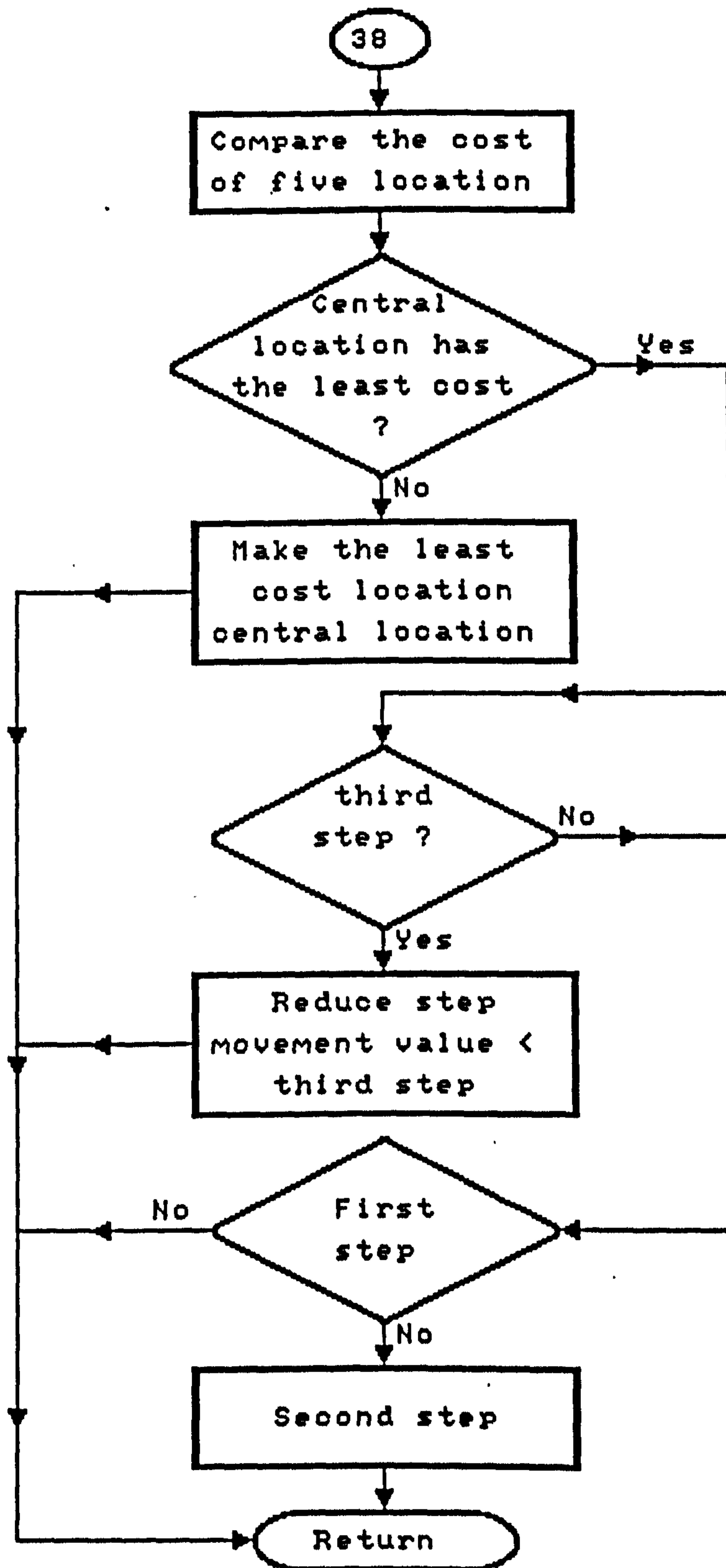

Figure 8.32b Subroutine AUTLO

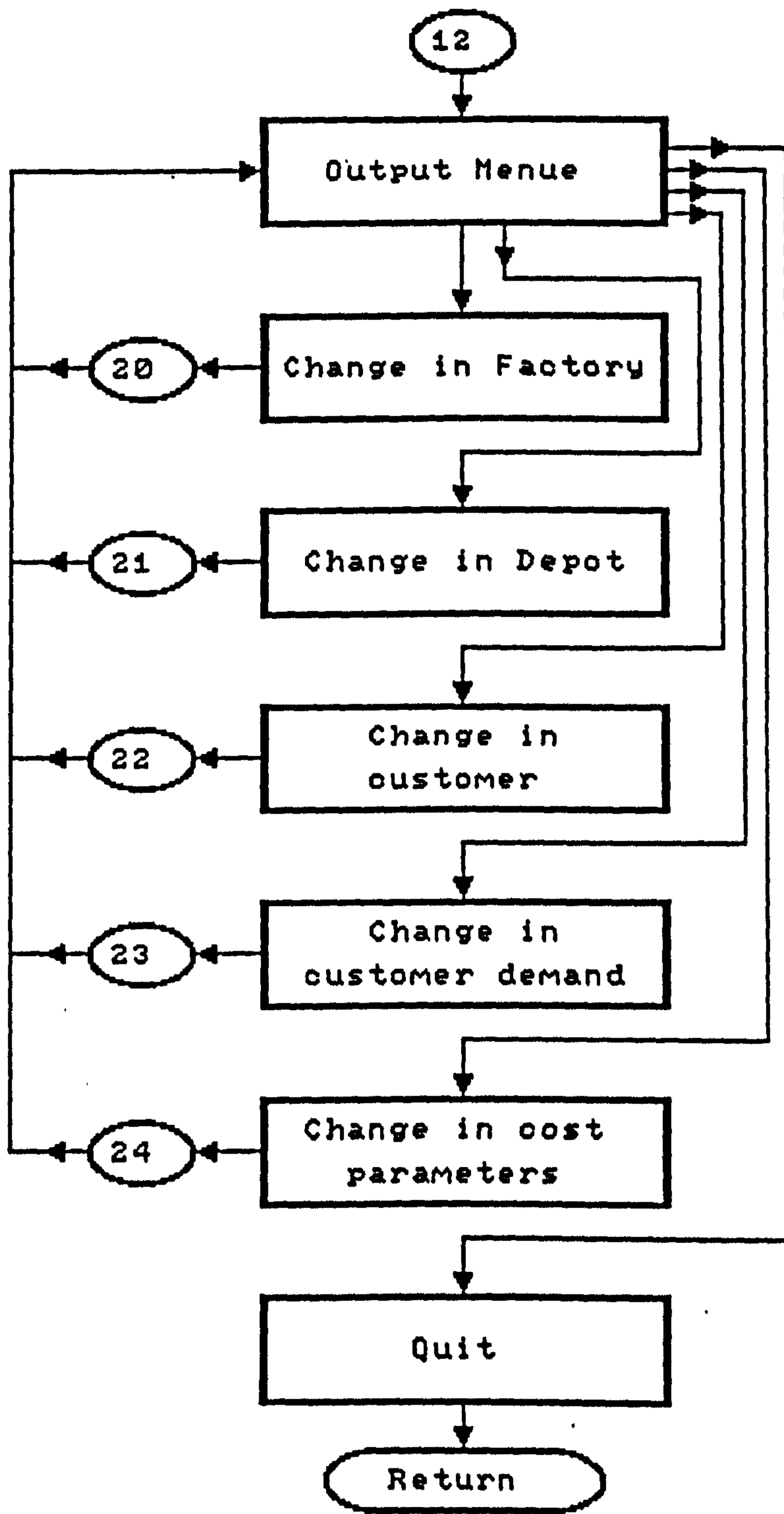

Figure 8.33 Subroutine MODIFY

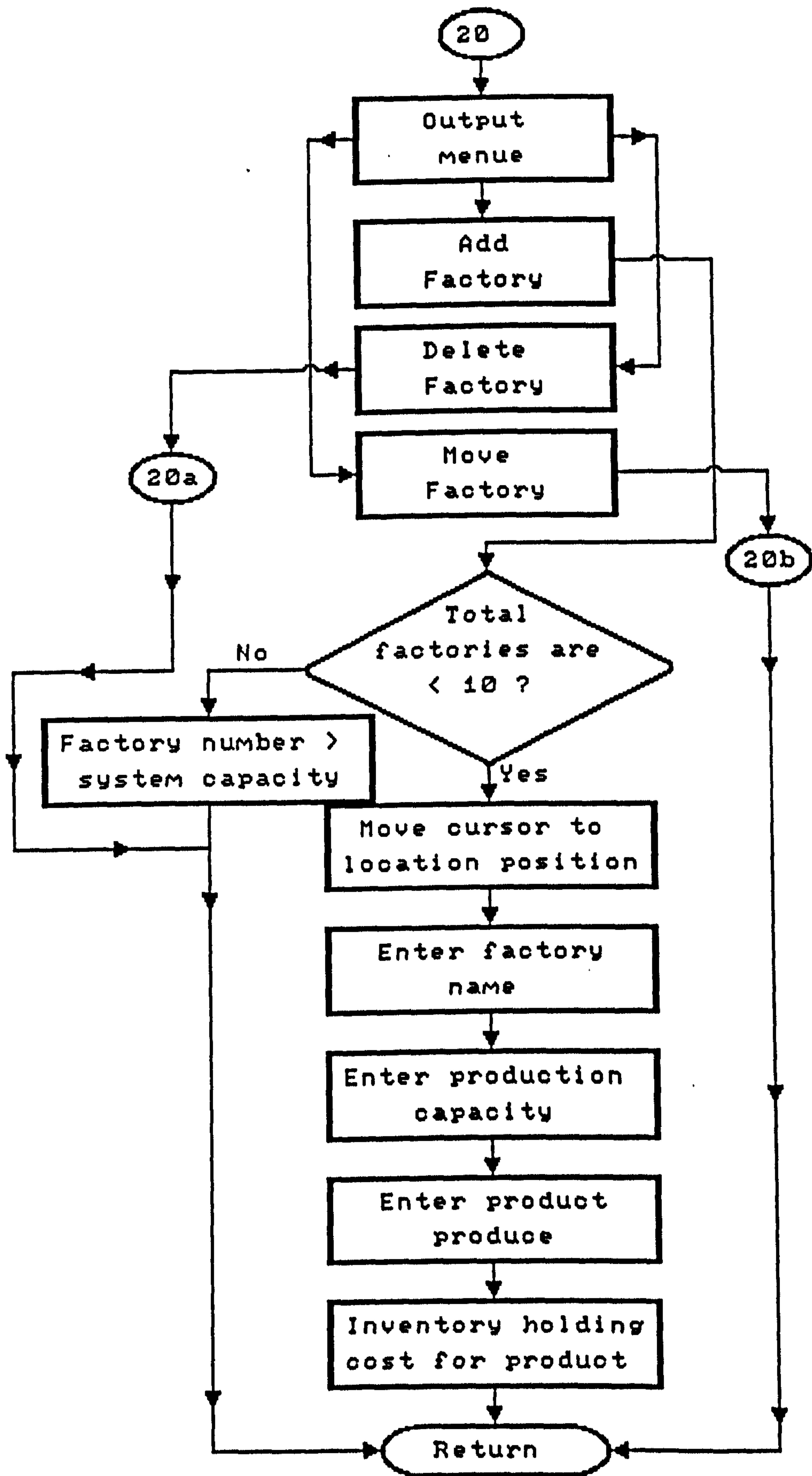

Figure 8.34 Subroutine CNPL

8.6.2 CNPL2

Subroutine CNPL2 is used to delete a factory from the system. The data flow diagram is given in figure 8.34a.

To delete a factory, the cursor is moved on to a factory. This subroutine will go through search and check that any factory is located at the cursor position. If the factory is located at the cursor position then it will remove the factory from the system. Otherwise it will display "Factory not found - Quit or Continue?". On Continue it will repeat the same process again. On quitting it will go out of CNPL2.

8.6.3 CNPL3

Subroutine CNPL3 is used to move a factory from one place to another. The data flow diagram is given in figure 8.34b.

CNPL3 checks that the factory is located in the cursor position. If it is, it will delete the factory from this position and move it to the required position. If no factory is located in the cursor position then it will display "Factory not found - Quit or Continue?". On Quit, it will go out of CNPL3. On Continue it will repeat the above process.

The subroutines CNDIS, CNDIS2 and CNDIS3 performs the identical operation as described above for depots and CCNU, CCNU2 and CCNU3 repeat above procedure for customers. The data flow diagram for CNDIS is given in figure 8.35, for CNDIS2 is given in figure 8.35a and for CNDIS2 is given in figure 8.35b. The data flow diagrams for CCNU is given in 8.36, CCNU2 is given in 8.36a and CCNU3 is given in 8.36b.

8.6.4 FOCAS

As described in chapter seven, LSM is able to increase or decrease the demand by:

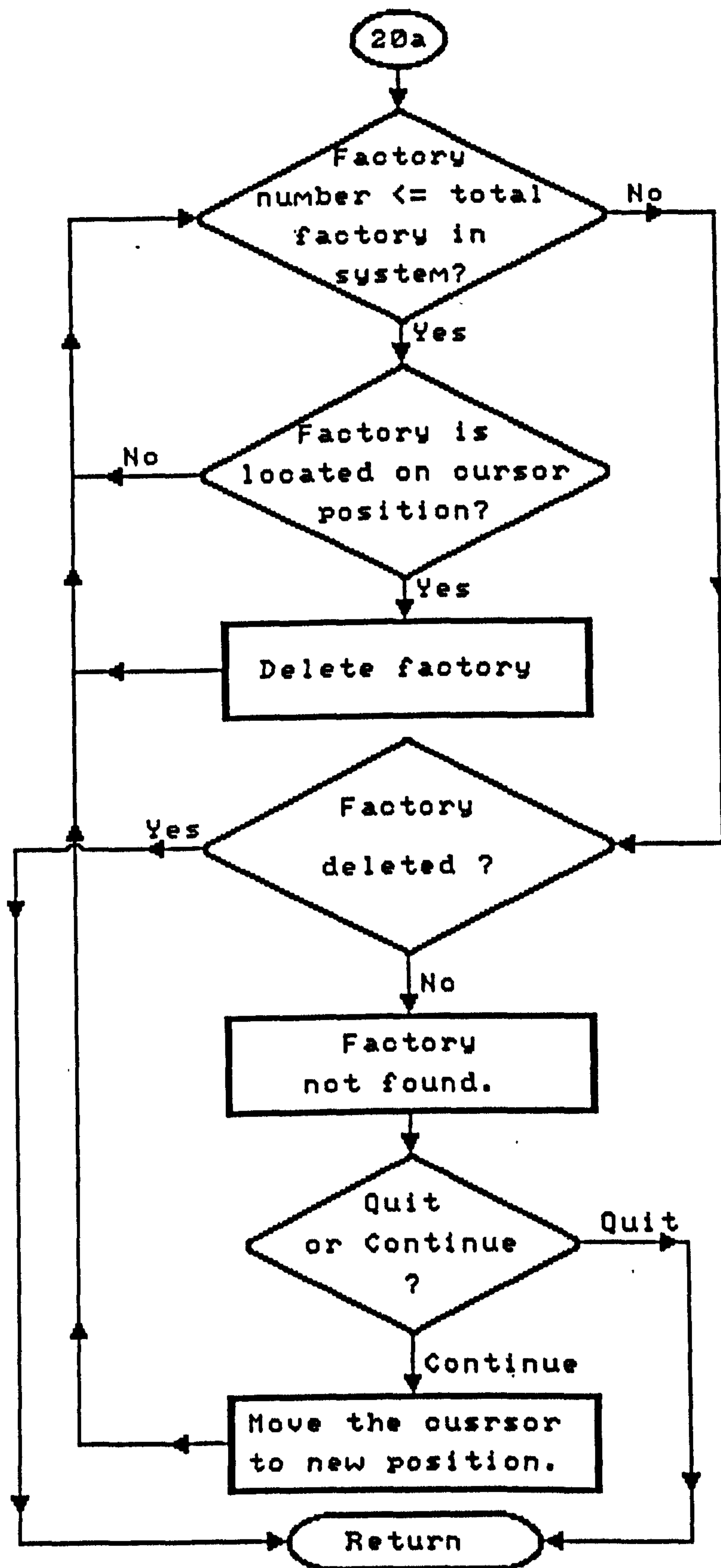

Figure 8.34a Subroutine CNPL2

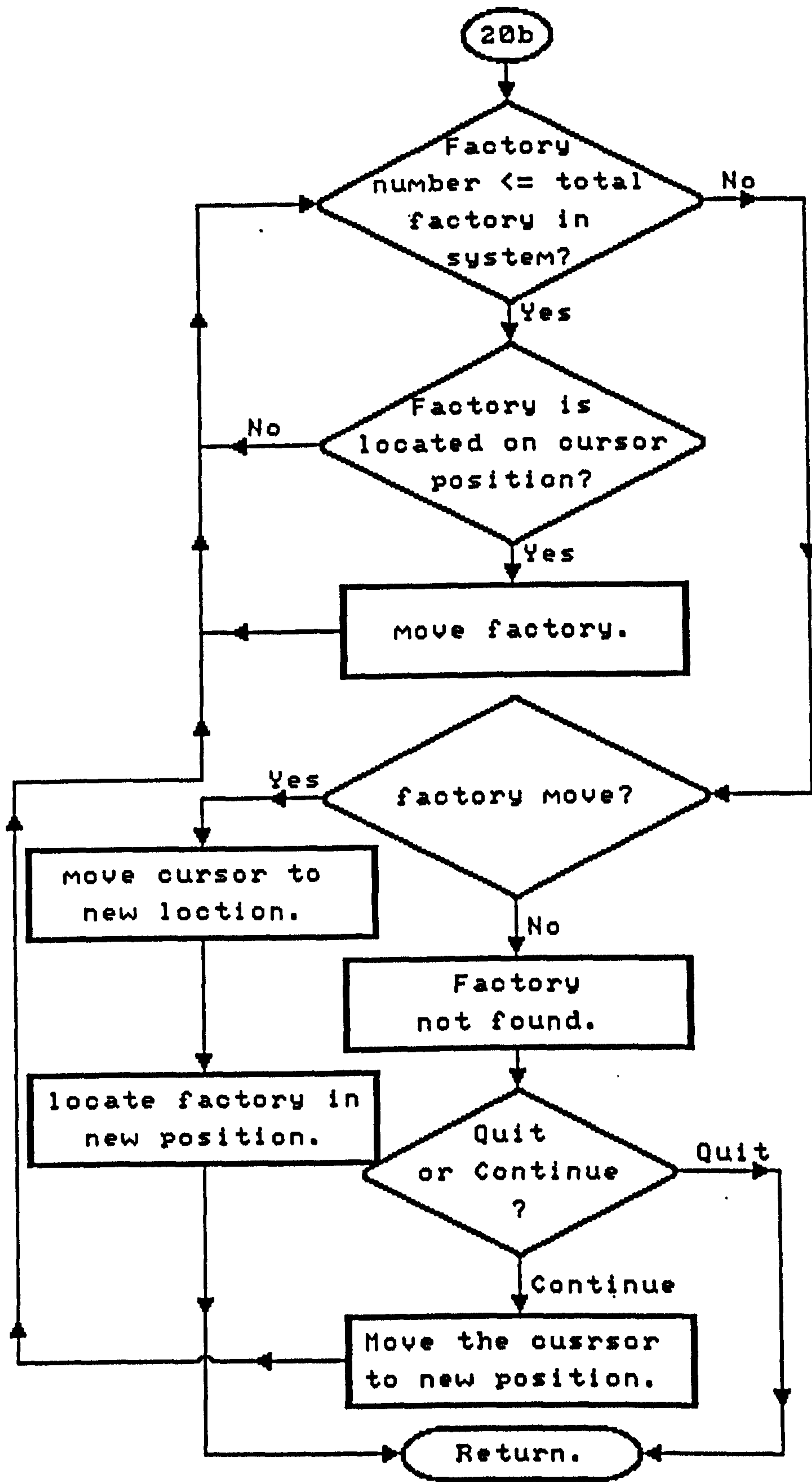

Figure 8.34b Subroutine CNPL3

8-61

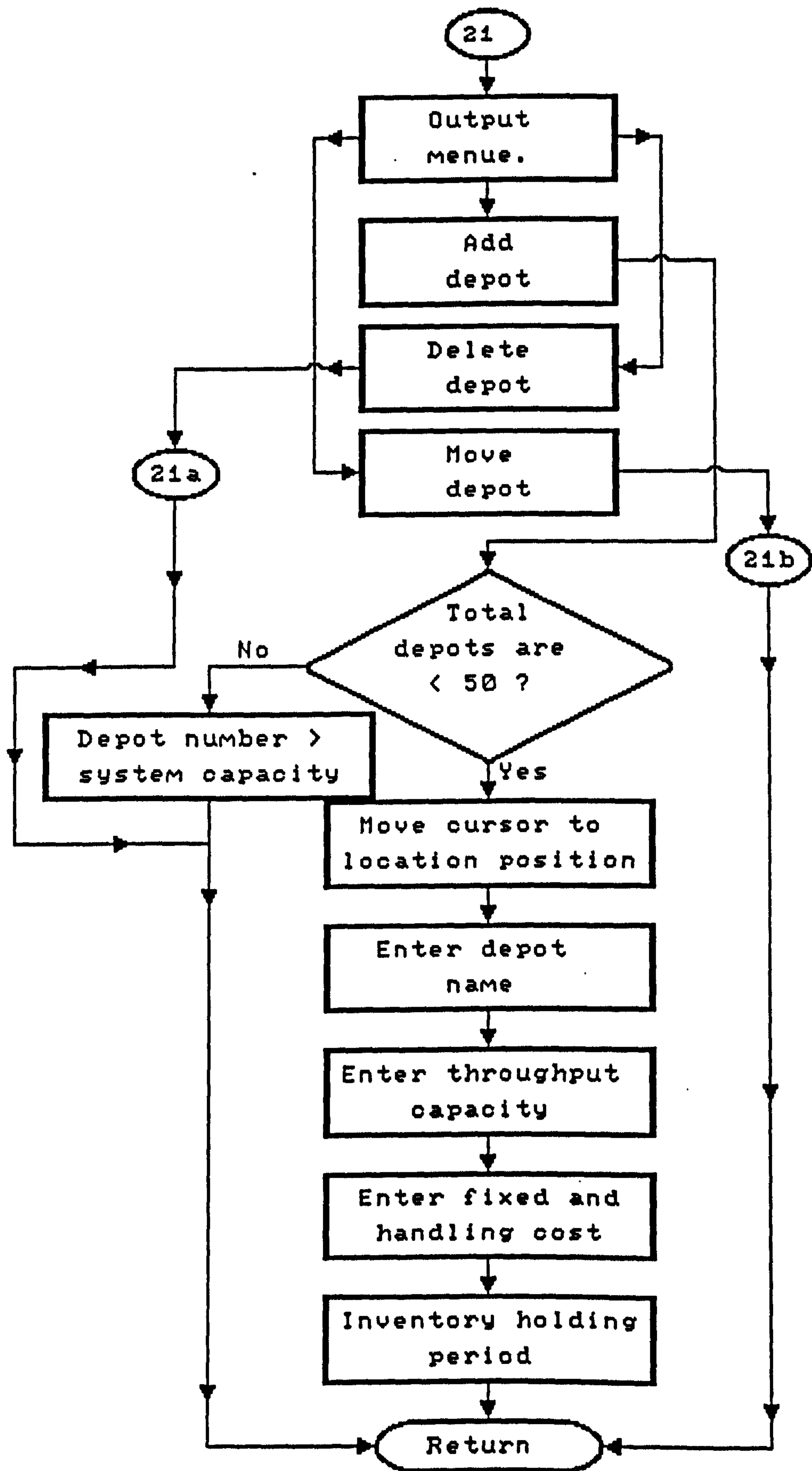

Figure 8.35 Subroutine CNDIS

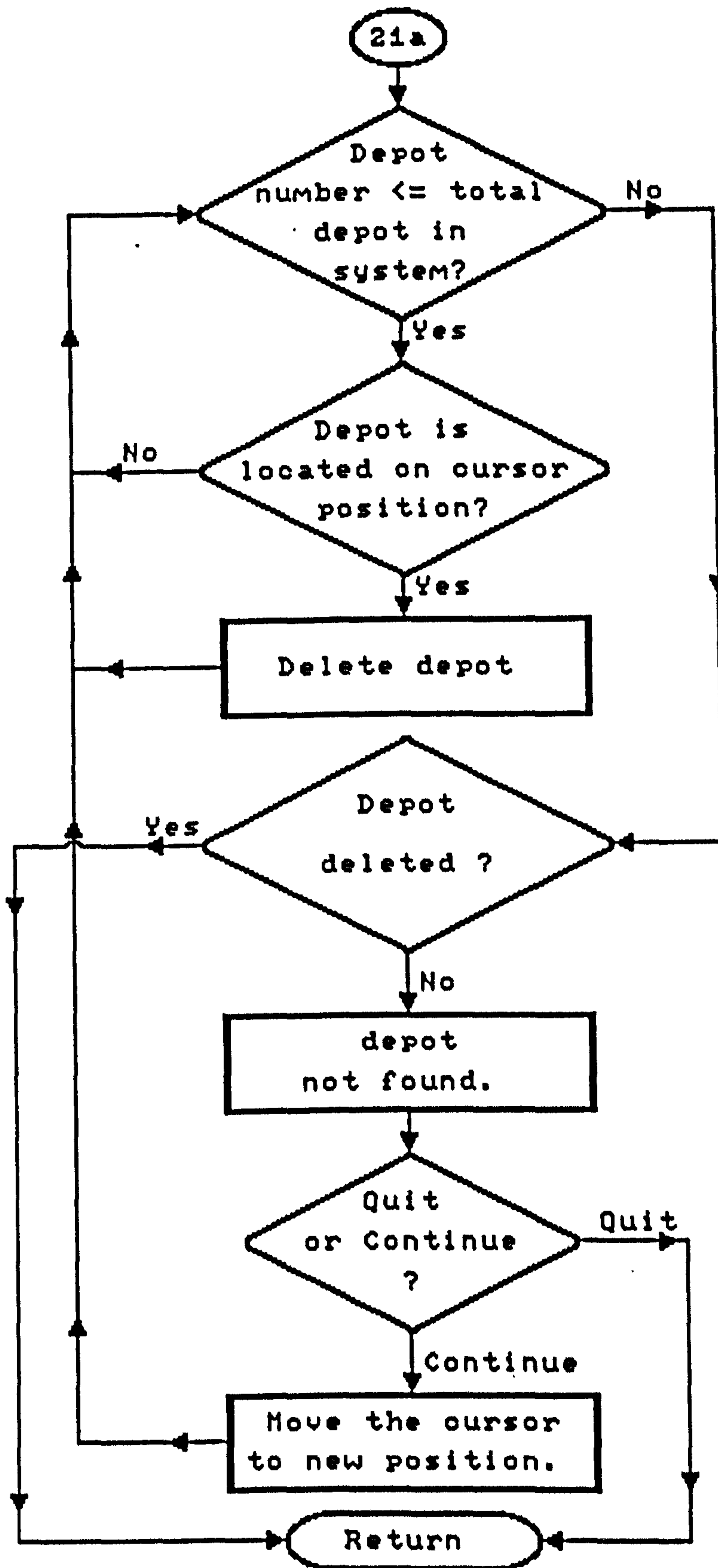

Figure 8.35a Subroutine CNDIS2

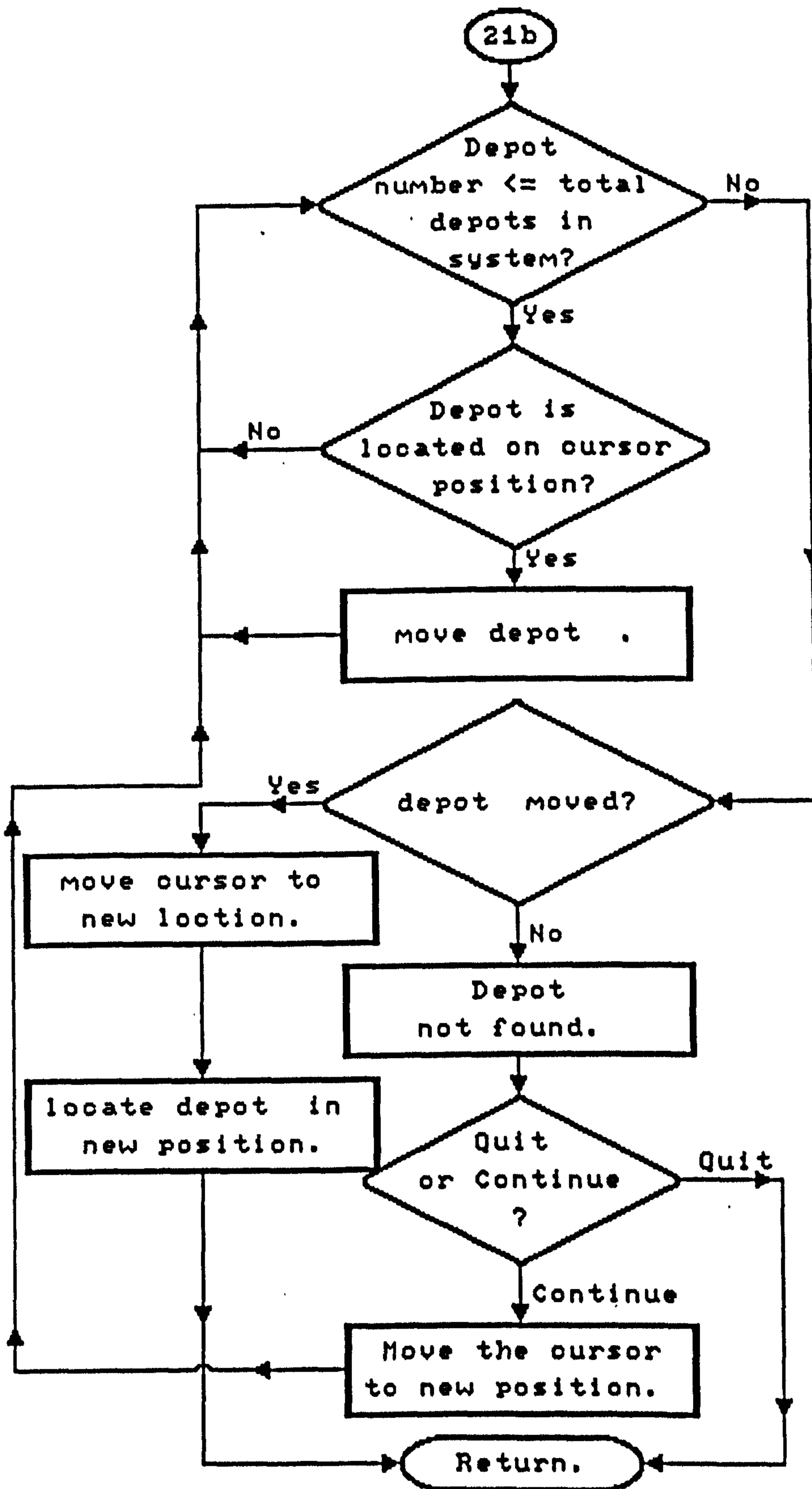

Figure 8.35b Subroutine CNDIS3

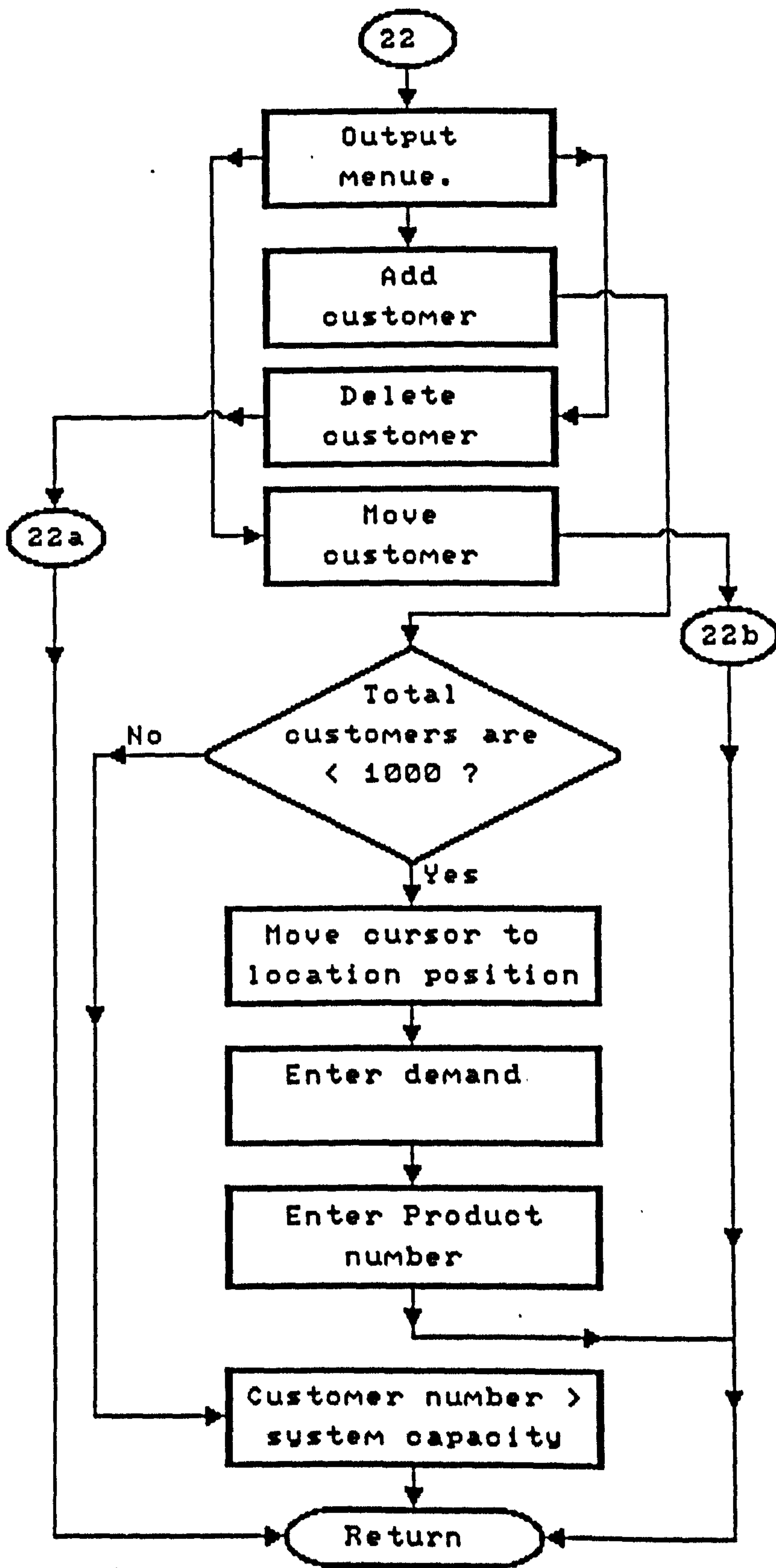

Figure 8.36 Subroutine CCNU

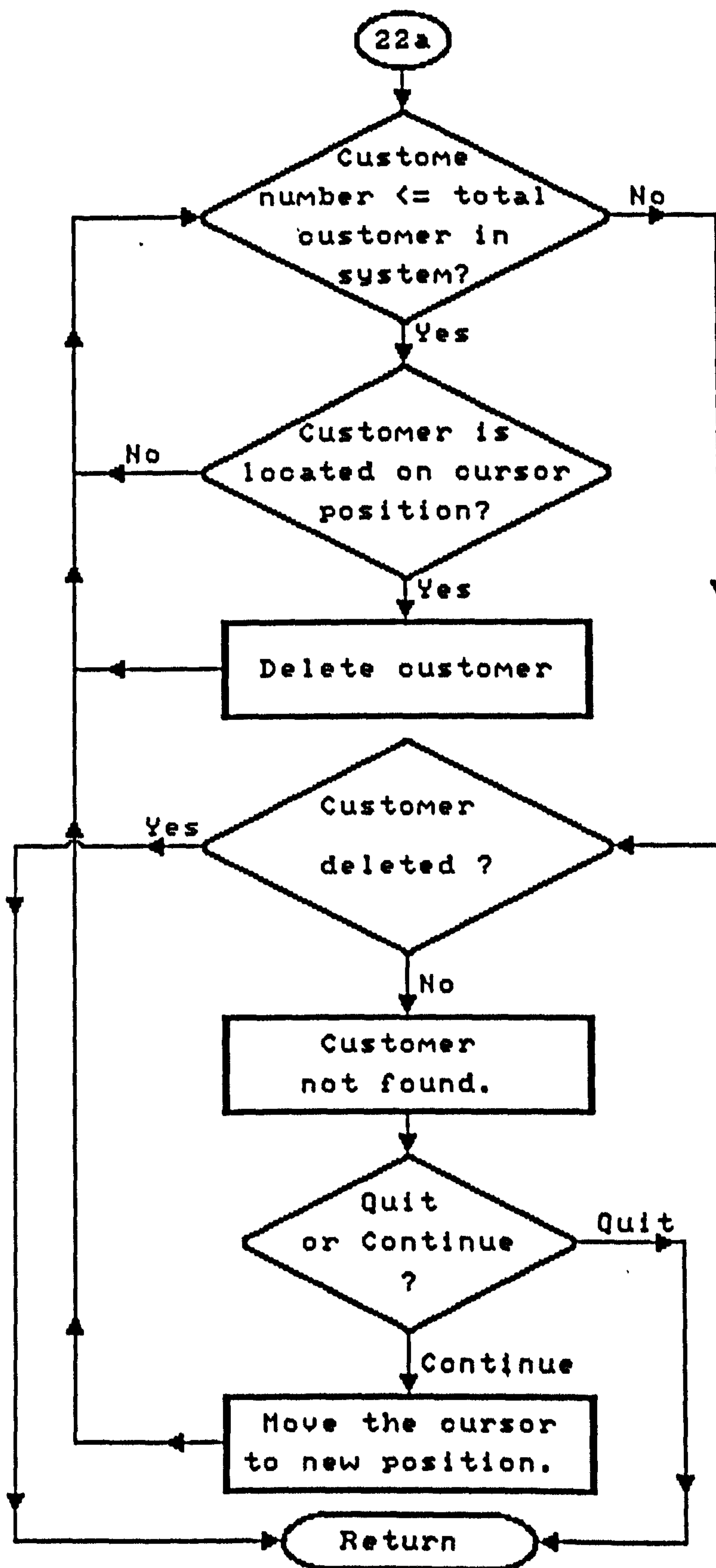

Figure 8.36a Subroutine CCNU2

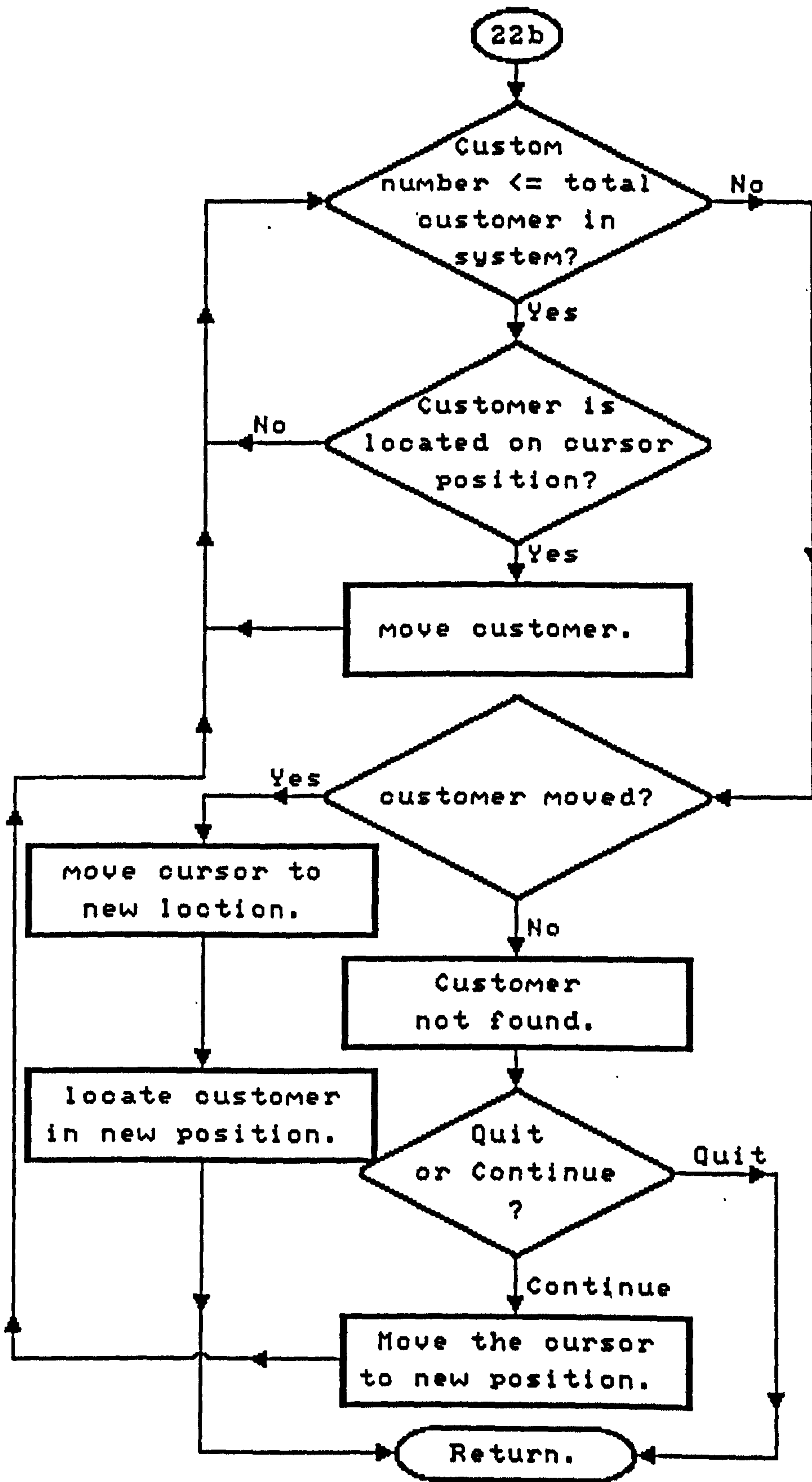

Figure 8.36b Subroutine CCNU3

Product base; by using this function, the demand for each product in the system can be increased or decreased individually. For example product number demands may increase 10 percent but product number two demand may decrease 5 percent. Product based forecasting is able to deal with this situation.

Area base; by using this function, LSM can increase or decrease the demand of an particular area. For example if demand of all the customers in the London area (which need to be defined by window on the screen) goes up by 15 percent but the demand for customers in Scotland is reduced by 5 percent, the area function is used.

All the customers; By using this function LSM increases or decreases the demand of all the customers in the modelling system.

Subroutine FOCAST is used to display the menu for increasing the demand by product, area and all the customers. The data flow diagram is given in figure 8.37. This subroutine is also used to increase the demand for all the customers in the modelling system. It multiplies customer demand with the forecasting factor.

8.6.5 FOCAST1

Subroutine FOCAST1 is used to increase the customer demand on a regional basis. The data flow diagram is given in figure 8.37a. If any area has been used to increase the demand previously, the subroutine will display on the screen the map and highlighted area.

When an area is used to increase the demand, the program will check that a customer is located in the highlighted area. If one is, then it will multiply the his by the forecasting factor.

8.6.6 FOCAST2

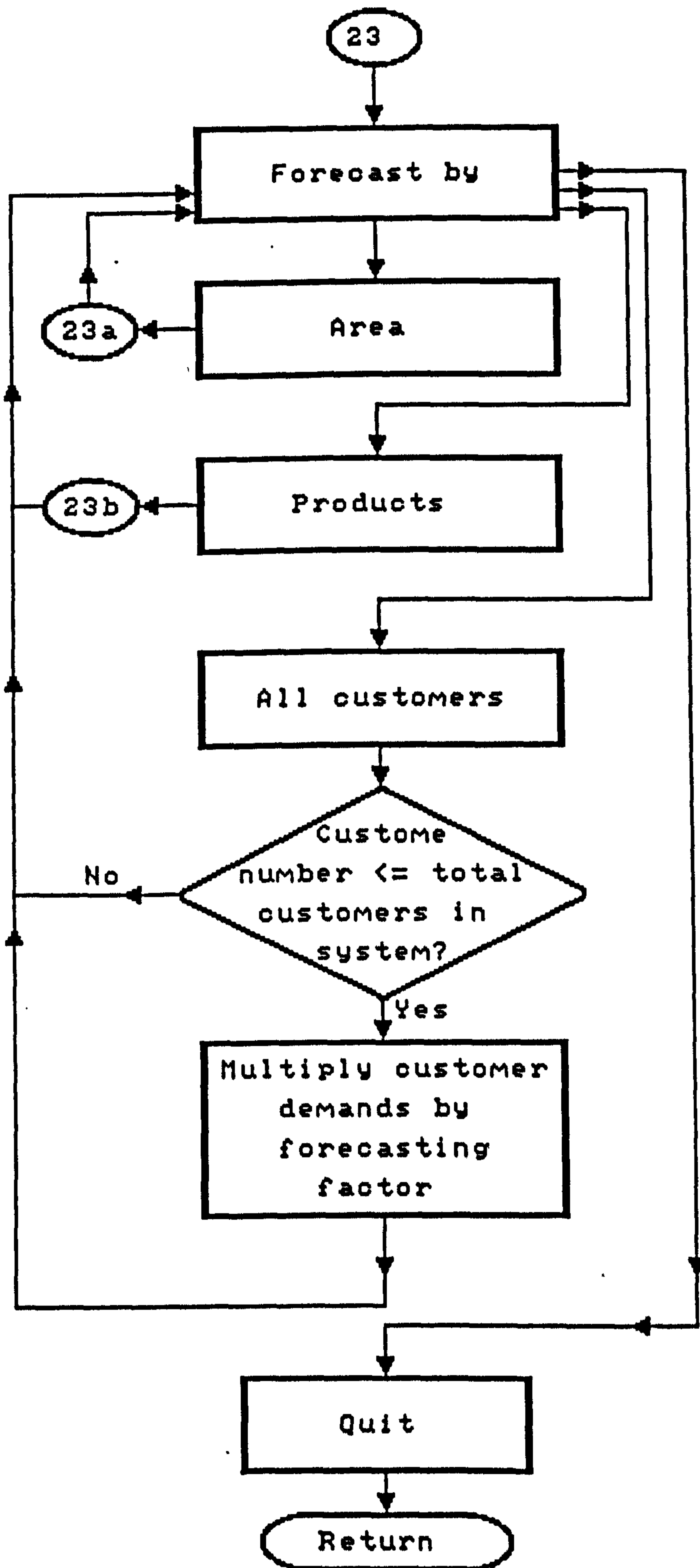

Figure 8.37 Subroutine FOCAST

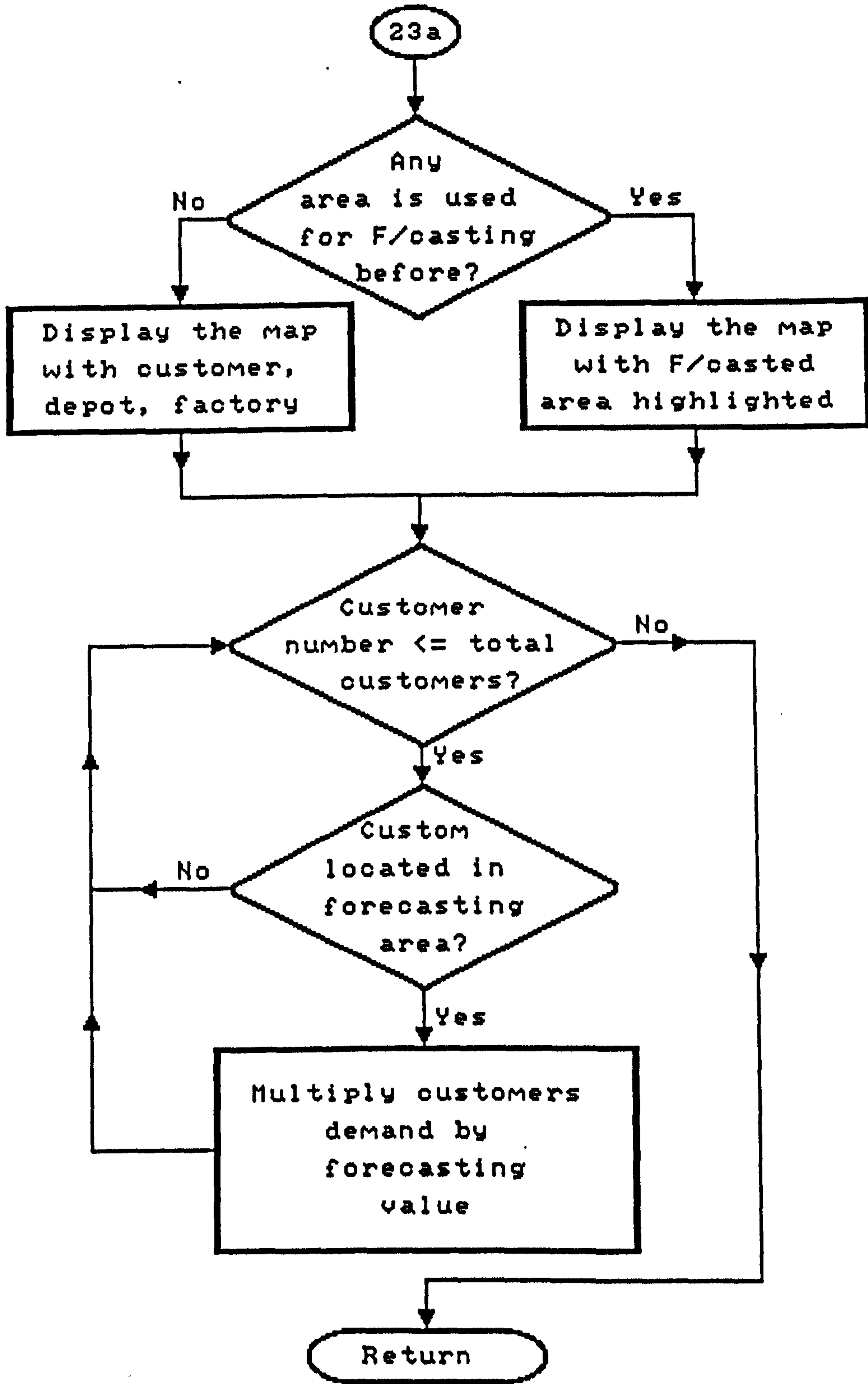

Figure 8.37a Subroutine F0CAST1

Subroutine FOCAS2 is used to increase the demand by product number. The data flow diagram is given in figure 8.37b. For each product, the subroutine will check that the customer has the same product number as the product being forecast. If the number of product is same then the demand will be multiplied by forecasting factor.

8.7 MAN1

Subroutine MAN1 is used to display the menu for manual allocation of customers to depot or transshipment points, transshipment points to depots and depots to source points (factory). The data flow diagram is given in figure 8.38.

8.7.1 MANAL1

Subroutine MANAL1 is used to allocate a customer to a depot or transshipment point. The data flow diagrams are given in figures 8.38a and 8.38b. The cursor is moved to the location of a customer. The subroutine makes a do loop search to check if a customer is located at the cursor position. If one is, the cursor is moved to a particular depot or transshipment point, to which the customer will be allocated. After positioning the cursor at the required position, MANAL1 will make a loop search to check the location position. If the depot or transshipment point is located at the position then it will display the cost of allocation and draw the line between the two. However if a customer or depot or transshipment point is not located at the cursor position, then it will display " not found, Quit or Continue?" If quit is activated then it will go out of MANAL1. If continue is stated then the subroutine will repeat one of the above processes.

The data flow diagrams for the subroutine MANAL2 are given in figure 8.38c and 8.38d. This subroutine performs the above procedure for transshipment points and distribution depots.

The data flow diagrams for the subroutine MANAL3 is given in figure 8.38e

8-71

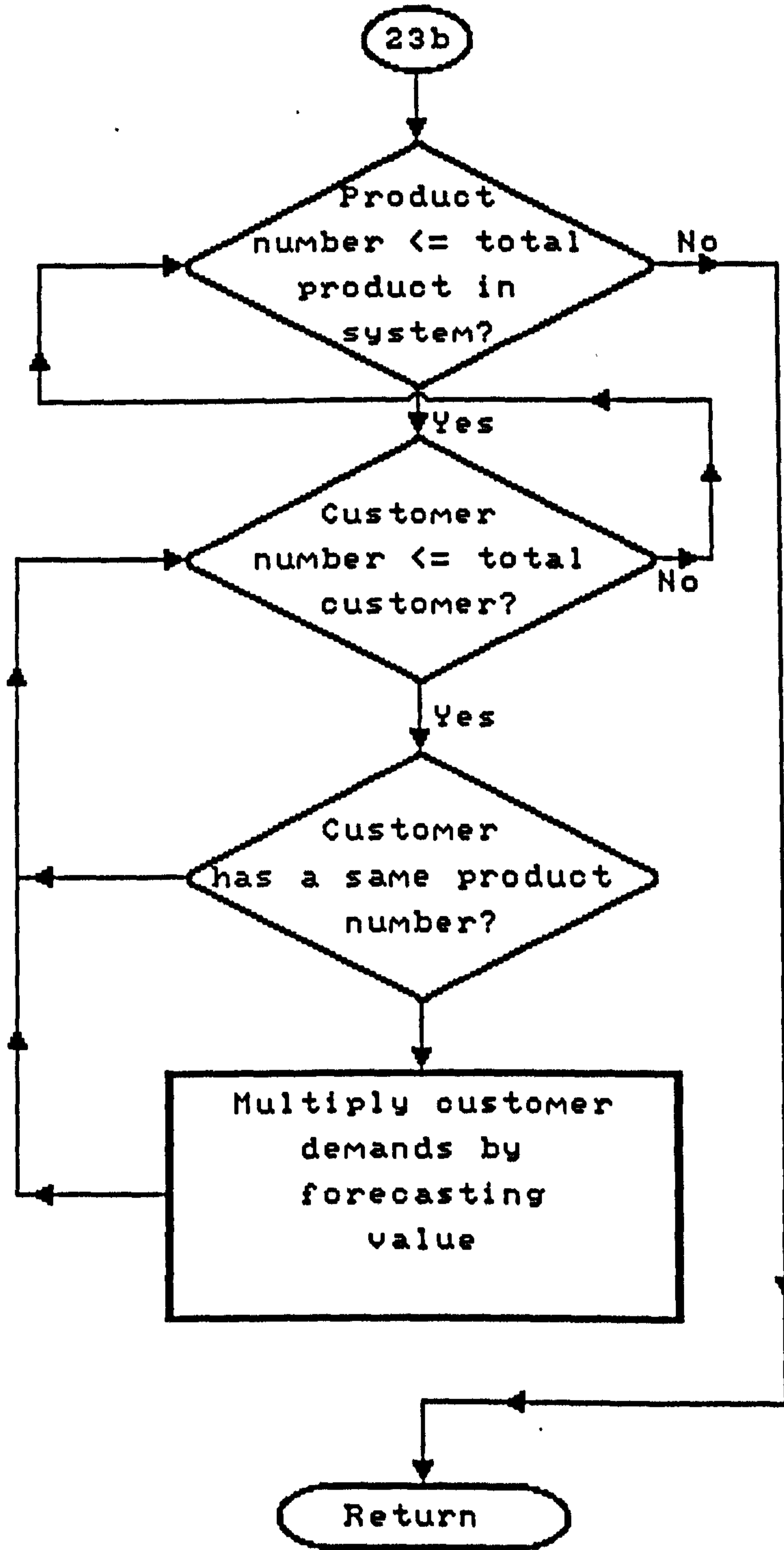

Figure 9.37b Subroutine FOCAS12

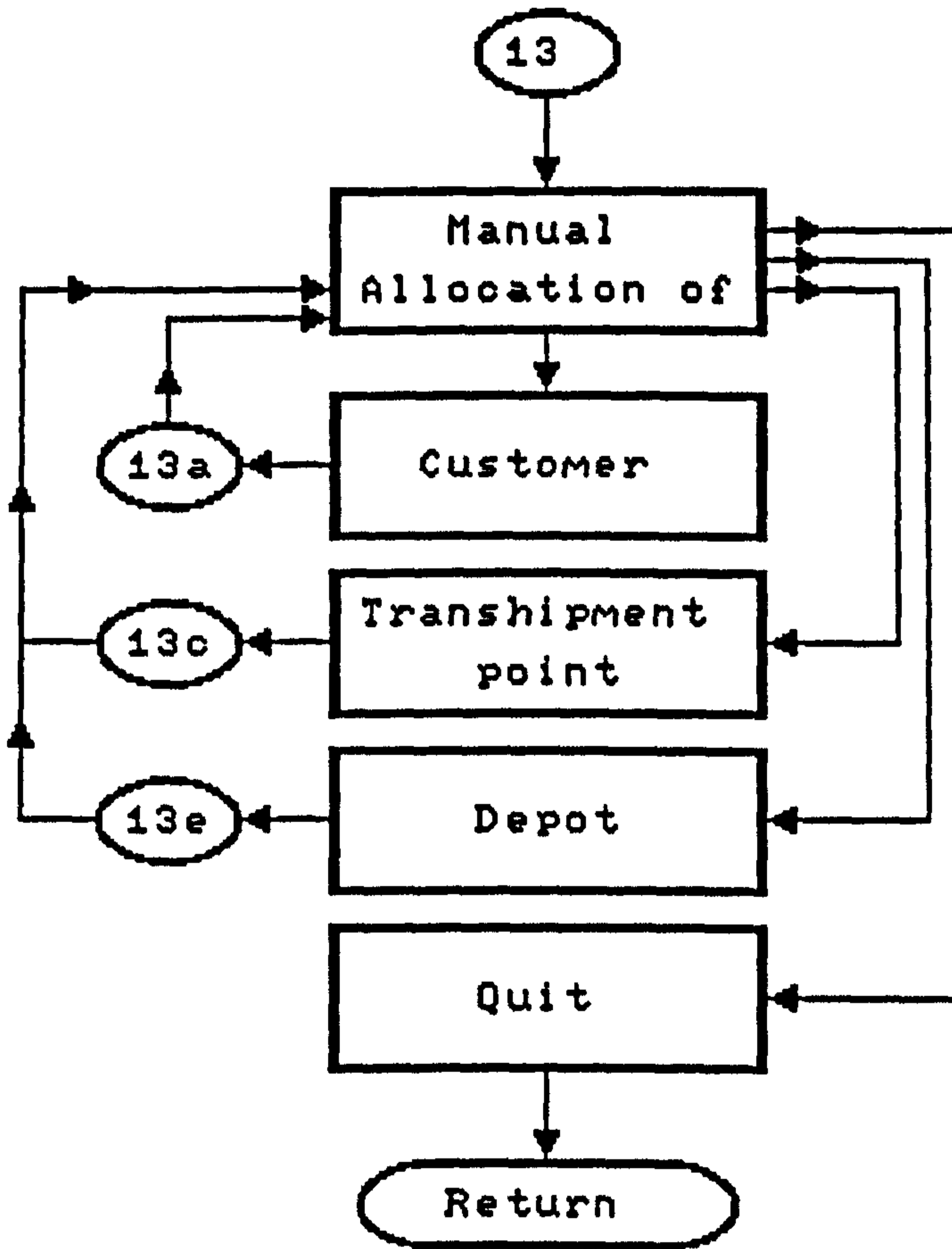

Figure 8.38 Subroutine MAN1

8-73

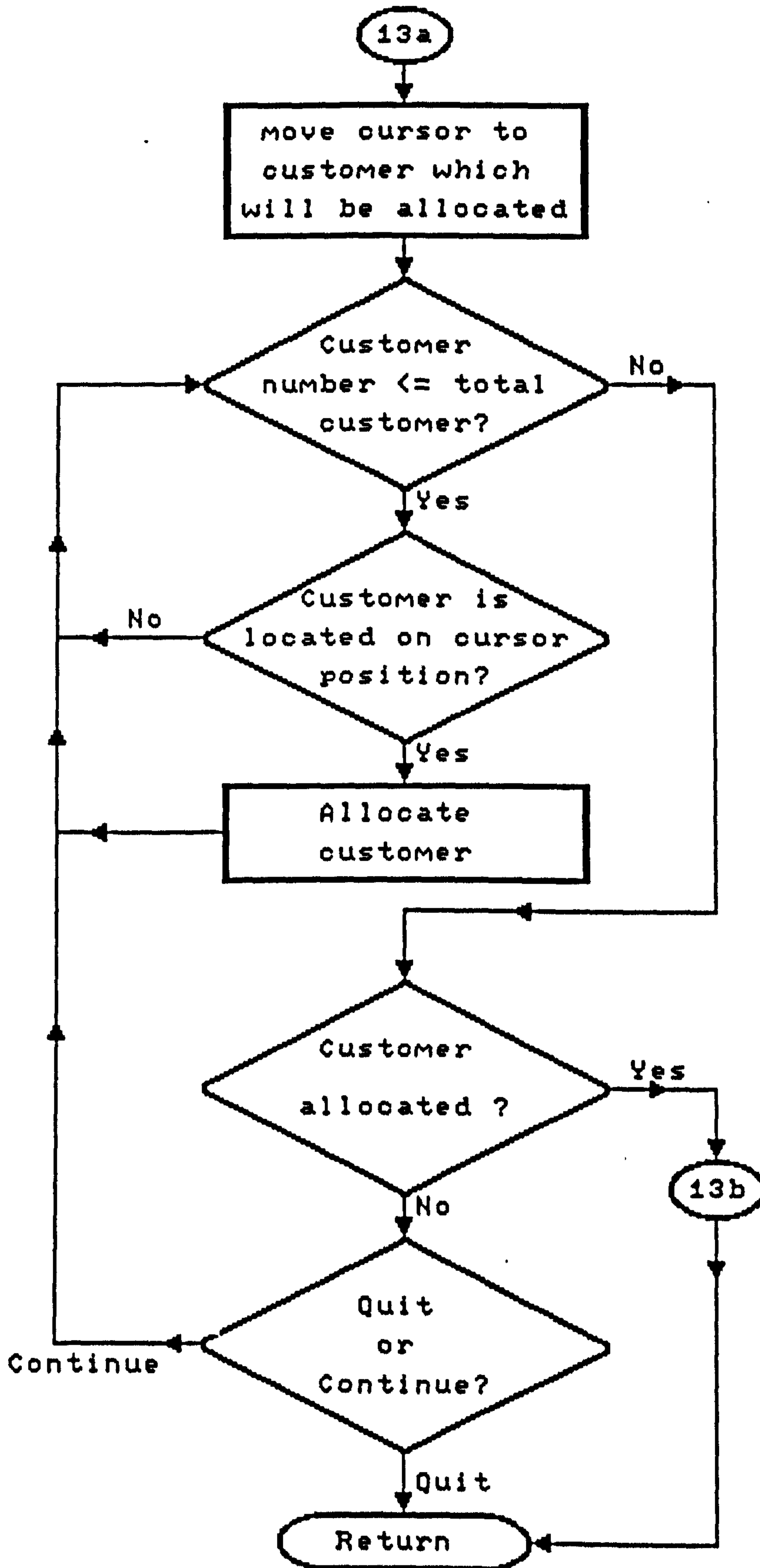

Figure 8.38a Subroutine MANAL1

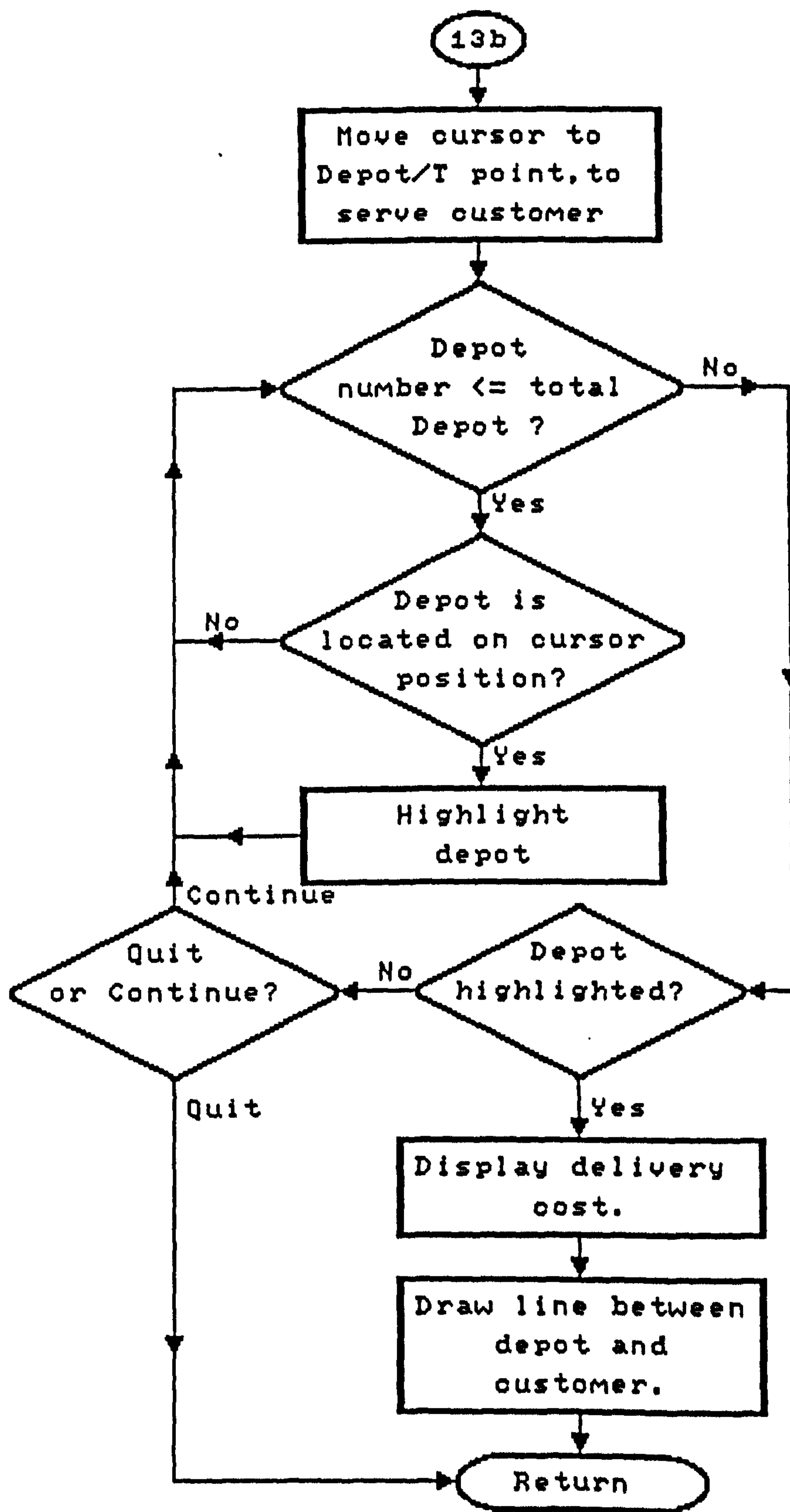

Figure 8.38b Subroutine MANAL1

8-75

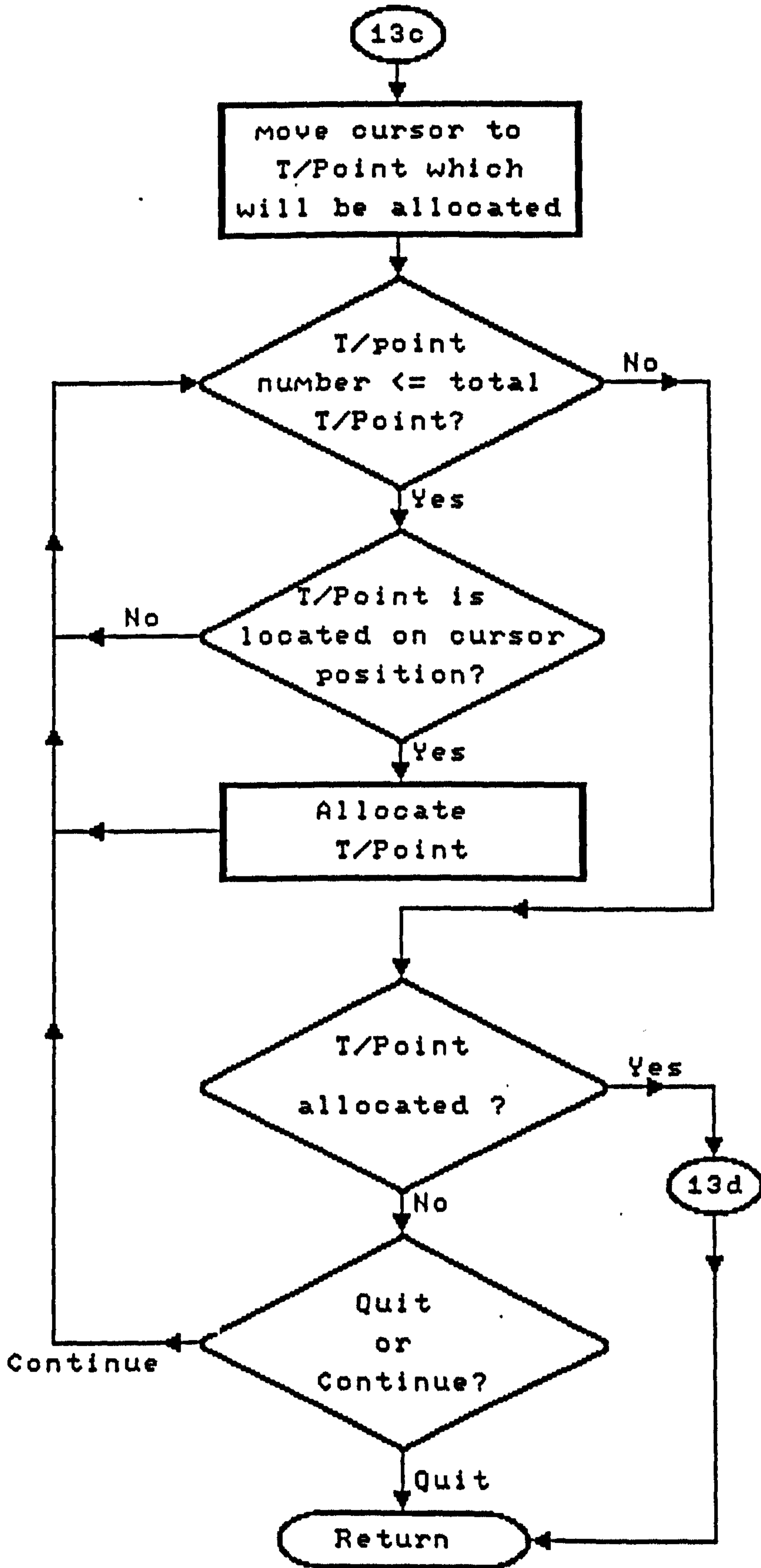

Figure 8.38o Subroutine MANAL2

8-76

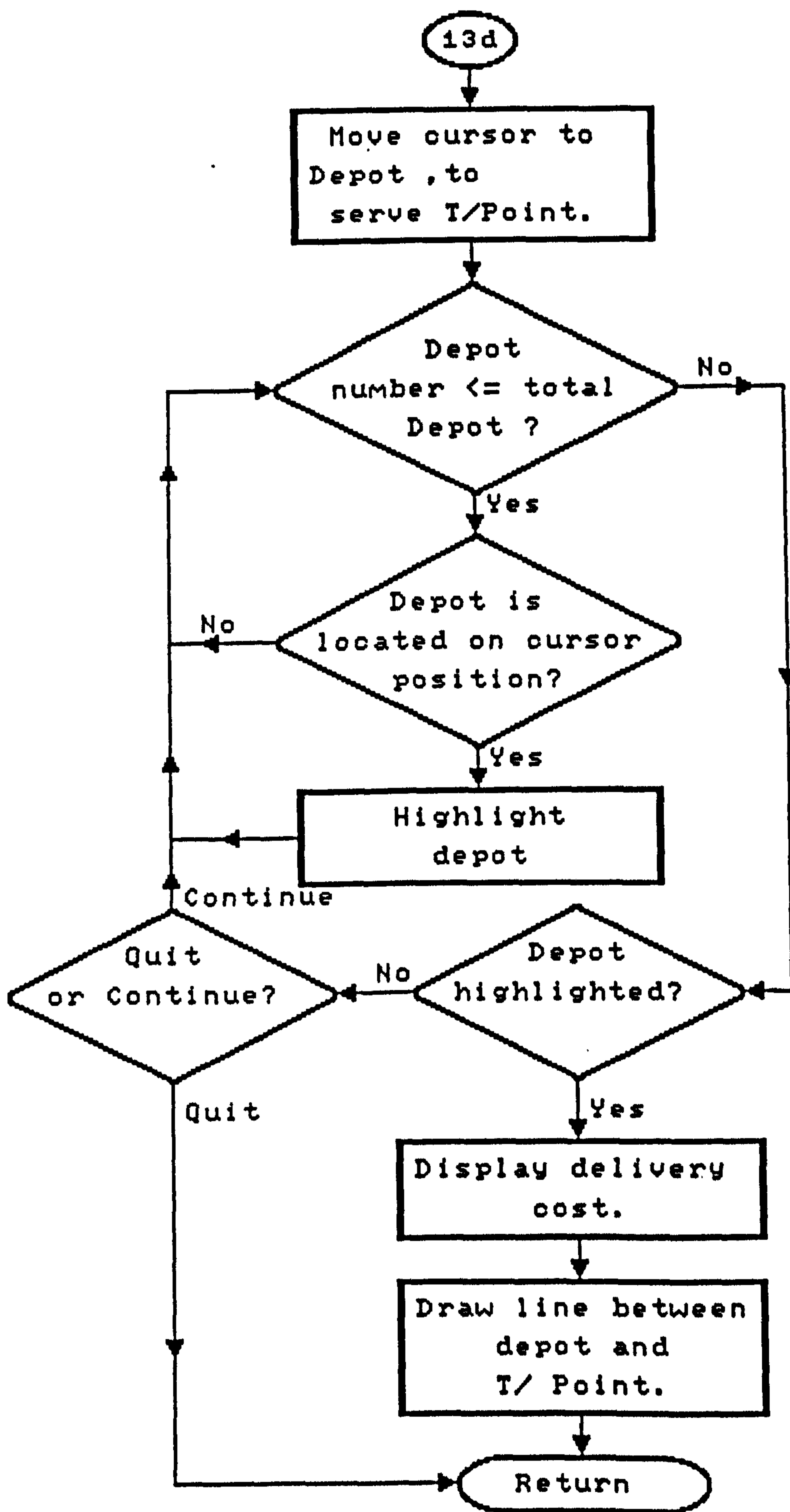

Figure 8.38d Subroutine MANAL2

8-77

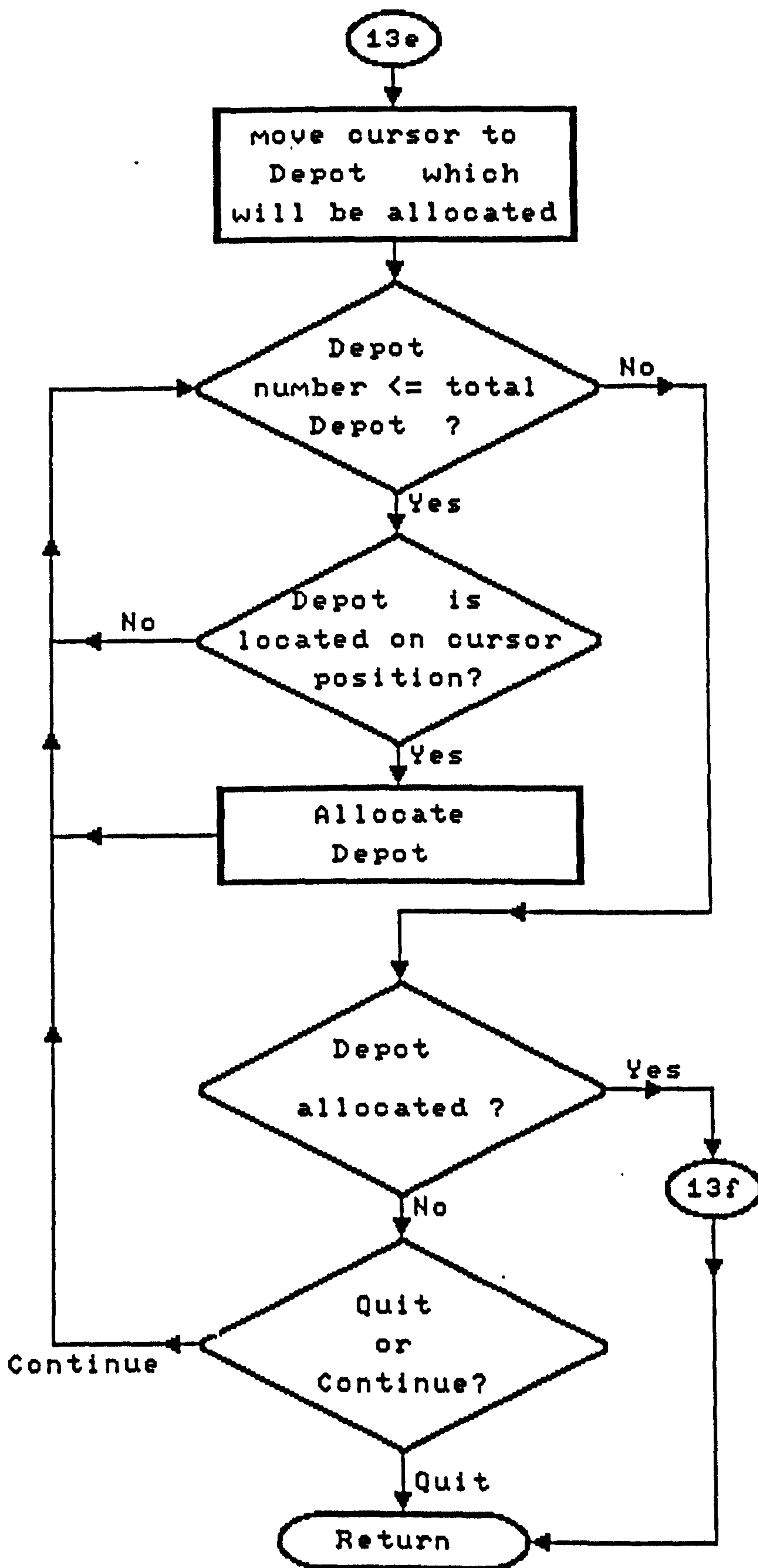

Figure 8.38e Subroutine MANAL3

and 8.38f. The subroutine performs the above procedure for depots and factories.

8.8 ALO6

This subroutine is employed to display the instruction menu for:

- factory information;
- depot information;
- print customer cost and location;
- print report.

The data flow diagram for this subroutine is given in figure 8.39.

8.8.1 PDETAIL

This subroutine is used to display the factory information on the screen. The data flow diagram is given in figure 8.40 and 8.40a. For each factory it displays the factory name, its location, total production, and the product that is produced. It also displays the number of depots that are being served by each factory and their throughput.

8.8.2 DDETAIL

The subroutine DDETAIL is used to display depot information on the screen. The data flow diagrams are given in figures 8.41, 8.41a, 8.41b, 8.41c, 8.41d and 8.41e. The display on the screen gives depot name, throughput, local delivery cost, trunking costs, handling and fixed costs, and inventory cost for each depot.

8.9 ZOOMING

Subroutine Zooming is used to zoom into any area on the screen to see more details of displayed maps and location of customers, depots, transshipment and factories. The data flow diagrams are given in figures 8.42, 8.42a, and 8.42b. The zooming subroutine checks whether a map point, customer, depot, transshipment point and factory is located inside or outside of zooming

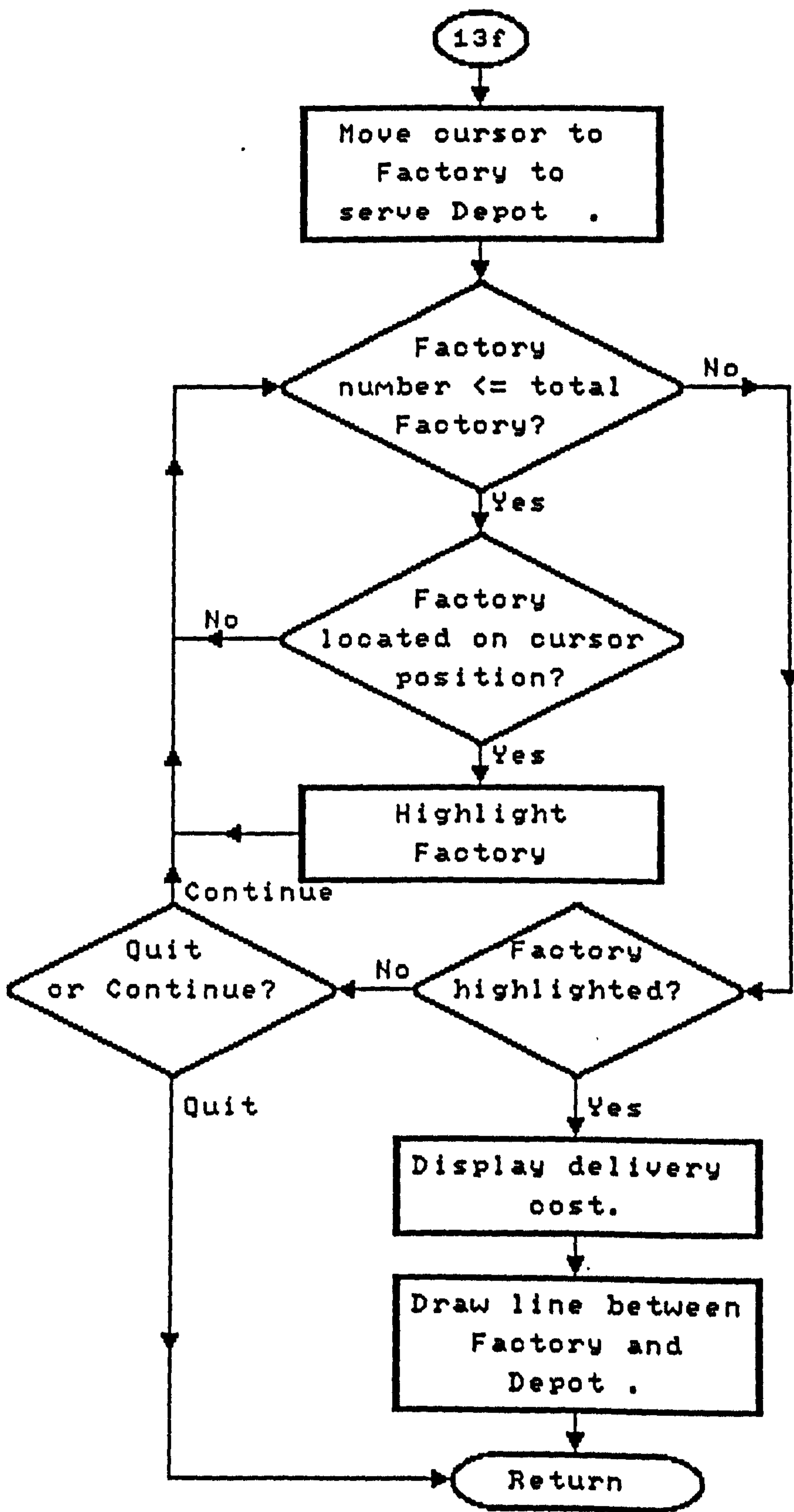

Figure 8.38f Subroutine MANAL3

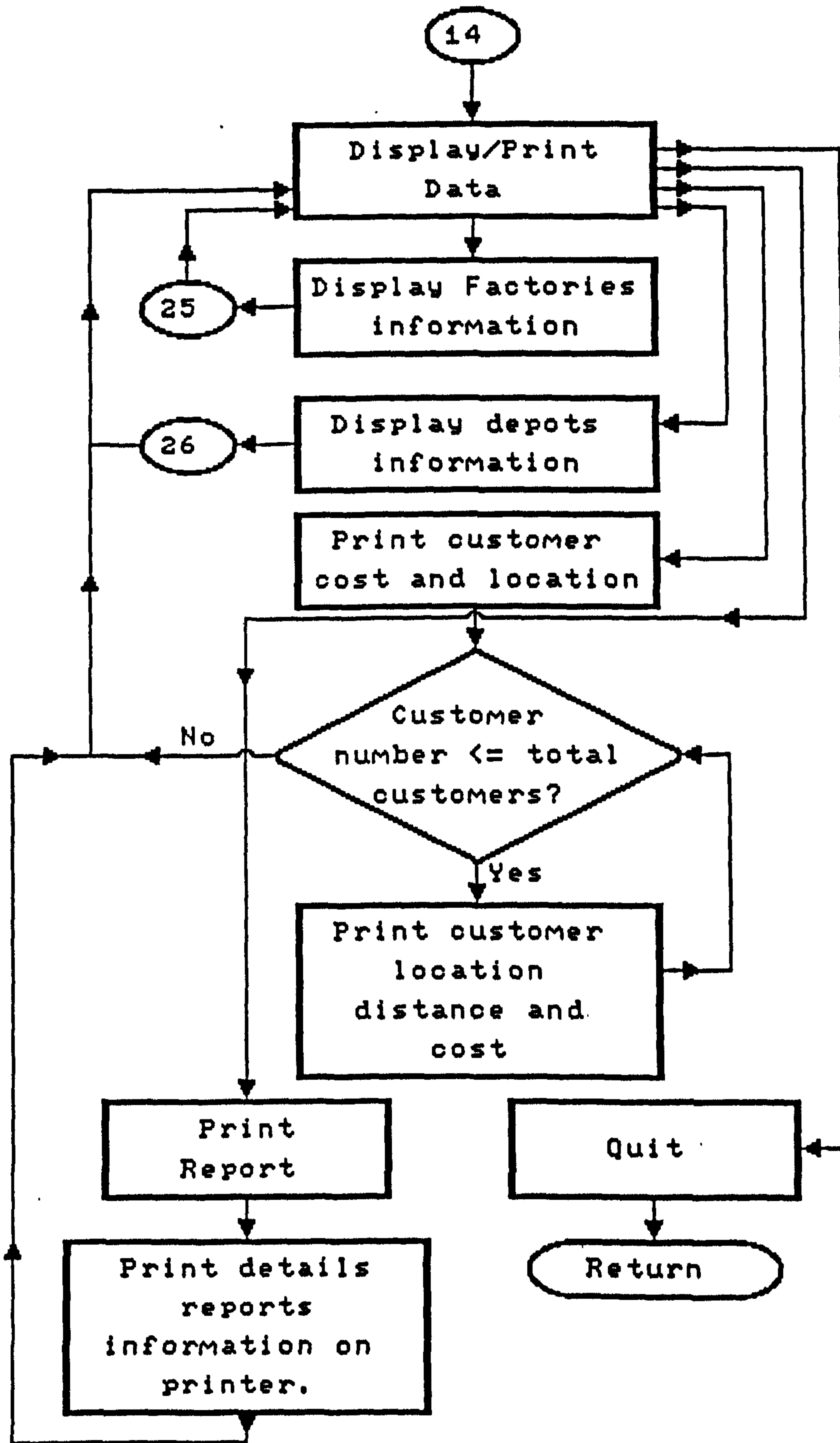

Figure 8.39 Subroutine AL06

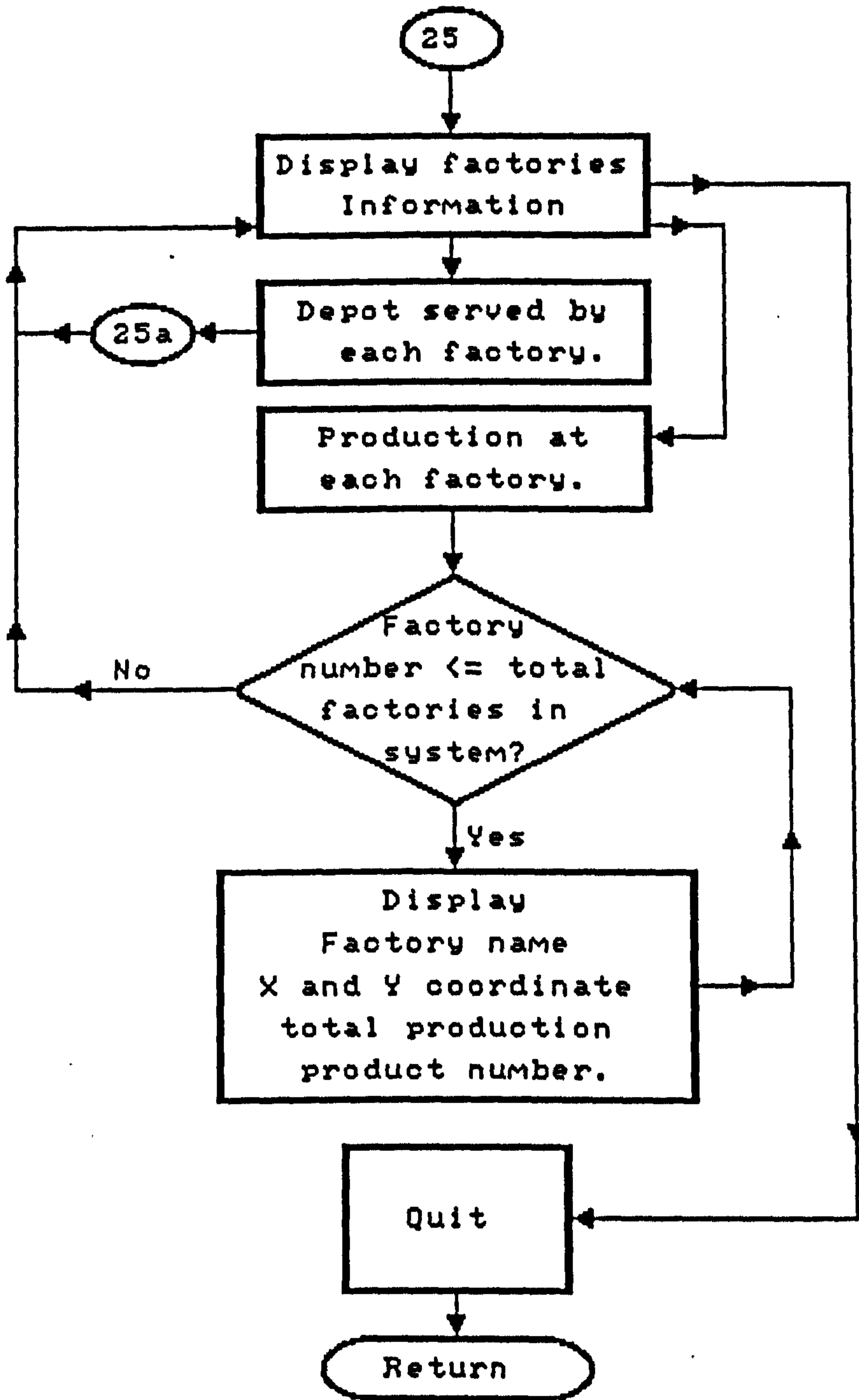

Figure 8.40 Subroutine PDETAIL

8-82

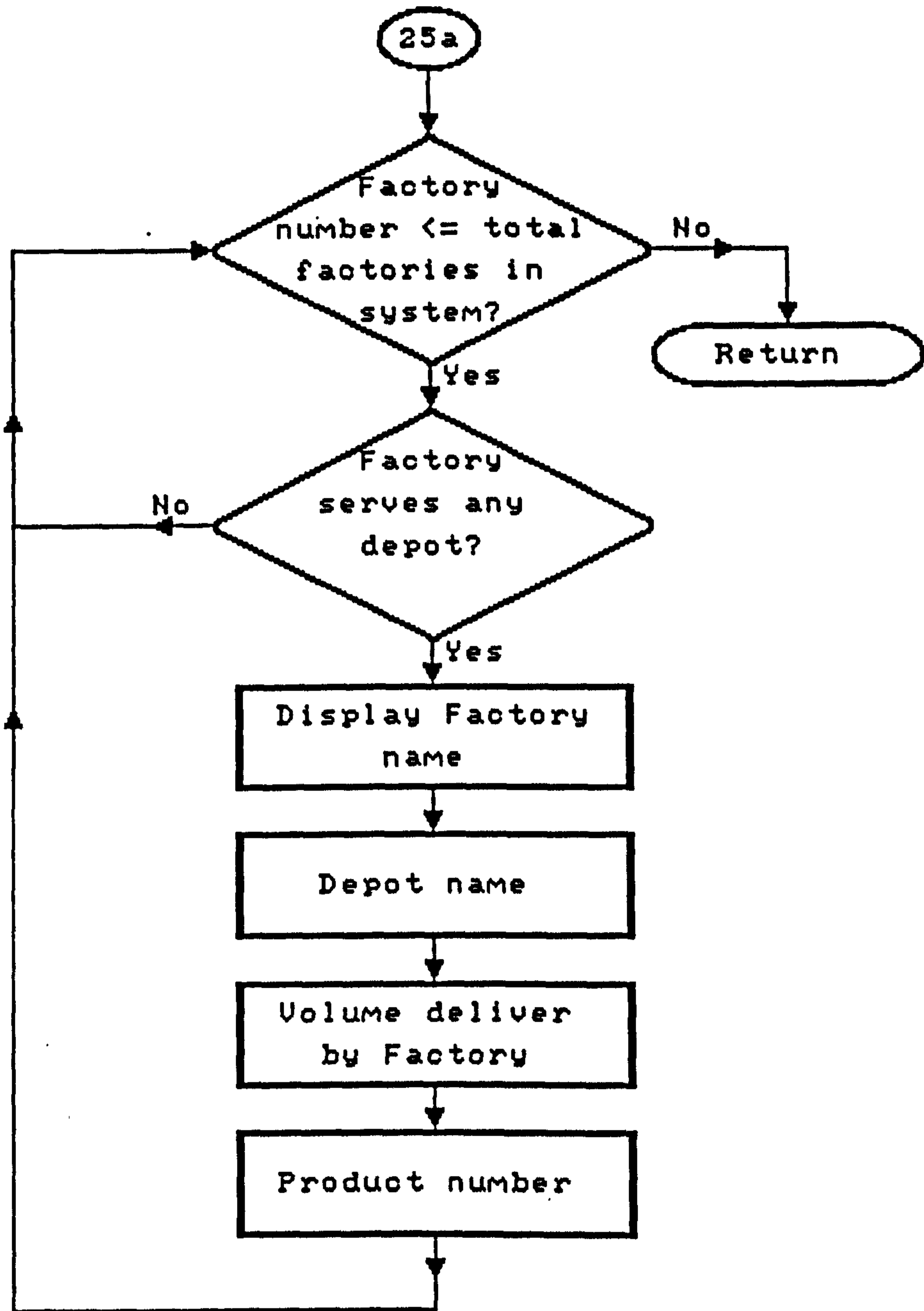

Figure 8.40a Subroutine PDETAIL

8-83

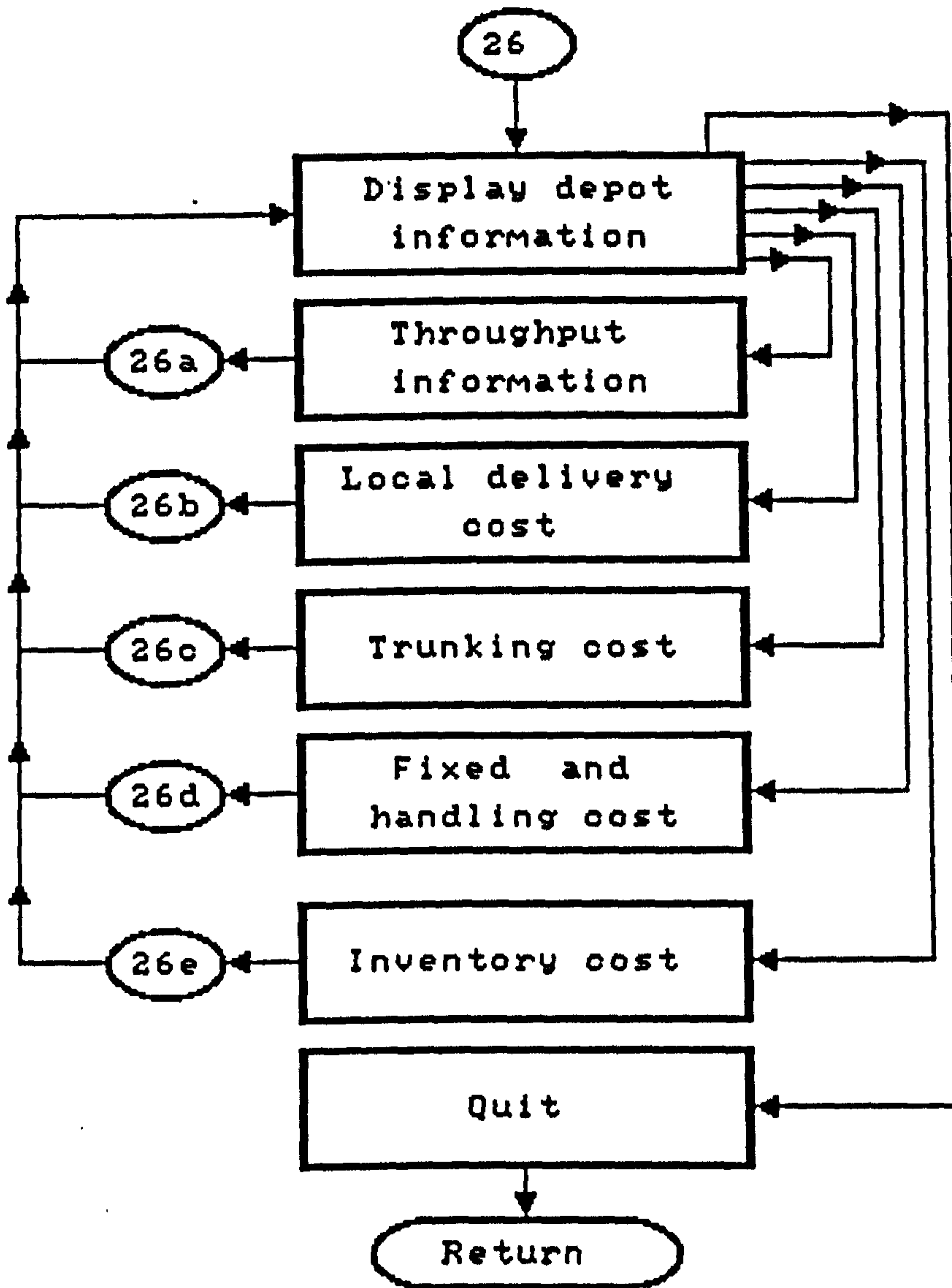

Figure 8.41 Subroutine DDETAIL

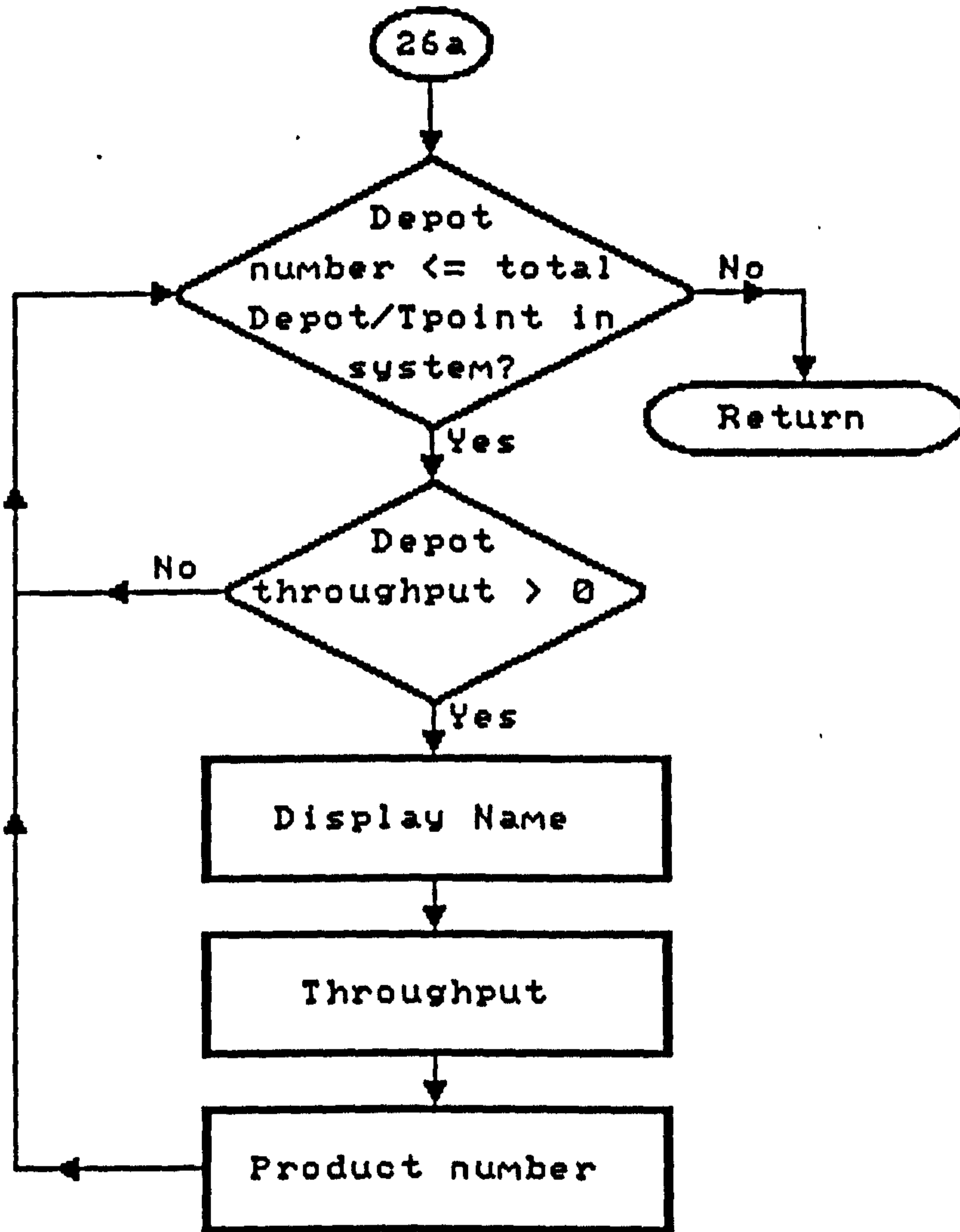

Figure 8.41a Subroutine DDETAIL

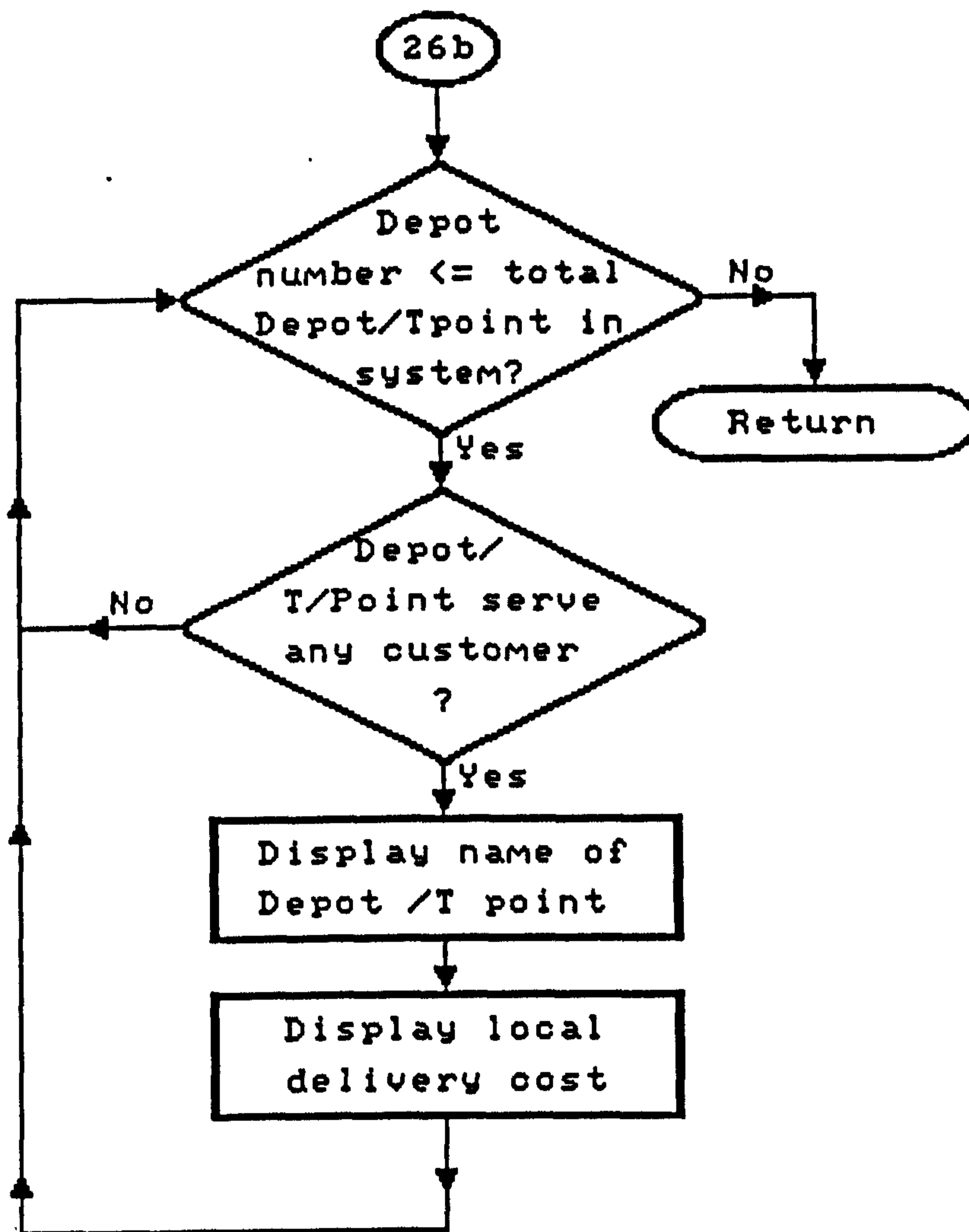

Figure 8.41b. Subroutine DDETAIL

8-86

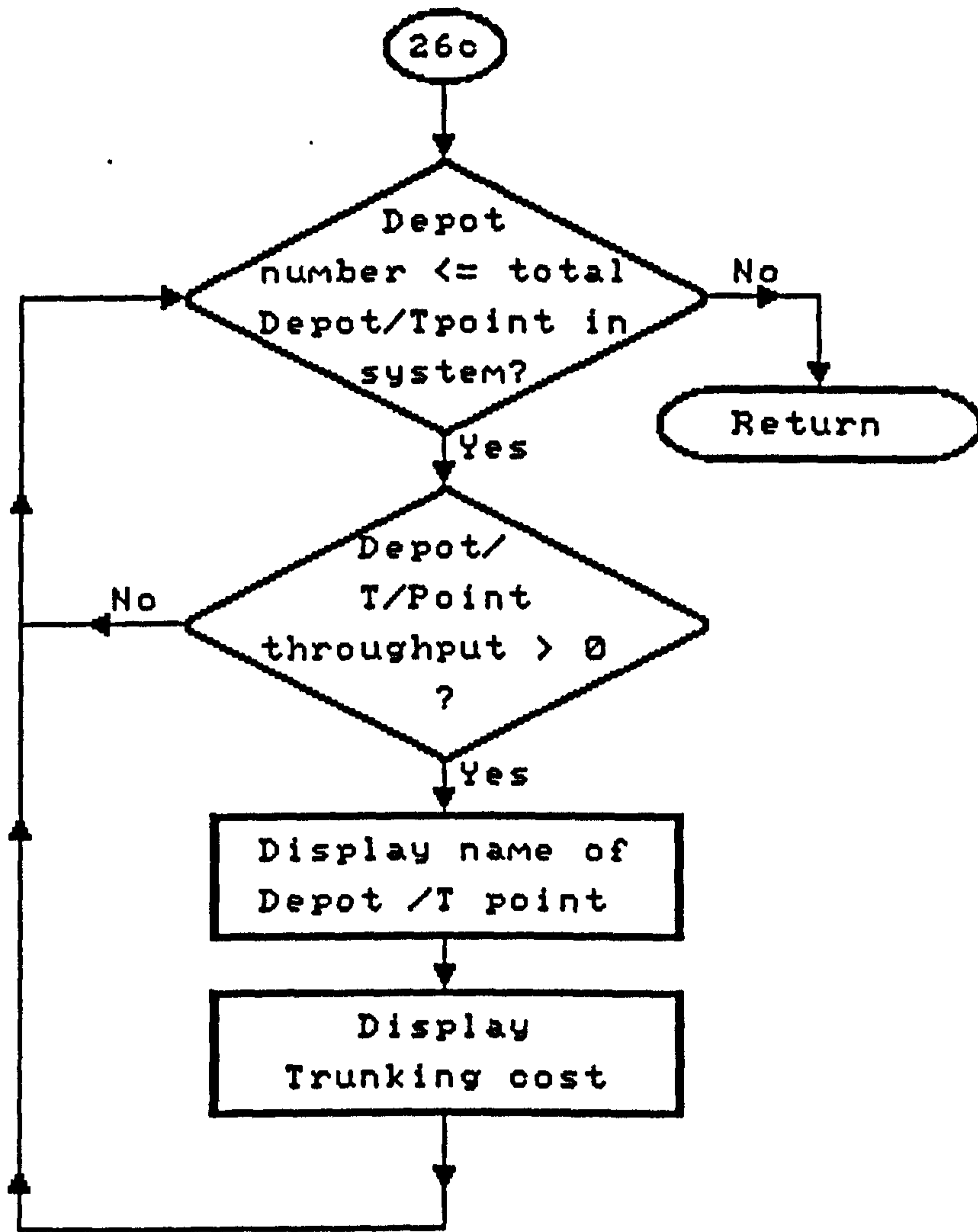

Figure 8.41c Subroutine DDETAIL

8-87

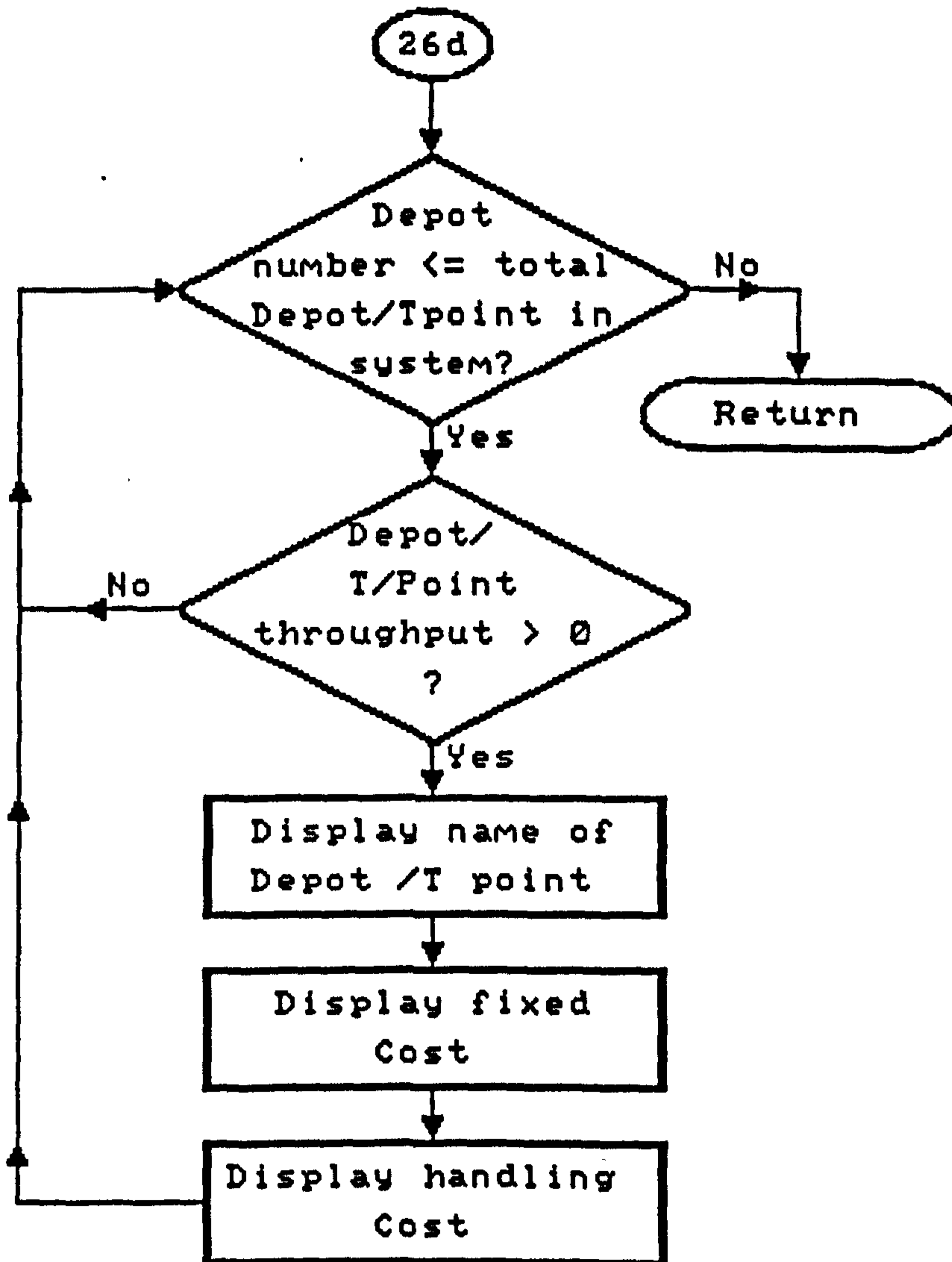

Figure 8.41d Subroutine DDETAIL

8-88

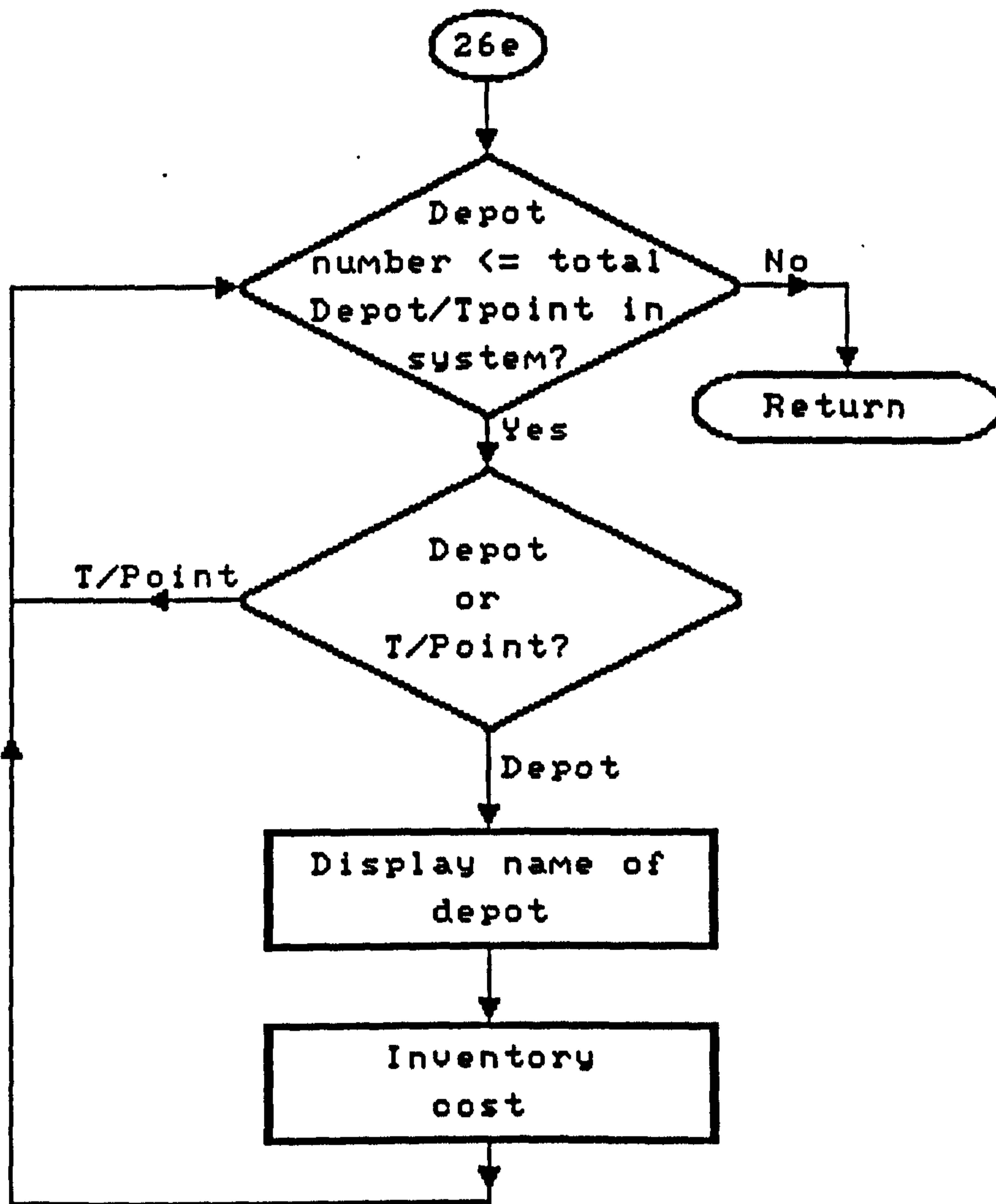

Figure 8.41e Subroutine DDETAIL

8-89

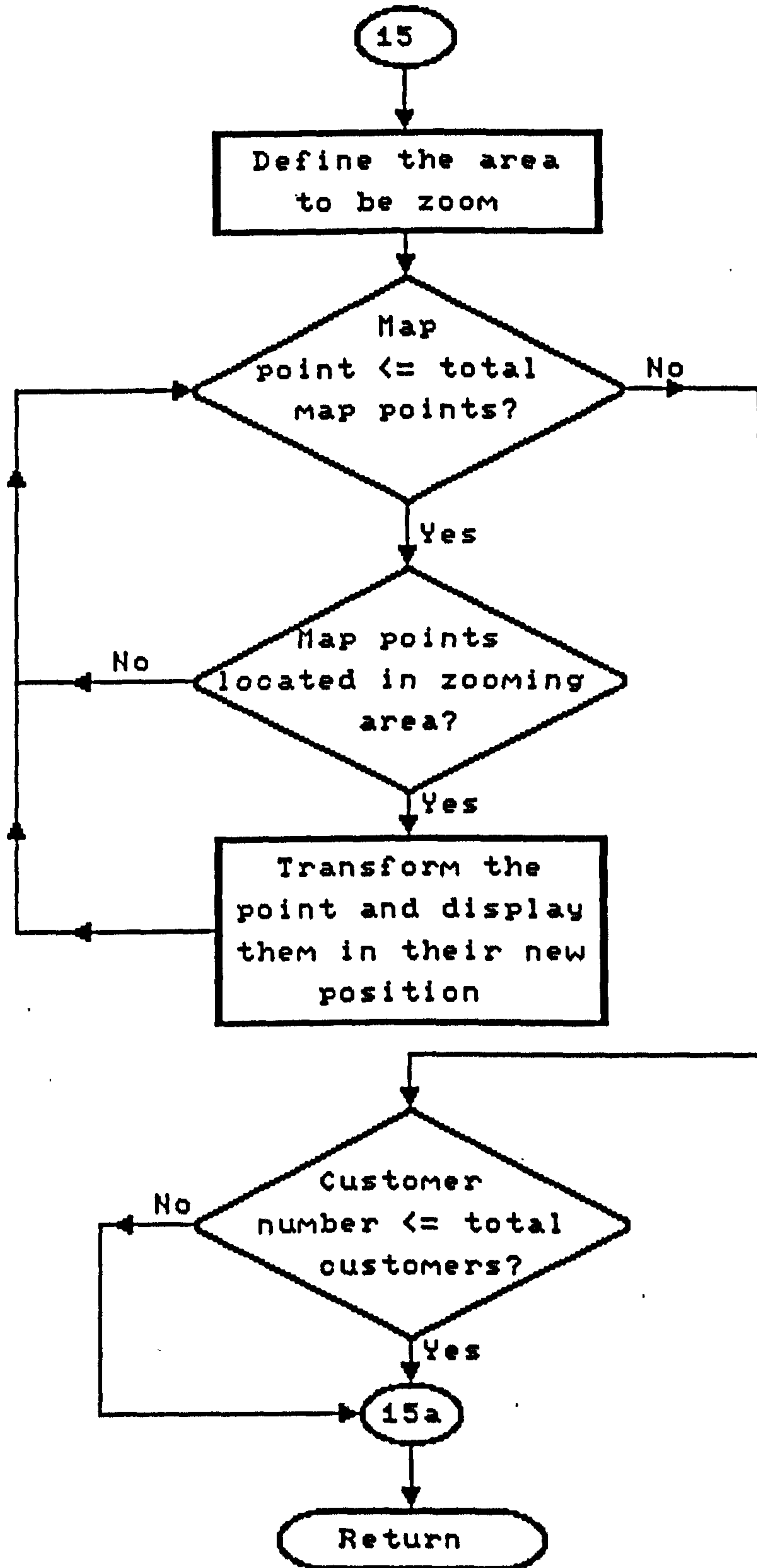

Figure 8.42 Subroutine ZOOMING

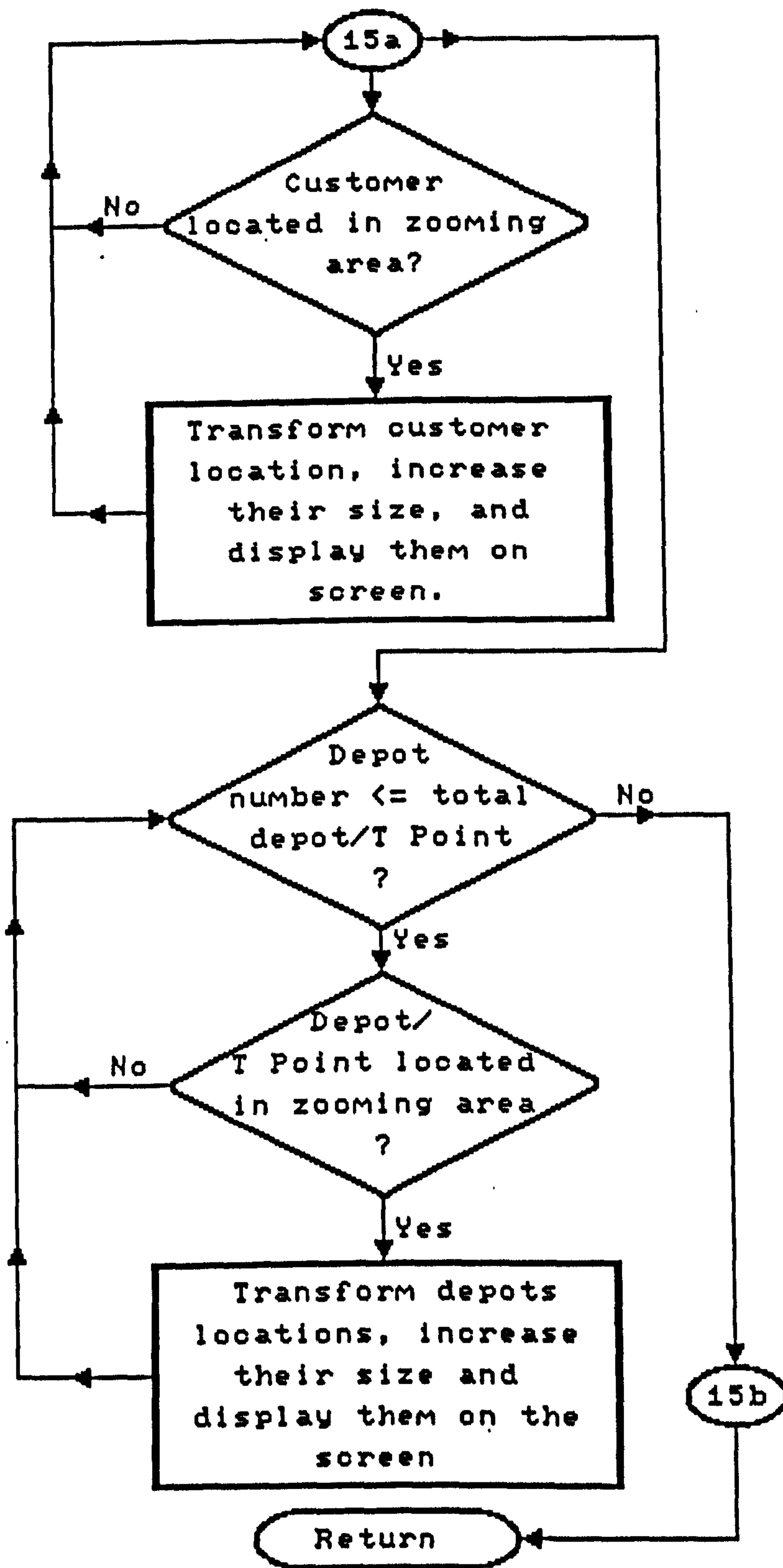

Figure 8.42a Subroutine ZOOMING

8-91

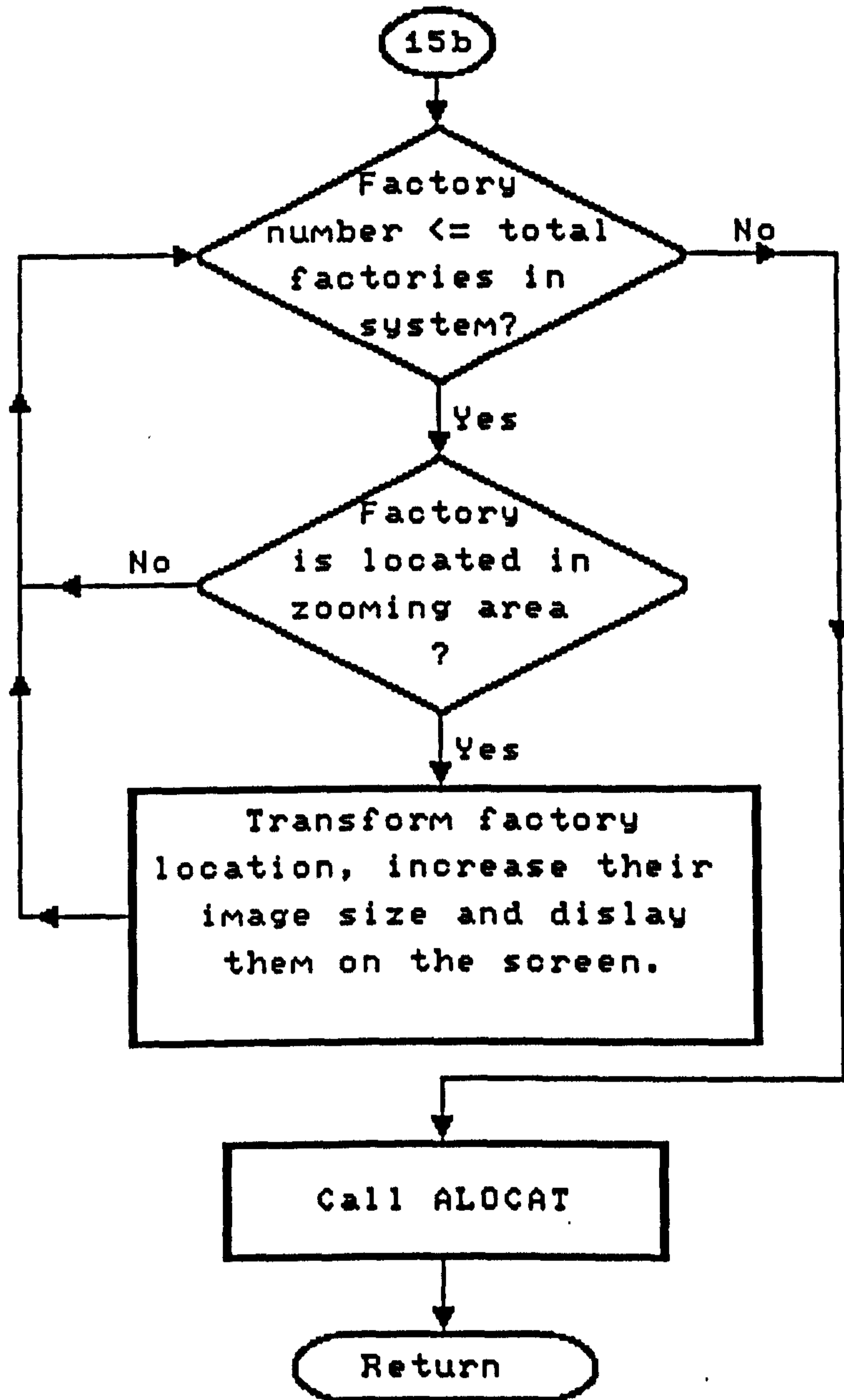

Figure 8.42b Subroutine ZOOMING

window. If they are located inside, they will be displayed on the screen and their size will be adjusted accordingly on the ratio of previous area and zooming area of the screen. The displayed customers will be allocated to the depot and transshipment point, transshipment will be allocated to depot, and depot will be allocated to source point.

8.10 PRINTS

Subroutine Prints is used to print the screen. LSM displays the colour graphics on the screen and if a colour printer is used then it will print the screen as displayed. If a black and white printer is used then it will convert the display colours on to the black and white printer. The data flow diagram is given in figure 8.43.

8.11 Conclusion

The format for each required file is depicted. The data flow diagrams for each subroutine is given. This will help to understand the structure and working of the model.

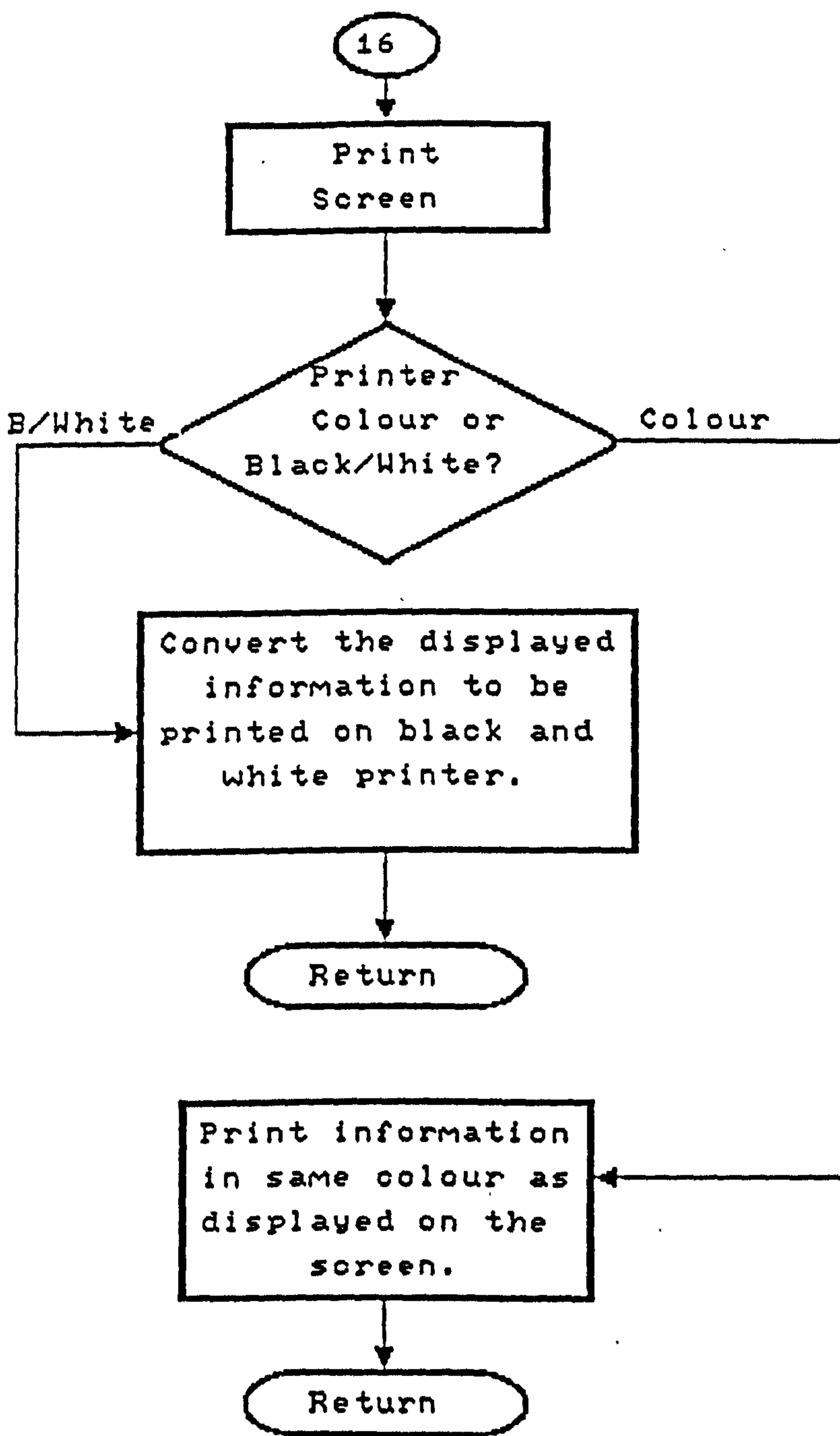

Figure 8.43 Subroutine Prints

Chapter Nine

Validation of Model

9.0 Introduction

LSM was developed for practical use, and there is no better place to test the model than on real world logistical problems. Of particular importance is the validation process and this is discussed in this chapter with respect to specific case studies. Also in this chapter the unique LSM approach to modelling logistics systems and the associated advantages will be discussed. Particular attention will be given to the detailed data requirements for modelling at the strategic level. The visual interactive approach and its contribution at validation, allocation and optimisation stages will be fully described. The advantages of a user friendly interface for modification, the speed at which results can be derived and the major contribution to distribution network system design will also be discussed.

The case studies which are described in this chapter could all have been carried out using existing distribution software, such as DiPS, Distribution Strategy Simulator and Stradis (which were reviewed in chapter five). They all have some disadvantages however :-

One major drawback is the extent of data required for these simulation models when they are used at the strategic level. Also to be able to handle the mass of detailed data they require the use of a mainframe computer. Another major drawback is their modelling approach. They are not capable of modelling logistics systems by using a visually interactive computer graphics technique.

LSM has been used for more than five case studies but only three will be discussed here. The first case study describes the problem and solution for a European chemical company, the second case study is based on the UK

operation of a European company and the third cases study is hypothetical, and is based on the distribution of cement in Pakistan. In each case, the problems and the background are described. The study objectives are clearly and concisely stated. The data collection and analysis are fully described and alternative logistics strategies are identified and tested. The solution actually presented to the associated company is not fully stated here for reasons of confidentiality. At the end of each case study the overall conclusions are presented and the model's contribution to the analysis and solutions are discussed.

Case Study A

9.1.0 Introduction

The overall project consisted of a comprehensive review of the Company's logistics system at European level and was undertaken by the Distribution Studies Unit. For this case study the focus will be confined only to those areas where LSM has been used, including the areas which affected input data and the associated results and conclusions.

In this case study, the LSM approach to designing a European logistics strategy will be discussed. This study was undertaken against the background of the removal of trade and customs barriers in the European Community and the introduction of the Channel Tunnel. These events are forcing companies to reassess and redesign their distribution networks on a European basis.

LSM is a decision support system and information presentation is of fundamental importance for any decision support system particularly to aid the decision maker. LSM presents information clearly, concisely and in a meaningful format on the computer screen. The map of an area which is being considered is a most important source of information for distribution network designer. For this case study LSM displayed the European maps on a colour computer graphics screen. The political boundary for each country

was represented in a different colour and sea areas were represented in blue. LSM displayed the production plants, distribution depots, transshipment points and customers on the map by employing different colours and shapes. The presentation of information in this format helped the user to overcome the 'black box' syndrome whereby the model user is unaware of the real implications and effects of parameter changes because there is no instant visual record of the effects of change. Another benefit is that the visual representation can significantly aid the process of assessing alternatives to test, can help the identification of associated problems and can highlight the acceptability of derived solutions at the (European) planning level.

The coordinates of the map, the location coordinates of production plants, distribution depots and customers were all in latitude and longitude. The great circle formula was used to calculate the distance between factory to depot and from depot to transshipment points and from depot/transshipment point to customers.

For this particular case study LSM included the local delivery cost, trunking cost, and operating and fixed cost for each distribution centre in a network.

9.1.1 Background

During the early part of 1988 a European Chemical Company asked the Distribution Studies Unit to review its existing distribution structure and design a European based distribution system for the mid 1990's. At the time each shipping point negotiated independently its freight requirements and rates, defined its own carrier portfolio and determined its own storage needs. Although this might achieve local optimisation of resources, there is an inherent danger of sub-optimizing the total distribution operation.

Thus it was felt by the company that it may benefit from the development of a more explicit European strategy for distribution, particularly for bulk shipments. There were many opportunities for the company to consider at the

European level, such as:

- carrier partnerships
- opportunities for bulk rather than bag deliveries
- backhaul opportunities
- direct delivery versus satellite storage
- different unit load concepts
- alternative transport modes

The company thus believed that there was a need for a strategic review of its distribution system.

9.1.2 Objectives

The overall objectives for the study were defined by the company as follows:

"In the light of existing market-place, and anticipated developments into the mid 1990's, define a distribution strategy which will support the business strategies by offering competitive cost and service advantages, and securing the company's physical distribution requirements."

9.1.3 Approach

To achieve the overall defined objectives the project was divided into two stages. The terms of reference for stage I were as follow:

"To review the existing operations and policies related to bulk distribution and to produce a database for subsequent use. To determine relevant external factors and their impact on these operations. To identify a wide range of options for distribution developments in the business ".

LSM was not used for stage I objectives, but these objectives will effect stage

II, therefore they will be briefly described here.

A number of approaches were adopted in order to identify the major strategic and operational options. These included:-

- a review of existing company sites and operations to identify relevant site related factors and constraints
- the collection, collation and analysis of data and information from the company's computer databases
- the identification of relevant external factors to the company's operations

Many different options were identified and these were broadly categorised under the following headings:-

- * Customer Service Policy
- * Distribution Competitive Edge
- * Distribution Structure
- * Channels of Distribution
- * Information Network
- * Modal Choice

The term of reference agreed for Stage II of the study were as follows:-

"To examine in more detail the alternative distribution strategies for the 1990's. To determine the likely future requirements of customers and their attitudes to changing distribution strategy. To perform the detailed database collection exercise establishing an appropriate database for distribution strategy modelling at several levels, including an aggregate sourcing model examining the alternative sourcing

policies for the 1990's and distribution strategy modelling to compare the cost of different modes, stock-holding policies and locations ".

To achieve the defined objective, the following method of approach was adopted:

- ◆ determine a list of distribution options for consideration;
- ◆ Physical handling survey of company's customers
- ◆ 1992 survey of transport and distribution developments in chemical industry in Europe.
- ◆ Cost and other data collection
- ◆ Develop a source model to help identify the major product flow for 1992.
- ◆ determine an acceptable business strategy including sourcing and distribution;
- ◆ identify an option short list;
- ◆ use the LSM to test the various options identified;
- ◆ recommend a distribution strategy and plan associated with the preferred business strategy and taking into account practical considerations.

9.1.4 Stage II Options Identification

A number of options were identified. The main categories are given in figure 9.1a.

From an initial qualitative assessment the following were assessed to be worth further consideration:

a) Customer Relations

- * Defined service levels
- * Make logistics costs visible
- * Define customer needs/profiles

Main Categories	Number of options
Distribution structure/Channels of distribution	43
Contractual arrangement	39
Modes of transport	39
units loads	18
Bulk filling/handling	38
Customer relations	33
Competitor relations	17
Carrier relations	9
Company's opportunities	45
Total	281

Figure 9.1a

b) Company's Opportunities

- * Logistics organisational structure appropriate for future development

- * Company's European Integration - Logistics
- * Company's European Integration - Sourcing
- * Eliminate sub-optimisation - Transport
- * Product Rationalisation - European Sourcing
- * Be proactive rather than reactive
- * Gain knowledge of and monitor competitors.

c) Distribution Structure

- * Develop Distribution Structure
- * Develop Information Network

d) Contractual Arrangements

- * Europe-wide arrangement/co-ordination

e) Modes of Transport

- * Container by Rail
- * Leave tank/silo/box at customer premises

f) Unit Loads

- * Use of 20 ft, 30 ft containers

g) Bulk Filling /Handling

- * Loading time availability

h) Customer Relations

- * Make logistics costs visible

i) Competitor Relations

- * Understanding/gain knowledge of competitors logistics strategy

j) Identify appropriate/competent carriers

9.1.4.1 Physical Handling Facility Survey (PHFS)

The physical handling facility survey was undertaken by the Distribution Studies Unit to provide a positive input to the determination of a recommended distribution strategy. A summary of the most relevant strategic results and implications are outlined below:-

- * There are few important delivery restrictions.
- * For bulk, inventory levels are at approximately 7 production days
- * Bulk deliveries are mainly by road tanker. Company is similar to its competitors
- * Very few customers have rail heads at their sites
- * A majority of customers have rail and container terminals within 20 kms
- * Generally, bag unloading and storage is more expensive than bulk unloading and storage
- * There is potentially significant site labour savings if bulk storage and distribution is used rather than bag
- * Moving from bag to bulk is acceptable to most customers but this does depend on the product, grade, etc. that is supplied
- * By the mid 1990's the proportion of the customers taking greater than 60% bulk rather than bag will be significant (A change from current 39 % to expected 69 %)
- * At least 50% of customers plan to change physical distribution aspects by 1993. The major change is to increase bulk storage facilities.
- * 30% of customers expect a significant move to JIT by the mid 1990's
- * There are some plans to use EDI by mid 1990's (11 % Yes, 21 %

Amenable).

A broad statement describing current attitudes might be that customers are generally conservative towards change, but they are planning to increase their use of bulk into the 1990's.

9.1.4.2 West European Chemical Industry Survey

A survey of distribution in the chemical industry in Western Europe was also conducted by the Distribution Studies Unit and a summary of the major results and implications were as follow:-

- * Increases in plant capacity are planned by many companies (63% of the respondents) and increases in product demand are generally expected.
- * there will be a change in dominance from bag to bulk distribution (bulk 45% to 53%, bag 53% to 41 %).
- * A move to just-in-time distribution is expected. This will involve faster transit time, greater use of EDI.
- * a more competitive, pan-European transport environment is foreseen. This should come about through:-
- * harmonization of transport legislation (vehicle weights,etc) - deregulation : giving freedom to negotiate prices,etc.
- * direct delivery will continue to be important, but there will be a definite move towards stock being held closer to the customer. This will lead to an increase in central,regional and transshipment container depot systems.
- * there will be increased use of rail and intermodal transport and an important increase in the use of containers. Road tanker transportation will continue to be dominant.
- * there will be a move to the use of a few pan-European distribution companies,and a move away from using a large

number of small transport operations.

- * there is no interest in the ownership of distribution companies by the major producers.
- * the importance of effective logistics information systems was highlighted.

9.1.5 The Major Options

A number of different distribution structures for the Company were identified as follows:-

- * direct delivery (as at present)
- * central depot
- * regional depots
- * transshipment or stockless depots
- * container depots
- * any combinations of the above

The main implications for the bulk distribution operation were:-

- * depots with bulk silos are not feasible (for onward bulk distribution) due to handling and capital costs
- * direct delivery to local customers is always likely to be the most cost effective alternative
- * all depot options are feasible using ISO containers as the basic transport/unit load.

A number of alternative channels of distribution were considered:-

- * preferred haulier (as now)
- * contract out whole operation
- * Company's own account
- * Company's own account plus third party carrier for selected aspects
- * partnership with haulier (s)

In general, own account and partnership options were not favoured for several reasons. The 1992 survey results as well as other sources indicated the growing trend for transport and distribution to become more specialized. Additionally, there appeared to be a significant move towards large pan-European distribution companies enabling more centralised negotiation to take place.

9.1.5.1 Short List of Options

The following short list of options were agreed with the company and these options were further investigated by using LSM.

* as current structure (all direct delivery)

The company was interested in this option to understand the cost and other implications to meet the mid 1990's defined objective without changing the distribution network structure.

* a central stockholding and distribution depot/hub using containers;

In this option the company was interested to move all stocks from factories to Hub depot by trunking and then use local delivery to deliver to local customers. The company was particularly keen to understand the strategic impact and cost of having a central depot.

* a number of regional stockholding and distribution depots using containers

In this option, the idea was to design an optimum distribution network to meet the defined business objectives.

9.1.6 Using LSM

The present geographic distribution of customers and production plants are given in Figure 9.2a. Figure 9.3a shows the production in metric tons at each production plant at 1988 levels. Figure 9.4a shows the demand in metric tons

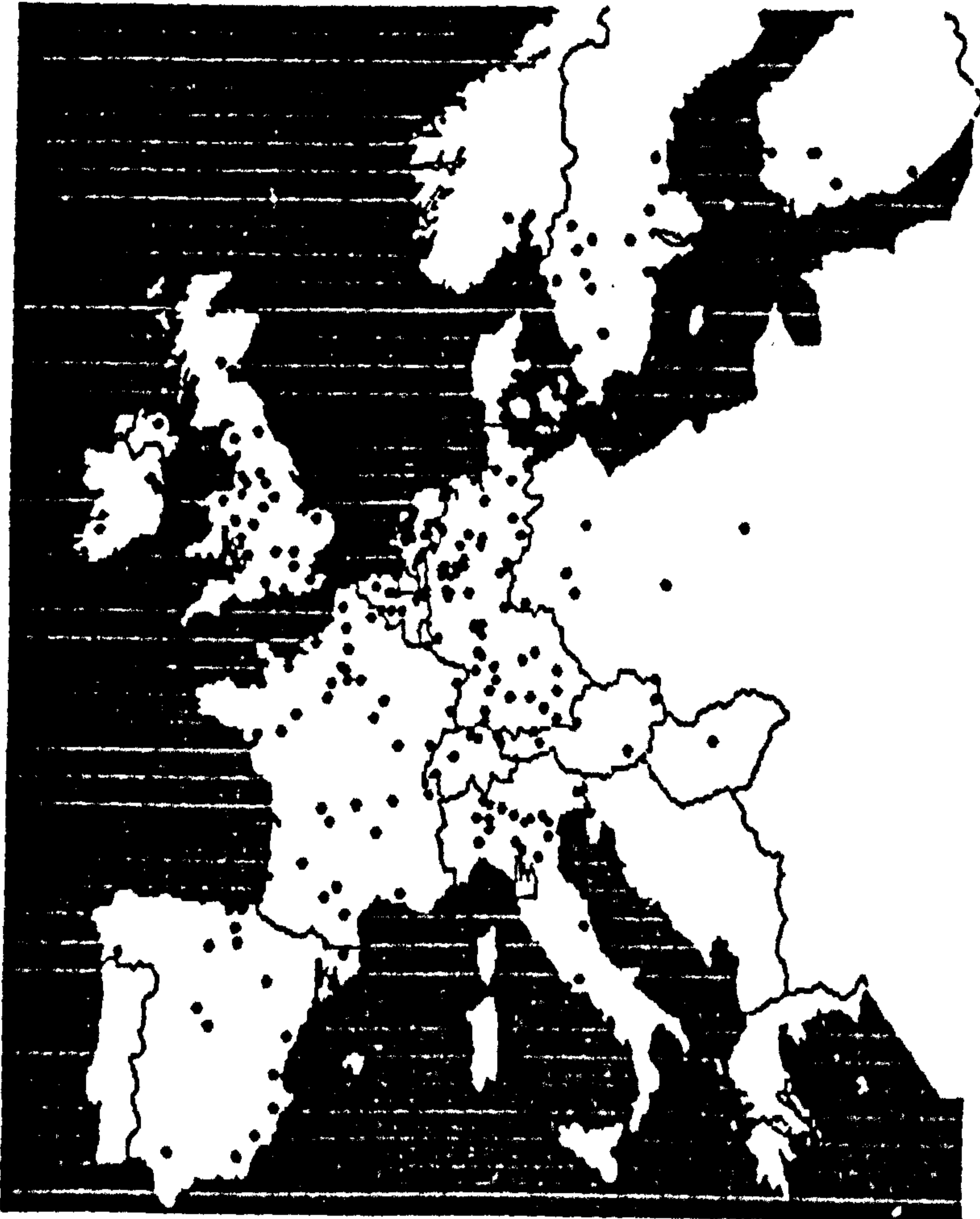

Fig 9.2a Geographical distribution of customers and production plants

Production versa Plants

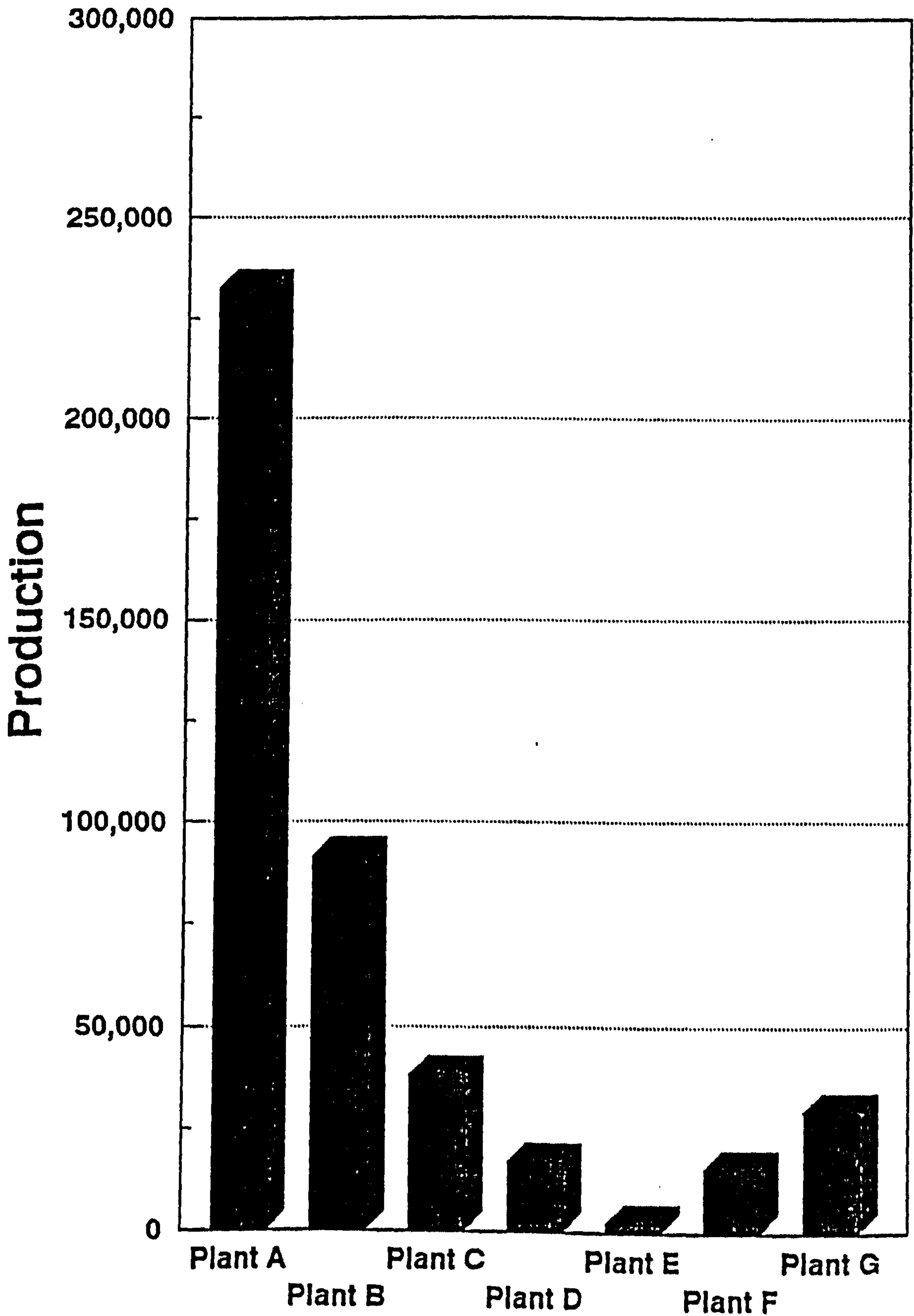

Fig9.3a Plants

Total amount transported to each country Products

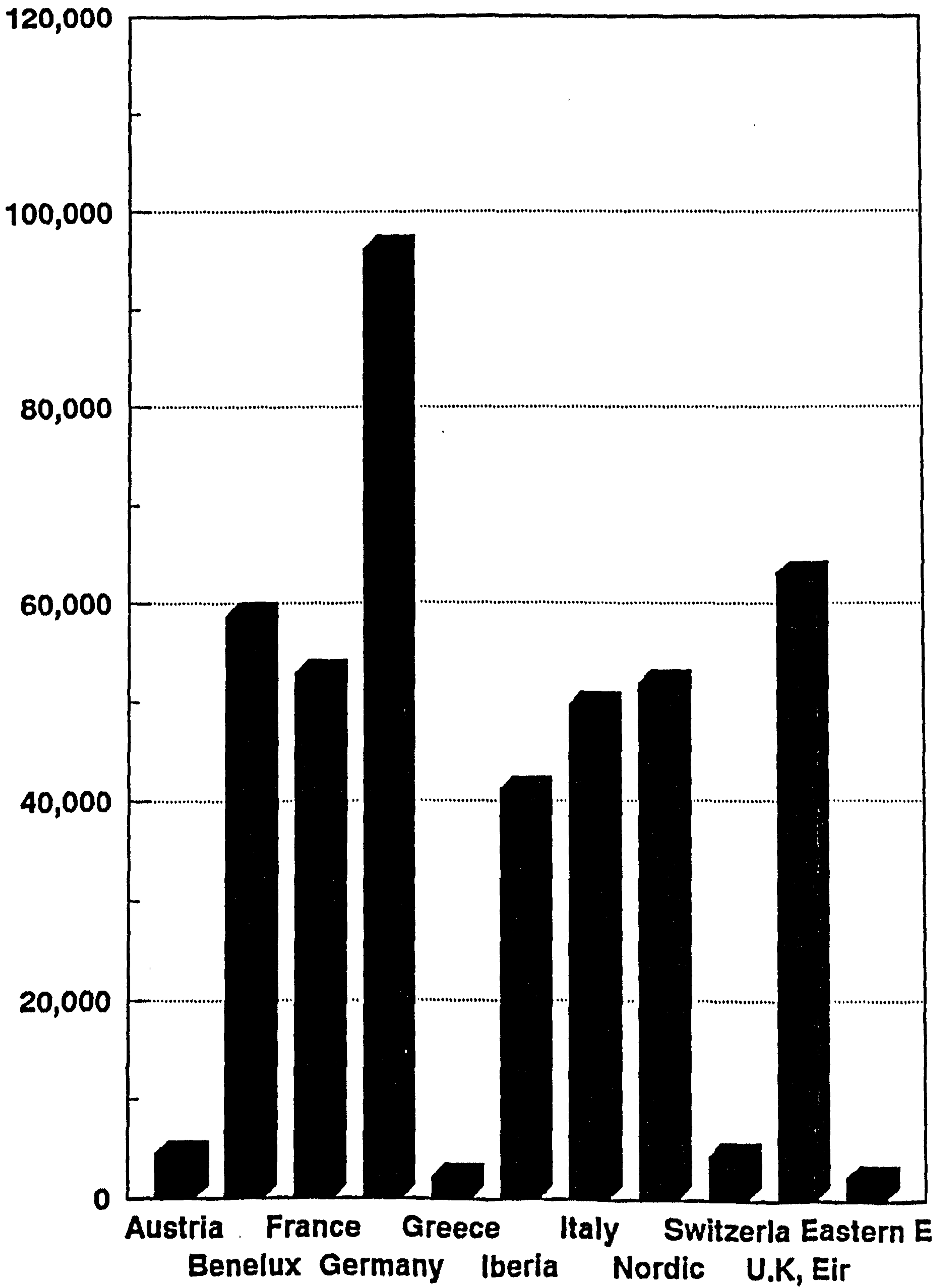

Fig9.4a

Country

for each country on 1988 basis.

The following implications can be drawn from this information;

The company's customers are distributed all over western Europe. Plant A has the highest production, followed by plant B. Germany has the largest demand.

9.1.6.1 Validation

The validation of a model is a very important feature in logistic systems modelling. The credibility of any proposed distribution strategy depends on how closely the model reflects the existing situation at the validation stage. The validation of a model is different from the conformation of a model. For the conformation, a model is logically tested (to ensure such as two plus two makes four). At validation the model has to reflect the existing distribution system.

The data used for validation purposes is critical to the modelling process in a distribution system. In the market, on the one hand there are simulation models (chapter five) which need a great deal of data which is often not available or is difficult to estimate, and thus make the simulation exercise unrealistic. On the other hand there are optimisation models which for the sake of true optimisation leave a great deal of information out. The drawback with these models is that they may give an optimum distribution network but this network may not reflect the company's true situation. LSM utilises a middle approach. It needs a reasonable amount of data to reflect the real situation and generally this data is readily available and allows for an accurate representation of the distribution system.

In order to validate the LSM, the (1988) distribution pattern for bulk product was used as the demand data. The company provided the location name for each town where a factory was located as well as present production and future production capacity. It also provided the location name and demand for

each town for customers throughout Europe. The latitude and longitude for each town were read from a European map. Some towns in Finland were not on the map but their locations were provided by the Finnish Embassy in London.

Model Road-tanker cost	\$ million 12.187
Actual Road tanker cost	\$ million 12.07
Model container cost	\$ million 7.71
Actual container cost	\$ million 7.81
Cost of Road-Tanker	37.3 \$ /MT
Cost of Container	74.5 \$ /MT
Over all Cost	46.6 \$/MT

Table 9.1

The cost functions which were used for validating the LSM were developed from regression work undertaken in Stage I of the study together with additional external cost data where this was required. The results of the model showed good agreement with the actual costs, differing by less than 1%. The actual values are shown in Table 9.1.

The visual interactive modelling technique advantages at the validation stage were very clear. The model clearly displayed the allocation of each depot to production plants and the width of the line between them indicated the volume flow from plant to distribution depot. The area served by each distribution depot was shown by the lines drawn around the distribution depot. Each depot area line was in a different colour. This helps the user to observe which depot is serving which area. The overall modelling approach was accepted at the validation stage because the company managers were

able to see the image of their distribution system on a computer screen in a meaningful format. A hard copy of the validation image is not provided here because it is difficult to understand on black and white print.

9.1.6.2 1992 Model Runs

In order to model the 1992 situation, the demand data needed to be increased to a 1992 forecast. The expected percentage increase in demand from each plant to a country is given in table 9.2a. The customer database file of 1988 was modified and demand was increased to 1992 expectations.

9.1.6.3 Existing Policy

To understand how the present system would operate in 1992 with the expected demand increase, the LSM was run by using 1992 demand data. All depots were located at the factory site with zero fixed cost. All customers were served by local delivery as at present by using the current local delivery cost function. Total costs increased because demand in 1992 was forecast to increase. The average unit cost for 1992 demand was 44.6 \$ /MT. This is a realistic result given the 1992 demand increases. It shows for the company that costs will rise if no new strategy is designed to handle the future distribution demands. It also provides the 'base' run against which all subsequent option results can be compared.

9.1.6.4 7 Container Depots

The siting of seven container depot was one of the options tested on the 1992 demand database. The initial location of container depots was based on large demand areas. They were located at North of France, South of France, Germany, Italy, Sweden, Spain and United Kingdom. The model provided an optimal allocation of customers to depots and the resultant average cost was reduced to 43.2 \$/MT. Thus the overall distribution cost was reduced compared to the 1992 base cost.

Percentage increase from each plant to a country for 1992

Country	Plant A	Plant B	Plant C	Plant D	Plant E	Plant F	Plant G
Austria	100	218	0	214	0	0	0
Benelux	147	191	452	0	0	0	7219
France	100	121	77	100	0	0	1052
Germany	140	124	0	0	0	0	938
Greece	100	100	0	0	238	135	0
Iberia	250	100	0	0	0	0	332
Italy	110	244	0	129	0	0	35715
Nordic	111	128	100	0	0	0	6600
Switzerland	133	100	0	0	0	0	305
U.K Eir	167	217	110	0	0	0	4479
Eastern Europe	100	100	100	0	0	0	0

Table 9.2a

9.1.6.5 7 Container Depots (Optimised Locations)

The model is able to search for a best possible location for a depot (Optimisation). When this function is employed in a multi distribution depot network such as in this case, it continues to move the depot and reallocate the customers until it can't reduce the system cost any further. This procedure moved the depots to Scotland, Frankfurt, Karlstad, Barry, Antwerp, Rome and Bilbao. The overall cost was reduced from the previous cost to 42.6 \$ /MT. The movement of depots and the cost associated with each

cost to 42.6 \$ /MT. The movement of depots and the cost associated with each position were clearly visible on the screen during the analysis. The results indicate the improved structure together with the reduced costs. Use of the LSM model enabled the search procedure to find a better solution than was possible by visual inspection.

9.1.6.6 Sensitivity Analysis on Depots

LSM does not determine the minimum number of depots required for a distribution network. Therefore sensitivity analysis was undertaken concerning the most appropriate number of depots. LSM has a facility whereby throughput of each depot can be displayed on the screen. Also a depot can be deleted visually by pointing the cursor to a particular depot. By using this first function to examine which depot has the least throughput and using the second function to discard that depot from the system, it is relatively easy to test the implications of different depot numbers and locations on the overall distribution structure and cost. After each revision of depot numbers the optimization facility is used to produce the least cost solution. The total number of depots against the total cost are plotted in figure 9.5a.

Figure 9.5a shows the total logistic cost for each distribution network by using the LSM. The total system cost is reduced as depot numbers are increased from 0 to 7. The average cost / MT is plotted in figure 9.6a. The average cost is lowest for the seven depot option but increases as additional depots are excluded.

9.1.6.7 Hub Depot

Many companies are interested in the implications of having a Hub depot located centrally in Europe. This has advantages such as keeping inventory, stock and administration in a central position. This company was also interested in having a Hub depot located centrally in Europe. Product would then move from plants to Hub depot and then from Hub depot to customers.

Number of Depot VS Total Cost

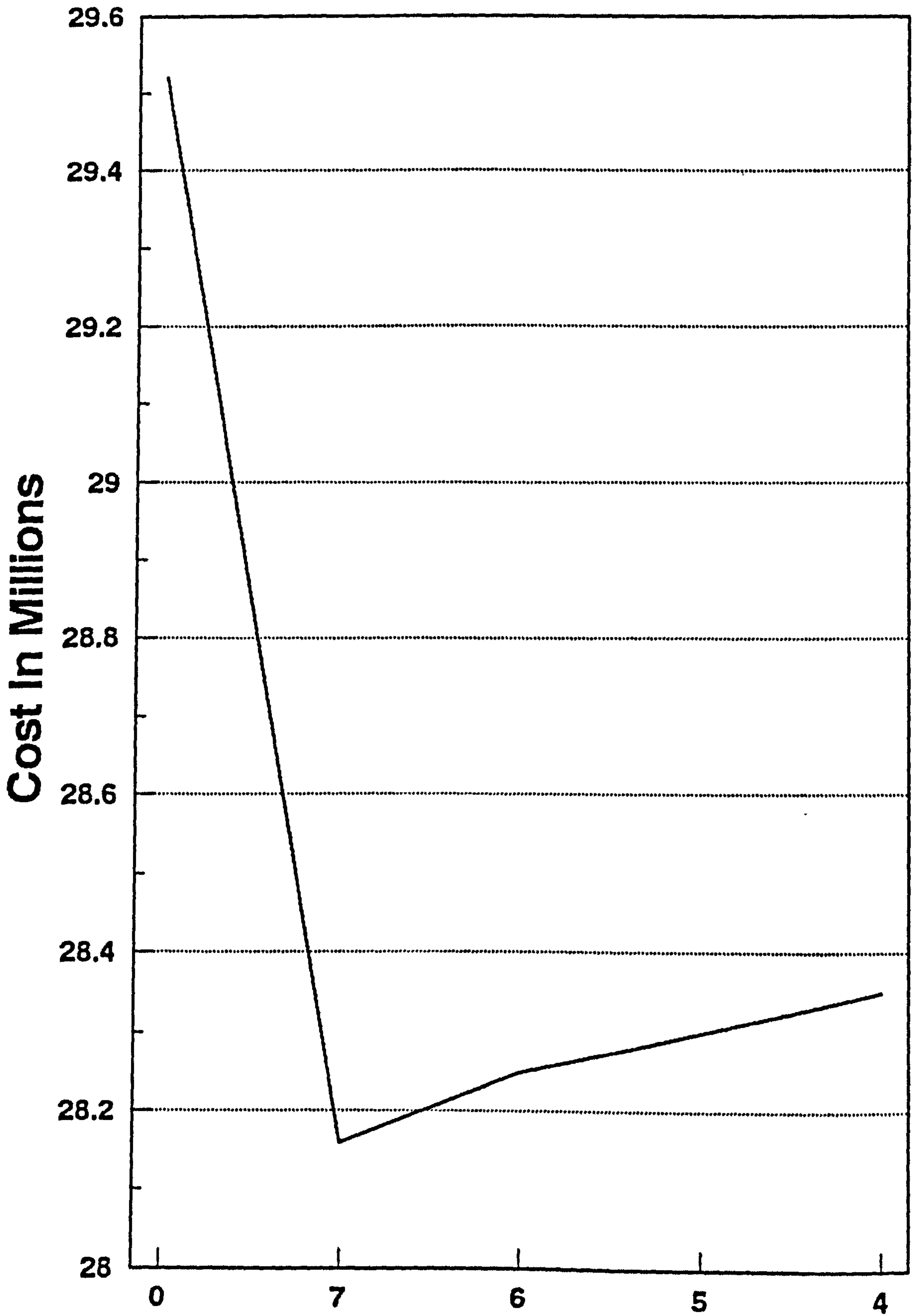

Fig9.5a Number Of Depots

Number of Depots Vs Cost/MT

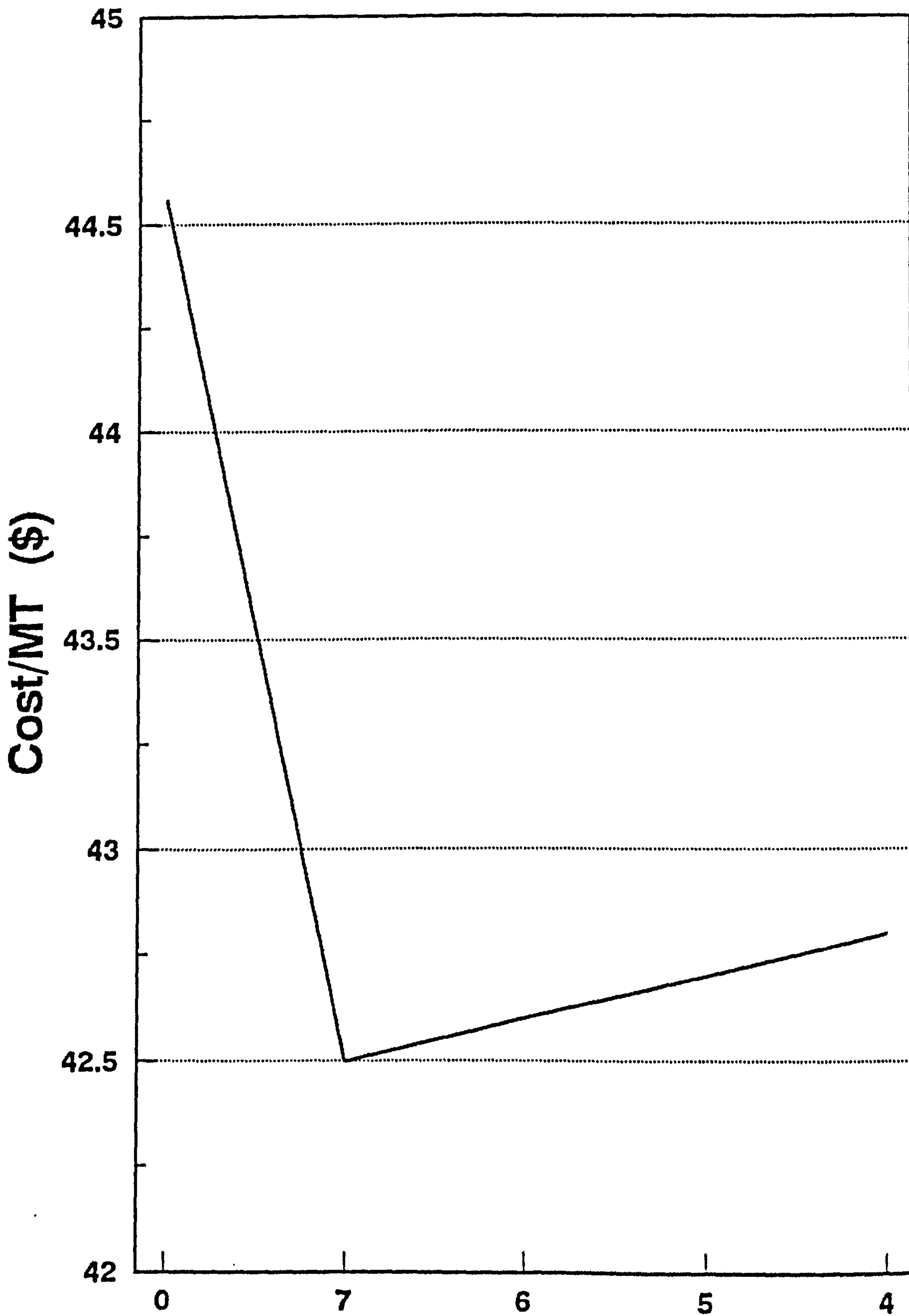

Fig9.6a

Number of Depots

The minimum number of depots LSM needs to model a distribution system is one. Therefore LSM was used to test the Hub depot option for the company. This option produced much higher costs than the base run and other options. Clearly the Hub depot option is not suitable for the company.

9.1.7 1992 Options

As described previously the company has two unit loads for the movement of product : bulk and bags. To model the overall distribution network structure the demand for both of these were combined to design a single distribution network structure for 1992.

9.1.7.1 Option 1

One main option was that the current distribution policy is maintained but the bulk ratio of company product is increased and sourcing is improved. When this system was modelled by using the LSM the following was result was obtained.

The total sales for 1992 are expected to be 1.6 million MT. From this 0.69 million MT will be transported by bulk movement. The remaining product will be transported by bags. The estimated transportation cost for bulk is approximately \$ 30.54 million and \$ 43.27 million for bagged. The overall cost is \$46.24 per metric ton. The handling/packaging cost will be reduced because bulk is cheaper to handle than bags. This cost will be approximately 2.4 \$ /MT less than 1988 values. To handle the increased bulk product, the company would need additional storage space, so there would be an increase in fixed costs. This cost was estimated outside the model and at around 18.2 million US dollars.

9.1.7.2 Option 2

The second option considered was if the company maintained the bulk and bag ratio to 47: 53 but improved sourcing using the four container depots located at Milan, Gothenburg, Lyons, and Rome. When this system was

modelled the resultant overall transportation cost was reduced to 44.22 \$ per metric ton. Since the bulk ratio was being increased from its present ratio the handling and packaging cost was reduced from 1988 values. The ratio of bulk to bags are the same as in option one therefore handling costs will be reduced in the same ratio as described in option one. Increasing the bulk ratio will require some extra storage space and fixed costs were estimated to be 6.5 million US dollars.

9.1.7.3 Option 3

The third option tested using the model was that the company should change the bulk and bag ratio to 55:45 with improved sourcing and keep the same container depots as in option two. When this option was modeled by LSM the resultant overall transportation cost was further reduced to 43.63 \$ /MT. Since the company is increasing the bulk ratio significantly the handling/packaging cost was also reduced by 4.8 \$ /MT. The fixed cost for the storage space was around 4.6 million US dollars.

9.1.8 Conclusion

LSM enabled the various distribution strategy options to be tested at the European level by visually interactive means. The visual approach used by the model clearly helped at the validation, allocation and optimisation stages to demonstrate what was happening in the black box. The major conclusions to be drawn by the company from these analyses were:-

The single hub depot is not a cost effective alternative for its distribution network structure for 1992.

The increased use of containers, incorporating intermodal transport and linked to a transshipment type of depot structure provides distinct cost and service advantages.

Some form of depot/transshipment point structure based on containerised

distribution will provide significant cost savings.

The four depots distribution structure is likely to be the most viable and cost effective, with depots located in the vicinity of Milan, Gothenburg, Lyons and Rome.

Potential savings in bulk distribution costs, based on the above scenario, and compared to current methods are approximately \$3.80 per mt transport costs (\$46.6 mt 1988, 42.8 mt 1992) and \$4.8 mt handling costs. At an estimated bulk throughput of 660,000 mt, this represents an operated saving in the region of \$5.5 million per annum. An increase in silo capacity to cover the additional plant throughput would be required at an estimated capital cost of \$4.6 million.

The greater the move away from bag and towards bulk distribution the greater is the potential for cost saving.

The particular contribution from LSM to design this distribution strategy were;

Information was presented clearly and concisely, was easily understandable and was in a meaningful format through the use of computer graphics directly on the computer screen. The map clearly showed the area under consideration for modelling the distribution system. The geographical locations of factory, depots and customers confirmed the existing and recommended distribution structure.

The flow of demand from each production plant to distribution depot was presented graphically by width of line, which clearly showed the high demand area for a particular product and the distribution of production from each producing plant.

The boundary of each distribution depot and transshipment point were drawn in a different colour. This clearly showed the serving regions boundary for each distribution depot and transshipment point.

Any modification was very logical and easily attainable. Most of the parameters were changed by simply using the cursor. For deleting a facility the cursor was moved over it, for adding a facility anywhere on the map the cursor was moved to the required location and for moving a facility from one place to another the cursor was used to transfer it from one location to another.

The LSM search features for optimal location for depots or transshipment points were particularly valuable in this case study. This is because of the visibility on the screen of what the black box was achieving. Each time a depot was moved, the new cost was displayed on the screen. The overall cost was seen to be lower than the starting cost for that depot configuration, thus giving confidence that a correct cost had been derived.

LSM runs on a micro computer, therefore it was easily transportable on a portable computer to present the results at the company premises. In addition , micro computers are much more user friendly than mainframe computers.

LSM is a very user friendly model and easy to understand. The users were able to learn to use it quickly, to develop and test alternative options easily and to use it to present the results to the board.

Case Study B

9.2 Introduction

In this case study, all the LSM features which have been described in the previous case study were used but some additional features were also tested.

All coordinates such as map line points, factories, depots and customers

locations were in kilometres. Distances were calculated by using pythagoras' theorem. Straight line distances were converted to actual distances by using an appropriate wiggle factor. The value of the wiggle factor is very well researched for the United Kingdom in the available literature. To enable the matching of model distances to be as close as possible to actual distances, hazards and barriers were also incorporated. Barriers allow for rivers and mountains to be taken into account and hazards allow for town and city centres, congested road networks and poor road networks to be taken into account.

Another feature that was incorporated into the model allowed a distribution network system to be optimised where some depot sites are fixed but others are moveable. This provides a distinct practical advantage over classic optimisation models which have 'all or nothing' optimisation thus making it difficult to model existing logistics structures where some locations are fixed.

In this case study source points were also moved from their existing positions. This showed that LSM can be used to design a distribution system not only moving, adding or deleting depots but also the source points.

9.2.1 Background

This study was conducted for the U.K division of a European company. They recently (1989) procured two additional companies in the United Kingdom with a view to having a combined distribution strategy for the whole country. The three divisions of this company will be simply known as A, B and C for reasons of confidentiality. The three divisions were importing goods from mainland Europe; division A was importing 37 percent, division B 97 percent and division C 50 percent of their total throughput. The study was concerned only after the point of entry of goods in the United Kingdom. However it was possible to consider different arrival ports as alternatives to the existing ones.

9.2.2 Terms of Reference

The terms of reference which were agreed with the company were;

"To analyze the existing distribution strategy operation and costs of the company's three divisions in the UK; To identify feasible alternative strategies involving combined distribution operations and perform a cost evaluation of these using LSM; To discuss the alternatives with the company and then perform more detailed analysis, considering number of depots and their locations; To report the findings to the company."

9.2.3 Approach

The approach adopted in this case study was ;

"Collect and collate data on existing operations and costs; produce cost models of current operations; identify alternative strategies to the current operation. Evaluate the major alternatives using LSM. Present and discuss results."

Detailed studies of the transport and warehouse operations of each division were carried out to understand the difficulties which might be encountered in merging the total distribution system. The details of this work will not be given here because it is not directly relevant. The main results and conclusions were that there are some differences in approach and operations but that these are not sufficient to detract from the opportunities that a merged structure might provide.

9.2.3 Using LSM

To use any model it is essential to collect appropriate data to allow for the validation of the model to reflect the particular operation that is under review. The importance of validation and the data used to validate such models was discussed in the previous case study.

9.2.3.1 Data Collection

Divisions A and B provided the names, addresses and demands for their customers and their locations were identified from an Ordnance Survey grid reference map. For division C a strategic study had earlier been carried out and its customers demands and location data were available and converted to the required format. The appropriate fixed and variable costs were provided by each division for its local delivery, trunking, and distribution depots.

9.2.3.2 Validation of Model

The demand data provided by the company was based on an eight week period. This data was used to validate the model for each division separately. The eight weeks' costs were converted to 52 weeks cost for each component of the distribution system. The model-produced costs at the validation stage and the actual costs for each division of the company are given in figure 9.1b for division A, figure 9.2b for division B and figure 9.3b and 9.4b for division C. The model-produced cost is ± 2 percent of the actual cost. This is acceptable for a strategic study of this nature.

Division A Validation

	Throughput in M ³	Trunking Cost in £	Handling Cost in £	Local delivery Cost
Model	190,000	125,400	860,000	1,094,900
Actual	190,000	124,000	857,000	1,121,200
Variance	0 %	+1.1 %	1.0 %	-2.0

Figure 9.1b Validation chart for division A

Division B Validation

	Throughput in M ³	Trunking Cost in £	Handling Cost in £	Local delivery Cost
Model	107,500	0	469,700	1,269,100
Actual	107,000	0	470,000	1,121,400
Variance	-0.5 %	0%	+ 0.99%	-1.1%

Figure 9.2b Validation chart for division B

Division C Validation

	Throughput in M ³	Trunking Cost in £	Handling Cost in £	Local delivery Cost
Model	255,551	267,155	649,897	812,364
Actual	2,555,580	166,202	677,248	858,260
Variance	0 %	0%	-0.04%	-0.06

Figure 9.3b Validation chart for division C

Division C Validation

	Direct delivery cost in £	Site Cost in £	Total Cost in £
Actual	662,306	156,122	2,547,844
Model	667,316	116,272	2,585,388
Variance	0.01%	0.26%	-0.01 %

Figure 9.4b Validation chart for division C

9.2.4 Integrated Approach

The demand data for the three divisions were combined together and demand and source points are depicted in figure 9.5b. The direct delivery demand and source points are given in figure 9.6b. The direct delivery was modelled separately.

LSM is able to design and test different distribution network structures. Therefore each different option was first tested for the present distribution system and then, using the 1992 expected demands and cost functions, a distribution network was designed to satisfy the company's defined objective.

9.2.4.1 Central Depot Option

As described in the previous case study, the central depot has the advantage of having all stocks and administration at one location. By using the combined data for the three divisions, the central depot option was tested. The depot was located in a central position and then its least cost location was found by using LSM's visually interactive best location searching

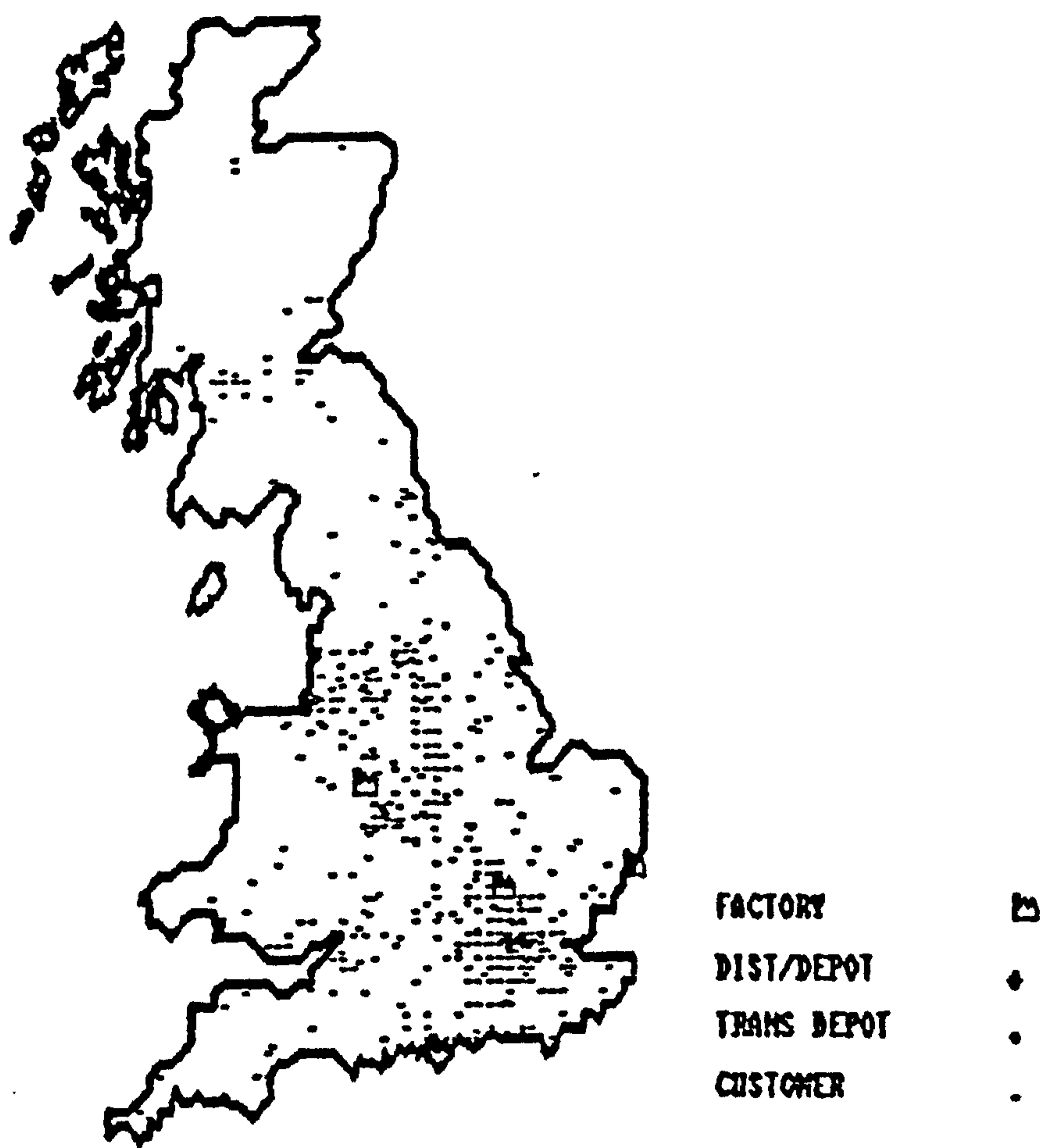

Figure 9.5b

Source & demand points for 1988

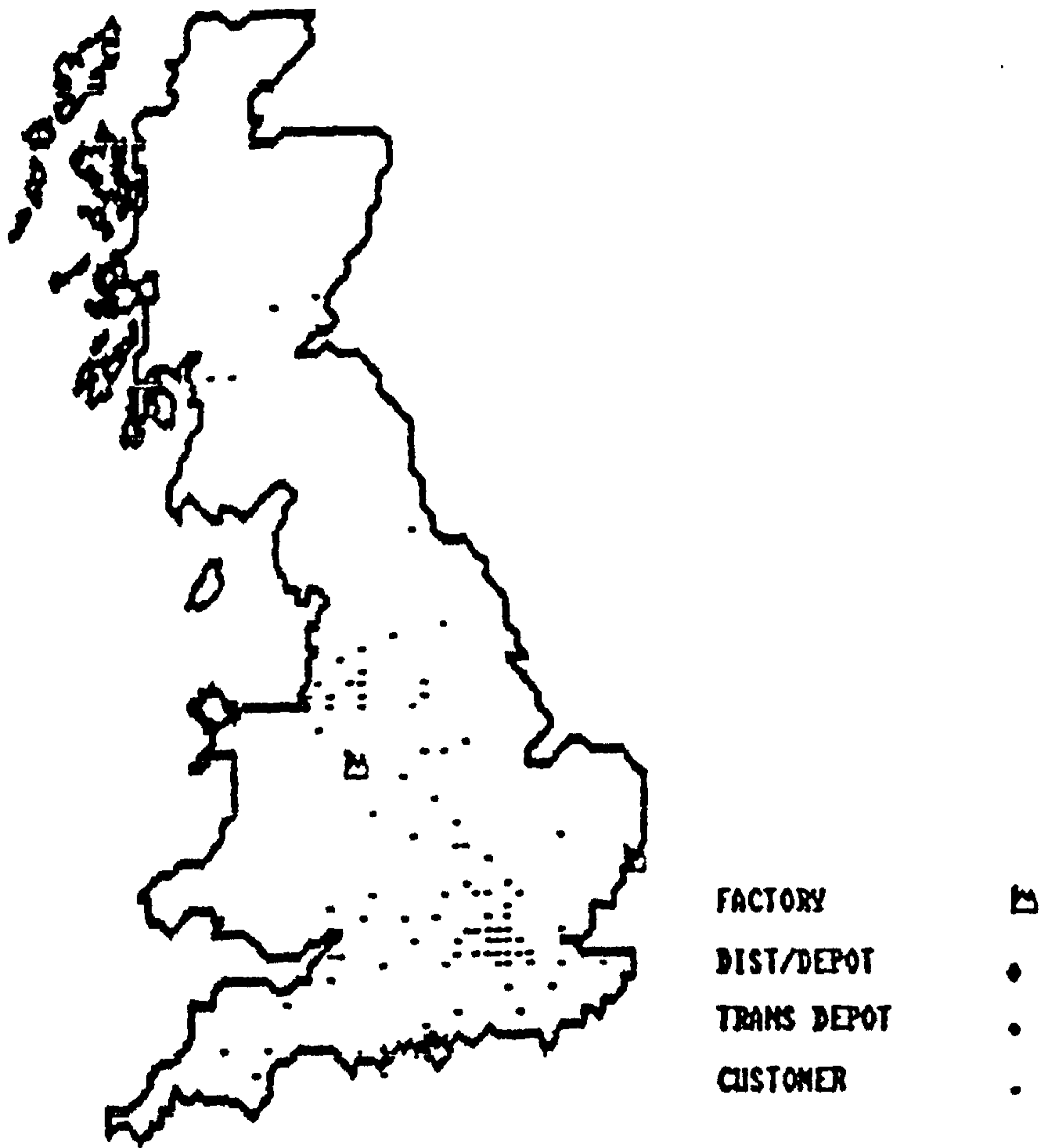

Figure 9.6b Source & demand points for 1988
(direct delivery)

function. The LSM-found location and its associated cost and distribution network structures are depicted in figure 9.7b. The outside line shows the delivery area of the depot. The lines from plants to depot show the flow of product from source points to distribution depot.

The local delivery cost (delivery from depot to customer, sometimes also known as outbound delivery cost) is significantly higher than the trunking cost. A logical next step would be to introduce a transshipment point to reduce the local delivery cost. LSM is able to model a logistic system which includes transshipment points and distribution depots. A transshipment point was added outside Glasgow and the LSM best location function was employed to find the best possible location for the depot and transshipment point. The resulting distribution network structure and the cost for each component of the distribution system is depicted in figure 9.8b.

The boundary lines clearly show the area which is being served by the distribution depot and transshipment point. The total distribution cost was down by 15 percent. This clearly confirmed that a one depot and one transshipment point distribution network is cheaper than having a central depot. To measure the impact of adding another transshipment point to the system, a transshipment point was added in the south west of England and best location search function was utilised. The resulting solution is depicted in figure 9.9b. The line between depot to transshipment point is broad because it shows the volume of product to each transshipment point. The cost is further reduced by three percent.

9.2.4.2 Two Depots Option

One of the main advantages of modelling a distribution system on computer is the ability to test many different strategies. The next series of options therefore concerned the company having two distribution depots for its distribution system. These were tested by using LSM. One depot was located at the UK plant site and the other on a best location place found by using the

DATE = 3 6 1989
 TIME = 17 55 18



OPTIMIZE DEPOT LOCATIONS
 MODIFY DATA
 MANUALLY ALLOCATE DEPOTS
 DISPLAY COST/ALLOCATION DATA
 RESTART ALLOCATION
 ZOOM IN
 PRINT SCREEN
 QUIT

LOCAL/DEL = 32277
 LOCAL/TRUCK = 8
 TRUCKING = 5424
 DIS/CENTRE = 14955
 TOTAL COST = 52717

FACTORY 2
 DIST/DEPOT .
 TRANS DEPOT .
 CUSTOMER .

Figure 9.7b

Central depot option

DATE = 3 6 1989
 TIME = 17 59 32

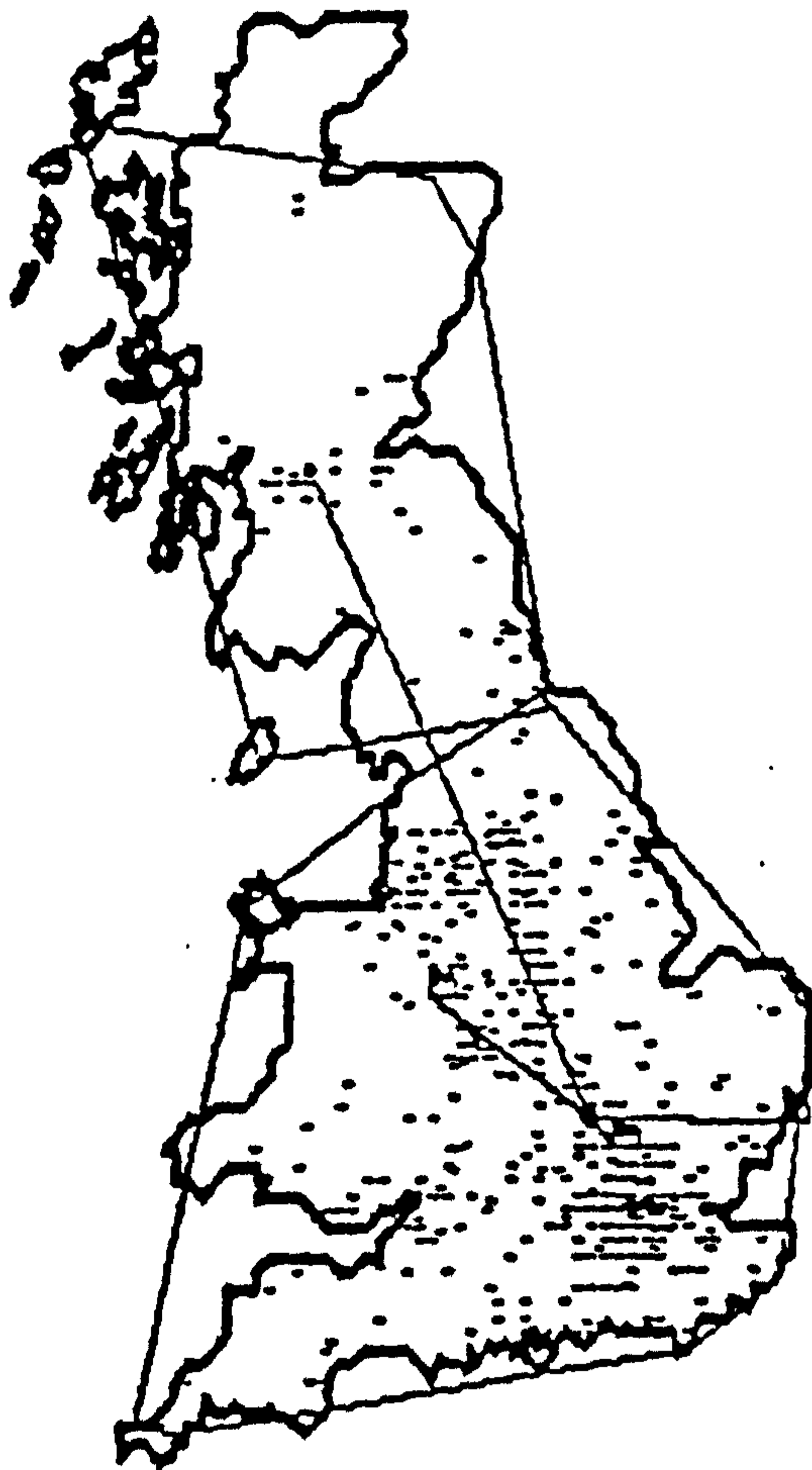

OPTIMISE DEPOT LOCATIONS
 MODIFY DATA
 MANUALLY ALLOCATE DEPOTS
 DISPLAY COST/ALLOCATION DATA
 RESTART ALLOCATION
 ZOOM IN
 PRINT SCREEN
 QUIT

LOCAL/DEL = 23183
 LOCAL/TRUNK = 1526
 TRUNKING = 4684
 DIS/CENTRE = 15794
 TOTAL COST = 45827

FACTORY
 DIST/DEPOT
 TRANS DEPOT
 CUSTOMER

Figure 9.8b

Central depot

Scottish transshipment point

DATE = 3 6 1989
 TIME = 18 3 31



OPTIMISE DEPOT LOCATIONS
 MODIFY DATA
 MANUALLY ALLOCATE DEPOTS
 DISPLAY COST/ALLOCATION DATA
 RESTART ALLOCATION
 ZOOM IN
 PRINT SCREEN
 QUIT

LOCAL/DEL = 28729
 LOCAL/TRUNK = 1978
 TRUNKING = 3965
 DIS/CENTRE = 16623
 TOTAL COST = 43288

FACTORY M
 DIST/DEPOT •
 TRANS DEPOT •
 CUSTOMER •

Figure 9.9b Central depot and
 Scottish & Bristol
 transshipment points

LSM best location search function. As previously indicated, LSM is able to design a distribution network which is based on some depots with fixed locations and others located at their least-cost location. This function is very useful in a study where some depots are permanent, such as factory site depots, or where a company only wishes to investigate a part of its distribution system.

The resulting distribution structure designed through using the above function and its associated cost is depicted in figure 9.10b. This solution is better even than the one depot and two transshipment points solution. As in the previous case, to reduce the local delivery cost, a transshipment point was added and the best location search function was used to find the best possible locations for the depots and transshipment points in their serving areas. The resulting structure is depicted in figure 9.11b.

The local trunking cost (the cost between depot and transshipment point) was increased but local delivery cost was reduced significantly. The total cost was reduced by 16 percent compared to the two depots solution. To test the impact on total cost, another transshipment point was added in the south west of England and the searching function was used to find the best location. The resulting solution is given in figure 9.12b. The cost was further reduced by 6 percent compared to the previous solution. This solution is the cheapest amongst all the previously designed distribution network solution.

9.2.4.3 Three depots Option

LSM was also used to test a three-depot distribution network. The three depots were initially situated in the best locations determined by observing the geographical distribution of the customers on the screen. LSM has a clear advantage here over non-visually interactive distribution models.

To add a depot into a particular location is always a crucial choice in distribution systems modelling. LSM displays all the customers in their



OPTIMISE DEPOT LOCATIONS
 MODIFY DATA
 MANUALLY ALLOCATE DEPOTS
 DISPLAY COST/ALLOCATION DATA
 RESTART ALLOCATION
 ZOOM IN
 PRINT SCREEN
 QUIT

LOCAL/DEL = 21983
 LOCAL/TRUNK = 0
 TRUNKING = 9848
 DIS/CENTRE = 6955
 TOTAL COST = 38698

FACTORY
 DIST/DEPOT
 TRANS DEPOT
 CUSTOMER

Figure 9.10b 2 Depots option

DATE = 3 6 1989
 TIME = 18 15 38

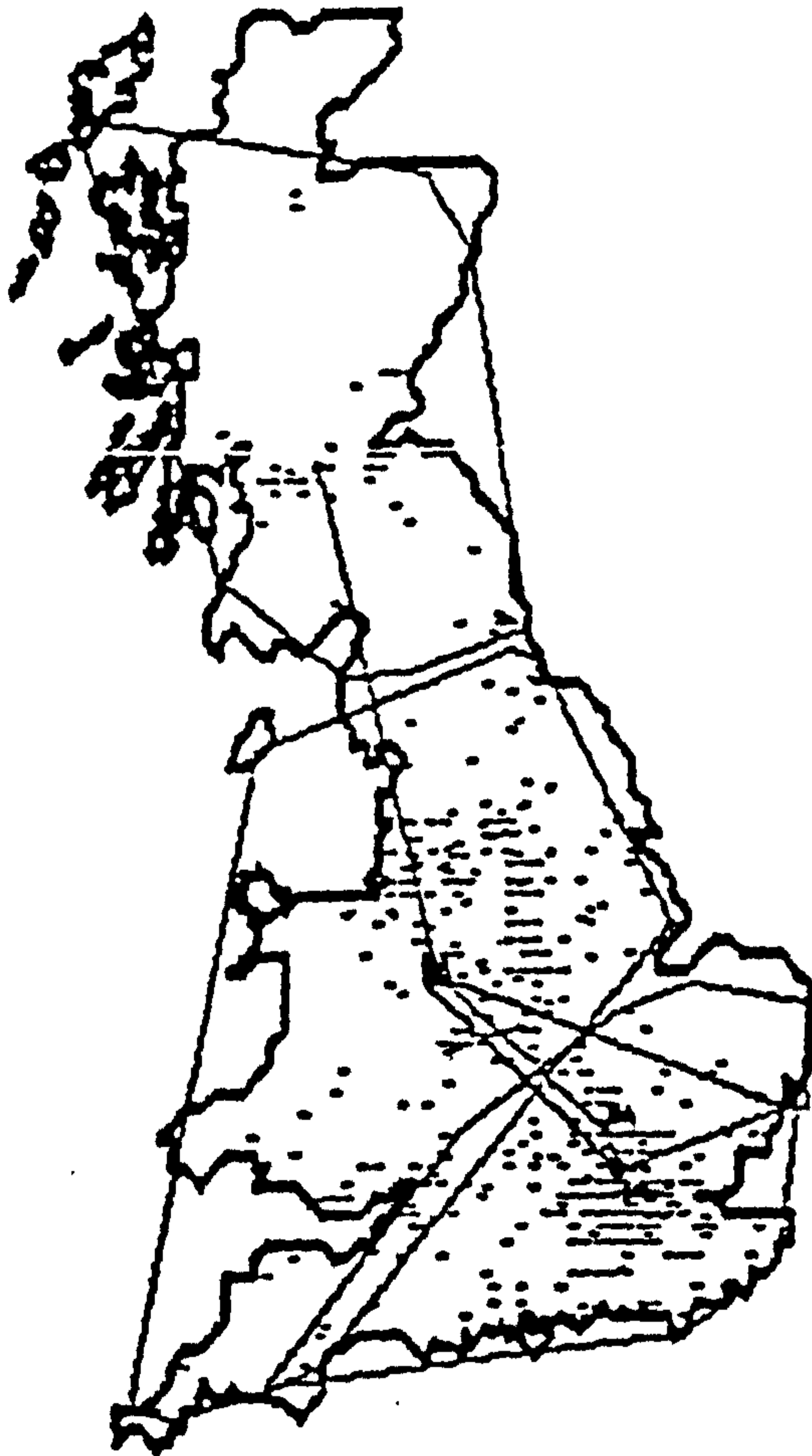

OPTIMISE DEPOT LOCATIONS
 MODIFY DATA
 MANUALLY ALLOCATE DEPOTS
 DISPLAY COST/ALLOCATION DATA
 RESTART ALLOCATION
 ZOOM IN
 PRINT SCREEN
 QUIT

LOCAL/DEL = 15582
 LOCAL/TRANS = 1838
 TRUCKING = 8114
 DIS/CENTRE = 7737
 TOTAL COST = 32383

FACTORY E
 DIST/DEPOT •
 TRANS DEPOT •
 CUSTOMER .

Figure 9.11b 2 Depots and
 Scottish transshipment point

DATE = 3 6 1989
 TIME =18 20 16

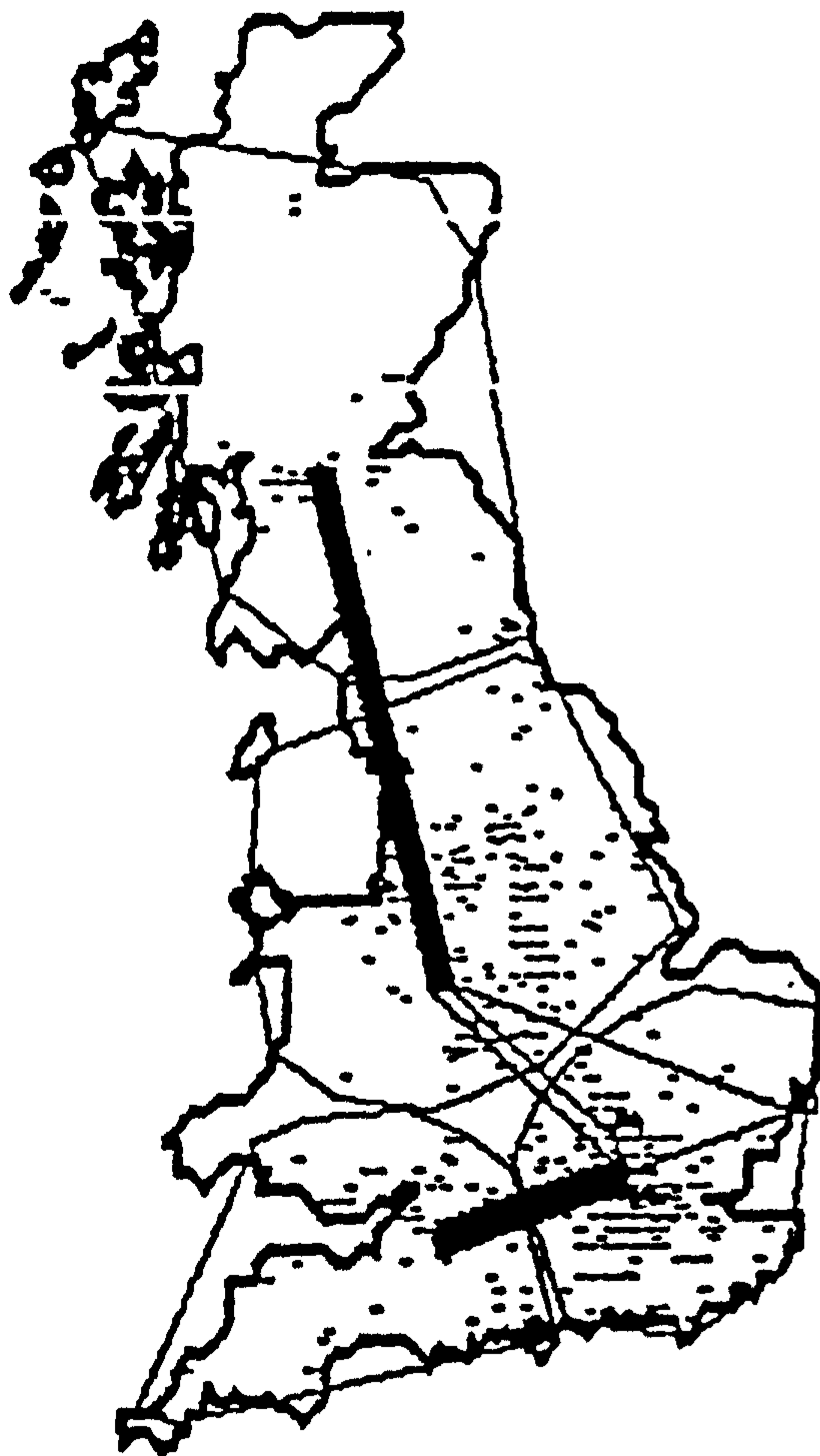

OPTIMISE DEPOT LOCATIONS
 MODIFY DATA
 MANUALLY ALLOCATE DEPOTS
 DISPLAY COST/ALLOCATION DATA
 DEPTANT ALLOCATION
 REGIONAL ALLOCATION
 ZOOM IN
 PRINT SCREEN
 QUIT

LOCAL/DEL = 13641
 LOCAL/TRUNK = 1489
 TRUNKING = 6813
 DIS/CENTRE = 8465
 TOTAL COST= 38329

FACTORY M
 DIST/DEPOT •
 TRANS DEPOT •
 CUSTOMER .

Figure 9.12b 2 depots and
 Scottish & Bristol
 transshipment points

geographical location on the screen and this can be very helpful when trying to determine initial locations.

The best search function was used to search the best location place for all the depots and the resulting solution and its associated costs is given in figure 9.13b. This solution is not cheaper than the previous solution. Therefore the three depots option was not investigated any further.

9.2.4.4 Summary

The total cost was plotted against the number of depots in the total system and is shown in figure 9.14b. The different costs are plotted against the number of depots in figure 9.15b. The overall cost structure follows the cost derivations identified from the literature search in chapter two. The conclusion drawn from the above study for the company is that the two depots and two transshipment points option is the best option for its combined distribution network structure.

9.2.5 1992 Options

The next stage in the modelling process was to design the distribution strategy for 1992. According to the company's forecast, the demand for each division will be increased as depicted in figure 9.16b.

A new customer demand database file was prepared by increasing demand and drops for each division using the factor depicted in figure 9.16b for 1992. There were also some other factors such as a change in the local delivery and direct delivery ratio. The overall ratio was altered from 35:65 to 50:50. The European mainland goods arrival point was changed from Kent to East Anglia and Newhaven. The new source points and demand areas are depicted in figure 9.17b for the system to be modelled by LSM and 9.18b for the direct delivery system.

DATE = 3 6 1989
TIME = 19 28 40



OPTIMISE DEPOT LOCATIONS
MODIFY DATA
MANUALLY ALLOCATE DEPOTS
DISPLAY COST/ALLOCATION DATA
RESTART ALLOCATION
ZOOM IN
PRINT SCREEN
QUIT

LOCAL/DEL = 28128
LOCAL/TRUNK = 8
TRUNKING = 11421
DIS/CENTRE = 7955
TOTAL COST = 39584





FACTORY 
DIST/DEPOT 
TRANS DEPOT 
CUSTOMER 

Figure 9.13b

3 Depots options

Number of Depots Vs Cost

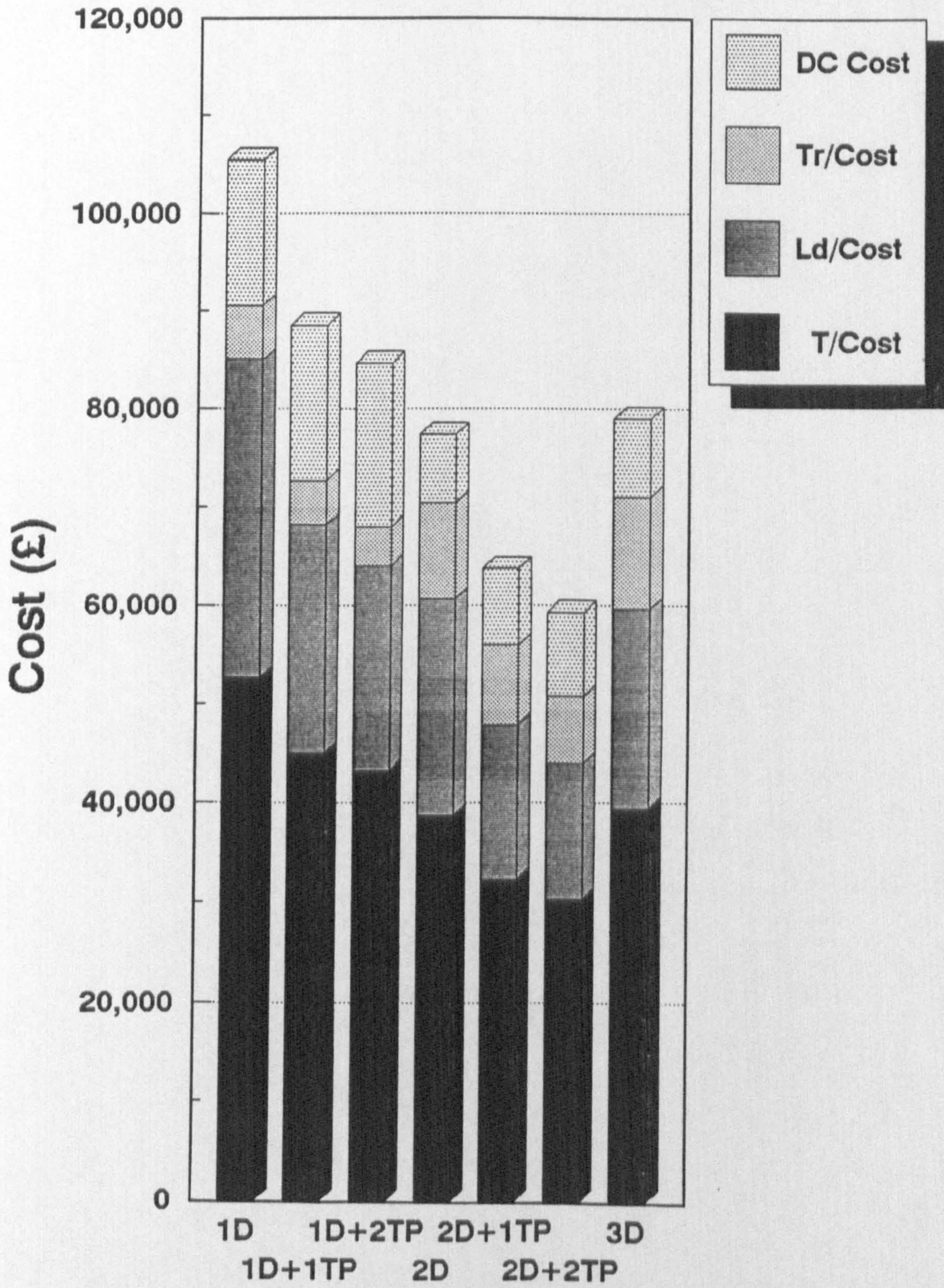

Fig9.14b Number of Depots

Number of Depots Vs Cost

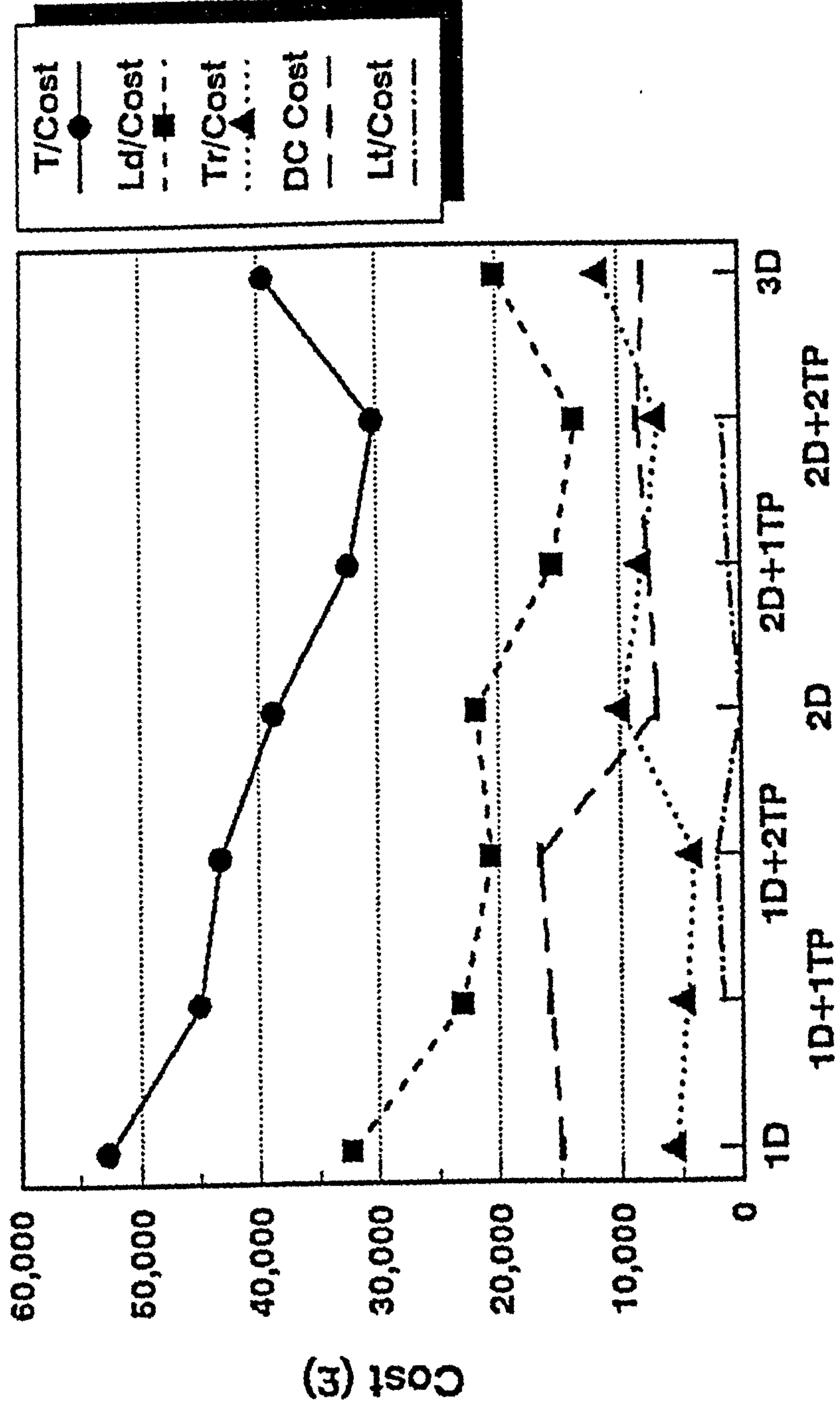

Figure 9.15b Number of Depots

Expacted demand increase for 1992

Divisions	Volume % increase	Drops % increase
A	15	15
B	10	3
C	2.5	15

Figure 9.16b

The previously designed distribution strategy does not guarantee the best solution because some of the parameters on which previous solutions were derived have been changed. Therefore using the new demand data, new source point location and expected distribution costs, LSM was used to design a new distribution strategy to satisfy the company's objectives for 1992.

9.2.5.1 Central Depot Options

As before the distribution network design began with one distribution depot. The distribution depot was located at a central position by using the LSM best location search function. The resulting distribution structure and its associated costs are depicted in figure 9.19b. From the previous study some lessons were learned and two transshipment points were added, one at Bristol and the other at Glasgow. The best search location function was used for whole system and the resulting solution is depicted in figure 9.20b. The total cost of the distribution network system was reduced by 23 percent compared to the one depot solution. If a comparison is made between these two options, then a two transshipment point and a one depot option is cheaper than the one central depot option. But this will be a partial solution.

9.2.5.2 Two Depots Options

The next stage was to test a distribution network which consisted of two depots located at the best possible locations, which LSM is able to find by using its searching function. The resulting solution is depicted in figure 9.21b.

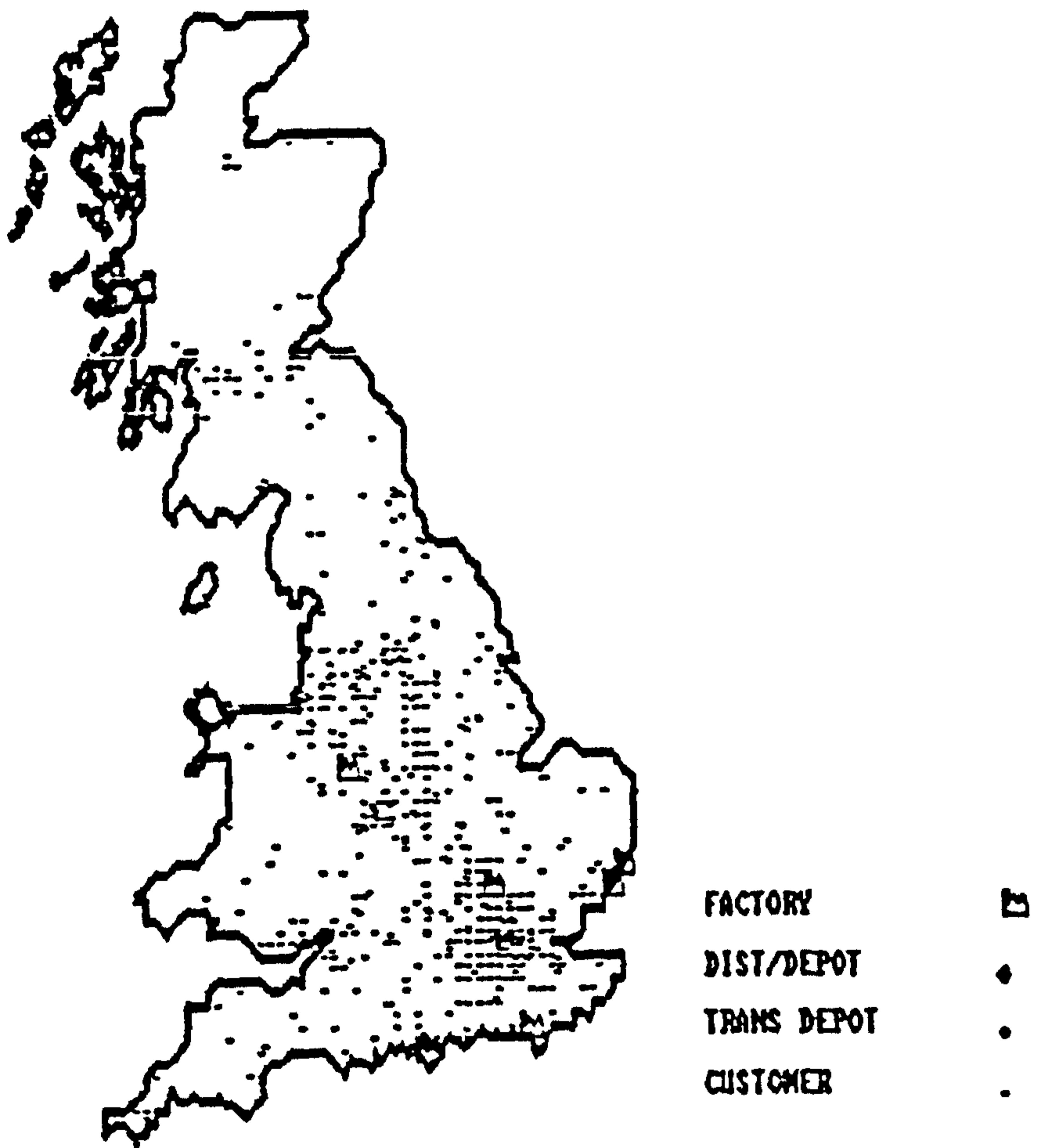

Figure 9.17b

Source & demand points for 1992

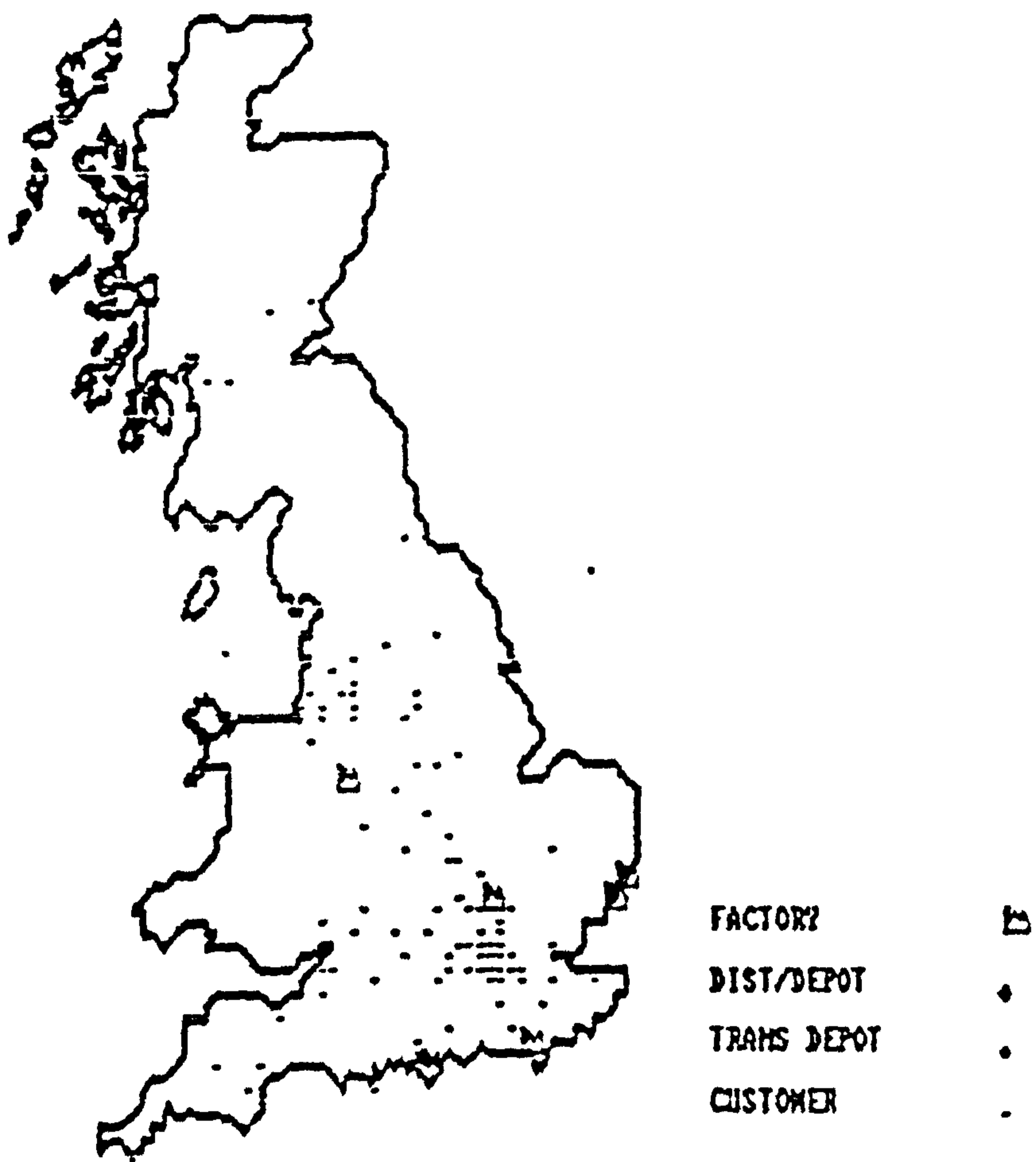
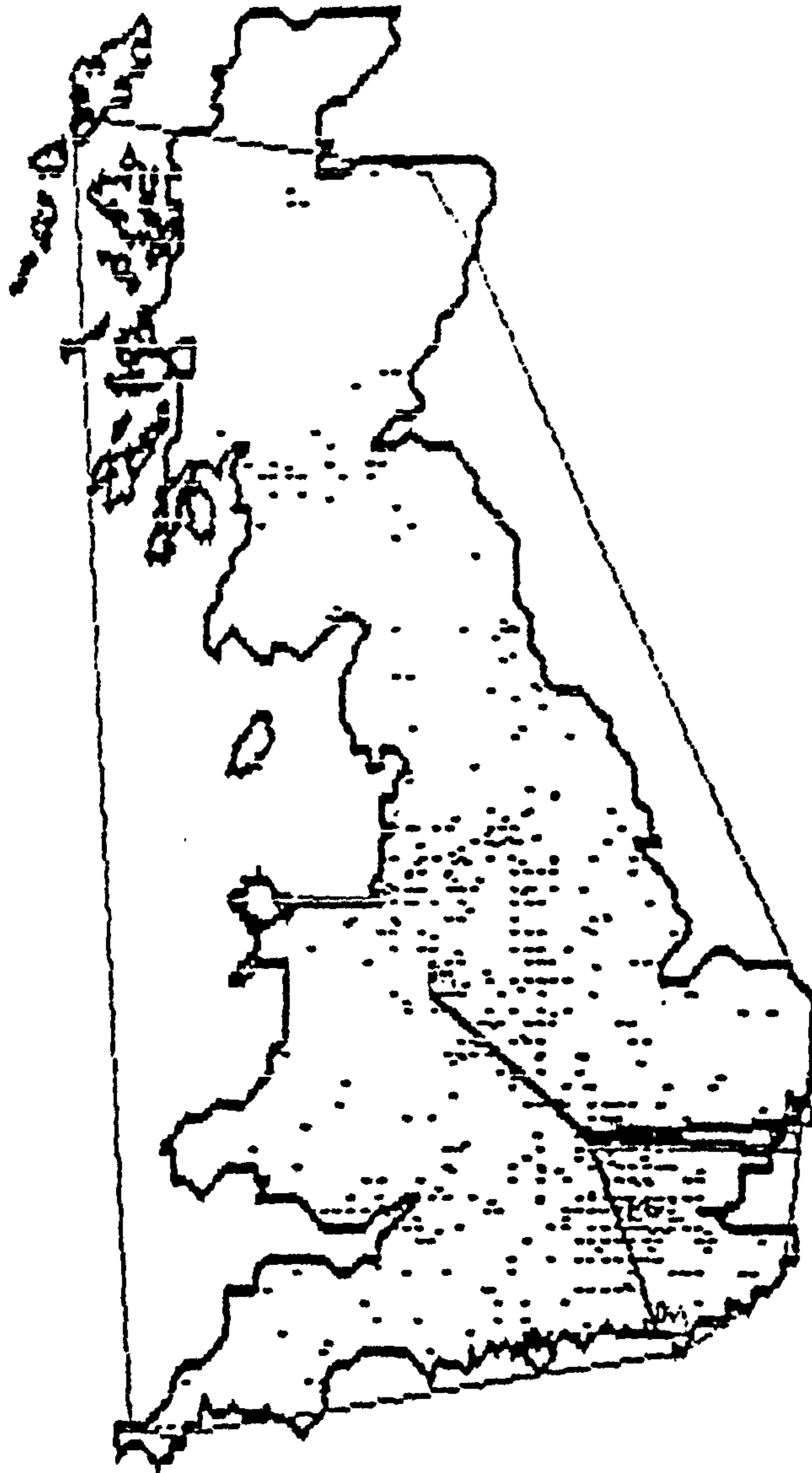

Figure 9.18b

Source & demand points for 1992
(direct delivery)

DATE =10 6 1989
 TIME =16 41 18



OPTIMISE DEPOT LOCATIONS
 MODIFY DATA
 MANUAL ALLOCATION
 DISPLAY COST/ALLOCATION DATA
 RESTART ALLOCATION
 ZOOM IN
 PRINT SCREEN
 PRINT INPUT DATA
 QUIT

LOCAL/DEL = 87552
 LOCAL/TRUNK = 0
 TRUNKING = 11241
 DIS/CENTRE = 17846
 TOTAL COST= 115838

FACTORY
 DIST/DEPOT
 TRANS DEPOT
 CUSTOMER

Figure 9.19b Central depot
 (best possible location)

OPTIMISE DEPOT LOCATIONS
 MODIFY DATA
 MANUAL ALLOCATION
 DISPLAY COST ALLOCATION DATA
 RESTART ALLOCATION
 ZOOM IN
 PRINT SCREEN
 PRINT INPUT DATA
 QUIT

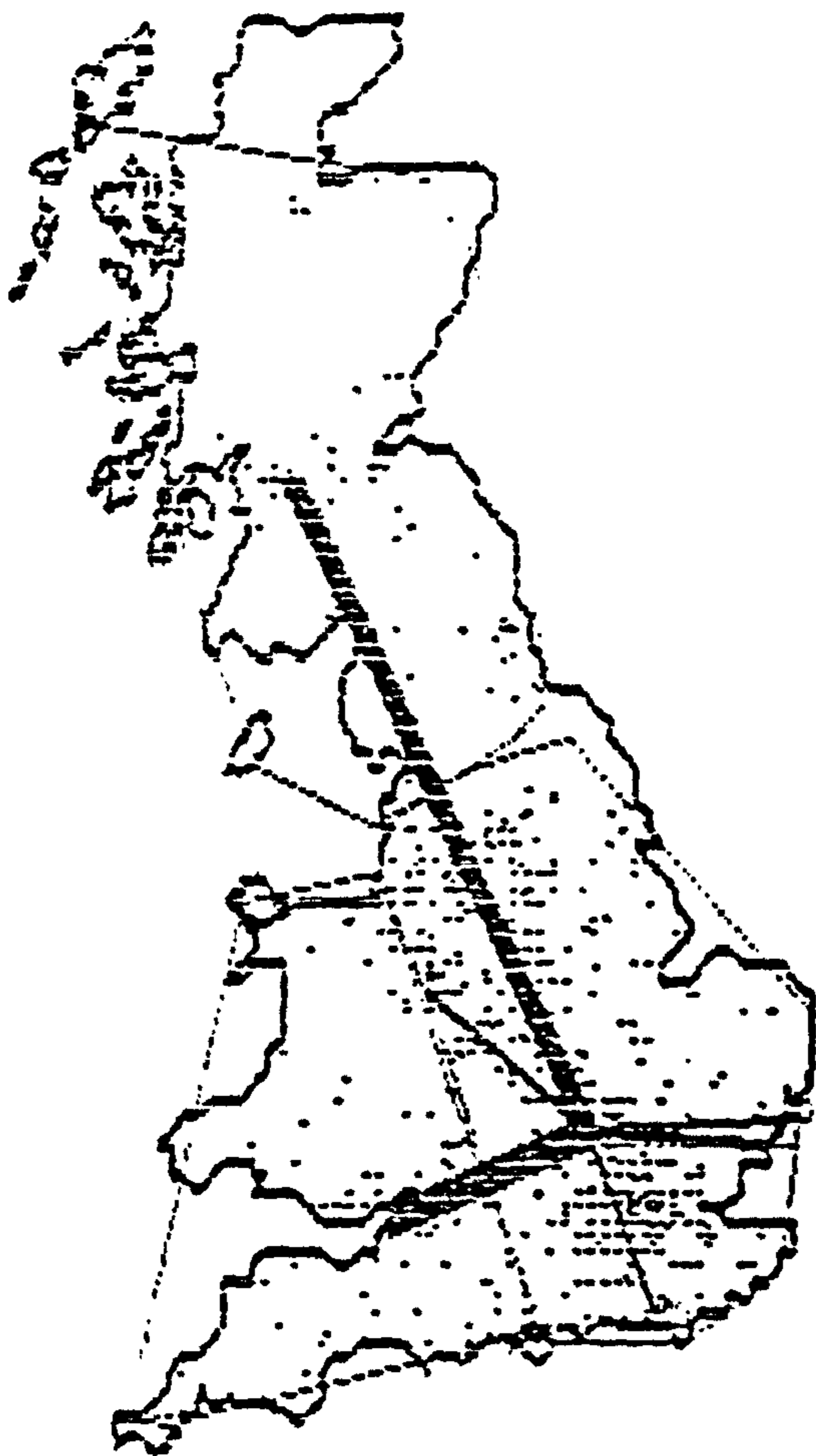

OPTIMISE DEPOT LOCATIONS
 MODIFY DATA
 MANUAL ALLOCATION
 DISPLAY COST ALLOCATION DATA
 RESTART ALLOCATION
 ZOOM IN
 PRINT SCREEN
 PRINT INPUT DATA
 QUIT

LOCAL/DEL = 55091
 LOCAL/TRUNK = 4999
 TRUNKING = 11296
 DIS/CENTRE = 17858
 TOTAL COST = 89244

FACTORY ■
 DIST/DEPOT ◆
 TRANS DEPOT ●
 CUSTOMER .

Figure 9.20b Central depot and
 Scottish & Bristol
 transshipment points
 (best possible location)

DATE =10 6 1989
TIME =14 39 47

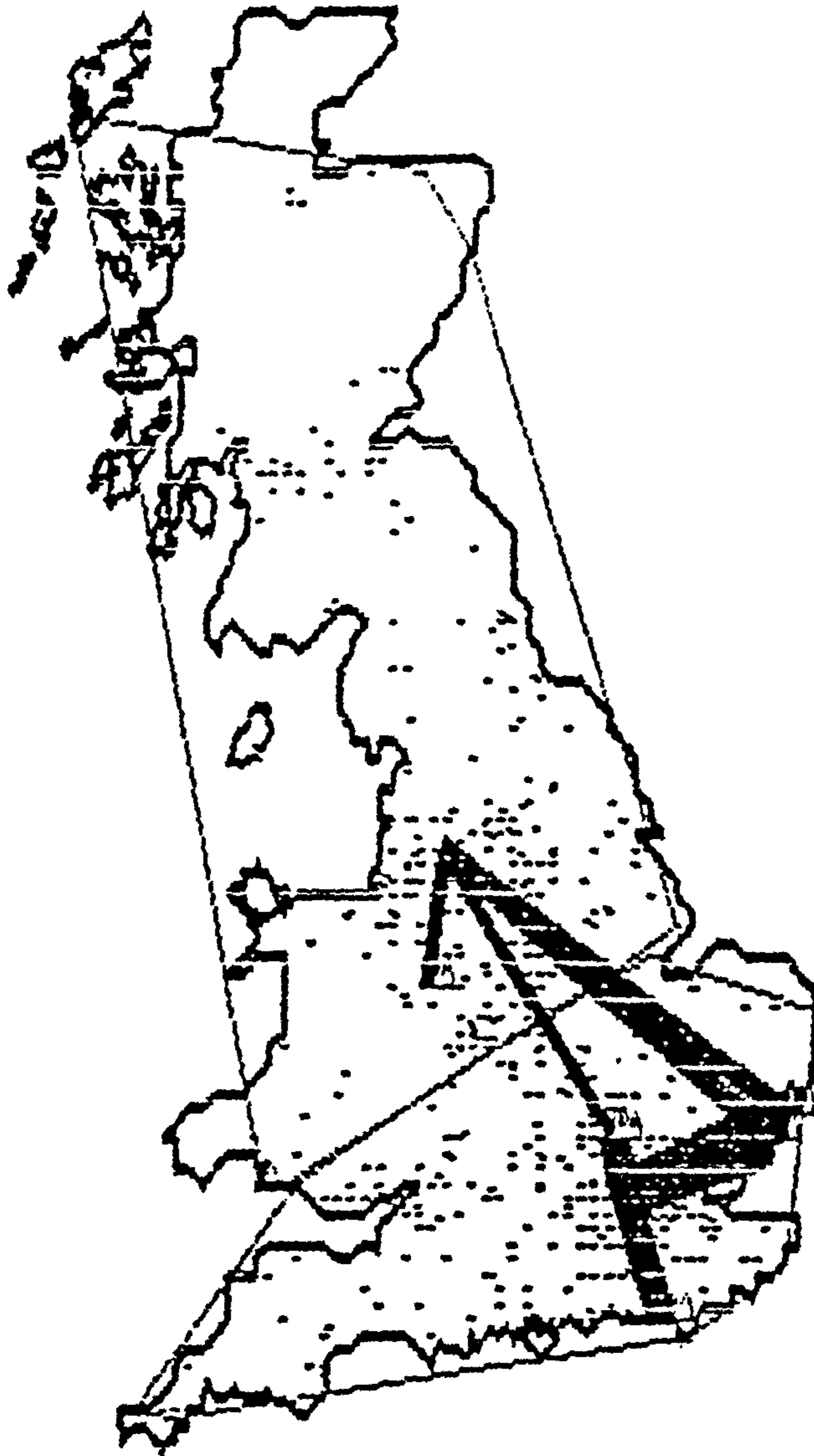

OPTIMISE DEPOT LOCATIONS
MODIFY DATA
MANUAL ALLOCATION
DISPLAY COST/ALLOCATION DATA
RESTART ALLOCATION
ZOOM IN
PRINT SCREEN
PRINT INPUT DATA
QUIT

LOCAL/DEL = 54908
LOCAL/TRUNK = 8
TRUNKING = 12476
DIS/CENTRE = 22346
TOTAL COST= 89722

FACTORY
DIST/DEPOT
TRANS DEPOT
CUSTOMER

Figure 9.21b 2 Depots
(best possible location)

This solution is slightly more expensive than the one depot and two transshipment points solution as is shown in figure 9.20b. To take advantage of cheaper trunking cost compared to local delivery costs, a transshipment point was added at Glasgow. Then, using LSM best location search function, it was moved to the cheapest location in the area. The resulting solution and associated cost is depicted in figure 9.22b. The second transshipment point was added in the south west and the resulting solution is given in figure 9.23b. The best location search function was used for all the depots and transshipment points in the distribution system and the derived distribution network and associated cost is depicted in figure 9.24b.

Adding one transshipment point at Glasgow to the two depots solution resulted in a cost reduction of 11 percent. Adding another transshipment point at Bristol further reduced costs by 6 percent. This clearly shows the advantages for the company of having two transshipment points. When LSM's best location search function was used to find the best possible location for the whole network structure, it resulted in a further cost reduction of 2 percent. This demonstrated the advantage of having the search function in a distribution model. The models reviewed in chapter five do not have this function.

9.2.5.3 Three depots Options

LSM does not determine the minimum number of depots required for a distribution network structure. Thus additional runs are required to test the effect of having more than two depots. A three depot distribution system was tested next. The three depots were located by using previous modelling experience of the same system and then the LSM best location search function was used to find the best possible locations. The resulting solution and its associated costs are given in figure 9.25b. In previous cases adding a transshipment point reduced the total system cost. Therefore a transshipment point was added at Bristol and the resulting distribution network and its associated costs are depicted in figure 9.26b. The best

DATE =10 6 1989
TIME =14 58 3

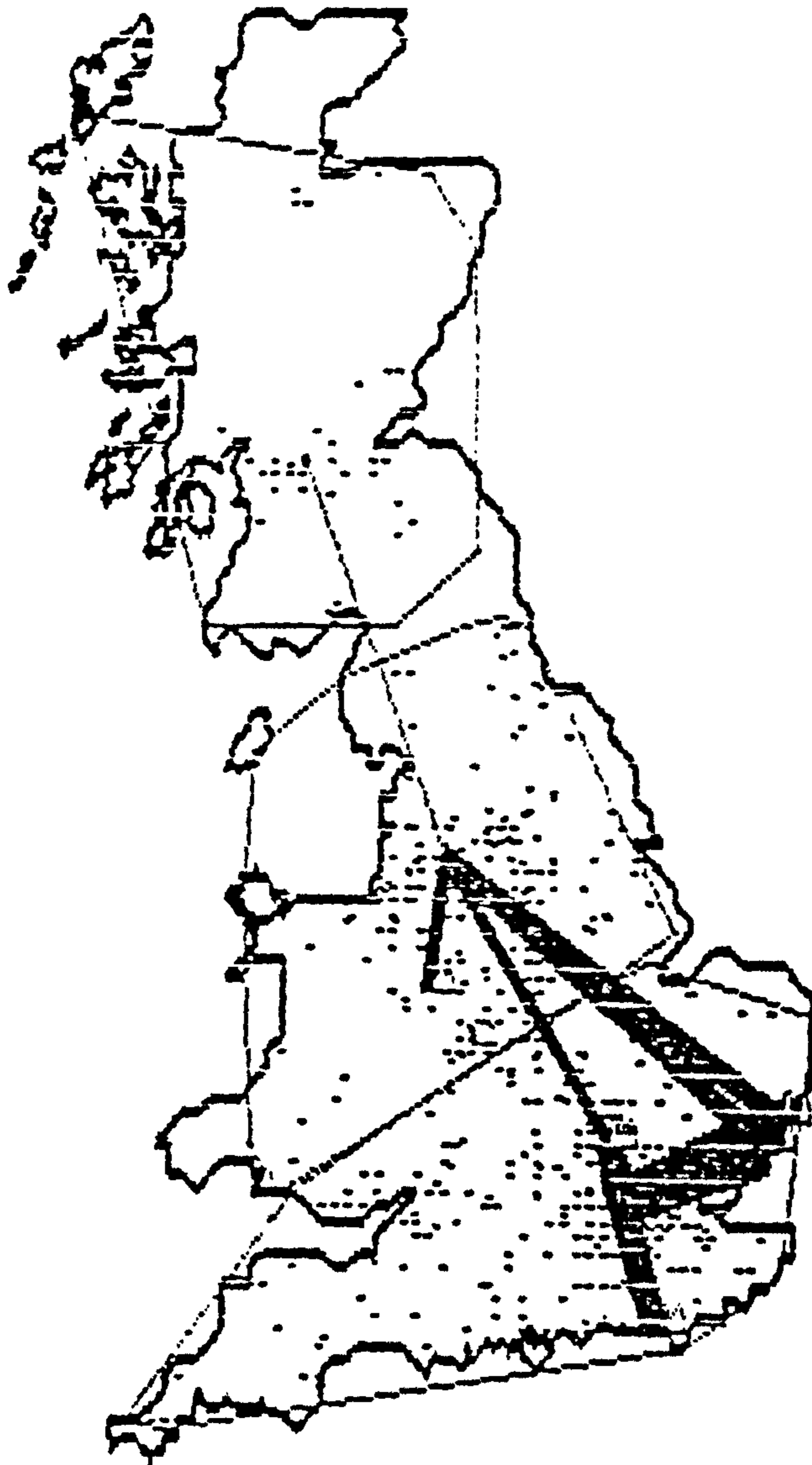

OPTIMISE DEPOT LOCATIONS
 MODIFY DATA
 MANUAL ALLOCATION
 DISPLAY COST/ALLOCATION DATA
 RESTART ALLOCATION
 ZOOM IN
 PRINT SCREEN
 PRINT INPUT DATA
 QUIT

LOCAL/DEL = 42788
 LOCAL/TRUNK = 1746
 TRUNKING = 12476
 DIS/CENTRE = 22786
 TOTAL COST= 79716

FACTORY
 DIST/DEPOT
 TRANS DEPOT
 CUSTOMER

Figure 9.22b 2 Depots
 (best possible location)
 Scottish transshipment point

DATE =10 00 1989
 TIME =15 26

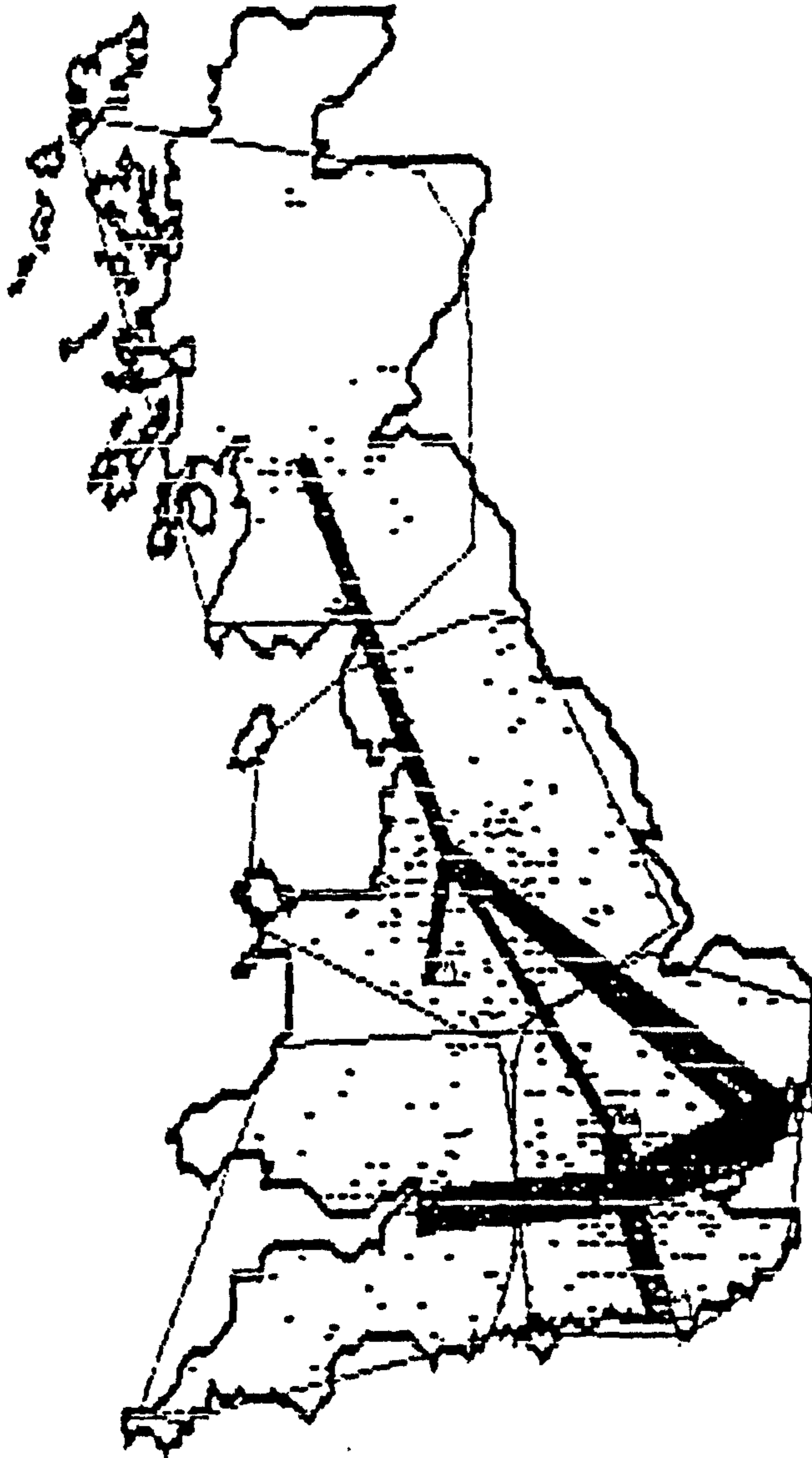

OPTIMISE DEPOT LOCATIONS
 MODIFY DATA
 MANUAL ALLOCATION
 DISPLAY COST/ALLOCATION DATA
 RESTART ALLOCATION
 ZOOM IN
 PRINT SCREEN
 PRINT INPUT DATA
 QUIT

LOCAL/DEL = 36139
 LOCAL/TRUNK = 3221
 TRUNKING = 12390
 DIS/CENTRE = 23081
 TOTAL COST= 74831

FACTORY
 DIST/DEPOT
 TRANS DEPOT
 CUSTOMER

Figure 9.23b 2 depots (best possible location)
 Scottish & Bristol
 transshipment points

DATE =10 6 1989
 TIME =15 17 29

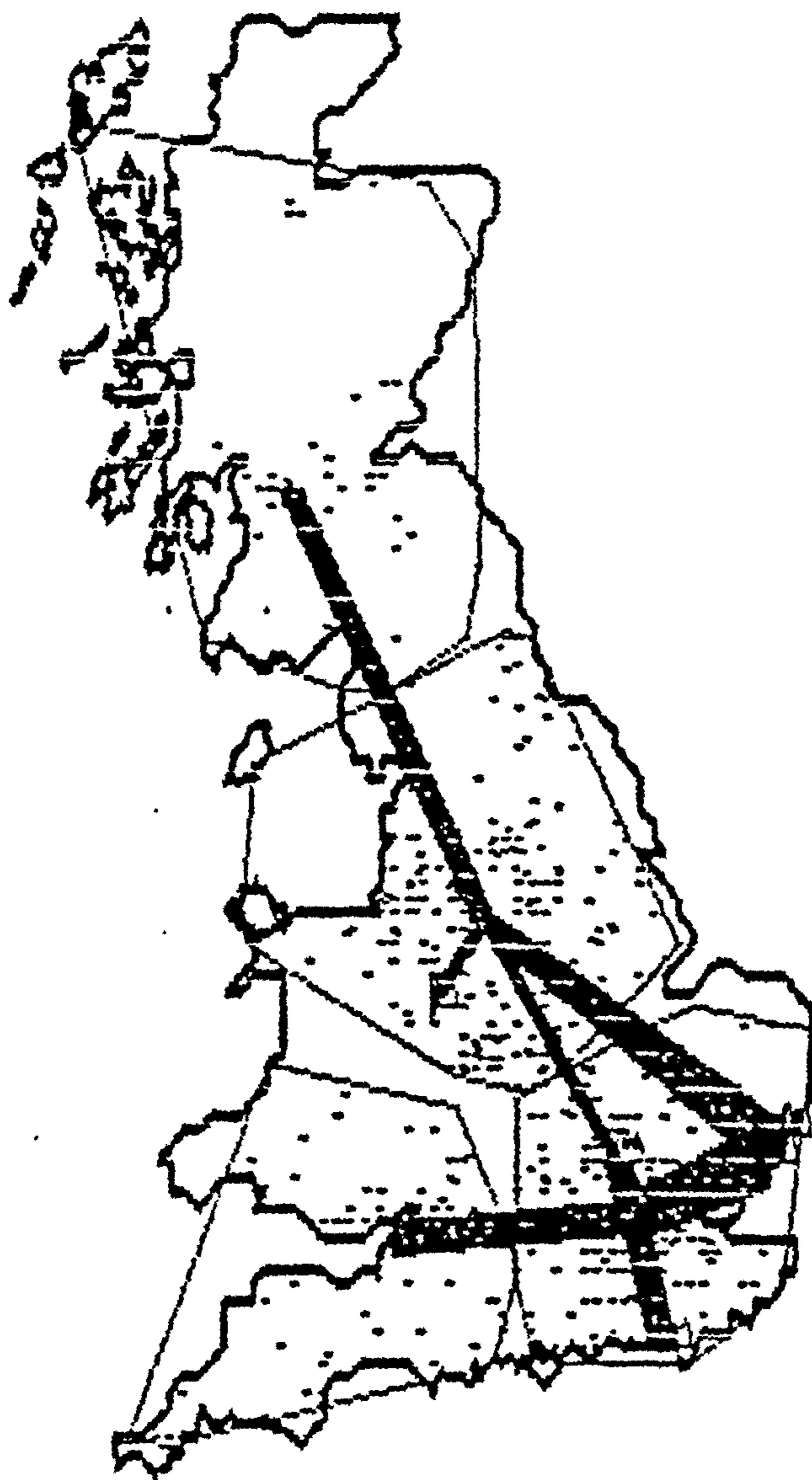

OPTIMISE DEPOT LOCATIONS
 MODIFY DATA
 MANUAL ALLOCATION
 DISPLAY COST/ALLOCATION DATA
 RESTART ALLOCATION
 ZOOM IN
 PRINT SCREEN
 PRINT INPUT DATA
 QUIT

LOCAL/DEL = 34756
 LOCAL/TRUNK = 3277
 TRUNKING = 12855
 DIS/CENTRE = 23864
 TOTAL COST= 73151

FACTORY
 DIST/DEPOT
 TRANS DEPOT
 CUSTOMER

Figure 9.24b 2 depots
 Scottish & Bristol
 transshipment points
 (best possible location)

DATE =10 6 1989
TIME =17 13 25

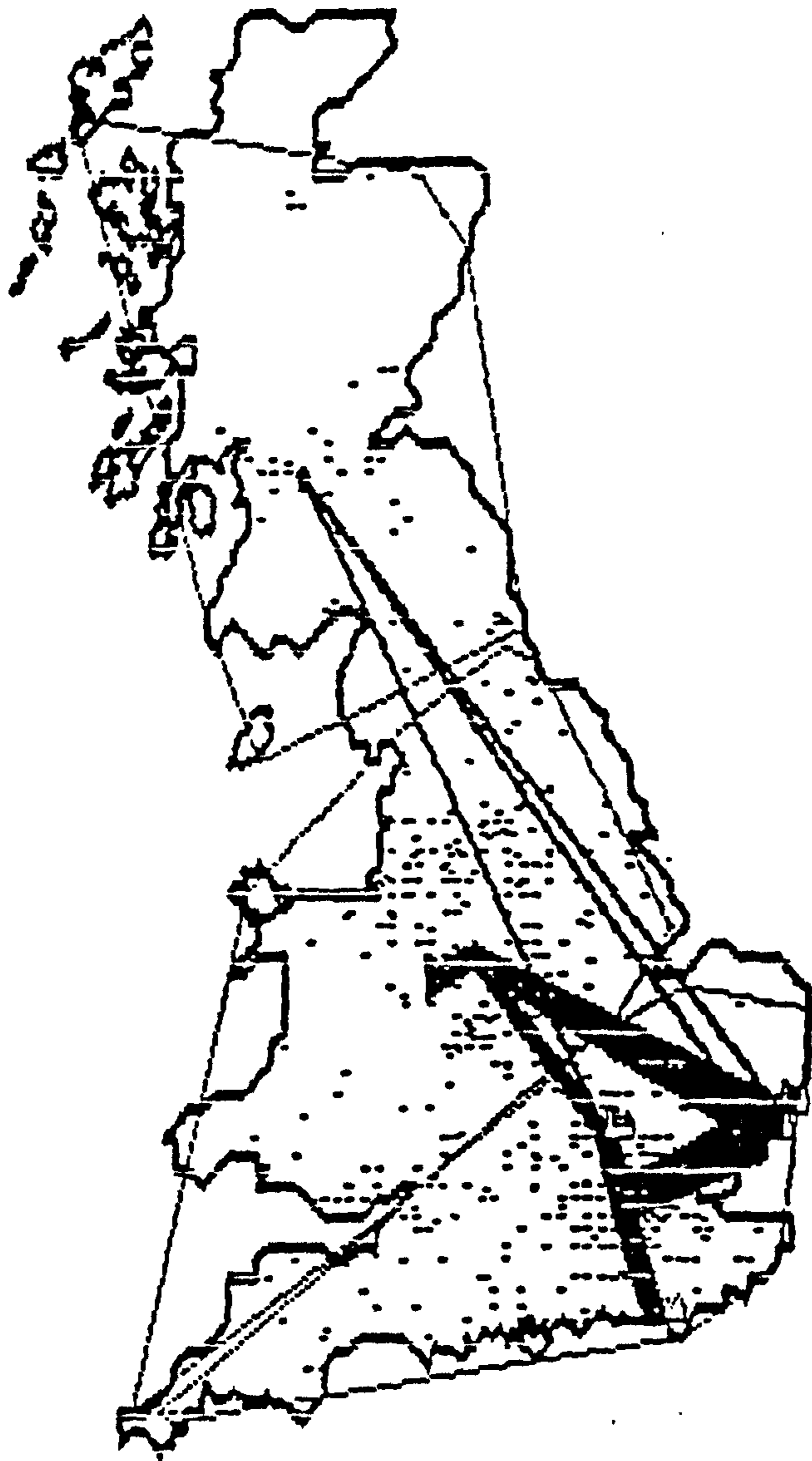

OPTIMISE DEPOT LOCATIONS
MODIFY DATA
MANUAL ALLOCATION
DISPLAY COST/ALLOCATION DATA
RESTART ALLOCATION
ZOOM IN
PRINT SCREEN
PRINT INPUT DATA
QUIT

LOCAL/DEL = 41540
LOCAL/TRUNK = 0
TRUNKING = 13261
DIS/CENTRE = 24646
TOTAL COST= 79447

FACTORY
DIST/DEPOT
TRANS DEPOT
CUSTOMER

Figure 9.25b 3 Depots options
(best possible location)

DATE =10 6 1989
 TIME =17 17 6

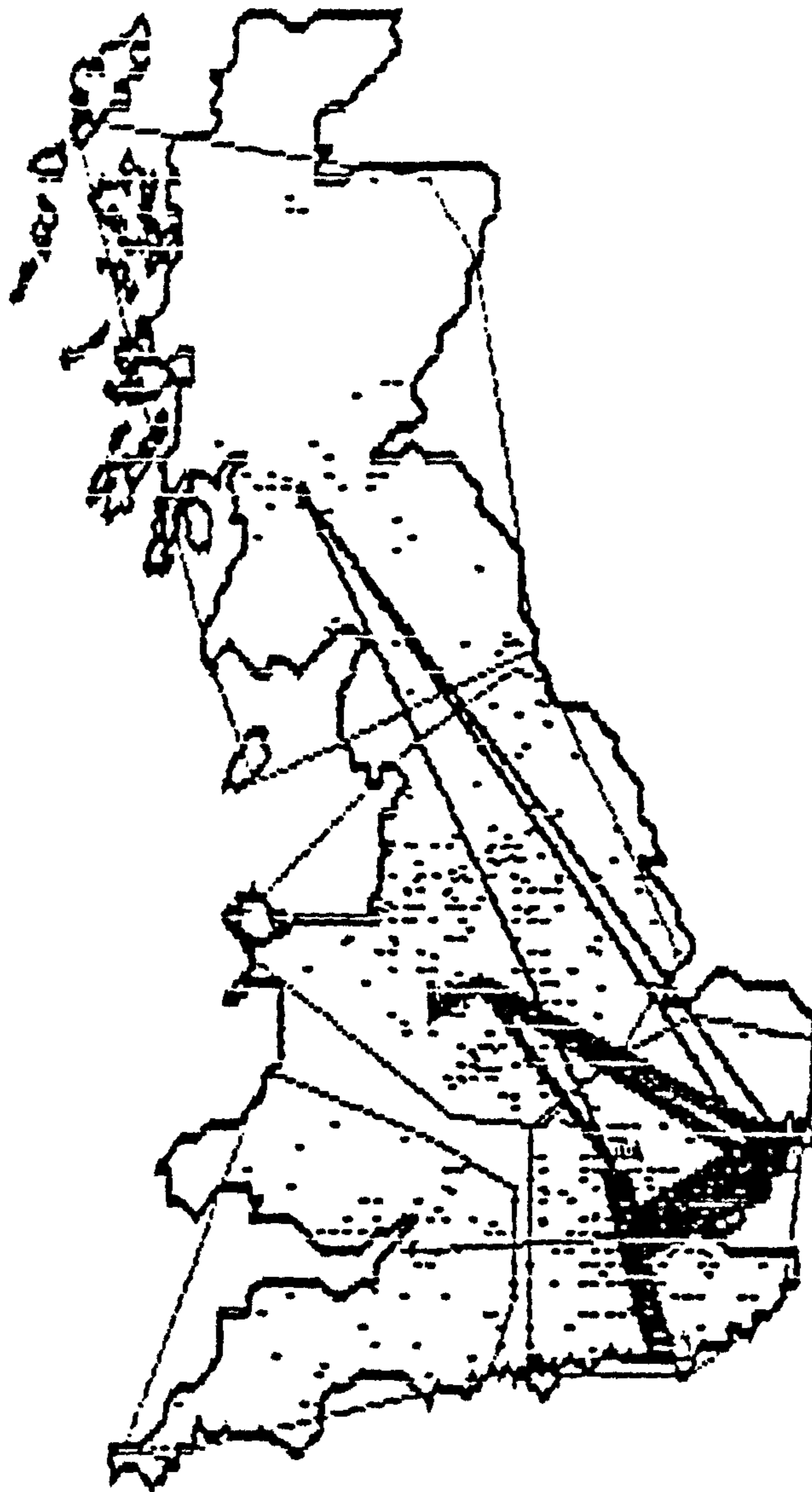

OPTIMISE DEPOT LOCATIONS
 MODIFY DATA
 MANUAL ALLOCATION
 DISPLAY COST/ALLOCATION DATA
 RESTART ALLOCATION
 ZOOM IN
 PRINT SCREEN
 PRINT INPUT DATA
 QUIT

LOCAL/DEL = 35465
 LOCAL/TRUNK = 1356
 TRUNKING = 13888
 DIS/CENTRE = 25886
 TOTAL COST= 74915

FACTORY
 DIST/DEPOT
 TRANS DEPOT
 CUSTOMER

Figure 9.26b 3 Depots options
 (best possible location)

Bristol transshipment point

location search function was used for all the depots and transshipment points in the system and the resulting solution together with its costs are given in figure 9.27b. In the three depots solution, the cheapest solution is for three depots and a transshipment point as depicted in figure 9.27b.

9.2.6 Other alternative

LSM's ability to design a distribution network, where some depots are fixed and others are located in a best possible location was used because the company wished to locate a depot at plant site. The designed distribution network which consisted of a depot at plant site, a second depot at an agreed position and two transshipment points located at the best location places is depicted in figure 9.28b. Clearly this is not the cheapest solution for the company to adopt.

9.2.7 Conclusion

The following recommendation was presented to the company based on the LSM provided solutions:

The central depot option is not a very attractive option for the company. Of the other options, the most favourable is the two depots and two transshipment points option. There may be some administrative advantages in locating the northern depot at the plant site, but there is no clear cost advantage over the best search located two depots and two transshipment points option. There does appear to be real cost advantage in developing a single distribution operation rather than each division operating separately.

The cost breakdown for all options for 1992 is depicted in figure 9.29b. The total cost against the number of depots in a distribution network is plotted in figure 9.30b.

The cost for each constituent of the distribution system such as local delivery, trunking, distribution depots are plotted in figure 9.31b.

TE =10 6 1989
ME =17 25 35

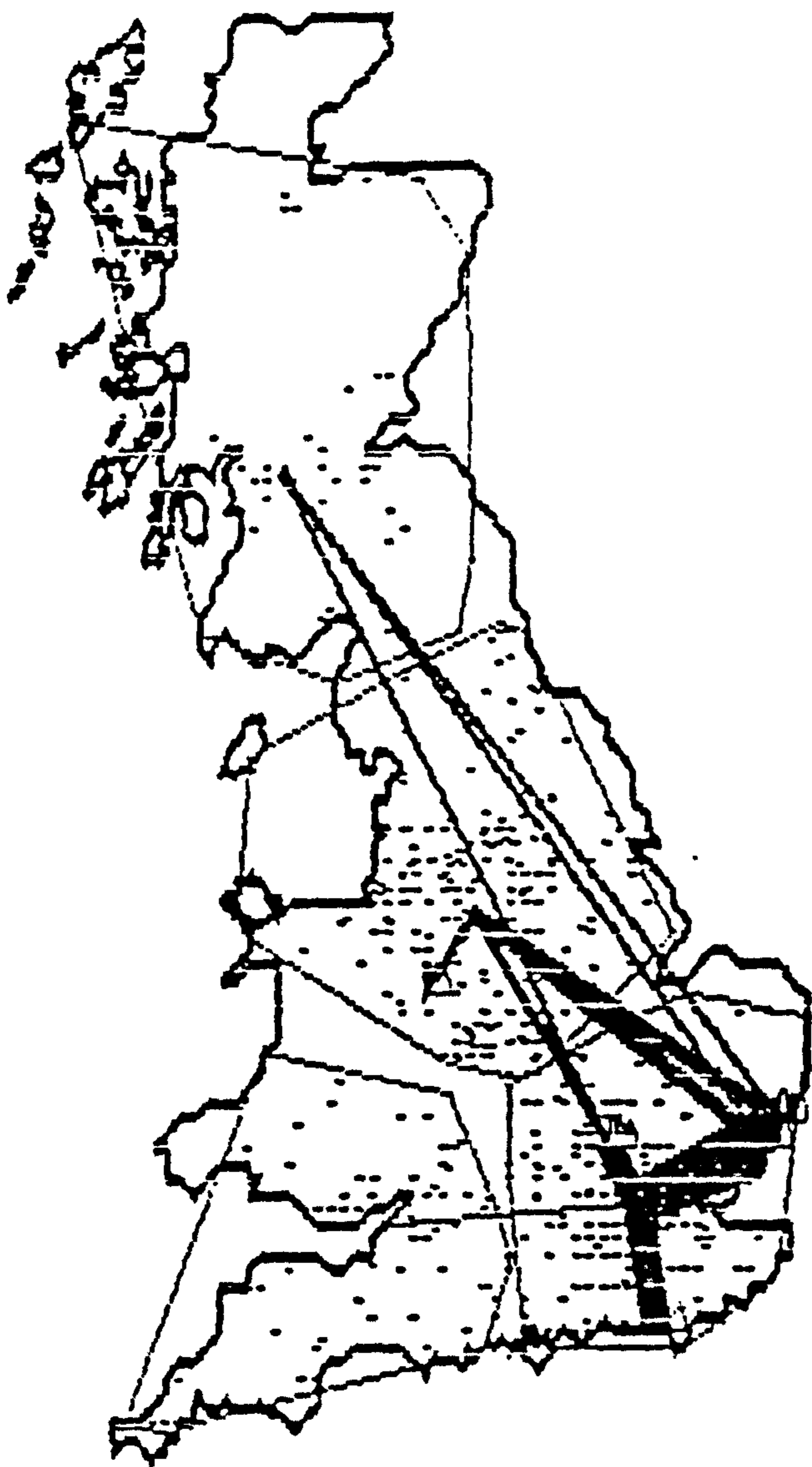

- OPTIMISE DEPOT LOCATIONS
- MODIFY DATA
- MANUAL ALLOCATION
- DISPLAY COST/ALLOCATION DATA
- RESTART ALLOCATION
- ZOOM IN
- PRINT SCREEN
- PRINT INPUT DATA
- QUIT

LOCAL/DEL = 34712
 LOCAL/TRUNK = 1486
 TRUNKING = 13889
 DIS/CENTRE = 25882
 TOTAL COST= 74129

FACTORY
 DIST/DEPOT
 TRANS DEPOT
 CUSTOMER

Figure 9.27b 3 Depots
 Bristol transshipment point
 (best possible location)

DATE = 13 6 1988
 TIME = 10 42 27

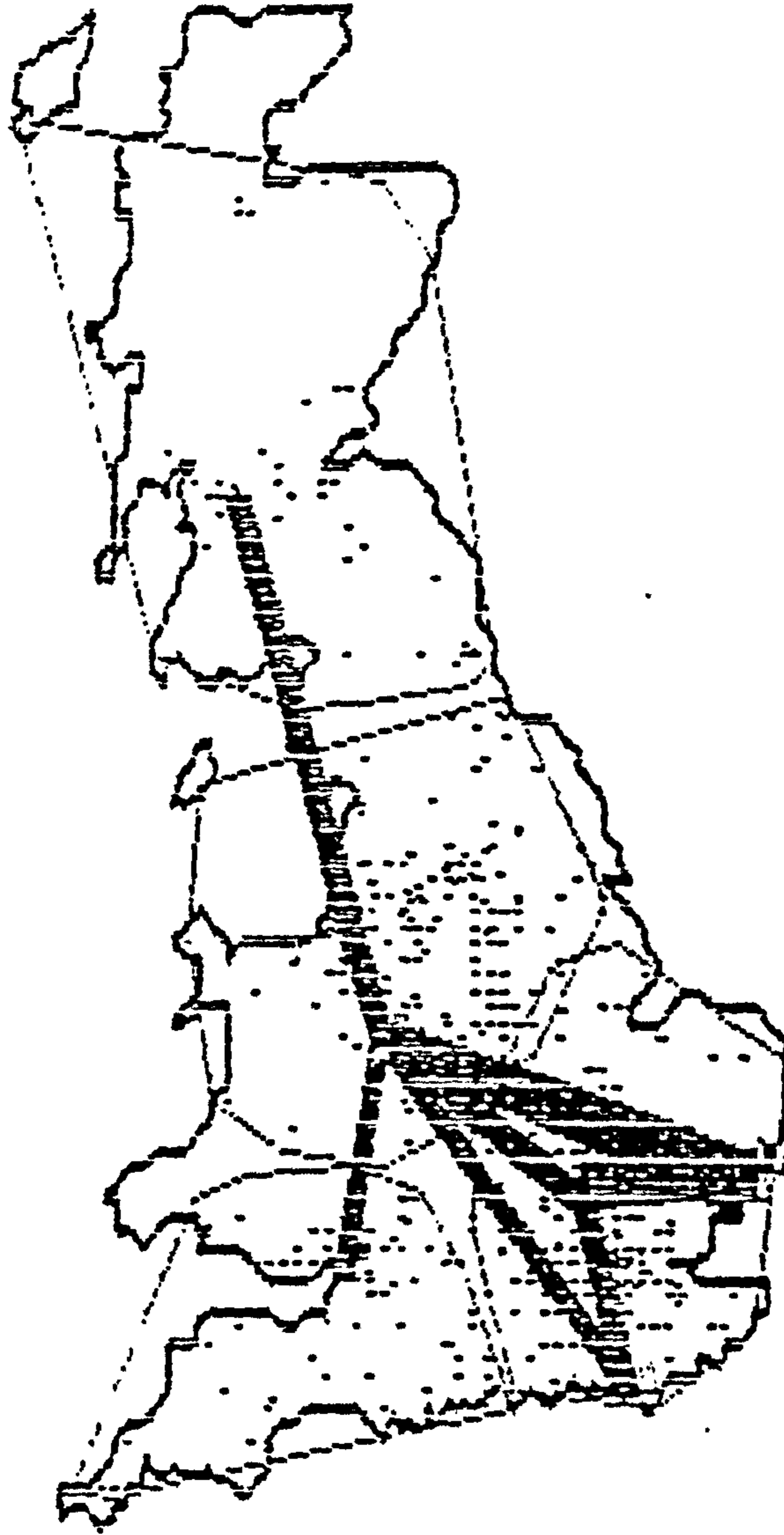

OPTIMISE DEPOT LOCATIONS
 MODIFY DATA
 MANUAL ALLOCATION
 DISPLAY COST/ALLOCATION DATA
 RESTART ALLOCATION
 ZOOM IN
 PRINT SCREEN
 PRINT INPUT DATA
 QUIT

LOCAL/DEL = 42365
 LOCAL/TRUNK = 3749
 TRUNKING = 12972
 DIS/CENTRE = 23193
 TOTAL COST = 82727

FACTORY
 DIST/DEPOT
 TRANS DEPOT
 CUSTOMER

Figure 9.28b 2 depots
 Scottish & Bristol
 transshipment points

Cost Breakdown all options 1992

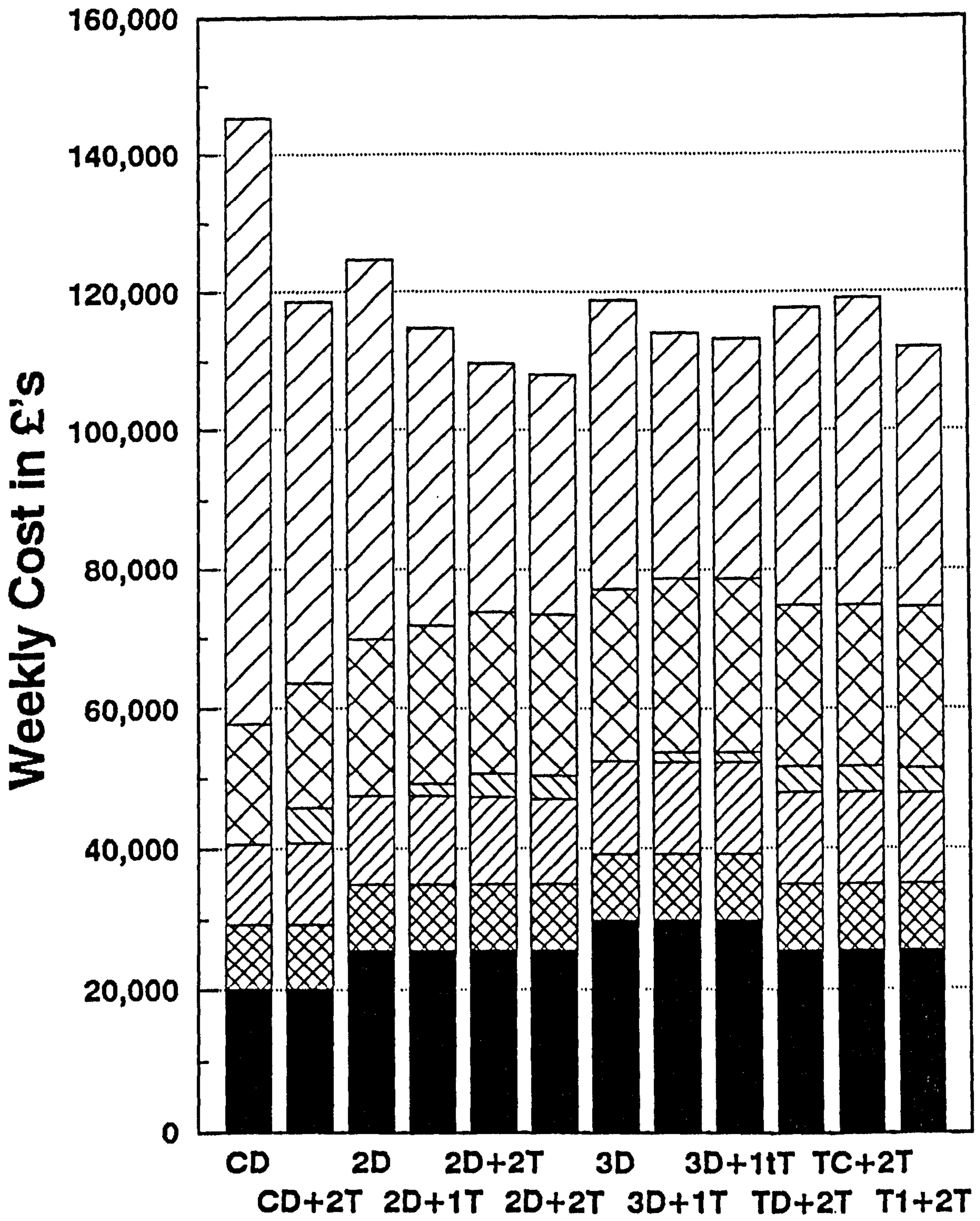

Fig9.29b OPTIONS

SH
 DD
 TK
 TF
 DEP
 LD

Total Weekly Costs for 1992

Total Weekly Costs

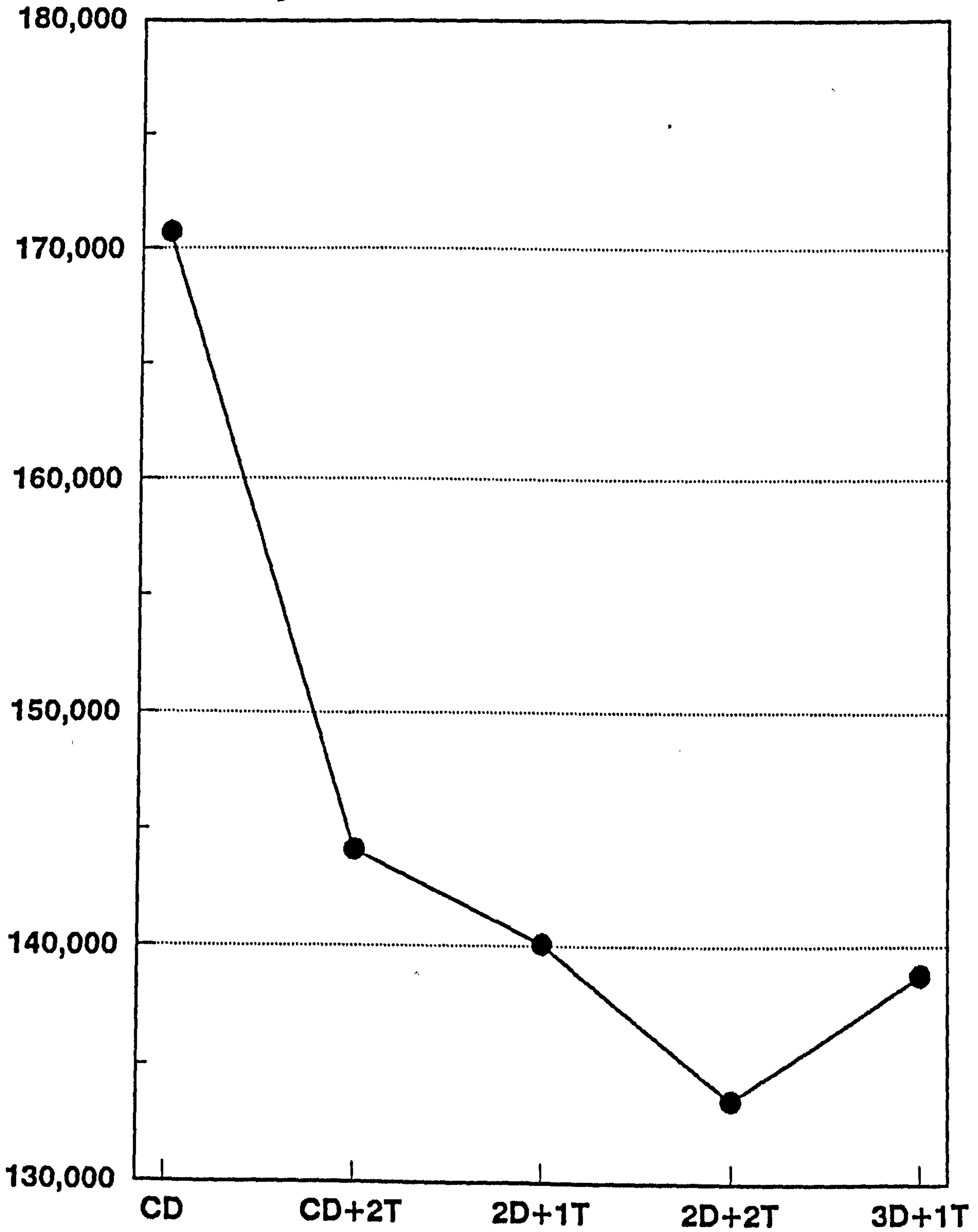

Fig9.30b Selected Options

Cost Breakdown all options 1992

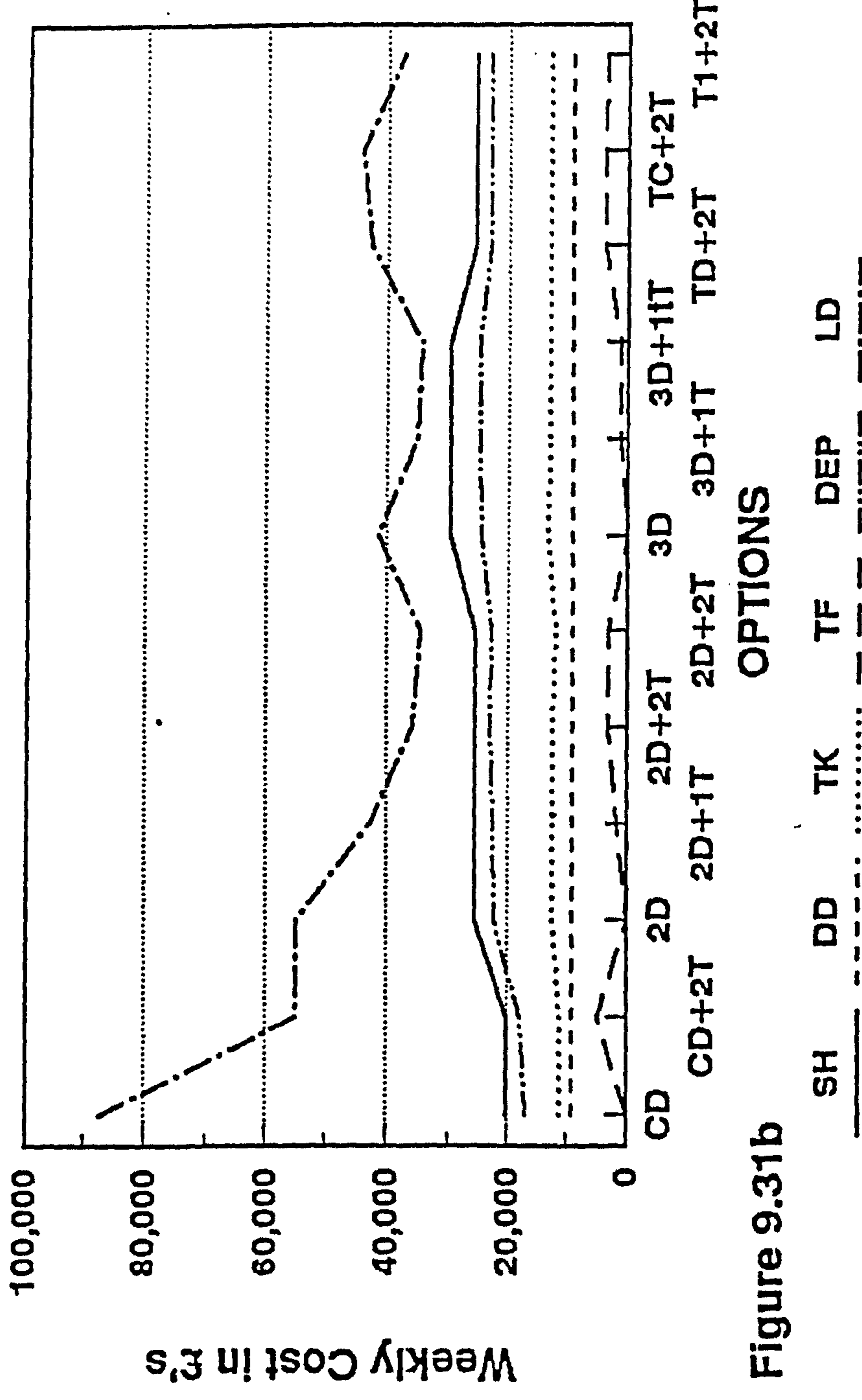

Figure 9.31b

The total cost of the system is consistent with the theoretical curve for different distribution systems recorded from literature in chapter two. The local delivery cost is very high in the single central depot option which is expected, but is still dominant in two depots and two transshipment points solutions. As the number of depots increases the local delivery costs decrease as shown in figure 9.31b. The depot costs increase as the number of depots increase in the system as shown in figure 9.31b.

The major advantages of using the LSM model and approach to design the distribution network structures were:

The validation stage was much easier because the allocation of depots to source points, the boundary of each depot and the cost for each distribution element were all visible on the screen.

The visual interactive search technique helped in this study as it did in case study A. In particular in this study it was essential for the option where the factory site depot was fixed and the other was allowed to move. This facility increases the confidence of the user of the model as it is possible to observe the fixed and moveable depots on the screen.

This case study also showed that LSM is able to model distribution structures using various different units such as kilometres, thus it is suitably flexible.

The deleting of a depot is easy and can be based on an individual's derived rules. If a depot is to be deleted on the basis of minimum throughput, LSM is able to display all depots' throughput on the screen. The user is able to chose the least throughput depot and delete it. If a particular depot/transshipment point has the least throughput but it is vital to keep the depot/transshipment point in an area such as Scotland to serve the region, different criteria for deleting a depot/transshipment point can be used. LSM is an improvement in those models on which the optimum number of depots

are always found by deleting the least throughput depot.

Adding a depot in a particular place affects the whole structure of a distribution network and was crucial for this study. LSM showed visually the customer location and the associated demand could be displayed for all customers in a rectangular box on the screen; this is unique to visual interactive modelling.

To be able to alter source points inside the model is clearly an advantage.

Modification was much easier and results were attainable in a matter of seconds.

Case Study C

9.3.1 Background

This case study demonstrates that LSM can be employed to model in any part of the world (provided data and information are available). This study is based on cement distribution in Pakistan. The demand is based on population density and purchasing power. Information such as location of factories and demand points are taken from the Pakistani Atlas. All the costs are calculated in US dollars.

9.3.2 Objective

To model the distribution system for cement in Pakistan.

9.3.3 Source Points (Factory)

Most of the cement plants are situated in the north of the country near to the raw material. Hence the factories are located at;

Attock

Bada Gowah

Chakwal

Dandot

Daud Khel
 Karachi
 Sukkur
 Texila
 Usman kuttor

9.3.4 Demand Points

Most of the demand is in the major cities such as Karachi, Lahore, Rawal Pindi and Islamabad. One reason for this is the migration of people to main cities for basic services which are not available at the local level. Therefore a great deal of construction is going on in the cities to cope with the influx. The source points and market areas are depicted in figure 9.1c.

9.3.5 Distribution Strategy

The model assumes that distribution depots can be leased any-where in the system. This may not be true as the distribution industry is not fully developed in Pakistan and it may be possible that at some of the depot location places, depots may not be available. All depots are assumed to be located on greenfield sites, so there are no capacity constraints on them. No transshipment is used because it is assumed that depots always keep some stock to meet the required demand in the area.

The figure 9.2c shows the resulting distribution network structure with one central depot. The depot was located at the centre of the country and by using LSM search procedure, the least cost location for depot was found.

The two-depots distribution network is depicted in figure 9.3c. The second depot was added to the system and the overall system optimised by using the LSM search procedure.

A new distribution depot was repeatedly added to the distribution system network until the total system cost began to increase again. Each time a

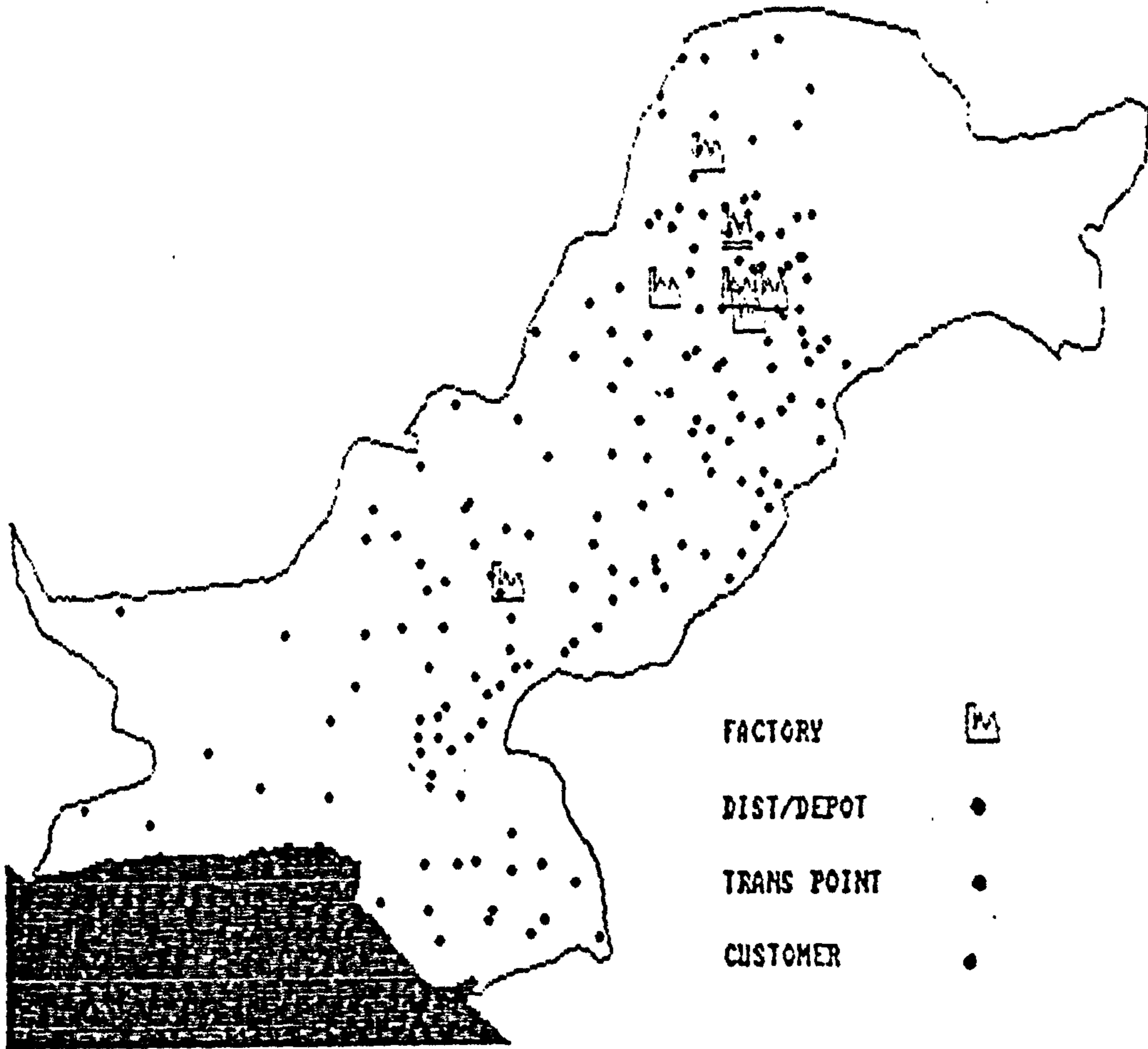

Figure 9.1c
Source points and market area

DATE = 15 8 1990
 TIME = 10 48 6

OPTIMISE DEPOT LOCATIONS
 MODIFY DATA
 MANUAL ALLOCATION
 DISPLAY /PRINT DATA
 RESTART ALLOCATION
 ZOOM IN
 PRINT SCREEN
 QUIT

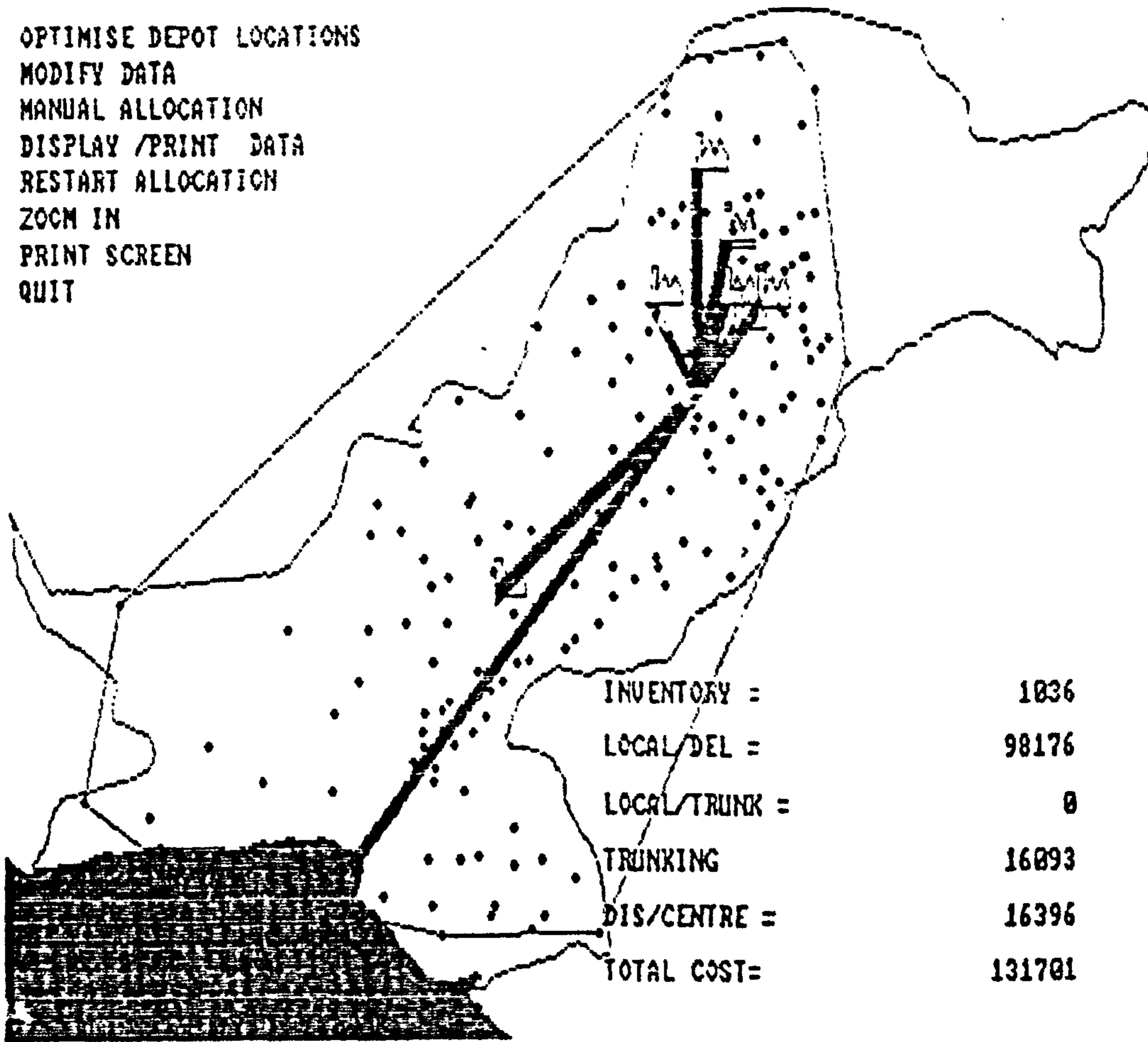

Figure 9.2c
 One depot option

DATE = 15 6 1990
TIME = 11 11 7

OPTIMISE DEPOT LOCATIONS
MODIFY DATA
MANUAL ALLOCATION
DISPLAY /PRINT DATA
RESTART ALLOCATION
ZOOM IN
PRINT SCREEN
QUIT

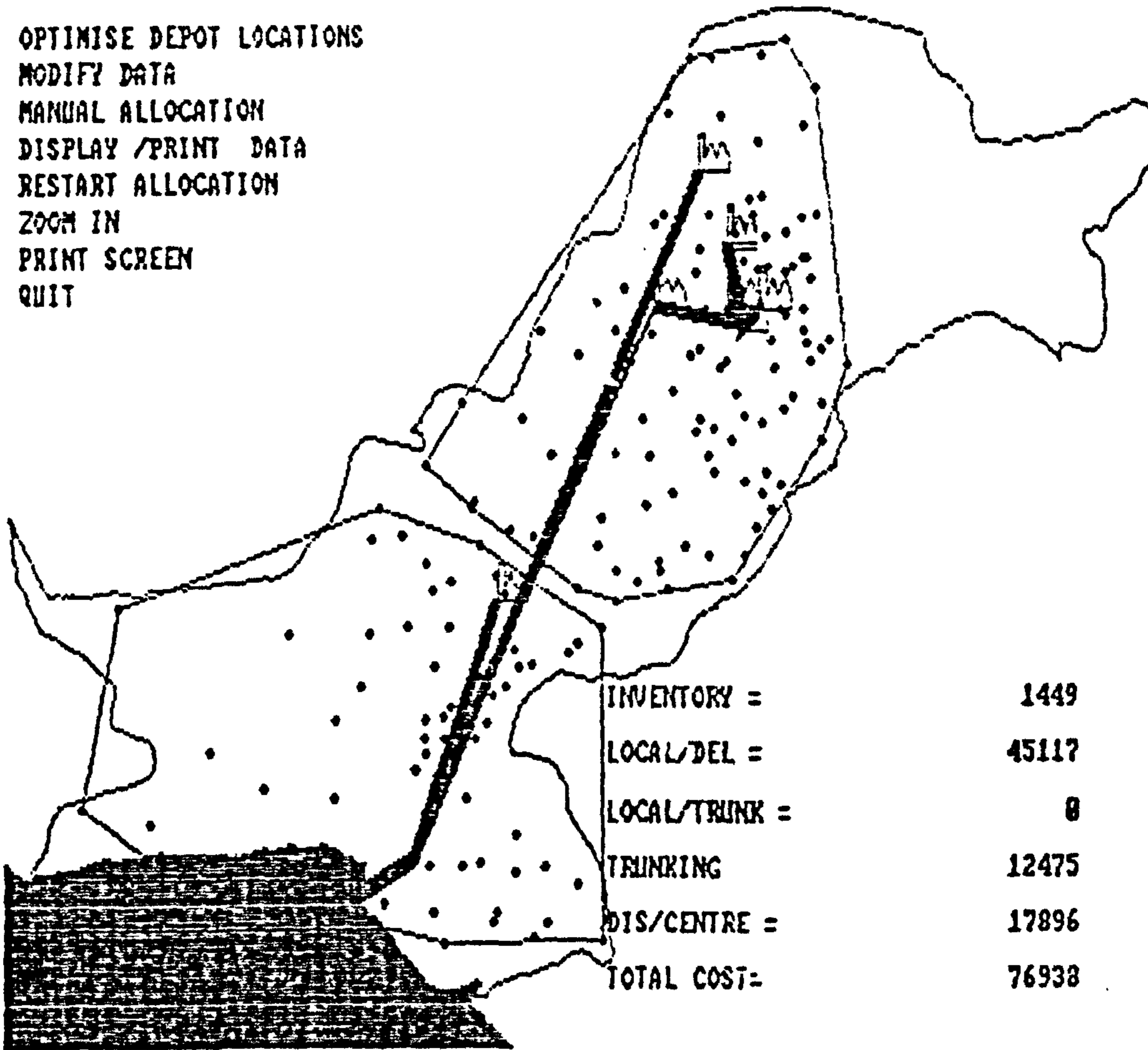

Figure 9.3c
Two depots option

depot was added the system was optimised by using the best search location procedure. Figure 9.4c shows the distribution network developed by three distribution depots. Figure 9.5c shows four distribution depots, figure 9.6c shows five distribution depots, figure 9.7c shows six distribution depots, figure 9.8c shows seven distribution depots, figure 9.9c shows eight distribution depots and figure 9.10c shows a nine distribution depot network.

9.3.6 Conclusion

The number of depots in the distribution system and the total local delivery cost of the system is plotted in figure 9.11c. It is a recognised theory that as the number of depots in a system increases, the local delivery cost decreases (provided the depots are located in reasonable positions); figure 9.11c is in line with this theory. Figure 9.12c shows the total number of depots in the system versus trunking cost. Generally if the number of depots increases the trunking cost will also increase. However, that depends on the location of factories and depots. This is clearly reflected in figure 9.12c. When the number of depots is increased from one to two, the trunking cost is actually reduced considerably. Figure 9.13c shows the number of depots versus the total depot cost. The cost is increasing linearly because as the number of depots increases the total cost also increases. The inventory cost against the number of depots in the system is plotted in figure 9.14c. The cost increases as the number of depots increases in the system, but the increase is not linear. The total system cost is plotted against the number of depots in the system. The overall cost decreases while the number of depots is lower than or equal to seven, but it starts increasing after this point. All the costs against the number of depots are plotted in figure 9.15c.

If all the assumptions are correct then it could be recommended to the company to use a seven depot distribution network structure for its distribution system.

This case study shows that LSM can be used to model distribution systems

DATE =15 3 1990
TIME =21 27 40

OPTIMISE DEPOT LOCATIONS
MODIFY DATA
MANUAL ALLOCATION
DISPLAY /PRINT DATA
RESTART ALLOCATION
ZOOM IN
PRINT SCREEN
QUIT

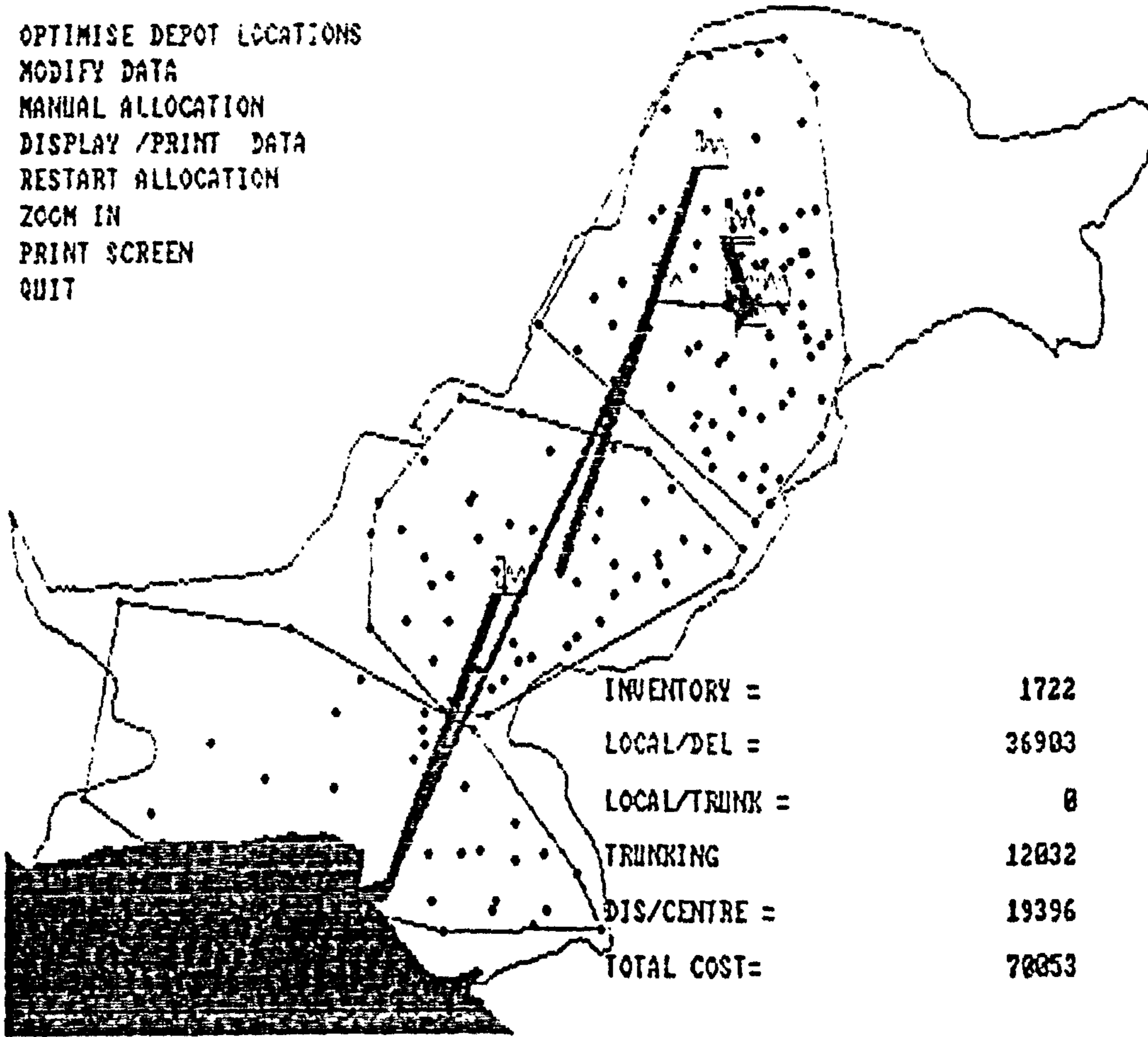

Figure 9.4c
Three depots option

DATE = 15 8 1990
 TIME = 11 37 30

OPTIMISE DEPOT LOCATIONS
 MODIFY DATA
 MANUAL ALLOCATION
 DISPLAY /PRINT DATA
 RESTART ALLOCATION
 ZOOM IN
 PRINT SCREEN
 QUIT

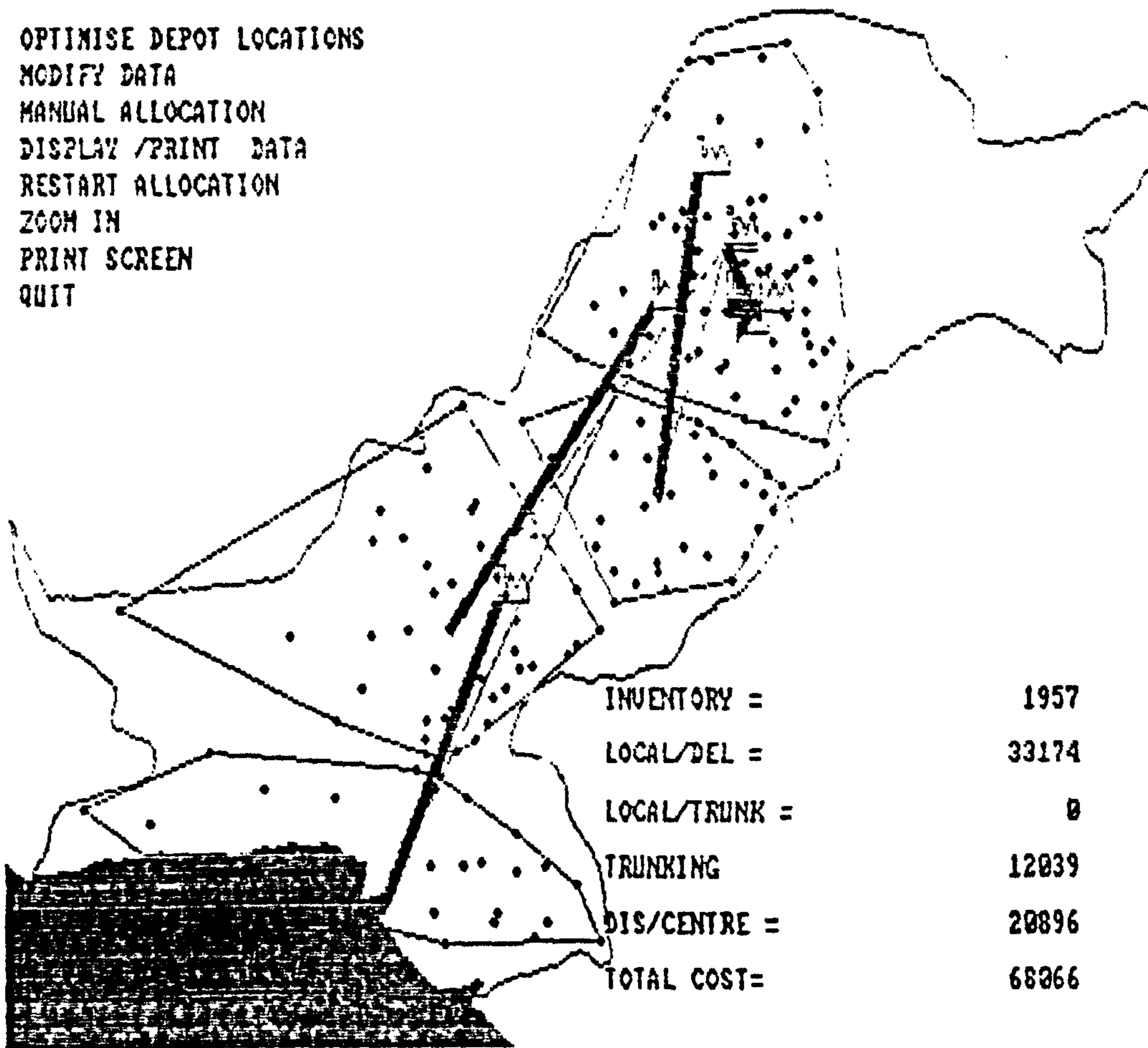

Figure 9.5c

Four depots option

DATE = 11 11 1990
TIME = 11 11 11

OPTIMISE DEPOT LOCATIONS
MODIFY DATA
MANUAL ALLOCATION
DISPLAY /PRINT DATA
RESTART ALLOCATION
ZOOM IN
PRINT SCREEN
QUIT

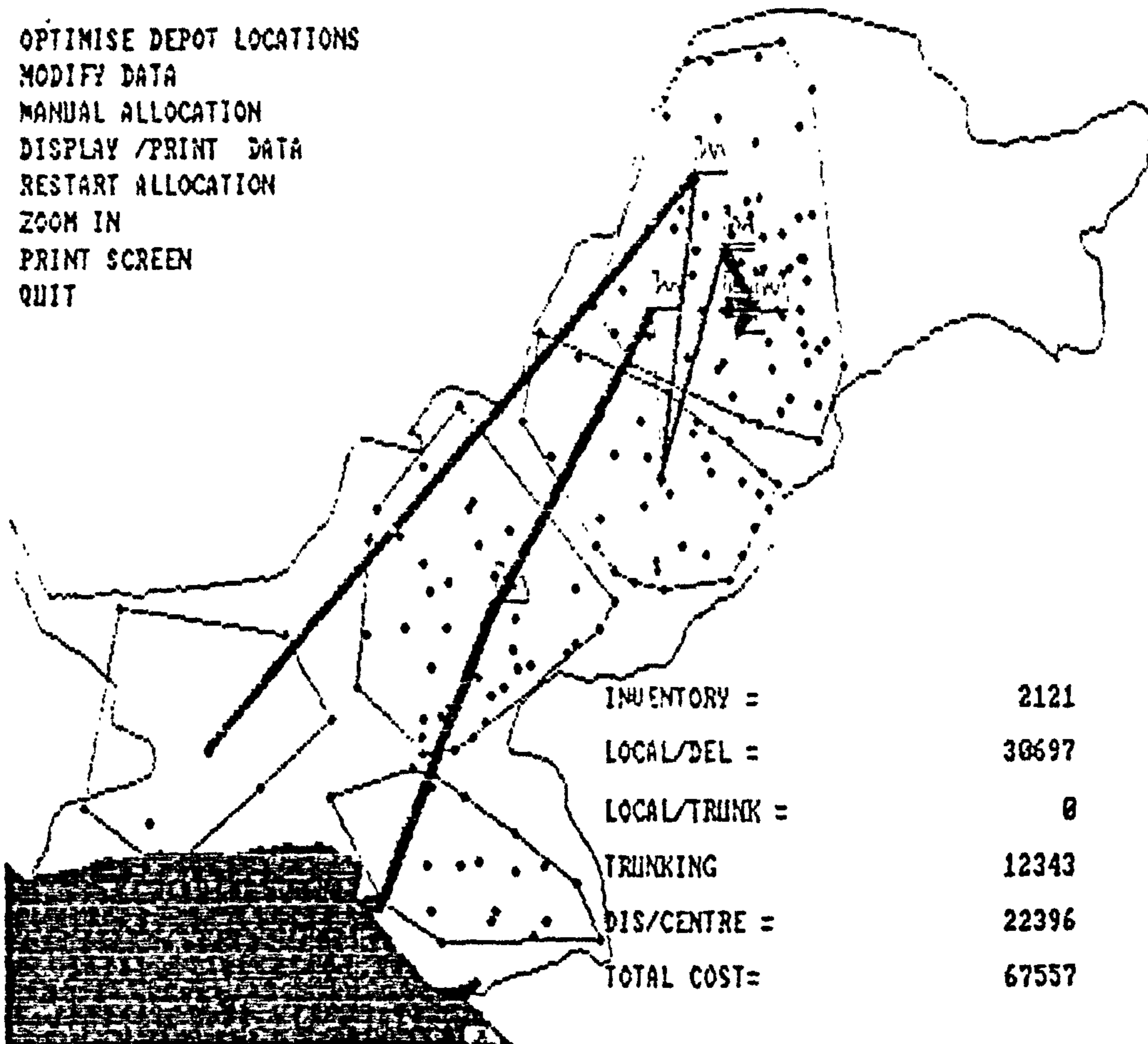

Figure 9.6c
Five depots option

DATE = 15 2 1990
TIME = 11 1 27

- OPTIMISE DEPOT LOCATIONS
- MODIFY DATA
- MANUAL ALLOCATION
- DISPLAY / PRINT DATA
- RESTART ALLOCATION
- ZOOM IN
- PRINT SCREEN
- QUIT

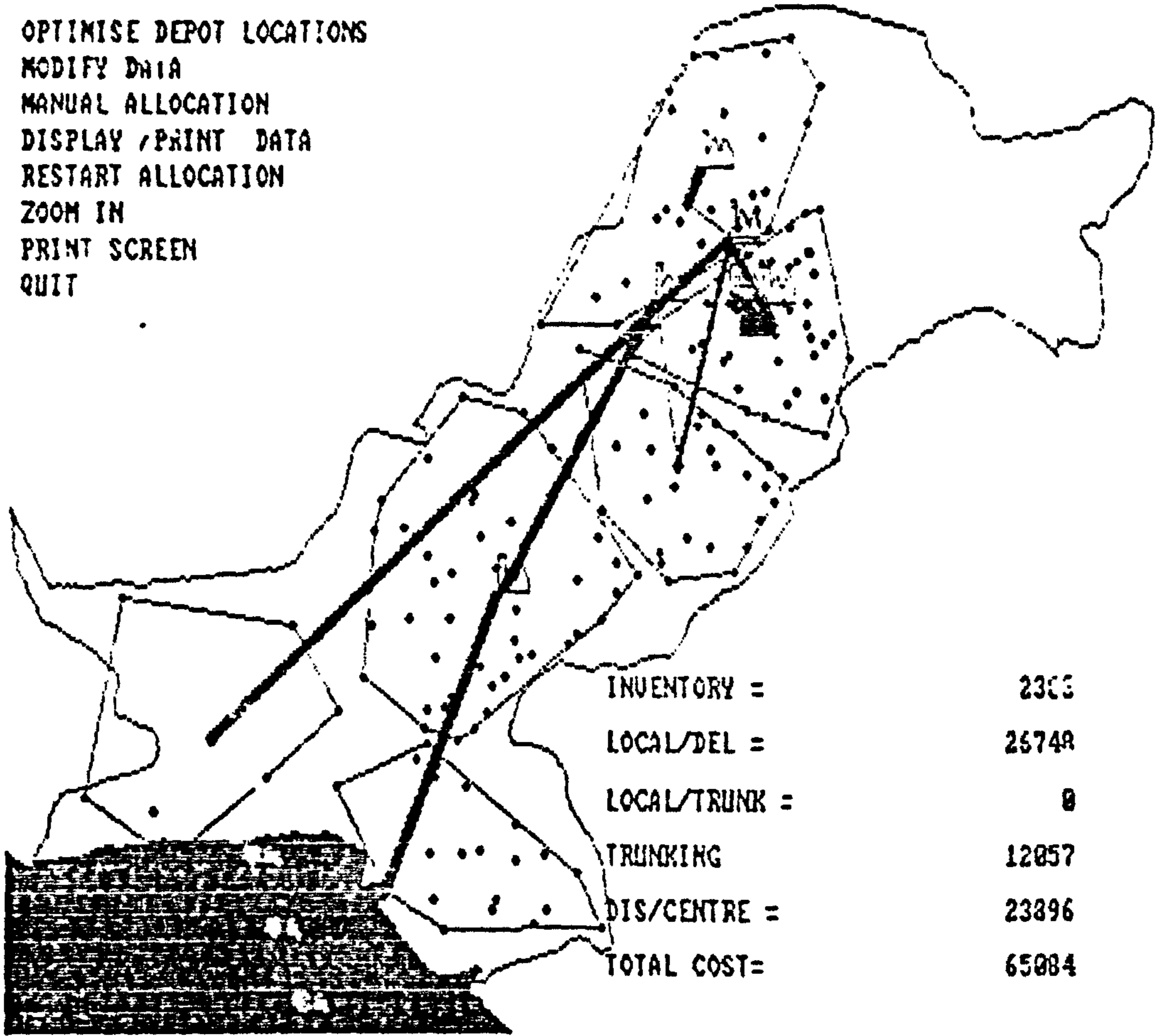

Figure 9.7c
Six depots option

DATE = 11 1 1980
 TIME = 11 11 11

OPTIMISE DEPOT LOCATIONS
 MODIFY DATA
 MANUAL ALLOCATION
 DISPLAY /PRINT DATA
 RESTART ALLOCATION
 ZOOM IN
 PRINT SCREEN
 QUIT

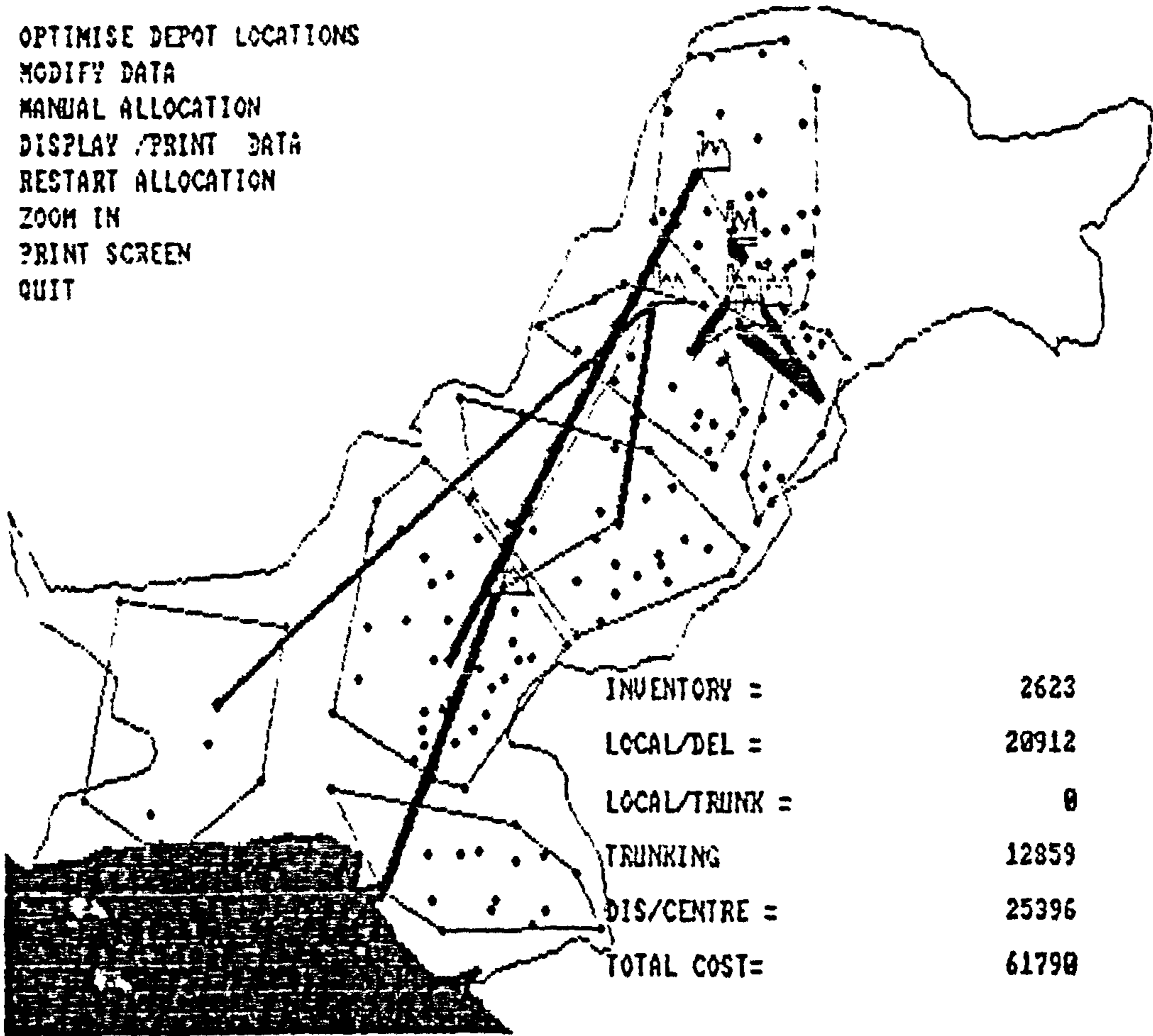

Figure 9.8c
 Seven depots option

DATE = 15 5 1990
 TIME = 22 29 58

OPTIMISE DEPOT LOCATIONS
 MODIFY DATA
 MANUAL ALLOCATION
 DISPLAY /PRINT DATA
 RESTART ALLOCATION
 ZOOM IN
 PRINT SCREEN
 QUIT

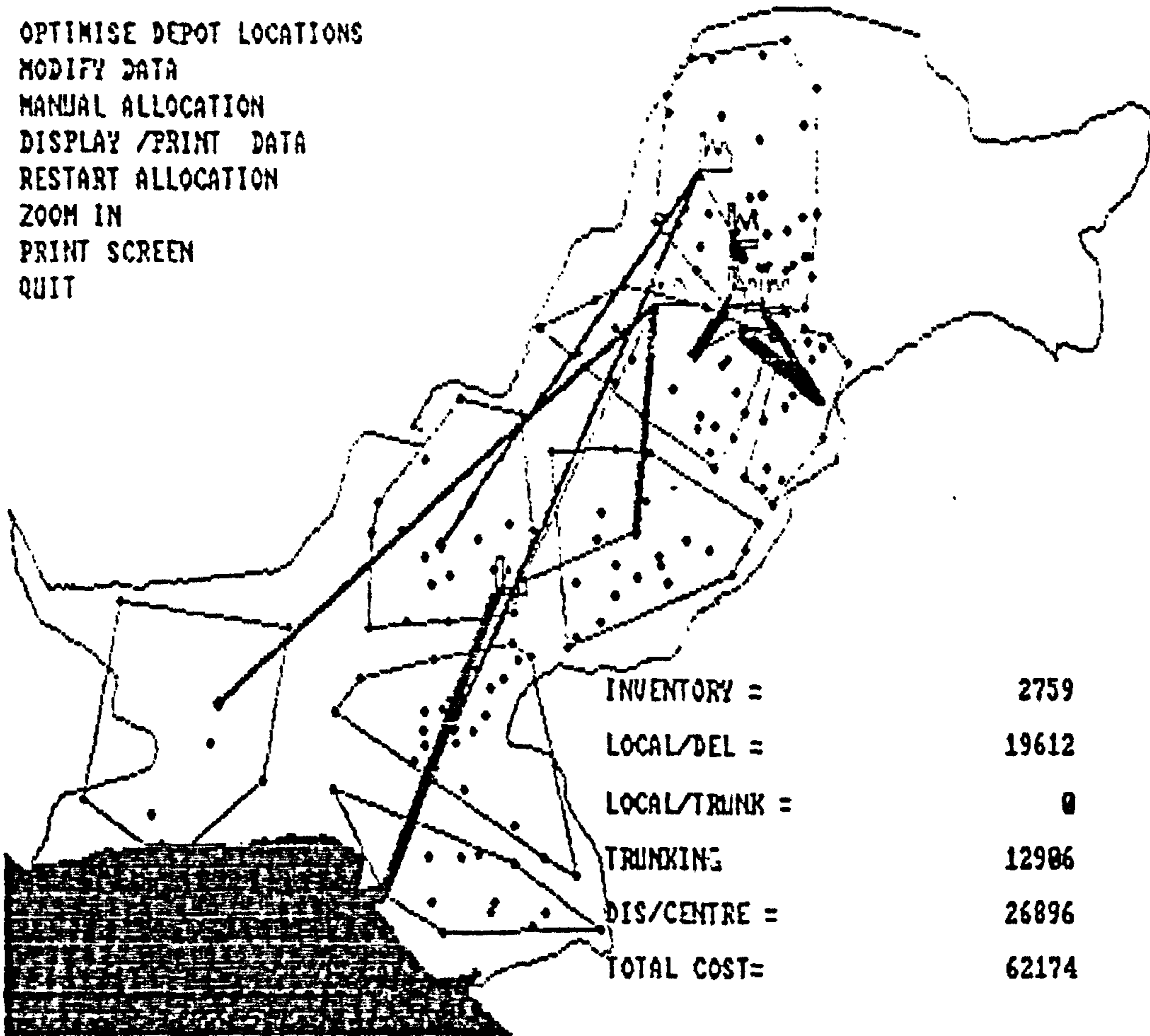

Figure 9.9c
 Eight depot option

DATE = 18 8 1990
 TIME = 22 49 11

OPTIMISE DEPOT LOCATIONS
 MODIFY DATA
 MANUAL ALLOCATION
 DISPLAY /PRINT DATA
 RESTART ALLOCATION
 ZOOM IN
 PRINT SCREEN
 QUIT

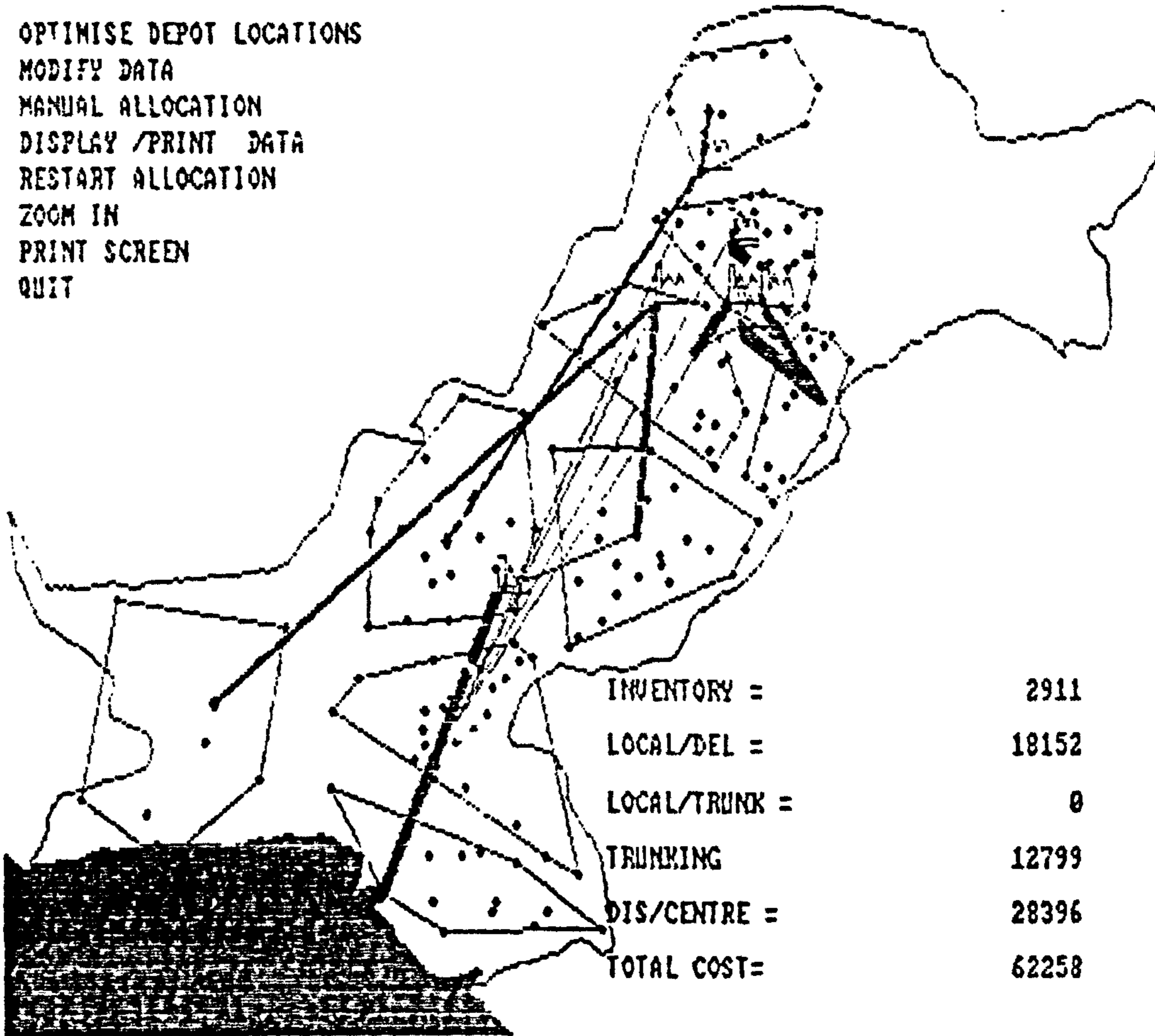

Figure 9.10c
 Nine depot option

Number Of Depots Vs Local Delivery Cost

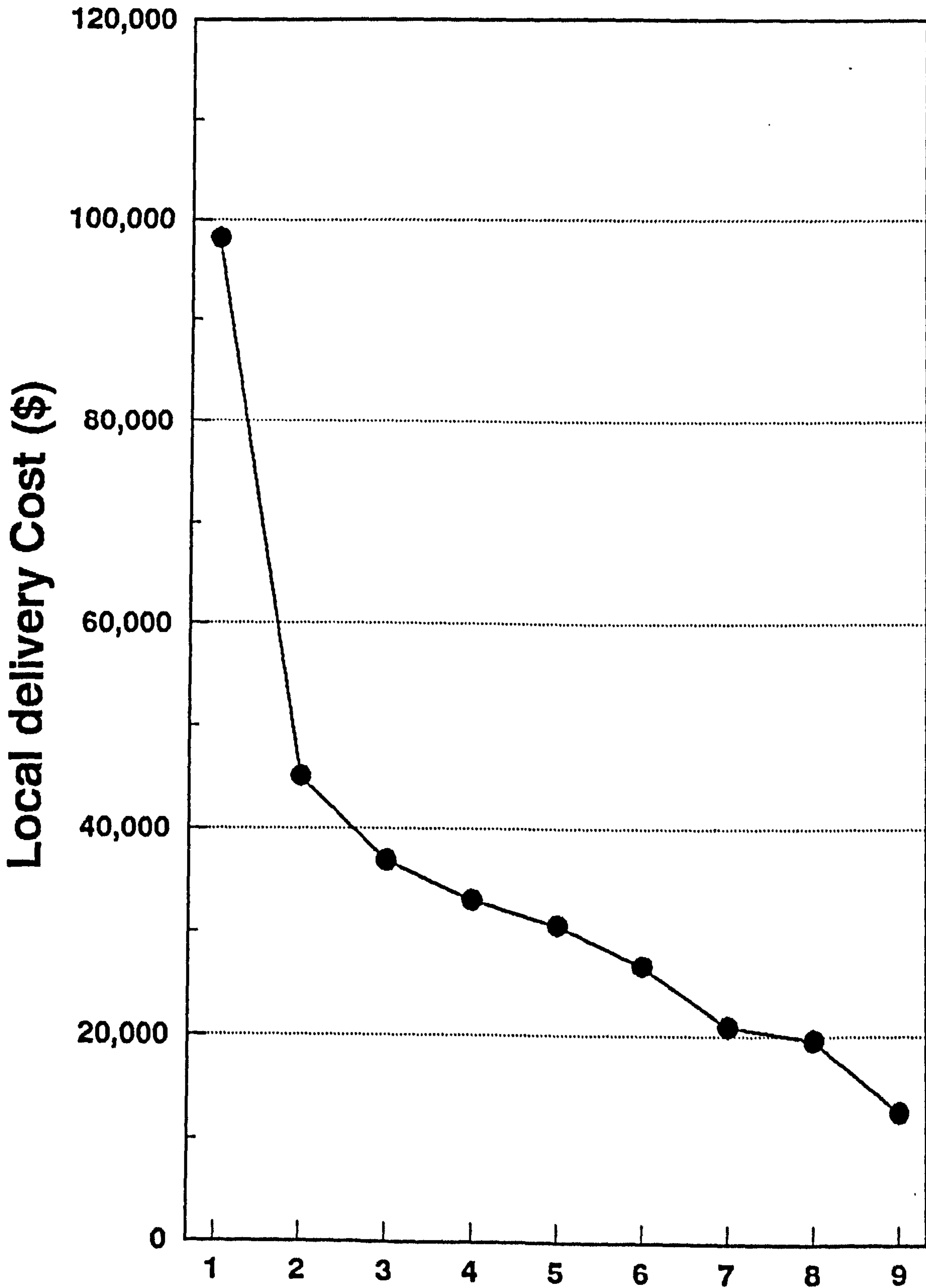

Fig9.11c Number of Depots

Number of Depots Vs Trunking Cost

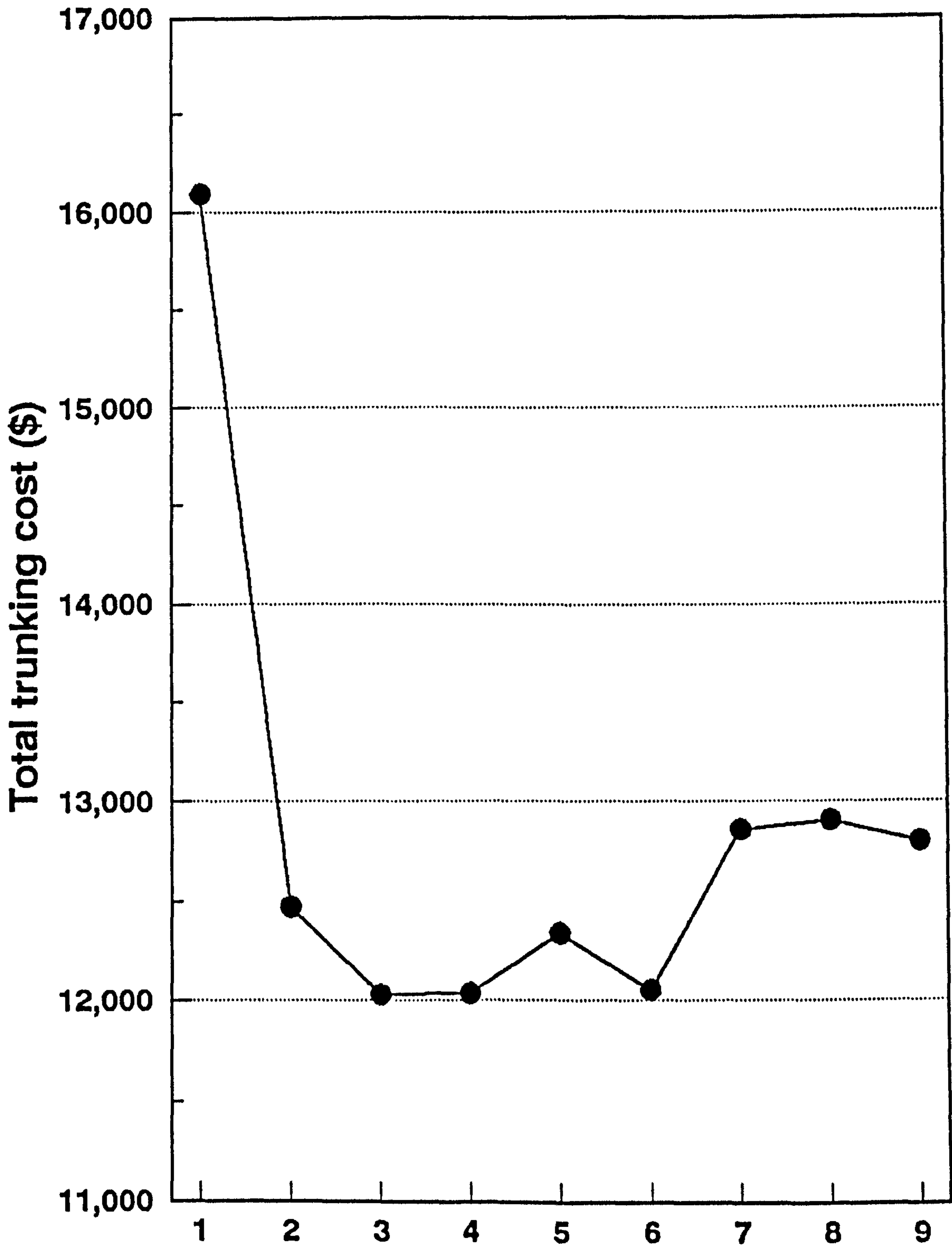

Fig9.12c Number of depots

Number of depots Vs depot cost

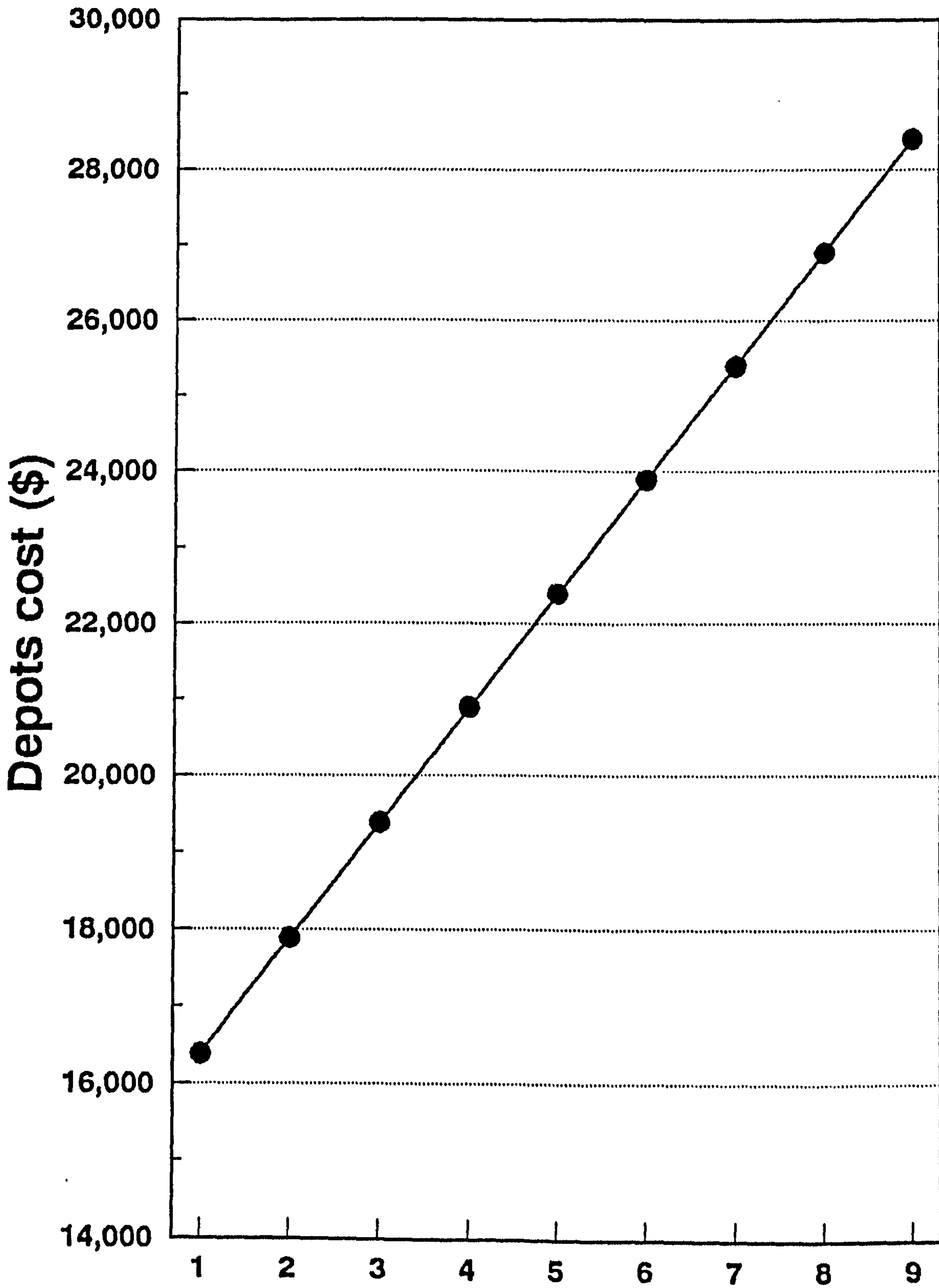

Fig9.13c Number of depots

Number of Depots Vs Inventory Cost

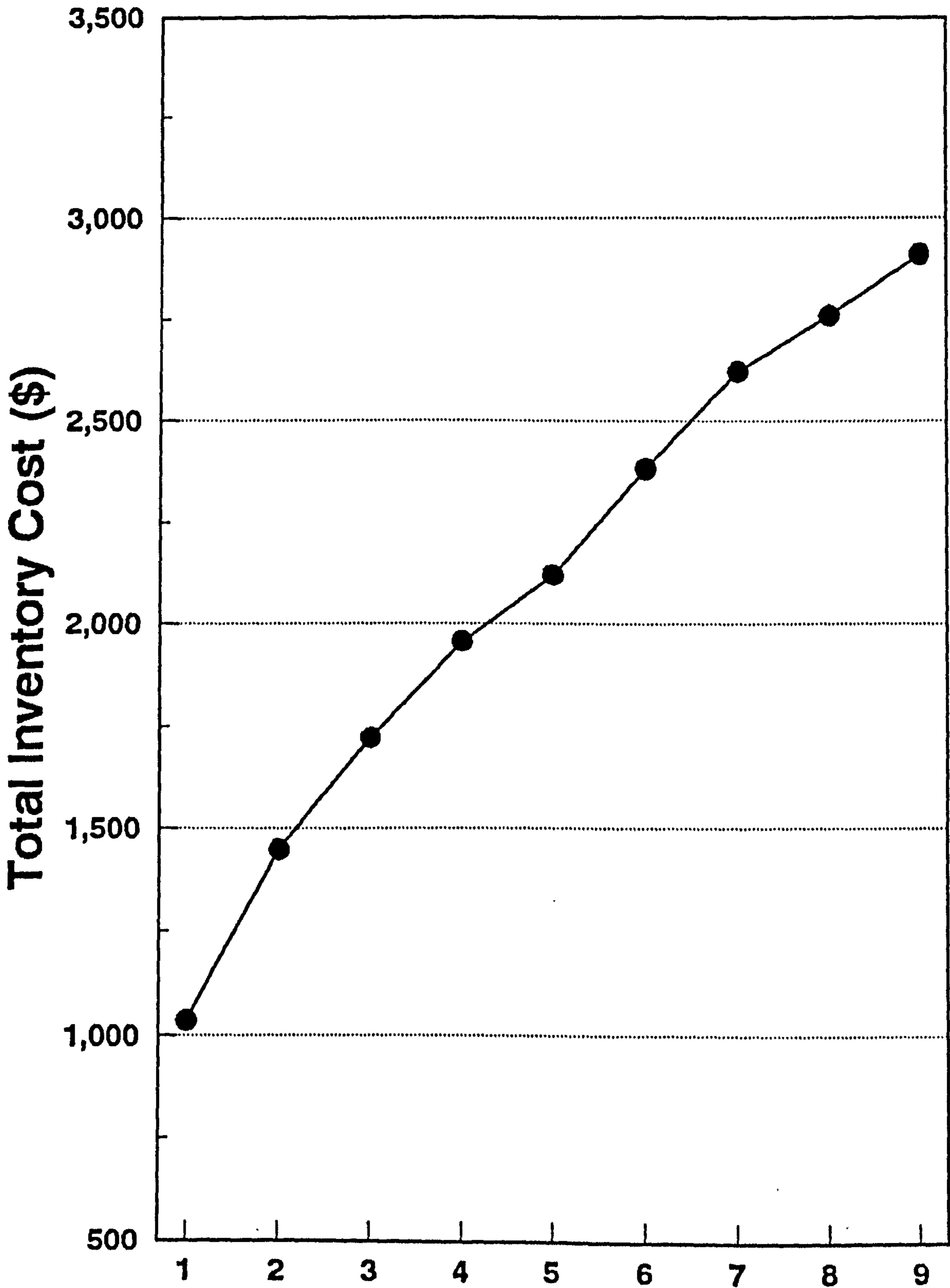

fig9.14c Number of depots

Number of depots Vs total cost

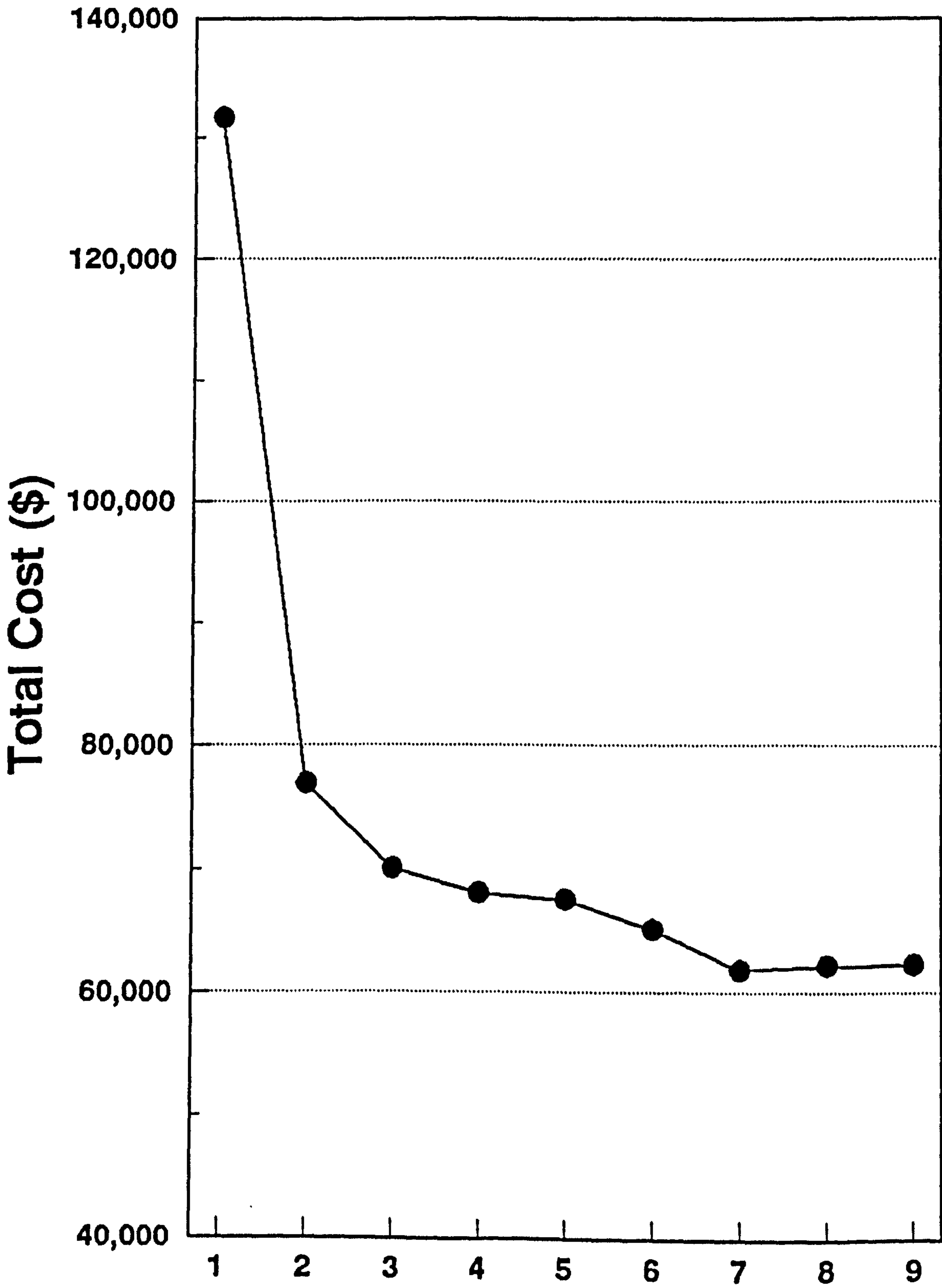

fig9.15c Number of Depots

Number of Depots Vs Cost

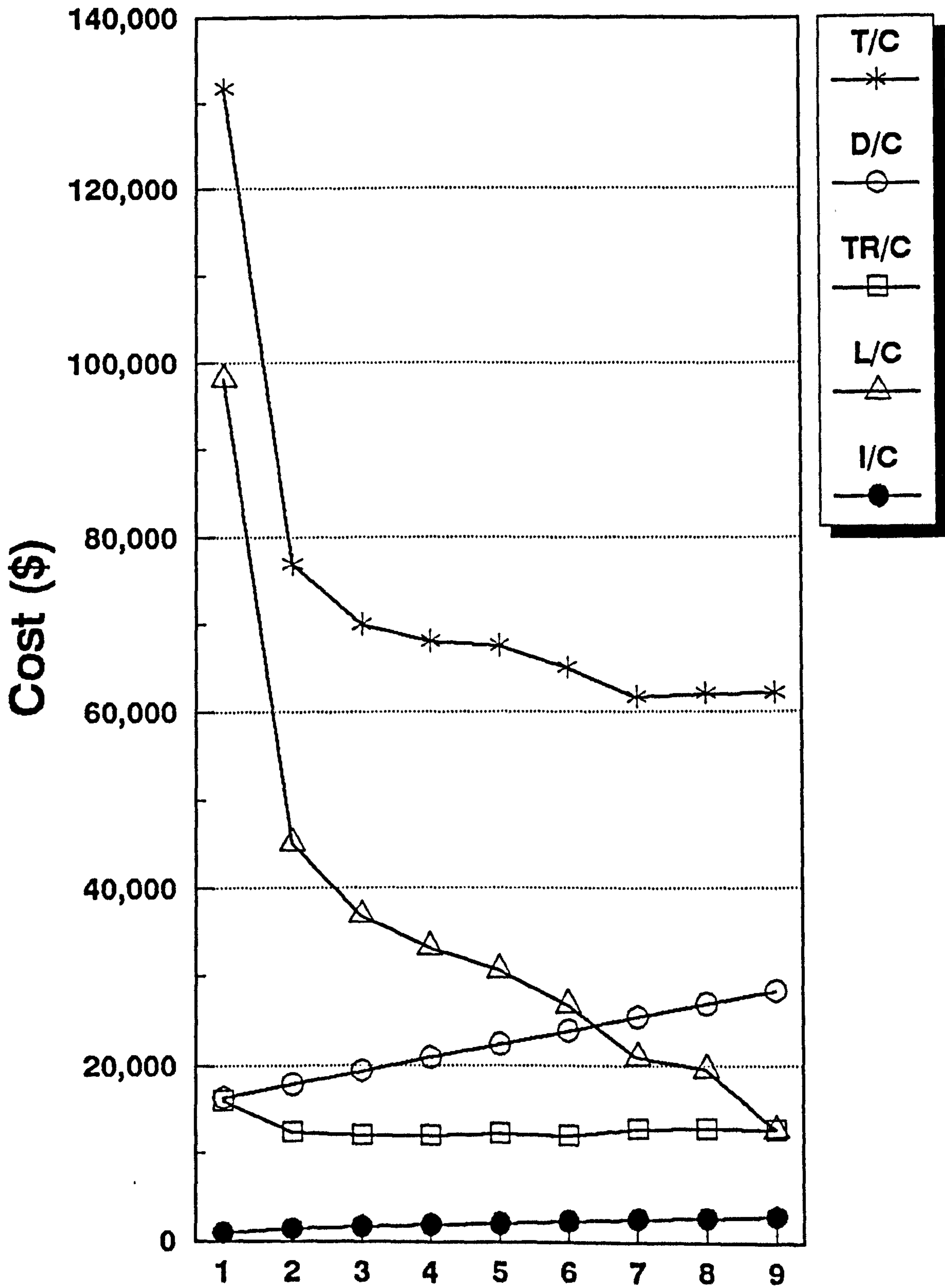

fig9.16c Number of depots

in the developing countries as well as the developed world. It is also very adaptable to different geographic regions.

Another factor which is a product of visually interactive modelling and is particularly useful in the under-developed world is LSM's ability to highlight the distribution problem. By using LSM one is able to display the existing operation and is able to produce an alternative very easily. This will help not only in the solution of the problem but also will help those who do not know how to comprehend the problem.

9.4 Conclusion & Summary

The recommendations to each company are described at the end of each case study. LSM is developed for practical application in the logistics industry and therefore in this section LSM costs and their calculating algorithms and their performance in practice will be discussed. The discussion will also be focused on the modelling approach used by LSM. Since this approach was adopted for practical use, its advantages at the practical stage will be described.

In chapter two logistics system costs were described; LSM includes all the required costs for a logistics system at a strategic level. The costs included are:

- local delivery cost;
- trunking delivery cost;
- local trunking cost;
- inventory cost;
- warehouse handling and fixed cost.

The design of a distribution network structure depends on the relationship between different costs. LSM represents these costs in a balanced order. Some of the software reviewed in chapter five is biased towards particular costs. Some simulation packages include extreme detail - local delivery costs and

parameters such as time windows for each customer delivery, but inventory cost is not considered at all. One model in chapter five was developed specifically to consider inventory cost in great detail. As sub-system specific models they are often very useful but they can rarely be used to model total distribution systems at the strategic level because they cannot reflect the true nature of the problem.

The local delivery and trunking algorithms used in LSM are available in the subject literature. They do not include all of the time concepts inherent in distribution at the operational level. Legislation that drivers can only drive a limited number of hours per day are important in practice but its inclusion in strategic models can produce unnecessary complications. For local delivery, LSM includes the stem time, zone time and unloading times. It does not include waiting time nor time windows at customers. For trunking only the stem time is considered.

In the case study A, the outbound cost from the depot to customer was lower than the inbound cost from source point to depot. Therefore the depots were located close to the source point. In the case of study B, the trunking cost was lower than local delivery cost. The depot and transshipment points were located near the demand centres. This shows that the proposed algorithm worked satisfactory in real world problems and that LSM is a cost driven model.

The warehouse cost is a combination of fixed and variable costs. LSM is able to model different fixed and variable costs for each warehouse. This approach can be used to take into account land prices which are far from uniform and the different handling technology being used at different distribution depots. This algorithm worked very well in practice particularly where transshipment points have very low fixed costs.

The cost of inventory against the number of depots was plotted in figure

9.14C for case study C. The cost increased as the number of depots in the system increased but the increase is not linear. This clearly agreed with values obtained from the literature.

The advantages of using LSM and particularly its approach to modelling logistic systems are summarised as follows:

LSM's visual interactive approach to model logistic systems is not only useful in problem solving but it also has advantages in highlighting the problems. Users and managers were clearly able to observe the disadvantages of their existing systems at the model validation stage. This was possible because LSM presented the problem using visual computer graphics techniques.

It is the objective of most distribution companies to serve their customers in the most inexpensive way at the required service levels. LSM builds a least cost network path from customer to source points as do some of the reviewed models in chapter five. It also goes a stage further and shows the area being served by the depot on the screen. LSM is the only model at present which separates the serving areas of depots and transshipment points by visual interactive means. It draws lines in different colours for each depot and transshipment point.

This technique shows clearly at the validation stage which customers are served by which depot. Since at the validation stage, the model was replicating the existing operation, it also indicates the implications of allocating one customer to a different depot than its existing one. The models advantages were very apparent on optimum allocation. It shows the cheapest warehouse to serve a customer.

LSM draws boundaries around the depot and transshipment point as shown in case studies B and C. Its drawn boundary lines are concise and clear when there is one source point and one product. However in some cases, when there

is more than one product and more than one source point producing the product, then the overall boundaries for distribution centres may overlap each other. This is due to the fact that distribution centres are able to receive the product from more than one source and are able to deliver more than one product.

On the allocation of more than one transshipment point to a depot, the flow of volume by thickness of lines showed which transshipment point has the greater demand. This also applies to source points. When one source point serves more than one depot, the width of the line shows the flow of volume from the source point. This helps at the validation stage and later when modelling the system because it reflects the higher and lower demand areas in the system.

LSM is the only model at present which searches for the best possible location for a depot/transshipment point by visual interactive means. This algorithm in practice always produces a total system cost lower than or equal to that which it started. This is a fundamental component of LSM. The major advantages for modelling the distribution system with a computer graphically interactive model such as LSM is that the user is able to visualise where the actual location of a depot is and to where it can be moved. LSM has clear advantages over other simulation models for the movement of depots. In the above studies, depots were located in the best possible locations chosen by the user but it was interesting to see where the computer placed the depots and to what extent this further reduced overall system costs.

LSM's "what if" facility contributed significantly to the design of different distribution network structures. The main advantages were as follows:

It is a very user-friendly decision support system, it responds very quickly to any change, and reflects the results by means of interactive graphics, which encourages the user to explore all its functions.

It was very easy to modify the data during the network building and observe the cost impact on the total logistic system design.

The number of depots/transshipment points are always important to any distribution network. Their location is crucial to the whole strategy of a distribution system. Most "what if" strategies depend on adding or deleting depots. LSM has a function by which existing depots' utilisation can be checked during the "what if" process. A particular area's demand can be displayed on the screen by using visual windows. This as a whole helps to locate the depot at the best possible position by interactive means. The depots are added by moving the cursor to a location position.

Change in demand is one of the fundamental components for strategic planning. The "what if" facility for demand was very useful, especially the visual interactive one. The user is able to draw a rectangular shape on the screen and the demand in the area can be changed according to forecasting factors. This allows the user to highlight only those areas where demand increases are expected.

The LSM "what if" function for allocation can also be used to compare a customer's being served by different depots and its associated cost.

Zooming can also be used to see more details of the location of customers, depots and the area they are serving.

Chapter Ten

Model's Review

10.0 Introduction

In this chapter, the model will be critically analyzed. There is no single model which is able or will be able to solve all logistics strategy modelling problems. To attempt to achieve this at present is a very ambitious objective. This chapter also suggests directions for future research in logistics system modelling.

10.1 Critical analysis:

In its local delivery algorithm, LSM does not deal with delivery frequency. If a logistics system is being modelled on a weekly basis and a cost is calculated first on the basis of a product being delivered three times a week to a customer and then on the basis of the same amount of product being delivered in two trips each week, the model will give equal local delivery costs. In practice the result will be different.

10.2 Drawbacks:

It is not a decision making model. It does not decide the minimum number of distribution depots or transshipment points that are required for a logistics system. It does not guarantee a true optimum location for a distribution facility and therefore it is not a true optimisation model. It does however have an optimization facility which can provide a local optimum based on the algorithm's heuristic. The model is biased towards greater demand customers when searching for the best location for a depot. In a multi-distribution depot system, the final structure of distribution thus depends on the initial location of depots.

It is not an operation model. Therefore it does not include detailed information on local deliveries such as customer delivery time and day of delivery. It does not use different types of vehicle for local delivery. It also does not deal with different modes of transport for trunking delivery.

It only runs on IBM PC and compatible computers.

The model does not take into account the cost of transporting raw materials from its source to the production plant. It also does not consider the production cost for any product at any production plants or inventory cost for raw material at the production plant.

10.3 Further Research

Further research is clearly needed in the development of a local delivery algorithm for strategic levels. At present such an algorithm is missing from the literature. This should be one which is able to handle delivery frequency at strategic levels. Delivery frequency becomes very important when customer demand is small or when daily deliveries are needed as in the grocery industry.

However there are some routing and scheduling algorithms available in the literature to handle the delivery frequency. The problem with these algorithms is that they require too much detail which is not appropriate at strategic levels.

Speech recognition is a new field in computers and its application in logistics will make a system much more user- friendly. Using a speech recognition technique together with this model will help the modeller or manager to observe the consequence of his instruction.

Expert systems is another field which needs further investigation before it can be utilised in the design of a logistics strategy system. The expert system will need a graphics interface to present different logistics strategies which have been developed.

Research is being carried out to develop a new approach to model development known as structural modelling [Geoffrion 1987]. This new theory

is based on having the same approach to model development for all modelling problems. It is too early to make a judgement on it, however, but if it is successful in other fields then it may prove useful for logistics too. The use of new modelling approaches with developed graphics will enhance logistics strategy modelling.

10.4 Conclusion

In this section some drawbacks of LSM, its critical analysis and recommendations for future research have been presented.

Chapter Eleven

Conclusion

11.0 Introduction

This chapter summarizes the work undertaken during the period of PhD study. It describes the overall conclusions which can be drawn from this research and also discusses the contribution of this dissertation to the academic and the practitioner.

11.1 Summary of Work Undertaken

The main objective of this dissertation was to research into and develop a computer graphic visually interactive decision support system for logistics system modelling at a strategic level.

Chapter one describes the need for a such a model and indicates the approach adopted for development. The structure of the dissertation is outlined.

Chapter two discusses different logistics systems, using as its basis the many definitions which can be found in the existing literature. Three major structures, echelon, direct and flexible are described. The logistics system elements and their functions are discussed in great detail. The decisions involved in designing a logistics system are also discussed. The various channels of distribution are described. A major factor for any logistics system design is the cost. The individual cost for each constituent of a logistics system has been discussed and the interrelationship of these costs and their effect on the total system cost has been explained.

In chapter three, a review of the literature on modelling techniques for distribution systems was described. This chapter begins with a discussion of centre of gravity models and includes physical interactive models such as electric and mechanical analogues. These models were commonly used for distribution system planning before the invention of computers. The second

stage in the literature survey concerns mathematical models. The review starts with simple models such as uncapacitated facility location models and includes:

- uncapacitated plant and warehouse location models;
 - multicommodity uncapacitated plant and warehouse location models;
 - simple multistage plant location models;
 - capacitated facility location models;
 - generalised facility location models;
 - vehicle routing and location models;
 - warehouse location in retail chain models;
- and multicommodity single echelon distribution systems.

This chapter also describes the state of the art in visual interactive modelling. Since one of the aims of this thesis is to develop a decision support system which will be of use in industry, the applications of these models and their benefit to industry are also reviewed in chapter three.

Chapter four discusses the software and hardware used to develop a decision support system. It starts by giving a brief history and evaluation of computer graphics and explains software techniques such as coordinate systems, transformation and clipping. It also describes the hardware such as input and output devices. Included amongst input devices are the keyboard and mouse, and amongst output devices are VDU's and different printer types. Also described are map drawing techniques and map projections and the advantages and disadvantages of different techniques are discussed. This chapter also indicates why Fortran is used in the development of decision support systems. HALO, the graphics system used to develop the LSM is also described in this chapter.

The practical state-of-the-art models which are available to the distribution industry are reviewed in chapter five. Since most of these models are updated

over time, the review starts with models from the 1970's and covers developments up to the late 1980's. Previous market leaders such as DiPS, DSS and Locate are described.

Also discussed are spreadsheet models and their advantages and disadvantages are outlined. The literature review clearly shows that a visually interactive decision support system is missing from the models that are available.

Chapter six discusses mathematical techniques such as heuristics, simulation and optimisation. It describes an ideal technique required by management and what each of the available techniques has to offer. From this discussion is established the basis for the model, which is hybrid rather than being based only on one technique such as simulation, optimisation or heuristics.

Also in this chapter, mainframe and micro computers were compared. The advantages of computer graphics were discussed and the results of a recent survey were presented. The survey clearly shows the benefits of visual interactive models and the advantages of their use. On the basis of previous research, the ideal model for the modelling of logistics systems in the 90's is predicted.

Chapter seven describes the development of an ideal model. It starts by describing an overview of the model including the following:

- how the maps are drawn
- how distance is calculated
- how customers are allocated to depots and transshipment points allocated to depots and depots allocated to source points
- how local delivery cost is calculated
- how trunking cost is calculated
- how warehouse cost is calculated

- how inventory cost is calculated
- how the distance of hazard and barrier is calculated and included in the system
- how the boundaries are drawn around the depots
- how the forecasting is used
- how the search algorithm for best location works

Chapter eight describes the working of the model and the database file it needs to run. It starts with describing each database file format required to run the model and explains the working of each subroutine using data flow diagrams.

Chapter nine describes the validation of the model. It discusses the advantages of the model and its adopted approach for solving real world problems. It also describes the advantages of the visual interactive approach at the formulation and validation stages of logistics strategy modelling. It explains the acceptance by management of the approach and shows how results can be determined for the different distribution systems.

The model has been used for more than five case studies and three of these are described in this chapter.

Chapter ten discusses the drawbacks of LSM and suggests directions for further research for decision support systems in the field of logistics system modelling.

11.2 Overall Conclusions

When this research was started there were no examples of a single decision support system available in the literature or in the market place which had the following qualities:

computer graphically visually interactive;

hybrid in terms of algorithm;
able to run on a personal computer;
able to incorporate a manageable amount of data for logistics strategy modelling.

At this time, for all relevant computer models, the "black box" syndrome had been the major drawback. Managers were often unclear concerning the numbers and results that were produced on computer printout. Relatively few were familiar with modelling their distribution systems, especially on physically interactive models such as electric and mechanical analogues. These models were becoming restricted in use because logistics systems were becoming much more complex. LSM uses computer graphics to show the user his distribution system in terms of the actual models' physical appearance. At the same time, it uses complex mathematical modelling techniques to model the interactions of the logistics system.

The points discussed above have been illustrated by the literature search in chapter five and also through visits to "computers in distribution" exhibitions. The models identified were either operational (using simulation) requiring too much detail to allow for the modelling of logistics systems at the strategic level or they were optimization models, failing to include sufficiently realistic detail for practical and usable strategic modelling. All these models needed mainframe computers to satisfy their computer power requirements.

In chapter six, the preferred technique required by the user to model his distribution system and the advantages of each operational research techniques are described. With existing techniques, no single technique is suitable to solve all major distribution problems. Therefore the algorithm developed for LSM is based on a hybrid approach. It uses optimisation for the allocation of customers and transshipment points, this optimisation being based on total enumeration. It uses computer graphically visual interactive heuristics to search for suitable depot locations.

The comparison of personal computers and mainframe computers is described in chapter six. For any model to be widely available it needs to be able to run on a personal computer. This statement has been verified by a recent survey of Mentzer et al [Mentzer et al 1990]. The survey shows that personal computers are much more widely available in the distribution industry than mainframe computers. In addition, personal computers are much cheaper to use than mainframe computers.

One of the most important aspects of modelling concerns the data that is required to undertake the modelling process. This can be very crucial when, as is often the case, the distribution system is being modelled for future periods. A simulation - only model needs a great deal of data which is not available and has to be estimated. An optimisation - only model can only include limited amounts of detailed data which may not reflect the true nature of the problem. Therefore a model was needed which could provide a realistic solution based on neither too much nor too little detailed data. The dual approach of LSM goes some way towards achieving this objective.

11.3 Research Contribution

This research found that computer models for strategic distribution modelling were not taking advantage of the user friendly power of computer graphics and its abundant availability. The advantages of computer graphically visual interactive modelling has been demonstrated by a survey discussed in chapter six. This approach to modelling is particularly relevant to the application of logistics strategy planning.

Another important stage was to determine the most appropriate hardware on which the model should be developed. The obvious choice was between a personal computer and a mainframe computer. Previously developed models were mostly on mainframe computer as shown by literature search in chapter five. The power of personal computers has continued to increase very rapidly.

An analysis of the pros and cons of the two hardware types indicated that the most logical and effective alternative was likely to be the personal computer, therefore it was decided to develop the model on a personal computer rather than on a mainframe computer.

The model was developed by using Fortran and the Halo graphics package. The graphics used in the development of LSM are machine independent. The model is able to run on any machine which is IBM PC compatible. It operates on different graphics boards such as EGA, VGA, CGA and Hercules. This overcomes the problem of machine dependency which was faced by previous models.

The model was designed to handle manageable numbers of customers, distribution depots, factories and different products. It aims to strike a reasonable balance between the large and small data requirements of simulation - only and optimization - only models as discussed in the previous section.

LSM is the only model available which uses visually interactive computer graphics to search for the best possible location for depots/transshipment points. The procedure shows on the screen the movement of a depot/transshipment point and its associated cost. A number of practical tests indicated that the procedure reliably always located the depot at the least cost point within the given parameters.

LSM is also able to move some depots to their best possible locations whilst leaving the remaining depots in their existing positions. This technique has a major practical use because in many studies there are some depots which will remain at their existing locations, such as factory/depots. Currently available models do not provide this very important facility.

LSM is also the only model at present which separates the boundaries of

servicing areas of distribution depots/transshipment points by visual interactive means. The boundary for each depot/transshipment point is drawn in a different colour. This clearly shows the area each depot/transshipment point is designated to serve.

The model was tested on a number of real world problems in the distribution industry both in the UK and internationally. The model was popular from a users perspective and its approach was widely appreciated by distribution practitioners.

This research established a new concept which is the computer graphically visual interactive heuristic. Computer graphically visual interactive simulation and optimisation procedures are known but no research has been undertaken on the visual interactive heuristic. The heuristic technique is a balance technique in operational research (chapter five). The combination of computer graphics and heuristic provides an excellent opportunity to model the location problem.

This is the first such system to provide all the technical details for graphics, algorithms, hardware and software requirements to develop a logistics decision support system. The Euro Locate system which is currently being marketed widely appears to take a somewhat similar approach but no details are available in the literature or on request from the marketing company.

The current research and development trend suggests that managers will begin to apply and incorporate decision aids on a more routine basis [Bowersox et al 1989]. The increasing power of personal computers coupled with the availability of powerful and user-friendly software such as LSM means that modelling has the potential to become an everyday and low-cost event in logistics strategy planning.

One of the challenges facing logistics managers is to utilise models to help

solve their strategic problems [Mentzer et al 1982]. In this dissertation an attempt is made to define and provide a prototype and very user-friendly logistics strategy model which makes this possible. This model makes best use of the recognised benefits of personal computers , computer graphics and other related developments.

REFERENCES

- Aikens, C.H.III. "The Optimal Design of a Physical Distribution System on a Multi-commodity echelon Network", Ph.D Dissertation, The University of Tennessee, Knoxville, Tennessee, 1982.
- Akine, U "A Branch and Bound Procedure for Solving Warehouse Location Problems with Capacity Constraints ", Ph.D Dissertation, Graduate School of Business Administration, University of North Caroline, 1974.
- Akine, U
and Khumawala, B.M. "An Efficient Branch and Bound Algorithm for the Capacitated Warehouse Location Problem", Management Science, Vol. 23, 1977, pp585-594.
- Alexander, S.R. Marketing Definitions:A Glassy of Marketing terms Chicago: American Marketing Association, 1960.
- Babin, A
Florian, M
James-Lefebvre, L
and Speiss, H "An Interactive Graphics Method for Road and Transit Planning", Publication No 204, Centre De Research Sur Les Transports, Universite de Montreal, Quebec, 1982.
- Balachandran, V
and Jain, S "Optimal Facility Location Under Random Demand with General Cost Structure", Navel Research Logistics Quarterly, Vol. 23, 1976, pp421-436.
- Balinski, M.L. On Finding Integer Solutions to Linear

Programming, Mathematica, Princeton, NJ 1964.

- Ballou, R.H. "Potential Error in the Centre of Gravity Approach to Facility Location", *Transportation Journal*, Winter 1973, pp44-50.
- Ballou, R.H. *Business Logistics Management*, Englewood Cliffs, N.J: Prentice-Hall 1973.
- Ballou, R.H. "Heuristics: Rules of Thumb For Logistics Decision Making", *Journal Of Business Logistics*, Vol. 10, 1, 1989, pp122-132.
- Ballou, R.H. "Estimating and Auditing Aggregate Inventory Level at Multiple Stocking Points", *Journal Of Operations Management*, Vol. 1, 1981, pp143-153.
- Ballou, R.H. "Displan: A Multi-product Plant/Warehouse Location Model With Nonlinear Inventory Costs", *Journal of Operational Management*, Vol. 5,1, Nov. 1984, pp75-90.
- Ballou, R.H. "Broadening and Unifying Market Logistics", *The Logistics Review*, Vol. 6, Winter 1970.
- Barr, R
Glover, F
and Klingman, D "New Optimisation Method for Large Scale Fixed Charge Transportation Problems", *Journal of Operations Research* Vol. 29, 3, 1981, pp488-483.
- Baumol, W.J.
and Wolfe, P.A. "A Warehouse Location Problem" *Operations Research*, Vol. 6, 2, 1958, pp252-263.

- Beardwood, J
Halton, H.J.
Hammersley, M.J.
- "The Shortest Path Through many Points"
Proc. Camb. Phil. Soc. 55, 1958, pp299-327.
- Belardo, S
Duchessi, P
and Seagle, J.P.
- "Microcomputer Graphics in Support of
Vehicle Fleet Routing", Interfaces,
Vol. 15:6, November-December, 1985, pp84-92.
- Baumol, W.J.
- Economic Theory and Operations Analysis,
Printice-Hall 1961.
- Bazjanac, V
- "Interactive Simulation of Building Evacuation
with Elevators", 9th Annual Simulation
Symposium, Florida, March 1976, pp15-29.
- Beckman, N.T.
and Davidson, R.W.
- Marketing 7th Edition New York:
The Ronald Press Company, 1962.
- Bell, C.P.
and Parker, D.C.
- "Development a Visual Interactive Model For
Corporate Cash Management", Journal of
Operations Research Society, Vol. 36, 9,
1985a, pp779-786.
- Bell, P.C.
- "Visual Interactive Modelling in Operational
Research:Successes and Opportunities", Journal of
Operations Research Society, Vol. 36, Sept. 1985,
pp975-982.
- Benders, J.F.
- "Partitioning Procedures for Solving Mixed-
Variables Programming Problems", Numerische
Mathematik, Vol. 4, 1962, pp238-252.

- Bezier, P Numerical Control-Mathematics and Applications, A.R.Forrest (trans) Wiley, London 1972.
- Bhatnagar, S.C. "Locating Social Service Centres Using Interactive Graphics", OMEGA, The International Journal Of Management Science, Vol. 11, 2, 1983, pp201-205.
- Bilde, O
and Krarup, J "Sharp Lower Bounds and Efficient Algorithms for the Simple Plant Location Problem", Annals of Discrete Mathematics, Vol. 1, 1977, pp79-97.
- Blumenfeld, D.E.
Burns, L.D.
Daganzo, C.F.
Frick, M.C.
and Hall,R.W "Reducing the Logistics cost at general Motors", Interfaces Vol. 17:1, January-February 1987, pp26-47.
- Bodily, S.E. "Spreadsheet Modelling has a Stepping Stone", Interfaces, Vol. 16, 5, 1986, pp34-52.
- Bodily, S.E. Modern Decision Making: A Guide to Modelling with Decision Support Systems, McGrew-Hill New York, 1985.
- Bowersox, D.J. "And Index Based Method of Evaluating the Warehouse Location", Transportation Journal, Fall 1963, pp30-34.
- Bowersox, D.J.
and Closs, D.J. Simulation in Logistics: A Review of Present Practice and a Look to the Future ", Journal of Business Logistics, Vol. 10, 1, 1989, pp133-148.

- Bowersox, D.J. "Planning Physical Distribution System with Dynamic Simulation", Journal of Marketing, Vol. 36, January 1972, pp17-25.
- Bowersox, D.J.
Helferich, O.K. "Physical Distribution Planning with Simulation", International Journal Of Physical Distribution, Vol. 2, 1, 1971, pp38-42.
- Bowersox, D.J. Integrated Logistics: A Competitive Weapon
Maynard, MA: Digital Equipment Corporation, 1987.
- Bowersox, D.J. Logistical Management, Second Edition, Collier
Macmillan Publishers London, 1978.
- Bowersox, D.J. "An Analytical Approach to Warehouses Location",
Handling and Shipping, Vol. 2, February, 1962,
pp17-20.
- Brady, S.D.
Rosenthal, R.E.
and Young, D "Interactive Computer Graphics
Solutions of Constrained Minimax
Location Problems", AIIE Trans, Vol. 12, 3, 1983,
pp242-254.
- Brady, S.D.
and Rosenthal, R.E. "Interactive Computer Graphics Solutions
of Constrained Minimax Location Problems", AIIE
Trans, Vol. 12, 3, 1980, pp241-248.
- Brink, E.L.
and De Cani, J.S. "An Analogue Solution of Generalized
Transportation Problem", Proceeding of First
International Conference Operation Research
Oxford 1957.

- Brown, G.G.
Graves, G.W.
Honczarenko, M.D.
- "Design and Operation of a Multi-commodity Production/Distribution System Using Primal Goal Decomposition", *Management Science*, Vol. 33, 11, Nov. , 1987, pp1469-1480.
- Buchanan, J.T.
Mckinnon, K.I.M.
- "An Animated Interactive Modelling System For Decision Support", *Operation Research'87* ,G.K Rand editor Elsevier Science Publishers, B.V. North-Holland, IFORS,1988.
- Burns, L.D.
Hall, R.W.
Blumenfeld, D.E.
and Daganzo, C.F.
- "Distribution Strategy that Minimise Transportation and Inventory Costs", *Journal of Operations Research*, Vol. 33, 1985, pp369-490.
- Burstall, R.M.
Leaver, R.A.
Sussams, J.E.
- "Evaluation of Transport Costs for and Alternative Factory Site", *Operational Research Quarterly*, Vol. 13, 4, 1962, pp345-54.
- Buxton, G
Quayle, N
- "Application of a new approach to depot delivery areas" , *International Journal of Physical Distribution*, June, 1971, pp117-121.
- Cabot, A.V.
and Erenguc, S.S.
- "Some Branch-and-Bound Procedure for Fixed-Cost Transportation Problems", *Naval Research Logistics Quarterly*, Vol. 3, 1984, pp145-154.
- Carlisle, D.P.
Nickerson, K.S.
Probst, S.B.
- "A Turnkey Microcomputer-Based Logistics Planning System", *Interfaces*, Vol. 17:4, July-August, 1987, pp16-26.

Rudolph, D
Sheffi, Y
and Powell, W.B.

Chen, S
and Saigal, R
"A Primal Algorithm for Solving a
Capacitated Network Flow Problem with
Additional Linear Constraints", Networks, Vol. 7,
1977, pp59-79.

Christofides,N
"Use of vehicle routing and scheduling system in
strategic distribution planning", Scandinavian
Journal of Administration, Vol 2, No 7, 39-51 1981.

Christopher, M.G.
The Strategy of Distribution Management, Gower
Publishing Company London, 1985.

Christopher, M.G.
"Logistics in its Marketing Context European",
Journal of Marketing, Vol. 6, 2, 1972, pp117-123.

Clark, M.P.
"Bricks and Mortar Plc ", Distribution Studies
Unit, Cranfield Institute Of Technology, November
1988.

Cokelez, S
and Burns, J.R.
"Distribution Systems- Warehouse
Location and Capacity" OMEGA International
Journal of Management Science, Vol. 17, 1, 1989,
pp45-51.

Coons. S
"An Outline of the Requirements for a Computer
Aided Design System", AFIPS, SJCC, Vol. 23, 1963,
pp299-304.

- Coons, S.A. "Computer Graphics and Innovative Engineering Design", *Datamation*, May, 1966.
- Crookes, J.G.
and Valentine, B "Simulation in Microcomputer",
Journal of the Operational Research Society, Vol. 33, 9, 1982, pp855-858.
- Cunningham, K
and Schrage, L "Optimisation Models With Spreadsheet
Programs", Graduate School of Business,
University of Chicago, 1985.
- Daganzo, C.F. "The Lengths of Tours in Zones of Different
Shapes", *Transportation Research*, Vol B18, 1984,
pp135-146.
- Daganzo, C.F. "The Distance Traveled to Visit N Points with a
Maximum of C Stops per Vehicle: An Analytic
Model and an Application ", *Transportation
Science*, Vol 18,1984a, pp331-350.
- Daganzo, C.F.
and Newell, G.F. "Configuration of Physical Distribution
Networks", *NETWORKS*, Vol. 16, 1986, pp113-132.
- Dantzig, G.B. *Linear Programming and Extensions*, Princeton,N.J
Princeton University Press, 1963.
- Das, C
and Verma, A "A Heuristic Method For Finding
the Optimal Location and Size of Facilities with
Variable Demands", *Logistics and Transportation
Reviews*, Vol. 21, 2, 1985, pp115-131.
- Davis, J "Distribution System Analysis", *International*

Journal of Physical Distribution and Material Management, Vol. 8, 2, 1977, pp74-88.

- De Sanctis, G "Computer Graphics as Decision Aids: Direction for Research", Decision Science, Vol. 15, 1984, pp463-487.
- Dearing, P.M.
and Newruck, F.C. "A Capacitated Bottleneck Facility Location Problem", Management Science, Vol. 11, 1979, pp1093-1104.
- DiPS DiPS Distribution Planning Systems,
7 Merganser Way, Kidderminster, Worcestershire.
- Donnay, J.D.H. "Spherical trigonometry", New York: Interscience, 1945.
- Drysdale, J.K.
and Sandiford, P.J. "Heuristic Warehouse Location- A Case History Using a New Method", CORS Journal, Vol. 7, 1, March 1969, pp45-61.
- Efroymsen, M.A.
and Ray, T.L. "A Branch and Bound Algorithm for Plant Location", Operations Research, Vol. 14, 1966 pp361-368.
- Eilon, S
and Deziel, D.P. "Siting a Distribution Centre an Analogue Computer Application", Management Science, Vol. 12, 6, February 1966, ppB245-B254.
- Eilon, S
Watson-Gandy, C.D.T.
Christofides, N Distribution Management,
Charles Griffin & Company Limited,
London,1971.

- Eldredge, D.L. "A Cost Minimisation Model for Warehouse Distribution Systems", Interfaces, Vol. 12, 4, August 1982, pp113-119.
- Elson, D.G. "Site Location via mixed integer programming", Operations Research Quarterly, Vol. 23, 1972, pp31-43.
- Erlenkotter, D "A Dual-Based Procedure for Uncapacitated Facility Location", Operations Research, Vol. 26, 1978, pp992-1009.
- Feldman, E
Lehrer, F.A.
and Ray, T.L. "Warehouse Location under Economies of Scale", Management Science, Vol. 12, 9, 1966, pp670-684.
- Fiddy, E
Bright, J
and Hurrion, R.D. "SEE WHY: Interactive Simulation on the Screen", Proceeding of Institute of Mechanical Engineer, C293/81, 1982, pp167-172.
- Figgens, J.M.
and Thompson, S.A. "A Methodology for Developing Sensitivity Analysis on Specified DOD Logistics System Report GSA/SM/73-7, U.S.A.F Air University, Air Force Institute Of Technology, Wright-Patterson Airforce Base Ohio, June 1973.
- Formm, G
Hamilton, W.L.
and Hamilton, D.E. "Federally Supported Mathematical Models", Survey and Analysis, U.S Government Printing Office, Washington, DC, 1974.
- Fisher, M.L. "Interactive Optimization", Annals of Operations

Research, 1986 ,pp541-556.

- Fisher, M
Greenfield, A
and Thompson, K "Real World Experience with an Interactive Graphics Colour Interface for Vehicle Routing Models", Presentation ORSA/TIMS Joint National Meeting, Orlando, 1983.
- Garbini, J.L.
Lembersky, M.R.
Chi, U.H.
and Hehnen, M.T. "Merchandise Design Using Simulation with Graphical Animation", Weyerhaeuser Research and Development, WTC 2E2, Tacoma, Washington, 1983.
- Garfinkel, R.S.
and Rao, M.R. " The Bottleneck Transportation Problem", Navel Research Logistics Quarterly, Vol. 18, 1972, pp465-472.
- Gass, S.I. "Documenting of Computer-Based Model" , Interfaces Vol. 14:3, May-June 1984,pp84-93
- Geisler, M.A.
and Steger, W.A. The Combination of Alternative Research Techniques in Logistics Systems Analysis", Management Technique 1963.
- Geoffrion, A.M.
and Graves, G.V. "Multi-commodity Distribution System Design by Benders Decomposition", Management Science, Vol. 20, 1974, pp822-844.
- Geoffrion, A.M.
and McBride, R "Lagrangean Relaxation Applied to the Capacitated Facility Location Problem" ,AIIE Transactions, Vol. 10, 1978, pp40-47.
- Geoffrion, A.M. "Management Support System",

- Powers, R.F. The Wharton Magazine, Vol. 5, 3, Spring 1981, pp26-35.
- Geoffrion, A.M. "Strategic Distribution System Planning:
Graves, G.W. A Status Report", Chapter 7 in A.Hax (ed.),
and Lee, S Studies in Operations Management North
Holland/American Elsevier (1978)
- Geoffrion, A.M. "A Portable Management Support
Graves, G.W. System for Distribution Planning" ,
and Lee, S Unpublished Paper Graduate School of
Management ,University of California, Las Angles,
1979.
- Geoffrion, A.M. "Better Distribution Planning with computer
Models", Harvard Business Review, Vol. 54, 4,
July-August 1976, pp92-99.
- Gizelis, A.G. " A Simplified Algorithm for Depot Location
and Jesus-Emmanuel, S Problem", OMEGA--International Journal Of
Management Science, Vol. 8, 1980, pp465-472.
- Glover, F "Interactive Decision Software and
McMillian, C Computer Graphics for Architectural and Space
and Novick, B Planning", Annals of Operations Research, 1985.
- Glover, F " An Integrated Production, Distribution
Jones, G and Inventory Planning System",
Karney, D Interfaces, Vol. 9, 5,
Klingman, D November 1979, pp21-35.
and Mote, J

- Hung-Lang, T "GRASPERS, A Graphics Decision Support System: Its Development and Applications", Ph.D Dissertation, The University of Nebraska- Lincoln, 1986.
- Hurrion, R.D. "The design,use and required facilities of an interactive visual computer simulation language to explore production planning problems",Ph.D Thesis University of London 1976
- Hurrion, R.D. "An Interactive Visual Simulation System for Industrial Management", European Journal of Operational Research, Vol. 5, 1980 pp86-93.
- Hurrion, R.D. "Visual Interactive Modelling", European Journal of Operational Research, Vol. 23, 3A, ,1986, pp281-287.
- Hurrion, R.D. "Implementation of Visual Interactive Consensus Decision Support System", European Journal of Operational Research, Vol. 20, 1985, pp138-144.
- Hurrion, R.D. "An Investigation of Visual Interactive Simulation Method Using the Job Shop Scheduling Problem", Journal of the Operational Research Society, Vol. 29, 11, 1978. pp1085-1093.
- Jacobsen, S.K.
and Madsen, O.B.G. " A Comparative Study of Heuristics for a Two-level Routing-Location Problem", European Journal of Operational Research, Vol. 5, 1980, pp378-387.

- Jones, C.B. "Database design for variable-scale worldwide cartography" Presented at computer graphics '85: Online Publications, Pinner, UK, 1985, 117-129.
- Jones, M.J. "Decision Analysis Using Spreadsheet", European Journal of Operational Research, Vol. 26, 1986, pp385-400.
- Karkazis, J
and Boffey, T.B. "The Multi-commodity Facility Location Problem", Journal of Operational Research Society, Vol. 32, 1981, pp803-814.
- Kaufman, A
and Hanani, M.Z. "Converting a Batch Simulation Program to an Interactive Program with Graphics", Simulation, Vol. 36, 4, 1981, pp125-131.
- Kaufman, L
Eede, M.V.
and Hansen, P "A Plant and Warehouse Location Problem", Operations Research Quarterly, Vol. 28, 1977, pp547-554.
- Keast, D.N. Survey of Graphics Input Devices for Computer-Aided Design, Machine Design, Vol. 3, August 1967 pp 114.
- Keen, P.G.W.
and Scott, M.S. Morton Decision Support System: An Organizational Perspective, Addison-Wesley, Reading Mass 1978.
- Keffer, K.B. "Easy way to determine the centre of Distribution" Food Industries, 6, 1934, pp450-451.
- Kennington, J.L. Algorithms for Network Programming,

- and Helgason, R.V. John Wiley and Sons New York, 1980.
- Khumawala, B.M.
and Whybark, D.C. "Solving the Dynamic Warehouse Location Problem," International Journal Of Physical Distribution Vol 6, 1976, pp238-251.
- Khumawala, B.M. "An Efficient Branch and Bound Algorithm for Warehouse Location Problem ", Management Science, Vol. 18, 1972, B718-B731.
- Khumawala, B.M.
and Neebe, A.W. "A Note on Warszawski's Multi-commodity Location Problem", Journal Of Operational Research Society, Vol. 29, 1978, pp171-172.
- Kirkpatrick, P
and Bell, P.C. "Visual Interactive Modelling in Industry: Results from a Survey of Visual Interactive Model Builders" Interfaces 19:5, September- October 1989, pp71-79.
- Klincewicz, G
Luss, H
Rosenberg, E "Optimal and Heuristic Algorithms and for Multiproduct Uncapacitated Facility Location", European Journal of Operational Research, Vol. 26, 1986, pp251-258.
- Kochman, G.A.
and McCallum, Jr.C.J. "Facility Location Models for Planning a Trans Atlantic Communications Network", European Journal of Operational Research, Vol. 6, 1981, pp205-211.
- Kornhauser, A.L. "Exploring Transportation Problem Using Interactive Computer Graphics", Computer and Graphics, Vol. 11, 3, 1987, pp231-239.

- Kuehn, A
and Hamburger, M.J. "A Heuristic Program for Locating Warehouses"
Management Science, Vol. 9, July 1963, pp643-666.
- Landry, M
Malouin, J
and Oral, M "Modal validation in Operations Research",
European Journal of Operational Research,
Vol 14, 3, 1983, pp207-220.
- Lapalme, G
Cormier, M
and Mallette, C "A Colour Graphics System for Interactive
Routing", Presentation ORSA/TIMS
Joint National Meeting, Orlando, 1983.
- Laporte, G
and Dejax, P.J. "Dynamic Location-routing Problem",
Journal of Operational Research Society, Vol. 40, 5,
1989, pp471-482.
- Laporte, G
and Nobert, Y "An Exact Algorithm for Minimising Routing
and Operating Costs in Depot Location" European
Journal of Operational Research, Vol. 6, 1981,
pp224-226.
- Lawrence, R.M.
Pengilly, P.J. "The Number and Location of Depots Required for
Handling Products for Distribution to Retail Stores
in South-east England ", Operational Research
Quarterly, Vol 20, 1969, pp23-32.
- Le Blanc, L.J.
and Wong, R.T. "A Heuristic Approach for Large Scale
Discrete Stochastic Transportation-Location
Problems", Computer and Mathematics with
Applications, Vol.3, 1977, pp87-94.
- Lembersky, M.R. "Decision simulators speed implementation

- and Chi, U.H. and improve operations" Interfaces Vol,14 NO 4, (July-August), 1984, pp1-15.
- Lewis, R.J. A logistical System for Marketing Analysis, Cincinnati: South-Western Publishing Co, 1970.
- Lin, S "Heuristic programming as an aid to Network Design" Networks Vol. 5, 1975, pp33-43.
- Litwhiler,D.W "Large region location problems", Ph.D. Dissertation, The University of Oklahoma, 1977.
- Magee, J.F. Physical Distribution System, McGraw-Hill Book Company New York, 1967.
- Magee, J.F. Modern Logistics Management,
Copacino, W.C. John Wiley & Sons Inc New York, 1985.
Rosenfield, D.B.
- Markland, R.E. "Analyzing Geographically Discrete Warehousing Network By Computer Simulation", Decision Science, Vol. 4, 1973.
- Markland, R.E. "Production Distribution Planning
and Newett, R.J. in a Large Scale Commodity Processing Network ", Decision Sciences, Vol. 7, 1976, pp579-594.
- Marks, D.H. "Facility Location and Routing Models in Solid Waste Collection System" Ph.D Thesis,The Johns Hopkin University, November 1969.
- Melamed, A "Visual Simulation: The performance Analysis

- and Morris, R.J.T. "Workstation", Computer, August, 1985, pp87-94.
- Mentzer, T.J. "Microcomputer-Based Distribution-Planning Models", International Journal of Physical & Material Management, Vol. 15, 7, 1985.
- Mentzer, T.J. " Microcomputer versus Mainframe Usage in
Schuster, P.C. Logistics", Logistics and Transportation
Roberts, J.D. Review, Vol. 26, 2, 1990.
- Mentzer, T.J. "Computer Modelling in Logistics: Existing Models
Schuster, D.A. and Future Outlook", Journal of Business Logistics
Vol. 3, 1, 1982, pp1-55.
- Miller, I.M. "Computer Graphics For Decision Making"
Harvard Business Review November-December
1969, pp121-132.
- Mohammed, H.A.C. "Distribution System Design: A Problem Solving
Approach", Ph.D Dissertation, Case Western
University, 1982.
- Morris, J.G. "Extend to Which Certain Fixed-Charge Depot
Location Problem can be Solved by L.P", Journal of
Operations Research Society, Vol 29. 1978, pp71-
76.
- Mossman, F.H. Logistics in Distribution Systems,
and Morton, N Allyn and Bacon Inc Boston, 1965.
- Mossman, F.H. Logistics System Analysis,
Bankit, P University Press of America

- and Helferich, O.K. Washington D.C, 1977.
- Nambier, J.M. " A Comparative Study of Heuristics
Gelders, L.F. and for a Two-Level Routing-Location Problem",
Van Wassenhove, L.N. European Journal of Operations Research, Vol. 5 ,
1980, pp378-387.
- Nambier, J.M. " A Large Scale Location-Allocation
Gelders, L.F. and Problem in the Natural Rubber Industry",
Van Wassenhove, L.N. European Journal of Operations Research, Vol. 6,
1981, pp183-189.
- Nauss, R.M. "An Improved Algorithm for the Capacitated
Facility Location Problem", Journal of Operational
Research Society, Vol. 29, 1978, pp1195-1201.
- Naylor, T.H. Computer Simulation Techniques,
Balentfy, J.L. John Wiley & Sons Inc New York, 1966.
Burdick, D.S.
and Chu, K
- Neebe, A.W. "An Improved Algorithm for the Multi-commodity
and Khumawala, B.M. Location Problem", Journal Of Operational
Research Society, Vol. 32, 1981, pp143-169.
- Negelhout, R.V. "A Cost Operating Approach to Multistage
and Thompson, G.L. Location Allocation", European Journal Of
Operational Research, Vol. 6, 1981, pp149-161.
- Spielburg, K "Algorithms for Simple Plant Location Problem
with some Side Conditions", Operations Research
Vol. 17, 1969, pp85-111.

- Newman, W.M.
and Sproull, R.F. Principle of Interactive Computer Graphics, McGraw Hill New York, 1973.
- Palm, J "Moving pictures show simulation to user", Simulation Vol. 29 (b), 1977, pp240-249.
- Perl, J
and Sirisoponsilp, S "Distribution Network; Facility Location Transportation and Inventory", International Journal of Physical Distribution and Material Management, 1989, pp18-26.
- Polya, G "Mathematical Discovery Vol II Wiley, New 1965.
- Polya, G How to Solve It, Princeton University Press, Princeton, 1947.
- Polya, G "Mathematical Discovery Vol I Wiley, New York 1962.
- Pools van
Amstel, M.J. "Physical Distribution Cost Control" International Journal of Physical Distribution Management & Material Management, Vol. 17, 2, 1987.
- Powers, R.F. "Optimisation Models for Logistics Decisions" Journal Of Business Logistics Vol. 10, 1, 1989, pp106-121.
- Prince, M.D. Interactive Graphics of Computer-Aided Design, Addison-Wesley Reading Mass, 1971.
- Raugh, T.H. "The PC Model: A Strategic Planning Tool",

- and Rust, J Council of Logistics Management Annual Meeting, Atlanta, Georgia, September 1987.
- ReVelle, C "Central Facilities Location "
and Swain, R.W. Geographical Analysis, Vol. 2, 1970, pp30-42.
- Robinson, E.P. "Multi-Activity Uncapacitated Facility Location Problem: A New Tool for Logistics Planning", Journal of Business Logistics, Vol. 10, 2, 1989, pp159-179.
- Robinson, A.H. Elements of Cartography (3rd ed),
and D.Sale, R John Wiley and Sons Inc New York, 1969.
- Rosenfield, D.B. "The Retail Facility Location Problem, A Case Study", Journal of Business Logistics, Vol. 8, 2, 1989.
- Rosenfield, D.B. "Logistics Planning and Evaluation Using
Copacino, W.C. "What-if" Simulation", Journal of Business
and Payne, E.C. Logistics, Vol. 6, 2, 1985 pp89-109.
- Rushton, A.S. Hand Book of Logistics and Distribution
and Oxley, J Management, Kogan Page limited London, 1989.
- Sadik, C "Integrated Mathematical and Financial Modelling with Application to Product Distribution, Warehouse Location and Capacity Problems", Ph.D Dissertation, Texas Tech University, 1985.
- Saunders, W.B. Reading in Physical Distribution Management,
Edited by Bowersox, D.J, LaLonde,B.J, Smykay

E,W Macmillan Company New York, 1969.

- Saw,R "JIT-What does it means for warehouse operations ? ", Distribution Studies Unit, Cranfield Institute of Technology ,Beds, England, 1990.
- Saw, R
and Cooper, S "Computer Simulation of Large Soft Drink Warehouse", Warehousing & Distribution Software Directory 1990, National Material Handling Centre ,Cranfield Institute of Technology Cranfield, Beds, England, 1990.
- Schmidt,A.H "Computer Mapping: Application of Automated Mapping", Datamation , 45-58, June 1978.
- Scott, A.J. "Location-Allocation Systems: A Review " Geographical Analysis, Vol. 2, 1,January 1970.
- Shepard, S.W. "DISPATCH: Downsized Interactive System for Planning Assignments to Trucks Using Combinatorial Heuristics " Exxon Corporation CCS Department,P.O. Box 153, Florham Park, New Jersey, USA, 1983.
- Shycon, H.N.
and Maffei, R.B. "Simulation- Tool for Better Distribution Harvard Business Review, Vol. 39, November-December, 1960, pp65-75.
- Site Synergy Distribution Systems Limited Synergy House, Lisle Street Loughborough LE11 OAY. 1987.

- Sorenson, B "Interactive Distribution Planning", Doctoral Dissertation, Institute of Mathematical Statistics and Operations Research, Technical University of Denmark, 1986.
- Stadtfeld, N Information Display Concepts, Beaverton : Tektronix 1968.
- Stein, D.M. "Scheduling Dial-a-Ride Transportation Systems, Transportation Science, Vol 12, 1978, pp232-249.
- Sulonen, R.K. "On-Line Simulation With Computer Graphics", On-Line 72, 1972.
- Sutherland, I SKETCHPAD " A Man-machine Graphical Communication System", AFIPS, SJCC, Vol. 23, 1963, pp329-346.
- TCHA, D " A Branch-and-Bound Algorithm for the Multi-level Uncapacitated Facility Location Problem", European Journal of Operational Research, Vol. 18, 1984, pp35-43.
- and Lee, B
- Tomlin, J.A. "An Improved branch and bound method for integer programming", Operations Research, Vol. 19, 1971, pp1070-1075.
- Tonge, F.M. "The use of Heuristic Programming", Management Science, Vol. 7, 1961, pp231-237.
- Van Roy, T.J. "Solving a Distribution Problem with Side Constraints", European Journal of and Gelders, L.F.

Operations Research, Vol. 6, 1981, pp61-66.

- Tufte, E.R. The Visual Display of Quantitative Information
Graphics Press Cheshire, 1983.
- UMPIRE "Unified Mathematical System Incorporating
Refinement and Extension", User's Guide
Publication S00037-00-00, Computer Science
Corporation, Los Angeles, 1970.
- Wagner, H.M. Principles of Operational Research with Application
to Managerial Decisions, Prentice-Hall, Englewood
Cliffs, New Jersey, 1969.
- Vergin, C.R. "An algorithm and Computational Procedure
and Rogers, J.D. for Locating Economic Facilities",
Management Science, Vol. 13, February 1967,
ppB240-B254.
- Waller, A.G. "Computer System for Distribution Planning"
International Journal of Physical Distribution &
Material Management, Vol. 13, 7, 1983, pp48-59.
- Warszawski, A. "Multi-dimension Location Problems", Operational
Research Quarterly, Vol. 24, 1973, pp165-179.
- Watson-Gandy, C.W.T. " Planning Warehouse Locations", Economic
Development Committee for the Distribute on
Trade, National Economic Development Office ,
Milbank, London, 1967.
- Wills, G "The Analysis of European Distribution

Magrill, L
and Cooper, L

Systems", International Journal of
Physical Distribution, Vol. 3, 1, 1972/73, pp21-42.

Winter, F.W.

" Market Segment Using Modelling and
Lotus 1-2-3", Interfaces, Vol. 19:6, November-
December, 1989, pp83-94.

Webb, M.H.J,

"Cost functions in the location of depots for
multiple delivery journeys." Operational Research
Quarterly Vol.19, 1968, pp311-320.

"OPHELIE/LP Addendum: Mixed Integer
Capability", OPHELIE/LP System Publication, No
D0001507032, Control Data Corporation,
Minneapolis,1970.

Poligami User's Manual, S.I.A Ltd., 23 Lower
Belgrave Street London.S.W.1 1970.

"Mathematical Programming System Extended,
Mixed Integer Programming", Manual SH20-0908,
IBM Corporation, White Plains, New York.

APPENDIX A

A1.1

Robinson's model has the following mathematical formulation [Robinson 1989]:

$$\text{Min } Z = \sum_{i \in I} FF_i Z_i + \sum_{i \in I} \sum_{j \in J} FA_{ij} Y_{ij} + \sum_{i \in I} \sum_{j \in J} \sum_{k \in K} C_{ijk} X_{ijk} \quad (1)$$

Subject to

$$\sum_{i \in I} X_{ijk} = 1 \quad j \in J, k \in K, i \in I \quad (2)$$

$$-Z_i + Y_{ij} \leq 0 \quad j \in J, i \in I \quad (3)$$

$$-Y_{ij} + X_{ijk} \leq 0 \quad j \in J, k \in K, i \in I \quad (4)$$

$$Z_i = (0, 1) \quad i \in I \quad (5)$$

$$Y_{ij} = (0, 1) \quad j \in J, i \in I \quad (6)$$

$$0 \leq X_{ijk} \leq 1 \quad j \in J, k \in K, i \in I \quad (7)$$

Z_i Binary decision variable for facility i ;

where $Z_i = 1$ if facility i is opened and 0 otherwise;

Y_{ij} Binary decision variable for assigning activity j to facility i

where $Y_{ij} = 1$ if j is assigned to i and 0 otherwise;

X_{ijk} Decision variable that indicates the fraction of demand in Zone k that is served from activity j in facility i ;

FF_i fixed cost of establishing facility i ;

FA_{ij} fixed cost for assigning activity j to facility i ;

C_{ijk} cost of serving all of the customer zone k's demand for activity j from facility i, where

$$C_{ijk} = T_{ijk} d_{jk} \quad (8)$$

T_{ijk} Total variable costs for supplying one unit of activity j to customer zone k from facility i. This includes the per unit costs for (1) processing activity j at facility i, and (2) the in-bound and out-bound transportation costs for supplying zone k with activity j from facility i;

and

d_{jk} demand for activity j in zone k.

The three terms in the objective function equation (1) represent the fixed costs of opening facilities, the fixed costs of assigning activities to facilities, and the variable costs of serving customers demand respectively. Constraints set (2) insures that demand for all activities in all zones is served. Constraints set (3) prevents the assignment of an activity to a facility unless the facility is established. Similarly, constraints set (4) prevents the demand for an activity in a zone from being served from a facility unless the activity is assigned to the facility. Constraints (5),(6) and (7) force the decision variables to take on feasible solution values.

A1.2

Akinc et al proposed the following eight branching rule [Akinc et al 1977]:

Integrality of z

Max z: select the free warehouse which has the largest z from the set of warehouses having fractional Z;

Min z: select the free warehouse which has the smallest z from the set of warehouses having fraction Z;

Where

$$Z_k = 1 - \frac{X_{k,m+1}^*}{S_k} \quad k \in K \quad (9)$$

where

$X_{k,m+1}^*$ is the unused capacity of warehouse k in the solution to the bounding problem;

Penalty Functions:

- 1 Largest Omega--select the free warehouse having the largest omega.
Select Z_k :

$$\Omega_k - F_k = \text{Max}_{i \in K_2} (\Omega_i - F_i) \quad (10)$$

- 2 Smallest Omega--select the free warehouse having the smallest omega.
Select Z_k :

$$\Omega_k - F_k = \text{Min}_{j \in K_2} (\Omega_j - F_j) \quad (11)$$

Where

$$\Omega_i = \text{Max}_{0 \leq X_{ij} \leq D_{ij}} (\sum_j W_{ij} X_{ij} | \sum_j X_{ij} \leq S_i) \quad (12)$$

and

$$W_{ij} = V_j - C_{ij} \quad (13)$$

and

V_j is the dual variable corresponding to the demand constraints to the customer j ;

W_{ij} can be thought of as a marginal decrease in the transportation cost brought about by making X_{ij} basic;

- 3 Largest Delta -- select the free warehouse having the largest delta.
Select Z_k :

$$\Delta_k - F_k = \underset{i \in K_2}{\text{Max}} (\Delta_i - F_i) \quad (14)$$

- 4 Smallest Delta -- select the free warehouse having the smallest delta.
Select Z_k :

$$\Delta_k - F_k = \underset{i \in K_2}{\text{Min}} (\Delta_i - F_i) \quad (15)$$

Where Δ_k is defined to be the difference between the optimal transportation costs, with an augmented configuration derived by opening all free warehouses and adding to the configuration a set of dummy warehouses with the capacity constraints relaxed, and the optimal transportation costs of the augmented configuration, but with warehouse k closed.

Feasibility:

- 1 Largest Capacity -- Select the free warehouse with the largest capacity.
Select Z_k :

$$C_k = \underset{i \in K_2}{\text{Max}} C_i \quad (16)$$

- 2 Smallest Capacity -- select the free warehouse with the smallest capacity. Select Z_k :

$$C_k = \underset{i \in K_2}{\text{Min}} C_i \quad (17)$$

Where

$$C_i = \text{Min} (S_p \sum_{j \in J_i} D_j) \quad i \in K_2, J_i = \{j | w_{ij} > 0\} \quad (18)$$

A1.3

Marks' model mathematically expressed as follows [Marks 1969]:

$$\text{Minimise} \quad \sum_{i \in I} F_i Z_i + \sum_{i \in I} \sum_{j \in J} C_{ij}^* X_{ij}^* + \sum_{i \in I} \sum_{k \in K} C_{ik}^{**} X_{ik}^{**} \quad (19)$$

Subject to the constraints;

$$\sum_{i \in I} X_{ik}^{**} \leq S_k \quad k \in K \quad (20)$$

$$\sum_{i \in I} X_{ij}^* = \sum_{i \in I} X_{ik}^{**} \quad i \in I \quad (21)$$

$$\sum_{i \in I} X_{ik}^{**} \leq Q_i y_i \quad i \in I \quad (22)$$

$$D_{ju} \geq \sum_{i \in I} X_{ij}^* \geq D_{j,l} \quad j \in J \quad (23)$$

$$X_{ij}^* \quad X_{ki}^{**} \quad (24)$$

are non negative integers

$$Z_i = \{0,1\}$$

where:

i,j,k are element of sets I,J and K .

$Z_i = 1$ if the i 'th facility is built
 $= 0$ otherwise

X_{ij}^* = flow of material from facility i to sink j

X_{ki}^{**} = flow of material from source k to intermediate point i .

$$C_{ij}^* = C_{ij} + R_j =$$

unit cost associated with a transfer of material from facility i to sink j

C_{ij} = unit shipping cost from facility i to sink j

R_j = unit variable cost associated with using sink j

$C_{ki}^{**} = c'_{ki} + T_k + V_i =$ unit cost associated with transfer of material from source k to facility i .

c'_{ki} = unit shipping cost from source k to facility i

T_k = unit variable cost associated with using source k .

V_i = unit variable cost associated with using source i .

F_i = fixed charge for establishing facility i

S_k = amount supplied at source k

D_j = upper bound on amount demanded at sink j

D_{1j} = lower bound on amount demanded at sink j

Q_i = capacity of the i th facility

A1.4

Geoffrion et al's Generalised Capacitated Facility Location (GCFL) model mathematically formulated as follows [Geoffrion et al 1978]:

$$\text{Minimize } \sum_{i \in I} \sum_{j \in J} C_{ij} X_{ij} + \sum_{i \in I} F_i Z_i \quad (25)$$

Subject to

$$V_i Z_i \leq \sum_{j \in J} D_j X_{ij} \leq V_i^- Z_i \quad i \in I \quad (26)$$

$$\sum_{j \in J} a_{ij} X_{ij} + \sum_{j \in J} b_{ij} z_{ij} = r_i \quad i \in I \quad (27)$$

$$\sum_{i \in I} X_{ij} = D_j \quad j \in J \quad (28)$$

$$X_{ij} \geq 0 \quad i \in I, \quad j \in J \quad (29)$$

$$Z_i \in (0,1) \quad i \in I \quad (30)$$

The generalization consists of permitting lower as well as upper bounds on the volume constraints on each location, enforced by constraints (26), and allowing for an arbitrary set of linear constraints (27) to be imposed on the x and z variables.

A1.5

Rosenfield's model mathematically formulated as follows [Rosenfield 1989]:

Let

X_{kj} = Amount from distribution centre or store zone j ;

Z_{kj} = $\{0,1\}$ 1 if store j assigned to distribution centre k otherwise it equal to 0;

C_{kj} = Cost from distribution centre k to store zone j;

$$C_{kj} = T_{kj} + I_{kj} + \frac{\sum_i a_{ij} S_{ik}}{\sum_i a_{ij}} \quad (31)$$

$$S_{ik} = \min_k (T_{ik} + I_{ik} + T_{kk}^* + I_{kk}^*) \quad (32)$$

where

a_{ij} = Amount required from source i for store or store zone j;

$$B_j = \sum_i a_{ij} \quad (33)$$

A_k = Capacity at distribution centre k;

T_{kj} = Unit transit cost, k to j;

S_{ik} = Total inbound unit cost, vendor i to DC k;

$$T_{kk}^*, I_{kk}^* = \quad (34)$$

is equal to transship transit and pipeline inventory cost from DC k to DC k'.

Then the optimisation problem is

$$\text{Minimize } \sum C_{kj} X_{kj} \quad (35)$$

Such that

$$\sum_j X_{kj} \leq A_k \quad (36)$$

$$\sum_k X_{kj} \geq \sum_i a_{ij} - B_j \quad (37)$$

Total store requirement

$$X_{kj} \geq Z_{kj} \sum_i a_{ij} \quad (38)$$

$\sum_k Z_{kj} = 1$, and Y_{kj} integer

The first two terms of C_{kj} are the direct unit transit and inventory costs. The third term is the weight average value of inbound costs from the vendors to the distribution centre for that store. The tabulation of S_{ik} simply takes the minimum of direct and transshipment costs.

A1.6

Elson's model is formulated mathematically as follow [Elson 1972]:

$$\sum_{i \in I} \sum_{j \in J} \sum_{k \in K} C_{ijk}^s X_{ijk} + \sum_{i \in I} \sum_{k \in K} \sum_{l \in L} \sum_{s \in S} C_{ikls}^i Y_{ikls} + \sum_{i \in I} \sum_{j \in J} \sum_{k \in K} C_{ijk}^h X_{ijk} \quad (39)$$

$$+ \sum_{k \in K} (C_k^o + C_k^w) z_k + \sum_{k \in K} (C_k^e z_k + \sum_{k \in K} (C_k^f w_k - \sum_{k \in K} (C_k^x + C_k^o) z_k) \quad (40)$$

Subject to

$$\sum_{k \in K} X_{ijk} \leq A_{ij} \quad i \in I, j \in J \quad (41)$$

$$\sum_{k \in K} Y_{ikls} \geq D_{ils} \quad i \in I, l \in L, s \in S \quad (42)$$

$$\sum_{j \in J} X_{ijk} = \sum_{l \in L} \sum_{s \in S} Y_{ikls} \quad i \in I, k \in K \quad (43)$$

$$\sum_{i \in I} \sum_{j \in J} X_{ijk} < (C_k z_k' - C_k z_k'' + w_k) \quad k \in K \quad (44)$$

$$(F_k - E_k) z_k - w_k \geq 0 \quad (45)$$

$$z_k' + z_k'' \leq 1 \quad k \in K'' \quad (46)$$

$$\sum_{i \in I} \sum_{j \in J} X_{ijk} < C_k z_k + w_k \quad k \in K'' \quad (47)$$

$$F_k z_k - w_k \geq 0 \quad k \in K'' \quad (48)$$

$$X_{ijk} \geq 0 \quad i \in I, j \in J, k \in K \quad (49)$$

$$Y_{ikls} \geq 0 \quad i \in I, k \in K, l \in L, s \in S \quad (50)$$

$$z_k, z'_k, z''_k \in (0,1) \quad k \in K \quad (51)$$

Where i, j, k, l and s index commodities, plants, distribution centres (DC's) customer zones, and service level respectively, I, J, K, L and S are the relevant sets and

X_{ijk} and Y_{ikls} = the unit flows;

z_k, z'_k, z''_k = the binary variable controlling the establishment the expansion by a minimum amount or the closure respectively of DC k ;

w_k = the number of extra units of expansion over the minimum of DC k ;

A_{ij}, D_{il} = supply and demand respectively

C_k = the normal capacity of DC k ,

$E_k(F_k)$ = the minimum (maximum) increase in capacity in DC k .

C^a_{ijk}, C^t_{ikls} = unit transportation cost.

C^w_k, C^o_k = fixed establishment and operating costs respectively for DC k .

C^e_k, C^f_k = the cost of minimum and further expansion respectively for DC k .

C^x_k = the cost saving derived from closing DC k

C^h_{ik} = the variable throughput cost of commodity i at DC k and

K' = the set of candidate new DC's

and $K = K' U K''$

The objective function comprises terms which reflect source-to-DC transportation costs, DC-to-customer transportation costs, DC throughput costs, DC establishment costs, DC expansion costs (minimum + further) and the saving derived from DC closures. Constraint (41) and (42) are the standard supply and demand constraints and (43) are conservation of flow conditions. Constraints (44) ensure that the total flow into distribution centre does not exceed the capacity of the DC (45) prevents further expansion of a DC from taking place unless the minimum expansion has first taken place. (46) preclude the simultaneous expansion and closure of an DC, (47) requires that new warehouse be opened with sufficient capacity and (48) permit further expansion from those DC which already exist.

A1.7

The Geoffrion et al proposed model has the following mathematical formulation [Geoffrion et al, 1974]:

$$\text{Minimize } \sum_{i \in I} \sum_{j \in J} \sum_{k \in K} \sum_{p \in P} C_{ijkp} X_{ijkp} + \sum_{j \in J} [F_j z_j + v_j + \sum_{k \in K} \sum_{p \in P} D_{kp} y_{jk}] \quad (52)$$

Subject to

$$\sum_{j \in J} \sum_{k \in K} X_{ijkp} \leq S_{ip} \quad i \in I, p \in P \quad (53)$$

$$\sum_{i \in I} X_{ijkp} = D_{kp} y_{jk} \quad p \in P, j \in J, k \in K \quad (54)$$

$$V \min_j z_j \leq \sum_{k \in K} \sum_{p \in P} D_{kp} y_{jk} \leq V \max_j z_j \quad j \in J \quad (55)$$

$$X_{ijkp} \geq 0 \quad i \in I, j \in J, k \in K, p \in P \quad (56)$$

$$y_{jk}, z_j \in (0,1) \quad j \in J, k \in K \quad (57)$$

where p, i, j, k are index commodities, plants, DC's, and customers respectively; V_j is the unit variable cost of throughput for DC located at j ; $V \min_j$ ($V \max_j$) is the minimum (maximum) allowable throughput for a Distribution Depot at site j , and y_{jk} is a binary variable which represents the assignment of customer k to a Distribution Depot at site j . Constraints (53) place an upper bound on supply, by commodity, at each source. Constraints (54) not only require that demand be satisfied, but that it be satisfied by the distribution centre to which the customer as been assigned. Constraints (55) together with (56) ensure that demand will only be satisfied by open distribution centres. Constraints (57) require that the total Distribution Centre throughput not exceed the upper and lower bounds for the Distribution Centre's which are open.

A1.8

Geoffrion et al's refinement has the following formulation [Geoffrion et al, 1978,1979]:

$$\text{Minimize } \sum_{i \in I} \sum_{j \in J} \sum_{k \in K} \sum_{p \in P} C_{ijkp} X_{ijkp} + \sum_{j \in J} [F_j Z_j + \sum_{k \in K} \sum_{b \in B_k} \sum_{p \in P_k(b)} V_{jp} D_{kp} y_{jkb}] \quad (58)$$

$$+ \sum_{j \in J} [p_j' v_j' + p_j'' v_j''] \quad (59)$$

Subject to

$$S_{ip} \leq \sum_{j \in J} \sum_{k \in K} X_{ijkp} \leq S_{ip}'' \quad p \in P, i \in I \quad (60)$$

$$\sum_{i \in I} X_{ijkp} - D_{kp} y_{jkb} \quad j \in J, b \in B_k, p \in P_{k(b)} \quad (61)$$

$$\sum_{j \in J} y_{jkb} = 1 \quad k \in K, b \in B_k \quad (62)$$

$$V_j' z_j - v_j' \leq \sum_k \sum_{b \in B_k} \sum_{p \in P_{k(b)}} \beta^p D_{kp} y_{jkb} \leq V_j'' z_j + v_j'' \quad j \in J \quad (63)$$

$$v_j', v_j'' \geq 0 \quad j \in J \quad (64)$$

and (56) - (57)

where

B_k = the set of bundle indices for customer k

$P_k(b)$ = the set of commodity indices corresponding to bundle b for customer k.

β^p = burden factor for commodity p used in calculating DC throughput.

- P'_j, P''_j penalty rates for violating lower (upper) throughput limits for distribution centre j .
- $S'_{ip} (S''_{ip})$ = lower and (upper) limits on plant capacity for plant i .
- $v'_j (v''_j)$ = amount of underflow (overflow) at Distribution Centre j .

A1.9

Benders decomposition reduces the level of difficulty in the following way:

$$\text{Minimize } [\sum_{j \in J} (F_j Z_j + \sum_{k \in K} \sum_{b \in B_k} \sum_{p \in P_k(b)} V_{jp} D_{kp} y_{jkb})] \quad (65)$$

$$+ \sum_{j \in J} (p'_j v'_j + P''_j v''_j) + \text{Min}(\sum_{i \in I} \sum_{j \in J} \sum_{k \in K} \sum_{p \in P} C_{ijkp} X_{ijkp}) \quad (66)$$

Subject to (60)-(61)

If z , y , v' and v'' are held temporarily fixed, (66) together with (56) and (61)-(62) define a classical multi-commodity transportation problem which decomposes on commodity. If a solution x to this transportation problem is held fixed temporarily and the vectors z, y, v' and v'' are permitted to vary, (66) together with (56) and (61)-(64) defines a mixed integer programming problem.

The Benders algorithm is based on the convergence of upper and lower bounds obtained from the oscillatory solution to the two problems. With the binary variables held fixed (that is, fixed configuration) the commodity-independent transportation sub-problems are solved for optimal transportation costs and flows. These sub-problems constitute restrictions on the Multi-distribution system since not all of variables are free to vary. Consequently any sub-problem solution is an upper bound on the multi-distribution system. The iteration solution of these sub-problem with different configurations generates a sequence (non-monotonic) of such upper

bounds. Each time a sub-problem is solved, the optimal solution is used to solve the master problem for a new configuration. Specifically the master problem is (66) with

$$\text{Min} \sum_{ijp} C_{ijp} X_{ijp} \quad (67)$$

replaced by

"Max $\sigma(h)$ " and subject to (57) and (61)-(64), where $\sigma(h)$ is the value of the optimal objective function of the h^{th} transportation sub-problem solved. The sense of the optimisation is "maximize" instead of "minimize" since it is actually the transportation duals which are solved rather than the primal. The reason for this is that the solution space of the transportation dual is configuration-independent. Such is not the case with primal. The master problem is a relaxation of multi-commodity distribution system and each additional transportation sub-problem solved contributes a new constraint of the form $\sigma \geq \sigma(h)$ to the master. These constraints are called Benders cuts and because each new cut reduces the size of the solution space of the master problem, successive solutions constitute a monotonically increasing sequence of lower bounds on the multi-distribution system. The master problem is solved for a new configuration and the procedure repeated. Termination occurs when the upper and lower bounds converge to an ϵ -gap.

A1.10

Markland's model is mathematically formulated as follows [Markland 1973]: In the following equation, c, p, t are element of sets C, P and T , m^* is not equal to m and w^* is not equal to w .

Customer demand (product flow) can be defined by the following equation:

$$\dot{D}_{c,p}^t = \sum_{m \in M} SMC_{p,m,c}^t + \sum_{w \in W} SWC_{p,w,c}^t \quad (68)$$

Field warehouse inventory levels can be defined by the following set of equations:

$$IW_{p,m}^t = IW_{p,w}^{t-1} + \sum_{m \in M} SMW_{p,m,w}^{t-1} + \sum_{w \in W} SWW_{p,w,w}^{t-1} - \sum_{w \in W} SWW_{p,w,w}^{t-1} - \sum_{c \in C} SWC_{p,w,c}^{t-1} \quad (69)$$

Manufacturing facility inventory levels can be defined by the following set of equations:

$$IM_{p,m}^t = IM_{p,m}^{t-1} + PM_{p,m}^t + \sum_{m \in M} SMM_{p,m,m}^{t-1} - \sum_{m \in M} SMM_{p,m,m}^{t-1} - \sum_{w \in W} SMW_{p,m,w}^{t-1} - \sum_{c \in C} SMC_{p,m,c}^t \quad (70)$$

Production and inventory capacity constrain is defined by the following equation:

$$IW_{p,w}^t \leq ICW_{p,w} \quad p \in P, w \in W, t \in T \quad (71)$$

(field warehouse inventory capacity cannot be exceeded.)

$$PM_{p,m}^t \leq ICM_{p,m} \quad p \in P, m \in M, t \in T \quad (72)$$

(manufacturing facility warehouse inventory capacity cannot be exceeded.)

$$PM_{p,m}^t \leq PCM_{p,m} \quad p \in P, m \in M, t \in T \quad (73)$$

(manufacturing facility production capacity cannot be exceeded.)

Finally the total cost of Distribution can be defined as follows:

$$\begin{aligned}
 \text{Cost} = & \sum_{t \in T} \sum_{p \in P} [\sum_{m \in M} \sum_{w \in W} SMW_{p,m,w}^t CMW_{p,m,w} + \sum_{m \in M} \sum_{c \in C} SMC_{p,m,c}^t \\
 & CMC_{p,w,c} + \sum_{w \in W} \sum_{c \in C} SWC_{p,w,c}^t CWC_{p,w,c} + \sum_{w \in W} SWW_{p,w,w}^t CWW_{p,w,w} \\
 & - \sum_{w \in W} SWW_{p,w,w}^t CWW_{p,w,w} - \sum_{m \in M} SMM_{p,m,m}^t CMM_{p,m,m} - \sum_{m \in M} SMM_{p,m,m}^t CMM_{p,m,m} \\
 & - \sum_{m \in M} VCM_{p,m} Y_m (\sum_{w \in W} SMW_{p,m,w}^t + \sum_{c \in C} SMC_{p,m,c}^t + \sum_{m \in M} SMM_{p,m,m}^t \\
 & + \sum_{m \in M} SMM_{p,m,m}^t) + \sum_{w \in W} VCW_{p,w} Z_w (\sum_{c \in C} SWC_{p,w,c}^t + \sum_{w \in W} SWW_{p,w,w}^t \\
 & + \sum_{c \in C} BC_{c,p}^t + \sum_{c \in C} OC_{c,p}^t) + \sum_{m \in M} FCM_m + \sum_{w \in W} FCW_w \tag{74}
 \end{aligned}$$

Subject to Equations (68), (69), (70) and Constraints (71), (72), and (73) with all product flows defined as being zero or positive.

Where variable define as follows:

p = product

m = manufacturing facility

w = warehouse

c = customer

$SMW_{p,m,w}^t$ = amount of product p shipped from manufacturing facility m to field warehouse w in time period t ;

$SMC_{p,m,c}^t$ = amount of product p shipped from manufacturing facility m to customer c in time period t ;

$SWC_{p,w,c}^t$ = amount of product p shipped from field warehouse w to customer c in time period t ;

SWW_{p,w,w^*}^t = amount of product p shipped from field warehouse w to field warehouse w^* in time period t ;

SMM_{p,m,m^*}^t = amount of product p shipped from manufacturing facility m to manufacturing facility m^* in time period t ;

$CMW_{p,m,w}$ = per unit cost of shipping product p from manufacturing facility m to field warehouse w (constant over time);

$CMC_{p,m,c}$ = per unit cost of shipping product p from manufacturing facility m to customer c (constant over time);

$CWC_{p,w,c}$ = per unit cost of shipping product p from field warehouse w to customer c (constant overtime)

CWW_{p,w,w^*} = per unit cost of shipping product p from field warehouse w to field warehouse w^* (constant over time)

CMM_{p,m,m^*} = per unit cost of shipping product p from manufacturing facility m to manufacturing facility m^* (constant overtime);

$IW_{p,w}^t$ = inventory of product p at field warehouse w in time period t ;

$IM_{p,m}^t$ = inventory of product p at manufacturing facility warehouse m in time period t ;

$ICW_{p,w}$ = inventory capacity for product p at field warehouse w (constant overtime);

$ICM_{p,m}$	=	inventory capacity for product p at manufacturing facility warehouse m (constant overtime);
$PM_{p,m}^t$	=	production of product p at manufacturing facility in time period t;
$CM_{p,m}$	=	production capacity for product p at manufacturing facility m (constant over time);
FCM_m	=	fixed cost of operating manufacturing facility warehouse m over $t=1,\dots,T$;
FCW_w	=	fixed cost of operating field warehouse w over $t=1,\dots,T$;
$VCM_{p,m}$	=	variable unit warehousing cost for product p in manufacturing facility warehouse m;
$VCW_{p,w}$	=	variable unit warehousing cost for product p in field warehouse w;
Y_m	=	{0,1} 1 if the manufacturing facility warehouse m is utilised, 0 otherwise.
Z_w	=	{1,0} 1 if field warehouse w is utilized, 0 otherwise;
$D_{c,p}^t$	=	demand of customer c for product p in time period t;
$BC_{c,p}^t$	=	back ordering cost for customer c for product p in time period t;
$OC_{c,p}^t$	=	order shifting cost for customer c for product p in time period t;

A1.11

Perl et al's model is mathematically represented as follows [Perl et al 1989]:

Total distribution cost = Sum of cost [warehousing, trunking, delivery, in-transit inventory, plant and distribution centre stocks, safety stock];

The warehouse cost is equal to;

$$WC_j = W_j + v_j D_j \quad (75)$$

Where

- WC_j = Average total warehousing cost at DC location "j";
 W_j = Fixed cost at DC location "j";
 v_j = Unit variable cost at DC location j;
 D_j = average total Demand allocated to DC "j" ;

Unit trunking cost is related to shipment size as follows:

$$t = a + \frac{b}{Q} = a + \frac{bF}{X} \quad (76)$$

Where

- t = unit trunking cost;
 Q = shipment size;
 X = total quantity shipped;
 F = Shipping Frequency ;
 a and b = non-negative constant;

Based on equation (75), the total trunking cost of shipments between plant "i" and DC "j" on transportation option "m" is give by:

$$CT_{ijm} = t_{ijm} X_{ijm} = \left[a_{ijm} + \frac{b_{ijm}}{Q_{ijm}} \right] * X_{ijm} \quad (77)$$

$$= [a_{ijm} + \frac{b_{ijm} F_{ijm}}{X_{ijm}}] * X_{ijm} \quad (78)$$

$$= a_{ijm} X_{ijm} + b_{ijm} F_{ijm} V_{ijm} \quad (79)$$

Where

CT_{ijm} = Total trunking cost for shipments between plant "i" and "j" by transportation option "m";

t_{ijm} = unit trunking cost for shipping between plant "i" and DC "j" by transportation option "m";

X_{ijm} = total quantity shipped from plant "i" to DC "j" by transportation option by "m" ;

F_{ijm} = shipment frequency of transportation option "m" from plant "i" to DC "j";

a_{ijm}, b_{ijm} = non-negative constants which characterise transportation option "m" from plant "i" to DC "j" ;

Delivery cost is equal to;

$$CD_{jk} = d_{jk} * Y_{jk} \quad (80)$$

where

CD_{jk} = Delivery cost from DC "j" to demand point "k";

d_{jk} = unit delivery cost from DC "j" to demand point "K";

Y_{jk} = quantity shipped from DC "j" to demand point "k";

The inventory cost has three component; i) in-transit inventory, ii) cycle stock cost, and iii) safety stock. They represented the transit stock:

$$I_{ijm} = L_{ijm} * X_{ijm} \quad (81)$$

Where

I_{ijm} = in-transit stock for shipments form plant "i" to DC "j" by transportation option by "m";

L_{ijm} = average lead-time for shipment for plant "i" to DC "j" by transportation option "m";

Using equation (81),the average carrying cost of in-transit inventory can be represented as follow:

$$CI_{ijm} = c_m I_{ijm} = c_m L_{ijm} * X_{ijm} \quad (82)$$

where

CI_{ijm} = carrying cost of in-transit inventory for shipment from plant "i" to DC "j" by transportation option "m";

c_m = unit carrying cost for in-transit inventory per unit-transit time on transportation option "m".

Perl et al assumed a constant production rate and the average stock held at a plant is equal to one-half the average quantity shipped and outbound flow from distribution centre is uniform, then represented the cycle stock at the plant by the following equation [Perl et al 1989]:

$$CCP_{ijm} = 0.5 c p_i Q_{ijm} = \frac{0.5 c p_i X_{ijm}}{F_{ijm}} \quad (83)$$

Where

CCP_{ijm} = Cycle stock cost at plant "i" associated with shipments to DC "j"
by transportation option "m"
 $c p_i$ = unit carrying cost at plant "i"

The cycle stock cost at DC is given by:

$$CCW_{ijm} = 0.5 c w_j Q_{ijm} = \frac{0.5 c w_j}{F_{ijm}} \quad (84)$$

where , $c w_j$ = unit inventory carrying cost at DC "j";

The safety Stock cost was represented as follow:

$$SSC_j = \left[\frac{q}{\beta - p} \right] * \left[\frac{\sum_i \sum_m F_{ijm} \sqrt{L_{ijm} \sigma_j^2 + D_j^2 v_{ijm}^2}}{\sum_i \sum_m F_{ijm}} \right] \quad (85)$$

where

SSC_j = Safety Stock cost at distribution centre "j";
 β = allowed probability of stock out during order cycle;
 σ_j = standard deviation of demand at DC "j";
 v_{ijm} = standard deviation of replenishment lead-time from plant "i" to DC "j" by transportation option m
p and q are non-negative parameters.

USER DOCUMENT

A major reason given for model failure or poor utility is the lack of proper documentation [Gass 1984]. The purpose of this section is to provide non-programmer users with an understanding of the model's purposes, capabilities and limitations so they may use it accurately and effectively. This section will enable the user to understand the overall structure and logic of the model, input data requirements, output formats, and the interpretation and use of the results.

U1. START UP

Enter Number of factory files.

1

Enter Name for factory file.

Enter Number of depot files.

1

Enter Name for depot file.

Enter Number of customer files.

1

Enter Name for customer file.

Enter Name for cost file.

Enter Number of Hazard files.

1

Enter Number of Barrier files.

1

U2. USING THE INTERACTIVE GRAPHICS FEATURES

Please make sure that the Num Lock is on.

The cursor may be moved by using the arrow keys for a major jump . For a small jump, use the side arrow keys with the Num Lock on.

When deleting or moving a depot or a customer, the cursor should be moved to the centre of the picture. In the case of a factory it should be moved to the bottom left hand side of the factory's image.

U3. THE OPTIONS

OPTIMISE DEPOT LOCATIONS
MODIFY DATA
MANUAL ALLOCATION
DISPLAY/PRINT DATA
RESTART ALLOCATION
ZOOM IN
PRINT SCREEN
QUIT

The VDU image is given in figure U1.

U4. OPTIMISE DEPOT LOCATIONS

ANY DEPOT NOT TO OPTIMISE

This allows you to decide which, if any, depot location you do not wish to be optimised by the Model. The screen image is given in figure U2.

If you use 'NO' then it will optimise all those depots which are being utilised to serve the customer.

If you use 'YES' then you interactively highlight the first depot you do not

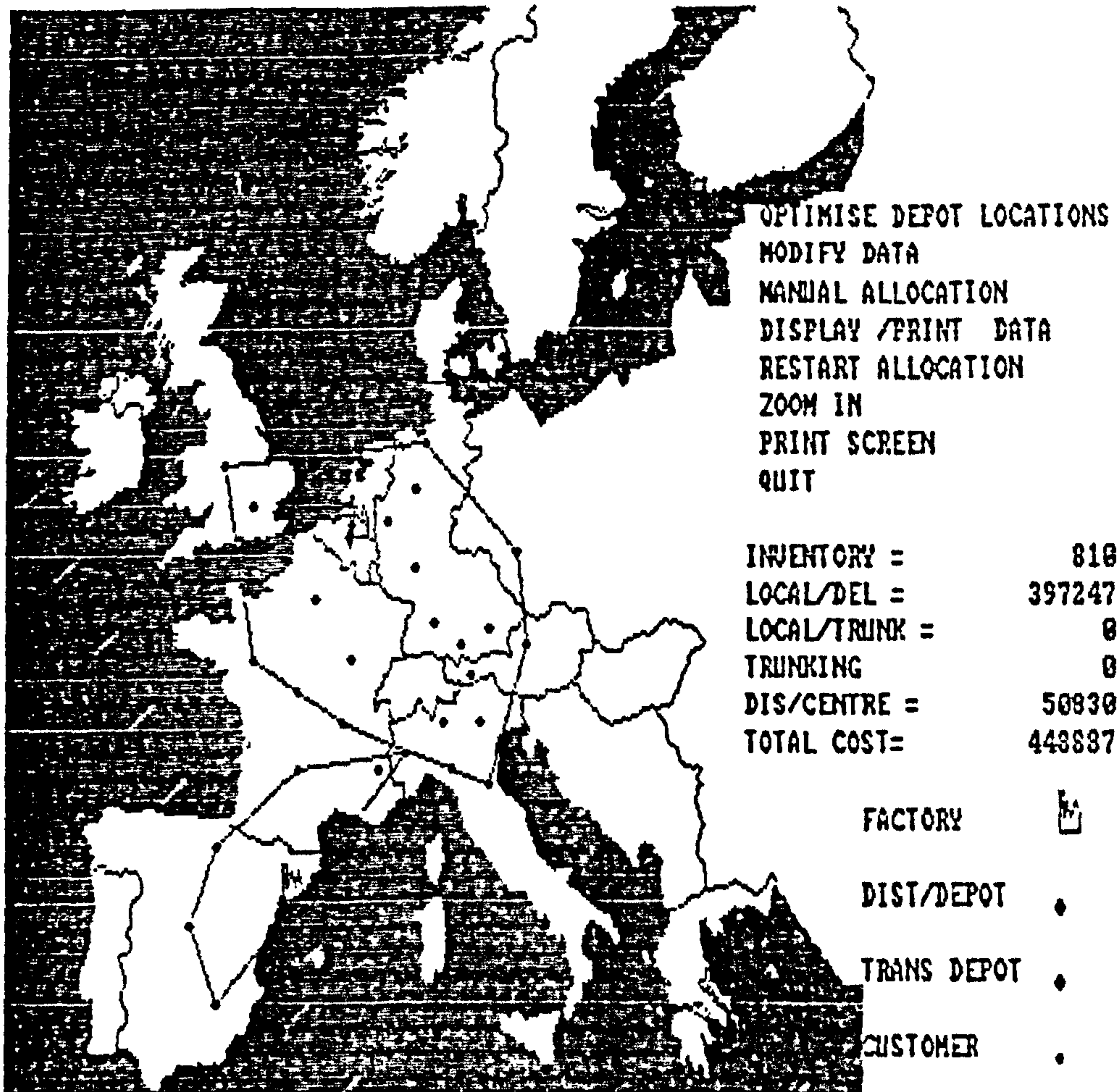

Figure U1.

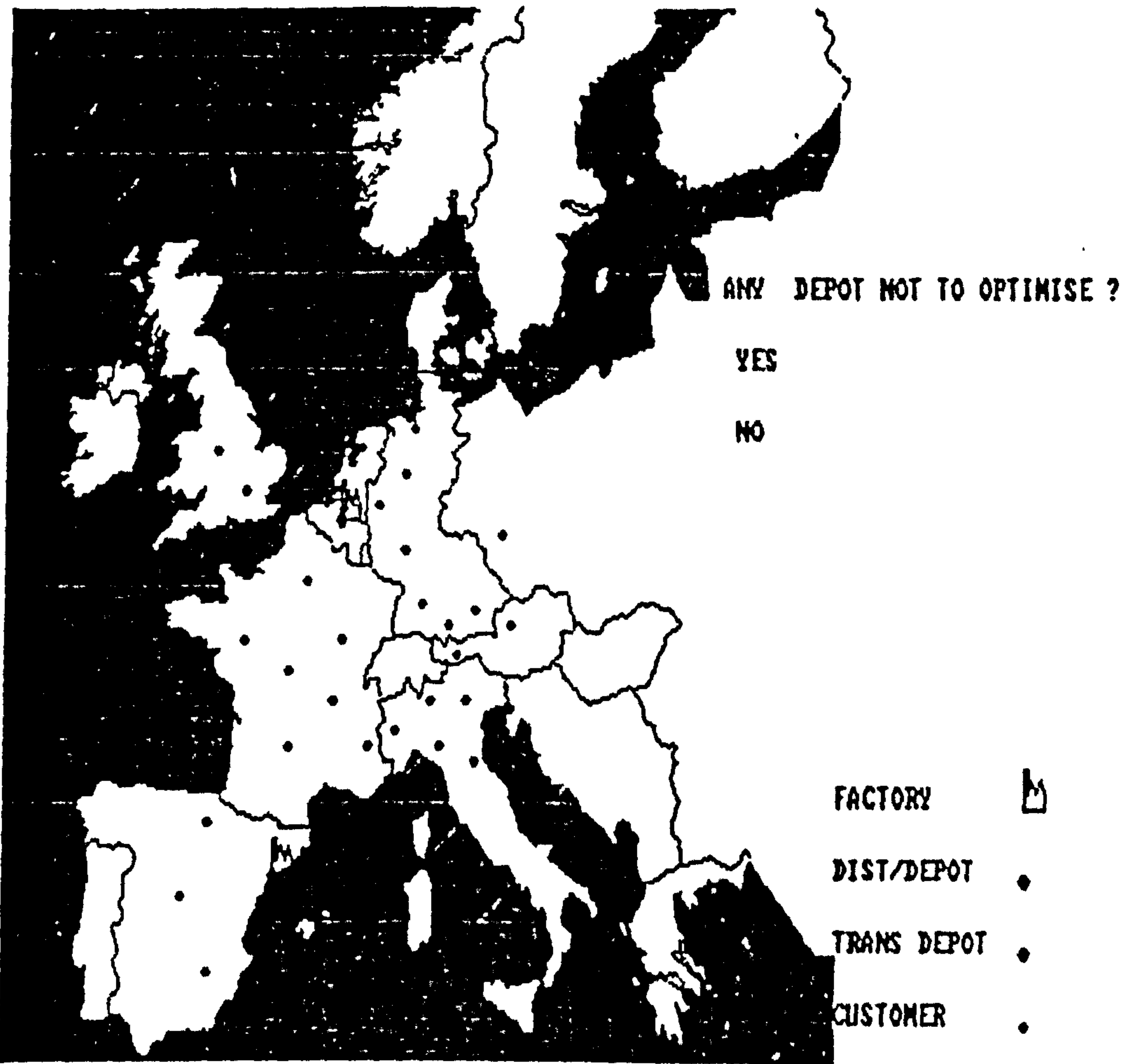

Figure U2.

wish to be optimised. If the depot is highlighted correctly then it will display the following:

CONTINUE

QUIT

CONTINUE for another depot to be highlighted or

QUIT to proceed to the next instruction.

If the depot is not found then the following message will be displayed on the screen:

DEPOT NOT FOUND

CONTINUE

QUIT

CONTINUE for another depot to be highlighted or

QUIT to proceed to the next instruction.

The optimising screen is given in figure U3. The depot is able to move on to five different places and screen shows the costs of those five places.

U5. MODIFY DATA

CHANGES IN FACTORY

DEPOTS

CUSTOMERS

DEMAND

COST

QUIT

The image of the screen is given in figure U4.

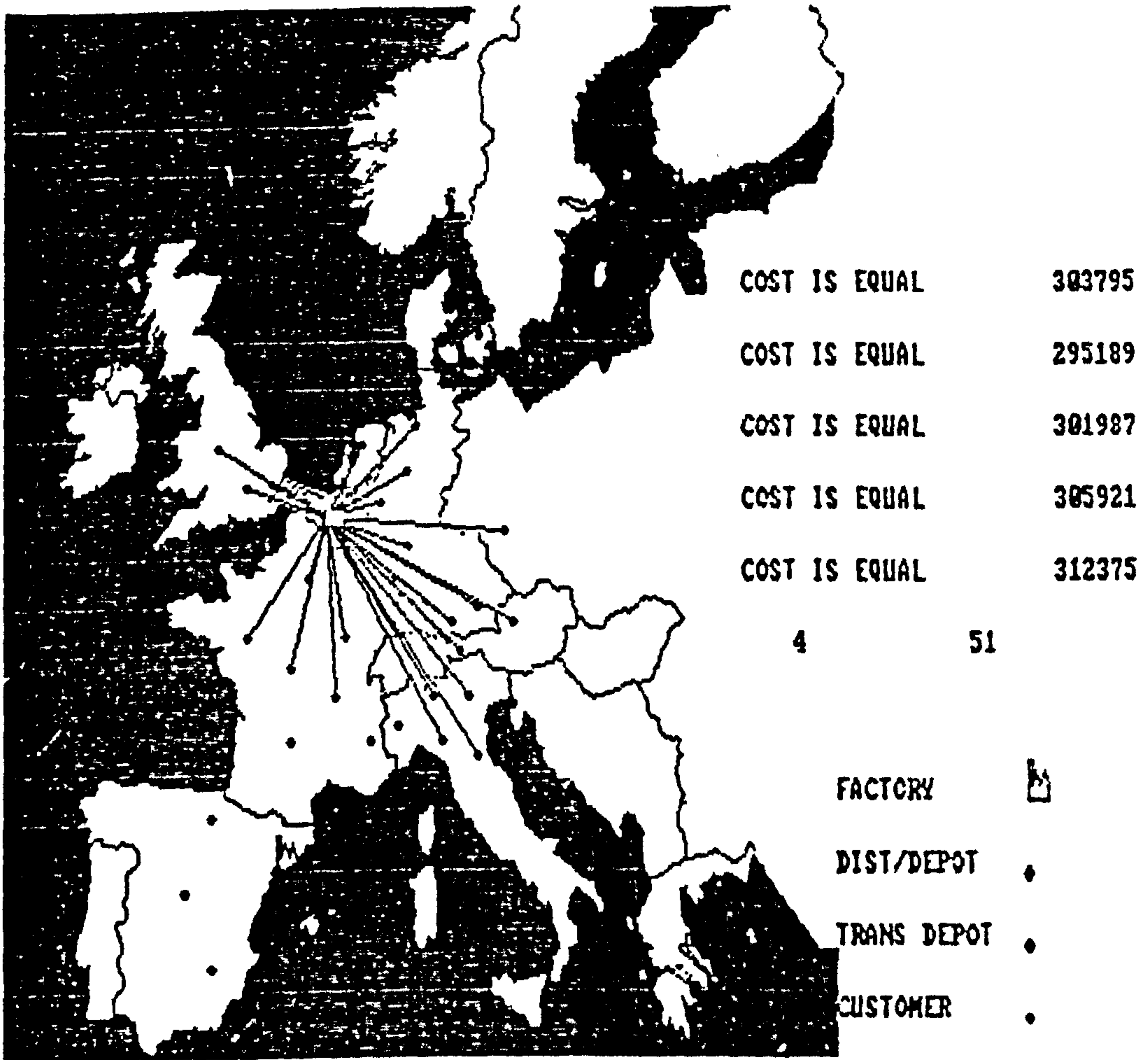

Figure U3.

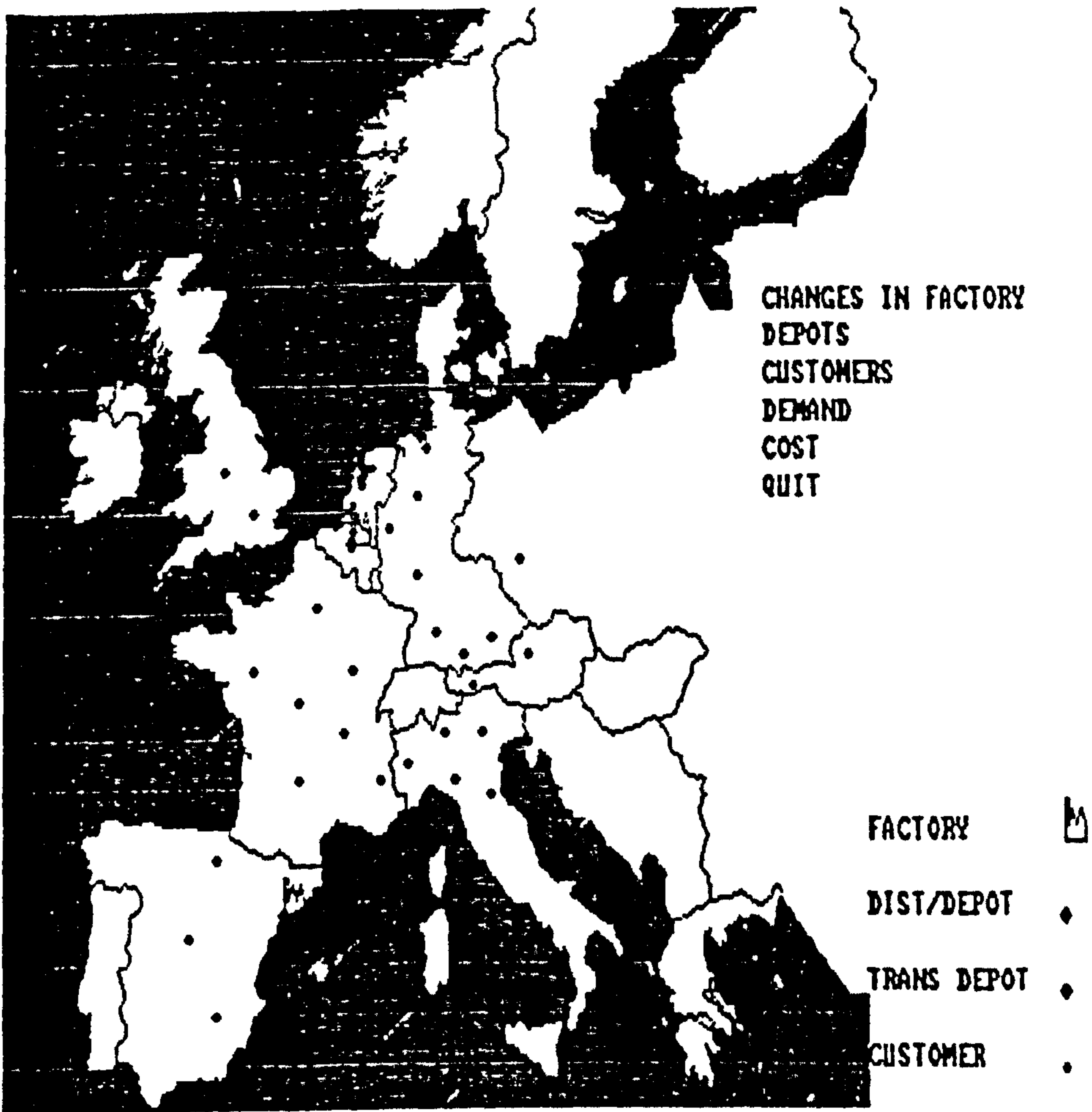

Figure U4.

U5.1 CHANGES IN FACTORY

ADD

DELETE

MOVE

QUIT

The image of the screen is given in figure U5.

ADD:

The add is used to add a factory to the system.

Move the cursor using the arrow keys as required.

ENTER FACTORY NAME

The name may be up to twenty characters long.

(eg MILTON KEYNES)

ENTER FACTORY PROD/CAPACITY

Production capacity must be less than 1 million and greater than 100 in the basic unit that is being utilised in modelling.

ENTER PRODUCT NUMBER

BETWEEN 1 AND 10

Enter 1 if products are not being differentiated.

DELETE:

The delete is used to delete a factory from the system. Indicate the factory to be deleted by moving the cursor using the arrow keys as required. If a factory is not highlighted properly then the following will appear on the screen:

FACTORY NOT FOUND

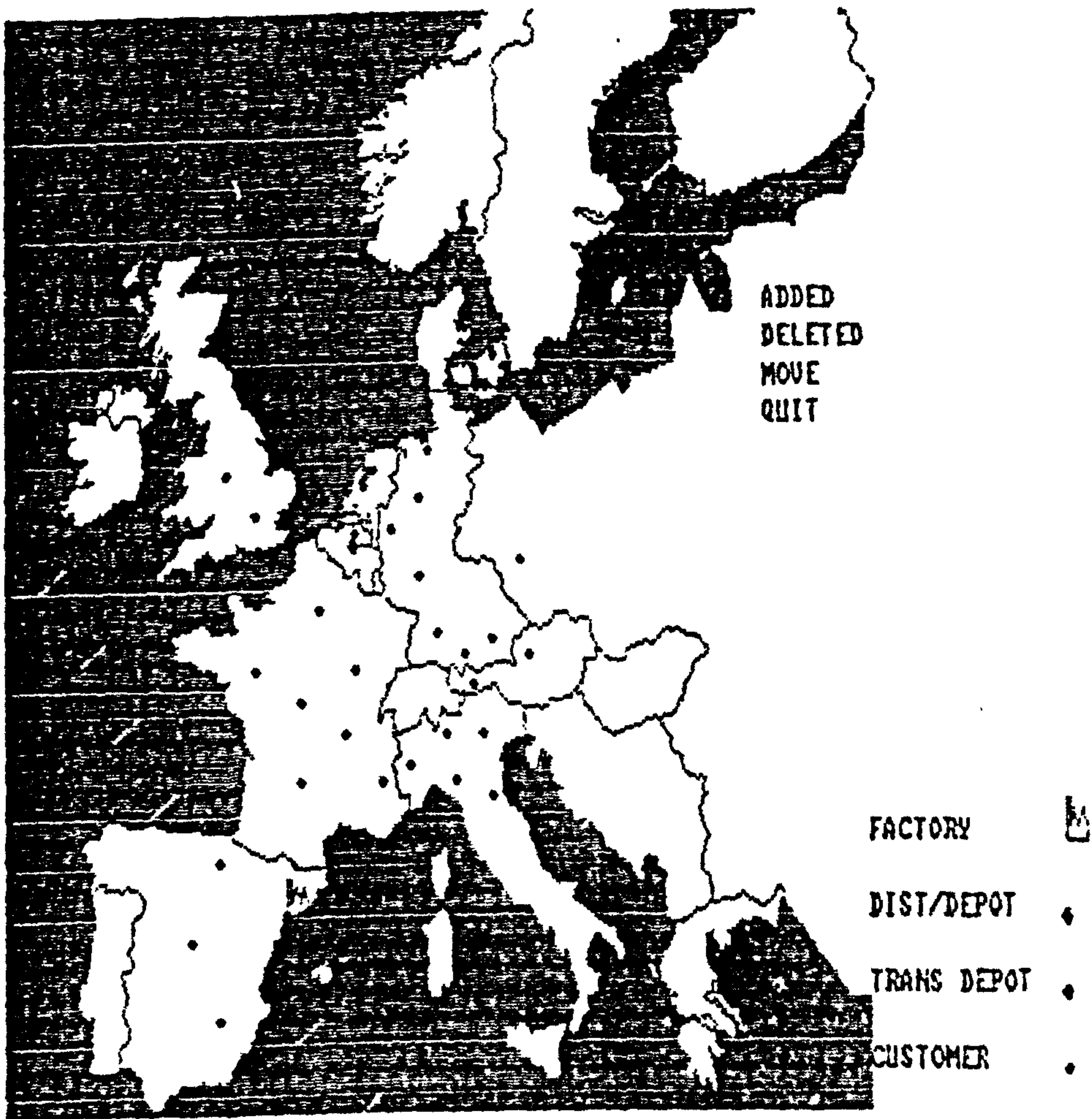

Figure U5.

CONTINUE

QUIT

CONTINUE to highlight another factory or the previous factory again.

QUIT to proceed to the next instruction.

MOVE:

The **MOVE** command is used to move a factory from one place to any other place on the **MAP**. Indicate the factory to be moved by using the cursor and the arrow keys. If the factory is not highlighted properly then the screen will display the following message;

FACTORY NOT FOUND

CONTINUE

QUIT

CONTINUE to highlight another factory or the previous factory again.

QUIT to proceed to the next instruction.

If the factory is highlighted properly then move the cursor to the place where the factory to be moved.

QUIT

KEEP THE RECORD OF THIS FILE ?

If you don't wish to use this file again then use **NO**.

If you wish to use this file again then use **YES**.

The image of the screen is given in figure U6

ENTER THE NAME

The file name may be up to fifteen characters long and extension **FAC** will be added to the filename.(ie if you enter **PARIS** the file name will be **PARIS.FAC**).

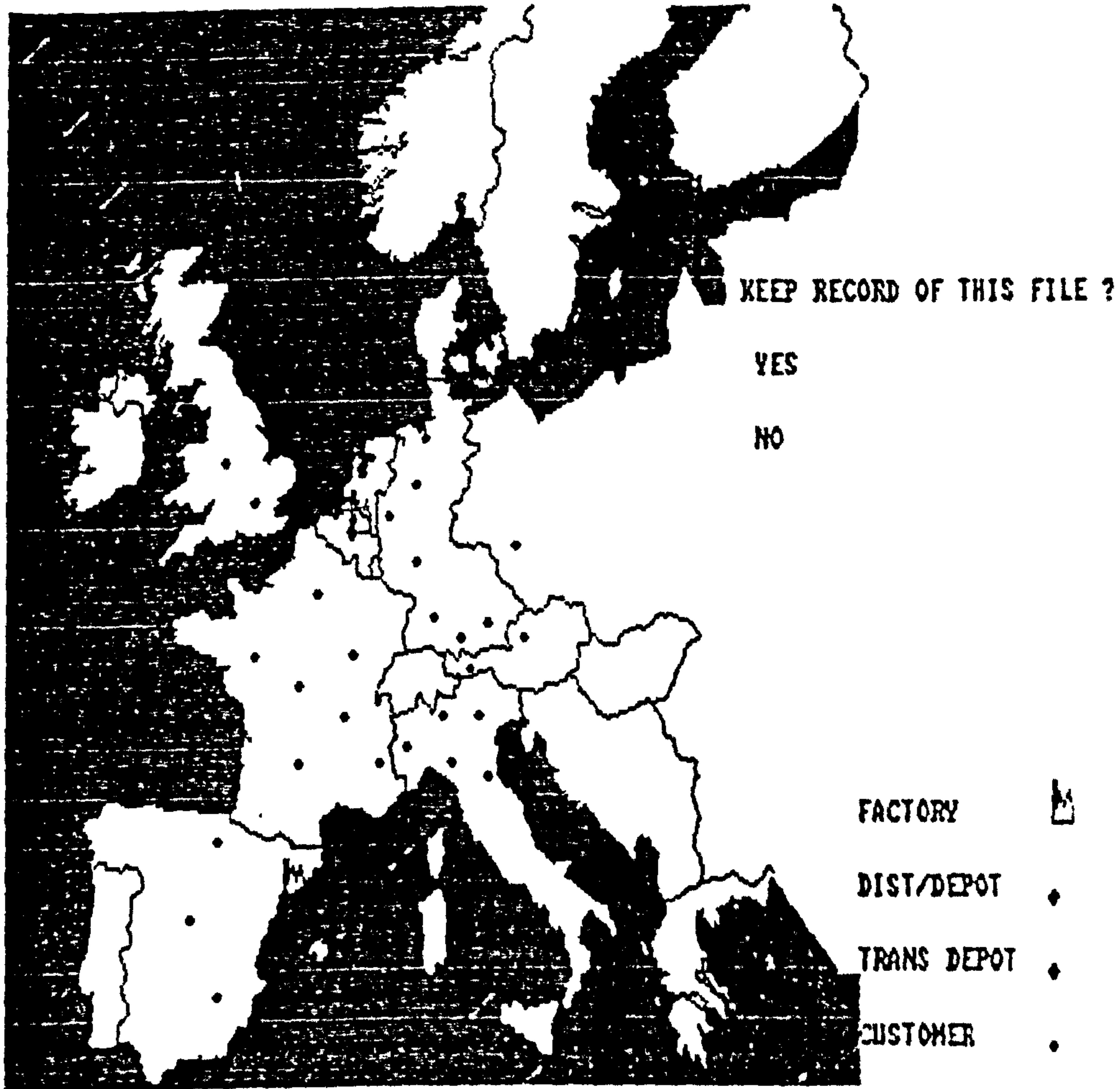

Figure U6.

U5.2 DEPOTS

ADD

DELETE

MOVE

QUIT

ADD:

The ADD is to add a depot to the system.

DIST/DEPOT

TRANS/DEPOT

If you wish to add a distribution depot to the system then enter 0 here. If you wish to add a transshipment depot then enter 1.

Indicate the depot location by using the cursor and arrow keys.

ENTER DEPOT NAME

The depot name may be up to 20 characters long.

(eg. LONDON).

ENTER THROUGHPUT CAPACITY

The minimum value for depot throughput is one thousand and the maximum is 5 million of the basic unit that is being utilised in modelling.

ENTER DIST/DEPOT FIXED COST

OR

ENTER TRANS/DEPOT FIXED COST

The fixed cost includes all other costs except the handling cost at the depot (ie 5000.00).

DELETE:

The DELETE is used to delete a depot from the system. Indicate the depot

to be deleted by using the cursor and arrow keys.

If a depot is not highlighted properly the following will appear on the screen.

DEPOT NOT FOUND

CONTINUE

QUIT

CONTINUE to highlight another depot or the previous depot again.

QUIT to proceed to next instructions.

MOVE:

The move command is used to move a depot from one place to any other place on the MAP using the cursor and arrow keys.

If the depot is not highlighted properly the screen will display the following message:

DEPOT NOT FOUND

CONTINUE

QUIT

CONTINUE to highlight another depot or the previous depot again.

QUIT to proceed to the next instruction.

If the depot is highlighted properly then move the cursor to the place where the depot to be moved.

QUIT

KEEP THE RECORD OF THIS FILE ?

If you don't wish to utilise this file again then use NO.

If you wish to use this file again then use YES.

ENTER THE NAME

The file name may be up to fifteen characters long and the extension DEP will be added to the filename (ie if you enter PARIS the file name will be PARIS.DEP).

U5.3 CUSTOMERS

ADD

DELETE

MOVE

QUIT

ADD:

The added command is used to add the customer to the system.

ENTER PRODUCT NUMBER

BETWEEN 1 AND 10

The customer product number must not be greater than the factory product number (ie there should be a factory to produce the goods to be delivered to customer).

ENTER CUS/DEMAND

ENTER REAL VALUE

This demand is the total demand in the period being modelled. (ie.120.00 units per period).

DELETE:

The DELETE is used to delete a customer from the system interactively.

If customer is not highlighted properly the following will appear on the screen.

CUSTOMER NOT FOUND

CONTINUE

QUIT

CONTINUE to highlight another customer or a previous customer again.

QUIT to proceed to the next instruction.

MOVE:

The **MOVE** command is used to move a customer from one place to any other place on the **MAP**.

If the customer is not highlighted properly the screen will display the following message:

CUSTOMER NOT FOUND

CONTINUE

QUIT

CONTINUE to highlight another customer or the previous customer again.

QUIT to proceed to the next instruction.

If the customer is highlighted properly move the cursor to the place where the customer to be moved.

QUIT

KEEP THE RECORD OF THIS FILE ?

If you don't wish to utilise this file again type **NO**.

If you wish to use this file again type **YES**.

ENTER THE NAME

The file name may be up to fifteen characters long and the extension **CUS** will be added to it (ie if you enter **PARIS** the filename will be **PARIS.CUS**).

U5.4 DEMAND

Demand Modified by
AREA
PRODUCTS
ALL CUSTOMERS
QUIT

The image for the screen is given in figure U7.

AREA

This function is used to increase the demand by area. The screen image is given in figure U8. All customers inside the rectangle will be effected.

Forecasting Factor

REAL VALUE

This factor is used to increase or decrease the demand of all the customer in a defined area.

For example:

If you wish to increase the demand by 20% then enter 1.20.

If you wish to reduce the demand by 20% then enter 0.80.

PRODUCTS

This function is used to increase the demand by product.

Forecasting Factor

REAL VALUE

This factor is used to increase or decrease the demand for each product.

For example:

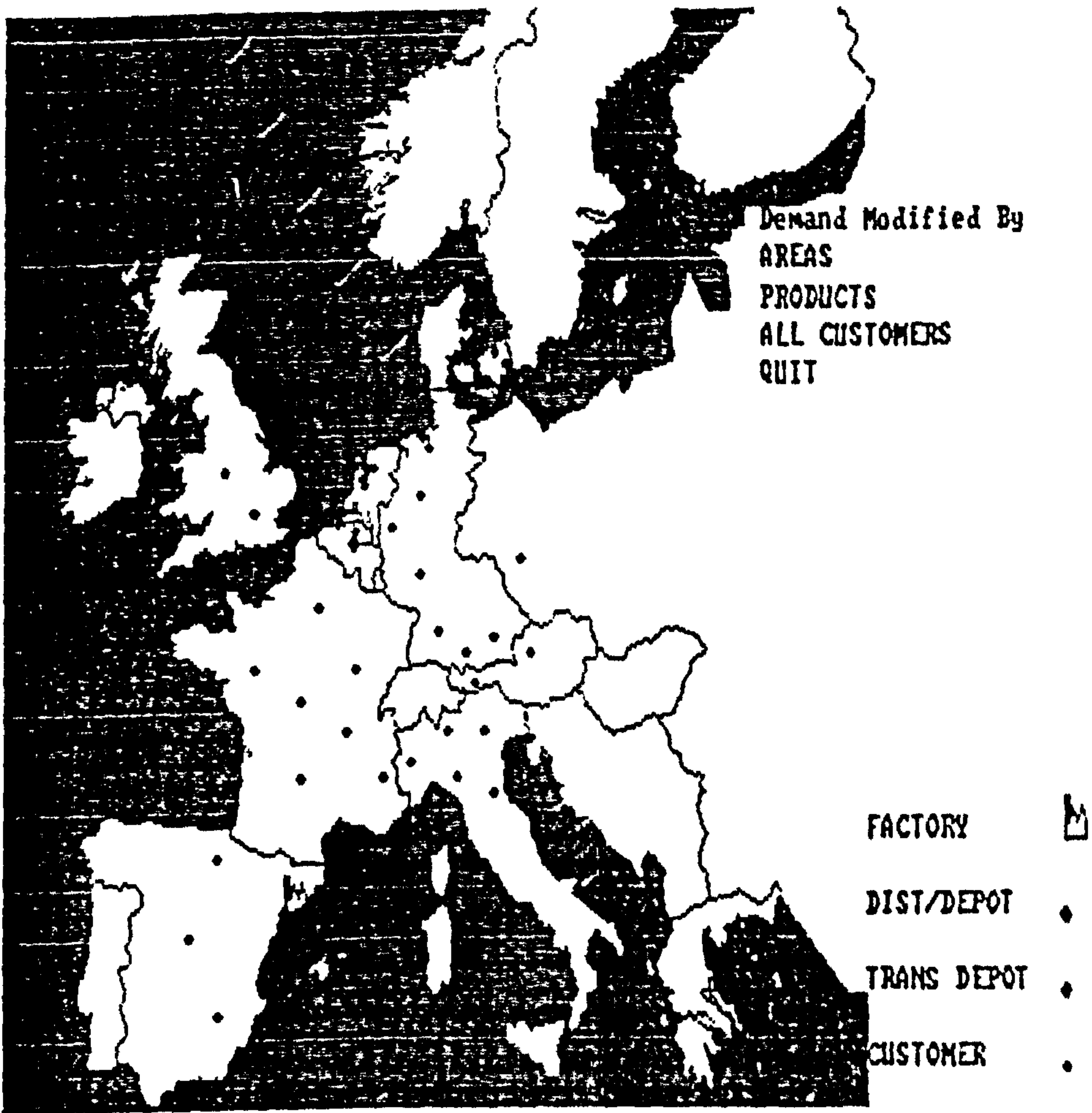

Figure U7.

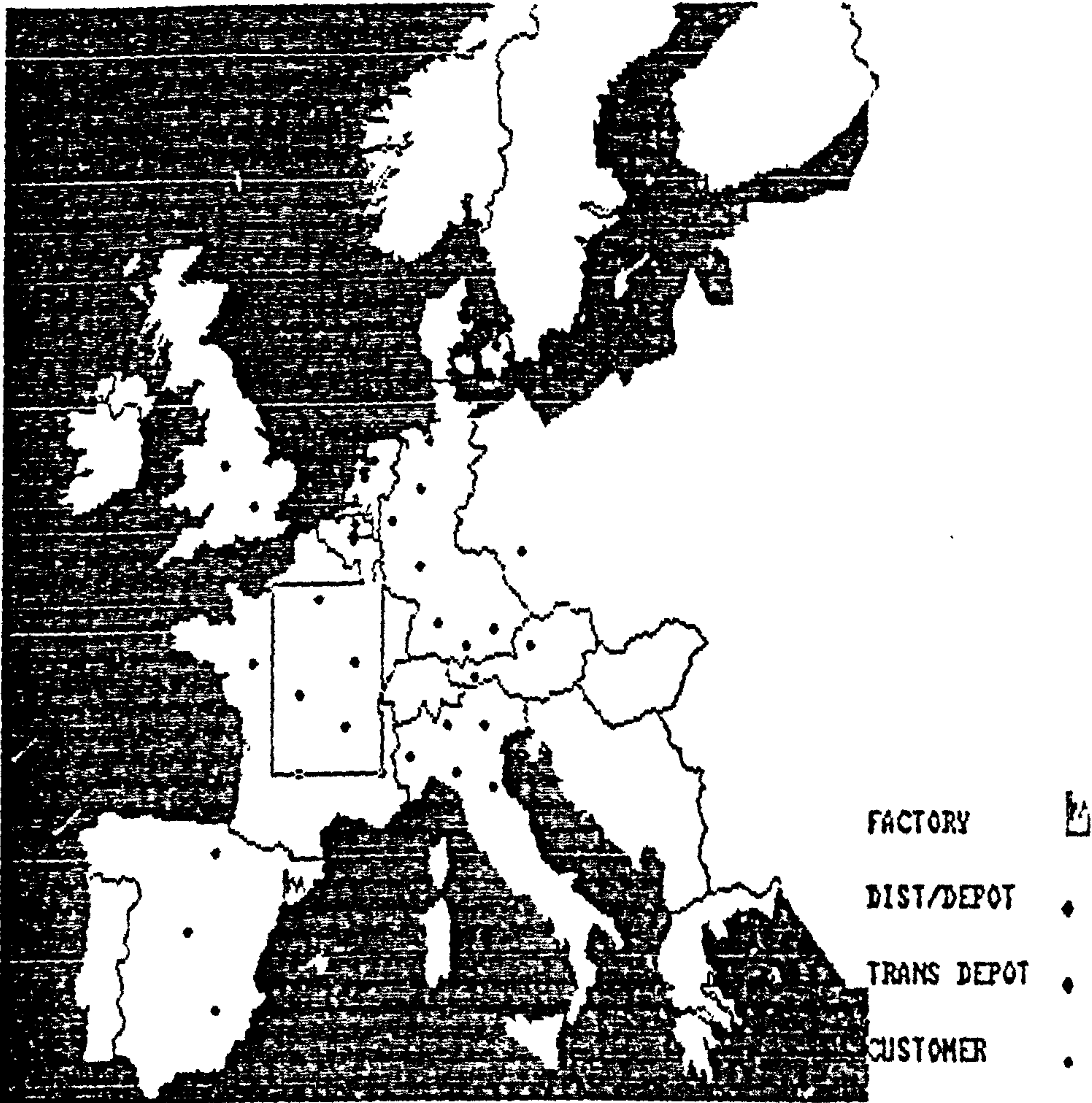

Figure U8.

If you wish to increase the demand by 20% then enter 1.20.

If you wish to reduce the demand by 20% then enter 0.80.

ALL CUSTOMERS

This function is used to increase the demand of all the customers.

Forecasting Factor

REAL VALUE

This factor is used to increase or decrease the demand of all the customers.

For example:

If you wish to increase the demand by 20% then enter 1.20.

If you wish to reduce the demand by 20% then enter 0.80.

QUIT

KEEP THE RECORD OF THIS FILE ?

If you don't wish to use this file again type NO.

If you wish to use this file again type YES.

ENTER THE NAME

The filename may be up to fifteen characters long and the extension CUS will be added to it (ie if you enter PEAK the file name will be PEAK.CUS).

U5.5 COST

Wiggle factor for local delivery:

(eg 1.20).

Rate per Kilometre for Local delivery:
(eg \$0.0025).

Local Delivery Vehicle capacity:
(eg 27.00 tonnes).

Average number of customers in a zone:
(eg 20.0).

Handling cost at distribution depot:
(eg \$4.00 per tonne).

Trucking cost relative to volume:
(eg \$0.050 per tonne).

Trucking cost relative to distance:
(eg \$0.0015 per tonne per kilometre).

Trucking Wiggle factor:
(eg 1.60).

Handling cost at transshipment depot:
(eg \$2.00 per tonne).

Local Trucking cost relative to volume:
(eg \$0.020 per tonne).

Local Trucking cost relative to distance:
(eg 0.001).

Motorway speed:
(eg 100.0 kilometre per hour).

Zone Speed:

(eg 60.0 kilometre per hour).

Unloading Time:

(eg 0.25 hours per drop).

Trip hours allowed:

(eg 10.00 hours).

Minimum zone time:

(eg 2.00 hours).

Extra days cost

(eg \$300.0 per day).

QUIT

KEEP THE RECORD OF THIS FILE ?

If you don't wish to use this file again type NO.

If you wish to use this file again type YES.

ENTER THE NAME

The filename may be up to fifteen characters long and the extension COS will be added to it (ie. if you enter TEST3 the file name will be TEST3.COS).

U6. MANUAL ALLOCATION

Allocation for

Customer

Transshipment depot

Distribution depot

QUIT

The image of the screen is depicted in figure U9.

U6.1 Customer

The image of the screen is given in figure U10.

For Depot to Customer Cost.

Move the cursor to the required customer, followed by carriage return. If the customer is not found, it will display the following message:

Customer not found

CONTINUE

QUIT

CONTINUE to highlight another customer or the previous customer again.

QUIT to proceed to the next instruction.

If cursor was correctly over a customer then it will display:

Depot

The screen image is given in figure U11. Move the cursor to the required depot, followed by carriage return. If depot was not found then the screen will display:

Depot not found.

CONTINUE

QUIT

CONTINUE to highlight another depot or the previous depot again;

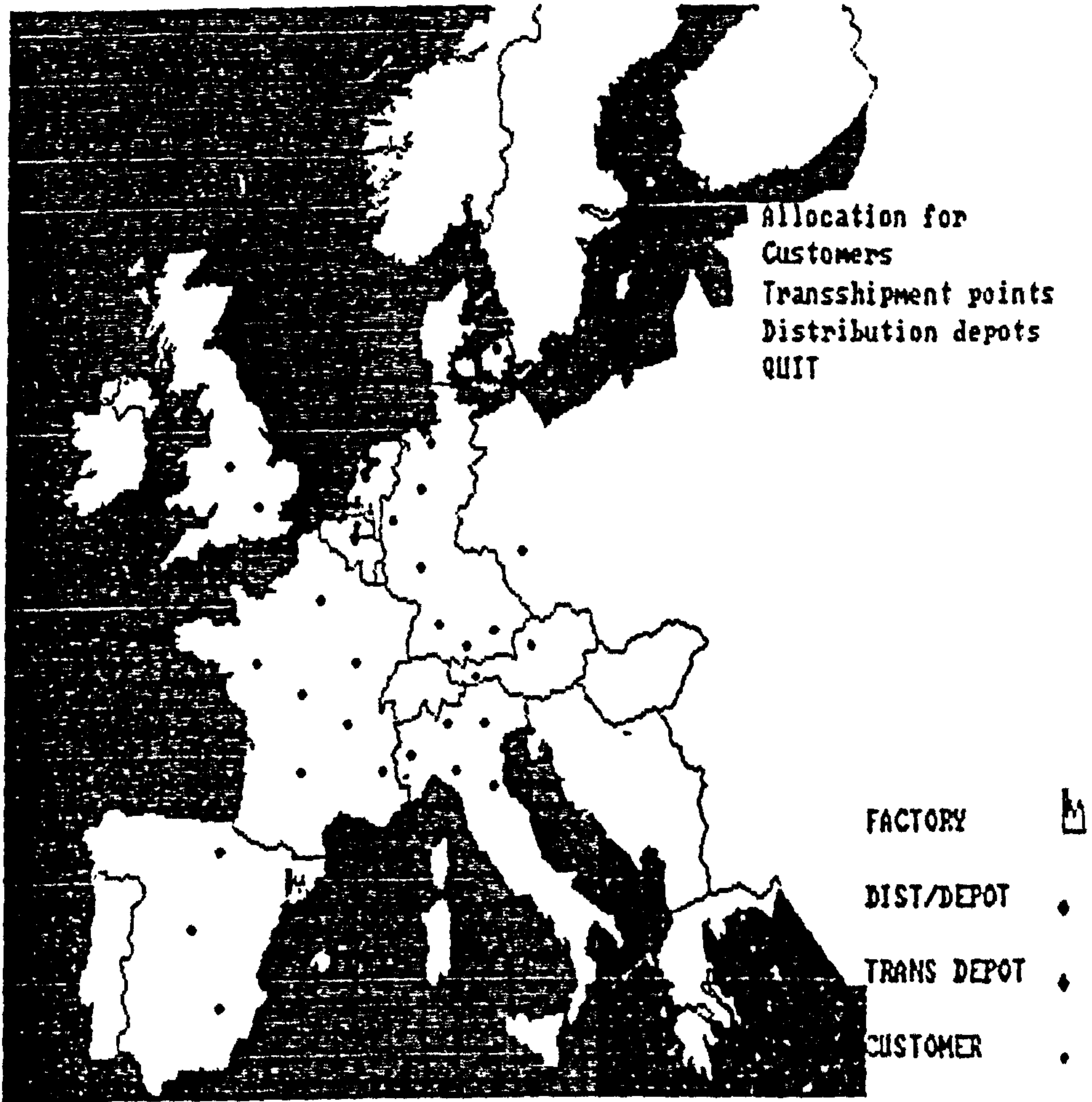

Figure U9.

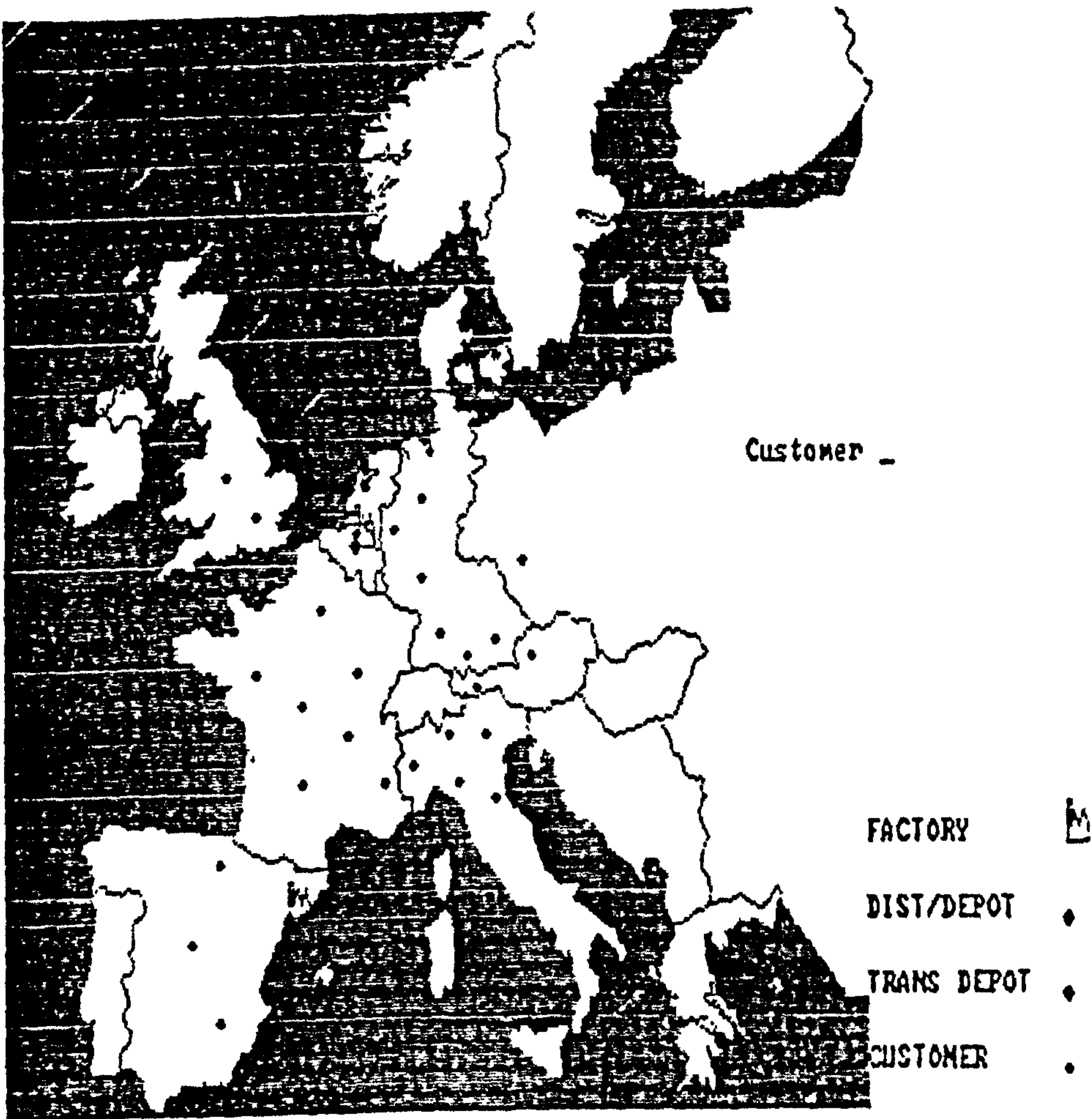

Figure U10.

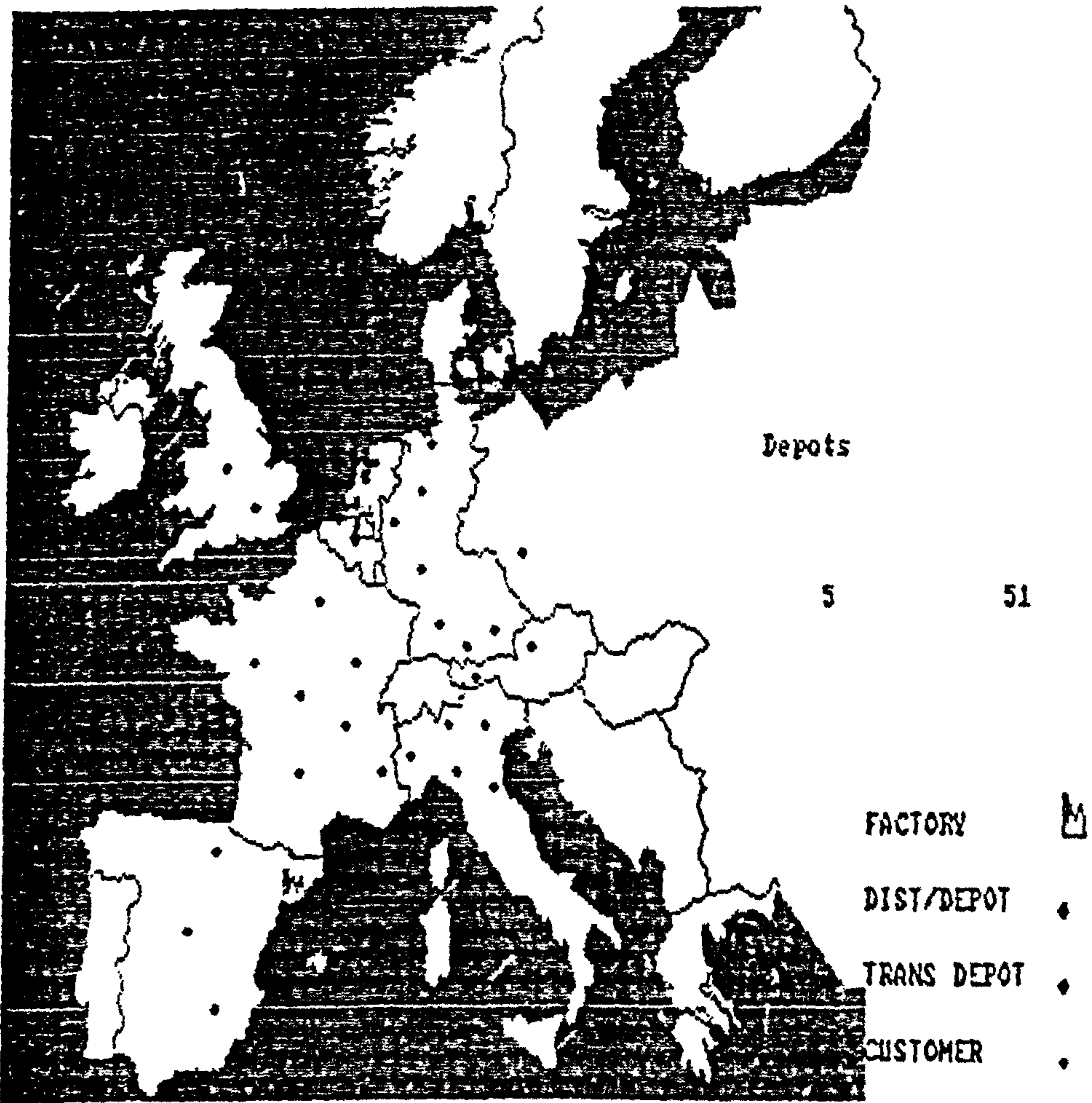

Figure U11.

QUIT to proceed to the next instruction.

If the depot was found, then the cost of the flow from depot to the customer is displayed. The screen image is given in figure U12.

U6.2 Transshipment Point

For depot to transshipment point cost:

Move the cursor to required transshipment point, followed by carriage return.

If the transshipment point is not found it will display:

Transshipment point not found

CONTINUE

QUIT

CONTINUE to highlight another transshipment point or the previous transshipment point again.

QUIT to proceed to the next instruction.

If the cursor was correctly over the transshipment point then it will display:

Depot

Move the cursor to the required Dist/depot followed by carriage return.

If the depot is not found the screen will display:

Depot not found.

CONTINUE

QUIT

CONTINUE to highlight another depot or the previous depot again;

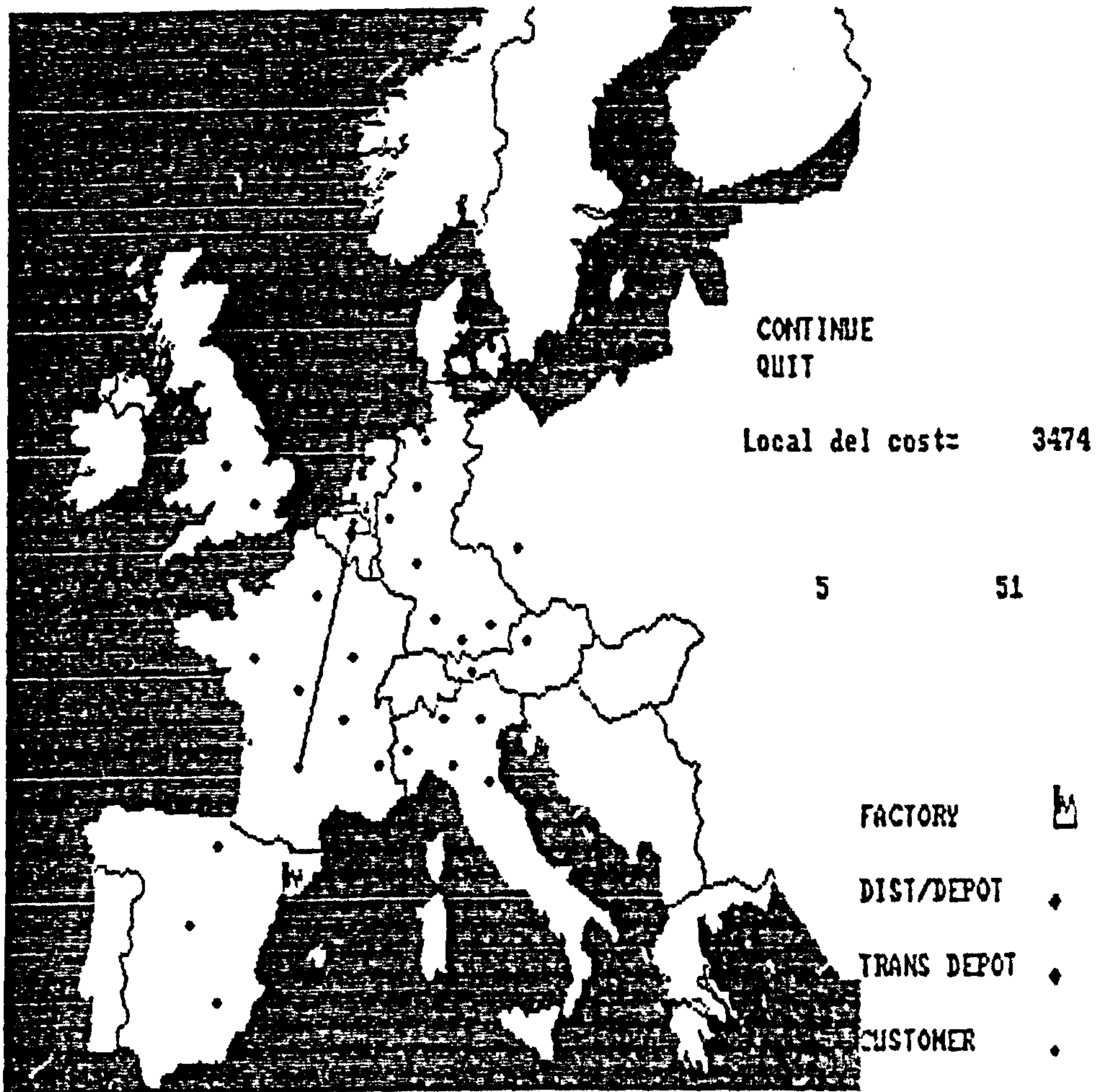

Figure U12.

QUIT to proceed to the next instructions.

If the depot is found then it will display the delivery cost.

U6.3 Depot

For Factory to depot costs:

Move the cursor to required Distribution Depot followed by carriage return.

If the Dist/Depot is not found, it will display:

Depot not found

CONTINUE

QUIT

CONTINUE to highlight another depot or the previous depot again;

QUIT to proceed to the next instruction.

If cursor was correctly over the depot then it will display:

Factory

Move the cursor to the required Factory, followed by carriage return.

If the Factory was not found then the screen will display:

Factory not found.

CONTINUE

QUIT

CONTINUE to highlight another factory or the previous factory again

QUIT to proceed to the next instruction.

If the factory is found then it will display the delivery cost.

U7. DISPLAY/PRINT DATA

This will display the report information on the screen.

DISPLAY FACTORY INFORMATION

DISPLAY DEPOTS INFORMATION

PRINT REPORT

QUIT

U7.1 DISPLAY FACTORY INFORMATION

PRODUCTION AT EACH FACTORY:

This displays the production at each factory.

DEPOT SERVED BY EACH FACTORY:

This shows which depot is served by which factory.

QUIT

This will return the system back to number 7.

U7.2 DISPLAY DEPOTS INFORMATION

THROUGHPUT INFORMATION

LOCAL DELIVERY COST

TOTAL COST FOR EACH DEPOT

CUSTOMER SERVED BY EACH DEPOT

QUIT

THROUGHPUT INFORMATION

This will display throughput for all depots.

LOCAL DELIVERY COST

Local delivery cost for each depot.

TOTAL COST FOR EACH DEPOT

Total running cost for each depot.

CUSTOMER SERVED BY EACH DEPOT

This shows the customers served by each depot.

QUIT

Proceed to the next instruction.

U7.3 PRINT REPORT

This command will print the most recent report on to a printer.

U7.4 QUIT

This command will take the system back to number 2.

U8. RESTART ALLOCATION

This restarts the allocation procedure again.

U9. ZOOM IN

This allows the user to display any part of the screen in detail, but it will not currently display the detailed map areas.

When this function being used a red colour window will appear on the

screen.

The Window may be moved around on the screen using arrow keys. It's size may be decreased by using (-) minus sign or it may increased by using (+) plus sign.

U10. PRINT SCREEN

WHICH PRINTER

COLOUR

EPSOM/IBM

The colour printer must currently be a Xerox 4020.