

Accepted Manuscript

The Effect of Residual Stresses Arising from Laser Shock Peening on Fatigue Crack Growth

A. Chahardehi, F.P. Brennan, A. Steuwer

PII: S0013-7944(10)00161-X
DOI: [10.1016/j.engfracmech.2010.03.033](https://doi.org/10.1016/j.engfracmech.2010.03.033)
Reference: EFM 3234

To appear in: *Engineering Fracture Mechanics*

Received Date: 15 December 2009
Revised Date: 13 March 2010
Accepted Date: 19 March 2010

Please cite this article as: Chahardehi, A., Brennan, F.P., Steuwer, A., The Effect of Residual Stresses Arising from Laser Shock Peening on Fatigue Crack Growth, *Engineering Fracture Mechanics* (2010), doi: [10.1016/j.engfracmech.2010.03.033](https://doi.org/10.1016/j.engfracmech.2010.03.033)

This is a PDF file of an unedited manuscript that has been accepted for publication. As a service to our customers we are providing this early version of the manuscript. The manuscript will undergo copyediting, typesetting, and review of the resulting proof before it is published in its final form. Please note that during the production process errors may be discovered which could affect the content, and all legal disclaimers that apply to the journal pertain.

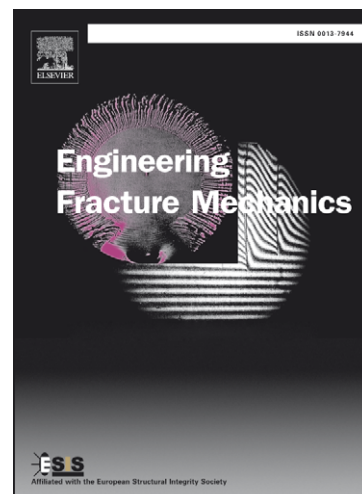

The Effect of Residual Stresses Arising from Laser Shock Peening on Fatigue Crack Growth

A. Chahardehi^a, F. P. Brennan^b and A. Steuwer^c

^a Corresponding author, Cranfield University, Cranfield, Beds, MK43 0AL, UK, a.chahardehi@cranfield.ac.uk, Tel. +44 (0) 1234 754631, Fax. +44 (0) 1234 758217

^b f.brennan@cranfield.ac.uk

^c ESS Scandinavia, Stora Algtan 4, 22350 Lund, Sweden and Nelson Mandela Metropolitan University, Gardham Avenue, Port Elizabeth, South Africa

ABSTRACT. Residual stresses have in the past been introduced to manipulate growth rates and shapes of cracks under cyclic loads. Previously, the effectiveness of shot peening in retarding the rate of fatigue crack growth was experimentally studied. It was shown that the compressive residual stresses arising from the shot peening process can affect the rate of crack growth. Laser Shock Peening can produce a deeper compressive stress field near the surface than shot peening. This advantage makes this technique desirable for the manipulation of crack growth rates. This paper describes an experimental program that was carried out to establish this effect in which steel specimens were partially laser peened and subsequently subjected to cyclic loading to grow fatigue cracks. The residual stress fields generated by the laser shock peening process were measured using the neutron diffraction technique. A state of compressive stress was found near the surface and tensile stresses were measured in the mid-thickness of the specimens. Growth rates of the cracks were observed to be more affected by the tensile core than by the compressive surface stresses.

KEYWORDS Fatigue Crack Growth; Laser Peening, Residual Stress, Neutron Diffraction

1 INTRODUCTION

The compressive residual stresses arising from surface treatment techniques such as shot and laser peening are currently assumed to retard fatigue crack growth and delay the initiation of fatigue cracks [1]. The rationale behind this is that the compressive 'beneficial' stress which is locked in the component will, when the component is loaded externally, superimpose on the applied stress. In case of a tensile applied stress, this superposition results in a total stress which is lower than the externally applied stress and therefore leads to lower stress intensity factors at the crack tip.

Laser shock peening is a surface treatment technique where a solid-state laser beam is pulsed upon a metallic surface, producing a planar shockwave that travels through the

material [2]. Here laser with a peak power greater than 1 GW is imaged to a spot size of about 5mm×5mm. Energy densities of 50 to 200 joules per cm^2 and pulse durations of 5 to 30 nanoseconds are typical [3]. As the laser beam irradiates the specimen, high pressure plasma from an ablative layer on the component is rapidly formed, sending a shock wave through the work piece which due to its high pressure travels some millimetres in the material and plastically deforms the material in its wake.

Compared to shot peening, laser peening generally has a much deeper effective penetration in the material, and compressive residual stresses can be generated much farther from the surface [4-6].

In the past, shot peening has been used to demonstrate this effect on the fatigue crack initiation and growth rate in steel [7] and aluminium specimens [5] under cyclic loading. As an example of the application of these findings, the effect of shot peening on crack shape control in fatigue specimens has also been studied [6]. The success of these experiments, along with the fact that laser shock peening generates compressive stress fields much deeper than those produced by shot peening, is an important factor in expecting even better fatigue resistant results from laser shock peening [5, 8].

In order to assess the influence of laser shock peening on fatigue crack growth rate and evaluate its advantage over shot peening, a set of experiments was set up which will be explained in the next section.

2 EXPERIMENTS

A set of experiments was carried out where a total of four steel plates were partially laser peened (hereby called specimens 1, 2, A and B), and fatigue cracks were grown through the peened area in two of them (specimens A and B). A starting notch was machined in these two specimens (A and B) and they were then precracked before being treated using laser beams. The residual stresses arising from the laser peening process were then measured using neutron diffraction strain measurement technique [9].

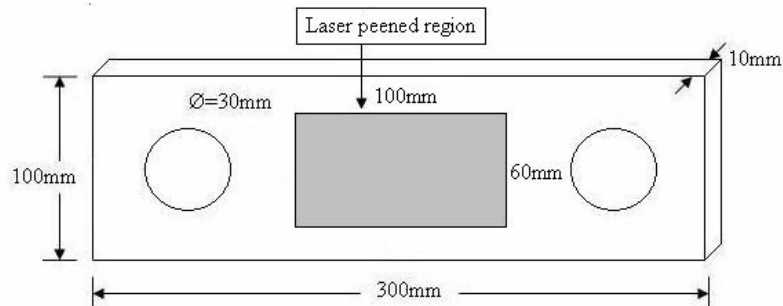

Figure 1- Specimens 1 and 2

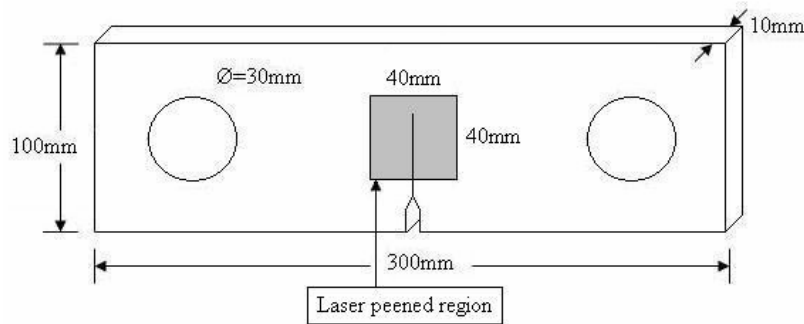

Figure 2- Specimens A and B

For the purpose of the current study, two types of specimens were examined. Figure 1 shows the specimens which were used to establish the likely relaxation of the residual stress by cyclic loading, and figure 2 shows the two notched and precracked specimens which were previously subjected to tensile fatigue loading and crack growth. The thickness of all the specimens used was 10mm, and they were made of BS EN 10025 Grade S275JR steel [10]. The accuracy of the measurements were determined at the experiment site as within 1% accuracy.

In order to establish the likely relaxation behaviour of the residual stress under the action of cyclic loads, specimen 1 was tested as unloaded (or virgin) and specimen 2 was previously subjected to several cycles of tensile loading between 5kN to 55kN (corresponding to 5MPa to 55MPa). This was the range that was used for the fatigue crack growth in specimen A. To obtain a through-thickness profile of residual stress in the laser peened region in specimens 1 and 2, a total number of eight measurement points were chosen symmetrical with respect to the mid-plane and lying on a line normal to the plane of the specimens at its geometrical centre and all three components of strain, namely normal (through thickness), longitudinal (along the longer dimension of the specimens) and lateral were taken. The coordinate of these points are shown in table 1.

Results of the measurements on specimens 1 and 2 show no detectable relaxation (or decrease) in the magnitude of these elastic strains, therefore it was concluded that in the scope of the current experiments, no relaxation effect should be considered.

| Point number | coordinates (mm) |
|--------------|------------------|
| 1 | (0,0,4.95) |
| 2 | (0,0,4) |
| 3 | (0,0,3) |
| 4 | (0,0,1) |
| 5 | (0,0,-1) |
| 6 | (0,0,-3) |
| 7 | (0,0,-4) |
| 8 | (0,0,-4.95) |

Table1 showing coordinated of the eight points measured in specimens 1 and 2

Transformation of the measured elastic strain components to stress components was achieved by means of the following equations which are derived when the generalised Hooke's law equations are solved for stress components:

$$\begin{aligned}
 \sigma_x &= \frac{\nu E}{(1+\nu)(1-2\nu)}(\varepsilon_x + \varepsilon_y + \varepsilon_z) + \frac{E}{(1+\nu)}\varepsilon_x \\
 \sigma_y &= \frac{\nu E}{(1+\nu)(1-2\nu)}(\varepsilon_x + \varepsilon_y + \varepsilon_z) + \frac{E}{(1+\nu)}\varepsilon_y \\
 \sigma_z &= \frac{\nu E}{(1+\nu)(1-2\nu)}(\varepsilon_x + \varepsilon_y + \varepsilon_z) + \frac{E}{(1+\nu)}\varepsilon_z
 \end{aligned} \tag{1}$$

A number of other locations were also examined to ensure uniformity of the residual stress field in the interior of the peened region. It was observed that the stress components in each direction were uniform in the peened region. However, to better understand the effect of laser peening in terms of the resulting residual stress field, the stress profiles on either sides of the boundary of the peened region were measured to establish any 'transitional' effects. Coordinates of these measurement points are shown in table 2; the 'peened' points were 2mm from the boundary and in the peened region, and 'unpeened' points were 2mm from the boundary outside the peened region. Again the z coordinate denotes the distance from the mid-plane.

| Point number | z-coordinate (mm) |
|--------------|-------------------|
| 1 | 4 |
| 2 | 3 |
| 3 | 2 |
| 4 | 1 |
| 5 | 0 |
| 6 | -1 |
| 7 | -2 |
| 8 | -3 |
| 9 | -4 |

Table2 showing coordinates for the points in specimen 1

The residual stress profiles through the thickness of specimens 1 and 2 in the peened region are shown in figures 3 and 4. In order to ensure the accuracy of the readings, strains at the required positions in each specimen was measured, and then the specimen was taken out of the set up and put back in, this time the reverse side facing the beam. Figures 3 and 4 show that a good agreement is observed between the two readings for each specimen.

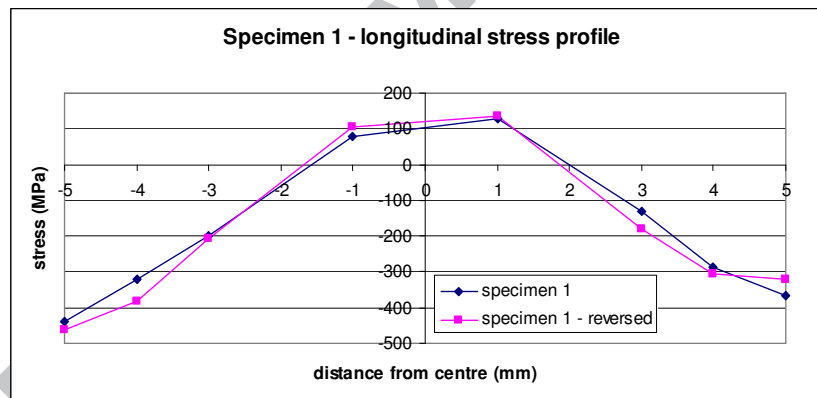

Figure 3- Residual stress distribution profile in specimen 1 at the centre of the laser peened region.

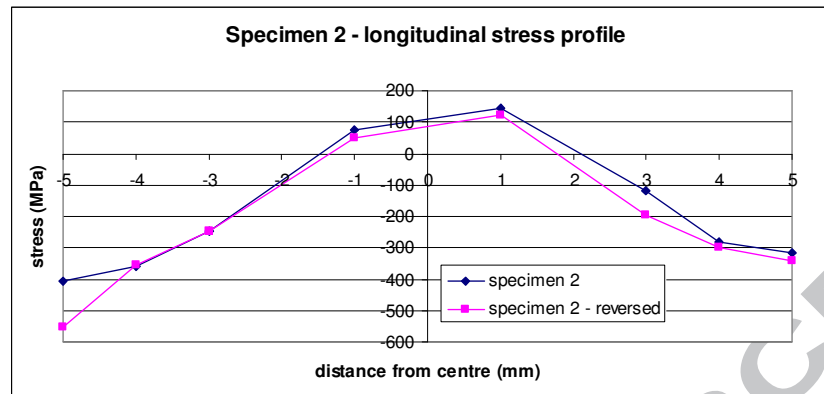

Figure 4- Residual stress distribution profile in specimen 2 at the centre of the laser peened region.

The effect of relaxation of the residual stresses under cyclic loads was also considered and experiments show that the relaxation of residual stresses arising from laser peening in the current test programme was negligible.

2.1 Fatigue Crack Growth Tests

Two different load levels were used in these experiments. Two identical specimens were tested in which fatigue cracks initiating from a notch were grown into a laser peened region under cyclic tensile loads. Details of the laser peened region are shown in figure 5.

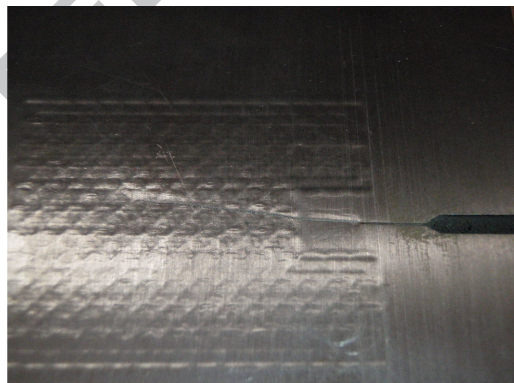

Figure 5- showing the notch as starter crack. The textured area has been treated with laser.

Two different load levels were used in these experiments. Specimen A was tested under cyclic tension between 5-55 kN and specimen B was tested under a cyclic tensile load of 5-95 kN. Given the cross section dimensions of these specimens as $10\text{mm} \times 100\text{mm}$, these loads respectively correspond to 5-55 MPa and 5-95 MPa of tensile stress. The crack length was measured using a travelling microscope.

2.2 Test Results

The a-N readings from the travelling microscope are shown in figures 6 and 7. The transition of the crack from the virgin material into the boundary of the peened region occurs at a crack length of 20mm.

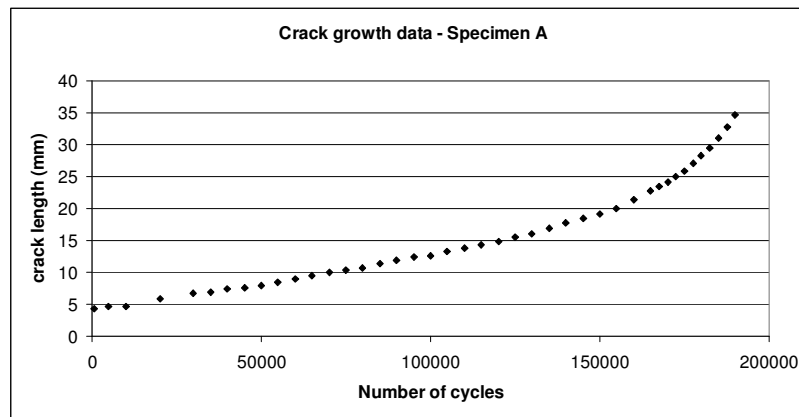

Figure 6- Fatigue crack growth data (a-N curve) for specimen A

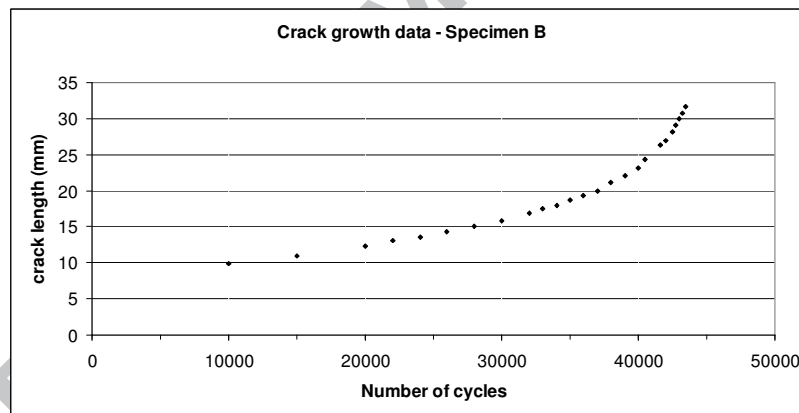

Figure 7- Fatigue crack growth data (a-N curve) for specimen B

3 ANALYSIS AND DISCUSSION

The results of the tests were not as expected. Based on the experience from shot peened specimens, a sudden halt in the growth of the crack was expected in the boundary of the treated region.

From the figures of stress distribution in the specimens (figures 3 and 4) it is evident that a tensile core of material exists in the midsection of the specimens. These tensile stresses may jeopardise the beneficial effect of the superficial, compressive stresses that

exist in the component. Both the stresses inside and outside of the peened region are used when calculating the stress intensity factor values using the weight function technique.

Weight functions [11,12] can be used to evaluate the stress intensity factor values for arbitrary stress distributions in cracked components. Due to the three dimensional nature of the problem, both the residual stresses and the stresses arising from the externally applied tensile force vary along the thickness of the specimen ahead of the crack tip. Kotousov and Wang [13] have used the assumption of a generalised plane-strain theory and derived the stress concentrations for specimens with V-shaped notches and a circular tip. Z Li and W Guo [14] have also expressed this three-dimensional stress field ahead of blunt V-notches using a series of finite element analyses. Both papers confirm the three dimensionality of the elastic stress field arising from the application of the external tensile load.

An important decision at this stage is how to incorporate the residual stress values obtained from the neutron diffraction test in a one-dimensional analysis. It may seem sensible that whereas a point by point superposition of the applied and residual stresses is pertinent for the case of a full three dimensional analysis, for a one dimensional crack dealing with the residual stress component used for each point along the crack front may be the average value of the longitudinal component of the residual stress averaged through the thickness. *One fundamental problem of the numerical superposition of stresses is that when the magnitude of the average compressive residual stress value is larger than the externally applied load, the model predicts no crack growth.* However, in reality both cracks did grow. If the total stress is taken as the superposition of the applied and the residual stress, negative values of total stress may be encountered. This suggests that if an averaged value of the residual stress is to be used for each section, then no Paris law coefficients can be used to predict the outcome of these tests. The crack growth in specimen A, despite the fact that the average compressive residual stress is -120MPa and the externally applied stress was 50MPa, signifies that the average compressive residual stress does not superimpose on the externally applied load. It should also be noted here that the experiment showed that the tensile stresses in the core section of the specimen ensured that the superficial compressive stresses present in the peened region did not cause the crack faces to contact during the fatigue testing, thus making the weight function approach valid. The fact that the crack grew indicates that K values are positive and non-zero. This will be discussed in detail in the next section.

To overcome this problem, the concept of 'effective fatigue stress' is introduced, which is the stress value that should be used for the evaluation of stress intensity factors in laser peened specimens when using one dimensional weight functions. This stress is here called the 'effective fatigue stress'.

In order to derive the effective fatigue stress, the following methodology is proposed.

From the $\frac{da}{dN}$ values, experimental SIFs can be evaluated. These values depend on the coefficients obtained from the CT test. Now, to find out what stress distribution gives the resulted K_{exp} , one can write:

$$K = \int_0^a \sigma f(x, a) dx \quad (2)$$

Where f is the weight function and is known for each crack length for the current specimen geometry.

For the n discrete points of crack length measurement

$$a = [a_1, a_2, \dots, a_n] \quad (3)$$

K_{exp} can be calculated as $K_{\text{exp}_i} = \sqrt{\frac{1}{C} \times \left(\frac{da}{dN}\right)_i}$. Now, by assuming $\sigma = \sigma_{\text{tensile}}$ for

$a = 0$ to $a = a_1$,

$$K_{\text{exp}_1} = \int_0^{a_1} \sigma_{\text{tensile}} f(x, a_1) dx \quad (4)$$

and

$$K_{\text{exp}_2} = \int_0^{a_1} \sigma_{\text{tensile}} f(x, a_2) dx + \int_{a_1}^{a_2} \sigma_{12} f(x, a_2) dx \quad (5)$$

Where σ_{12} denotes the stress acting on the section from $a = a_1$ to $a = a_2$. Similarly,

$$K_{\text{exp}_3} = \int_0^{a_1} \sigma_{\text{tensile}} f(x, a_3) dx + \int_{a_1}^{a_2} \sigma_{12} f(x, a_3) dx + \int_{a_2}^{a_3} \sigma_{23} f(x, a_3) dx \quad (6)$$

From these equations, the stress values can be evaluated as:

$$\sigma_{\text{tensile}} = \frac{K_{\text{exp}_1}}{\int_0^{a_1} f(x, a_1) dx} \quad (7)$$

$$\sigma_{12} = \frac{K_{\text{exp}_2} - \int_0^{a_1} \sigma_{\text{tensile}} f(x, a_2) dx}{\int_{a_1}^{a_2} f(x, a_2) dx} \quad (8)$$

$$\sigma_{23} = \frac{K_{\text{exp}_3} - \int_0^{a_1} \sigma_{\text{tensile}} f(x, a_3) dx - \int_{a_1}^{a_2} \sigma_{12} f(x, a_3) dx}{\int_{a_2}^{a_3} f(x, a_3) dx} \quad (9)$$

And by induction:

$$\sigma_{i-1,i} = \frac{K_{\text{exp}_i} - \int_0^{a_1} \sigma_{\text{tensile}} f(x, a_i) dx - \sum_{k=1}^{i-3} \left[\int_{a_k}^{a_{k+1}} \sigma_{k,k+1} f(x, a_i) dx \right]}{\int_{a_{i-1}}^{a_i} f(x, a_i) dx} \quad (10)$$

Where $f(x, a_i)$ is the weight function for a crack length of a_i .

Figure 8 shows the values of the effective fatigue stresses as obtained from the proposed technique. These values have been obtained by using the Paris law coefficients of $C = 6 \times 10^{-13}$ and $m = 4$ from the CT tests.

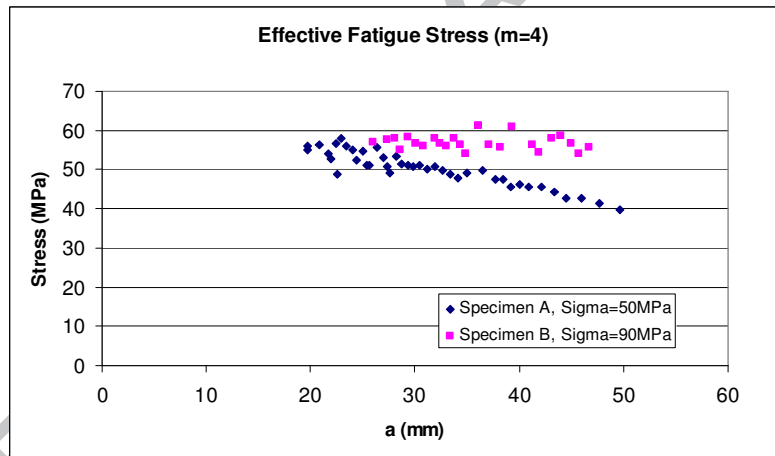

Figure 8- Effective fatigue stress distribution for specimens A and B ($m=4.00$). Here ‘Sigma’ denotes the applied stress range.

Here crack length ‘a’ is chosen such that the transition from the virgin material into the peened region occurs at $a=30\text{mm}$.

4 CONCLUSIONS

The effect of laser shock peening on fatigue crack growth in steel specimens was studied. Specimens were partially laser peened and were then subjected to cyclic fatigue loading in order to grow fatigue cracks. Due to the high levels of compressive residual stresses at the surface of the specimen, and analogous to the effect of shot

peening on crack growth, it was expected that the cracks should show considerable retardation upon reaching the treated region.

However, crack length vs. number of load cycle measurements did not show any considerable retardation of the fatigue cracks. This is believed to be due to the tensile core in the material that arises as a by-product of laser shock peening. This tensile region is essential for the internal balance of forces in the unloaded component.

The concept of effective fatigue stress was introduced and its evaluation was proposed. From the analysis of the test results it is evident that when dealing with laser shock peened specimens, traditional superposition of applied and residual stresses may lead to erroneous predictions, and a more rigorous, three dimensional analysis may always be required..

Acknowledgement

The authors would like to express their gratitude to Rutherford Appleton Laboratory, Harwell for the opportunity to use EnginX facility at ISIS for neutron diffraction residual stress measurement.

REFERENCES

1. H Berns and L Weber (1984), Influence of Residual Stresses on Crack Growth, in Impact Surface Treatment, Edited by S A Meguid, Elsevier, pp. 33-44.
2. M R Hill, A T DeWald, A G Demma, L A Hackel, H L Chen, C B Dane, R C Specht, F B Harris (Aug 2003) Laser Peening Technology, *Advanced Materials and Processes*, Vol. 161, No. 8.
3. L A Hackel and H L Chen (Sept 2003), Laser Peenig – A Processing Tool to Strengthen Metals or Alloys to Improve Fatigue Lifetime and Retard Stress-Induced Corrosion Cracking, *Laser Science and Technology*.
4. R A Everett, W T Matthews, R Prabhakaran, J C Newman Jr., M J Dubberly (Dec 2001), The Effect of Shot and Laser Peening on Fatigue and Crack Growth in 2024 Aluminum Alloy and 4340 Steel, Langley Research Center Report, NASA /TM-2001-210843.
5. O Hatamleh, J Lyons and R Forman (Mar 2007), Laser and shot peening effect on fatigue crack growth in friction stir welded 7075-T7351 aluminium alloy joints, *International Journal of Fatigue*, Vol. 29 Issue 3, pp 421-434.

6. S Ngiam, F P Brennan and C W Lee (Feb-Mar 2008), An experimental and analytical study of fatigue crack shape control by cold working, *Engineering Fracture Mechanics*, Vol. 75, Issues 3-4, pp. 355-365.
7. G H Farrahi, J L Lebrun and D Courtain (1995), Effect of Shot Peening on Residual Stress and Fatigue Life of a Spring Steel, *Fatigue and Fracture of Engineering Materials and Structures*, Vol. 18, No. 2, pp. 211-220.
8. Laser Shock Processing Increases the Fatigue Life of Metal Parts, *Materials and Processing*, Elsevier Science Publishing Co (Sept 1991).
9. T M Holden and G Roy (1996), The Application of Neutron Diffraction to the Measurement of Residual Stress and Strain, in Handbook of Measurement of Residual Stresses, Society for Experimental Mechanics, Edited by J Lu (1996), ISBN 08173229X.
10. British Standards Institute, "BS EN 10025:2004 – Hot Rolled Products of Non Alloy Structural Steels", British Standards Institute, 2004.
11. X R Wu (1990), Closed form weight function for edge crack problems, *Acta Mechanica Sinica*, Vol. 6, No. 2.
12. F P Brennan (1994), Evaluation of stress intensity factors by multiple reference state weight function approach, *Theoretical and Applied Fracture Mechanics*, Vol. 20, pp. 249-256.
13. A Kotousov and C H Wang, Three-dimensional stress constraint in an elastic plate with a notch, *International Journal of Solids and Structures*, Vol. 39 pp. 4311-4326 (2002).
14. Zhenhuan Li and Wanlin Guo, Three-dimensional elastic stress fields ahead of blunt V-notches in finite thickness plates, *International Journal of Fracture*, Vol. 107, pp. 53-71 (2001).