



Debris Removal from Low Earth Orbit  
DR LEO

Summary of the Group Design Project  
MSc in Astronautics and Space Engineering 2009/10  
Cranfield University

College of Aeronautics Report 1001

ISBN 978-1-907413-04-9

Dr. Stephen Hobbs  
Cranfield Space Research Centre  
School of Engineering  
Cranfield University  
Cranfield  
Bedford MK43 0AL UK  
s.e.hobbs@cranfield.ac.uk

13 September 2010



## **Abstract**

Students of the MSc course in Astronautics and Space Engineering 2009/10 at Cranfield University studied a low Earth orbit (LEO) debris removal mission for their group project. The mission's name was DR LEO (Debris Removal from LEO) and its aim was to develop a credible mission baseline using conventional technology to perform active debris removal from LEO. This report summarises the students' work and their findings.

The report consists of an overview and discussion of the technical work of the project and a compilation of the executive summaries which describe the specific contributions of each student.

The baseline mission design developed is broadly credible and provides a useful benchmark against which other missions can be compared to evaluate the potential of alternative technologies. The mission costing from this first design iteration sets a benchmark cost per unit mass de-orbited of approximately € 20–30k kg<sup>-1</sup> using conventional chemical propulsion.

ISBN 978-1-907413-04-9

This report is available electronically from Cranfield University's CERES service (<https://dspace.lib.cranfield.ac.uk/>).

Copyright Cranfield University 2010. All rights reserved. No part of this publication may be reproduced without the written permission of the copyright holder.

## Acknowledgements

The project is very much a team effort, and contributions from all those involved are much appreciated.

First of all, the work presented is primarily that of the MSc students (Ruben Amengual, Francois Caullier, James Cole, Michael Demel, Rushi Ghadawala, Vinay Grama, Guillaume Mathon-Marguerite, Lolan Naicker, Samuel Pin, Sandrine Quevieux, and Andrew Ratcliffe), who have each contributed about 600 hours.

Other members of staff in Cranfield's Space Research Centre and contacts in the space industry have often helped students by responding to queries or providing technical information. The time spent, help provided, and general encouragement is greatly appreciated.



# Contents

<b>Contents</b>	<b>iii</b>
<b>List of figures</b>	<b>v</b>
<b>List of tables</b>	<b>vii</b>
<b>1 Introduction</b>	<b>1</b>
1.1 MSc Group Project . . . . .	1
1.1.1 Organisation of the Project . . . . .	1
1.1.2 The DR LEO mission . . . . .	1
1.2 Organisation of this report . . . . .	2
<b>2 Technical Discussion</b>	<b>5</b>
2.1 System . . . . .	5
2.1.1 Requirements and Constraints . . . . .	5
2.1.2 Baseline Selection . . . . .	6
2.2 Mission . . . . .	6
2.2.1 Requirements Analysis: Mission . . . . .	7
2.3 Mechanical . . . . .	8
2.4 Electrical . . . . .	8
2.5 Payload . . . . .	9
2.5.1 Target Selection . . . . .	9
2.5.2 Requirements Analysis: Grappling and Docking . . . . .	9
2.5.3 Technology demonstration payloads . . . . .	10
<b>3 Discussion and Conclusions</b>	<b>13</b>
3.1 Discussion . . . . .	13
3.1.1 Budgets . . . . .	13
3.1.2 Baseline . . . . .	13
3.2 Conclusions . . . . .	14
3.3 Future Work . . . . .	14
<b>References</b>	<b>18</b>
<b>A Optimization of the Parking Orbit</b>	<b>19</b>
<b>B Mission Baseline Technical Summary</b>	<b>23</b>
B.1 Mission objectives . . . . .	23
B.1.1 Mission statement . . . . .	23
B.1.2 Requirements . . . . .	23
B.1.3 Constraints . . . . .	24
B.2 Baseline . . . . .	24
B.3 Configuration . . . . .	25
B.4 Mission Timeline . . . . .	25
B.5 System Budgets . . . . .	26

B.5.1	Budgets incl. technology demonstrations . . . . .	26
B.5.2	Alternative configuration budgets . . . . .	27
B.5.3	Delta-V budget . . . . .	28
B.5.4	Communication link budget . . . . .	28
B.5.5	Data budget . . . . .	28
<b>C</b>	<b>Individual Report Executive Summaries</b>	<b>33</b>
C.1	Executive Summary: DR LEO, Requirements, budgets, EPS, Ruben Amengual . .	34
C.1.1	Requirements and constraints . . . . .	34
C.1.2	Budgets . . . . .	34
C.1.3	Electrical Power System (EPS) . . . . .	35
C.1.4	Discussion and conclusion . . . . .	36
C.2	Executive summary: DR.LEO, AOCS and Rendezvous, François Caullier . . . . .	37
C.2.1	AOCS . . . . .	37
C.2.2	Rendezvous . . . . .	38
C.3	Executive summary: DR.LEO, Payload, James Cole . . . . .	40
C.3.1	Target Selection . . . . .	40
C.3.2	Payload User Requirements . . . . .	40
C.3.3	Electrodynamic Tether . . . . .	40
C.3.4	Low Thrust Propulsion . . . . .	41
C.3.5	Conclusion . . . . .	41
C.4	Executive summary: DR.LEO, Baseline, Operations, and Software, Michael Demel	42
C.4.1	Baseline Design and Target Selection Methodology . . . . .	42
C.4.2	Operations . . . . .	43
C.4.3	Software Architecture and OBDH . . . . .	43
C.5	Executive summary: DR.LEO, Budgets, Rushi Ghadawala . . . . .	46
C.5.1	Delta-V budget for mission baseline concepts . . . . .	46
C.5.2	Trade-off studies for Mission concepts . . . . .	46
C.5.3	Antenna Specifications . . . . .	46
C.5.4	Link Budget Analysis . . . . .	46
C.6	Executive summary: DR.LEO, Mechanisms, Vinay Grama . . . . .	48
C.6.1	Docking mechanism . . . . .	48
C.6.2	Launch adapter . . . . .	50
C.6.3	Solar array deployment mechanism . . . . .	50
C.6.4	Antenna deployment mechanism . . . . .	50
C.6.5	Conclusion . . . . .	51
C.7	Executive Summary: DR.LEO, Launch and propulsion, Guillaume Mathon-Margueritte	52
C.7.1	Launch . . . . .	52
C.7.2	Propulsion . . . . .	53
C.8	Executive summary: DR.LEO, Lolan Naicker . . . . .	55
C.8.1	Background . . . . .	55
C.8.2	Overview . . . . .	55
C.8.3	Analysis . . . . .	56
C.9	Executive Summary: DR.LEO: Robotic Arm Design, Samuel PIN . . . . .	58
C.9.1	First shaping . . . . .	58
C.9.2	Sizing iterations . . . . .	59
C.9.3	Mechanisms selection . . . . .	59
C.9.4	Conclusion . . . . .	60
C.10	Executive Summary: DR.LEO, Structure, Sandrine Quevreux . . . . .	62
C.10.1	Initial sizing . . . . .	62
C.10.2	Detailed sizing . . . . .	62
C.10.3	Conclusion . . . . .	64
C.10.4	Key references . . . . .	64
C.11	Executive summary: DR.LEO, Configuration, Andrew Ratcliffe . . . . .	65



# List of Figures

1.1	DR LEO team photograph . . . . .	2
1.2	Work breakdown structure for the LEO Debris Removal project DR LEO. . . . .	3
1.3	Summary of the baseline concept for DR LEO . . . . .	4
2.1	Difference in RAAN precession rate between parking and target orbits . . . . .	8
2.2	Model for the docked target and de-orbit spacecraft to estimate mass properties . .	12
3.1	Alternative DR LEO mission architecture . . . . .	14
A.1	Overview of the active debris removal concept . . . . .	21
A.2	Mass margin for 5 targets . . . . .	21
A.3	Mass margin for 7 targets . . . . .	22
B.1	Summary of the baseline concept for DR LEO . . . . .	24
B.2	The five DR LEO spacecraft stacked for launch in the Soyuz fairing . . . . .	25
B.3	Top and bottom views of the DR LEO spacecraft (dimensions in mm). . . . .	26
B.4	Side and bottom views of the DR LEO spacecraft (dimensions in mm). . . . .	26
B.5	General configuration for the DR LEO spacecraft. . . . .	27
C.1	Thrusters positions . . . . .	37
C.2	Rendezvous trajectories . . . . .	38
C.3	Original Baseline Design . . . . .	42
C.4	YUKI chaser spacecraft (sketch by Grama, 2010) . . . . .	43
C.5	YUKI chaser spacecraft (CAD drawing by Ratcliffe, 2010) . . . . .	43
C.6	DR LEO mission phases . . . . .	44
C.7	YUKI State Transition Diagram . . . . .	44
C.8	Nozzle insert (dimensions in mm) . . . . .	48
C.9	Linear deployment device with nozzle insert . . . . .	49
C.10	Version 1 docking ring . . . . .	49
C.11	Version 2 docking ring . . . . .	50
C.12	MILA and ISA . . . . .	50
C.13	Propulsion system . . . . .	54
C.14	Overview of the orbits used . . . . .	55
C.15	Chemical Transfer : Finite burns centred at apogee and perigee . . . . .	56
C.16	Electric Transfer : Radial position over time . . . . .	57
C.17	Arm deployment. . . . .	58
C.18	Arm kinematic diagram. . . . .	58
C.19	Arm face view and main dimensions . . . . .	59
C.20	Damping torques - third calculation . . . . .	60
C.21	ADAMS torque results . . . . .	60
C.22	The SRA (left) and the ECD (right) . . . . .	61
C.23	Primary structure + solar panel + tanks - Patran model and normal modes . . . .	63
C.24	Standard Chaser Spacecraft . . . . .	65
C.25	Launch configurations of the chaser spacecraft . . . . .	66
C.26	Bi-propellant engine configuration . . . . .	67

# List of Tables

1.1	DR LEO work package breakdown and allocation. The references are to the students' individual reports documenting their technical contributions. . . . .	3
2.1	Estimated lifetimes for various orbit heights . . . . .	7
2.2	$\Delta V$ required for orbit maintenance or to de-orbit . . . . .	8
2.3	Mass properties for the target, chaser, and docked spacecraft . . . . .	10
2.4	Formulas used to estimate moments of inertia for the target . . . . .	11
2.5	Estimated values of the moments of inertia for the Ariane IV upper stage . . . . .	11
A.1	Soyuz launcher capability from Kourou . . . . .	19
A.2	Assumed chaser spacecraft parameters . . . . .	20
A.3	ADR target debris orbit parameters . . . . .	20
B.1	DR LEO mission operations timelines for each of the five "Yuki" chaser spacecraft.	27
B.2	DR LEO mass budget . . . . .	28
B.3	Spacecraft cost including TFU and insurance . . . . .	28
B.4	DR LEO cost budget including technology demonstration payloads . . . . .	29
B.5	DR LEO power budget for the parking orbit phase. . . . .	29
B.6	DR LEO power budget for the capture /docking phase. . . . .	29
B.7	DR LEO power budget for the travelling or de-orbiting phases. . . . .	29
B.8	DR LEO mass budget . . . . .	30
B.9	Spacecraft cost including TFU and insurance . . . . .	30
B.10	DR LEO cost budget (excluding technology demonstration) . . . . .	30
B.11	DR LEO power budget for the parking orbit phase . . . . .	30
B.12	DR LEO power budget for the capture /docking phase . . . . .	31
B.13	DR LEO power budget for the travelling or de-orbiting phases. . . . .	31
B.14	Delta-V costs for each propulsion system . . . . .	31
B.15	Main antenna parameters . . . . .	31
B.16	Communication link parameters . . . . .	31
B.17	Main processor data budget . . . . .	32
B.18	AOCS processor data budget . . . . .	32
C.1	Sub-system responsibilities for each student . . . . .	33
C.2	DR LEO mass budget . . . . .	35
C.3	DR LEO cost budget. The mean cost per kg of debris de-orbited is € 39.0 k FY2010 including the cost of technology demonstration payloads. . . . .	35
C.4	DR LEO power budget for the capture /docking phase. . . . .	36
C.5	List of chosen LEO space debris targets . . . . .	40
C.6	DR LEO mission operations timelines for each of the five "Yuki" chaser spacecraft.	45
C.7	$\Delta V$ budget for each concept . . . . .	46
C.8	Mission concept trade-off . . . . .	46
C.9	Antenna Specifications . . . . .	46
C.10	Link budget summary . . . . .	47
C.11	Launch vehicle selection (Isakowitz, Hopkins and Hopkins, 2004) . . . . .	52
C.12	Propellant calculation and key results (based on Wertz and Larson, 1999) . . . . .	53
C.13	Initial sizing - results . . . . .	62

C.14 Cylinder - final selection . . . . .	63
C.15 Panels - final selection . . . . .	64



# Chapter 1

## Introduction

This report summarizes a group project (space debris removal from low Earth orbit) of the MSc in Astronautics and Space Engineering for the academic year 2009/10 at Cranfield University. This chapter introduces the project's purpose and management and the roles taken by individual students in the project. The rest of the report includes a technical summary and discussion of the project, and then the full set of executive summaries from the individual reports written by each student.

### 1.1 MSc Group Project

Each year, students of the MSc in Astronautics and Space Engineering are given a current topic in the space industry as the theme for their group project. Students work in teams of typically 8–16 students on the project, which runs from October to the end of March. One of the projects for the year 2009/10 was a debris removal mission for low Earth orbit (LEO); the project was named DR LEO (Debris Removal from LEO).

#### 1.1.1 Organisation of the Project

The project runs over the first two terms (October to Easter) of the year long MSc course in Astronautics and Space Engineering at Cranfield University. The students work as one team, organised into several subgroups, and each student contributes about 600 hours' effort to the project; the total resource represented by the project is approximately 6600 hours' work (or 4 man-years) for the academic year 2009/10.

Students are given responsibility for all technical aspects of the mission and over the 6 months of the project are required to develop a credible baseline mission. There are formal weekly progress meetings which staff supervisors attend, and two key milestones. The first is a System Requirements Review (SRR) presentation in early December and the second is the more formal Preliminary Design Review (PDR) in late March. The project runs in a similar manner to many industry projects and is intended to teach both technical and transferable skills to students.

Table 1.1 lists the students involved in the project and their technical responsibilities, Figure 1.1 shows all the student members of the DR LEO team, and Figure 1.2 shows the project work breakdown structure and the main work packages allocated.

The whole team met weekly to share progress and make key decisions about the mission design. Students in each of the sub-groups also met between the main meetings as they worked on their individual responsibilities - with the system engineers working hard to coordinate all the separate tasks.

#### 1.1.2 The DR LEO mission

The summarized requirements which the team worked to were to de-orbit 5 Ariane IV upper stages from an orbit height around 800 km (and all with an orbit plane inclination near  $98^\circ$ ).

The main steps in the mission design were:



Figure 1.1: The DR LEO team members (from left to right): (front row) Rushi Ghadawala, Samuel Pin, Ruben Amengual, Vinay Grama, Andrew Ratcliffe, (second row) James Cole, Francois Caullier, Guillaume Mathon-Marguerite, Lolana Naicker, Sandrine Quevreux, Michael Demel

- Analyse requirements
- Propose concepts for the baseline mission
- Select the preferred baseline concept (using a simple trade-off)
- Develop a quantitative baseline design
- Review findings

The baseline mission concept which the team chose is summarised in Figure 1.3. This mission uses 5 identical spacecraft (with no “mother” spacecraft) launched together and then placed initially in a parking orbit above the targets but at approximately the same orbit inclination. The orbit plane precesses at a different rate to the targets’ orbits and so eventually the parking orbit aligns with each target in turn; as the orbits align one of the spacecraft changes orbit to rendezvous with its target and then to de-orbit it (with atmospheric re-entry over the South Pacific to minimise the risk of damage to terrestrial property).

## 1.2 Organisation of this report

Following this Introduction, Chapter 2 and Appendix B give an overview of the technical work performed by the students and summarise their findings (e.g. tables for the mass, power, cost and propulsion budgets). This chapter also serves as an overview of the constraints the design had to meet. Chapter 3 is a brief discussion of the the project’s findings with some suggestions for further work. The main content of the report is Appendix C where Executive Summaries from the students’ reports are presented.

This report is based on the reports written by students describing their individual project responsibilities. The full reports are available from the School of Engineering, Cranfield University, and are summarised in Appendix C. *Readers should note that although gross errors in the individual reports should have been corrected, minor inconsistencies may remain in the detailed technical work presented.*

Table 1.1: DR LEO work package breakdown and allocation. The references are to the students' individual reports documenting their technical contributions.

WP	Description	Student
WP1000 System	Requirements, Budgets	Ruben Amengual (Amengual, 2010)
	Risk, Baseline	Rushi Ghadawala (Ghadawala, 2010)
	Operations, S/ware	Michael Demel (Demel, 2010)
WP2000 Mission	Orbit	Lolan Naicker (Naicker, 2010)
	Launch, Propulsion	Guillaume Mathon-Marguerite (Mathon-Marguerite, 2010)
WP3000 Mechanical	AOCS	Francois Caullier (Caullier, 2010)
	Configuration, Thermal Structure	Andrew Ratcliffe (Ratcliffe, 2010)
	Mechanisms	Sandrine Quevreux (Quevreux, 2010)
WP4000 Electrical	Power	Ruben Amengual (Amengual, 2010)
	Data	Michael Demel (Demel, 2010)
WP5000 Payload	Communications	Rushi Ghadawala (Ghadawala, 2010)
	Requirements	James Cole (Cole, 2010)
	Robotic arm	Samuel Pin (Pin, 2010)

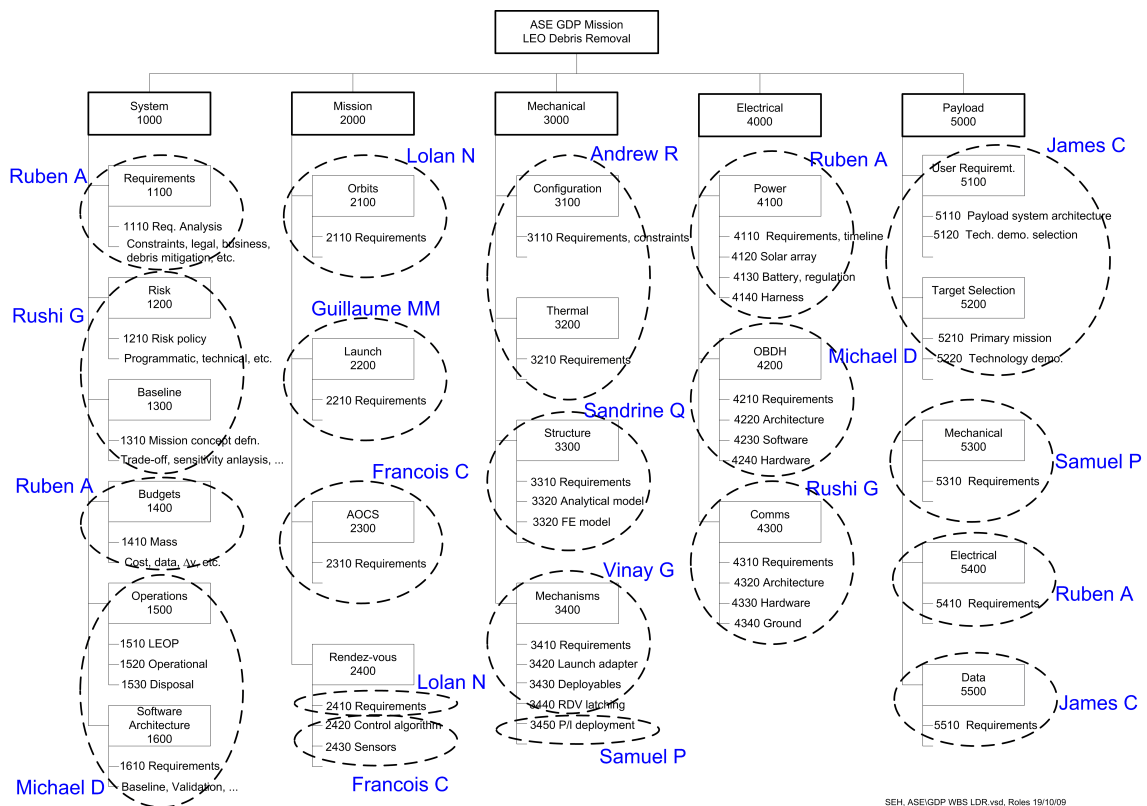

Figure 1.2: Work breakdown structure for the LEO Debris Removal project DR LEO.

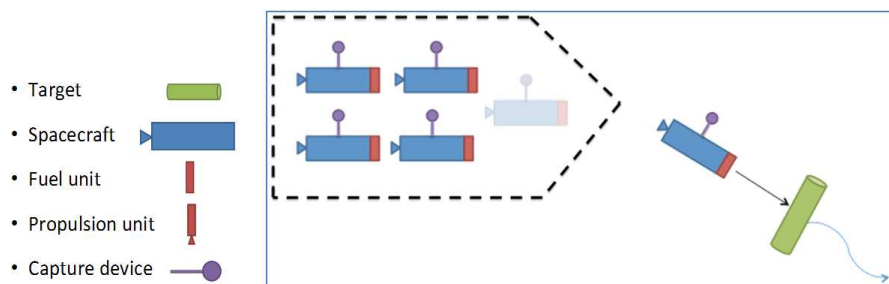

Figure 1.3: Summary of the baseline concept for DR LEO: a stack of 5 similar spacecraft is launched together, each spacecraft has rendezvous and docking equipment; each spacecraft in turn performs a rendezvous with its target object and de-orbits it using atmospheric re-entry over the South Pacific.



# Chapter 2

## Technical Discussion

The student team developed a broadly credible baseline design for an active debris removal mission for low Earth orbit. This chapter discusses specific technical points (further work and suggestions for design modifications are considered in the final chapter). Appendix B provides a quantitative summary of the baseline mission designed so this information is not repeated here. More detailed information for each sub-system area are contained in the executive summaries (Appendix C) and in the individual reports written by each student. The following sections provide brief comments on key issues for each sub-system area.

### 2.1 System

System design included managing the mission requirements, risk, and the various budgets (mass, power, etc.). It also included management of the baseline definition process.

#### 2.1.1 Requirements and Constraints

The project started with a set of initial requirements and constraints which were analysed and modified slightly before starting the main project.

##### Original Requirements and Constraints

The original requirements for the mission were:

1. Rendezvous with 10 large debris items (tbd) (orbit height in the region 850–1000 km) and change their orbits such that they each re-enter Earth's atmosphere within 5 years using a conventional chemical propulsion system.
2. No additional debris items >5 mm may be released or cause to be released by the disposal operation.
3. Demonstrate at least two novel de-orbit technologies chosen from
  - momentum exchange tether
  - electrodynamic tether
  - deployable drag sail
  - low thrust propulsion unit
  - laser ablation deflection
4. Probability of mission success (from launch) should be at least 95% (satisfy the first three requirements)

Some constraints were defined to provide further realism for the project:

1. Mission and its disposal operations should be compatible with current IADC space debris mitigation guidelines (IADC, 2002) and their implementation as ISO standards (e.g. ISO DIS 24113)
2. Use technology suitable for manufacture and integration by 2015 (i.e. currently available or high TRL); European technology to be used except where no alternative exists
3. The mission cost should not exceed €250M (FY 2010) including development, manufacture, launch and operations.
4. The whole mission (launch to the start of its own disposal phase) should take no longer than 5 yr so that timely results are obtained and the risk of hazardous collision with existing debris is minimised.
5. A single operations control centre in Europe should be assumed for the mission. Use of EDRS (GDP 2008/09) may be assumed using up to 10% of bandwidth.
6. The risk of failure modes (e.g. sensor failure) causing a hazard to other spacecraft or the debris environment should be minimized.

### Requirements and Constraints for DR LEO

In discussion of these original requirements it soon became apparent that the underlying objectives were

1. to develop a credible “conventional” technology baseline mission which could act as a benchmark against which other mission proposal could be compared,
2. to reduce future *collision risk* as cost-effectively as possible. This was expressed as removing *mass* from low Earth orbit as cost-effectively as possible, i.e. to minimize the specific cost (e.g. \$ per kg) of mass de-orbited, and is related to the criterion used by Liou (2008) to determine which objects to prioritize. Since orbit changes, rendezvous, and docking are costly or difficult procedures in general, it was assumed that it would be less expensive to remove a few large objects than many small ones.

The main differences in the requirements which the team actually worked to are (1) only 5 targets were de-orbited, (2) the target orbits were close to 800 km rather than 850–1000 km, and (3) the 5 targets had to be de-orbited within 1 year. The third of these provided a somewhat artificial constraint; relaxing it would reduce mission cost although we have not quantified the potential reduction.

#### 2.1.2 Baseline Selection

This was a difficult part of the project because so many different mission architectures are possible and at an early stage in the project there is little quantitative evidence on which to base decisions. With the luxury of additional time it would be worth revisiting the baseline architecture selection step to evaluate alternative designs (one such alternative is suggested in Section 3.1.2 and evaluated in Appendix A).

## 2.2 Mission

The initial design is based on basic optimizations of the manoeuvre costs for the mission. More sophisticated tools could be used to validate these initial results and to perform sensitivity studies. AOCS is closely related to the rendezvous, grappling, and docking tasks which are at the core of this mission. Developing safe, reliable, and robust methods for these tasks is not trivial. We note that the dynamics of the relative motion of the target and chaser are described using equations such as Hill’s equations, with one complete orbit of one object relative to the other each Earth orbit.

Optimum mission design requires good integration of the launcher performance with the mission. Areas where extra performance can be achieved include delivering the maximum mass to the desired orbit, and perhaps exploiting the self-disposal of the launcher to also remove some space debris.

### 2.2.1 Requirements Analysis: Mission

Aspects of basic orbit dynamics can be used to quantify implications of the requirements or mission concepts in several areas.

#### Orbit Transfers

The lifetime of spacecraft left in orbit as a function of orbit height are given in Table 2.1, and the  $\Delta V$  to maintain orbit at these heights are given in Table 2.2. The  $\Delta V$  required to de-orbit from the given heights by lowering the perigee to 50 km is given in Table 2.2. Increasing the perigee height to 100 km, say, would make the re-entry point less precisely controlled but would not reduce the  $\Delta V$  needed by much. To change orbit height between two circular orbits at heights between 300 and 1 000 km the  $\Delta V$  required ranges from 0.54 to 0.50 m s<sup>-1</sup> km<sup>-1</sup>, or 54–50 m s<sup>-1</sup> (100 km)<sup>-1</sup>.

The orbit inclination change  $\Delta V$  ranges from 135 to 128 m s<sup>-1</sup> deg<sup>-1</sup>.

Fortescue, Stark and Swinerd (2003, p. 96) gives an expression for the rate of change of right ascension of the ascending node (RAAN,  $\Omega$ ). Figure 2.1 shows this rate of precession of circular orbits (equation 2.1) with inclination 98° relative to an orbit at 800 km due to the  $J_2$  gravitational perturbation ( $J_2 = 1.0826 \times 10^{-3}$ ). Thus a natural orbit relative precession rate of 0.1° day<sup>-1</sup> (e.g. for an orbit height of 600 km) corresponds to a  $\Delta V$  of approximately 0.1° day<sup>-1</sup> × 130 m s<sup>-1</sup> deg<sup>-1</sup> = 13 m s<sup>-1</sup> day<sup>-1</sup>. This is equivalent to a thrust of 150 mN acting continuously on satellite of mass 1 t ( $F = m \frac{\Delta V}{\Delta t} = 10^3 \frac{13}{86400} = 0.15$  N).

$$\begin{aligned}\bar{\Omega} &= \Omega_0 - \frac{3}{2} \frac{J_2 R_E^2}{a^2 (1 - e^2)^2} \bar{n} t \cos i + O[J_2^2] \\ \frac{d\Omega}{dt} &= -\frac{3}{2} \frac{J_2 R_E^2}{a^2 (1 - e^2)^2} \bar{n} \cos i \\ &= -\frac{3}{2} \frac{J_2 R_E^2}{a^2 (1 - e^2)^2} \sqrt{\frac{\mu}{a^3}} \cos i\end{aligned}\tag{2.1}$$

Table 2.1: Estimated orbit lifetime for satellites starting at various orbit heights starting at the times of solar minimum and solar maximum (Wertz and Larson (1999), assuming  $m/C_{DA} = 50$  kg m<sup>-2</sup>).

Orbit height km	Solar min.	Solar max.
350	196 d	31 d
400	1.5 yr	77 d
450	2.4 yr	181 d
500	3.3 yr	1.1 yr
600	7.1 yr	9.4 yr

#### Disposal by Atmospheric Re-entry

Atmospheric re-entry is an effective way of permanently disposing of space debris. There is however a safety risk for large debris items that they do not completely burn-up during re-entry, and as much as 40% of the mass may survive to Earth’s surface. Over populated areas this causes a risk higher than allowed by current re-entry practices and so for large items it is important to target re-entry over sparsely-populated regions, e.g. the South Pacific.

Table 2.2:  $\Delta V$  required for orbit maintenance or to de-orbit by lowering the perigee to 50 km from an assumed circular initial orbit (Wertz and Larson (1999), assuming ballistic coefficient ( $m/C_{DA}$ ) = 50 kg m<sup>-2</sup>,  $\Delta V \propto 1 /$  ballistic coefficient).

Orbit height km	$\Delta V$ to Maintain orbit		De-orbit $\Delta V$ m s <sup>-1</sup>
	Solar min. m s <sup>-1</sup>	Solar max. m s <sup>-1</sup>	
350	43.7	311	88
400	13.6	140	102
450	4.6	66.6	116
500	1.6	32.9	130
600	0.3	8.8	157
700			183
800			208

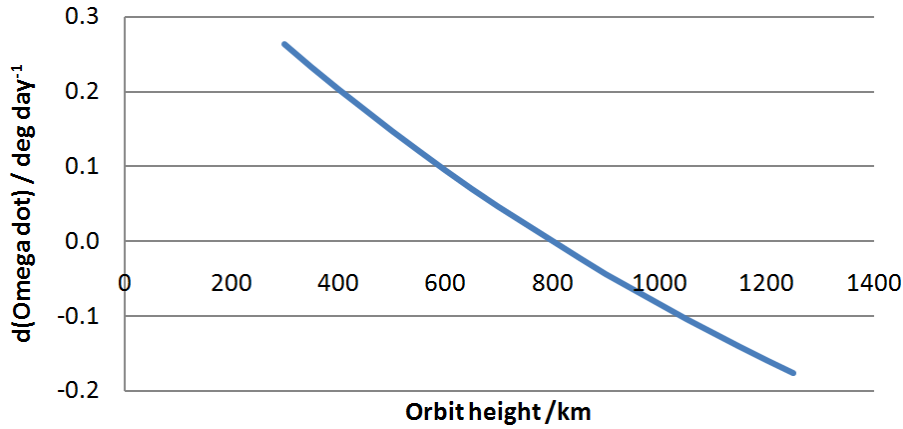

Figure 2.1: Difference in rate of RAAN precession between parking and target orbits for a target orbit height of 800 km as a function of parking orbit height (all orbits assumed circular with inclination = 98.6°).

Accurately targetted re-entry is not possible using low-thrust technologies and so safe disposal seems to require high thrust for at least the final manoeuvre. If many re-entry manoeuvres are planned, as in the proposed active debris removal rate of 5 or more large objects per year, then it seems that accurate re-entry becomes crucial if risk is to be managed satisfactorily.

## 2.3 Mechanical

All areas of mechanical design have challenges. Configuration is difficult given the constraints (i.e. the limited launcher capacity and the varied mission functions, e.g. propulsion, communication, grappling and docking with the target, and power raising). The mechanical design has only been the subject of an initial design because much necessary information was only available late on in the project. The mechanisms (including payload robotic arm) are a crucial part of the mission and in terms of the grappling and docking functions represent the most significant technical challenge for the whole mission. Redundancy in the mechanisms may be important to achieve the required mission reliability.

## 2.4 Electrical

Many spacecraft function reliably in LEO so in principle the electrical design should not pose major challenges. However, the challenges that there are probably centre on the generation of sufficient electrical power given the manoeuvres the spacecraft have to perform in certain critical phases (e.g.

initial grappling of the un-cooperative, tumbling target), and in managing the communication link so that appropriate communication is maintained despite limitations of ground station visibility. It seems that the spacecraft will require a significant degree of autonomy which will affect the data handling system design.

Of the experimental payloads to be evaluated, the use of electric propulsion would clearly impact on the design of the power sub-system by increasing demand by around 1.2 kW (see Table B.7 for the power demand of the chaser spacecraft with electric propulsion called Yuki 1 relative to Yuki 2–5). The larger array has a direct impact on configuration although in the current design the single solar panel is simply lengthened to provide the necessary extra area.

## 2.5 Payload

As already mentioned, the mission’s main technical challenge is probably the grappling and then docking with an un-cooperative, tumbling target which may be several times larger than the de-orbit spacecraft. Although a solution in principle has been proposed, its feasibility has not been confirmed operationally. These functions require close integration of AOCS, robotics technologies, and spacecraft autonomy, which together pose a significant challenge.

The mission’s goal is to develop a “conventional” baseline but it is believed that some alternative technologies have the potential to significantly reduce the cost of debris removal. The design of the experiments to test / demonstrate aspects of these technologies needs careful thought to ensure that the experiments contribute usefully to developing or demonstrating the technology.

### 2.5.1 Target Selection

Ariane IV launcher upper stages were chosen as the target because they have high mass, are in a densely-populated orbit region, and are European. They are clearly a high priority for early debris removal missions from Europe. However, for a significant reduction in collision risk it will be necessary to remove a wider range of targets from different orbits, and so it is an advantage if the mission concept can be adapted easily other types of target.

### 2.5.2 Requirements Analysis: Grappling and Docking

The core of the mission concept is to separate the tasks of (a) grappling and then (b) docking with the target to be de-orbited. This section analyses the requirements to quantify some of the key functions. The target is assumed to be tumbling slowly at an unknown rate. Important basic parameters are listed in Table 2.3.

Once the target has been chosen it is necessary to propose ways of interacting with the target to control its orbit. Most methods proposed require physical contact as has been chosen for DR LEO. Obtaining the most complete information about the expected condition of the targets at time of rendezvous is important, but in this case the students had relatively little information available. A DLR concept of using the nozzle for rendezvous and docking has been adopted, although how feasible this is for a defunct upper stage is not clear (the nozzle may still have (friable?) propellant residue on it or be corroded, and its gimbal mechanism may not be locked). An alternative is to use the docking adapter ring which is less likely to be damaged and should be more firmly attached to the main structure, but which may require more complicated mechanisms for grappling firmly.

The largest moment of inertia is perpendicular to the target’s axis, therefore we assume that most of the angular momentum is about this axis. For an angular velocity of 1 rpm =  $2\pi/60 = 0.105 \text{ rad s}^{-1}$ , the angular momentum is approximately  $1730 \text{ kg m}^2 \text{ s}^{-1}$ , which will have to be cancelled eventually using the AOCS thrusters (e.g. 20 N thrust tangentially at 5 m from the centre of mass for 17.3 s, although an unbalanced thrust like this would lead to a slight orbit change). Note that the tumbling needs to be stopped while the robotic arm is attached and before docking happens otherwise the target will still be tumbling during docking.

Figure 2.2 shows the target docked with the de-orbit spacecraft. The position ( $l_0$ ) of the centre of mass of the docked target and de-orbit spacecraft (of total mass  $m_0$ ) is calculated using

$$m_2(l_0 + d + l_2/2) = m_1(l_1/2 - l_0) \quad (2.2)$$

Table 2.3: Mass properties assumed or estimated for the Ariane IV upper stage, the de-orbit spacecraft, and for the docked combination. The Ariane IV moments of inertia (derived in Table 2.5) are estimated assuming the mass is half as a uniform cylinder and half as a cylindrical shell, the spacecraft mass is from Table B.2 and its height estimated from Figure B.2, and the docking device length is assumed to be 1 m (a specific value does not appear to be stated in the reports). The moment of inertia of the combined target & spacecraft about its centre of mass is estimated using the parallel axes method ( $I = I_0 + my^2$ ).

Parameter	Value
Ariane IV upper stage	
mass	1600 kg
length	11 m
diameter	2.7 m
moments of inertia	
about axis	2187 kg m <sup>2</sup>
perpendicular to axis	16498 kg m <sup>2</sup>
De-orbit spacecraft	
mass	584 kg
length	0.930 m
width	2.0 m
moments of inertia	
about axis	389 kg m <sup>2</sup>
perpendicular to axis	237 kg m <sup>2</sup>
Combined	
mass	2184 kg
length	12.93 m
CoM from target base	3.64 m
moments of inertia	
about axis	2576 kg m <sup>2</sup>
perpendicular to axis	37490 kg m <sup>2</sup>

$$l_0 = \frac{m_1 l_1 - m_2(l_2 + 2d)}{2(m_1 + m_2)} \quad (2.3)$$

$$m_0 = m_1 + m_2 \quad (2.4)$$

The angular momentum of the target docked with the spacecraft will be the sum of the original angular momenta, i.e. 1730 kg m<sup>2</sup> s<sup>-1</sup> assuming the spacecraft was not rotating at the start of the grappling. Since the combined moment of inertia has increased, the angular velocity decreases to 1730/37490 = 0.0461 rad s<sup>-1</sup>. The change in the target's angular momentum is therefore approximately 16498 × (0.105 - 0.0461) = 972 kg m<sup>2</sup> s<sup>-1</sup> (e.g. a torque of 50 N m acting for 19.4 s is what the robotic arm should sustain, in addition to other loads due to the two objects accelerating to start orbiting about a common centre of mass). The relative angular velocity varies from 0.105 rad s<sup>-1</sup> to 0, i.e. an average of 0.05 rad s<sup>-1</sup>. Over 20 s, the relative angular displacement is therefore approximately 1 rad: this is the arc length over which the robotic arm must maintain contact and provide the torque.

Due to the “centrifugal” force, the robotic arm will be in tension during the grappling. An estimate of the magnitude of this force is obtained from  $F = \frac{mv^2}{r} = mr\omega^2$ . This is approximately 584 × (3.64 + 1 + 0.93/2) × 0.0461<sup>2</sup> = 6.3 N which does not seem very demanding. Higher forces are implied by the torque (e.g. 50 N m = opposing forces of 500 N acting 0.1 m apart) and a design safety margin is required for all these forces.

### 2.5.3 Technology demonstration payloads

The study's main purpose is to develop a conventional technology baseline, but it is expected that some advanced technologies will provide better performance. In general, these technologies have not been fully demonstrated yet and so a secondary purpose of the mission was to provide an

Table 2.4: Formulas used to estimate moments of inertia for the target (modelled as a cylinder of mass  $m$ , length  $l$ , and radius  $r$ ) and de-orbit spacecraft (assumed to be a rectangular box of sides  $a$ ,  $b$  and depth  $c$  with uniform mass distribution) (Castle, 1973).

Shape	Moment of inertia	Formula
Hollow cylinder	about axis	$mr^2$
	perpendicular to axis	$ml^2/12$
Uniform cylinder	about axis	$mr^2/2$
	perpendicular to axis	$m(l^2/12 + r^2/4)$
Rectangular plate	about axis	$m(a^2 + b^2)/12$
	parallel to side "b"	$m(a^2 + c^2)/12$

Table 2.5: Estimated values of the moments of inertia for the Ariane IV upper stage using the values of Table 2.3 and assuming the mass distribution is half as a uniform cylinder and half as a cylindrical shell.

Moment of inertia	Uniform cylinder	Hollow cylinder	Total
About axis / kg m <sup>2</sup>	729	1458	2187
Perpendicular to axis / kg m <sup>2</sup>	8431	8067	16498

opportunity to demonstrate key technologies to prepare / evaluate them for use in debris removal. The two technologies chosen are (a) electrodynamic tether and (b) electric propulsion.

Electrodynamic tethers have good potential for low-inclination orbits: the main challenge is reliable deployment and retrieval of the tether. It will also be necessary to demonstrate that the necessary current in the tether can be generated by completing the circuit through the ionosphere and their controllability.

Electric propulsion is closer to operational use: it is already used for geostationary orbit control and examples of significant orbit change have been demonstrated. For use on a tug, the propulsion system needs to have relatively high thrust, good reliability, and to operate for long periods (perhaps a few years). It is unlikely that electric propulsion can serve the whole mission, and so ways to optimise the design of hybrid systems are needed (e.g. chemical propulsion for rendezvous, docking, and the final de-orbit burn, and electric propulsion for the major orbit changes).

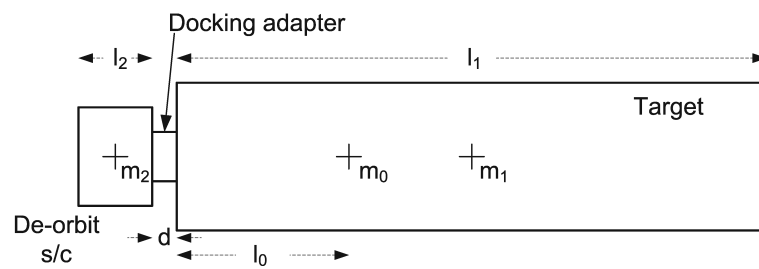

Figure 2.2: Simple model for the docked target and de-orbit spacecraft to estimate approximate moments of inertia. The target has length  $l_1$ , the de-orbit spacecraft  $l_2$ , and the offset of the combined centre of mass from the end of the target is  $l_0$ ;  $d$  is the length of the docking device used to join the target and spacecraft and  $m_i$  are the respective masses.



# Chapter 3

## Discussion and Conclusions

This chapter provides brief discussion of the project’s findings, a summary of its conclusions, and some suggestions for further work.

### 3.1 Discussion

The study represents the output of only one complete design iteration by a team which initially had little experience of space engineering (i.e. MSc students at the start of their course). That a credible design has been developed is a significant achievement in itself. The study has raised many questions requiring further study and has established a benchmark against which future studies can be compared. Some points worthy of further discussion / clarification are covered below.

#### 3.1.1 Budgets

The budgets presented at the end of this first design iteration all deserve scrutiny to validate the results and to look for opportunities for significant improvement. Questions which this analysis could consider include:

- Mass: why is the launch adapter not left attached as much as possible to the Soyuz Fregat upper stage?
- Could Fregat be used as a tug to take some debris out of orbit in addition to de-orbiting itself?
- What are the main cost drivers and how can they be used to optimise performance?

#### 3.1.2 Baseline

The suggested baseline is credible and has several attractive features. The baseline design should be subject to at least a second iteration now that quantitative results are available for most key design areas.

One alternative mission architecture which seems worth consideration is presented in Figure 3.1 and discussed in more detail in Appendix A. This is similar to DR LEO except that the parking orbit may be below rather than above the targets. An advantage of this is that in case of failure of any spacecraft in the parking orbit, atmospheric drag will remove the spacecraft from orbit relatively quickly whereas at 1200 km the natural lifetime of debris is extremely long. Since the mission is short, the drag will not be a significant cost to the mission fuel budget. Further advantages are that more mass can be delivered to the lower parking orbit and that other options such as using a reusable shuttle spacecraft to rendezvous with debris and bring it to the parking orbit may be possible (e.g. the shuttle could then “hand-over” the debris to cheaper de-orbit units for final disposal, although orbit phasing will not be trivial). Tables 2.1 and 2.2 provide information on which the costs / benefits of alternative architectures such as this can be quantified.

Results shown in Appendix A suggest that lowering the parking orbit height to around 400 km brings significant benefits in the amount of debris which can be removed and thus lowers the specific cost of debris removal.

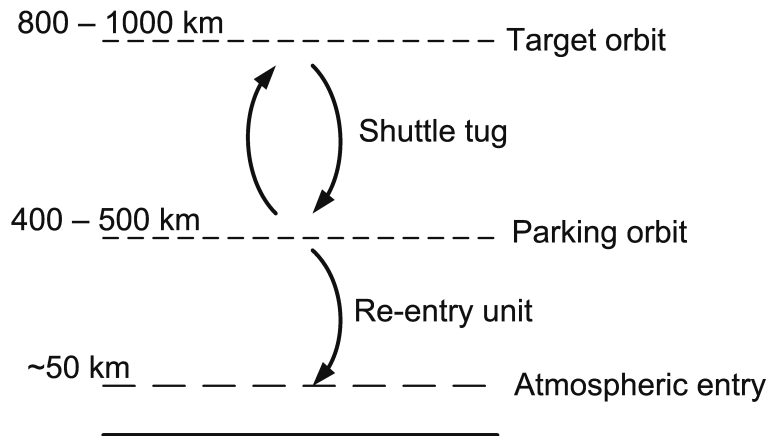

Figure 3.1: Alternative mission architecture based on a shuttle spacecraft which performs rendezvous with targets in the orbit range 800–1000 km and transfers them to a parking orbit at 400–500 km. Either the shuttle or a separate de-orbit unit is used to re-enter the target into Earth’s atmosphere for final disposal.

## 3.2 Conclusions

This first design iteration suggests that a credible “conventional” active debris removal mission can be developed within a budget of approximately €250 M. The prime ESA-nation-state targets are Ariane IV upper stages in Sun-synchronous orbits near 800 km altitude, and the estimated cost of debris mass removed is equivalent to approximately €20–30 k kg<sup>-1</sup>. The lower figure assumes a parking orbit around 400 km (which also lowers mission risk) and that the chaser spacecraft dry mass can be reduced by 15%. Mass reduction may not be easy but it seems clear that more chasers can be deployed if a lower parking orbit is used and so the specific cost can be kept around €25 k kg<sup>-1</sup> or less (it may be better to think of the cost per “tonne-class” object removed since removing one large object is likely to be cheaper than removing many small ones).

The main technical challenge is the grappling and docking with large objects of only partially-known condition which might be tumbling at an unknown rate. It is likely that the rates will be unknown until the final stages of rendezvous unless a precursor mission to document potential targets is used. Current re-entry safety guidelines imply that a targetted re-entry over an uninhabited region such as the South Pacific is needed and therefore that the final de-orbit manoeuvre requires high thrust. (However, since debris removal implies a *series* of re-entries of large debris we suggest that it may be appropriate to re-evaluate the existing re-entry safety criteria for such missions - overly conservative regulations may significantly increase mission cost.)

It is likely that the mission cost can be reduced by using more advanced propulsion technology (e.g. electro-dynamic tether, electric propulsion).

A significant achievement of this study is that it sets a benchmark against which future studies perhaps using advanced technologies can be compared: this was the project’s purpose.

## 3.3 Future Work

As with any feasibility study like this, there are areas of further work where more study would usefully improve the proposal. Some of the areas where we would like to see more work are listed below.

- At least one more design iteration to test the assumptions made in proposing the mission concept and perhaps to incorporate modest changes so that a coherent and credible mission design can confidently be proposed. A lower parking orbit and architectures which allow the grappling mechanism to be re-used (avoiding the need for multiple copies of this key technology which are currently only used once) seem particularly worth investigating.

Other technical issues for further study include:

- The internationally agreed re-entry safety criterion needs careful evaluation to determine how important it is to have accurate control of the re-entry location: precise control may impose significant extra costs.
- Grappling a non-cooperative tumbling target which is not designed for rendezvous is a major technical challenge. This is probably the main technical challenge for active debris removal.
- How would the mission change if different targets were chosen with different orbits?
- How does cost scale with target mass and for different targets, and more generally how can cost relative to “performance” be minimised for this mission concept?
- Which alternative mission architectures are most promising? Can one architecture deal with all debris removal or will a family of missions be needed?
- Do novel propulsion systems add value, and if so, which ones and how much?



# Bibliography

- Amengual, Ruben (2010). ‘DR LEO: Debris Removal from Low Earth Orbit, Requirements, Budgets, and Power’. Group project report, MSc in Astronautics and Space Engineering. School of Engineering, Cranfield University.
- Castle, F. (1973). *Five-figure logarithmic and other tables*. Macmillan Education Ltd., Basingstoke, London.
- Caullier, Francois (2010). ‘DR LEO: Debris Removal from Low Earth Orbit, AOCs and Rendezvous’. Group project report, MSc in Astronautics and Space Engineering. School of Engineering, Cranfield University.
- Cole, James (2010). ‘DR LEO: Debris Removal from Low Earth Orbit, Payload Requirements, Target Selection, Payload Data’. Group project report, MSc in Astronautics and Space Engineering. School of Engineering, Cranfield University.
- Demel, Michael (2010). ‘DR LEO: Debris Removal from Low Earth Orbit, Operations, Software Architecture, OBDH’. Group project report, MSc in Astronautics and Space Engineering. School of Engineering, Cranfield University.
- Fehse, W. (2003). *Automated rendezvous and docking of spacecraft*. Cambridge University Press.
- Fortescue, Peter, John Stark and Graham Swinerd (2003). *Spacecraft systems engineering*. Wiley.
- Ghadawala, Rushi (2010). ‘DR LEO: Debris Removal from Low Earth Orbit, Baseline, Risk, and Communications’. Group project report, MSc in Astronautics and Space Engineering. School of Engineering, Cranfield University.
- Grama, Vinay (2010). ‘DR LEO: Debris Removal from Low Earth Orbit, Mechanisms’. Group project report, MSc in Astronautics and Space Engineering. School of Engineering, Cranfield University.
- Isakowitz, S.J., J.B. Hopkins and J.P. Hopkins (2004). *International reference guide to space launch systems*. AIAA, Reston, VA, USA.
- Klinkrad, Heiner, and Nicholas Johnson (2009). ‘Space debris remediation concepts’. In: *Proceedings of the 5th European Conference on Space Debris, Darmstadt, 30 Mar–2 Apr 2009*.
- Liou, J.-C. (2008). ‘An assessment of the current LEO debris environment and what needs to be done to preserve it for future generations’. In: *Proceedings 26th International Symposium on Space Technology and Science, 2–6 June 2008, Japan*.
- Liou, J.-C., N.L. Johnson and N.M. Hill (2010). ‘Controlling the growth of future LEO debris populations with active debris removal’. In: *Acta Astronautica* 66. 648–653.
- Mathon-Marguerite, Guillaume (2010). ‘DR LEO: Debris Removal from Low Earth Orbit, Launch and Propulsion’. Group project report, MSc in Astronautics and Space Engineering. School of Engineering, Cranfield University.
- Naicker, Lolan (2010). ‘DR LEO: Debris Removal from Low Earth Orbit, Orbits, Rendezvous Requirements’. Group project report, MSc in Astronautics and Space Engineering. School of Engineering, Cranfield University.
- Perez, Edouard (2006). Soyuz from the Guiana Space Centre User’s Manual. Tech. rep. Arianespace.
- Pin, Samuel (2010). ‘DR LEO: Debris Removal from Low Earth Orbit, Payload: Robotic Arm Design’. Group project report, MSc in Astronautics and Space Engineering. School of Engineering, Cranfield University.
- Quevreur, Sandrine (2010). ‘DR LEO: Debris Removal from Low Earth Orbit, Structure’. Group project report, MSc in Astronautics and Space Engineering. School of Engineering, Cranfield University.

- Ratcliffe, Andrew (2010). 'DR LEO: Debris Removal from Low Earth Orbit, Configuration and Thermal Design'. Group project report, MSc in Astronautics and Space Engineering. School of Engineering, Cranfield University.
- Sidi, M.J. (2000). *Spacecraft dynamics and control: a practical engineering approach*. Cambridge University Press.
- Wertz, J.R., and W.J. Larson (1999). *Space Mission Analysis and Design*. Space Technology Library. Appendix B describes methods of relating geocentric and geodetic coordinate systems. Microcosm Inc., Kluwer Academic Publishers.

# Appendix A

## Optimization of the Parking Orbit

A further partial design iteration was performed following the definition of the mission baseline developed by the DR LEO team in March 2010 to check optimization of the mission architecture. Specifically, the effect of changing the height of the parking orbit was evaluated. This appendix reports the findings of this optimization.

In summary, the optimization uses models of (a) launcher performance (mass delivered as a function of orbit height and inclination) and (b) spacecraft performance (dry mass, propulsion system specific impulse) to see how many targets could be de-orbited as a function of the parking orbit height. Launcher performance is estimated by interpolating the data of Table A.1 and the chaser spacecraft parameters are listed in Table A.2. The targets to be de-orbited are the same as those chosen for the baseline mission plus some similar additional targets (see Table A.3) in case more than five targets can be removed.

h / km	Sun-synchronous		Polar orbit	
	I / deg	mass / kg	I / deg	mass / kg
400	97.03	5270	90	5030
500	97.40	5146	90	5015
600	97.78	5010	90	5000
700	98.18	4880	90	4975
800	98.60	4760	90	4945
900	99.03	4630	90	4915
1000	99.48	4510	90	4880
1100	99.94	4392	90	4843
1200	100.42	4275	90	4805
1300	100.91	4160	90	4765
1400	101.42	4045	90	4720
1500	101.95	3935	90	4680
1600	102.50	3820	90	4640
1700	103.07	3720		

Table A.1: Soyuz launcher capability from Kourou to Sun-synchronous and polar low Earth orbits (values digitized from Figs. 2.7, 2.8 of Perez, 2006)

Figure A.1 summarises the mission concept implemented in the optimization code (IDL program `ADRO.pro`: contact the report's author for details if required). The main optimization task is to evaluate the mass available for chaser spacecraft (and thus the number of targets removed) as a function of the parking orbit height and inclination. Figures A.2 and A.3 show results for two cases. The first is a case similar to that considered in the original baseline with five targets. This shows that a modest mass margin is available with the original parking orbit height of 1200 km but that this increases significantly to a maximum of around 1630 kg if the parking orbit is lowered. There appear to be sharp decreases in mass margin close to parking orbits of 400 km and 97°. This is because this orbit (as well as the targets' orbits) is also practically sun-synchronous, i.e. the relative precession rate is close to 0 (the dashed contours show the parking orbit precession

Parameter	Symbol	Value
Dry mass	$m_{c0}$	550 kg
Drag area	$A$	2.0 m $\times$ 2.0 m
Drag coefficient	$C_D$	2.2
Specific impulse	$I_{sp}$	312 s
Standard gravity	$g$	9.81 m s <sup>-2</sup>
Earth's radius	$R_E$	6378 km
Earth's gravitational const.	$\mu$	$3.989 \times 10^{14}$ N m <sup>2</sup> kg <sup>-1</sup>
Earth's J2 gravity term	$J_2$	$1.0826 \times 10^{-3}$

Table A.2: Assumed chaser spacecraft parameters and values for the Earth gravity parameters

Name	NORAD ref.	height km	inclination deg	RAAN deg
ARIANE 40 R/B	20443	772.77	98.6278	135.0506
ARIANE 40 R/B	21610	763.15	98.6849	148.2152
ARIANE 40 R/B	22830	791.95	98.6247	124.3251
ARIANE 40+ R/B	23561	772.23	98.4873	124.1231
ARIANE 40+3 R/B	23608	610.45	98.2389	304.3863
ARIANE 40 R/B	25261	787.42	98.2256	167.2464
ARIANE 40 R/B	25979	617.80	98.1337	260.9017
ARIANE 40 DEB	35955	789.97	98.6001	124.4851

Table A.3: ADR target debris orbit parameters. All are Ariane IV launcher upper stages assumed to have a mass of 1600 kg, to have circular orbits, for the mean motion to be defined per solar day, and  $R_E = 6378$  km. (Data are for 23 June 2010 from file catalog\_31\_2010\_06\_23.pm from Space-track.org.)

rate relative to an orbit of 780 km and 98.6° which is close to the targets' orbits). Since the relative precession rate is so small and at these low altitudes the long mission time costs a significant amount of fuel to overcome drag, the available margin reduces significantly. Mission durations are otherwise reasonable for heights around 300–400 km but become very long if the relative precession rate approaches 0. Figure A.2 also shows that the parking orbit inclination needs to be very close to the target orbits' inclinations (i.e. near to 98.6°), otherwise there is a large penalty for making the necessary orbit plane changes.

Figure A.3 shows results for a mission removing seven targets. A positive mass margin (i.e. a feasible mission design) is achieved only for parking orbit heights around 300–400 km (the maximum margin is 150 kg). The features showing near 700 km and 98.2–98.4° again correspond to sun-synchronous orbits where the relative orbit precession is very slow. Running the simulation for eight targets suggests that eight chaser spacecraft could be launched if the dry mass of the chaser could be reduced to 470 kg (a 15% reduction): increasing the number of targets removed from five to eight for the same launch cost suggests that the cost per target removed could be reduced by around one third to approximately €20k kg<sup>-1</sup>.



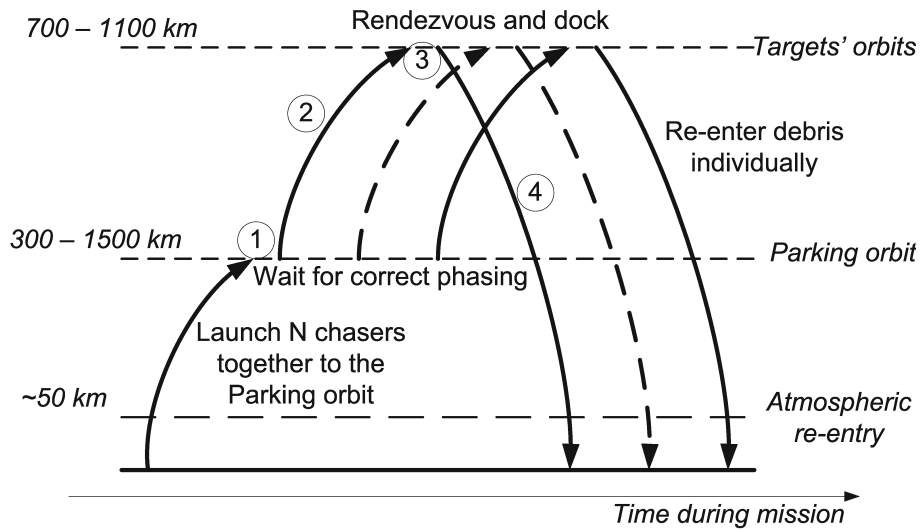

Figure A.1: Overview of the active debris removal concept.  $N$  chaser spacecraft are launched together to a parking orbit where each waits in turn for its orbit to align with its target's orbit plane. When this occurs the chaser transfers to its target's orbit, performs rendezvous and docking, and then de-orbits the debris for atmospheric re-entry. The numbered labels refer to the four steps used to calculate the propellant mass needed (drag cancellation, Hohmann transfer, plane change, and re-entry, respectively).

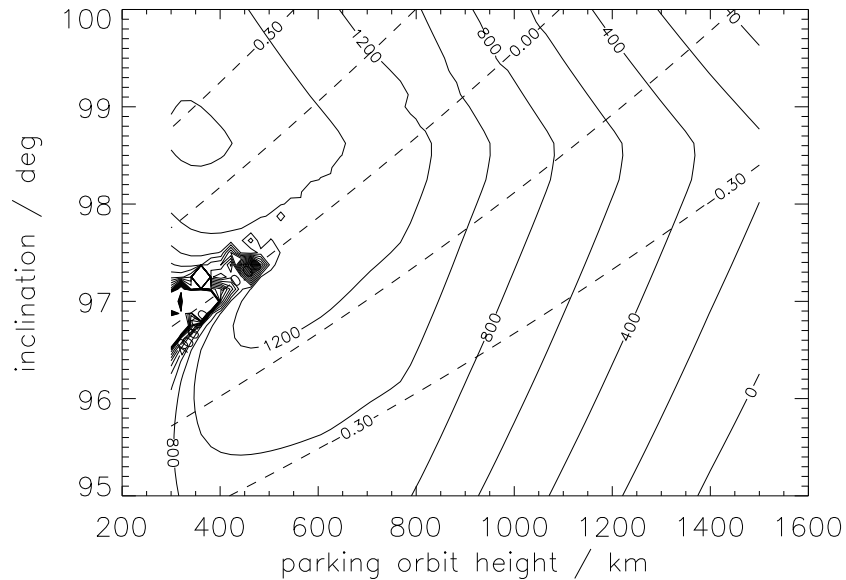

Figure A.2: Mass margin for 5 targets (NORAD ID 20443, 21610, 22830, 23561, 23608) assuming initial RAAN of  $120^\circ$ . The dashed contours show parking orbit precession rate in degrees per day relative to an orbit with  $h = 780$  km and  $i = 98.6^\circ$ .

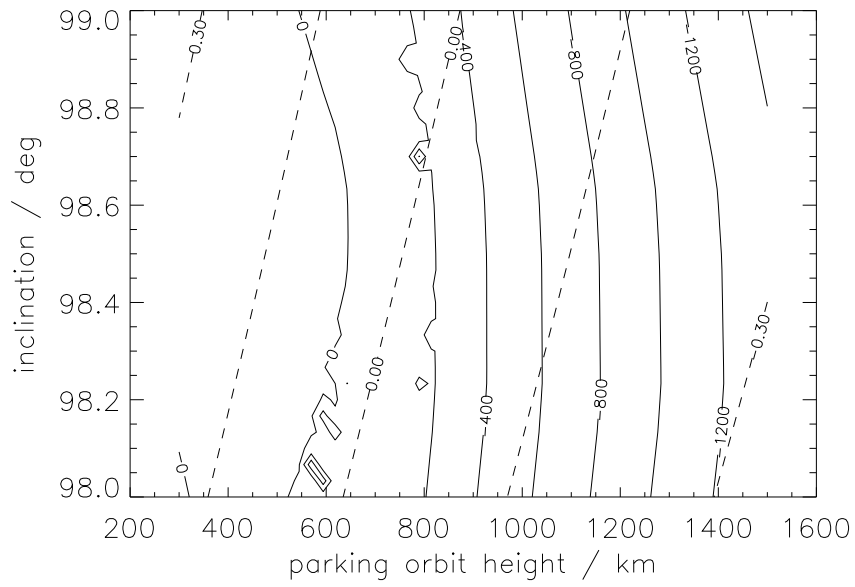

Figure A.3: Mass margin for 7 targets (NORAD ID 20443, 21610, 22830, 23561, 35955, 25261, 25979) assuming initial RAAN of  $120^\circ$ ; only parking orbit heights around 400 km have a positive mass margin and thus are feasible. The dashed contours show parking orbit precession rate in degrees per day relative to an orbit with  $h = 780$  km and  $i = 98.6^\circ$ .

# Appendix B

## Mission Baseline Technical Summary

This appendix summarizes the mission baseline developed to ensure that all team members have a common understanding of its key parameters.

### B.1 Mission objectives

An initial set of mission objectives was proposed to start the project. These were discussed and refined; the requirements and constraints listed below are the agreed ones which formed the basis of the project.

The underlying motivation was to design a mission which could remove the most mass from the most collision-prone orbits at lowest cost. This would be achieved by removing large objects from orbits in the height range 800–1 000 km. The purpose of the study was to establish a baseline design using “conventional” technology (e.g. chemical propulsion) against which more innovative designs could be compared. In this sense the team’s aim was to develop a credible, rather than absolutely optimal, mission design.

An additional requirement to de-orbit the targets within a year was used to see whether it was possible for a single mission to remove five objects, thus satisfying the target debris removal rate identified by Liou, Johnson and Hill (2010) to keep the debris population in LEO stable.

#### B.1.1 Mission statement

A mission statement was agreed to summarize the project’s motivation and purpose:

- Active removal of large and inactive objects in Low Earth Orbit (LEO).
- To provide a method for stabilizing the LEO debris environment.
- Allow sustainable access to space for future generations.

#### B.1.2 Requirements

- R1. Target and efficiently rendezvous with 5 large intact pieces of debris, either spent rocket stages or satellites of European origin, in a region 850–1 000 km, within one year.
- R2. Primary removal achieved using chemical propulsion units capable of directly de-orbiting the targets without compromising other objects in orbit.
- R3. No additional debris items  $> 5$  mm may be released at any stage during the disposal operation.
- R4. Demonstrate at least two novel de-orbit technologies chosen from

1. Momentum exchange tether
  2. Electro-dynamic tether
  3. Deployable drag
  4. Low thrust propulsion unit
  5. Laser ablation deflection
- R5. Probability of mission success (from launch) shall be at least 95% (satisfy R1-R4).

### B.1.3 Constraints

- C1. Mission and its disposal operations shall be compatible with current IADC space debris mitigation guidelines (IADC, 2002) and their implementation as ISO standards (e.g. ISO DIS 24113).
- C2. Use technology suitable for manufacture and integration by 2015 (i.e. currently available or high TRL); European technology to be used except where no alternative exists.
- C3. The mission cost shall not exceed €250 M (FY 2010) including development, manufacture, launch and operations.
- C4. A single operations control centre in Europe shall be assumed for the mission.

## B.2 Baseline

This overview describes the baseline mission selected to fulfil the requirements and mission objective.

The selected baseline mission utilises five separate “chaser” spacecraft to de-orbit chosen debris “targets” in low Earth orbit. The targeted objects are Ariane 40 upper stages. Each chaser spacecraft is equipped with its own propulsion and capture device to fulfil the mission objective.

These five separate chaser spacecraft will be launched on a single launcher. The launcher will place the five chaser spacecraft in a near-polar parking orbit that is at the same inclination as the targets but at higher altitude. This higher altitude parking orbit takes advantage of the J2 perturbation of orbital planes to naturally intercept the orbital planes of the targets over the course of the mission lifetime.

When the orbital planes of the target and chaser align, the chaser transfers from the parking orbit to the target orbit using its own propulsion system. It then ‘captures’ the target using its own capture device.

Once the target is captured, the spacecraft initiates a de-orbit manoeuvre using its own propulsion system.

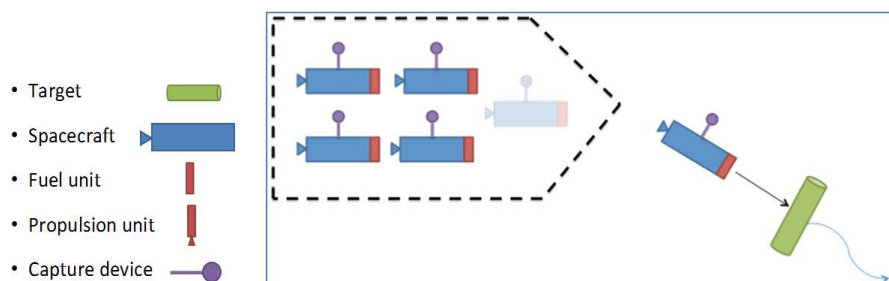

Figure B.1: Summary of the baseline concept for DR LEO: a stack of 5 similar spacecraft is launched together, each spacecraft has rendezvous and docking equipment; each spacecraft rendezvous in turn with its target object and de-orbit it using atmospheric re-entry over the South Pacific.

## B.3 Configuration

Figures B.2 to B.5 show the configuration of the DR LEO spacecraft. The main drivers / derived requirements for the spacecraft configuration are

1. Compact stacking in the launch vehicle to allow several to be launched at once
2. Leave the exhaust nozzle exposed so that it can cool radiatively
3. Keep the design as simple as possible
4. Allow simultaneous communication to Earth and power raising with deployed solar arrays
5. Allow simultaneous communication and grappling during rendezvous (power supplied from batteries)
6. Allow simultaneous communication and power raising while docked and waiting to de-orbit
7. Allow simultaneous communication and thrusting during the de-orbit burns

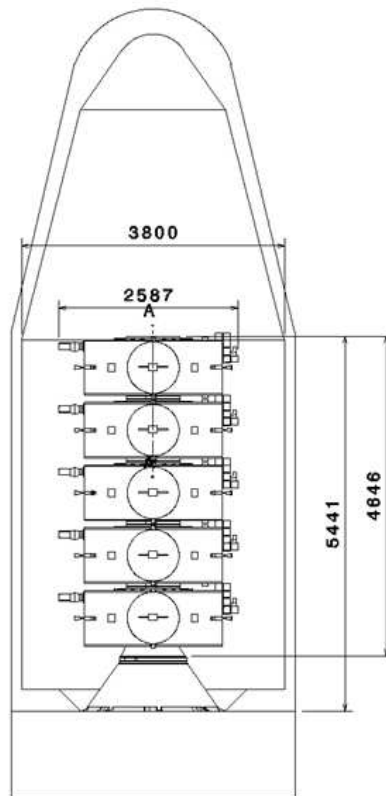

Figure B.2: The five DR LEO spacecraft stacked for launch in the Soyuz fairing (front view, dimensions shown in mm).

## B.4 Mission Timeline

Table B.1 summarises the mission timeline for each of the five chaser (Yuki) spacecraft.

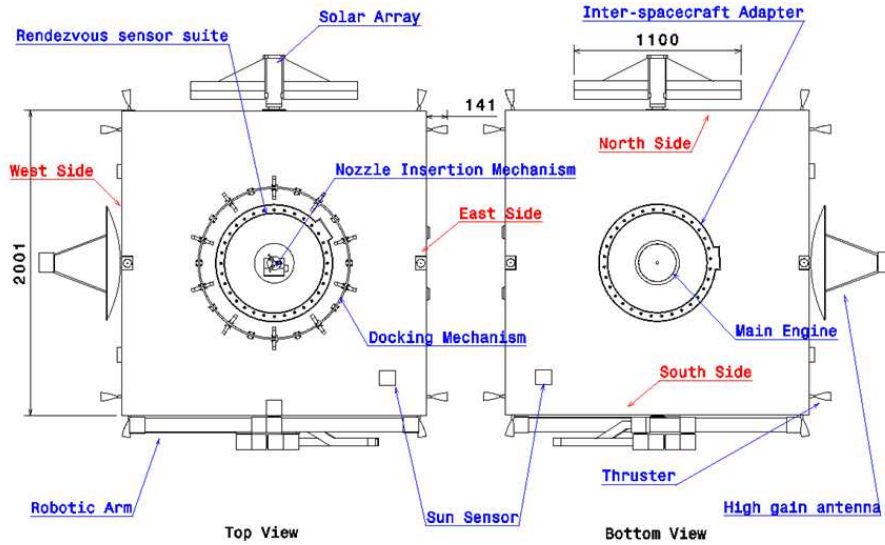

Figure B.3: Top and bottom views of the DR LEO spacecraft (dimensions in mm).

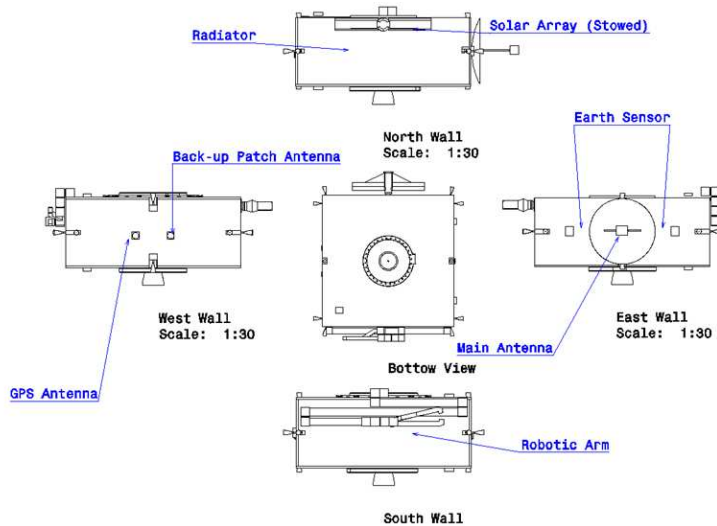

Figure B.4: Side and bottom views of the DR LEO spacecraft (dimensions in mm).

## B.5 System Budgets

Budgets for mass, cost, and power of two mission versions are provided. The standard mission includes all the technology demonstration payloads; the alternative configuration excludes technology demonstration and only includes components needed for the core mission.

### B.5.1 Budgets incl. technology demonstrations

Tables B.2 to B.7 give the mass, cost, and power budgets for the full mission including the technology demonstration payloads.

#### Full mission Mass budget

Table B.2 gives the mass budget for the full mission.

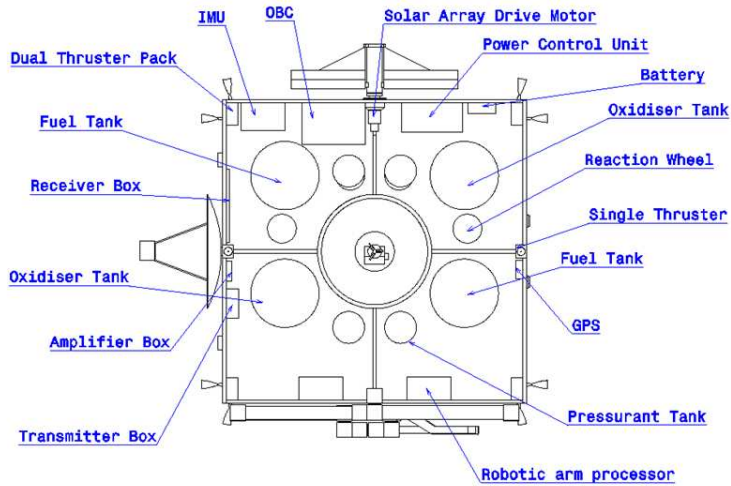

Figure B.5: General configuration for the DR LEO spacecraft.

Table B.1: DR LEO mission operations timelines for each of the five “Yuki” chaser spacecraft.

Yuki	1	2	3	4	5
Transfer technology	electric	chemical for Yuki 2–5			
De-orbit technology	electric	tether & chemical	only chemical for Yuki 3–5		
Launch date	28 Feb 2015 in all cases				
LEOP	< 1 day in all cases				
Commissioning	7 days in all cases				
Cruise	182 days	45 hr	273 days	324 days	327 days
Transfer	34 days	50 min for Yuki 2–5			
Rendezvous	6 hr in all cases				
Capture	1 hr in all cases				
Docking	1 hr in all cases				
De-orbit	100 day + 70 min	331 day + 65 min	65 min for Yuki 3–5		
Mission end	18 Jan 2016	4 Feb 2016	6 Dec 2015	26 Jan 2016	29 Jan 2016

### Full mission Cost budget

Tables B.3 and B.4 give the full mission cost budgets.

### Full mission Power budget

Tables B.5 to B.7 gives the power budget for the full mission.

## B.5.2 Alternative configuration budgets

The alternative configuration includes only the elements needed for the core mission (using chemical propulsion only to de-orbit the targets); all technology demonstration elements are removed. This gives a more realistic estimate of the cost to de-orbit the targets using conventional technology.

### Core mission Mass budget

Table B.8 gives the mass budget for the mission designed without technology demonstration payloads.

Table B.2: DR LEO mass budget

	Yuki 1 (low thrust electric)	Yuki 2 (e-tether, chemical)	Yuki 3, 4, 5 (chemical)
Structure	100.0 kg	100.0 kg	100.0 kg
Engine	6.4 kg	76.3 kg	76.3 kg
Fuel	201.9 kg	231.7 kg	217.6 kg
AOCS+RV	29.3 kg	29.3 kg	29.3 kg
OBDH	25.0 kg	25.0 kg	25.0 kg
Communications	3.0 kg	3.0 kg	3.0 kg
Thermal	20.0 kg	20.0 kg	20.0 kg
Power	70.3 kg	31.1 kg	31.1 kg
Payload	300.0 kg	189.0 kg	69.0 kg
Mechanisms	69.2 kg	17.2 kg	17.2 kg
Subtotal	820.1 kg	717.6 kg	583.6 kg
Margin	36.0 kg	30.9 kg	24.2 kg
Total	861.1 kg	753.5 kg	612.8 kg
Total mass 5 s/c	3453 kg		

Table B.3: Spacecraft cost in million Euro FY 2010 including TFU and insurance (including cumulative improvements from the “learning curve”).

Item	Yuki 1	Yuki 2	Yuki 3	Yuki 4	Yuki 5	Sub-total
S/C TFU	23.8	19.0	16.5	15.9	15.7	90.9
Operations TFU	19.9	15.7	12.9	12.4	12.3	73.2
Insurance	4.4	3.8	3.4	3.4	3.4	18.4
Sub-total	48.1	38.5	32.8	31.7	31.4	182.5

### Core mission Cost budget

Tables B.9 and B.10 give the core mission cost budgets.

### Core mission Power budget

Tables B.11 to B.13 gives the power budget for the core mission designed without technology demonstration payloads.

### B.5.3 Delta-V budget

Table B.14 lists the propulsion requirements as  $\Delta V$  in  $\text{m s}^{-1}$  for the various mission phases and for the different propulsion systems involved.

### B.5.4 Communication link budget

Tables B.15 and B.16 summarise key communication system aspects.

### B.5.5 Data budget

Tables B.17 and B.18 give the initial budgets for sizing the data handling systems.



Table B.4: DR LEO cost budget. The mean cost per kg of debris de-orbited is €39.0 k FY2010 including the cost of technology demonstration payloads.

Item	Cost M€ FY2010
S/C TFU	90.9
Operations TFU	73.2
Insurance	18.4
S/C RDT&E	44.8
Operations RDT&E	34.8
Soyuz launch	50.0
<b>Total</b>	<b>312.1</b>

Table B.5: DR LEO power budget for the parking orbit phase.

Subsystem	YUKI 1-5	
	Average W	Peak W
AOCS&RDV	21.8	70.6
OBDH	35.0	35.0
Comms.	3.0	3.0
Thermal	40.0	75.0
Power	12.0	28.0
Payload	0.0	0.0
Margin	12.0	67.0
<b>Total</b>	<b>123.8</b>	<b>278.6</b>

Table B.6: DR LEO power budget for the capture /docking phase.

Subsystem	YUKI 1-5	
	Average W	Peak W
AOCS&RDV	22.8	72.6
OBDH	35.0	35.0
Comms.	3.0	3.0
Thermal	40.0	75.0
Power	23.0	50.0
Payload	139.0	295.0
Margin	17.0	67.0
<b>Total</b>	<b>279.8</b>	<b>597.6</b>

Table B.7: DR LEO power budget for the travelling or de-orbiting phases.

Subsystem	YUKI 1		YUKI 2		YUKI 3-5	
	Average W	Peak W	Average W	Peak W	Average W	Peak W
AOCS&RDV	21.8	70.6	21.8	70.6	21.8	70.6
OBDH	35.0	35.0	35.0	35.0	35.0	35.0
Comms.	3.0	3.0	3.0	3.0	3.0	3.0
Thermal	40.0	75.0	40.0	75.0	40.0	75.0
Power	39.0	100.0	13.0	29.0	12.0	29.0
Payload	500.0	1 100.0	5.0	10.0	0.0	0.0
Margin	41.0	128.0	13.0	67.0	12.0	66.0
<b>Total</b>	<b>679.8</b>	<b>1 511.6</b>	<b>130.8</b>	<b>289.6</b>	<b>123.8</b>	<b>278.6</b>

Table B.8: DR LEO mass budget

	Yuki 1	Yuki 2, 3, 4, 5
Structure	80.0 kg	80.0 kg
Engine	76.3 kg	76.3 kg
Fuel	200.0 kg	200.0 kg
AOCS+RV	24.3 kg	24.3 kg
OBDH	12.0 kg	12.0 kg
Communications	3.0 kg	3.0 kg
Thermal	20.0 kg	20.0 kg
Power	31.1 kg	31.1 kg
Payload	59.0 kg	59.0 kg
Mechanisms	69.2 kg	17.2 kg
Subtotal	574.9 kg	522.9 kg
Margin	28.8 kg	26.2 kg
Total	603.7 kg	549.1 kg
Total mass 5 s/c	2800 kg	

Table B.9: Spacecraft cost in M € FY 2010 including TFU and insurance (including cumulative improvements from the “learning curve”).

Item	Yuki 1	Yuki 2	Yuki 3	Yuki 4	Yuki 5	Sub-total
S/C TFU	17.4	14.9	14.4	13.9	13.7	74.3
Operations TFU	14.2	11.8	11.4	11.1	10.9	59.4
Insurance	3.2	3.0	3.0	3.0	3.0	15.2
Sub-total	34.8	29.7	28.8	28.0	27.6	148.9

Table B.10: DR LEO cost budget. The mean cost per kg of debris de-orbited is € 31.1 k FY2010 for the core mission with no technology demonstration payloads.

Item	Cost M FY2010
S/C TFU	74.3
Operations TFU	59.4
Insurance	15.2
S/C RDT&E	26.9
Operations RDT&E	23.1
Soyuz launch	50.0
Total	248.9

Table B.11: DR LEO power budget for the parking orbit phase (same as the budget for the full mission).

Subsystem	YUKI 1-5	
	Average W	Peak W
AOCS&RDV	21.8	70.6
OBDH	35.0	35.0
Comms.	3.0	3.0
Thermal	40.0	75.0
Power	12.0	28.0
Payload	0.0	0.0
Margin	12.0	67.0
Total	123.8	278.6

Table B.12: DR LEO power budget for the capture /docking phase (same as the budget for the full mission).

Subsystem	YUKI 1-5	
	Average W	Peak W
AOCS&RDV	22.8	72.6
OBDH	35.0	35.0
Comms.	3.0	3.0
Thermal	40.0	75.0
Power	23.0	50.0
Payload	139.0	295.0
Margin	17.0	67.0
Total	279.8	597.6

Table B.13: DR LEO power budget for the travelling or de-orbiting phases.

Subsystem	YUKI 1-5	
	Average W	Peak W
AOCS&RDV	21.8	70.6
OBDH	35.0	35.0
Comms.	3.0	3.0
Thermal	40.0	75.0
Power	12.0	29.0
Payload	0.0	0.0
Margin	12.0	66.0
Total	123.8	278.6

Table B.14: Delta-V costs for each propulsion system

Propulsion method	Max $\Delta V$ (incl. change) $m s^{-1}$	$\Delta V$ (transfer) $m s^{-1}$	$\Delta V$ (circularization) $m s^{-1}$	$\Delta V$ (testing) $m s^{-1}$	$\Delta V$ (de-orbit) $m s^{-1}$	Total $m s^{-1}$
Chemical	40	100	100		250	490
Electric		200		280		480
AOCS					70	70
Tether				210		210

Table B.15: Main antenna parameters

Antenna diameter	0.75 m
Depth	0.09 m
Horn offset from reflector	0.394 m
Horn size	0.13 m x 0.13 m
Number of struts	2
Antenna mass	3.618 kg

Table B.16: Communication link parameters (power is proportional to data rate and can be scaled from the values given).

Frequency	2.2 GHz
Transmit power (RF)	0.1454 W
Tx antenna diameter	0.75 m
Rx antenna diameter	15.0 m
Data rate	5.00 Mbps
Link margin	3.00 dB

Table B.17: Main processor data budget

Software	Code kwords	Code kbytes	Data kwords	Data kbytes	Throughput kips
Application	33.0	66.0	30.5	61.0	138.0
Executive	15.4	30.8	7.3	14.6	89.8
Total	48.4	96.8	37.8	75.6	227.8
Total baseline	193.6	387.2	151.2	302.4	911.3

Table B.18: AOCs processor data budget

Software	Code kwords	Code kbytes	Data kwords	Data kbytes	Throughput kips
Application	25.7	51.4	8.2	16.4	107.2
Executive	15.4	30.8	7.3	14.6	108.9
Total	41.1	82.2	15.5	31.0	216.1
Total baseline	164.4	328.8	62.0	124.0	864.4

## Appendix C

# Individual Report Executive Summaries

Executive summaries for all the project reports are given in this appendix. Full copies of the reports may be referred to at the School of Engineering, Cranfield University, UK.

The summaries presented here have been only lightly edited. Users of the summaries and reports should bear in mind that although efforts have been made to correct any significant errors, it is possible that some minor errors remain.

The reports are ordered alphabetically by author surname. Figure 1.2 shows the project work breakdown structure and students' individual responsibilities within the project.

Student	Work area
Amengual	Requirements, budgets, electrical power
Cauillier	AOCS
Cole	Payload
Demel	Operations, software, OBDH
Ghadawala	Risk, baseline, communications
Grama	Mechanisms
Mathon-Marguerite	Launch
Naicker	Orbits
Pin	Payload (mechanical)
Quevieux	Structure
Ratcliffe	Configuration

Table C.1: Sub-system responsibilities for each student

## C.1 Executive Summary: DR LEO, Requirements, budgets, EPS, Ruben Amengual

Continuous increase of space debris population is jeopardizing space missions; an active debris removal (ADR) action is proposed. Mission's main statement is to develop a demonstration operation to perform an active removal of large and inactive objects in low Earth orbit, preventing a cascade effect in LEO space debris population due to collisions. This action should be the first one in a continuous removal of space debris allowing sustainable access to space for the current and future generations.

### C.1.1 Requirements and constraints

#### Requirements

1. R1. Mission must target and rendezvous with five large European space debris in LEO and de-orbit them to achieve their destruction due to atmospheric drag forces produced when they re-entry into Earth's atmosphere.
2. R2. Target primary removal will be achieved mainly using chemical propulsion.
3. R3. No additional debris may be released during this mission.
4. R4. Mission should also be able to demonstrate capability of two de-orbiting technologies.
5. R5. The probability of mission success must be at least 95%.

#### Constraints

1. C1. Mission must be compatible to IADC space debris mitigation guidelines and ISO standards.
2. C2. The use of European technology should be fostered where possible for manufacturing and integration by 2015.
3. C3. Mission cost shall not exceed € 250 Million fiscal year 2010.
4. C4. A single operation centre in Europe should be available for mission control.

To achieve mission's requirements, five different spacecrafts will target, rendezvous and de-orbit five Ariane 40 rocket upper stages. One spacecraft will be provided with a low thrust propulsion unit (Yuki 1), another one (Yuki 2) with electro-dynamic tether and chemical propulsion, and three more solely with chemical propulsion (Yuki 3 to 5).

### C.1.2 Budgets

Basic information on mass, cost and power budget is provided next. Further information on  $\Delta V$ , communications and data budgets is also given in the project summary.

#### Mass budget

Next table summarizes mass budget for all 5 spacecraft (Yuki = s/c internal name).

#### Cost budget

Previous table provides mission cost; due to it does not fulfil 3rd constraint, another mission has also been proposed. This alternative configuration provides all s/c with chemical propulsion units, and no demonstration technologies are used. Total cost for this option is € 248.9 M FY 2010, and cost per kg de-orbited is € 31.1 k FY 2010.

	Yuki 1 (low thrust electric)	Yuki 2 (e-tether, chemical)	Yuki 3, 4, 5 (chemical)
Structure	100.0 kg	100.0 kg	100.0 kg
Engine	6.4 kg	76.3 kg	76.3 kg
Fuel	201.9 kg	231.7 kg	217.6 kg
AOCS+RV	29.3 kg	29.3 kg	29.3 kg
OBDH	25.0 kg	25.0 kg	25.0 kg
Communications	3.0 kg	3.0 kg	3.0 kg
Thermal	20.0 kg	20.0 kg	20.0 kg
Power	70.3 kg	31.1 kg	31.1 kg
Payload	300.0 kg	189.0 kg	69.0 kg
Mechanisms	69.2 kg	17.2 kg	17.2 kg
Subtotal	820.1 kg	717.6 kg	583.6 kg
Margin	36.0 kg	30.9 kg	24.2 kg
Total	861.1 kg	753.5 kg	612.8 kg
Total mass 5 s/c	3453 kg		

Table C.3: DR LEO cost budget. The mean cost per kg of debris de-orbited is € 39.0 k FY2010 including the cost of technology demonstration payloads.

Item	Cost € M FY2010
S/C TFU	90.9
Operations TFU	73.2
Insurance	18.4
S/C RDT&E	44.8
Operations RDT&E	34.8
Soyuz launch	50.0
Total	312.1

## Power budget

Power budget is given for different operation configurations. Next table is one of them.

### C.1.3 Electrical Power System (EPS)

EPS generates, stores distributes and control electrical power. Main components are briefly described.

#### Solar array

Flexible blanket solar array with GaAs/Ge single-junction solar cells will be provided for each spacecraft. Main characteristics are the following:

- For Yuki 1 (low thrust propulsion unit), power requirement 1 500 W: solar array's area 13.3 m<sup>2</sup> and solar array's mass 54 kg.
- For Yuki 2 to Yuki 5 (e-tether and chemical propulsion units), power requirement 600 W: solar array's area 5.3 m<sup>2</sup> and solar array's mass 22 kg.

#### Batteries

Li-ion secondary batteries have been provided. For low thrust electric propulsion unit, (peak power demand 1500 W, requiring EBM = 907 Wh), 3 Li-ion batteries plus 1 redundant Li-ion battery parallel-connected configuration is proposed. For chemical propulsion units, including that with electro-dynamic tether (peak power demand 600 W, requiring EBM = 363 Wh), one Li-ion battery plus another redundant Li-ion battery parallel-connected configuration is proposed.

Table C.4: DR LEO power budget for the capture /docking phase.

Subsystem	YUKI 1		YUKI 2		YUKI 3-5	
	Average W	Peak W	Average W	Peak W	Average W	Peak W
AOCS&RDV	22.8	72.6	22.8	72.6	22.8	72.6
OBDH	35.0	35.0	35.0	35.0	35.0	35.0
Comms.	3.0	3.0	3.0	3.0	3.0	3.0
Thermal	40.0	75.0	40.0	75.0	40.0	75.0
Power	23.0	50.0	23.0	50.0	23.0	50.0
Payload	139.0	295.0	139.0	295.0	139.0	295.0
Margin	17.0	67.0	17.0	67.0	17.0	67.0
Total	279.8	597.6	279.8	597.6	279.8	597.6

### Power control, harnesses and payload

Mission requires power control unit to regulate power demand and harness to distribute it. Further information on these aspects and payload power demand is also given.

#### C.1.4 Discussion and conclusion

This project considers an active debris removal (ADR) action for de-orbiting five Ariane 40 rocket upper stages. Five spacecraft will deal with rendezvous, dock, capture and de-orbit these targets.

Cost has been increased during project. Main reason is because mission mass has risen from 2,400 kg in its initial configuration (November 2009) up to 3,450 kg. Configuration proposed for mission's spacecraft does not fulfil cost constraint: estimated cost will be € 312.1 M FY 2010, but cost constraint is not to exceed € 250 M FY 2010. However it is possible to achieve requirements avoiding new demonstration technologies. For this reason an alternative mission configuration has been proposed including five de-orbiting s/c using chemical propulsion units; mission's cost would be € 248.9 M FY 2010. An agreement has to be reached to understand what option will be the most feasible: initial configuration or another without demonstration technologies.

In any case we should consider whether this is a reasonable price for de-orbiting five space debris weighting 8 tons. De-orbit cost will be € 39,000 / de-orbited kg for main configuration (5 s/c with two demonstration technologies) or € 31,100 / de-orbited kg for alternative configuration (5 s/c with chemical propulsion and no demonstration technologies at all).

May be this is a high price for de-orbiting space debris, but it seems it must be done sooner or later. If no ADR action is considered, what options there will be for medium or long term? Could next generations have an easy access to space? Another question that may arise relates whether this technology is a successfully way for de-orbiting space debris. If it is, how can be it adapted to de-orbit other space debris different than Ariane 40 rocket upper stages? It has been checked that demonstration technologies (low thrust propulsion unit and electro-dynamic tether) are the heaviest and most expensive. Should we continue with their use or should chemical propulsion units be fostered? A final reflection may deal with this question: what should future investigations focus on?

It is not clear yet if there is an optimal technology to de-orbit space debris and what will be its cost. In any case, it seems obvious that ADR actions must start sooner or later.



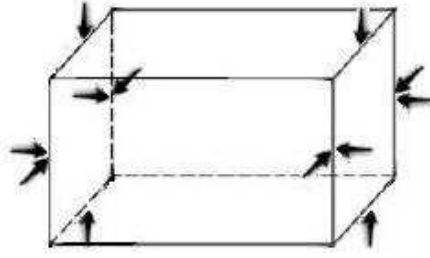

Figure C.1: Thrusters positions

## C.2 Executive summary: DR.LEO, AOCS and Rendezvous, François Caullier

### C.2.1 AOCS

**Top-level design** The ACOS has to control the attitude and the orbit of the spacecraft during every phase of the mission as described in Sidi (2000) and Wertz and Larson (1999). The requirements for each of it are very different, so the task was separated in three main parts: the parking orbit first, then the rendezvous and the capture and finally the de-orbit.

During the parking orbit, the spacecraft will be three-axis stabilised thanks to four reaction wheels. During the rendezvous and even more during the capture, the chaser will use some thrusters to perform them. And then, the spacecraft will be spin before the de-orbit to maintain a gyroscopic control.

**Reaction wheels design** During the parking orbit, the spacecraft has to be 3-axis stabilised to maintain the communication link and the use of the solar panel. So the main requirement of the phase for AOCS is to control every disturbances. Among them, the gravity gradient, the solar radiation and the aerodynamic drag have been estimated.

To perform the control of the spacecraft against these disturbances, four reaction wheels will be implemented to control the attitude. They will be helped by two sun sensors and two earth sensors (one main and one for redundancy).

**Thrusters sizing** The main requirement for the thrusters is to control the target after the capture. As the debris is non-cooperative, it can spin and tumble. These rotations have to be stop before the de-orbit to control the re-entry. So the thrusters are designed by the inertia matrix of the target (plus the one of the chaser), the slew rate of the debris, the robotic arm capability and the time of the capture.

The thrusters selected have a  $22N$  thrust and are placed as shown in the figure C.1.

**Gyroscopic control** Due to the uncertainties of the docking mechanism and the lack of information about the centre of gravity of the target, the thrust vector can be misalign with the centre of gravity of the all body (chaser plus target). To perform an accurate re-entry, the spacecraft will be spin up to use a gyroscopic control.

The design of this gyroscopic control is to determine the slew rate from the maximum precession angle that can be allowed. This relation is given by the following equation, with  $\theta$  the precession angle,  $T$  the torque due to the thrust vector misalignment and  $\mathbf{I}$  the inertia matrix of the body:

$$\omega_z = \sqrt{\cot \theta \frac{2TI_x}{I_z(I_x - I_z)}}$$

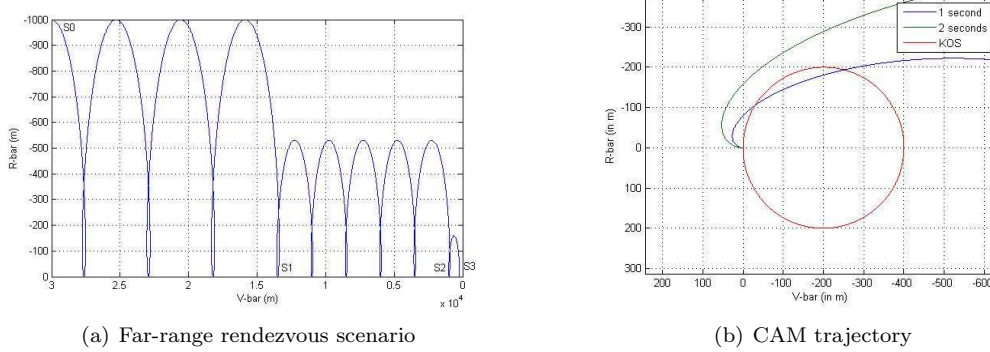

Figure C.2: Rendezvous trajectories

## C.2.2 Rendezvous

**Rendezvous strategy** The rendezvous has to bring the chaser from the end of the orbit transfer to a point where the robotic arm can perform the capture. This trajectory has to be as safe as possible, especially as the target is non-cooperative. This approach will be separated in two parts: the far-range rendezvous and the close-range rendezvous.

The aim of the far-range rendezvous is to get closer of the target (to compensate the uncertainties of the Hohmann transfer) and to collect data about the target (position, slew rate, damages, status of the grabbing point). During the far-range rendezvous, the spacecraft will use a relative positioning navigation but an absolute attitude.

After this first phase, the chaser will perform a close-range rendezvous. In this situation, the chaser will use relative positioning and attitude. The aim is to bring the spacecraft to a point where the robotic arm can capture the debris. As previously, this trajectory has to be safe and avoid any collision.

**Rendezvous scenario** The far-range rendezvous will be performed by a free drift in elliptical orbit as described in Fehse (2003). The difference in altitude between the chaser and the target is producing a relative speed between them. This far-range rendezvous is punctuated by several station keeping on the target altitude ( $S_1$ ,  $S_2$  and  $S_3$ ). These points are used to collect data about the target and wait for a good ground coverage window. These station keeping and the far-range trajectory are given in the figure C.2(a).

After this first phase, the chaser will perform the close-range rendezvous. It will be along  $V$ -bar or  $R$ -bar, depending on the target tumbling axis and the capture strategy. As the far-range rendezvous, the final approach will be punctuated by several station keeping points.

**Sensors** The chaser will use passive and active sensors. First of all, a radar will target the debris and estimate the distance and the direction of the debris. This will be coupled to the relative navigation of the chaser. This hardware will be doubled for redundancy.

In addition to this radar, the spacecraft will use a camera to determine the attitude of the debris and its slew rate. A second camera will be put on the robotic arm to help the capture. Some light will be put on the top of the spacecraft to allow this camera to work even in eclipse.

**Safety** A Keep Out Sphere (KOS) has been defined to make a safe zone around the target and defined the corridor for the close-range rendezvous.

Once this KOS defined, passive and active control has been designed. The passive one are the station keeping point and the free drift. At the station keeping point, there is no relative motion between the chaser and the target, so the chaser can stay there even if there is some failure in any sub-system. The second passive control is the free drift, if the chaser fails any burn to reach a station keeping, it will continue its elliptical orbit and avoid the KOS.

The active control is a Collision Avoidance Manoeuvre (CAM). This manoeuvre is used if the

chaser is going into the KOS. This is a tangential burn to put the chaser away of the target (and away of the KOS). As described in the figure C.2(b), the CAM has to be enough long to not reach the KOS in a second part of the new chaser trajectory.

## C.3 Executive summary: DR.LEO, Payload, James Cole

The objective of the mission was to provide a method of stabilising the LEO debris environment. Possible methods involve ADR of large and intact objects in LEO. The project process involves analysis of these ADR techniques and assessment of their feasibility. As well as this, a cost estimate was to be produced that would indicate the typical cost that could be expected to de-orbit target debris; this could then be expressed as the cost per unit mass de-orbited.

### C.3.1 Target Selection

From the main requirements of the mission it was possible to generate a list of defunct satellites and spent launcher upper stages. This list was then analysed to select targets that would best satisfy these mission requirements and reduce the complexity and cost of the mission. Targets were chosen that would provide a good ratio of cost per unit mass de-orbited.

Table C.5: List of chosen LEO space debris targets

Target Number	Target	NORAD ID
1	Ariane 4 R/B Upper Stage	21610
2	Ariane 4 R/B Upper Stage	22830
3	Ariane 4 R/B Upper Stage	35955
4	Ariane 4 R/B Upper Stage	23561
5	Ariane 4 R/B Upper Stage	20443

The properties of these targets were researched to provide the necessary information to determine the dynamics of the targets in order to develop the required mechanisms needed to de-orbit them.

### C.3.2 Payload User Requirements

The payloads of the baseline spacecraft have been defined as consisting of the mechanism required to capture and de-spin the target debris and the alternative de-orbit technologies that will be tested.

#### Capture Mechanism

A variety of different capture mechanisms were considered. They were assessed for their strengths and weaknesses and whether they would satisfactorily meet the mission's main requirements. The technology chosen, that would best suit the mission requirements, was the robotic arm. It was chosen due to its high TRL and low risk of creating any debris pieces during the capture manoeuvre.

#### Alternative De-orbit technologies

To satisfy the fourth requirement two novel de-orbit technologies were chosen through a trade off process. The purpose of the requirement is to test the capabilities of the de-orbit technologies for future use. The technologies chosen were the electrodynamic tether and low thrust propulsion.

### C.3.3 Electrodynamic Tether

The electrodynamic tether is a long conductive cable that can be lowered from targeted debris. The cable's motion across the Earth's magnetic field induces a current. The current produced generates a drag force in the opposing direction of the target's motion, in effect de-orbiting it.

The electrodynamic tether was chosen as it has good de-orbiting capabilities. Due to the inherent nature of the technology it is less effective in high inclinations. As a result it was decided that its performance in high inclination would be an ideal aspect to test.

### **Use and Testing**

Two electrodynamic tethers will be used to transfer one of the selected targets to an altitude of 300km from its original altitude of 800 km. This process will take approximately 300 days.

During the transfer phase the two EDTs will be used to test two different types of tether, deployment mechanism, tether cable winding mechanism and feedback control system. The results obtained will indicate how the EDT device can be better designed to be more effect, in particular whether the device can really perform adequately in high inclinations.

### **C.3.4 Low Thrust Propulsion**

The most prominent form of low thrust propulsion is electric propulsion. Low thrust propulsion was also chosen as an alternate technology to be tested as it is quite well developed and provides relatively short de-orbit times. Most importantly they are very safe technologies with a low risk of producing extra space debris.

### **Use and Testing**

An arcjet thruster will be used as the main propulsion on one of the baseline spacecraft to be used to transfer to the target altitude. When the spacecraft has docked, it will transfer it to an altitude of 300 km and the spacecraft.s AOCS will be used to perform a complete de-orbit. The first transfer phase will take 34 days and the second phase will take 100 days.

The arcjet propulsion system will be used to test the complexity of performing de-orbit scenarios using low thrust systems. The mission will also provide information as to whether it is possible to perform longer life missions such as multiple de-orbits.

### **C.3.5 Conclusion**

The electrodynamic tether was designed to be more effective in a high inclination. The tether length was decided to be 10 km long to increase the drag force produced and the tether configuration was decided to be a double line to increase its survival probability.

The arcjet did not display the reduced propellant mass expected. It was recognised that to benefit from this the arcjet would need to perform higher  $\Delta V$  . changes, possibly by carrying out missions using multiple de-orbits. The payloads satisfy the mission.s main requirements and were quite easily adaptable to the baseline spacecraft.

## C.4 Executive summary: DR.LEO, Baseline, Operations, and Software, Michael Demel

DR.LEO is a Phase-A study for a mission to actively remove space debris from Low Earth Orbit (LEO). It is undertaken as a Group Design Project by a team of 11 students of the MSc in Astronautics and Space Engineering course at Cranfield University. The project name, DR.LEO, is an acronym and stands for Debris Removal Low Earth Orbit.

The study is undertaken before the background of major debris related incidents in Low Earth Orbit (LEO) in only the last three years. It aims to dovetail into the variety of debris-related research efforts by combining the development of a complete mission baseline with the analysis of potential capture and de-orbit strategies of non-cooperative objects (“targets”).

The following sections detail the Baseline design process and target selection methodology, and provide an overview of the Operations, Software Architecture, and OBDH Work Packages.

### C.4.1 Baseline Design and Target Selection Methodology

Top-level mission requirements and constraints were presented by the customer. Important system-level issues that still had to be clarified concerned the definition of payload and the selection of targets. For the latter, an appropriate target selection process had to be chosen and justified. The removal strategy illustrated in Liou, Johnson and Hill (2010) was adopted as it included a target selection criterion “based on the mass and collision probability of each object.” In particular, Liou, Johnson and Hill (2010) state that by de-orbiting five debris objects (selected based on this particular selection criterion) per year, the cascading effect of debris in the LEO environment, known as the Kessler Syndrome, could eventually be stabilized.

With these factors in mind, a baseline design was developed as a first milestone of the project, trading off various different mission architectures and scenarios. During the second half of this project, the baseline design was developed into further detail, down to a sub-system level.

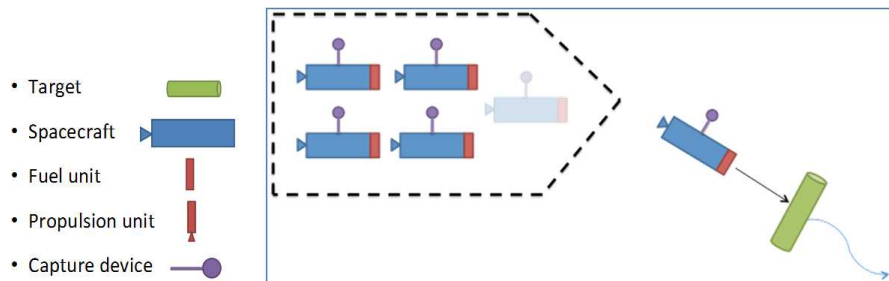

Figure C.3: Original Baseline Design

Figure C.3 shows the original baseline design in a very abstract manner. Five spacecraft are being stacked into a Soyuz Fregat launcher, to be launched from the European Space Agency’s launch complex in Kourou, French Guyana.

The payload was defined to be the capture device. In its final iteration, the payload was eventually split into two separate devices (Figure C.4):

- a capture device, consisting of a robotic arm with a grapple device mounted to its front, intended for initial target intercept and de-tumbling / de-spinning of the target
- A docking mechanism, intended to establish a firm connection between the chaser spacecraft and the target

The original concept of a propulsion unit was eventually abandoned; a fuel unit is simply a certain amount of fuel.

The five spacecraft or “chaser” received the internal designation YUKI 1-5.

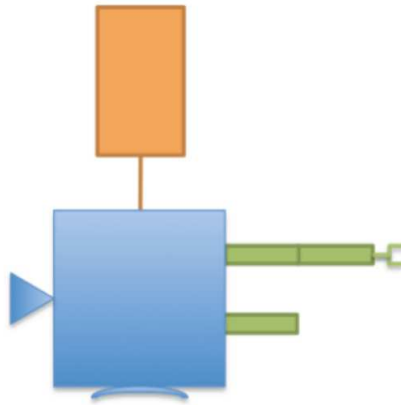

Figure C.4: YUKI chaser spacecraft (sketch by Grama, 2010)

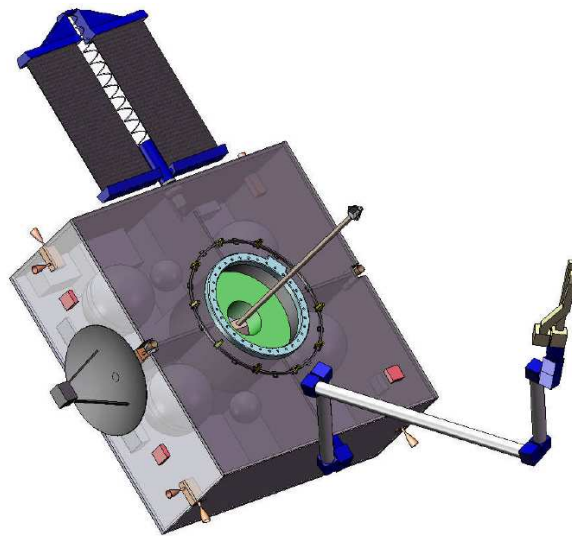

Figure C.5: YUKI chaser spacecraft (CAD drawing by Ratcliffe, 2010)

## C.4.2 Operations

The main objective of the Operations Work Package is the creation of a mission operations plan by integrating the details of the various functional areas of the DR.LEO project into a functioning system, so as to ensure successful and satisfactory mission operations without any technical conflicts among subsystem or between spacecraft bus and payload. The operations plan shall identify the different mission phases and the mission timeline (Figures C.6 and Table C.6). Design drivers for Operations were derived from top-level requirements and constraints to be Maximum Autonomy (autonomous spacecraft operations) and High Reliability.

It should be noted that three of the five YUKI chasers use conventional chemical propulsion methods for orbit manoeuvring. As per top-level mission requirement, the two remaining chaser have alternative propulsion technologies implemented for trial purposes, namely an electro-dynamic tether and an electric propulsion engine.

## C.4.3 Software Architecture and OBDH

The main objectives of the Software Architecture Work Package were the development of operational spacecraft modes and anomaly modes (Figure C.7), a preliminary estimate of the required data throughput and thus and estimate for the required onboard processing power. This in turn allowed for an estimate of the necessary onboard C&DH requirements.

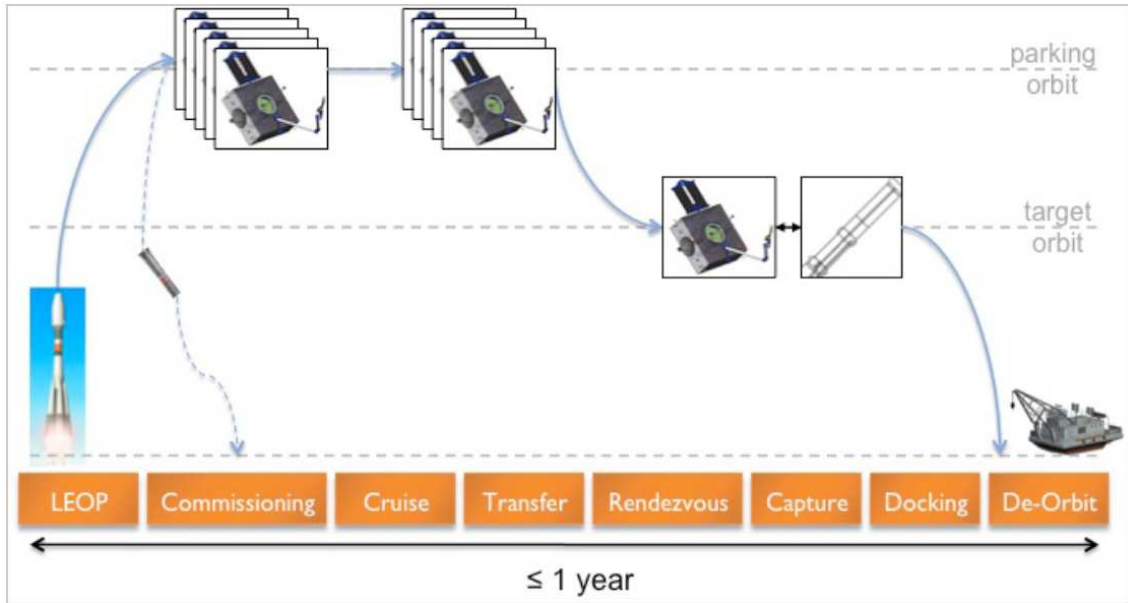

Figure C.6: DR LEO mission phases

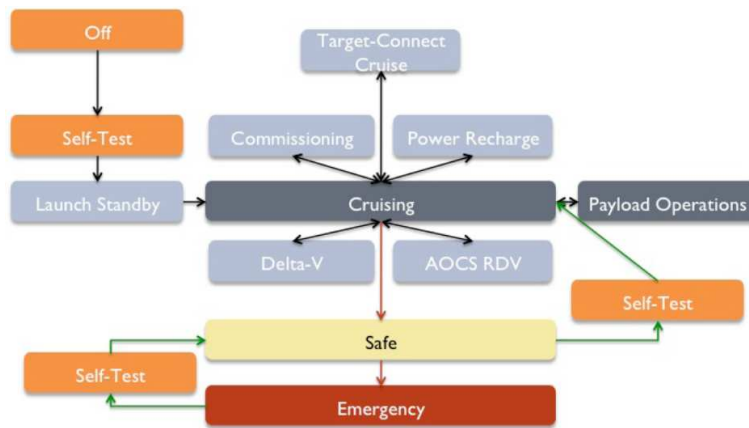

Figure C.7: YUKI State Transition Diagram

Key driving requirements for the design of the Software Architecture and the OBDH system could be directly take from top-level mission requirements and constraints but were also influenced by other Work Packages, in particular Operations. They were identified as:

- High Reliability
- Redundancy
- High Processing Power
- Modularity



Table C.6: DR LEO mission operations timelines for each of the five “Yuki” chaser spacecraft.

Yuki	1	2	3	4	5
Transfer technology	electric	chemical for Yuki 2–5			
De-orbit technology	electric & chemical	tether & chemical	only chemical for Yuki 3–5		
Launch date	28 Feb 2015 in all cases				
LEOP	< 1 day in all cases				
Commissioning	7 days in all cases				
Cruise	182 days	45 hr	273 days	324 days	327 days
Transfer	34 days	50 min for Yuki 2–5			
Rendezvous	6 hr in all cases				
Capture	1 hr in all cases				
Docking	1 hr in all cases				
De-orbit	100 day + 70 min	331 day + 65 min	65 min for Yuki 3–5		
Mission end	18 Jan 2016	4 Feb 2016	6 Dec 2015	26 Jan 2016	29 Jan 2016

## C.5 Executive summary: DR.LEO, Budgets, Rushi Ghada- wala

### C.5.1 Delta-V budget for mission baseline concepts

Table C.7:  $\Delta V$  budget for each concept

Concept	Total $\Delta V$ (m/s)	Total Mission Time (days)
1.a, 1.b.2, 1.c	4145	336
1.b.1	5195	336
2.a.1, 2.a.2.2	2770	336
2.a.2.1	3619	336
2.b	840	70

### C.5.2 Trade-off studies for Mission concepts

Table C.8: Mission concept trade-off

Weight	Mission Duration	Mass	Construction Cost	Simplicity	Mission Reliability	Total	Match requirements
	30%	25%	20%	15%	10%		
1.a	2	3	3	3	3	32	Yes
1.b.1	2	1	2	1	1	18	No
1.b.2	1	2	1	2	1	17	Yes
1.c	3	2	2	1	2	27	Yes
2.a.1	4	4	4	4	4	48	Yes
2.a.2.1	2	2	2	3	1	24	Yes
2.a.2.2	3	3	2	1	2	32	Yes
2.b	5	4	5	4	3	53	No

### C.5.3 Antenna Specifications

Table C.9: Antenna Specifications

Dish Diameter	0.75m
Height (Parabolic Depth)	0.09m
Height of horn from Dish	0.3943m
Horn size	0.13 x 0.13m
No. of struts to the dish	2 (1 + 1: side attachment)
Antenna Mass	3.618125kg

### C.5.4 Link Budget Analysis

Table C.10: Link budget summary

Tx power /dBW	EIRP/ dBW	Data rate / Mbps
-8.83	-5.78212	4.50
-8.37	-5.32454	5.00
-7.96	-4.91062	5.50
-7.58	-4.53273	6.00
-7.24	-4.18511	6.50
-6.91	-3.86326	7.00
-6.61	-3.56363	7.50
-6.33	-3.28334	8.00

## C.6 Executive summary: DR.LEO, Mechanisms, Vinay Grama

DR. LEO (Debris Removal Low Earth Orbit) is a project which examines the possible methods and technologies to dock and de-orbit large space debris. The selected targets are five Ariane 40 H-10 upper stages.

The report covers work done in the mechanisms work package of the DR LEO group design project. The entire mechanisms work package is subdivided into four main mechanisms.

- Docking mechanism
- Launch adapters
- Solar array deployment mechanism
- Antenna deployment mechanism

### C.6.1 Docking mechanism

The docking mechanism is conceptual, based on on-going industrial research and utilizes existing COTS components. It is based on the concept of the small apogee motor insert from DLR (German Aerospace Centre).

#### Requirements

1. It should dock with the target (Ariane 40 Upper stage nozzle).
2. It should constrain the target with the spacecraft in all degrees of freedom.
3. It should sustain the docking during the de-orbit burn.
4. It should be compact in size.

The docking mechanism consists of three parts:-

- Nozzle Insert
- Linear deployment device
- Docking ring

**Nozzle insert** This docks into the throat of the targets nozzle and locks it with respect to the spacecraft axially. The nozzle insert is similar to a torsion-spring loaded grapple hook. It has three projecting levers actuated by two torsion springs at each pivot point readily available as they are used in solar panel deployment hinges.

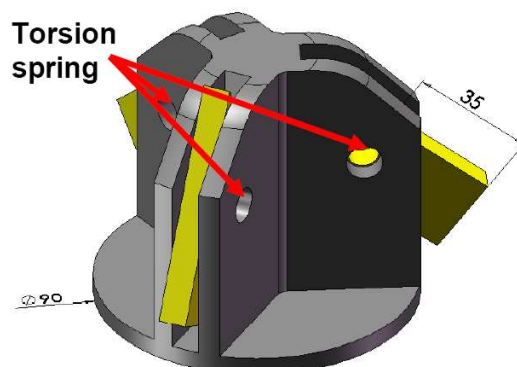

Figure C.8: Nozzle insert (dimensions in mm)

**Linear deployment device:** After a trade off, the linear deployment device selected is the Tubular boom STEM<sup>TM</sup>. These are extendable booms which are stored flat on reels and get their stiffness during deployment when they undergo transition from a flat to a curved geometry.

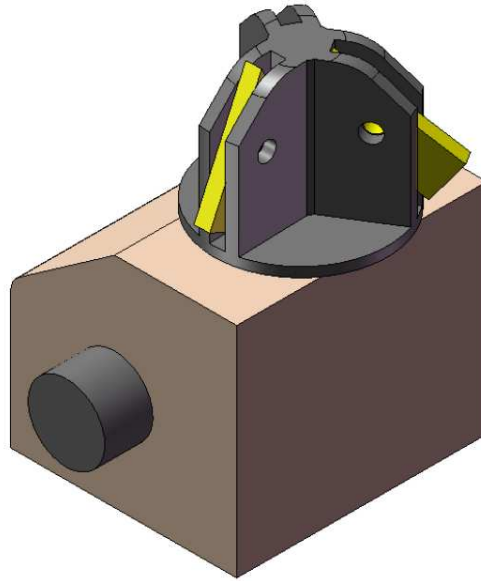

Figure C.9: Linear deployment device with nozzle insert

**Docking ring:** Since the spacecraft and target are spin stabilised during the de-orbit burn, the main requirement of the docking ring is that it has to constrain the spacecraft and target with respect to torsion. The docking ring also aligns and constrains the target and the spacecraft radially. The actuator for the gripper fingers was derived from Starsys<sup>TM</sup> AH-9060 powered deployment hinges. Alternative actuators such as hinge torsion springs or Shape Memory Alloys (SMA) could be used. Two versions of the docking ring are presented.

- Version 1: This version is capable of docking on to a nozzle with no distortion. It has 5 pairs of grippers with another 5 pairs for redundancy.
- Version 2: This version is capable of docking onto a nozzle with a maximum radial distortion of  $\pm 75$  mm. A minimum of three fixed points are required to align the nozzle with the spacecraft axially. This docking ring has three fixed grippers and three radially movable grippers held by compression springs.

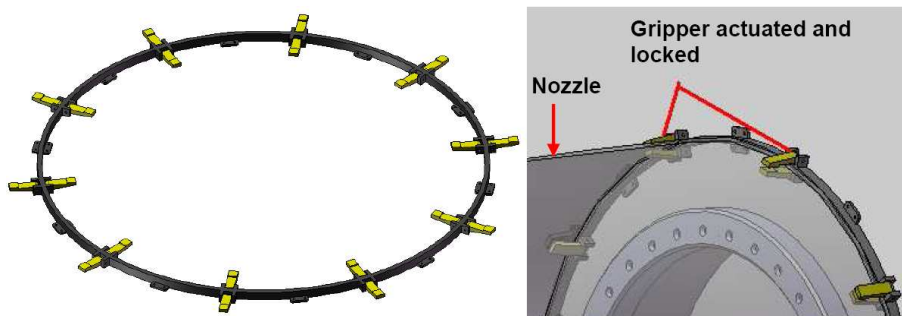

Figure C.10: Version 1 docking ring

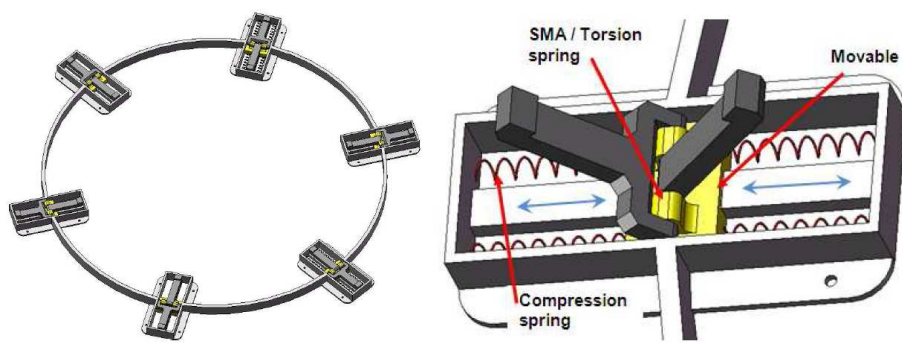

Figure C.11: Version 2 docking ring

### C.6.2 Launch adapter

The launch adapter section is sub-divided into two types of adapters:

- Main Interface Launch Adapter (MILA): As the name indicates, this is the main interface adapter between the spacecraft stack to the COTS launch adapter.
- Inter Spacecraft Adapter (ISA): This is the adapter which is located between each spacecraft in the stack.

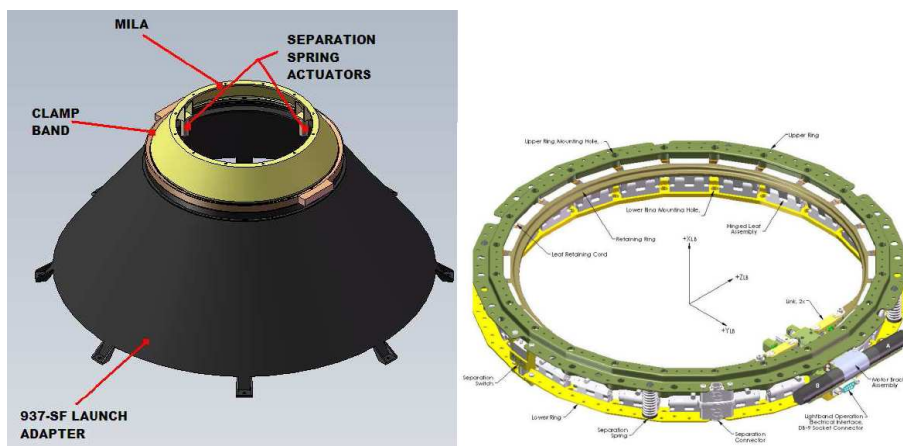

Figure C.12: MILA and ISA

### C.6.3 Solar array deployment mechanism

An area of 5.3 m<sup>2</sup> is required for the spacecrafts using chemical propulsion and an area 13.3 m<sup>2</sup> is required for the spacecraft using electric propulsion. Since the maximum area available on the spacecraft is 1.8 m<sup>2</sup> the solar arrays cannot be body mounted and a deployment mechanism is required. A main engine burn is required for a Hohmann transfer from the parking orbit to the target and for de-orbiting the target. Hence, the solar arrays have to be retractable. After a trade off the flexible thin film solar arrays with a coil mast boom deployment mechanism is selected. The mass for the 5.3 m<sup>2</sup> array assembly is 30.2 kg and for the 13.3 m<sup>2</sup> array assembly is 68.2 kg.

### C.6.4 Antenna deployment mechanism

The Antenna on the DR LEO spacecraft is a parabolic dish High gain antenna (HGA) having a diameter of 750 mm. It is deployed by 90° and has bi-axis gimbal providing ±90° tracking in each

axis. The antenna deployment mechanism is required only for the DR LEO spacecraft with electric propulsion.

### **C.6.5 Conclusion**

The active removal of space debris is essential and vital to future missions and the sustainability of space. It is highly challenging to docking on to intact space debris mainly dead satellites and upper stages of rockets. Compared to the basic design of the solar array deployment mechanism, launch adapter and the antenna deployment and pointing mechanism which are fairly standard, the design of a docking mechanism which can dock onto intact debris is challenging since it has never been done before. The design presented provides a good baseline for future work on technologies suited for active removal of space debris.

## C.7 Executive Summary: DR.LEO, Launch and propulsion, Guillaume Mathon-Margueritte

The mission's goal is to actively remove five large objects from LEO. To achieve this goal five independent S/C will be launched in one launcher and each will de-orbit one Ariane 4 upper stage.

The aim of this study was the selection of a suitable launch vehicle and, sizing and design of the chemical propulsion system for the DR.LEO.

### C.7.1 Launch

The selection of a suitable launch vehicle is crucial for the mission. It was also one of the earliest decisions made in order to start the design of the spacecraft.

From the mission objectives and consideration of systems requirements some particular drivers can be derived from the other work packages and the mission requirements.

#### Drivers

In order to choose the best launch vehicle for our mission, we need to consider all the inputs from the other WP as well as the mission requirements.

First the orbit the S/C is a circular orbit with an altitude of 1200km and an inclination of 98°. Then during the first study, the mass of one S/C was about 700 kg. Therefore the launch vehicle has to put approximately 3.5 tons into this orbit in one year.

For this debris removal mission another important requirement is not to release debris: this requirement is also applied to the launch vehicle selection.

Cost is the most important driver because a lot of launch vehicles have the capability to launch a payload of about 700 kg into low earth orbit with a high inclination (and some are able to launch the 4 t of the baseline into this same orbit). Therefore an important criterion for the trade study will be the cost and moreover the launch cost per target de-orbited.

#### Selection

Although it is required for the mission to use European technology, the selection of launch vehicle has been extended to Russian vehicles. We have separated this study into three main categories: small, medium, and heavy launch vehicles. The Table below summarize their characteristics:

Table C.11: Launch vehicle selection (Isakowitz, Hopkins and Hopkins, 2004)

Launcher	SMALL		MEDIUM	HEAVY	
	VEGA	ROCKOT	SOYOUZ (2-1b)	ARIANE 5	PROTON
Country	Europe	Russia	Russia	Europe	Russia
Capability / tonne	~1.1	~1.0	~4	>10	>10
Cost / M\$	20	12-15	30-50	125-155	100-112
Nb of S/C	1	1	5	~2x4	~7
Cost/Target M\$	20	12-15	6-10	~15.5-19.5	~14-16
Other	Need multiple launch per year		Launch from Kourou Fregat upper stage Arianespace	Arianespace	

From this information the Soyouz 2-1b has been selected. It has the required performance to launch a stack of five independent S/C, which is our baseline concept in one launch. Moreover it will soon be launched from French Guiana and operate by Arianespace which has operated the Ariane 4 (our target).

Beside the Fregat upper stage has the capability to de-orbit itself and therefore we meet the mission requirement of not releasing space debris.

The Soyouz vehicle has above all the smallest launch cost per target de-orbited. It is one of the main reasons for its choice as first launch vehicle.



Ariane 5 has also been chosen as a backup launcher because we can fit inside its fairing 2 times four S/C and (maybe five) and therefore it can be used with only few modifications of our S/C.

## C.7.2 Propulsion

The use of chemical propulsion in order to de-orbit the targets is one of the mission requirements. Consequently the choice and the sizing of the propulsion system is critical for the project. The main inputs for this system are the  $\Delta V$ , the dry mass of each S/C and their configuration. And the outputs will be the propellant mass and the size of the components

The chemical propulsion is used on each spacecraft for different manoeuvres. Concerning the last one (de-orbit burn) it has to be the quickest as possible in order to control the entry but we also need to consider the other requirements.

To keep the cost as low as possible we will chose components which need the less developments as possible and when it is possible we will chose components which are already been developed and off the shelf. We need to take into account also the Ariane 4 rocket body mass (assume to be 1600 kg) for the de-orbit burn.

### Engine selection

We can now perform a further study following Wertz and Larson (1999) for the options of the propulsion system. We have three candidates to study. The first one is a simple monopropellant hydrazine system. The two others are bipropellant systems. But for these ones we can consider a “classical” bipropellant system with MMH (MonoMethylHydrazine) and N2O4 as propellant or a dual mode system with Hydrazine and N2O4 as propellant.

The monopropellant thrusters have less performance ( $I_{sp} \sim 200s$ ) than the bipropellant thrusters ( $I_{sp} \sim 300s$ ). The difference of propellant mass is consequently too high and we can't have this mass of propellant. Therefore we don't chose the hydrazine engines. The main advantage of MMH-N2O4 thrusters is the tank volume of the oxidizer and the fuel is the same when we need six tanks with dual mode engines to have the same advantage. Since the configuration work package has chosen a cubic shape for the design of the S/C consequently we chose to have a bipropellant thruster (MMH-N2O4).

A research has been done on already available engines and the S400-12 engine from Astrium has been selected because of its performances ( $I_{sp} = 312 s$ , Thrust = 420 N) but also because of its short nozzle which is helpful for the configuration.

### Propellant Calculation

The propellant mass is calculated for each S/C with the help of the Tsiolkovsky's equation C.1. Table C.12 summarizes this calculation for the S/C with the EDT (mdry = 504 kg) with the  $\Delta V$  given by the orbit work package (Naicker, 2010)

$$m_p = m_f \left[ e^{\Delta V / I_{sp} g} - 1 \right] = m_0 \left[ 1 - e^{-\Delta V / I_{sp} g} \right] \quad (C.1)$$

Table C.12: Propellant calculation and key results (based on Wertz and Larson, 1999)

Task	$\Delta V$ (m/s)	mf (kg)	mp (kg)	Margins (+15%) (kg)	Residuals (+2%) (kg)	tb (min)
de-orbit	210	2086	145	167	170	20.7
Circularization	102	631	21	24	25	3.0
H. First Manoeuvre	101	507	21	25	25	3.1
Inclination	38.8	499	8	10	10	1.2
TOTAL			196	226	230	28

### Other components sizing

The other components of the propulsion system has been sized and the main characteristics are summarized in the figure

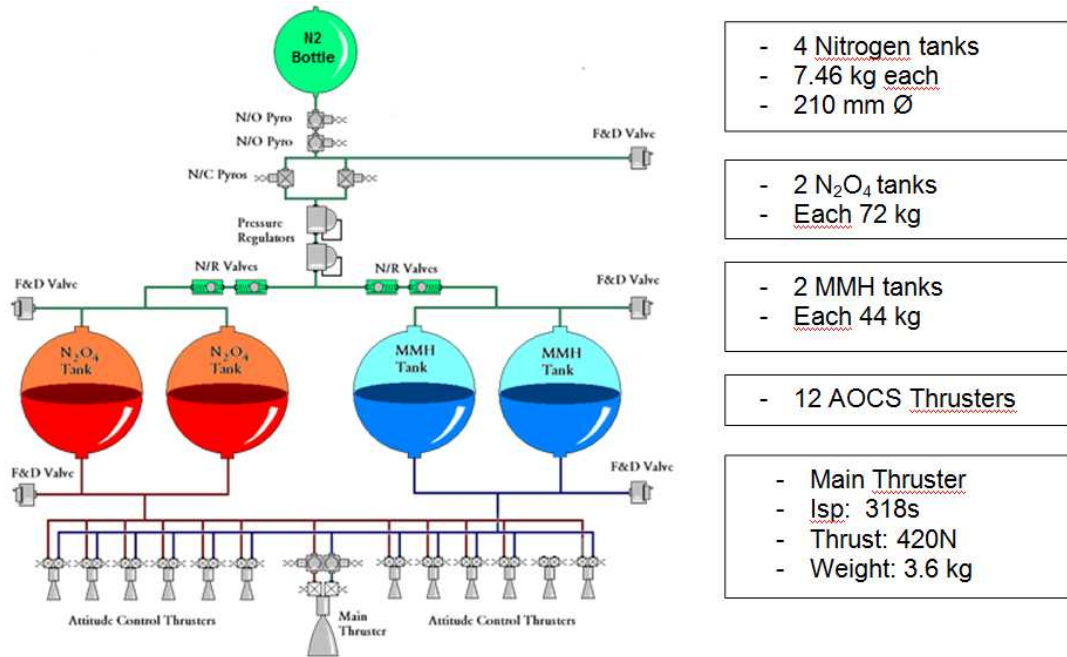

Figure C.13: Propulsion system

## C.8 Executive summary: DR.LEO, Lolan Naicker

### C.8.1 Background

A population cascade effect has been predicted for man-made debris in low earth orbit. It has been estimated that to stabilised the population, at least five large pieces of space debris should be removed per year. Cranfield University has undertaken a study to estimate the mass specific cost to de-orbit space debris in low earth orbit. This is a step towards quantifying, in monetary terms, the extent of the problem in the near space environment.

The study has focused on tumbling Ariane 40 rocket bodies in the highly populated near-polar orbit environment. The baseline mission involves one interceptor spacecraft per target object using chemical propulsion for intercept and de-orbit. The interceptor spacecraft design is then applied to targets of different configuration and in different orbits to determine necessary design modifications and quantify implications on mission cost.

The first estimate of *cost/kg-debris* to actively de-orbit low earth orbit debris is approximately €30 000 (FY 2010)/kg-debris and it emphasises the need to consider the full life cycle of space projects as well as the benefit of budgeting for end-of-life strategies early in the mission design process.

### C.8.2 Overview

This work package within the mission subsystem covers orbit related aspects of such a mission and details the strategy that will allow these targets to be intercepted at minimum cost and de-orbited safely.

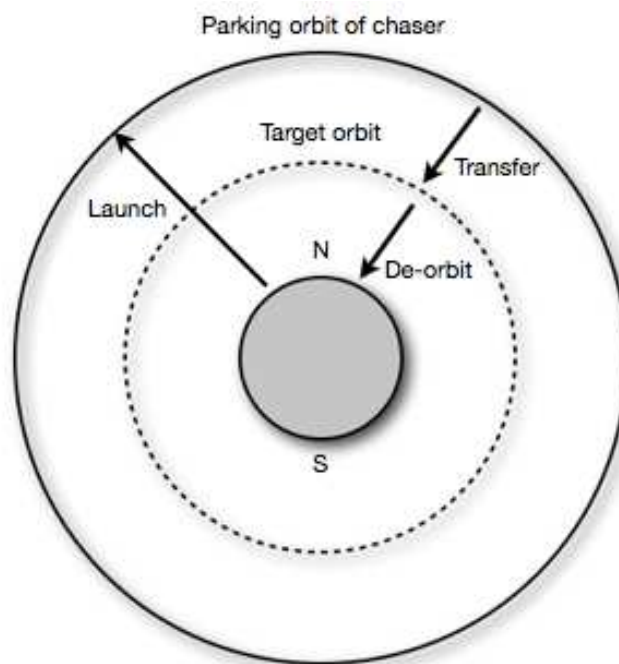

Figure C.14: Overview of the orbits used showing launch to the chaser parking orbit, transfer to the target orbit, de-orbit from the target orbit. Note that orbits are near-polar in inclination.

It is separated into three four stages that occur across the life of the mission

- Launch into low earth orbit
- Transfer to the target orbit

- Orbit phasing
- De-orbit of target to a safe location

### C.8.3 Analysis

The orbit strategy is a simple yet innovative one that utilises the J2 perturbation to reduce the  $\Delta V$  required to reach all five targets. This innovation takes the form of a so called *parking orbit* which has been optimised to allow the mission to satisfy the single year duration directed requirement.

The behaviour of the target orbits in relation to this parking orbit has been studied and this provides dates for de-orbiting.

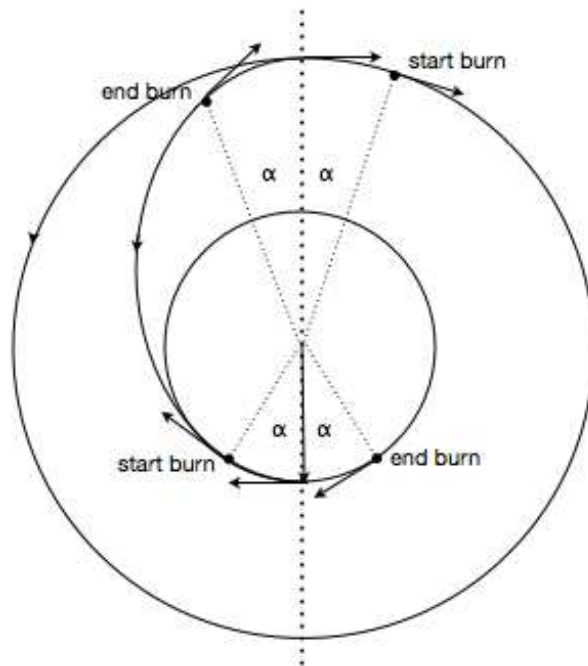

Figure C.15: Chemical Transfer : Finite burns centred at apogee and perigee, and characterised by the thrust arc  $\alpha$ , are used for the initiation of transfer from parking orbit altitude and circularisation at the target orbit altitude.

The trajectory of the five chasers between the parking orbit and target orbit below it has been studied and this provides an estimate of the  $\Delta V$  necessary to intercept the targets. Finite burn calculations have been performed for both chemical and electric main engines. These calculations provide accurate information on the manoeuvres expected of the chaser for the transfer and on state of the orbit once such manoeuvres are completed given certain proximity requirements.

A study of orbits created by the alternative de-orbit technologies (electric propulsion and tether) was performed. This provided information on the state of the coupled chaser through the testing phase of these technologies. The study also revealed challenges with the use of such low-thrust technologies for the purposes of de-orbiting debris in a controlled manner for targeted reentry.

The fate of the coupled chaser and target upon reentry was assessed. De-orbit policies were considered, a splashdown site was selected, estimates for impact footprint were made.

The local space environment was studied i.e. radiation dose to the chaser over the south Atlantic anomaly and eclipse estimates for the duration of the mission. The impact of both of these on the mission design was explored showing how such calculations could have far reaching design implications.

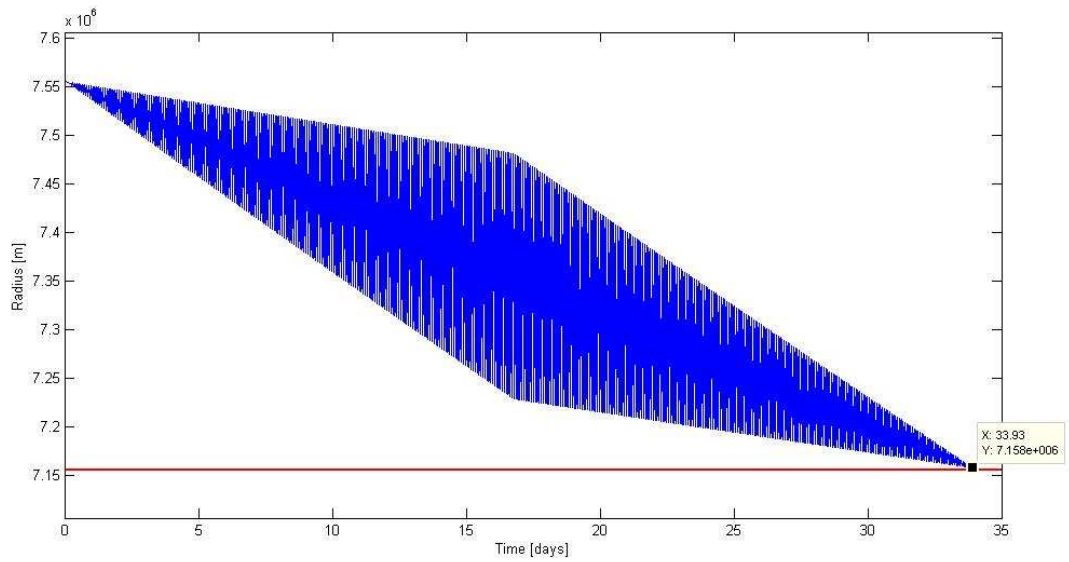

Figure C.16: Electric Transfer : Radial position over time for tangential continuous thrusting followed by perigee thrusting. Solid line at target altitude.

## C.9 Executive Summary: DR.LEO: Robotic Arm Design, Samuel PIN

The robotic arm designed for the mission concept DR.LEO is different from other robotic manipulators. It can be seen more like an articulated damper. The arm is a common aspect for all five spacecraft launched to de-orbit five Ariane 4 upper stages within one year. It has been designed to capture the target and damp its motion in order to allow for docking.

### C.9.1 First shaping

A first calculation showed the need to have a degree of freedom between the tumbling target and the spacecraft. As there is a high-force contact between the chaser payload and the target, a degree of freedom is required to alleviate it. The problem of the high moment of momentum is not solved in that case. That is the reason why it is necessary to have the degrees of freedom damped.

#### Degrees of freedom

The arm has 6 degrees of freedom linked by 3 rods leading at an end-effector at the extremity as shown in Figures C.17 and C.18.



Figure C.17: Arm deployment.

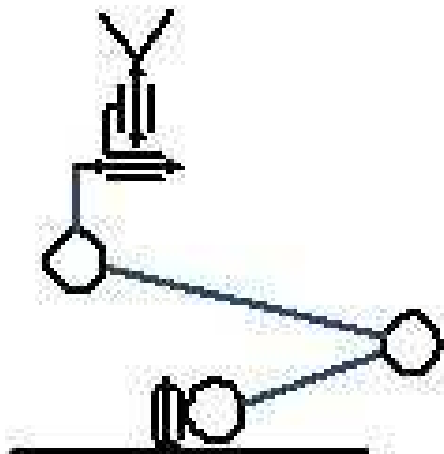

Figure C.18: Arm kinematic diagram.

With those degrees of freedom, the arm is deployed within one plane at the beginning by actuating the 3 first joints, and then the others are used to aim the target and also to handle it after stabilization.

## Links length

The arm has to keep the spacecraft away from the tumbling upper stage during the critical stabilization phase. A minimal length of 3 m is required in case of a capture at the nozzle throat (our worst case).

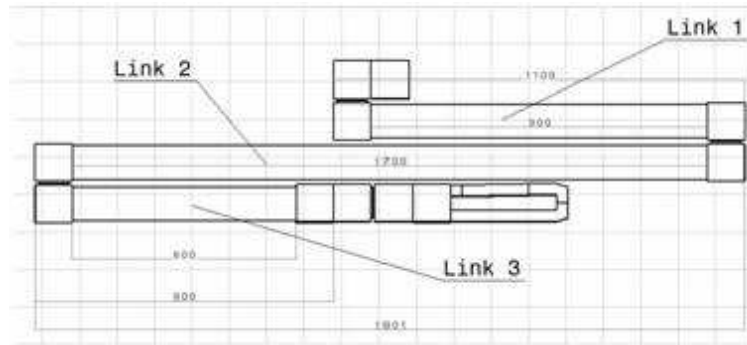

Figure C.19: Arm face view and main dimensions

## Tubes thickness

The thickness driver is mainly the maximal stress or strain equal to  $2 \times 10^{-4}$  m. By utilising Matlab, two curves showing the variations of the outer radius and the mass with respect to the thickness are obtained. A thickness balancing the mass and radius requirements was chosen.

Design thickness	5 mm
Outer radius	5 cm

## C.9.2 Sizing iterations

### Simulink

The calculation with translation of moments of inertia gave the same maximal torque as obtained during the first approach, even if the global behaviour was not the same (alignment of the bodies at the stable state because of the rotation producing centrifugal forces).

### 5 bodies

The damping is assured by the 4 joints. The moment seen before is thus spread between these 4 dampers. The maximum torque occurs at the joint closest to the target and is equal to 85 Nm. As the others are put in motion later, their resultant torque is lower and increases from zero before balancing the first one (see Figure C.20).

### ADAMS validation

The validation model gave some results (Figure C.21) close to the previous ones where the approximation not to translate the moments of inertia was taken.

## C.9.3 Mechanisms selection

### Actuators and dampers

While selecting the mechanisms, many constraints were imposed, such as the constraint to only use components of European origin. The selected actuator is a DC motor from RUAG Aerospace named the Scalable Rotary Actuator (3.5 kg). For the damping, due to the high ratio required, an Eddy Current Damper (1 kg) has been chosen. It is to be mounted on the output shaft of the SRA in the same joint.

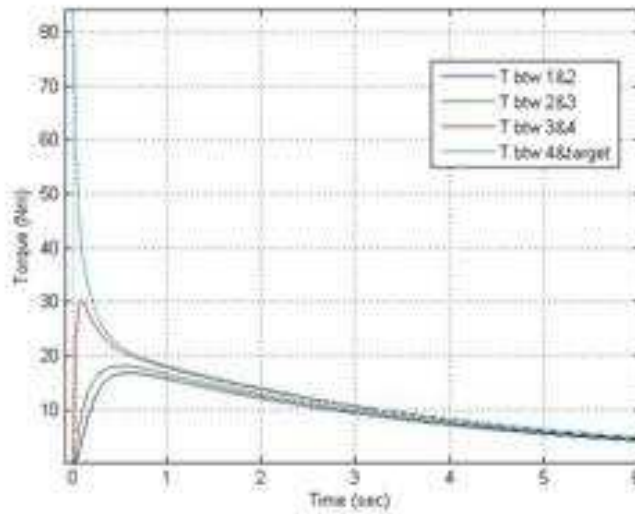

Figure C.20: Damping torques - third calculation

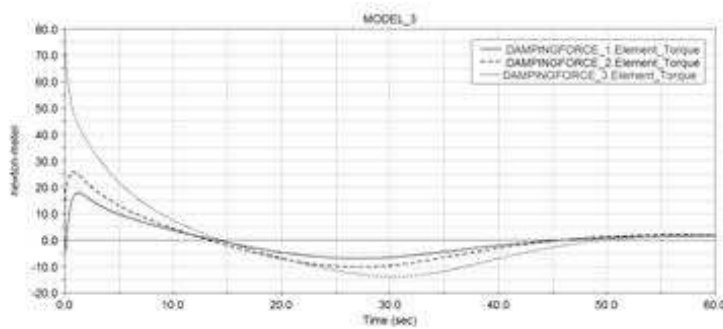

Figure C.21: ADAMS torque results

### End-effector

The end-effector is a clamp using the same high torque DC motor than in the joints. It has been designed for grasping the edge of the nozzle and not at the throat, as first thought at the beginning. The final ADAMS simulation where the contact forces are taken into account shows that even if the target velocity is too high to allow the clamp to hold the nozzle all the time, the kinetic energy of the target is largely absorbed. The stabilization could be made within 2 attempts. With the end effector the arm weighs a total of 58 kg with margin.

### C.9.4 Conclusion

To sum up, the design of the arm encountered some obstacles. However, the result is positive and even if it is only a preliminary design, capturing and damping the motion of an Ariane 4 upper stage appears feasible. Nevertheless, a discussion on the requirements and constraints would be useful, like for the target tumbling rate which was a key driver for almost the whole sizing process. Finally, the system loses some reliability due to the number of joints with no possible redundancy. It is a common issue when articulated manipulators are used in space, and what this robotic arm could achieve would be satisfactory.





Figure C.22: The SRA (left) and the ECD (right)

## C.10 Executive Summary: DR.LEO, Structure, Sandrine Quevreur

The aim of the project is to de-orbit at least five large pieces of debris from LEO within a year. The items should be burnt by re-entry into Earth's atmosphere. The de-orbit phase is achieved with chemical propulsion, but the mission should demonstrate at least two other disposal technologies.

In a structural point of view, the winning concept is five spacecraft in a stack configuration. The spacecraft are all identical to the lowest spacecraft which withstands the most critical loads.

During the design, the stiffness, the strength and the mass are all investigated.

### C.10.1 Initial sizing

The required stiffness was first calculated by using a system of five mass-springs modelling the stack. An individual spacecraft was then sized for strength and rigidity.

A cantilevered hollow cylinder model with an equivalent distributed mass was used to estimate the minimal thickness of the structure, the mass budget and the materials (Wertz and Larson, 1999). A case study was performed and led to the need of a further sizing.

Table C.13: Initial sizing - results

Material	Aluminium	Titanium	Magnesium
Minimal thickness (mm)	6	4	9.4
Margin of Safety	3.5	1.8	6.8
Mass (kg)	29.6	31.4	29.6

### C.10.2 Detailed sizing

Once a steady configuration released, a more detailed sizing could be performed.

#### Configuration

The spacecraft structure can be split in three different categories:

- The primary structure: it is the backbone of the spacecraft.
- The secondary structure: payload, antenna, tanks, booms, main equipment...
- The tertiary structure: boxes, pipes, small components...

The primary structure should be sized to withstand the launch loads. The secondary and tertiary structures, lighter, are sensitive to the vibrations and shocks. This sizing is focused on the primary structure. The primary structure can be split in three different subsystems:

- The central cylinder, which carries the loads due to the upper spacecraft.
- The outer and end panels, on which are mounted most of the components and especially the payload.
- The shear panels, which provide a loads path between the outer panels and the central cylinder.

#### Cylinder

The mass design criterion led to consider another solution for the cylinder. A strength analysis was performed again for two new options:

- A cylinder built with a laminate

- A cylinder built with a sandwich construction.

Multiple combinations were studied: number of plies, type of material for the sandwich's skin. The sandwich construction was the successful candidate. The mounting of the fuel tanks, which are the heaviest secondary structure, was investigated. The final result is summarized in the

Skin	Material	Laminate: 24 plies, UD Carbon/Epoxy
	Thickness	2 mm
	Density	1500 kg m <sup>-3</sup>
Core	Material	Honeycomb "Flexcore"
	Thickness	20 mm
	Density	65.7 kg m <sup>-3</sup>

Table C.14: Cylinder - final selection

### Panels

If the cylinder is the backbone of the primary structure, the panel are still subjected to several loads. The effect of the loads introduced by all the components and the effect of the mounting of the heaviest components were studied to size the panel.

An equivalent distributed load modelling the mounted equipment was applied at the edges of the panels and the buckling studied.

From this first result, a stress analysis by using the software Patran/Nastran was performed and led to the temporary selection of a sandwich Al/Al material.

### Frequency analysis

As the strength requirement was met, the stiffness requirement still needed to be studied. For this step, the frequencies analysis of the whole spacecraft was performed with Nastran. Three configurations were evaluated in order to progressively eliminate some materials and to take a grip on this tool:

- The spacecraft.
- The spacecraft + the solar panel mounted on an outer panel.
- The spacecraft + the solar panel mounted on an outer panel + the fuel tanks mounted on the cylinder.

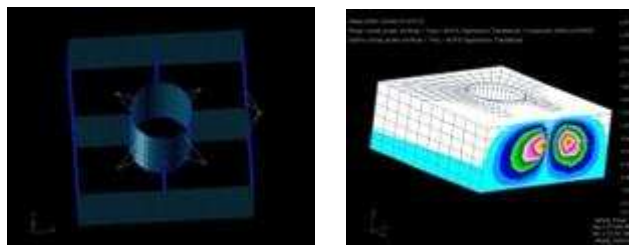

Figure C.23: Primary structure + solar panel + tanks - Patran model and normal modes

From the analysis of the modes, it appeared that the global structure was very stiff but the solar panel was vibrating first for low frequencies and then the tanks.

The final material selection was a sandwich construction with two possible options:

- An aluminium honeycomb core and an aluminium skin.
- An aluminium honeycomb core and a composite skin.

Skin - option 1	Material	Laminate: 8 plies, UD Carbon/Epoxy
	Thickness	1 mm
	Density	1500 kg m <sup>-3</sup>
Skin - option 2	Material	Aluminium alloy
	Thickness	0.5 mm
	Density	2800 kg m <sup>-3</sup>
Core	Material	Honeycomb "Flexcore"
	Thickness	20 mm
	Density	65.7 kg m <sup>-3</sup>

Table C.15: Panels - final selection

### C.10.3 Conclusion

The final configuration met the strength and stiffness requirements for a minimized mass. The main aims of the mission concerning the structure have been fulfilled. The feasibility of the stack configuration has been demonstrated and the first design achieved. The current design is not yet optimized, but a good baseline has been established.

A preliminary design provided some inputs for the mass budget and gave a first estimation of the design. The further design included the work of the other work packages, especially from the mechanical sub-systems to provide a baseline meeting the requirements.

Assumptions and simplifications had to be made, and some aspects ignored at this level. For future work, a new iteration with more accurate loads and a more detailed model should be performed. It would be useful to investigate the mounting of all the equipment and also to consider the assembly of the different parts.

### C.10.4 Key references

Kollar, L. P. and Springer, G. S. (2003), *Mechanics of composite structures*, Cambridge University Press, Cambridge.

Sarafin, T. P. and Larson, W. J. (1995), *Spacecraft structures and mechanisms - from concept to launch*, Microcosm, Torrance, Calif.

Wertz, J. R. and Larson, W. J. (1999), *Space mission analysis and design*, 3rd ed, Microcosm ; Dordrecht; Kluwer Academic, Torrance, Calif.; London.

Wijker, J. J. (2008), *Spacecraft structures*, Springer, Berlin.

## C.11 Executive summary: DR.LEO, Configuration, Andrew Ratcliffe

Recent projections of the long-term Low Earth Orbit (LEO) space debris environment indicate that even if there are no more launches, the debris population will continue to increase (Klinkrad and Johnson, 2009). Events such as the Iridium-Cosmos collision in February 2009 have alerted government and industry partners to the need for immediate action to mitigate the amount of debris in LEO. A number of studies are now being performed globally to design a feasible and cost effective solution to removing debris from LEO. The majority of studies focus on the removal of large mass items from orbit as these represent mass reservoirs that in the event of a collision would release a large array of particles into the environment. Noticing the criticality for removal of large mass items from LEO, the DR.LEO team has developed a baseline for the removal of 5 Ariane 40 Upper Stages from orbit per year.

Although Active Debris Removal is plagued by technical issues there are many political and legal issues which must be solved before any mission can be launched. The primary concern for governments and operators is that any system capable of capturing and de-orbiting an un-cooperative non-operational target is also capable of removing an active operational satellite from orbit. To alleviate these concerns the present study has focused on both the technical issues and the less obvious political and legal issues surrounding the debris problem

The baseline design adopted by the group was for a single rendezvous and return vehicle. The mission will consist of 5 identical chasers launched into a parking orbit which then sequentially target specific large mass items at the same inclination. The design of the chaser vehicle can be seen in Figure C.24.

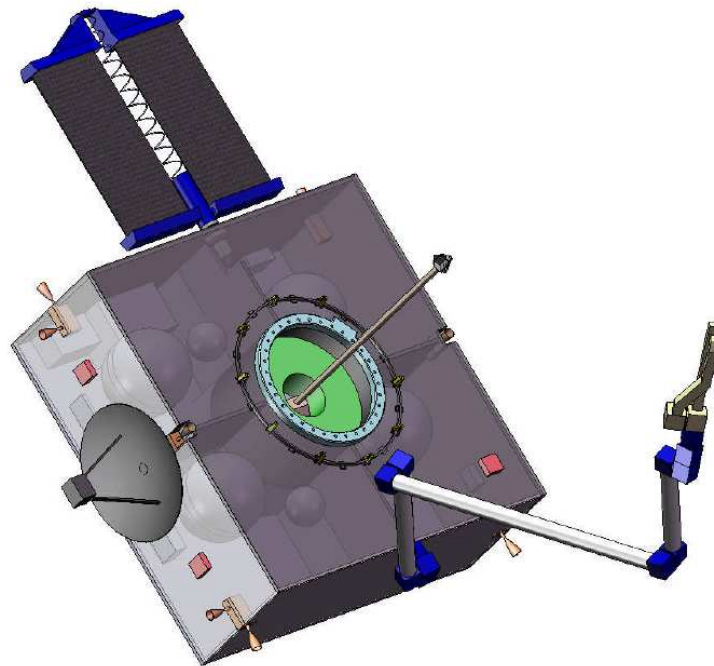

Figure C.24: Standard Chaser Spacecraft

The spacecraft will be launched on a Soyuz from Kourou, French Guiana. The key to stabilising the LEO debris environment is a continual mitigation strategy i.e. the removal operations must occur yearly. A reduction in the number of objects removed will limit the effectiveness of the ADR. As such the Ariane 5 is chosen as the back-up launcher in-case there are supply problems with the Soyuz, see Figure C.25 for launch configurations.

Although there is a mass penalty associated with an identical spacecraft stack design, the design was considered a more robust option than the other concepts considered. The primary mechanism for de-orbit is chemical propulsion. Within each spacecraft a large bi-propellant engine

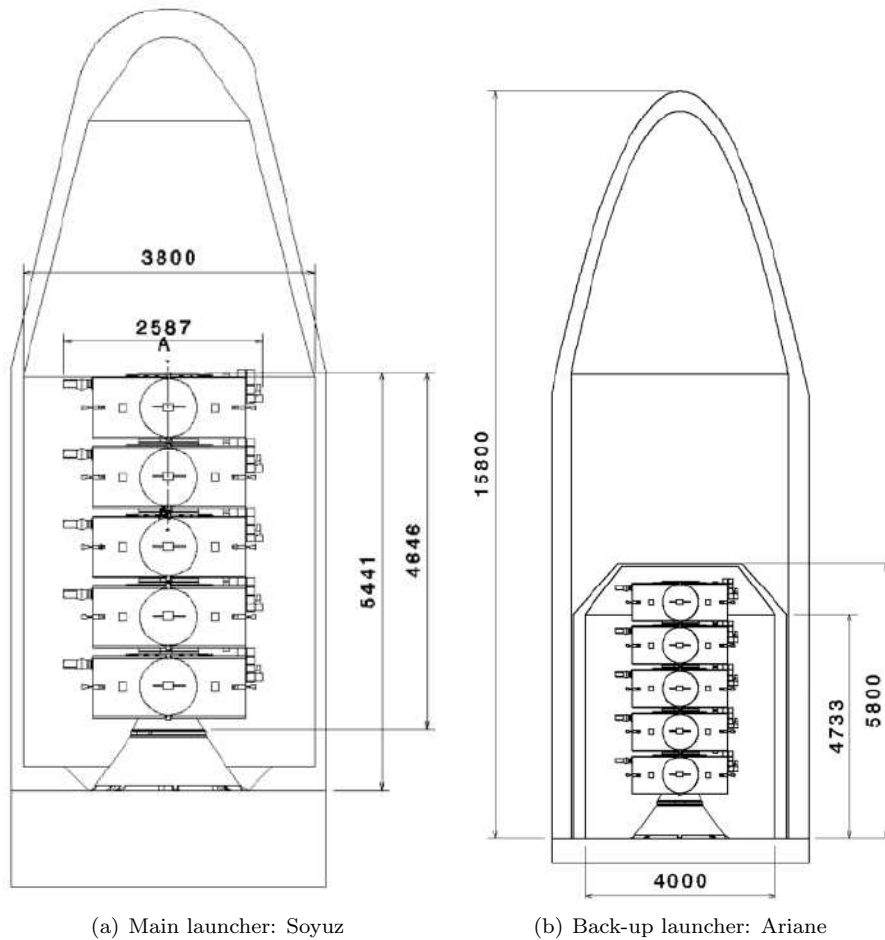

Figure C.25: Launch configurations of the chaser spacecraft

was required. In order to avoid difficulties with heat transfer, as much nozzle as was feasible was configured to be outside the spacecraft, the resulting configuration in a stack can be seen in Figure C.26.

Although the nozzle proportion outside the spacecraft is increased, consideration must be made of the tip off rate and angle developed by the inter-spacecraft adapter during separation. The risk of collision and damage to the engine is considered and was one of the principal drivers for the interspacecraft adapter design. Further, to alleviate any heat transfer problems to the structure, high temperature MLI, in combination with a Titanium isolation cone is used to mount the engine.

The overall thermal design of the spacecraft uses a conventional insulated approach with MLI covering all surfaces except for the radiator. The radiator is placed on the same wall as the solar array to be assured that no fluxes are incident on the surface. The power required to maintain the spacecraft during cold case conditions is evaluated using both MATLAB and ESATAN.

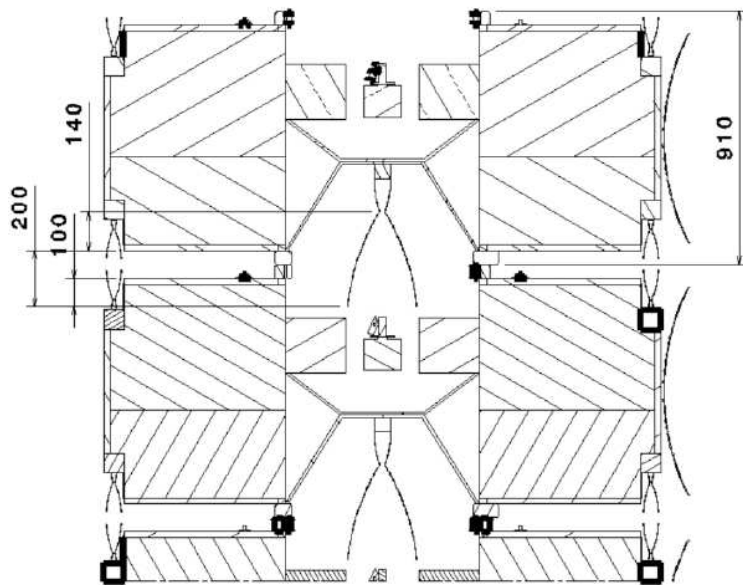

Figure C.26: Bi-propellant engine configuration (Note: vertical cut shown in Soyuz launch configuration A-A)