

CRANFIELD UNIVERSITY

MARC PIDOU

Hybrid membrane processes for water reuse

School of Applied Science
Department of Sustainable Systems
Centre for Water Science

PhD Thesis

CRANFIELD UNIVERSITY

School of Applied Science
Department of Sustainable Systems
Centre for Water Science

PhD Thesis

2006

MARC PIDOU

Hybrid membrane processes for water reuse

Supervisor: Dr. Bruce Jefferson

October 2006

**This thesis is submitted in partial fulfilment of the requirements for the degree of
Doctor in Philosophy**

**©Cranfield University, 2006. All rights reserved. No part of this publication may
be reproduced without the written permission of the copyright holder.**

Abstract

Water recycling is now widely accepted as a sustainable option to respond to the general increase of the fresh water demand, water shortages and for environment protection. Because greywater represents up to 70% of domestic wastewater volume but contains only 30% of the organic fraction and from 9 to 20% of the nutrients (Kujawa-Roeleveld and Zeeman, 2006), it is seen as one of the most appropriate sources to be treated and reuse. A broad range of technologies has been used for greywater recycling including soil filters (Itayama *et al.*, 2004), membranes (Ahn *et al.*, 1998) and biological aerated filters (Surendran and Wheatley, 1998). However, at small scale, such as individual household, the variability in strength and flow of the greywater and potential shock loading affect the efficacy of biological technologies. Moreover, simple physical processes, efficient to reduce the physical pollution within the greywater, are often limited to degrade the organic fraction (Jefferson *et al.*, 2000). There is then a need for alternative technologies that would not be affected by such problems and that could provide the treatment required for reuse.

This project investigated the potential of alternative technologies for greywater recycling. Four chemical systems, coagulation, MIEX[®], adsorption and membrane chemical reactor based on an advanced oxidation process (TiO₂/UV), were assessed at bench scale. Coagulation and MIEX[®] were found to achieve a limited treatment of the greywater and consequently to be not suitable in case of strict reuse standards. Whereas, adsorption with activated carbon and membrane chemical reactor provided a very good treatment of the greywater with an advantage to the advanced oxidation process as it could meet the strictest standard for reuse for BOD, turbidity and suspended solids as well as for the total and faecal coliforms.

Following this results the membrane chemical reactor was tested at pilot scale and compared to a benchmark system, a membrane bioreactor. Both systems achieved a very good treatment of the greywater; however, the MBR was found to be a more robust technology with all the samples tested for BOD and turbidity below the most stringent standards. The main difference between the two systems was observed in terms of the hydraulic conditions. Indeed, important membrane fouling was occurring in the MCR.

A more detailed study of membrane fouling in the MCR was carried out for a better understanding of the phenoma occurring. It was found that little fouling occurred when TiO₂ was dispersed in clean water. Alternatively, a significant fouling could be observed when TiO₂ was coated with specific products suggesting that a reaction occurs when TiO₂ is in solution with particular chemicals changing its fouling propensity.

Overall, the MBR was found to be the best technology in terms of performance and robustness. However, it was also found that spiking of domestic products can alter its performance due to their toxicity. Chemical systems, which are not affected by toxicity, seem to be a good alternative to biological systems. However, none of the systems tested here could match the effluent quality achieved by the MBR. Alternatively, the MCR achieved good treatment performance and limitation of the membrane fouling would make it a very good alternative.

Acknowledgements

This work forms part of the ‘Water Cycle Management for New Developments’ (WaND) project funded under the Engineering & Physical Science Research Council’s ‘Sustainable Urban Environment’ Programme by EPSRC, UK government and industrial collaborators [www.wand.uk.net].

A special thanks to my supervisor, Dr. Bruce Jefferson, for his help and advice throughout this project. I also thank him for his endless enthusiasm to show us the best of Britain, for the football and rugby games and the initiation to ‘proper’ English food and beers.

I also would like to thank all the people in the Center for Water Science who helped me in one way or another and without whom the completion of this project would not have been possible, especially Gaelle Raymond and Nicolas Brion for their precious help with the practical work.

Thank you to the French national football team for the good results in the last European championship and World cup that allowed me to tease the others.

Thank you to Thierry Henry and Arsenal for the great games.

Un très grand merci a Odile et Olivier pour votre aide et soutient pendant toutes ces années (...pas seulement le doctorat) qui m’ont permis d’en arriver la.

Merci a Franck pour m’avoir montré que rien n’est impossible.

Merci a Remi, Bernard, Renée, Géraldine et Arno pour leur soutient.

Et finalement un énorme merci a Kristell pour m’avoir fait rire dans les moments les plus durs, pour tout ce que nous avons fait ensemble jusqu’à maintenant et pour tout ce que nous ferons après et surtout ne changes rien ;o).

List of contents

Abstract.....	i
Acknowledgements.....	ii
List of contents.....	iii
List of figures.....	vii
List of tables.....	ix
Notations and abbreviations.....	xi
List of publications.....	xiv

Chapter 1	Introduction	1
------------------	---------------------	----------

Chapter 2	Literature review	3
------------------	--------------------------	----------

2.1	Background.....	3
2.2	Standards for greywater reuse.....	4
2.3	Greywater characteristics.....	9
2.4	Technologies for greywater recycling.....	13
2.4.1	Overview.....	13
2.4.2	Technologies.....	15
2.4.2.1	Simple.....	15
2.4.2.2	Chemical.....	17
2.4.2.3	Physical.....	20
2.4.2.4	Biological.....	24
2.4.2.5	Extensive.....	30
2.4.3	Processes installation and operation.....	33
2.4.4	Conclusions.....	34

Chapter 3	Materials and Methods	36
------------------	------------------------------	-----------

3.1	Materials.....	36
3.1.1	Feed.....	36
3.1.1.1	Fedden house site.....	36

3.1.1.2	<i>Showers</i>	37
3.1.2	Technologies	37
3.1.2.1	<i>Membrane bioreactor</i>	37
3.1.2.2	<i>Membrane chemical reactor</i>	38
3.1.2.3	<i>Bench-scale filtration system</i>	40
3.1.2.4	<i>Membranes specifications and cleaning</i>	41
3.2	Methods	42
3.2.1	Sampling	42
3.2.2	Analyses	43
3.2.2.1	<i>Standard analytical procedures</i>	43
3.2.2.2	<i>Fractionation</i>	43
3.2.2.3	<i>Zeta potential and charge density</i>	44
3.2.2.4	<i>Biomass characterisation</i>	44
3.2.3	Fouling determination	46
3.2.3.1	<i>Flux step method</i>	46
3.2.3.2	<i>Sustainable flux</i>	46
3.2.4	MIEX [®] and coagulation	46
3.2.4.1	<i>MIEX[®]</i>	46
3.2.4.2	<i>Coagulation</i>	47
3.2.5	Adsorption	48
3.2.6	Kinetics	48
3.2.6.1	<i>Bio-kinetics</i>	48
3.2.6.2	<i>Kinetic of catalytic reactions</i>	50
3.2.7	Dosing experiments	51
3.2.7.1	<i>Biological</i>	51
3.2.7.2	<i>Chemical</i>	52
3.2.8	Microtox	52

Chapter 4 Chemical solutions for greywater recycling 53

4.1	Coagulation and MIEX	53
4.1.1	Greywaters characteristics	53
4.1.2	Coagulation	55
4.1.3	MIEX	57

4.1.4	Combined systems.....	58
4.1.5	Comparison of the systems.....	59
4.1.6	Discussion.....	60
4.2	Adsorption.....	62
4.2.1	Background.....	62
4.2.2	Water sources.....	64
4.2.3	Results and discussion.....	65
4.2.3.1	<i>BOD removal</i>	65
4.2.3.2	<i>Optimum doses</i>	67
4.2.3.3	<i>Adsorption isotherms</i>	69
4.3	Semiconductor photocatalysis	72
4.3.1	Background.....	72
4.3.2	Membrane Chemical Reactor.....	73
4.3.2.1	<i>Performance</i>	73
4.3.2.2	<i>Membrane fouling</i>	74
4.4	Conclusion.....	75
<hr/>		
Chapter 5	Pilot study: MBR vs. MCR	78
<hr/>		
5.1	Performance	78
5.1.1	Results.....	78
5.1.2	Comparison.....	82
5.2	Kinetics.....	88
5.2.1	Bio-kinetics.....	88
5.2.2	Kinetics of catalytic reaction.....	91
5.3	Fouling studies.....	95
5.3.1	Short term fouling.....	95
5.3.2	Long term fouling.....	102
5.3.3	Discussion.....	105
<hr/>		
Chapter 6	Products influence on treatment process	109
<hr/>		
6.1	Influence of products on the properties of titanium dioxide to foul membranes	109

6.1.1	Introduction.....	109
6.1.2	Bench-scale membrane fouling experiments	109
6.1.2.1	<i>Influence of the products</i>	109
6.1.2.2	<i>Influence of the concentration</i>	112
6.1.2.3	<i>Particle size and surface analysis</i>	113
6.1.2.4	<i>Influence of the operating parameters</i>	116
6.2	Products spiking	119
6.2.1	Products toxicity.....	119
6.2.1.1	<i>Microtox</i>	119
6.2.2	Influence of products spiking on the technologies.....	123
6.2.2.1	<i>Biological</i>	123
6.2.2.2	<i>Chemical</i>	127
6.2.3	Discussion.....	129
Chapter 7	Conclusions	133
Chapter 8	Future work	135
Chapter 9	References	136
Chapter 10	Appendices	148
I-	Greywater characteristics	149
II-	Technology library	157
III-	Constructed wetlands descriptions and performances	218
IV-	Shower gels compositions	221
V-	Examples of Microtox results	224
VI-	List of ingredients of products	237

List of figures

Chapter 2	Literature review	
Figure 2.1	Distribution of the (a) turbidity, (b) total coliforms and (c) BOD values in mixed and bathroom greywater	10
Figure 2.2	Distribution of the flow rates of the reported technologies	15
Figure 2.3	Typical flow diagram of simple systems with either screening or sedimentation and disinfection	16
Figure 2.4	Typical flow diagram of chemical technologies with separation by filtration or flotation	18
Figure 2.5	Typical flow diagram for physical technologies	21
Figure 2.6	Typical flow diagram of biological technologies and submerged and side-stream MBRs	25
Figure 2.7	Typical flow diagram of extensive technologies	31
Chapter 3	Materials and methods	
Figure 3.1	Greywater collection system	36
Figure 3.2	High strength dosing system	37
Figure 3.3	Membrane bioreactor	38
Figure 3.4	Membrane chemical reactor	39
Figure 3.5	Bench-scale filtration system	40
Figure 3.6	Membranes	41
Figure 3.7	CST tester	46
Chapter 4	Chemical solutions for greywater recycling	
Figure 4.1	BOD residual after coagulation with alum and ferric for (a and b) mixed and (c and d) shower greywaters	56
Figure 4.2	BOD residual after MIEX [®] treatment for (a) mixed and (b) shower greywaters	57
Figure 4.3	BOD residual after MIEX [®] + coagulation with (a) alum and (b) ferric for shower greywater	58
Figure 4.4	BOD residual after adsorption in high (a) and medium (b) strength greywaters	65
Figure 4.5	Minimum BOD residual observed within the three greywaters after treatment with each adsorbent	66
Figure 4.6	Normalised Freundlich isotherms for the different adsorbents in the low, medium and high strength greywaters	70
Figure 4.7	Semiconductor photocatalysis (adapted from Parsons (2004))	72
Figure 4.8	Influence of (a) TiO ₂ , (b) the UV illumination, (c) the TiO ₂ dose and (d) the air velocity on the membrane permeability	77
Chapter 5	Pilot study: MBR vs. MCR	
Figure 5.1	Raw greywater and effluents (a) BOD and (b) turbidity concentrations with time	80
Figure 5.2	Distribution of the (a) BOD, (b) turbidity, (c) suspended solids and (d) total coliforms values from the effluent of the MBR, MCR and VFRB	87

Figure 5.3	Graphical determination of K_s and μ_{max} from the experimental data obtained by respirometry	88
Figure 5.4	Growth curves for different systems	91
Figure 5.5	Evolution of the DOC concentration with time in greywaters treated by photocatalytic oxidation	93
Figure 5.6	Evolution of the DOC concentration in the first 10 minutes of treatment of greywater by photocatalytic oxidation	93
Figure 5.7	Correlation between the apparent first order rate constant K' and the initial DOC concentration	94
Figure 5.8	Flux step test	96
Figure 5.9	Fouling rates for different air velocities U_{air} in the MBR with the (a) 300 kDa and (b) 150 kDa ceramic membranes	96
Figure 5.10	Fouling rates for different air lift velocities U_{air} in the MCR with the (a) polymeric and the (b) 300 kDa and (c) 150 kDa MWCO ceramic tubular membranes	97
Figure 5.11	Comparison of the fouling rate in the MCR and MBR with the 300 kDa and 150 kDa ceramic tubular membranes for an air lift velocity of $1.22 \text{ m}\cdot\text{s}^{-1}$	99
Figure 5.12	Evolution of the TMP with time for the ceramic tubular membranes in the MBR at different fluxes	103
Figure 5.13	Evolution of the TMP with time for the polymeric tubular membrane in the MCR at fluxes of 5 and $15 \text{ L}\cdot\text{m}^{-2}\cdot\text{h}^{-1}$	104
Figure 5.14	Fouling mechanisms for MBR (adapted from Judd, 2006)	106
<hr/>		
Chapter 6	Products influence on treatment process	
Figure 6.1	Fouling rates graph for different products	110
Figure 6.2	Fouling rates graph for different shower gels	111
Figure 6.3	Influence of the concentration on the fouling rates with (a) shower gel and (b) conditioner and bubble bath	112
Figure 6.4	Particle size distribution of the TiO_2 flocs in different solutions	113
Figure 6.5	Fouling rate vs. floc size	114
Figure 6.6	Microscope pictures of TiO_2 flocs (a) in tap water and (b) solution of shower gel Lynx	115
Figure 6.7	SEM pictures of (a) clean TiO_2 and (b) TiO_2 coated with shower gel Lynx	115
Figure 6.8	Fouling rates curves with and without UV illumination	116
Figure 6.9	Fouling rates for different UV illumination times	117
Figure 6.10	Fouling rates at different temperature	118
Figure 6.11	Typical graph obtained from the Microtox tests for (a) Original Source shower gel and (b) Morrisons all purpose cleaner	119
Figure 6.12	Oxygen uptake vs. time	124
Figure 6.13	Relative change in SOUR vs. dose for (a) the washing powders, (b) the bleaches, (c) the washing-up liquids and (d) the all purpose cleaners	125
Figure 6.14	Relative change in DOC removal vs. dose for (a) the washing powders, (b) the bleaches, (c) the washing-up liquids and (d) the all purpose cleaners	128

List of tables

Chapter 2 Literature review		
Table 2.1	Distribution of domestic water usage	4
Table 2.2	Worldwide standards for wastewater reuse	7
Table 2.3	Summary of greywaters characteristics (min-max (average))	12
Table 2.4	Distribution of applications.	14
Table 2.5	Distribution of the schemes by type of treatment	15
Table 2.6	Simple technologies	19
Table 2.7	Chemical technologies	19
Table 2.8	Physical technologies	23
Table 2.9	Biological technologies	28
Table 2.10	Extensive technologies	32
Chapter 3 Materials and methods		
Table 3.1	Membranes specifications	42
Table 3.2	Merck cell tests	43
Table 3.3	Adsorbents doses	48
Chapter 4 Chemical solutions for greywater recycling		
Table 4.1	Characteristics of the greywaters tested compared to wastewater and natural water	55
Table 4.2	Characteristics of the shower greywater effluent after treatment at optimum parameters	60
Table 4.3	Adsorbent properties	63
Table 4.4	Greywaters Characteristics	64
Table 4.5	BOD removal from greywater by different technologies	67
Table 4.6	Organic residuals after treatment at the optimum doses	68
Table 4.7	Microbiological contents	68
Table 4.8	Adsorption isotherms correlations	70
Table 4.9	Parameters from the normalised Freundlich isotherms obtained for each adsorbent in the 3 greywaters	71
Table 4.10	Performance of the MCR in batch operation	73
Chapter 5 Pilot study: MBR vs. MCR		
Table 5.1	Effluents quality with low strength greywater	78
Table 5.2	Effluents quality with high strength greywater	79
Table 5.3	Side stream MBR effluent quality with high strength greywater	81
Table 5.4	Operational data of MBRs	83
Table 5.5	Compliance level of the systems for different standards	86
Table 5.6	Bio-kinetic parameters	89
Table 5.7	Determination of the apparent first order rate constant K'	92
Table 5.8	Determination of the apparent first order rate constant K' for batch experiments	94
Table 5.9	Comparison of critical flux, J_c , for different systems	100
Table 5.10	Comparison of the fouling rates before and after the critical flux in different systems	101

Table 5.11	Comparison of the critical time, t_c , for different systems	103
Table 5.12	Biomass characteristics influencing membrane fouling	107

Chapter 6 **Products influence on treatment process**

Table 6.1	Particle size analysis.	114
Table 6.2	Toxicity of different domestic products.	120
Table 6.3	Toxicity of different chemicals contained in domestic products.	122
Table 6.4	Toxicity of different products and chemicals obtained by respirometry.	126
Table 6.5	Comparison of the toxicity and the actual dose of products in greywater.	131

Notations and abbreviations

μ_{\max}	maximum specific growth rate (bio-kinetics)
$1/n$	intensity parameter of the Freundlich isotherm
AA	activated alumina
AOP	advanced oxidation process
APEO	alkylphenol ethoxylates
BAF	biological aerated filter
BOD	bio-chemical oxygen demand
COD	chemical oxygen demand
CST	capillary suction time
d_{50}	median particle size
DOC	dissolved organic carbon
EC_{50}	concentration required to have an effect 50% of test organisms
EPS_c	carbohydrates concentration in the extracellular polymeric substances fraction
EPS_p	proteins concentration in the extracellular polymeric substances fraction
F:M	food to micro-organisms ratio
FeOOH	ferric hydroxide
GAC	granular activated carbon
GROW	green roof water recycling system
HAC	high activity activated carbon
HFRB	horizontal flow reed bed
HRT	hydraulic retention time
IC_{50}	concentration required to inhibit 50% of test organisms
J_c	critical flux
k	permeability factor
K'	apparent first order rate constant (kinetics)
K'_f	capacity factor of the normalised Freundlich isotherm
kDa	kilo Dalton
K_f	capacity factor of the Freundlich isotherm
K_s	half saturation constant (bio-kinetics)

LAS	linear alkylbenzene sulfonates
LC ₅₀	concentration required to kill 50% of test organisms
MAC	medium activity activated carbon
MBR	membrane bioreactor
MCR	membrane chemical reactor
MIEX [®]	magnetic ion exchange resin
MLSS	mixed liquor suspended solids
MLVSS	mixed liquor volatile suspended solids
MW	molecular weight
MWCO	molecular weight cut off
NF	nano-filtration
NH ₄ -N	ammonium
NO ₃ -N	nitrate
NOM	natural organic matter
NPEO	nonyphenol ethoxylates
O & M costs	operational and maintenance costs
OLR	organic loading rate
PEG	polyethylene glycol
PO ₄ -P	phosphate
-r	reaction rate
RO	reverse osmosis
SEM	scanning electron microscope
SMP _c	carbohydrates concentration in the soluble microbial products fraction
SMP _{COD}	COD concentration in the soluble microbial products fraction
SMP _p	proteins concentration in the soluble microbial products fraction
SMP _{turbidity}	turbidity concentration in the soluble microbial products fraction
SOUR	specific oxygen uptake rate
SRT	solids retention time
SS	suspended solids
SUVA	specific UV absorbance
t _c	critical time
TiO ₂	titanium dioxide
TKN	total Kjehldahl nitrogen
TMP	trans-membrane pressure

T-N	total nitrogen
TOC	total organic carbon
T-P	total phosphorous
TSS	total suspended solids
U_{air}	air velocity
UF	ultra-filtration
UV	ultra violet
UV_{254}	UV absorbance at the wavelength of 254 nm
VFRB	vertical flow reed bed
XOC	xenobiotic organic compound
Y	yield coefficient (bio-kinetics)
τ	reaction time

List of publications

Conference papers:

M. Pidou, L.M. Avery, T. Stephenson, P. Jeffrey, S. Liu, F. A. Memon, B. Jefferson. The efficacy of adsorption processes for greywater reuse in urban environments. In: 6th IWA Young Researchers conference, Leeds, UK. 6-7 April 2005.

M. Pidou, A. Palmer, L.M. Avery, P. Jeffrey, T. Stephenson, S. J. Judd, B. Jefferson. Robustness of technology solutions for grey and black water recycling in urban environments. In: WateReuse Association Conference, Phoenix, USA. 19-22 September 2004

M. Pidou, L.M. Avery, T. Stephenson, S. A. Parsons, P. Jeffrey, S. Liu, F. A. Memon, B. Jefferson. Chemical solution for greywater recycling. In: WateReuse Association Conference, Phoenix, USA. 19-22 September 2004

Journal papers:

M. Pidou, L.M. Avery, T. Stephenson, S.A. Parsons, P. Jeffrey, S. Liu, F.A. Memon, B. Jefferson (2006). Chemical solutions for greywater recycling. *Chemosphere*, **Submitted**.

M. Pidou, L.M. Avery, T. Stephenson, P. Jeffrey, S. Liu, F.A. Memon, B. Jefferson (2006). Greywater recycling: A review of treatment options and applications. *Proceedings of the Institution of Civil Engineers, Engineering Sustainability*, **Submitted**.

M.J. Rivero, S.A. Parsons, P. Jeffrey, M. Pidou and B. Jefferson (2006). Membrane chemical reactor (MCR) combining photocatalysis and microfiltration for grey water treatment. *Water Science and Technology*, **53** (3), 173-180.

F.A. Memon, D. Butler, W. Han, S. Liu, C. Makropoulos, L.M. Avery and M. Pidou (2005). Economic assessment tool for greywater recycling systems. *Proceedings of the Institution of Civil Engineers, Engineering Sustainability*, **158**, ES3, 155-161.

Chapter 1 Introduction

General concern about the diminution in fresh water availability has risen in recent years. Water recycling is commonly seen as one of the main options to remedy water shortage caused by the increase of the water demand and droughts as well as a response to some economical and environmental drivers. The main options for wastewater recycling are industrial, irrigation, aquifer recharge and urban reuse.

Urban recycling involves the treatment and reuse of black, grey and/or rain waters. Whilst sewage effluent is often used to recharge aquifer and irrigate crops, blackwater, which is effectively a concentrated sewage, is not commonly considered due to the high concentrations of pollutants within it (Elmitwalli *et al.*, 2006). Rainwater whilst relatively clean is limited as a large source of reuse due to its intermittent nature and limited levels in some parts of the world. However, greywater represents up to 70% of the domestic wastewater but contains only 30% of the organic load (Kujawa-Roeleveld and Zeeman, 2006). Greywater, defined as domestic wastewater excluding toilet flushing, generally includes wastewaters from baths, showers, hand basins, washing machines, dishwashers and kitchen sinks. However, at small scale the more polluted sources such as washing machines, dishwashers and kitchen sinks tend to be excluded whereas at larger scale all sources are used to maximize water savings. The most common application for greywater reuse is toilet flushing which has been found to reduce water demand within dwellings by up to 30% (Karpiscak *et al.*, 1990). However, other applications such as irrigation of gardens, parks, school yards, cemeteries and golf courses, vehicle washing, fire protection and air conditioning have been reported (Lu and Leung, 2003).

A broad range of technologies has already been used for greywater recycling including reed beds (Dallas *et al.*, 2004), sand filters (Itayama *et al.*, 2004), membranes (Ahn *et al.*, 1998) and membrane bioreactors (MBRs) (Liu *et al.*, 2005). However, at small scale the variability in strength and flow of the greywater and potential shock loading affect the efficacy of biological technologies. Moreover, simple physical processes, efficient to reduce the physical pollution within the greywater, are often limited to degrade the organic fraction (Jefferson *et al.*, 2000). Consequently, there is gap for alternative options that would not suffer from these limitations. Chemical processes have been limitedly investigated for greywater

recycling. However, chemical processes such as coagulation, adsorption and advanced oxidation process (AOP) provide great potential for the removal of the organic fraction contained within greywater. Indeed, coagulation with metal salts is the most common process used for the removal of high concentrations of dissolved organics in drinking water (Parsons and Jefferson, 2006). Moreover, adsorption has been widely used to remove organic matter from both wastewater and drinking water (Aksu, 2005). Typical pollutants removed by adsorption include pesticides, herbicides, detergents, polycyclic aromatic hydrocarbons, trihalomethanes and traces of heavy metals (Dabrowski, 2001). Similarly, AOPs and more precisely the photo-catalytic process combining titanium dioxide (TiO_2) and UV light have been reported to treat a wide range of organics in both drinking and waste waters (Legrini *et al.*, 1993).

The objectives of this work are:

- To assess the potential of chemical processes such as coagulation, ion exchange, adsorption and advanced oxidation process (AOP) (TiO_2/UV) for the treatment of greywater for reuse;
- To compare the operation and performance at pilot scale of a chemical process, the membrane chemical reactor (MCR), against a benchmark biological system, membrane bioreactor (MBR);
- To understand the influence of the different products contained within greywater on the treatment achieved by the technologies;

Overall the thesis aims to understand alternative treatment options for greywater recycling in urban environments.

It should be noted that the experimental work on the batch operation of the MCR was carried out by Maria Rivero, the flux step tests on the MBR and all the tests on the bench-scale cross flow filtration rig were performed by Gaëlle Raymond and the Microtox analysis and the respirometry experiments were achieved by Nicolas Brion.

Chapter 2 **Literature review**

2.1 Background

Wastewater recycling has been practiced all over the world for different reasons which include the increase of the fresh water demand, water shortages and drought, economic drivers, and environment and public health protection (USEPA, 2004). The increase in water demand is mainly due to the general augmentation of the world's population. This also induces a rise in the wastewater production. Consequently wastewater, if recycled, becomes an immense source of water that could potentially cover the lack of fresh water observed elsewhere. Worldwide, the most common application for wastewater recycling is agricultural irrigation (Laine, 2001). However, other options such as industrial, recreational, environmental and urban reuse have been practised (Judd, 1998). The potential sources identified for urban reuse are sewage (Seo *et al.*, 2004), grey (March *et al.*, 2004) and rain (Dallmer, 2002) waters. Greywater is defined as domestic wastewater excluding toilet flush. In some cases, mixed rain and grey waters (Hills *et al.*, 2001) have been used as well as a 'light greywater' including only the sources from the bathroom (Jefferson *et al.*, 2004). The advantage of recycling greywater is that it is a large source with a low organic content. To illustrate, greywater represents up to 70% of the total consumed water but contains only 30% of the organic fraction and from 9 to 20% of the nutrients (Kujawa-Roeleveld and Zeeman, 2006). Moreover, in an individual household, it has been established that greywater could support the amount of water needed for toilet flushing and outdoor uses such as car washing and garden watering (Karpiscak *et al.*, 1990). For example in the UK, on average, toilet flushing and outdoor use represent 41% of the total domestic water usage whereas greywater from shower, bath, hand basin, laundry and dishwasher correspond to 44% (Table 2.1). However, at larger scale, other applications such as irrigation of parks, school yards, cemeteries and golf courses, fire protection and air conditioning have been considered (Lu and Leung, 2003).

Table 2.1: Distribution of domestic water usage (Environment Agency UK, 2006).

Toilet flushing	35%
Wash basin	8%
Shower	5%
Bath	15%
Laundry	12%
Dishwasher	4%
Outside use	6%
Kitchen sink	15%

2.2 Standards for greywater reuse

No international regulations have been published to control the quality of treated effluent for reuse. However, countries individually produced their own guidelines depending on their needs. Because the main issue when using recycled water is the potential risk to human health, the standards are usually based on microbial content. However, as it has often been shown, the aesthetics of the water to be reused is probably as important because of the perception of the public (Jeffrey and Jefferson, 2003; Hurlimann and McKay, 2006). Therefore, the standards include parameters for the treatment of the organics and solids fractions such as biochemical oxygen demand (BOD), suspended solids (SS) and turbidity. Occasionally, they contain limits for other parameters such as ammonia, phosphorus, nitrogen and chlorine residual (Table 2.2).

The USA and more precisely the state of California was the first to actually adopt its own water reclamation and reuse standards for agricultural irrigation in 1918 and has continually revised them since then, particularly to add new applications. Later, the state of Florida developed its own regulations, and finally, with the increase of interest for water reuse, the US Environmental Protection Agency (EPA) published guidelines in 1992 to provide assistance to states that have not created their own regulation (Crook and Surampalli, 1996). A majority of the states have now regulations or guidelines for wastewater reuse for at least urban and agricultural applications (Table 2.2). Australia published its first guidelines for the use of reclaimed water in the late 1970s (Gregory *et al.*, 1996). More recently, each state produced its own guidelines for general wastewater recycling, and the use of different sources of wastewater to be reused such as greywater was defined. A general consultation is currently being carried out to create national guidelines (Radcliffe, 2004). In contrast, there is no

general water quality criteria published for water reuse in the European Union. It has then often been assumed that greywater should be treated to either potable or bathing water standards. However, countries such as Germany and Spain have produced their own standards. Finally, countries all over the world have now their own guidelines or standards for water reuse (Table 2.2).

The differences observed between published reuse criteria reflect differences in need, application and social factors. For example when considering garden watering, simple bucketing of untreated greywater is permitted in Western Australia (Government of Western Australia, 2005) whereas a water quality of BOD $<10 \text{ mg.L}^{-1}$, suspended solids $<5 \text{ mg.L}^{-1}$, turbidity $<2 \text{ NTU}$ and faecal coliforms $<2.2 \text{ cfu.100mL}^{-1}$ is required in British Columbia, Canada (CMHC, 2004). The standards also reflect accessibility of the public such that greywater recycling can only occur in unsewered areas in Queensland, Australia (Queensland Government, 2003). Where generally permitted the standards are stricter where access is unrestricted. To illustrate, in New South Wales, Australia, the standards decrease from 20 to 10 mg.L^{-1} for BOD and from no criteria to 30 and then $10 \text{ cfu.100mL}^{-1}$ for total coliforms for reuse as subsurface irrigation, surface irrigation and toilet flushing respectively (New South Wales Government, 2005). The manner in which application areas are divided also differs and range from general to very specific. To illustrate, countries such as the USA (USEPA, 2004) or Costa Rica (Dallas *et al.*, 2004) defined large classes of applications such as urban reuse and agricultural irrigation. Alternatively, China has different standards for specific applications such as toilet flushing, washing and irrigation of lawn (Ernst *et al.*, 2005). Moreover, in addition to the standards, some requirements include minimum treatment trains, as it is the case in most of the American states where the water to be reused must undergo at least secondary treatment and disinfection or oxidation and disinfection (USEPA, 2004). These are often coupled with other requirements of monitoring and sampling to ensure that the process is continuously meeting the consents and to detect any problem as quickly as possible. For instance, in British Columbia, Canada, treated wastewater for reuse must be monitored weekly for BOD and pH, daily for suspended solids and faecal coliforms and continuously for turbidity (CMHC, 2004).

All of the above differences result in a range of values for the chosen water quality parameters. For instance, standards for BOD, turbidity, faecal coliforms and total coliforms range from $5\text{-}40 \text{ mg.L}^{-1}$, $2\text{-}20 \text{ NTU}$, $0\text{-}10^3 \text{ cfu.100mL}^{-1}$ and $0\text{-}10^4$

cfu.100mL⁻¹ respectively. The UK has no standards for urban water reuse although some have been proposed in the industry based on bathing water compliance. In their report, Mustow and Grey (1997) recommended standards for greywater reuse essentially based on organisms' control with undetectable level of faecal coliforms in the effluent. However, consideration of all of the standards from around the world suggests that specific targets of BOD <10 mg.L⁻¹, turbidity <2 NTU and a non detectable level of faecal coliforms.100 mL⁻¹ is a sensible conservative level and will be used as the main performance criteria throughout this thesis.

Table 2.2: Worldwide standards for wastewater reuse.

	Application	Parameters								
		BOD ₅ *	TSS*	Turbidity**	T-N*	T-P*	NH ₄ -N*	Faecal Coliforms [~]	Total Coliforms [~]	Residual Chlorine*
China (Ernst <i>et al.</i> , 2005)	Toilet flushing	<10	<1500 ¹	<5	-	-	<10	3	-	>1 after 30 min,
	Irrigation of green	<20	<1000 ¹	<20	-	-	<20	3	-	>0.2 at point of use
	Washing purpose	<10	<1000 ¹	<5	-	-	<10	3	-	
Japan (Tajima, 2005)	Toilet flushing	-	-	<2	-	-	-	-	ND ²	free > 0.1,
	Landscape	-	-	<2	-	-	-	-	<1000	combined
	Recreational	-	-	<2	-	-	-	-	ND ²	>0.4
Taiwan (Lin <i>et al.</i> , 2005)	Toilet flushing	10	-	-	-	-	-	-	<10 ²	Trace
Israel (Gross <i>et al.</i> , 2006)	Wastewater reuse	10	10	-	-	-	-	<1	-	-
Germany (Nolde, 1999)	Wastewater reuse	<5 ³	-	-	-	-	-	<1000	<10000	-
Spain, Canary Islands (USEPA, 2004)	Wastewater reuse	10	3	2	-	-	-	-	2.2	1
Canada, British Columbia (CMHC, 2004)	Unrestricted urban reuse	10	5	2	-	-	-	2.2	-	-
Costa Rica (Dallas <i>et al.</i> , 2004)	Irrigation of food crops	<40	-	-	-	-	-	<1000	-	-
	Urban reuse	<40	-	-	-	-	-	<100	-	-

*: mg.L⁻¹, **: NTU, ~: CFU.100mL⁻¹, -: not applicable, ND: not detectable, ¹: as TDS, ²: as *E. Coli*, ³: as BOD₇.

	Application	Parameters								
		BOD ₅ *	TSS*	Turbidity**	T-N*	T-P*	NH ₄ -N*	Faecal Coliforms [~]	Total Coliforms [~]	Residual Chlorine*
USEPA (USEPA, 2004)	Wastewater reuse	-	-	-	-	-	-	14 for any sample 0 for 90%	-	-
USA, Texas (USEPA, 2004)	Unrestricted water reuse	5	-	3	-	-	-	20 avg 75 max	-	-
USA, California (USEPA, 2004)	Unrestricted water reuse	-	-	2 avg 5 max	-	-	-	-	2.2 avg 23 max in 30 days	-
USA, Florida (USEPA, 2004)	Unrestricted water reuse	20	5	-	-	-	-	25% of sample ND and 25 max	-	-
USA, Washington (USEPA, 2004)	Unrestricted water reuse	30	30	2 avg 5 max	-	-	-	2.2 avg 23 max	-	-
Australia, Queensland (2003)	Greywater reuse for garden watering in unsewered area	20	30	-	-	-	-	-	100	-
Australia, New South Wales (2005)	Greywater for Subsurface irrigation	90%<20 max 30	90%<30 max 45	-	-	-	-	-	-	-
	Surface irrigation	90%<20 max 30	90%<30 max 45	-	-	-	-	-	90%<30 max 100	>0.2 <2
	Toilet / Washing machine	90%<10 max 20	90%<10 max 20	-	-	-	-	-	90%<10 max 30	>0.5 <2

*: mg.L⁻¹, **: NTU, ~: CFU.100mL⁻¹, -: not applicable, ND: not detectable, avg: average, max: maximum.

2.3 Greywater characteristics

Greywater is generated as a result of the living habits of the people involved, the products used and the nature of the installation and as such its characteristics are highly variable (Eriksson *et al.*, 2002). Furthermore, greywater is a complex mixture of wastewaters coming from the different domestic appliances. A review of the characteristics of different greywaters presented in Appendix I and summarised in Table 2.3 confirms this variability. Indeed, BOD ranging from 5 to 1460 mg.L⁻¹, suspended solids ranging from 15 to 720 mg.L⁻¹, turbidity ranging from 21 to 444 NTU and total coliforms ranging from 10¹ to 10⁸ cfu/100mL have been reported in the literature (Appendix I). A more detailed analysis of these ranges for mixed and bathroom greywaters (Figure 2.1) reveals that the data is not normally distributed. For instance, 80% of the turbidity data were below 115 NTU although the maximum value was 444 NTU. Similarly, 60% of the total coliforms values (Figure 2.1b) were below 1.9×10⁴ cfu.100mL⁻¹ and 80% of them were below 1.2×10⁶ cfu.100mL⁻¹. In contrast, the straight-line like distribution curve obtained for BOD suggested a fairly even distribution of the values on the range observed.

Analysis of the characteristics by source type indicates that kitchen and laundry sources are higher than the other sources in both organics and physical pollutants (Table 2.3; Eriksson *et al.*, 2002). This is explained by the fact that kitchen sinks waters carry food wastes and laundry waters contain a large amount of washing powder for its small volume and also other particles such as sand and clay for families with outdoor activities for example (Rose *et al.*, 1991). In contrast, the bathroom wastewaters, sometimes called 'light greywater', are mainly composed of the washing products and hair and are diluted in a larger volume and consequently represent a smaller organic fraction (Table 2.3).

Physical pollutants levels are typically within the range 33-240 NTU for mixed greywater which represents a very high turbidity when compared to sewage or potable raw waters. The particles that make up the turbidity have been observed principally in the 5-200 µm range (Ramon *et al.*, 2004). Similarly, Jefferson *et al.* (2004) reported particle size from the different bathroom sources to be mainly between 10 and 100 µm and molecules within mixed greywater with molecular weight generally below 3 kDa.

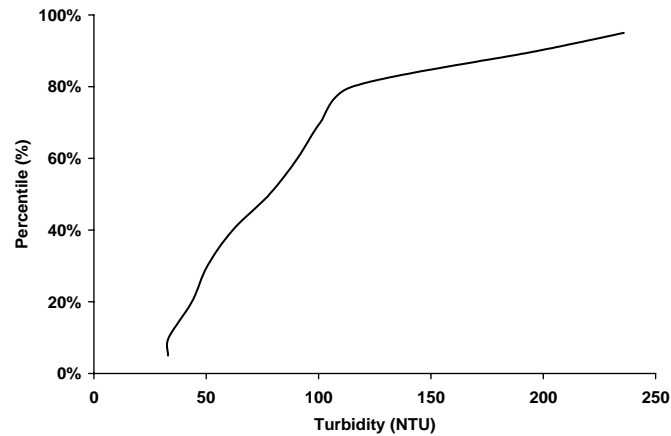

(a)

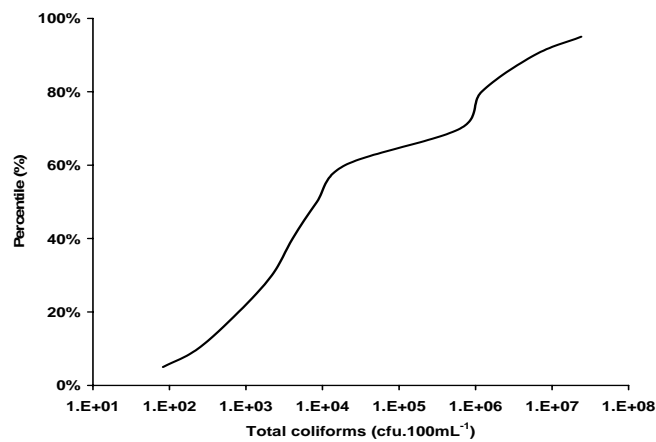

(b)

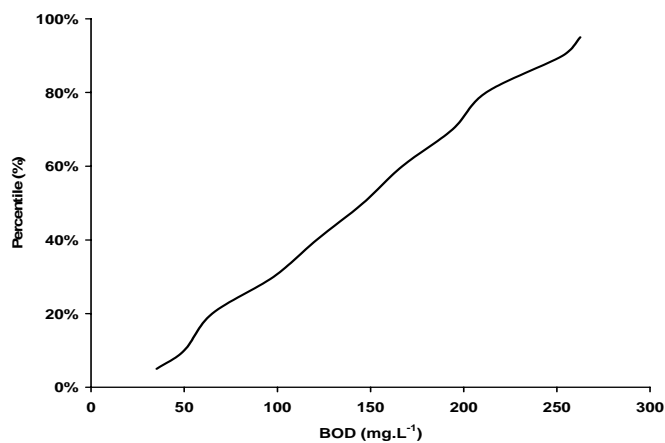

(c)

Figure 2.1: Distribution of the (a) turbidity, (b) total coliforms and (c) BOD values in mixed and bathroom greywater.

With average concentrations of 154 and 113 mg.L⁻¹ for BOD and suspended solids respectively, mixed greywater has similar concentrations to a low to medium strength sewage (Table 2.3). A closer look at the concentrations reported for each appliance shows that bathroom wastewaters are also comparable to a low to medium strength sewage whereas laundry water is equivalent to a medium to high strength and finally

kitchen sink water to very high strength sewage. On average for all sources reviewed here, the COD/BOD ratio is around 3.2. Typical values for domestic sewage and for final effluent are 2.2 and 3-10 respectively (Metcalf and Eddy, 2003). Higher values such as the one found for greywater suggest a limitation for biodegradability. This is supported by the values obtained for the COD:N:P ratio of 1:0.02:0.01 for mixed greywaters. Indeed, comparison with the same ratio for sewage, 1:0.09:0.02 (Metcalf and Eddy, 2003), confirms greywater's low nutrient content and consequently its poor biodegradability. However, a closer look at the concentrations in the wastewaters of each appliance will show that the wash basins and laundry sources contain higher phosphorous concentrations with COD:N:P ratios of 1:0.02:0.06 and 1:0.02:0.15 respectively. The lack of nitrogen and phosphorus is not surprising as in wastewater they are in majority derived from human excretions. Indeed, 82% of N and 68% of P from the total domestic load originate from faeces and urine (Kujawa-Roeleveld and Zeeman, 2006).

In all sources, the microbial contents varied considerably between 10^1 and 10^8 cfu/100mL. Coliform content is known to depend on the demographic distribution of the residents within each catchment. For instance, in their study Rose *et al.* (1991) showed that higher total and faecal coliforms count were found in the greywater from families with young children with 3.2×10^5 and 1.5×10^3 cfu.100mL⁻¹ respectively in contrast to 80 and 6 cfu.100mL⁻¹ for families without children. Similarly, Ottoson and Stenstrom (2003) reported high and variable concentrations of the different faecal indicators such as $10^{5.5}$ - $10^{8.7}$ cfu.100mL⁻¹ for coliforms, $10^{4.3}$ - $10^{6.8}$ cfu.100mL⁻¹ for *E. Coli*, 10^3 - $10^{5.1}$ cfu.100mL⁻¹ for faecal enterococci, $10^{2.3}$ - $10^{4.8}$ cfu.100mL⁻¹ for *C. perfringens* spores and $10^{1.4}$ - 10^4 cfu.100mL⁻¹ for somatic coliphages in greywater collected from a housing estate in Sweden. In most studies microbiological contamination is reported using the indicators such as *E. Coli*, faecal coliforms and total coliforms. However, a range of bacteria, pathogenic viruses, protozoa or helminths could potentially be found in greywater. Indeed, these micro-organisms could be introduced by hand washing after toilet use, washing of babies, laundry of contaminated clothes (e.g. diapers) or even food washing in the kitchen (Eriksson *et al.*, 2002; Ottoson and Stenstrom, 2003).

Table 2.3: Summary of greywaters characteristics (min-max (average)).

Source	BOD (mg.L ⁻¹)	SS (mg.L ⁻¹)	Turbidity (NTU)	Total coliforms (cfu/100mL)
Mixed greywater	5-466 (154)	25-304 (113)	33-240 (84)	10 ² -10 ⁸ (10 ⁷)
Bath	129-192 (161)	47-58 (53)	46-60 (53)	10 ² -10 ⁴ (10 ³)
Shower	99-212 (155)	15-353 (173)	21-375 (131)	10 ¹ -10 ⁴ (10 ⁴)
Hand basin	33-252 (138)	36-505 (183)	102-164 (133)	10 ³ -10 ⁶ (10 ⁵)
Kitchen	536- 1460 (891)	235-720 (528)	-	-
Laundry	48-472 (276)	68-465 (238)	50-444 (254)	10 ³ -10 ⁶ (10 ⁵)
Standards	<10	<10	<2	ND
Aiyuk <i>et al.</i> (2004)	200±15	208±213	-	10 ⁷ ±10 ²
Sewage El-Khateeb <i>et al.</i> (2003)	282±68	191±68	-	2.4×10 ⁹ ±2.2×10 ⁹
Coté <i>et al.</i> (1997)	118	187	-	5.6×10 ⁷

Beside the general water quality parameters seen above, a few studies have focussed on specific components present in greywater. For instance, Palmquist and Hanæus (2005) and Eriksson *et al.* (2002) reported the presence of heavy metals such as cadmium, chromium, cobalt, copper, lead, nickel, tin and zinc in greywater. Furthermore, Eriksson *et al.* (2002 and 2003) identified large quantities of xenobiotic organic compounds (XOCs) in greywater. The XOCs found in common domestic products are potentially toxic and an environmental risk if released after reuse of the greywater. The most common and most toxic XOCs reported were surfactants such as benzalkonium chloride and alkylphenol ethoxylates, preservatives and antioxidants such as bronopol and triclosan, softeners such as diisononylphtalate and phosphonates, solvent such as heptane and 1,2,4-trichlorobenzene and fragrances and flavours such as hexyl cinnamic aldehyde and styrene because they are not biodegradable, potentially bio-accumulative with a bio-concentration factor (BCF) over 100 and a log K_{ow} over 3 and toxic with EC/LC₅₀ below 1 mg.L⁻¹ (Eriksson *et al.*, 2002). To illustrate, Eriksson *et al.* (2006) reported in their study that laundry and kitchen waters were the sources contributing the most to the general toxicity of greywater.

Finally, a comparison of the standards to be achieved and the actual concentrations in the raw greywaters will provide a better view on what should be removed by a technology used for greywater recycling. In urban environments, the most common reuse application is toilet flushing and the standards to be met for this application are generally (Appendix I) as follow: BOD and suspended solids below 10 mg.L^{-1} , turbidity below 2 NTU and undetectable levels of coliforms. To achieve such standards, on average removals of 93-99% for BOD, 81-98% for suspended solids, 81-96% for turbidity and 3-7 log for total coliforms will be necessary. Consequently, the technologies chosen for the recycling of greywater will be required to achieve excellent performance and to be able to significantly alter most of the different fractions present in the greywater.

2.4 Technologies for greywater recycling

2.4.1 Overview

Investigations of treatment and recycling of greywater have been reported since the 1970's (Arika *et al.*, 1977; Hall *et al.*, 1974; Hypes *et al.*, 1975; Winneberger, 1974). The first technologies studied were mainly physical treatment such as coarse filtration or membranes often coupled with disinfection (Hall *et al.*, 1974; Hypes *et al.*, 1975). Later in the 1980's and 1990's, mostly biological technologies such as rotating biological contactor (Nolde, 1999), biological aerated filters (Laine, 2001; Surendran and Wheatley, 1998) and aerated bio-reactors (Brewer *et al.*, 2000; Santala *et al.*, 1998; Shin *et al.*, 1998) were investigated. During the same period, simple physical separators coupled with disinfection were being developed and installed in single house installations (Brewer *et al.*, 2000; CMHC, 2002; Hills *et al.*, 2003). In the late 1990's reports also emerged on the use of advanced technologies such as MBRs (Andersen *et al.*, 2001; Friedler, 2005; Goddard, 2006; Liu *et al.*, 2005) and alternatively cheaper extensive technologies such as reed beds (Fittschen and Niemczynowicz, 1997; Gross *et al.*, 2006; Li *et al.*, 2003; Shrestha *et al.*, 2001) and ponds (Dallas *et al.*, 2004; Gunther, 2000). Interestingly, only three chemical treatments, electro-coagulation (Lin *et al.*, 2005), conventional coagulation (Sostar-Turk, 2005) and advanced oxidation process (Parsons *et al.*, 2000), were reported in the literature.

Schemes for greywater recycling have been found in most parts of the world. No specific trend could be identified between the types of treatment used and the locations; although it is thought that poorer countries will favour the use of low costs and low maintenance technologies for economical reasons. For instance, Dallas and Ho (2004) investigated the use of fragments of PET plastic from water bottles as a cheaper media in constructed wetlands in Costa Rica. Similarly, in Jordan, Bino (2004) used a simple, low cost and easy to build treatment system made of plastic barrels. Further, in Oman, Prathapar *et al.* (2006) designed and tested a low cost, low maintenance system based and activated carbon, sand filtration and disinfection for the treatment of ablution water in a mosque.

Twenty five of the sixty three schemes reviewed (Appendix II) were pilot or bench scale systems for research purpose. The other 38 systems were full scale as they were fitted in buildings and the treated greywaters were reused for specific applications. The different applications reported were toilet flushing, irrigation or garden watering, outdoor use and cleaning, laundry and infiltration (Table 2.4). Toilet flushing and irrigation were the most commonly used applications with 54 and 36 % of the schemes respectively.

Table 2.4: Distribution of applications.

Applications	
Toilet flushing	54 %
Irrigation and Garden watering	36 %
Outdoor use and cleaning	5 %
Laundry	2.5 %
Infiltration	2.5 %

Most of the full scale schemes were installed in individual houses; only twelve of them were at a bigger scale such as stadiums, hotels, group of houses or residences. The different schemes reported varied a lot in size and the treated effluent flow rates were found to vary between 0.01 and 622 m³.day⁻¹. However, 70% of the schemes (of which the flow rate was known) had a flow rate below 3.4 m³.day⁻¹ (Figure 2.2).

Another way to evaluate these schemes is to classify them by type of treatment. It was then possible to group them into five categories as follow: simple (coarse filtration and disinfection), physical (sand filter, adsorption and membrane), biological

(biological aerated filter, rotating biological contactor and membrane bioreactor), extensive (constructed wetlands) and chemical (electro-coagulation and coagulation).

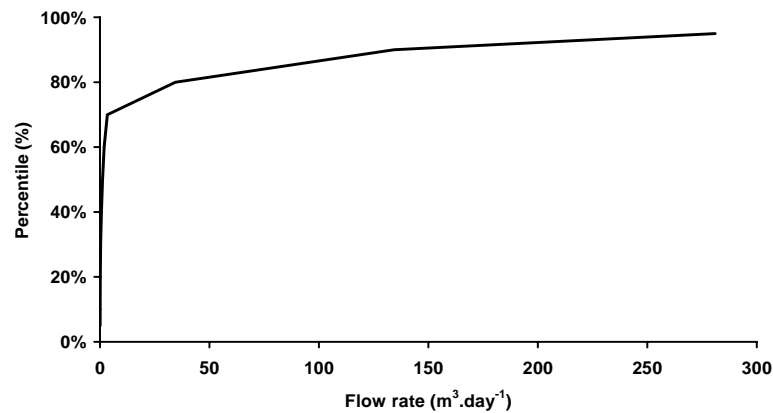

Figure 2.2: Distribution of the flow rates of the reported technologies.

Most of these technologies are operated with a screening or sedimentation stage before and/or a disinfection stage (UV, chlorine) after. For instance, Nolde (1999) reported the treatment of greywater with a rotating biological contactor preceded by a sedimentation tank and followed by UV disinfection. Similarly, Friedler (2005) reported the use of a 1 mm screen and disinfection with hypochlorite respectively before and after a membrane bioreactor. The most commonly used technologies are the biological systems followed by extensive and physical treatments (Table 2.5).

Table 2.5: Distribution of the schemes by type of treatment.

Technology	Number	%
Simple	8	12.7
Physical	13	20.6
Biological	25	39.7
Extensive	15	23.8
Chemical	2	3.2
Total	63	100

2.4.2 Technologies

2.4.2.1 Simple

Simple technologies (Table 2.6) used for greywater recycling are usually two-stage systems based on a coarse filtration or sedimentation stage to remove the larger solids followed by disinfection (Figure 2.3) (Brewer *et al.*, 2000; Hills *et al.*, 2003; March *et*

al., 2004). Mars (2004) reported the use of even simpler systems with only a coarse filter or a sedimentation tank in Western Australia where the regulation allows the reuse of greywater after such simple treatment for subsurface irrigation.

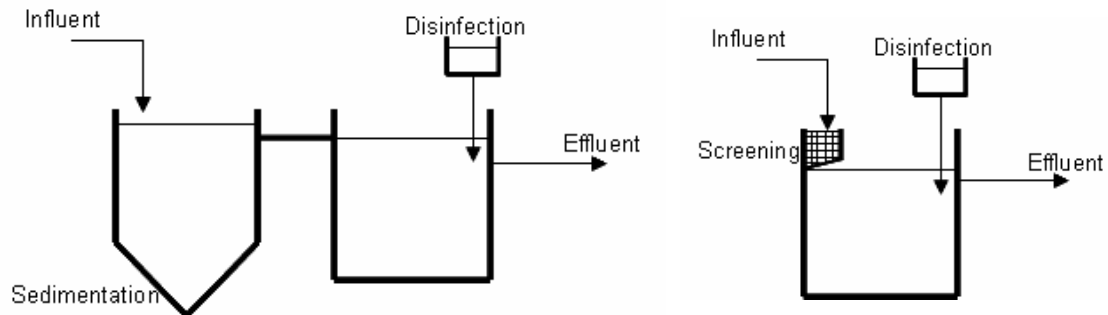

Figure 2.3: Typical flow diagram of simple systems with either screening or sedimentation and disinfection.

Simple technologies provide only a limited treatment of the greywater in terms of organics and solids. To illustrate, average removals of 70, 56 and 49% for COD, suspended solids and turbidity have been reported in the literature (Table 2.6). However, good removal of micro-organisms due to the disinfection stage have been observed with total coliforms residuals below $50 \text{ cfu} \cdot 100\text{mL}^{-1}$ in the treated effluents (Brewer *et al.*, 2000; Hills *et al.*, 2003). Consequently, these systems are preferably used at small scale such as single household. Moreover, they are usually used to treat low strength greywater from bath, shower and hand basin due to the limited treatment they can achieve and subsequent applications are toilet flushing and garden watering. Little information is available in the literature on the hydraulic performance of these systems; however, the hydraulic retention time (HRT) should be short as a result of their simplicity. March *et al.* (2004) reported a HRT of 38 hours for a large scale system installed in an 81-room hotel in Spain.

Simple systems are marketed and promoted as being simple to use and with low operational costs (Diaper *et al.*, 2001). However, two systems installed in individual household in the United Kingdom with similar capital and operational and maintenance (O & M) costs of £1195 and £50/year and £1625 and £49/year respectively were found to be economically unsustainable as the water savings were not sufficient to cover the O & M costs (Brewer *et al.*, 2000; Hills *et al.*, 2003). Only the scheme located in the hotel in Spain was reported to be economically viable. Indeed, the system including two $300 \mu\text{m}$ nylon filters, a sedimentation tank and

disinfection with sodium hypochlorite had a capital cost of 17000 € (~£11500) and the O & M cost were calculated at 0.75 € (~£0.50) per cubic meter. A saving of 1.09 € (~£0.74) per cubic meter was then attained and a pay back period of 14 years was obtained with the system operative only 7 months per year.

2.4.2.2 Chemical

Only three schemes using a chemical technology for greywater recycling were reported in the literature (Table 2.7; Figure 2.4). The treatment technology of two of the schemes was based on coagulation with aluminium. The first one was a combination of coagulation, sand filter and granular activated carbon (GAC) for the treatment of laundry greywater (Sostar-Turk *et al.*, 2005). The second was combining electro-coagulation with disinfection for the treatment a low strength greywater (Lin *et al.*, 2005). The latter provided a good treatment of the greywater with BOD and suspended solids residuals of 9 mg.L⁻¹, a turbidity residual of 4 NTU and undetectable levels of *E. Coli*. However, it should be noted that the source had a really low organic strength with a BOD concentration of 23 mg.L⁻¹ in the raw greywater. The first system also achieved a good treatment with residuals of 10 mg.L⁻¹ for BOD and below 5 mg.L⁻¹ for the suspended solids, with the coagulation stage itself achieving 51% of the BOD removal and 100% of the suspended solids removal. The two technologies achieved these treatments with rather short contact times. Indeed, the hydraulic retention time in the two schemes were around 20 and 40 minutes. Similarly, the third scheme based on photocatalytic oxidation with titanium dioxide and UV achieved good treatment with a short time. Indeed, with a HRT of less than 30 minutes, it was reported to achieve a 90% removal of the organics and 6 log removal of the total coliforms (Parsons *et al.*, 2000).

Capital costs of 0.08 US\$/m³ (~0.04 £/m³) and 0.11 €/m³ (~0.07 £/m³) and O & M costs including energy, consumables, sludge treatment and labour of 0.19 US\$/m³ (~0.10 £/m³) and 0.40 €/m³ (~0.27 £/m³) were reported for the electro-coagulation system and the coagulation, sand filter and GAC system respectively. No information on water savings were available, it was therefore not possible to assess the viability of these schemes.

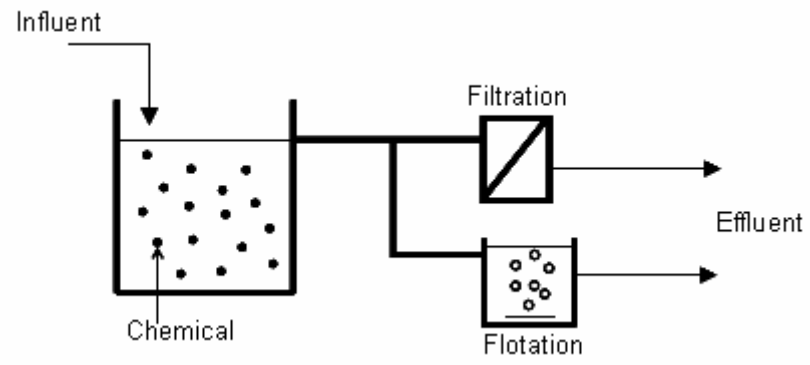

Figure 2.4: Typical flow diagram of chemical technologies with separation by filtration or flotation.

Table 2.6: Simple technologies.

Reference	Location	Building type / Application	Scheme	HRT (flow rate, loading rate)	Performance									
					COD (mg.L ⁻¹)		BOD (mg.L ⁻¹)		Turbidity (NTU)		SS (mg.L ⁻¹)		Total coliforms (cfu/100mL)	
					In	Out	In	Out	In	Out	In	Out	In	Out
March <i>et al.</i> , 2004	Spain	Hotel / Toilet flushing	Screening + Sedimentation + Disinfection	38 hours	171	78	-	-	20	17	44	19	-	-
Brewer <i>et al.</i> , 2000	UK	House / Toilet flushing	Filtration + Disinfection	-	74	11	-	-	2	1	-	-	TNTC	46
Brewer <i>et al.</i> , 2000	UK	House / Toilet flushing	Filtration + Disinfection	-	157	47	-	-	21	7	-	-	2.10 ⁵	13
Hills <i>et al.</i> , 2003	UK	Houses / Toilet flushing	Coarse filtration +Disinfection	-	-	166	-	40	-	40	-	35	-	ND ⁺
Gerba <i>et al.</i> , 1995	USA	House / Toilet flushing and irrigation	Cartridge filter	-	-	-	-	-	21	7	19	8	2.10 ⁸	2.10 ⁶
Mars, 2004	Australia	House / Garden watering	Sedimentation + Trench	-	-	-	-	-	-	-	405	100	-	-
Mars, 2004	Australia	House / Garden watering	Sedimentation	-	-	-	-	-	-	-	310	195	-	-
Mars, 2004	Australia	House / Garden watering	Screening + Trench	-	-	-	-	-	-	-	155	76	-	-

TNTC: too numerous to count.

Table 2.7: Chemical technologies.

Reference	Building type / Application	Scheme	HRT (flow rate, loading rate)	Performance										
				COD (mg.L ⁻¹)		BOD (mg.L ⁻¹)		Turbidity (NTU)		SS (mg.L ⁻¹)		Total coliforms (cfu/100mL)		
				In	Out	In	Out	In	Out	In	Out	In	Out	
Parsons <i>et al.</i> , 2000	UK	Bench scale	Photocatalytic oxidation (TiO ₂ /UV)	<30 minutes	139- 660°	26- 139°	-	-	-	-	-	-	10 ⁶	0
Sostar-Turk <i>et al.</i> , 2005	Slovenia	Pilot scale	Coagulation + Sand filter + GAC	~ 40 minutes	280	20	195	10	-	-	35	<5	-	-
Lin <i>et al.</i> , 2005	Taiwan	Pilot scale	Electro-coagulation + Disinfection	~ 20 minutes (28 m ³ /day)	55	22	23	9	43	4	29	9	5100*	ND*

* as *E. Coli*; ° as TOC.

2.4.2.3 Physical

Physical systems (Table 2.8) can be divided into two sub-categories that are sand filters and membranes. Sand filters have been found to be used alone (Itayama *et al.*, 2004) or in combination with disinfection (Hypes *et al.*, 1975) or with activated carbon and disinfection (CHMC, 2002; Hypes *et al.*, 1975; Prathapar *et al.*, 2006). Used as a sole treatment, sand filters provide a coarse filtration of the greywater. Similarly to the simple technologies previously reviewed, sand filters achieved a limited treatment of the different fractions present in the greywater. To illustrate, Itayama *et al.* (2006) described the treatment of high strength kitchen sink water by a soil filter and reported removal of 67% for the BOD and 78% for suspended solids with respective residual concentrations of 166 and 23 mg.L⁻¹. When coupled with a disinfection stage, only the removal of micro-organisms is obviously improved. Indeed, Hypes *et al.* (1975) in their investigation of the treatment of bath and laundry greywater by an earth filter combined to disinfection with chlorine observed a poor removal of the turbidity and suspended solids with removals of 47 and 16% respectively. However, the system achieved a 4.8-log removal of the total coliforms and a residual concentration of 34 cfu.100mL⁻¹ was measured in the effluent. Finally, sand filters in association with activated carbons and disinfection did not show a significant improvement of the removal of the solids. Indeed, average removals of 61 and 48% were reported for turbidity and suspended solids respectively. Nevertheless, good micro-organisms removals were again reported. Prathapar *et al.* (2006) and Hypes *et al.* (1975) described total coliforms concentrations in the treated effluents of 0 and 4 cfu.100mL⁻¹. Similarly, CMHC (2002) reported a faecal coliforms residual of 8 cfu.100mL⁻¹ after treatment by sedimentation and a multi media filter.

Hypes *et al.* (1975) and Itayama *et al.* (2006) reported hydraulic loading rates of 0.32, 0.24 and 0.086 m³.m⁻².d⁻¹ for three systems based on filtration through soil. These were extremely low hydraulic loading rates in comparison to typical values reported for similar systems for the treatment of other waters and wastewaters. Indeed, Metcalf and Eddy (2003) reported hydraulic loading rates ranging from 115 to 576 m³.m⁻².d⁻¹ for simple, dual and multi-media filters with sand and/or anthracite for the treatment of wastewater. Similarly, Vigneswaran and Visvanathan (1995) reported hydraulic loading rates of 2-5 and 120-360 m³.m⁻².d⁻¹ for slow and rapid sand filter respectively.

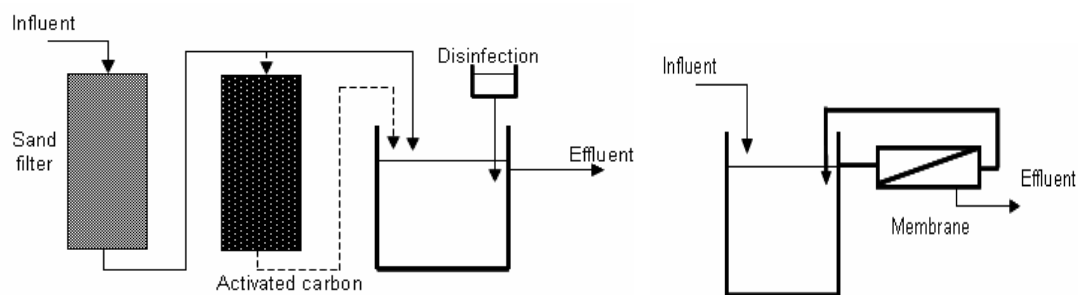

Figure 2.5: Typical flow diagram for physical technologies.

Alternatively, treatment by membranes provided a limited removal of the organics but an excellent removal of the dissolved and suspended solids. To illustrate, removal of up to 100% of the turbidity and suspended solids have been recorded (Ahn *et al.* 1998; Hall *et al.*, 1974; Ramon *et al.*, 2004), and otherwise residual concentrations below 2 NTU for the turbidity and below 10 mg.L^{-1} for the suspended solids were generally observed. In contrast, Birks (1998) and Sostar-Turk *et al.* (2005) reported BOD residuals of 86 and 53 mg.L^{-1} respectively after treatment with ultra-filtration (UF) membranes. However, the pore size of the membrane used will have an important impact on the treatment achieved. For example, Ramon *et al.* (2004) compared the performance of a nano-filtration (NF) membrane with a molecular weight cut off (MWCO) of 0.2 kDa and three UF membranes with MWCO of 30, 200 and 400 kDa for the treatment of shower water. The performance was shown to be better with lower pore sizes especially in terms of organics removal. Indeed, COD removal of 45, 49, 70 and 93% were reported for the membranes with MWCO of 400, 200, 30 and 0.2 kDa respectively. The difference of performance for the turbidity was less obvious with in the same order removal of 92, 94, 97 and 98%. Similarly, Sostar-Turk *et al.* (2005) investigated the use of a UF membrane ($0.05 \mu\text{m}$ pore size) followed by a reverse osmosis (RO) membrane for the treatment of laundry wastewater. The UF membrane decreased the BOD from 195 to 86 mg.L^{-1} corresponding to a removal of 56%. The RO membrane then decreased the BOD from 86 to 2 corresponding to a removal of 98%. A similar trend could be observed for the removal of suspended solids and corresponding values were 49 and 56% for the UF and RO membranes respectively. Very little information was available on the removal of micro-organisms by membranes; however, Jefferson *et al.* (2000) reported an average total coliforms removal of 3 log after filtration of greywater through a micro-filtration membrane revealing limiting action of the membrane for micro-organisms

removal. Similarly, Judd and Till (2000) reported a general breakthrough of *E. Coli* when treating sewage with a micro-filtration membrane. They also found that this phenomenon was enhanced in presence of proteins suggesting that the proteins when adsorbed on the surface of the membrane facilitated the transport of the bacteria through the pores. The main issue when operating membranes is the fouling phenomena. This will have an influence on the operation of the systems and the costs as membrane cleaning will be needed. Interestingly, Sostar-Turk et al. (2005) observed no fouling when treating laundry wastewater with a UF membrane for 150 minutes at a flux of about $130 \text{ L.m}^{-2}.\text{h}^{-1}$ and with a RO membrane for 120 minutes at a flux of about $37 \text{ L.m}^{-2}.\text{h}^{-1}$. Similarly, Ahn et al. (1998) reported no fouling during 12 hours for the treatment of greywater through two UF membranes and one MF membrane at flux around $200 \text{ L.m}^{-2}.\text{h}^{-1}$. These results suggested that no fouling in those conditions occurred at short term. However, Nghiem *et al.* (2006) investigated the fouling UF membranes during synthetic greywater treatment. They observed that the fouling increased linearly with the organic matter (humic acid) concentration. To limit the membrane fouling the membrane stage can be preceded by a pre-treatment such as screening or sand filter for example. To illustrate, Ward (2000) studied a process combining both physical processes, sand filter and membrane, and disinfection for the treatment of a low strength greywater. With a residual of 8 mg.L^{-1} for the BOD and undetectable levels of turbidity and *E. Coli*, the system was good enough to meet the strictest standards for reuse. This good treatment was possible because of the train of processes. Indeed, the sand filter provided a pre-treatment by removing the bigger particles. Reductions of the BOD from 23 to 17 mg.L^{-1} and turbidity from 18 to 17 NTU were observed. The rest of the treatment was then achieved by the membrane and the disinfection.

Table 2.8: Physical technologies.

Reference	Location	Building type / Application	Scheme	HRT (flow rate, loading rate)	Performance									
					COD (mg.L ⁻¹)		BOD (mg.L ⁻¹)		Turbidity (NTU)		SS (mg.L ⁻¹)		Total coliforms (cfu/100mL)	
					In	Out	In	Out	In	Out	In	Out	In	Out
Itayama <i>et al.</i> , 2004	Japan	House / Garden watering	Soil filter	(0.086 m ³ /m ² /day)	271	42	477	166	-	-	105	23	-	-
Hypes <i>et al.</i> , 1975	USA	Pilot scale	Earth filter + Disinfection	2 hours (0.32 m ³ /m ² /day)	-	-	-	-	17	9	549 [~]	460 [~]	2.10 ⁶	34
Hypes <i>et al.</i> , 1975	USA	Pilot scale	Earth filter + Activated carbon + Disinfection	(0.24 m ³ /m ² /day)	-	-	-	-	23	9	500 [~]	394 [~]	1.10 ⁵	4
Prathapar <i>et al.</i> , 2006	Oman	Mosque / Irrigation	Filtration + Activated carbon + Sand filter + Disinfection	(1.3 m ³ /day)	51	35	-	-	13	6	9	4	>200	0
CHMC, 2002	Canada	Apartment building / Toilet flushing	Screening + Sedimentation + Multi-media filter + Ozonation	(1 m ³ /day)	-	-	130	-	82	26	67	21	8870*	8*
Ward, 2000	UK	Pilot scale	Sand filter + Membrane + Disinfection	(4.37 m ³ /day)	65	18	23	8	18	0	-	-	5.10 ³ *	0*
Ramon <i>et al.</i> , 2004	Israel	Bench scale	UF membranes (400kDa)	-	146	80	-	-	18	1.4	-	-	-	-
			UF membranes (200kDa)	-	146	74	-	-	17	1	-	-	-	-
			UF membranes (30kDa)	-	165	51	-	-	24	0.8	-	-	-	-
			NF membranes	-	226	15	-	-	30	1	28	0	-	-
Sostar-Turk <i>et al.</i> , 2005	Slovenia	Pilot scale	RO membrane	-	130	3	86	2	-	-	18	8	-	-
			UF membrane	-	280	130	195	86	-	-	35	18	-	-
Ahn <i>et al.</i> , 1998	Korea	Hotel / Toilet flushing	Membranes	-	64	10	-	-	10	0	-	-	-	-
Hall <i>et al.</i> , 1974	USA	Pilot scale	Coarse filtration + RO + Disinfection	-	-	-	-	-	30	0	102	<10 ⁰	5.10 ⁷	0
Birks, 1998	UK	Pilot scale	UF membrane	-	451	117	274	53	-	-	-	-	-	-

* as *E. Coli*; ~ as Total solids.

2.4.2.4 Biological

A wide range of biological processes have been used for greywater recycling (Table 2.9). Processes such as fixed film reactors (Brewer *et al.*, 2000; McQuire, 2006; Nolde, 1999; Santala *et al.*, 1998; Ward, 2000), rotating biological contactor (Friedler *et al.*, 2004; Nolde, 1999), anaerobic filters (Bino, 2004; Imura *et al.*, 1995), sequencing batch reactor (Shin *et al.*, 1998); membrane bioreactors (Andersen *et al.*, 2001; Friedler, 2005; Goddard, 2006; Laine, 2001; Lesjean and Gnirss, 2006; Liu *et al.*, 2005) and biological aerated filters (BAF) (Birks, 1998; Jenssen *et al.*, 2005; Laine, 2001; Lodge, 2003; Surendran and Wheatley, 1998) were reported in the literature. Biological systems were rarely used individually and when it was the case it was for investigation of the processes at pilot scale (Birks, 1998; Laine, 2001). In most cases, the biological processes were preceded by a physical pre-treatment such as sedimentation (Bino, 2004; Imura *et al.*, 1995; Nolde, 1999) or screening (Friedler *et al.*, 2004; McQuire, 2006, Surendran and Wheatley, 1998) and/or followed by disinfection (Brewer *et al.*, 2000; Gardner and Millar, 2003; Nolde, 1999). They were also combined with membranes in processes such as MBRs (Andersen *et al.*, 2001; Friedler, 2005; Goddard, 2006), sand filter (Gardner and Millar, 2003), activated carbon (Brewer *et al.*, 1998; Surendran and Wheatley, 1998) and constructed wetland (Jenssen *et al.*, 2005).

Biological schemes when installed at full scale were the type of treatment the most commonly used in bigger buildings. Indeed, systems could be found in student residences (Brewer *et al.*, 1999; Friedler *et al.*, 2004; Surendran and Wheatley, 1998), multi-storey buildings (Nolde, 1999; Santala *et al.*, 1998) and stadiums (International Technology Service, 2000; Lodge, 2003). Hydraulic retention times (HRT) ranging from 0.8 hours up to 2.8 days were reported for the biological systems. The higher HRT were observed for systems treating very high strength greywaters such as laundry water (Andersen *et al.*, 2001) and mixed greywater (Bino, 2004) with BOD concentrations of 645 and 300-1200 mg.L⁻¹ respectively. However, HRT in biological system were reported to be on average of 19 hours. Very little information was available on solids retention time (SRT) in the biological systems. Organic loading rates were found to vary between 0.10 and 7.49 kg.m⁻³.day⁻¹ for COD and between 0.08 and 2.38 kg.m⁻³.day⁻¹ for BOD. In details, the average organic loading rate in MBRs was 0.88 kg_{COD}.m⁻³.day⁻¹ which is lower than the typical values of 1.2-3.2

$\text{kg}_{\text{COD}}\cdot\text{m}^{-3}\cdot\text{day}^{-1}$ reported by Stephenson *et al.* (2000) for wastewater treatment. In contrast, the average organic loading rate found for the other systems such as BAF, RBC and bio-films was $1.32 \text{ kg}_{\text{BOD}}\cdot\text{m}^{-3}\cdot\text{day}^{-1}$ which is in the range of $0.3\text{-}1.4 \text{ kg}_{\text{BOD}}\cdot\text{m}^{-3}\cdot\text{d}^{-1}$ reported for these systems (Metcalf and Eddy, 2003).

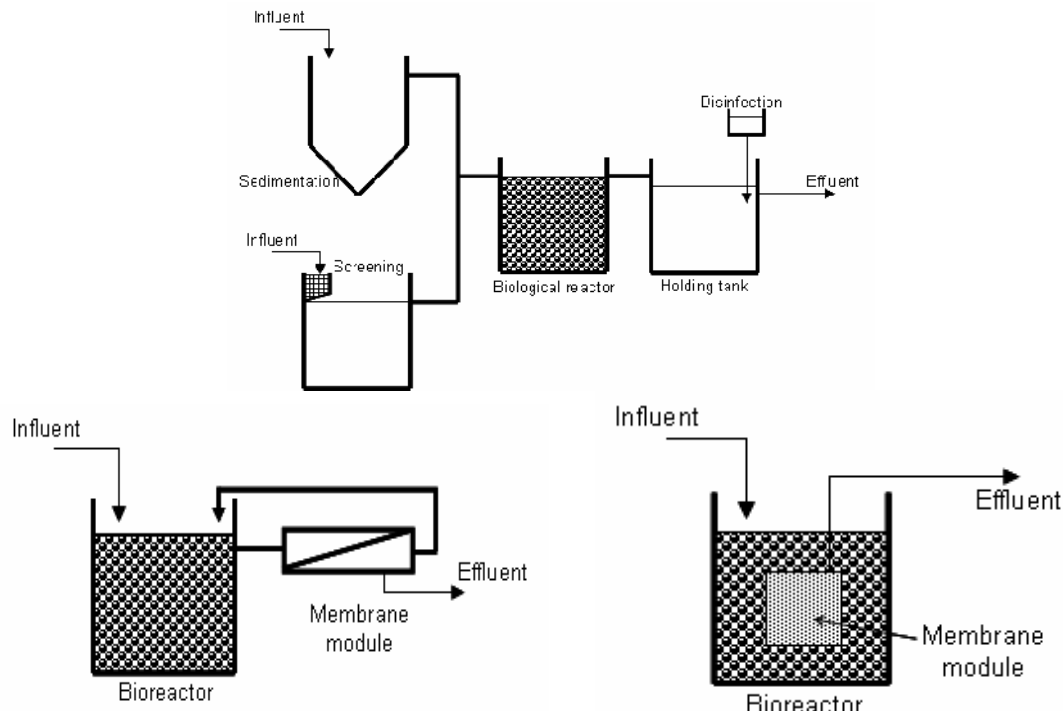

Figure 2.6: Typical flow diagram of biological technologies and submerged and side-stream MBRs.

No matter the number and type of processes included, all schemes with a biological system achieved excellent organic and solids removal. Indeed, all systems but two were reported with residual BOD concentrations below $10 \text{ mg}\cdot\text{L}^{-1}$. Similarly, the turbidity concentrations in the effluents were below 8 NTU for all the systems reviewed. And finally, all schemes but one had suspended solids residual below $15 \text{ mg}\cdot\text{L}^{-1}$. In terms of micro-organisms, once again, the schemes including disinfection achieved excellent removals with on average 5.2 log for faecal coliforms and 4.8 log for total coliforms. Residual concentrations for both faecal and total coliforms were always below $20 \text{ cfu}\cdot 100\text{mL}^{-1}$. Interestingly, MBRs were the only systems to achieve good micro-organisms removal without the need of a disinfection stage. To illustrate average removal of both faecal and total coliforms were reported at 5 log and the corresponding residual concentrations were below $30 \text{ cfu}\cdot 100\text{mL}^{-1}$. Beside, MBRs also achieved excellent removal of the organic and solid fractions with on average

residuals of 3 mg.L⁻¹ for BOD, 3 NTU for turbidity and 6 mg.L⁻¹ for suspended solids (Andersen *et al.*, 2001; Friedler, 2005; Laine, 2001; Lesjean and Gnirss, 2006; Liu *et al.*, 2005). However, Jefferson *et al.* (2000) reported that at small scale the variation in strength and flow of the greywater and potential shock loading affect the performance of biological technologies. To illustrate, Laine (2001) investigated the effect of domestic products spiking on biomass from MBR and reported that products such as bleach, caustic soda, perfume, vegetable oil and washing powder were relatively toxic with EC₅₀ of 2.5, 7, 20, 23 and 29 mL.L⁻¹. Moreover, Jefferson *et al.* (2002) studied the reliability of a BAF and an MBR under intermittent operation of air, feed or both. The performance of the MBR were not affected by interruption of the feed, air or both as the recovery time, time needed by the process to return to its original performance, was always 0 hours. A similar result was found when the feed was stopped for 25 days. However, in comparison, the BAF did not show the same robustness. Although short term interruptions (30 minutes) did not have an effect on the BAF performance, longer cessation of the feed and/or air generated an increase of the effluent concentrations and the recovery times for all the parameters. Indeed, after an interruption of the feed of 8 hours the recovery times were 4, 4, 40 and 48 hours for turbidity, suspended solids, faecal coliforms and total coliforms respectively. Similarly, after the same interruption of the air, the recovery times were 4, 4, 24, 28 and 24 hours for BOD, turbidity, solids, faecal coliforms and total coliforms respectively. The longest recovery times were observed after the interruption of both air and feed simultaneously with 40, 40, 4, 24, 48 hours for BOD, turbidity, solids, faecal coliforms and total coliforms respectively. Finally, none of the parameters had recovered in 48 hours after the interruption of the feed of 25 days.

Again, limited information is available about the costs of the systems. Surendran and Wheatley (1998) reported a capital cost of £3345 for the construction and installation in a 40-student residence of a retro-fit system composed of a buffering tank with screening, an aerated biofilter, a deep bed filter and GAC. The O & M costs were £128/year including the energy, labour and consumables. With water savings of £516/year, the pay back period is 8-9 years. They estimated that if the system was fitted in a new building the capital cost could be reduced to £1720 and then the adjusted pay back period would be 4-5 years. The system comprising a screening filter, a treatment tank with bio-film grown on aggregate balls, a particle filter and UV disinfection unit installed in an individual house and reported by McQuire (2006) was

estimated between 6200 and 8200 Aus\$ (£2514-£3325). Alternatively, Bino (2004) reported a low cost, easy to built system composed of four plastic barrels installed in a 6- person house with a capital cost of 370 US\$ (~£197). No information on the operational costs and water savings were reported for these two schemes. Finally, Gardner and Millar (2003) reported a capital cost of 5500 Aus\$ (£2230) and O & M costs of 215 Aus\$/year (£87/year) for a system based on a septic tank, a sand filter and UV disinfection. However, the water savings of 83 Aus\$/year (£34/year) were not enough to cover the costs. Similarly, Brewer *et al.* (2000) estimated the costs of an aerated bioreactor combined with a sand filter, GAC and disinfection with bromine installed in a student residence at £30000 for the capital cost. But once again, the O & M costs of £611/year exceeded the water savings of £166.

Table 2.9: Biological technologies.

Reference	Location	Building type / Application	Scheme	HRT (flow rate, loading rate)	Performance									
					COD (mg.L ⁻¹)		BOD (mg.L ⁻¹)		Turbidity (NTU)		SS (mg.L ⁻¹)		Total coliforms (cfu/100mL)	
					In	Out	In	Out	In	Out	In	Out	In	Out
International Technology Service, 2000	Japan	Stadium / Toilet flushing	Screening + Sedimentation + Flotation + Rotating filters + Sand filter + Disinfection	(622 m ³ /day)	243	6	336	20	-	-	207	10	-	10
Imura <i>et al.</i> , 1995	Japan	House	Anaerobic filter + Submerged biofilter + Sedimentation + Disinfection	(1,735 m ³ /day)	-	11	-	8	-	-	-	6	-	-
Shin <i>et al.</i> , 1998	Korea	Pilot scale	Sequencing batch reactor + MF hollow fibre membranes	13 hours (1.2 m ³ /day)	79	30	5	5	-	-	185	-	-	-
Liu <i>et al.</i> , 2005	China	Pilot scale	Screening + Membrane bioreactor	3.6 hours	130-322	<40	99-212	<5	146-185	<1	15-50	0	-	ND
Friedler <i>et al.</i> , 2004	Israel	Student flats / Toilet flushing	Screening + Rotating biological reactor + Sedimentation + Sand filter + Disinfection	~18 hours	158	40	59	2	33	1	43	8	6.10 ⁵⁺	1 ⁺
Friedler <i>et al.</i> , 2004	Israel	Student flats / Toilet flushing	Screening + Membrane bioreactor + Disinfection	~18 hours	206	47	95	1	80	0	103	13	3.10 ⁵⁺	27 ⁺
Bino, 2004	Jordan	House / Irrigation	Sedimentation + Anaerobic filter	1-2 days	-	-	300-1200	375	-	-	-	107	-	-
Andersen <i>et al.</i> , 2001	Denmark	Industrial laundry	Membrane bioreactor	2-2.5 days (60 m ³ /day)	1700	50	645	2	-	-	-	-	-	-
Nolde, 1999	Germany	Apartment building / Toilet flushing	Sedimentation + Rotating biological contactor + UV Disinfection	(2.1 m ³ /day)	100-200	-	43-85	<4	-	-	-	-	10 ⁴ -10 ⁵	<10 ⁴
Nolde, 1999	Germany	House / Toilet flushing	Fluidized bed reactor + UV Disinfection	(0.04 m ³ /day)	113-633	-	60-256	<4	-	-	-	-	10 ³ -10 ⁵	<10 ⁴
Santala <i>et al.</i> , 1998	Finland	Apartment building / Toilet flushing	Aerated biofilter + UV Disinfection	-	8000	75	-	-	-	-	-	-	1.10 ⁶⁺	20 ⁺
McQuire, 2006	Australia	House / Toilet flushing, laundry and garden watering	Screening + Biofilm + UV Disinfection	-	-	-	-	9	-	6	-	9	-	0*

Reference	Building type / Application	Scheme	HRT (flow rate, loading rate)	Performance											
				COD (mg.L ⁻¹)		BOD (mg.L ⁻¹)		Turbidity (NTU)		SS (mg.L ⁻¹)		Total coliforms (cfu/100mL)			
				In	Out	In	Out	In	Out	In	Out	In	Out		
Gardner and Millar, 2003	Australia	House / Toilet flushing and outdoor use	Septic tank + Sand filter + UV Disinfection	-	-	-	97	6	-	1	48	3	2.10 ⁵	9	
Jenssen <i>et al.</i> , 2005	Norway	Houses / Irrigation	Septic tank + Aerated biofilter + Constructed wetland	-	-	62	-	<10 [#]	-	-	-	-	-	<100	
Lesjean and Gnirss, 2006	Germany	Pilot scale	Membrane bioreactor	10 hours	493	24	-	-	-	-	7	4	-	-	
Surendran and Wheatley, 1998	UK	Student residence / Toilet flushing	Screening + Aerated biofilter + Deep-bed filter + Activated carbon	-	-	-	-	9	-	1	-	6	-	995	
Birks, 1998	UK	Pilot scale	Biological aerated filter	4 hours (0.4 m ³ /m ² /h)	363	80	131	5	-	-	109	8	-	-	
Brewer <i>et al.</i> , 2000	UK	Student residence / Toilet flushing	Biological reactor + Sand filter + GAC + Disinfection	(263 m ³ /year)	201	62	-	-	212	5	-	-	7.10 ⁵	3	
Laine, 2001	UK	Pilot scale	Biological aerated filter	3.7 hours (0.328 m ³ /day)	128	13	41	4	-	3	52	6	2.10 ⁶	2.10 ⁴	
Laine, 2001	UK	Pilot scale	Submerged membrane bioreactor	13.6 hours (0.071 m ³ /day)	128	7	41	1	-	4	52	4	2.10 ⁶	2	
Laine, 2001	UK	Pilot scale	Membrane aeration bioreactor	0.8 hours (0.225 m ³ /day)	128	17	41	9	-	7	52	13	2.10 ⁶	2.10 ⁴	
Laine, 2001	UK	Pilot scale	Side-stream Membrane bioreactor	2.8 days (0.137 m ³ /day)	273	2	181	1	-	1	58	4	3.10 ⁴	1	
Lodge, 2003	UK	Pilot scale	Biological aerated filter + UF membrane	1.2 hours	80	6	-	-	25	0	52	1	6.10 ⁵	<1	
Ward, 2000	UK	Pilot scale	Biological reactor + Sand filter + GAC	(2.88 m ³ /day)	34	12	21	2	20	1	-	-	2.10 ²	<1	
Lodge, 2003	UK	Arena / Toilet flushing	Biological aerated filter	1.25-5 hours (120 m ³ /day)	84	14	-	-	-	-	31	3	3.10 ⁵	3.10 ³	

⁺ as Faecal Coliforms; [#] as BOD₇.

2.4.2.5 Extensive

Extensive technologies are usually constructed wetlands such as reed beds and ponds (Table 2.10). They have often been fitted with a sedimentation stage before to remove the bigger particles contained in the greywater and a sand filter to remove any particles or media carried by the treated water. The most common type of plants used in reed beds is *Phragmites australis* (Fittschen and Niemczynowicz, 1997; Borin *et al.*, 2004; Frazer-Williams *et al.*, 2005; Shrestha *et al.*, 2001). However, they are considered noxious weed species in Costa Rica so Dallas *et al.* (2004) and Dallas and Ho (2004) investigated alternative macrophyte, *Coix lacryma-jobi*. Alternatively, two studies investigated the use of ranges of plants. Indeed, Frazer-Williams *et al.* (2005) reported the use of *Iris pseudocorus*, *Veronica beccabunga*, *Glyceria variegates*, *Juncus effuses*, *Iris versicolor*, *Caltha palustris*, *Lobelia cardinalis* and *Mentha aquatica* in their GROW system. Similarly, Borin *et al.* (2004) reported a system planted with ten different species (*alisma*, *iris*, *typha*, *metha*, *canna*, *thalia*, *lysimachia*, *lytrum*, *ponyederia* and *preselia*).

The constructed wetlands reported in the literature showed good ability to treat greywater. Indeed, an average BOD residual of 17 mg.L⁻¹ was observed including more than half of the schemes with a residual concentrations below 10 mg.L⁻¹. Similarly, average residual concentration of 8 NTU for turbidity and 13 mg.L⁻¹ for suspended solids were reported. Nevertheless, poor removal of micro-organisms was described. Average removal of 3.6 and 3.2 log were reported for faecal and total coliforms respectively, with residual concentrations generally above 10² cfu.100mL⁻¹ for both indicators. In terms of hydraulics, for the extensive systems reported, HRT was found to vary from a couple of hours up to a year for a scheme composed of three ponds (Gunther, 2000). However, after removing the extremes, the HRT for extensive technologies was on average 4.5 days. Borin *et al.* (2004) compared the performance of two constructed wetlands, one planted with the common reed *Phragmites australis* and the second with a range of ten species. However, no significant difference could be observed between the two systems. To illustrate, concentrations in the effluent of 25.8 and 26.6 mg.L⁻¹ for the BOD, 20 and 30 mg.L⁻¹ for the total suspended solids and 51.2 and 50.5 mg.L⁻¹ for the COD were reported for the systems with the ten species and *Phragmites australis* respectively.

Besides being seen as environmentally friendly technologies, constructed wetlands have been considered as cheap options. Indeed, Dallas *et al.* (2004) and Shrestha *et al.* (2001) described reed beds with capital costs of US\$ 1000 (£531) and US\$ 430 (£229) respectively and very low operating costs.

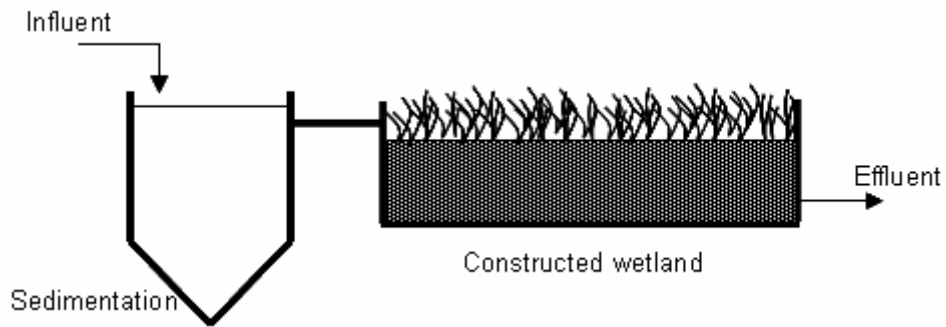

Figure 2.7: Typical flow diagram of extensive technologies.

Table 2.10: Extensive technologies.

Reference	Location	Building type / Application	Scheme	HRT (flow rate, loading rate)	Performance									
					COD (mg.L ⁻¹)		BOD (mg.L ⁻¹)		Turbidity (NTU)		SS (mg.L ⁻¹)		Total coliforms (cfu/100mL)	
					In	Out	In	Out	In	Out	In	Out	In	Out
Frazer-Williams et al., 2005	UK	Pilot scale	Horizontal flow reed bed	2.1 days	452	111	151	51	63	12	87	31	6.10 ⁷	10 ⁴
			Vertical flow reed bed	2 hours batch	452	27	151	5	63	2	87	9	6.10 ⁷	2.10 ⁴
			Constructed wetland	2.1 days	452	139	151	71	63	26	87	19	6.10 ⁷	2.10 ⁶
Gross et al., 2006	Israel	House / Irrigation	Sedimentation + Vertical flow constructed wetland	8 -24 hours	839	157	466	0.7	-	-	158	3	5.10 ⁷ +	2.10 ⁵ +
Gerba et al., 1995	USA	House / Toilet flushing and irrigation	Aquacell + Sand filter	-	-	-	120	4	64	4	40	17	4.10 ⁷	5.10 ⁴
Gerba et al., 1995	USA	House / Toilet flushing and irrigation	Aquacell + Sand filter + Copper dosing + Disinfection	-	-	-	-	-	79	4	36	5	2.10 ⁷	6.10 ⁵
Gerba et al., 1995	USA	House / Toilet flushing and irrigation	Aquacell + Sand filter + Copper and silver dosing +Disinfection	-	-	-	-	-	15	3	19	7	6.10 ⁸	3.10 ⁴
Dallas et al., 2004	Costa Rica	3 Houses / Irrigation	2 Reed beds + Pond	> 10 days (0.755 m ³ /day)	-	-	167	3	96	5	-	-	2.10 ⁸ +	198 ⁺
Dallas and Ho, 2004	Costa Rica	Pilot scale	Trench and plants	4-5 days (0.01 m ³ /day)	-	-	254	13	103	-	-	-	8.10 ⁷ +	2050 ⁺
Shrestha et al., 2001	Nepal	House / Toilet flushing, cleaning and garden watering	Sedimentation + Reed bed	(0.5 m ³ /day)	411	29	200	5	-	-	98	3	-	-
Li et al., 2003	Germany	Houses	Sedimentation + Constructed wetlands	(70 L/p/day)	258-354	-	-	-	-	-	-	-	3.10 ⁵ *	10 ⁴ *
Schonborn et al., 1997	Switzerland	Research centre / Infiltration	Sedimentation + Sand filter + Constructed wetland	-	311	27	130	5	-	-	-	-	-	-
Borin et al., 2004	Italy	University	Reed beds	7 days (0.09 m ³ /day)	151	51	42	26	-	-	25	20	-	-
Fittschen and Niemczynowicz 1997	Sweden	Village / Irrigation	Sedimentation + Reed bed + Sand filter	4 days	361	56	165 [#]	<5 [#]	-	-	-	-	3.10 ⁶	<20
Gunther, 2000	Sweden	Student residence / Toilet flushing	Lime gravel filter + 3 Ponds + Sand filter	~ 1 year	-	-	47 [#]	0 [#]	-	-	-	-	9.10 ⁴	172

* as *E. Coli*; + as Faecal Coliforms; # as BOD₇.

2.4.3 Processes installation and operation

Beside the technologies and their performance, there are specific operational issues to greywater recycling. First of all, a specific collection installation is required. Indeed a dual piping system either retro-fitted or built with the building will be necessary to separate the greywater from the blackwater which will flow directly into the sewer. Greywater is unevenly produced over the day with two main peaks of production, one in the morning between 7 and 10 am and the other in the evening between 6 and 8 pm (Surendran and Wheatley, 1998). Moreover, the treatment systems usually work on a constant flow rate consequently storage of the greywater can be required. However, Dixon *et al.* (1999) reported an increase of the number of micro-organisms in stored bath and laundry greywaters. Indeed, greywater has a relatively high temperature due to the warm water from baths, showers and laundry that favours microbiological growth (Eriksson *et al.*, 2002). It was then suggested to store greywater for no more than 48 hours to avoid health risks (Dixon *et al.*, 1999; Mustow and Grey, 1997). Similarly, the treated effluent will not be used constantly; storage can also be required after treatment. Once again a limited time should be applied to avoid regrowth of the bacteria in the tank. In some cases, a device was fitted to flush the tanks when the greywater had been stored for too long (Brewer *et al.*, 2000). As the main concern when reusing greywater is the health risks, it is important that the users are aware of when the greywater is in use. The use of labels and warning signs has been recommended and also in specific cases the use of dye to identify the reused water (Mustow and Grey, 1997). To illustrate, Brewer *et al.* (2000) reported the use of a coloured disinfectant for greywater reuse for toilet flushing. There are also issues when less recycled greywater is produced than the water demand. To remedy this top-up systems with drinking water have been employed (Brewer *et al.*, 2000; Goddard, 2006; Hills *et al.*, 2003; Hypes *et al.*, 1975; March *et al.*, 2004; Surendran and Wheatley, 1998). Similarly, a possibility to switch to a complete use of main water (Brewer *et al.*, 2000; Santala *et al.*, 1998) can be implemented in case of problems with the system or no greywater available after a long holiday for example.

Most types of schemes reported or an equivalent are now marketed. Indeed, Clearwater Technology produces the Aquacell system based on coarse screening, sedimentation and a membrane bioreactor. Electropure produces a system based on electro-coagulation and flotation similar to the one described by Lin *et al.* (2005).

Everwater and Perpetual water are two systems combining coarse filtration, multi-media filtration (sand and activated carbon) and disinfection with UV and chlorine respectively. Similarly, Garden Saver and Pontos Aquacycle are two processes based on coarse filtration, aerated biological treatment and UV disinfection for the latter. Rootzone Australia Pty Ltd developed a plant based system. Finally, Enviowater, a treatment unit combining bio-film treatment and filtration, and Envirotech, a system based on a septic tank, sand filter and UV disinfection, are the systems reported by McQuire (2006) and Gardner and Millar (2003) respectively (Diaper, 2005).

2.4.4 Conclusions

The review of the standards for greywater recycling and the characteristics of greywaters showed that a technology used for the treatment of greywater for reuse should be able to achieve excellent treatment of the organic, solids and microbial fractions. On the other hand, the review of the greywater recycling schemes reported to date proved that different types of technologies achieved very different performance. Indeed, simple technologies and sand filters have been shown to achieve only a limited treatment of the greywater. Whereas, membranes were reported to provide a good removal of the solids but could not efficiently tackle the organic fraction. Alternatively, biological and extensive schemes achieved good general treatment of greywater with a particularly good removal of the organics. Although less information was available about chemical systems, they showed promising abilities to treat greywater. Micro-organisms removal was good only in schemes including a disinfection stage; however, MBRs were the only systems able to achieve a good microbial removal without the need of disinfection. In conclusion, the best performances were observed within the schemes combining different types of treatment to ensure the good treatment of all the fractions. For instance, Ward (2000) reported the treatment of a low strength greywater with an aerated biological reactor followed by a sand filter, GAC and disinfection with residual concentrations of 2 mg.L⁻¹ for BOD, 1 NTU for turbidity and <1 cfu.100mL⁻¹ for total coliforms. Similarly, Friedler *et al.* (2004) investigated the treatment of bathroom greywater by a rotating biological contactor combined with a sedimentation tank, a sand filter and disinfection with hypochlorite and reported residuals of 0.6 NTU, 5 mg.L⁻¹, 2 mg.L⁻¹ and 1 cfu.100mL⁻¹ for turbidity, suspended solids, BOD and faecal coliforms

respectively. In contrast, MBRs were the only individual technology, although it is a combination of activated sludge and membrane, to be credited with similar performance. To illustrate, Laine (2001) reported residuals of 1 mg.L^{-1} for BOD, 1 NTU for turbidity, 4 mg.L^{-1} for suspended solids and 1 cfu.100mL^{-1} for total coliforms in a greywater treated by a side-stream membrane bioreactor. In the same way, Liu *et al.* (2005) reported effluent concentrations of $<5 \text{ mg.L}^{-1}$ for BOD, <1 NTU for turbidity, and undetectable levels of suspended solids and coliforms after a submerged membrane bioreactor. A review of the HRT applied to each type of systems showed that the three chemical systems worked with very low HRT, below an hour. Then, with an average HRT of 19 hours, the biological proved to be efficient in rather short period of time. Finally, the extensive technologies were the systems working at the highest HRT with an average value of 4.5 days. The shorter HRT observed with biological technologies than with extensive systems for similar performance give an advantage to the biological treatments. Another parameter that will have its importance in the use of a technology is the footprint as space is often limited in urban environments. Systems with biological, chemical or physical technologies have been found to generally have a smaller footprint than extensive technologies. For example, Fittschen and Niemczynowicz (1997) reported a footprint of about 1000 m^2 for a scheme including a sedimentation tank, a reed bed, a sand filter and a pond treating the greywater of a 100-inhabitant village, corresponding to 10 m^2 per inhabitant connected. Similarly, Dallas *et al.* (2004) reported the treatment of the greywater of 7 persons from 3 houses by a sedimentation tank, two reed beds and a pond with a total footprint of about 40 m^2 , corresponding to 5.7 m^2 per person. In contrast, Nolde (1999) reported a system composed of a sedimentation tank, a rotating biological contactor and disinfection installed in the 15 m^2 basement of 70-person multi-storey building, corresponding to 0.2 m^2 per person connected.

From all types of systems reviewed, biological technologies were reported to be the best ones in terms of treatment. However, it has been shown that greywater is variable in strength and flow and spiking of toxic products is possible when people dispose of products such as bleach, washing powder or other cleaning products. And such unsteady conditions have been reported to alter the performance of biological systems, especially at small scale.

Chapter 3 Materials and methods

3.1 Materials

3.1.1 Feed

3.1.1.1 Fedden house site

Wastewater from baths, showers and hand basins was collected from 18 student flats within the Fedden house hall of residence at Cranfield University. The bathrooms were fitted with dual piping and the greywater flowed by gravity into an underground sump. The greywater to be treated was then pumped into a head tank and flowed by gravity in the technologies tested (Figure 3.1).

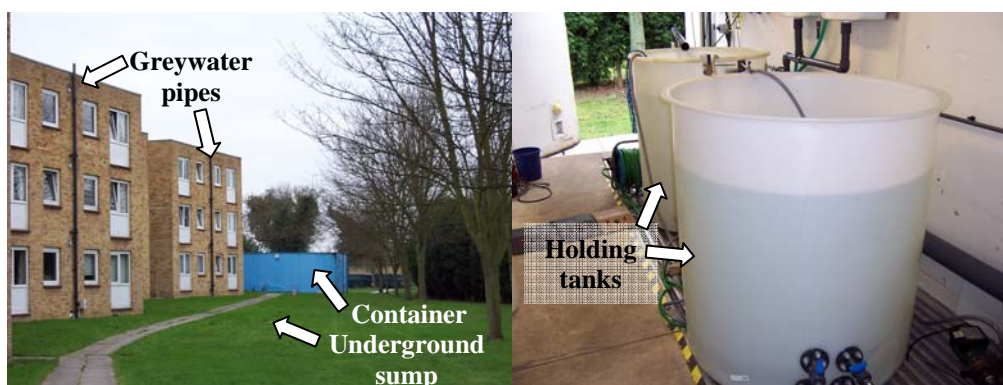

Figure 3.1: Greywater collection system.

The organic strength of the greywater was found to be very low in comparison to typical values reported in the literature (Chapter 2.3). It is not clear why the greywater had such low concentrations of organics as the production rates were at the level expected. However, to enable a range of feed strength to be tested a supplementary dosing system was installed (Figure 3.2). The high strength supplementary solution was a 10% v/v mixture of Tesco Value shampoo in tap water and the real greywater were pumped at fixed intervals (10 minutes every 3 hours) during the day into a second holding tank from which the mixture was pumped to the processes.

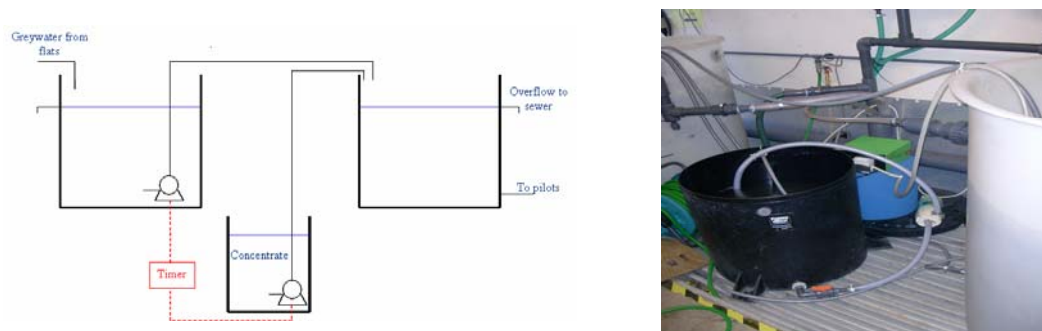

Figure 3.2: High strength dosing system.

3.1.1.2 Showers

For the bench-scale experiments (cf. Chapter 4), shower waters were also collected from two locations. Care was taken to standardise the products used, with respect to their concentration and the duration of the showers, between samples.

3.1.2 Technologies

3.1.2.1 Membrane bioreactor

The membrane bioreactor was located in the container at the Fedden house hall of residence. The MBR (Figure 3.3) consisted of two joint Perspex reactors of 34 litres each. The biomass seeded in the reactors came from an activated sludge system located in the pilot hall at Cranfield University. Each reactor was fitted with two submerged A4 flat sheet Kubota (Japan) membranes. Aeration systems were fitted under the two pairs of membranes to provide scouring and limit the build up of a cake layer on their surface and to provide air to the bacteria. A recirculation loop generated by air lift was integrated on the front of each reactor to provide mixing of the biomass. Taps for sample collection of biomass were situated at the top of the recirculation loops. It was also possible to insert a tubular membrane in the recirculation loops in order to obtain a side stream setup. Finally, the treated water was sucked out through the membranes by a peristaltic pump (505Du, Watson & Marlow, UK). A pressure transducer (RS components, UK) fitted in each permeate line was connected to a computer and the trans-membrane pressure (TMP) permanently recorded.

For the whole duration of the trials in submerged setup, the MBR was run at a single flux of $15 \text{ L.m}^{-2}.\text{h}^{-1}$ which corresponds to a hydraulic retention time (HRT) of 9.7 hours. During the trials with the low strength greywater the solids retention time (SRT) was ~ 68 weeks as only weekly samples were taken for analysis. When the feed was switched to high strength and the mixed liquor suspended solids (MLSS) reached a high level ($\sim 10000 \text{ mg.L}^{-1}$), biomass was wasted and the MLSS then stabilised at $8817 \pm 733 \text{ mg.L}^{-1}$ with a solids retention time (SRT) of 68 days. The air flow rates of the aeration and air lift were set at 5 and 10 L.min^{-1} respectively.

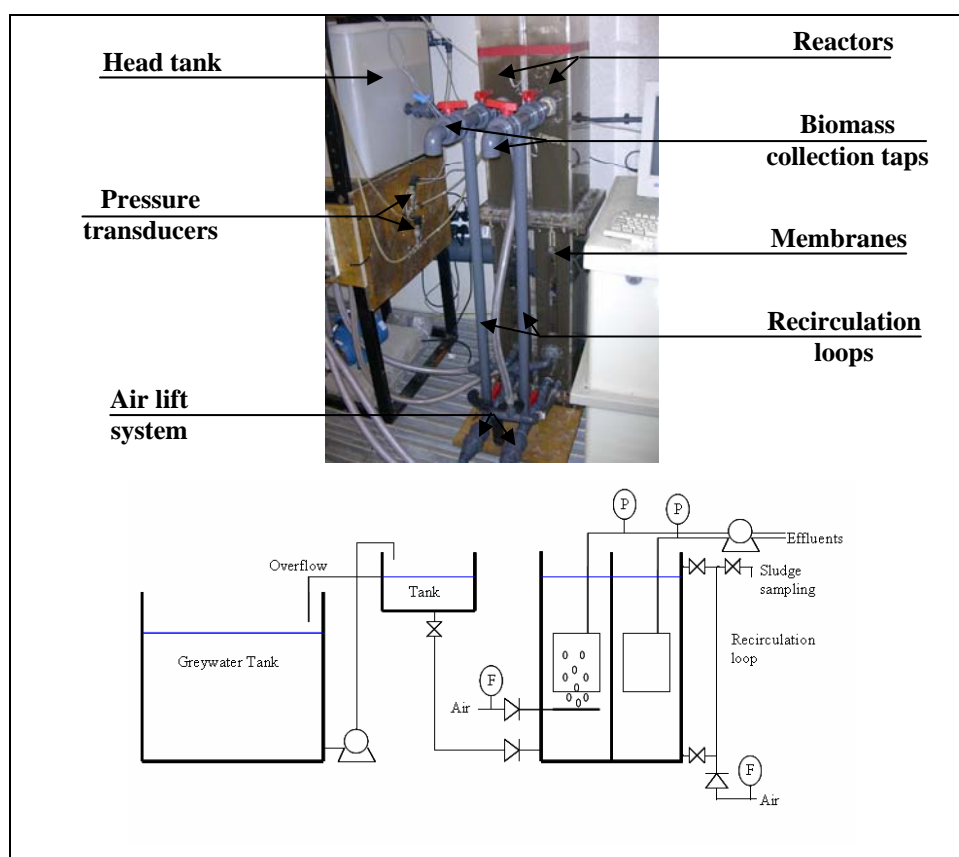

Figure 3.3: Membrane bioreactor.

3.1.2.2 Membrane chemical reactor

The membrane chemical reactor (Figure 3.4) also installed in the container is composed of a 9-litre stainless steel reactor in which a dose of 5 g.L^{-1} of titanium dioxide Hombikat UV-100 (Sachtelbaen Chemie GmbH) is added to the water to be treated. Mixing of the slurry is provided by an aeration system at the bottom of the reactor. For this the air flow rate was set at 5 L.min^{-1} . For the photo-catalytic reaction,

four 25W UVC lamps (Philips) previously cased in glass tubes were dipped into the reactor. The slurry is then recirculated by airlift into a loop containing a tubular membrane. In this case, the air flow rate was set at $10 \text{ L}\cdot\text{min}^{-1}$. Similarly to the MBR, the treated water was sucked out through the membrane by a peristaltic pump (505Du, Watson-Marlow, UK) and a pressure transducer (RS components, UK) was fitted in the permeate line to record the TMP. The performance was investigated for a flux of $15 \text{ L}\cdot\text{m}^{-2}\cdot\text{h}^{-1}$ which corresponds to a hydraulic retention time (HRT) of 3.8 hours. It should be noted that a constant over-foaming was observed during the operation of the MCR. During the start-up of the system for every trial the reactor was filled with tap water and the greywater was let to enter slowly to limit the foaming. However, after the first 4 hours of treatment, the foaming was generally back to its maximum intensity.

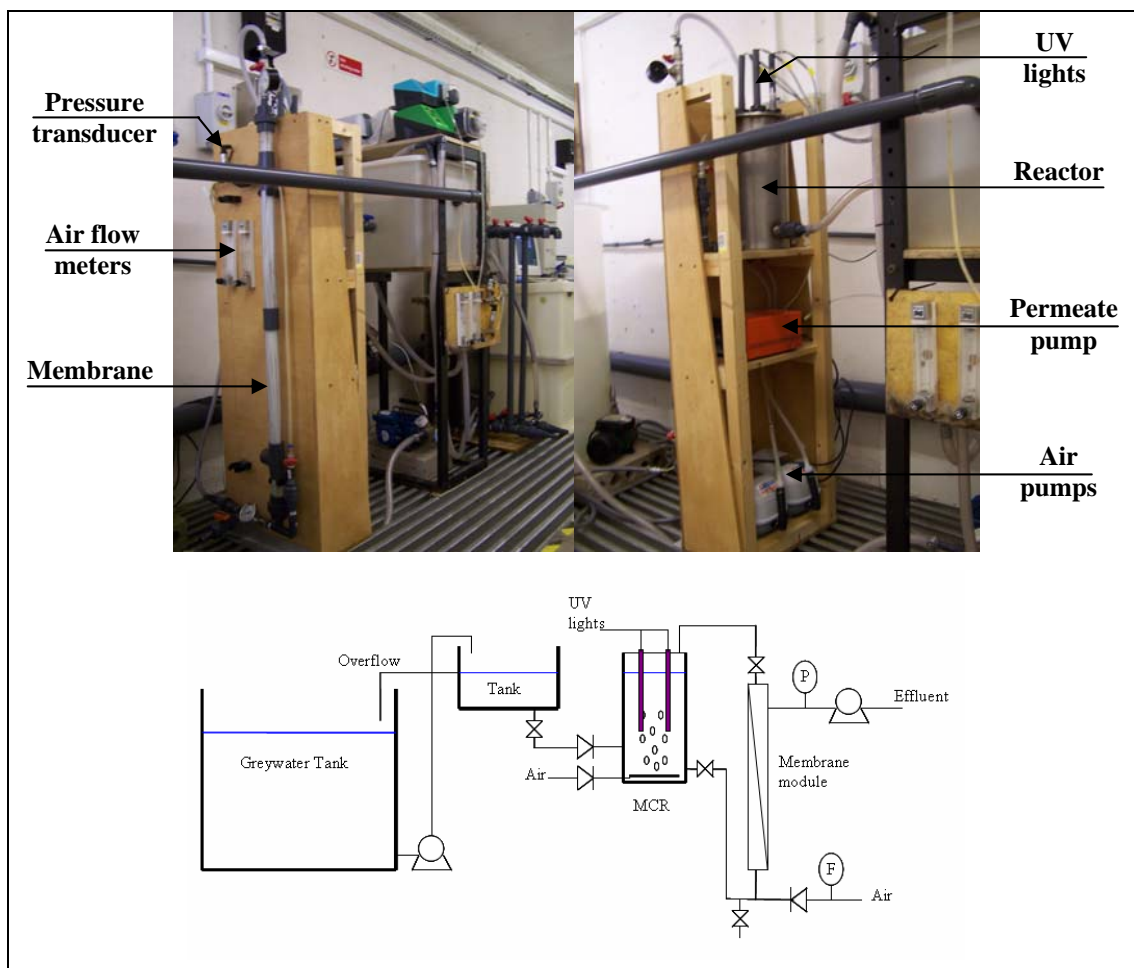

Figure 3.4: Membrane chemical reactor.

3.1.2.3 Bench-scale filtration system

A bench-scale filtration system (Figure 3.5) was used to study the influence of different parameters on titanium dioxide and its properties to foul membranes (cf. chapter 6). This system was composed of a 9-liter PVC tank in which the slurry TiO_2 /greywater was placed. The slurry was then flowed by a centrifugal pump through a cross-flow membrane module (PVC, 28 cm \times 20 cm \times 8 cm) and back to the reactor at a velocity of $0.157 \text{ m}\cdot\text{s}^{-1}$. As seen for the previous systems, the treated water was sucked out through the membrane by a peristaltic pump (505Du, Watson-Marlow, UK) and a pressure transducer (RS components, UK) was fitted in the permeate line to record the TMP. But in this case, because it was a batch system, the permeate was sent back into the tank to avoid any volume loss.

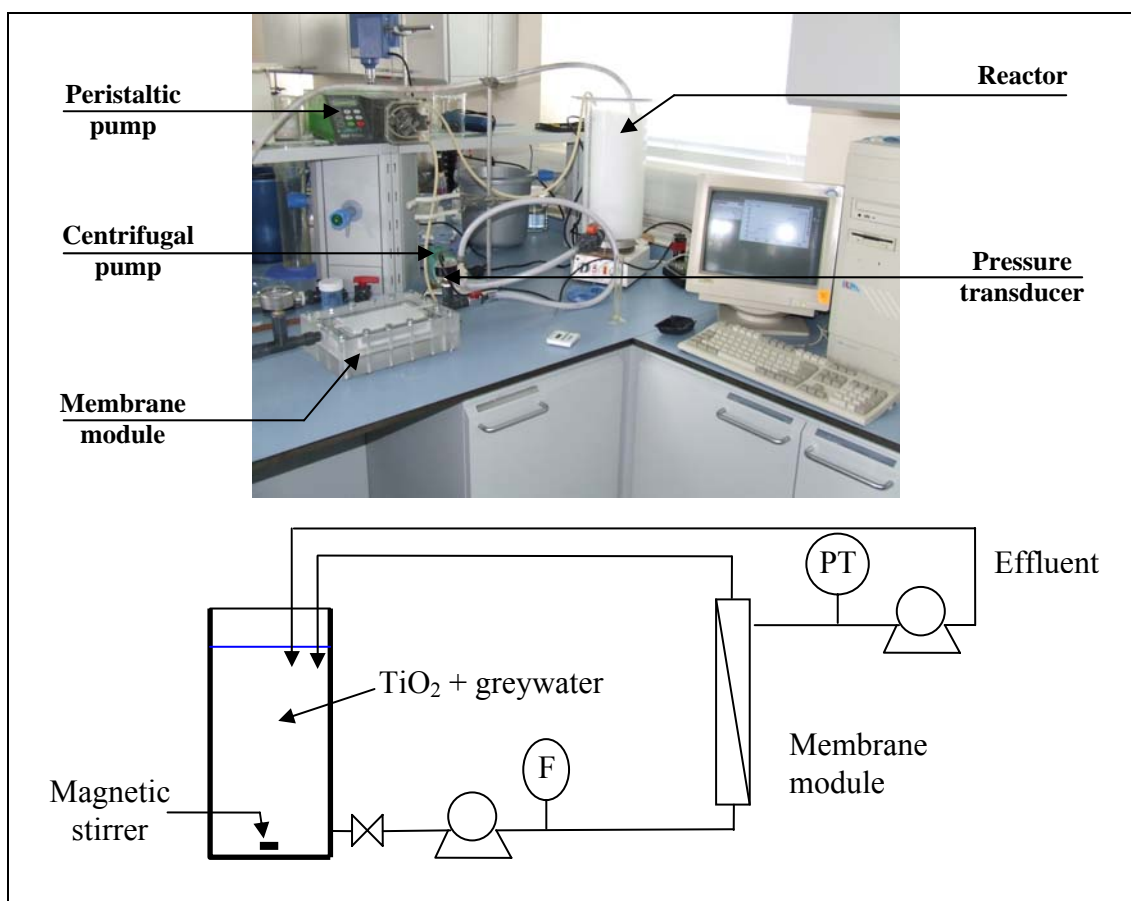

Figure 3.5: Bench-scale filtration system.

3.1.2.4 Membranes specifications and cleaning

In the systems presented above, different types of membranes were used. In the MBR, when used with a submerged setup the membranes were outside-in flat sheet membranes (Figure 3.6a). However for the fouling experiments (cf. chapter 5) inside-out tubular ceramic membranes (Figure 3.6c) were used in the side stream configuration. These membranes were also used for the same study in the MCR as well as an inside-out tubular polymeric membrane (Figure 3.6d). Finally, the membranes used in the bench-scale filtration module (Figure 3.6b) were sheets cut out of A4 flat sheet Kubota membranes to fit the smaller membrane module. The specifications of all these membranes are presented in Table 3.1.

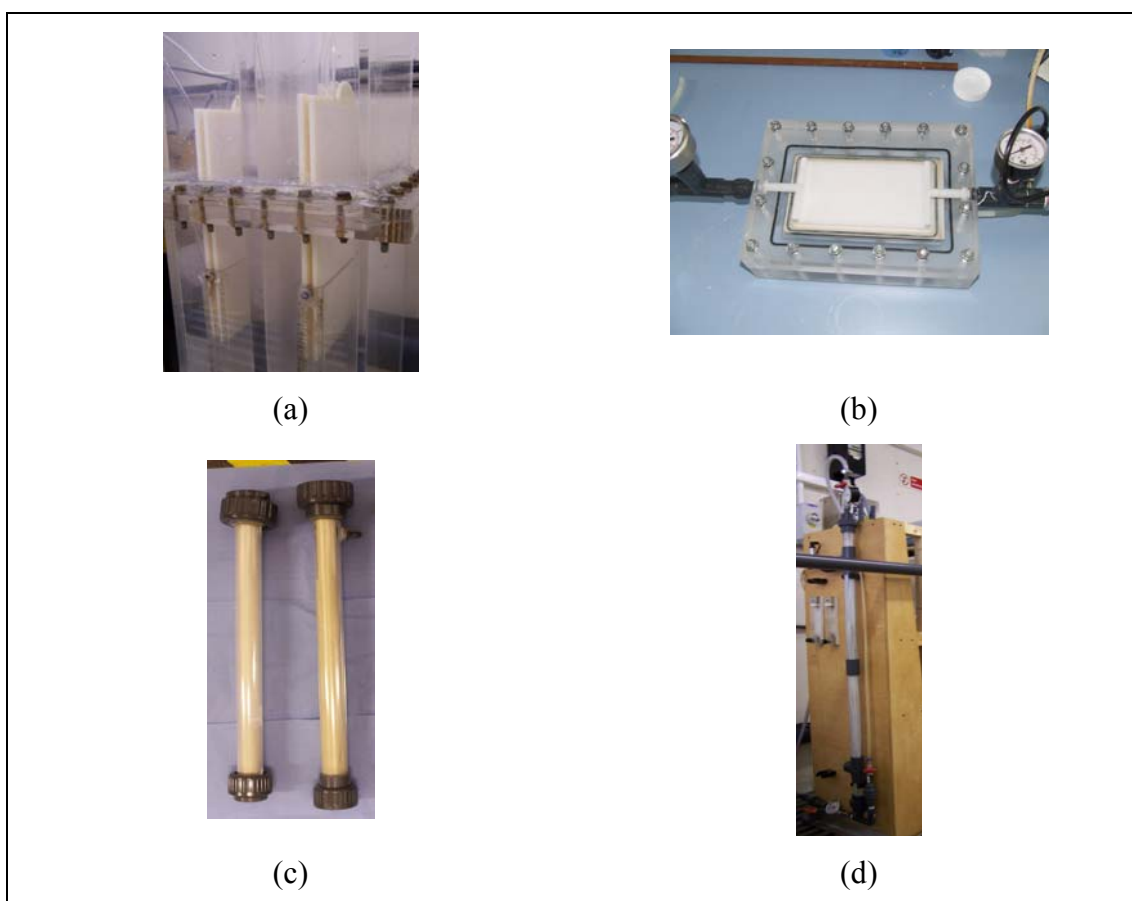

Figure 3.6: Membranes.

Membrane cleaning was carried out after every fouling trial. All tubular membranes and the flat sheet membranes from the bench-scale system were cleaned by the same procedure. They were first rinsed with mains water to remove any superficial cake

and then immersed in a 0.1 M sodium hydroxide solution for 8 hours and in a 0.1M hydrochloric acid solution for another 8 hours. Finally, they were kept in deionised water before being used for the next test. Because of its size, the tubular polymeric membrane was cleaned in situ. Finally, the submerged flat sheet membranes were taken out from the reactors, cleaned with main water and a sponge to remove the biomass agglomerated on their surface and immersed in a 0.6% sodium hypochlorite solution for an hour.

Table 3.1: Membranes specifications.

Membrane type	Length (m)	Number of lumens	Lumens diameter (mm)	Pore size (μm)	Surface area (m^2)	MWCO (kDa)
Flat sheet	-	-	-	0.4	0.116	-
Flat sheet (bench-scale system)	-	-	-	0.4	0.019	-
Tubular ceramic	0.32	7	5	-	0.035	300
Tubular ceramic	0.32	7	5	-	0.035	150
Tubular polymeric	1	10	5	0.05	0.157	-

3.2 Methods

3.2.1 Sampling

Samples for analysis were collected at least weekly. Influent samples were taken in the head tank and effluent samples were collected in the permeate lines of the pilots. Samples of the MBR's biomass were also collected from the tap in the recirculation loop. All the analyses were performed on the same day the samples were taken. Only the samples for dissolved organic carbon (TOC) analysis were kept in a fridge until enough of them were gathered to be analysed.

3.2.2 Analyses

3.2.2.1 Standard analytical procedures

The samples were analysed using the following methods:

- DOC (mg.L^{-1}) was measured using a total organic carbon analyser Shimadzu TOC-5000A (Shimadzu, Milton Keynes, UK).
- Turbidity (NTU) was measured with a turbidimeter Hach 2100N.
- E.coli and total coliforms ($\text{MPN cfu.100mL}^{-1}$) were measured using the method Colilert 18 with quanti-tray 2000 (Idexx, UK) and faecal Enterococci ($\text{MPN cfu.100mL}^{-1}$) using the Enterolert with quanti-tray 2000 (Idexx, UK).
- BOD (mg.L^{-1}) was measured using the procedure 5 day Biochemical Oxygen Demand from The Standard Methods for Examination of Water and Wastewater, 18th Edition, 1992.
- Merck cell tests (Merck (VWR International), Poole, UK) were used for the following tests (Table 3.2):

Table 3.2: Merck cell tests.

Test	Range
Chemical Oxygen Demand (COD)	25-1500 mg.L^{-1}
Ammonium (NH_4^+)	0.6-20.6 mg.L^{-1}
Nitrate (NO_3^-)	0.5-25 mg.L^{-1}
Phosphate (PO_4^{3-})	0.2-15.3 mg.L^{-1}
Total Nitrogen (TN)	0.5-15 mg.L^{-1}

3.2.2.2 Fractionation

The water samples were fractionated into their hydrophobic and hydrophilic components with a method adapted from Malcolm and McCarthy (1992). The raw water was first filtered through a $0.45 \mu\text{m}$ filter and acidified to pH 2 using HCl (1M). The acidified sample was then put through the XAD-8/XAD-4 column pair. The effluent from both columns contained the hydrophilic non-adsorbed fraction (HPI-NA). XAD-8 and XAD-4 columns were eluted with NaOH (0.1M) and the eluates were the hydrophobic acid fraction (HPO-A) and the hydrophilic acid fraction (HPI-A) respectively. The organic content of each fraction was then determined by measuring the DOC.

3.2.2.3 Zeta potential and charge density

Zeta potential was measured using a Malvern Zetasizer (Malvern, UK). The charge density of water samples was determined by using the zeta potential and polydiallyl dimethyl ammonium chloride (PolyDADMAC) (Sigma-Aldrich, UK). The samples were placed in a 1-litre beaker and stirred. A 0.1% solution of PolyDADMAC was dosed into the solution, the pH adjusted to 7 and the zeta potential measured until the point of zero charge or iso-electric point (i.e.p.) was reached. The charge density of the samples (meq.g^{-1} DOC) was then deduced from the amount of PolyDADMAC (charge density: 6.2meq.g^{-1}) used (Sharp *et al.*, 2004).

3.2.2.4 Biomass characterisation

- Mixed liquor suspended solids (MLSS) and mixed liquor volatile suspended solids (MLVSS):

A known volume of biomass (V) was filtered through a pre-weighed (w_1) glass fibre filter paper (Whatman GC/F 70 mm diameter, Fisher Scientific Ltd, UK). After filtration, the filter paper with the solids was placed overnight in an oven set at 105°C , then cooled in a desiccator and weighed again (w_2). MLSS was then calculated as follows:

$$MLSS(g/L) = \frac{w_2 - w_1}{V} \quad \text{Equation 3.1}$$

After, the filter paper with the solids was placed in a furnace set at 500°C for 4 hours. After cooling in desiccator, the filter paper was weighed again (w_3) and the MLVSS was calculated as follows:

$$MLVSS(g/L) = \frac{w_2 - w_3}{V} \quad \text{Equation 3.2}$$

- Particle sizes:

The biomass flocs sizes were measured with a Malvern Mastersizer 2000 particle analyser (Malvern Instruments Ltd, Worcestershire, UK). The particles of biomass were dispersed in deionised water and circulated from the stirred reservoir through the measurement cell. The optical parameters were set at default (refractive index: 1.52 and absorption: 0.1) appropriate for the majority of naturally occurring samples.

Three measurement of each sample were performed and the average value of the median particle size d_{50} (μm) was taken.

- Extracellular polymeric substances (EPS) and soluble microbial products (SMP) fractions:

A 100 mL biomass sample was centrifuged at 5000 rpm for 5 minutes. The supernatant was then filter through a 0.2 μm filter. The filtrate was the soluble microbial products (SMP) fraction. 100 mL of DI water were then added to the bottle containing the biomass. After the bottle was gently shaken to loosen the biomass from the bottle wall, it was placed in an oven at 105 °C for 1 hour. Once the bottle was allowed to cool down to room temperature, the sample was centrifuged at 7500 rpm for 5 minutes. The supernatant filtered through a 0.2 μm filter was the extracellular polymeric substances (EPS) fraction. The concentrations of proteins and carbohydrates in each fraction were then measured by colorimetric methods.

For the carbohydrates concentration measurement, 0.4 mL of the sample was added to 0.4 mL of 5% (w/w) phenol and 2 mL of concentrated sulphuric acid. A blank was prepared with DI water instead of the sample. The carbohydrates concentration was then measured by measuring the UV absorbance at 480 nm on a Jenway 6505 S UV/VIS spectrophotometer. Similarly, for the proteins concentration measurement, 0.2 mL of the sample was added to 2.2 mL of Biuret reagent (Sigma, UK) and 0.1 mL of Folin and Ciocalteu's Phenol reagent (Sigma, UK). A blank was prepared with DI water instead of the sample. The proteins concentration was also measured by measuring the UV absorbance but at 595 nm.

- Capillary suction time (CST):

The CST was measured using a Triton CST filterability tester (model 2000, Triton Electronics Ltd, UK) and standard filter papers (part No 815095) supplied by Triton Electronics. A 6.4 mL of biomass placed in the reservoir and water was extracted from the biomass by capillary suction. The timer switched on when the water passed the first contact (C1) and stopped when the liquid passed the second (C2) (Figure 3.7). The time obtained for the water to pass from the first to the second contact is defines as the CST which provides a relative measure of the sludge dewaterability.

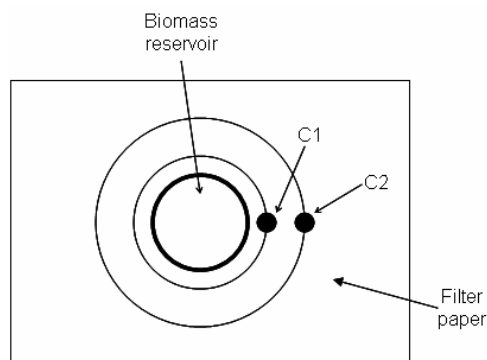

Figure 3.7: CST tester.

3.2.3 Fouling determination

3.2.3.1 Flux step method

To assess fouling of the membranes at short term, the flux step method as described by Le Clech *et al.*, (2003) was used. At set conditions, the permeate flux was increased by steps for a duration of 15 minutes and the TMP recorded (Figure 3.8). When no fouling occurs the TMP should not vary with the time; in contrast, when fouling start building up on the membrane's surface the TMP will increase with the time. The fouling was then reported in terms of fouling rates and membrane permeability.

3.2.3.2 Sustainable flux

For the investigation of the fouling of the membranes over longer time period, sustainable flux tests were carried out. The sustainable flux test consisted in setting the wanted flux for the membrane to be tested and recording the TMP. The TMP should stay relatively steady until fouling occurs. The time from which the TMP starts increasing sharply is called the critical time. The critical time is an indication of the duration for which the system can be run at set conditions before cleaning of the membrane is required.

3.2.4 MIEX[®] and coagulation

3.2.4.1 MIEX[®]

Magnetic Ion Exchange (MIEX[®]) (Orica, Australia) resin was specially designed to remove dissolved organic carbon (DOC) from potable water. In contrast to traditional ion exchange resins, MIEX[®] has a magnetic component in its structure which facilitates agglomeration and settling. Moreover, with an average particle size of 180 μm , 2 to 5 times smaller than traditional ion exchange resins, MIEX[®] has a high surface area for adsorption. It is designed to be added to the water as slurry in a mixed reactor what increase the contacts with the organics present into the water and then reduce the contact time compare to a fixed-bed set up (Boyer and Singer, 2005). MIEX[®] resin was prepared by measuring the required dose in measuring cylinders and allowed to settle for approximately one hour, and then adjusted with a plastic pipette and allowed to settle for another half hour. 1 litre of the water to be tested was placed on a PB900 jar tester (Phipps and Bird, Virginia USA) which was set to 150 rpm. The resin was shaken in the measuring cylinder and added to the water sample, and the residual was rinsed into the jar with deionised water. At the end of each test, the treated water was filtered through 0.45 μm glass fibre filter papers.

3.2.4.2 *Coagulation*

For the coagulation test, 1 litre samples of greywater were tested. Two speeds were used:

- A rapid mix at 200 rpm for 90 seconds, time during which the coagulant, either ferric sulphate (Ferrisol XL, EA West) or aluminium sulphate (Kemira Chemicals, Harrogate, UK) was dosed in the jar and the pH adjusted to the chosen value (4.5, 6 and 7).
- The sample was then flocculated for 15 minutes at 30 rpm and allowed to settle for an additional 15 minutes before analysis.

Finally, both tests were coupled with the MIEX[®] resin prepared as explained above and added to the water, at the optimum conditions found under the previous tests. The jar tester was set up at 150 rpm for 10 minutes, after a settling period the treated water was filtered. The filtrate then underwent the coagulation experiments as described before for a range of concentrations and pH.

3.2.5 Adsorption

A range of concentrations of each adsorbent (Table 3.3) was added to the greywater to be treated (100 mL) in conical flasks (250 mL). The mixture was stirred at room temperature for 24 hours. After filtration, the treated samples were analysed.

Table 3.3: Adsorbents doses.

Adsorbent	Doses (g)				
High Activity Carbon (HAC)	0.01	0.05	0.10	0.50	1.00
Medium Activity Carbon (MAC)	0.01	0.05	0.10	0.50	1.00
Activated Alumina (AA)	0.1	0.5	1.0	2.5	5.0
Ferric Hydroxide (FeOOH)	0.1	0.5	1.0	2.5	5.0
Titanium Dioxide (TiO ₂)	0.1	0.5	1.0	2.5	5.0

3.2.6 Kinetics

3.2.6.1 *Bio-kinetics*

The bio-kinetic parameters were obtained using the respirometry method (Rozich and Gaudy, 1992). Before the tests the biomass from the MBR was washed with BOD dilution water containing 1 mL of FeCl₃, MgSO₄ and CaCl₂ solutions and a sulphate buffer per litre of distilled water to remove residual substrate. The cells of the respirometer (Aerobic Respirometer, Co-ordinated environmental services Ltd, UK) were then filled with 20 mL of the washed biomass and 30 mL of different concentrations of the substrate. The MBR feed was used as the substrate and diluted with deionised water to achieve the different concentrations. The initial MLVSS and COD concentrations were measured before placing the cells in the respirometer. The cells were stirred and kept at 25°C for the duration of the experiment. The oxygen consumption was measured every minute for 20 hours.

When studying the kinetic of biological systems there are important parameters to determine. These parameters are the yield coefficient, Y , the maximum specific growth rate, μ_{\max} and the half-saturation constant or shape factor of the Monod equation, K_s . The yield coefficient, Y , which is defined as the mass of biomass

produced per unit mass of substrate removed ($\text{mgMLVSS.mgCOD}^{-1}$) can be determined by using the parameters and performance of the pilot plant. Indeed, it was calculated using the pilot plant MLVSS growth rate and the COD removal following the Equation 3.3 (Rozich and Gaudy, 1992).

$$Y = \frac{\Delta X}{S_{\text{influent}} - S_{\text{effluent}}} \quad \text{Equation 3.3}$$

The oxygen consumption data were converted to biomass growth using the equation 3.4 (Rozich and Gaudy, 1992).

$$X_t = X_0 + \frac{O_2 \text{ uptake}}{\frac{1}{Y} - O_x} \quad \text{Equation 3.4}$$

Where:

O_2 uptake = oxygen consumed by the biomass (mg.L^{-1});

X_t = MLVSS concentration at time t (mg.L^{-1});

X_0 = initial MLVSS concentration (mg.L^{-1});

Y = yield coefficient ($\text{mgMLVSS.mgCOD}^{-1}$);

O_x = unit COD of the cell mass ($\text{mgCOD.mgMLVSS}^{-1}$).

Rozich and Gaudy (1992) reported that the unit COD of the cell mass, O_x , should be close to $1.42 \text{ mgCOD.mgMLVSS}^{-1}$. It was then decided to use this value in the present investigation.

The specific growth rate, μ , can be calculated by inserting Equation 3.4 in Equation 3.5:

$$\mu = \frac{\ln(X_t / X_0)}{t - t_0} \quad \text{Equation 3.5}$$

Where:

μ = specific growth rate (h^{-1});

$t = \text{time } t \text{ (h)}$;

$t_0 = \text{time } 0 \text{ (h)}$.

The specific growth rate can also be obtained graphically by plotting $\ln(X_t)$ vs. time and measuring the slope of the different curves obtained for each substrate concentrations.

Finally, the maximum specific growth rate, μ_{\max} , and the half-saturation constant, K_s , can be determined by fitting the values of μ and S obtained from the experiments in the Monod equation (Equation 3.6):

$$\mu = \frac{\mu_{\max} S}{(K_s + S)} \quad \text{Equation 3.6}$$

μ_{\max} and K_s can in fact be obtained graphically by plotting S/μ vs. S . Indeed, by adapting the Monod equation into Equation 3.7, the slope will be $1/\mu_{\max}$ and the intercept will be K_s/μ_{\max} .

$$\frac{S}{\mu} = \frac{S}{\mu_{\max}} + \frac{K_s}{\mu_{\max}} \quad \text{Equation 3.7}$$

3.2.6.2 Kinetic of catalytic reactions

The kinetic of the catalytic reaction occurring during the treatment of greywater by titanium dioxide with UV light was studied in terms of organic removal (Dissolved organic carbons, DOC). For this, a concentration of 5g.L^{-1} of titanium dioxide was added to the samples of greywater at different organic strength in conical flasks. The slurries were placed under UV light and agitated for the duration of the experiment. Samples were taken at different times and their DOC content was measured.

Several studies reported that kinetics of catalytic reaction were better described by the Langmuir-Hinshelwood kinetics (Chen and Jenq, 1998). The Langmuir-Hinshelwood oxidation rate is written as follow (Equation 3.8):

$$-r = -\frac{dC}{dt} = \frac{kKC}{1 + KC} \quad \text{Equation 3.8}$$

Where:

r = oxidation rate ($\text{mg.L}^{-1}.\text{min}^{-1}$);

C = concentration of the reactant (mg.L^{-1});

t = illumination time (min);

k = reaction rate constant ($\text{mg.L}^{-1}.\text{min}^{-1}$);

K = adsorption coefficient of the reactant (L.mg^{-1}).

Equation 3.8 can be transformed into Equation 3.9:

$$-\left(\frac{1}{C} + K\right)dC = kKdt \quad \text{Equation 3.9}$$

Integration of Equation 3.9 yields Equation 3.10:

$$\ln\left(\frac{C_0}{C}\right) + K(C_0 - C) = kK(t - t_0) \quad \text{Equation 3.10}$$

For $t_0 = 0$ and when C_0 is very small, Equation 3.10 can be simplified into Equation 3.11:

$$\ln\left(\frac{C_0}{C}\right) = kKt = K't \quad \text{Equation 3.11}$$

Therefore, the apparent first order rate constant K' can be determined by plotting $\ln(C_0/C)$ vs. t .

3.2.7 Dosing experiments

The aim of these experiments was to investigate the influence of spiking of some household products on the biological and chemical systems.

3.2.7.1 *Biological*

The influence of the spiking of products in the biological system was studied in terms of toxicity to the biomass. The experiments were then carried out in an 11-cell respirometer (Aerobic Respirometer, Co-ordinated environmental services Ltd, UK). In each cell was poured 20 mL of biomass from the MBR previously washed with BOD dilution water, 30 mL of greywater and 10 mL of different concentrations of a solution of the product dosed or deionised water for the control. The cells were then placed in the respirometer and the oxygen consumption recorded every minute for 20 hours. The cells were stirred and kept at 25°C for the duration of the experiment.

3.2.7.2 *Chemical*

The same concentrations of the products as the ones used with the biological system were tested on the chemical system. In this case, the influence of dosing of the products was assessed on the performance of the chemical system to remove organic carbons (TOC). 200-mL samples composed of greywater and different concentrations of the products were added to 1 gram of titanium dioxide in stirred flasks and placed under a UV light for 24 hours. The TOC was measured before and after treatment by photocatalysis and the removals were compared to the one achieved with only greywater.

3.2.8 *Microtox[®]*

To investigate the toxicity of household products on bacteria the Microtox[®] test (Microbics M500 toxicity analyser, Azur Environmental, UK) was used. For this test, different concentrations of products to be tested are added into cells containing bacteria. The bacteria used are marine luminescent bacteria (*Vibrio fischeri* NRRL B-11177) that produce light as by-product of their cellular respiration. Inhibition of the cellular activity by a toxic product will generate a decrease of the respiration and consequently a decrease of the luminescence rate. The Microtox[®] analyser measures the luminescence before and after the dosing of the range of concentrations of the product and determines the median effective concentration EC_{50} , the concentration required to inhibit 50% of the test organisms. It should be noted that the toxicity can also be quantified using the median inhibitory concentration (IC_{50}) or the median lethal concentration (LC_{50}).

Chapter 4 Chemical solutions for greywater recycling

4.1 Coagulation and MIEX[®]

4.1.1 Greywaters characteristics

For the investigation of the performance of coagulation and MIEX[®] for greywater recycling, two greywaters were used, a mixed greywater collected from the bathrooms of the Fedden house hall of residence at Cranfield University and a shower greywater. The two sources of greywater tested in the current investigation varied considerably in terms of their organic concentration (Table 4.1). For instance, the BOD and COD of the two sources were 39 ± 17 and 144 ± 63 mg.L⁻¹ for the mixed source and 166 ± 37 and 575 ± 98 mg.L⁻¹ for the shower water. Published greywater strengths indicate that the water strength can vary considerably from one scheme to the next but normally fall within the range 50 to 300 mg.L⁻¹ BOD (Jefferson *et al.*, 2004). Comparison of the organic parameters indicates that the COD to BOD ratio is approximately 3.5 in both waters studied in the current investigation. This compares to 2.2 for typical domestic sewage and 3-10 for final effluent suggesting greywater contains more non biodegradable material than sewage (Metcalf and Eddy, 2003). This supports the case for investigation of non biodegradable treatment options such as chemical processes. The study of parameters commonly used when describing coagulation showed DOC concentrations of 12 ± 4 and 56 ± 7 mg.L⁻¹ for the mixed and shower sources respectively. The concentration found for the mixed source is equivalent to the one observed for a potable water source with a high concentration of natural organic matter (NOM) (Ratnaweera *et al.*, 1999) whereas the shower source represents a very high strength and consequently high coagulant doses are expected. The specific UV absorbance (SUVA) was measured between 2.5 and 3.5 L.mg⁻¹.m⁻¹ for the mixed greywater and between 1.5 and 2.5 L.mg⁻¹.m⁻¹ for the shower water. It has been shown that waters with high SUVA (>4 L.mg⁻¹.m⁻¹) such as natural waters (Sharp *et al.*, 2006) have a relatively high content of hydrophobic and high molecular weight (MW) organic matter (Karanfil *et al.*, 2002; Edzewald and Tobiason, 1999). In contrast, waters with low SUVA (<3 L.mg⁻¹.m⁻¹), such as the two greywaters presented here and secondary treated effluent (Hu *et al.*, 2003; Jarusutthrak *et al.*,

2002), contain mainly hydrophilic and low MW materials. This was corroborated by the results obtained by the XAD resin fractionation process. Indeed, both greywaters were found with a higher content of hydrophilics (60-70%) than the reported for natural water (25-41 %) or similar to the one found for river water sources with a high content of sewage effluent in which the hydrophilic components can contribute around 40-60% of the total organic strength in the water (Parsons and Jefferson, 2006).

In terms of electrical characteristic, the colloids were negatively charged in natural pH environments with a zeta potential of -13.2 ± 0.7 and -19.4 ± 3.1 mV for the mixed and shower waters respectively. The corresponding charge densities of the two waters 0.6 ± 0.1 and 2.4 ± 0.1 meq.g_{DOC}⁻¹ revealed that the fresher shower water contained considerably more charged components compared to the mixed source. Comparison with other species commonly coagulated suggested that the colloids in greywater exert a relatively low charge demand to the water per unit of organic material. For instance, reported values of other systems are around 5 meq.g_{DOC}⁻¹ for NOM (Kam and Gregory, 2001; Sharp *et al.*, 2006), 0.1-3.2 meq.g_{DOC}⁻¹ for algal organic matter (Henderson *et al.*, 2006) and 0.1-1 meq.g_{DOC}⁻¹ for inorganic colloids such as kaolin (Edwald, 1993). Interestingly, reported charge densities for the hydrophilic fraction within NOM are 1.0 ± 0.6 meq.g_{DOC}⁻¹ which is in between the values obtained for greywater. The charge concentrations determined from the charge densities were 0.0072 meq.L⁻¹ and 0.134 meq.L⁻¹ for the mixed source and shower water respectively. A comparison to the levels found for NOM, 0.02-0.05 meq.L⁻¹ (Sharp *et al.*, 2006), showed that the mixed source water represents relatively low coagulant demand in opposition to the shower water with a coagulant demand 25-70 times greater than a typical NOM rich water. Calculation of the neutralising charge of coagulants based on speciation data (Jiang and Graham, 1998) revealed that iron based coagulants provide 35.5, 30.7, 12.6, 1.7 meq.g_{Fe}⁻¹ at pH values of 4, 5, 6, 7 respectively. Similarly, over the same pH values aluminium coagulants provide 104.5, 45.8, 12.5, 1.9 meq.g_{Al}⁻¹. Hence the charge neutralising capacity of both coagulants is greater under acidic conditions. To illustrate, the neutralising capacity reduces by a factor of 8 and 3 for alum and iron respectively as the pH increases from 4 to 6. Interestingly, at near neutral pH levels as found in greywater the neutralising capacity of both systems is very similar. Differences in the neutralising capacity of each

coagulant are based on the weight of the metal ion such that conversion to a meq basis reveals both systems to provide almost identical capacities (Sharp *et al.*, 2006).

Table 4.1. Characteristics of the greywaters tested compared to wastewater and natural water.

	Greywaters		Wastewater	Natural water
	Mixed (low strength)	Shower (high strength)	Metcalf and Eddy, 2003	Sharp <i>et al.</i> , 2006
BOD (mg.L ⁻¹)	39 ± 17	166 ± 37	110 - 450	-
COD (mg.L ⁻¹)	144 ± 63	575 ± 98	250 - 800	-
COD/BOD	3.7	3.5	1 - 3	-
DOC (mg.L ⁻¹)	12 ± 4	56 ± 7	80 - 260	7 - 14
Turbidity (NTU)	35 ± 16	42 ± 9	-	-
TN (mg.L ⁻¹)	7.6 ± 3.0	16.4 ± 3.0	20 - 70	-
PO ₄ ³⁻ (mg.L ⁻¹)	0.5 ± 0.2	1.3 ± 0.1	-	-
NH ₄ ⁺ (mg.L ⁻¹)	0.7 ± 0.7	1.0 ± 0.3	-	-
NO ₃ ⁻ (mg.L ⁻¹)	3.9 ± 1.6	7.5 ± 1.2	0	-
pH	6.9 ± 0.3	7.5 ± 0.2	-	-
Charge density (meq.g ⁻¹ DOC)	0.6 ± 0.1	2.4 ± 0.1	-	5 - 15
SUVA (L.mg ⁻¹ .m ⁻¹)	2.5 - 3.5	1.5 - 2.5	1.5 - 2.7*	5
Hydrophobic fraction (%)	40	30	-	59 - 75

* In secondary treated effluent (Hu *et al.*, 2003; Jarusutthrak *et al.*, 2002).

4.1.2 Coagulation

Both greywater sources were trialled under ranges of coagulant doses and pH and the results presented in terms of BOD as it is the most common parameter for standards for urban reuse (Figure 4.1). In the mixed greywater, the residual BOD concentration remained quite constant over the range of doses tested with values between 1 and 5 mg.L⁻¹ for alum and between 1 and 7 mg.L⁻¹ for ferric corresponding to removals ranging between 68 and 99%. The results obtained seemed independent of pH over the range tested. In contrast, in the shower source the BOD residual decreased as a function of dose (Figure 4.1) until it reached a plateau at around 24 and 30 mg.L⁻¹ for alum and ferric respectively. The corresponding removals were between 79 and 85%. In this case, the systems appeared to be more pH dependant and better efficiency was observed under acidic conditions although this was more pronounced in the case of

alum than ferric. For example, when coagulating with 18 mg.L^{-1} of alum the residual BOD was 69.0 , 38.7 and 20.3 mg.L^{-1} at pH 7 , 6 and 4.5 respectively. This had also an impact on the dose required to reach the plateau as in the case of alum the minimum dose necessary was 24 , 28 and 32 mg.L^{-1} for pH values of 4.5 , 6 and 7 respectively. The lower doses required at lower pH are consistent with the data found in the literature. Indeed, optimum coagulation results with alum and ferric have been obtained in pH 4.5 - 6 (Sharp *et al*, 2005).

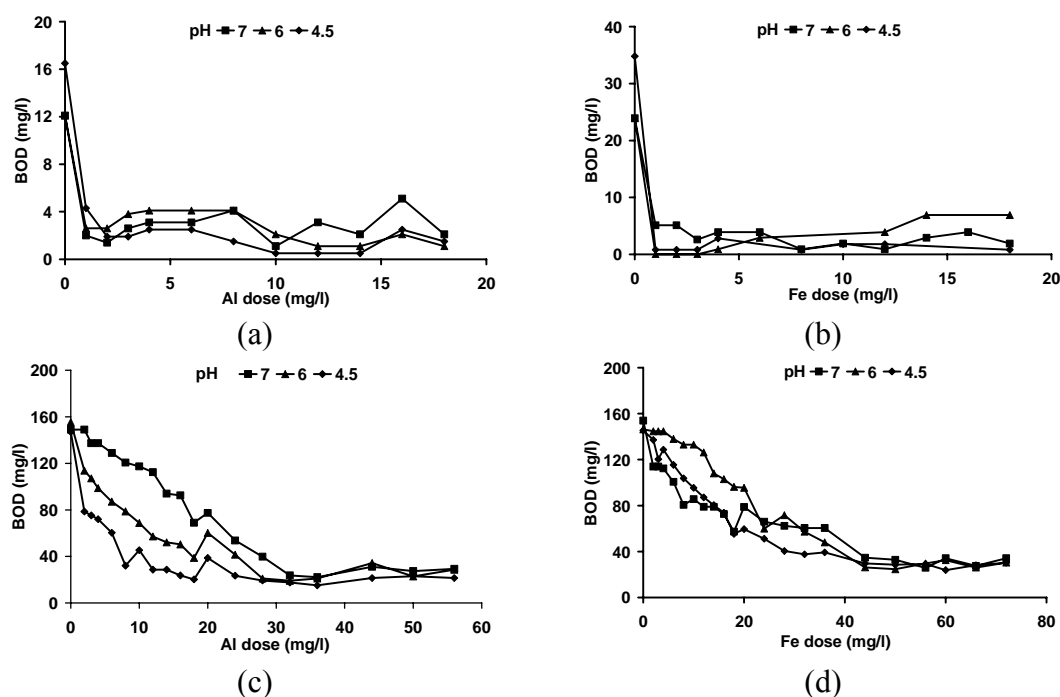

Figure 4.1: BOD residual after coagulation with alum and ferric for (a and b) mixed and (c and d) shower greywaters.

Comparison of the two coagulants revealed that the maximum level of removal was around 85% for both systems suggesting little difference in performance. Comparison of the required doses showed that more ferric was required by mass to achieve a set level of removal. Conversion to molar concentrations indicates the required minimum dose was 0.79 mM for ferric and 0.89 mM for alum indicating that in fact proportionally more alum was required per unit of treatment. Comparison with COD, DOC and UV_{254} revealed that the level of treatment was less dose and pH dependant in terms of these parameters. To illustrate, the most apparent case was in terms of UV_{254} where the level of removal remained around 74% in case of Alum. Information on the types of organics removed by the systems is provided by comparing the SUVA before and after treatment. For both coagulants, the SUVA decreased from 2.5-3.5

$\text{L.mg}^{-1}.\text{m}^{-1}$ in the raw water to $0.6 \text{ L.mg}^{-1}.\text{m}^{-1}$ in the treated effluent suggesting that mainly hydrophobic materials have been removed.

4.1.3 MIEX

Treatment of both greywater sources with MIEX[®] showed similar pattern to coagulation (Figure 4.2). For the mixed greywater, the treatment appeared once again to be independent of the contact time and dose, with BOD residual concentrations between 1 and 14 mg.L^{-1} over the range of conditions. Corresponding removal efficiencies varied between 80 and 99 % which reflects the low level of BOD in the influent. In contrast, the residual BOD of the shower greywater decreased as both the contact time and dose of MIEX[®] increased. To illustrate, at a 10 mL.L^{-1} MIEX[®] dose, BOD residuals were 60.2, 32.7, 27.6 and 17.6 mg.L^{-1} for respective contact times of 10, 30, 60 and 90 minutes. Whereas, for a 10-minute contact time, BOD residuals were 112.7, 85.7, 60.2 and 40.2 mg.L^{-1} for MIEX[®] doses of 2, 5, 10 and 20 mL.L^{-1} respectively. However, for doses higher than 10 mL.L^{-1} the residual BOD reached a plateau with removal efficiency of around 83% once the dose reached 20 mL.L^{-1} or above. Similar patterns were observed in terms of COD, DOC and UV_{254} except considerably less variation was observed between contact times in terms of UV_{254} . For example, in the case of the shower water with a MIEX[®] dose of 10 mL.L^{-1} the UV_{254} residuals were 0.158, 0.132, 0.134 abs at contact times of 10, 30 and 60 minutes respectively.

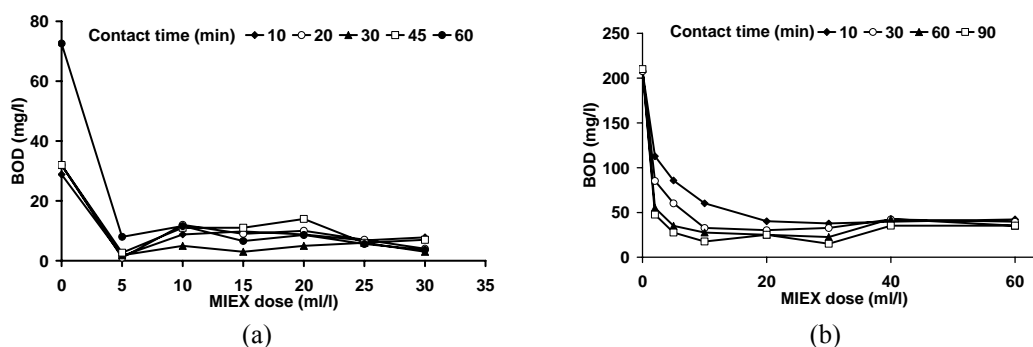

Figure 4.2: BOD residual after MIEX[®] treatment for (a) mixed and (b) shower greywaters.

A SUVA of less than 1 was found in the effluent suggesting that the residual organics are mostly hydrophilic in nature and MIEX[®] targets the same organics as the coagulation process. This agrees with the work of Fearing *et al* (2004) who studied

the use of MIEX[®] for natural organic matter removal and showed that only the very small, mostly hydrophilic materials remain after treatment.

4.1.4 Combined systems

A series of experiments were conducted on a combined system for which the greywater was first treated with the optimum dose of MIEX[®] and then coagulated with different doses of either ferric or alum. As both treatment systems were capable of achieving a sufficient treatment according to the water quality standards for the low strength greywater the combined treatment was only tested on the shower water. Residual BOD concentrations varied between 20 and 40 mg.L⁻¹ under all the conditions tested in terms of coagulant choice, dose and pH (Figure 4.3).

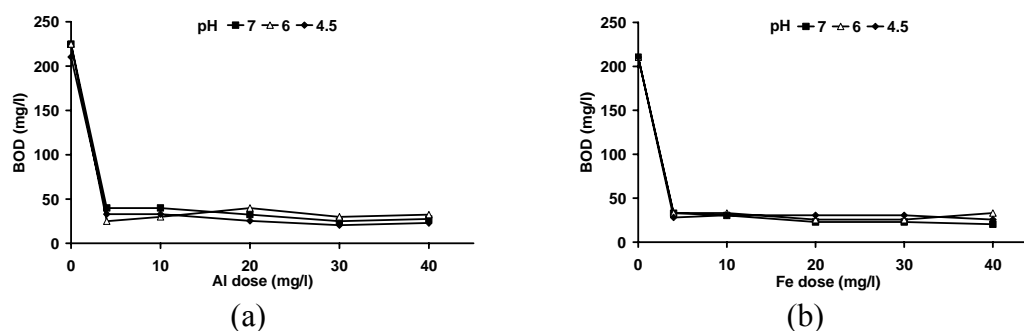

Figure 4.3: BOD residual after MIEX[®] + coagulation with (a) alum and (b) ferric for shower greywater.

Comparison with the previous tests reveals that the combined system was not able to reduce the BOD concentration below the level previously obtained. However it was found that this treatment was achieved independently of the coagulant dose or pH. Similar trends to the one presented for BOD were found for COD, DOC and UV₂₅₄. And removals of 64% COD, 53% DOC and 70% UV₂₅₄ were observed. Similarly, Singer and Bilyk (2002) reported removals between 53 and 96 % for UV₂₅₄ and between 46 and 87 % for TOC for the treatment of natural waters with MIEX[®] in combination with alum. The lower removals were observed for the raw waters with the lower SUVA. To illustrate, UV₂₅₄ removals of 53 and 94 % were recorded for waters with a SUVA of 1.4 and 4.5 L.mg⁻¹.m⁻¹ respectively. This confirms once more the preference of treatment of MIEX and coagulation for hydrophobic and high MW materials.

4.1.5 Comparison of the systems

With organic removals between 68 and 100%, both systems, coagulation and ion exchange, proved to be efficient at treating the mixed greywater to the most stringent standards for reuse with the lowest doses and contact times tested. However, the organic strength of the raw mixed greywater was a very low and it is consequently not surprising to see such treatment achieved. In the case of the shower water, optimum conditions were determined from the previous trials. The optimum dose of MIEX[®] was shown to be 10 mL.L⁻¹ at a contact time of 30 minutes (Table 4.2) to achieve a DOC removal of 54%. Similar dose and contact time were used for NOM removal in drinking water for a final DOC removal of 60% (Fearing *et al.*, 2004). The optimum conditions for coagulation were always observed at pH 4.5 and a dose of 24 mg.L⁻¹ (0.89 mM) alum and 44 mg.L⁻¹ (0.79 mM) ferric when used alone and a reduced dose of only 5 mg.L⁻¹ for both coagulants when used in combination with MIEX[®]. With these optimum doses of both ferric and alum, a general removal of 64% in terms of COD was then realised. Comparable studies presented similar results. Lin *et al.* showed that 25 mg.L⁻¹ of alum was needed to achieve a COD removal of 60% in a greywater treated by electro-coagulation. And a dose of only 5 mg.L⁻¹ alum was needed to achieve a 36% removal in a laundry wastewater with an initial COD of 280 mg.L⁻¹ (Sostar-Turk *et al.*, 2005). Effluent characteristics were similar for all five systems tested with a slight improvement in COD and DOC removal observed for the combined MIEX[®] and coagulant systems (Table 4.2). Residual turbidity was measured as 8.1, 4.2 and 5.2 for MIEX[®], alum and ferric respectively. In comparison the levels decreased to 3.3 and 3 NTU for the combined systems with ferric and alum respectively. This is once again similar to results found in the literature. El Samrani *et al.* (2004) reported a reduction of the turbidity from 40 to 5 NTU in sewage treated with a dose of 43 mg.L⁻¹ (0.77mM) of ferric. In the optimum conditions, the removal of the total coliforms was excellent at 3 log (99.8%) with MIEX[®] corresponding to a residual of 59.4 cfu.100mL⁻¹. In comparison all the other systems recorded a non detectable level in the effluent.

The combined system and coagulation achieved very similar performance. However, if considering a price of £0.06/kg (EA West, UK) of coagulant, at optimum doses the cost of coagulant would be £0.0026 and £0.0011 per litre of treated greywater with ferric and alum respectively. Because less coagulant is needed in the combined

system, the cost would be reduced to £0.0003 per litre of treated greywater. Hence, for the combined system to be more economically sustainable the cost of MIEX should be below £0.0023 and £0.0011 per litre of greywater treated when combined with ferric and alum respectively.

Table 4.2: Characteristics of the shower greywater effluent after treatment at optimum parameters.

	Raw	MIEX [®] 10 mL.L ⁻¹ , 30 mins	Alum 24 mg.L ⁻¹ , pH 4.5	Ferric 44 mg.L ⁻¹ , pH 4.5	MIEX [®] + Al 5 mg.L ⁻¹ , pH 4.5	MIEX [®] + Fe 5 mg.L ⁻¹ , pH 4.5
Optimum						
Turbidity (NTU)	46.60	8.14	4.28	5.20	3.01	3.30
COD (mg.L ⁻¹)	791	272	287	288	247	254
BOD (mg.L ⁻¹)	205.3	32.7	23.4	29.6	27.0	28.6
DOC (mg.L ⁻¹)	171.4	78.2	93.4	87.4	78.8	80.7
TN (mg.L ⁻¹)	18	15.3	15.7	17.9	15.3	17.4
NH ₄ ⁺ (mg.L ⁻¹)	1.2	1.1	1.2	1.2	1.2	1.2
NO ₃ ⁻ (mg.L ⁻¹)	6.7	4.7	5.7	6.1	4.4	4.8
PO ₄ ³⁻ (mg.L ⁻¹)	1.66	0.91	0.09	0.06	0.11	0.13
Total coliforms (cfu/100mL)	56500	59.4	<1	<1	<1	<1
<i>E.coli</i> (cfu/100mL)	6490	8.4	<1	1	<1	<1
Faecal <i>Enterococci</i> (cfu/100mL)	2790	<1	<1	<1	<1	<1

4.1.6 Discussion

Comparison with water recycling standards required for urban reuse indicates that coagulation and MIEX[®] are not always able to meet the required levels of treatment for all the situations. In the case of the shower water the treatment systems failed to comply with both the turbidity and organic concentration requirements. Comparison of the influent water strengths indicates that the maximum strength of the mixed systems was 72 mg.L⁻¹ BOD and the minimum of the shower water was 110 mg.L⁻¹. Consequently a threshold strength value appears to exist between these two limits

beyond which coagulant is unlikely to be able to meet effluent standards. In fact the systems appear unable to remove sufficient organics even at high doses of coagulant or MIEX[®] indicating that it is likely to be a recalcitrant proportion of the greywater to chemical solutions.

MIEX[®] is an ion exchange process specifically designed to remove NOM from potable water and is believed to be effective at removing mid and lower MW compounds. The results in the current study support this suggestion as the greatest removal was achieved with MIEX[®] alone (54%). In comparison in potable water treatment DOC removals with MIEX[®] alone are commonly 10-20 % lower than with coagulants although in combined systems the overall removal is slightly better than either MIEX[®] or coagulation alone (Fearing *et al.*, 2004).

The main coagulation mechanisms at the optimum pH are charge neutralisation for colloidal material and charge complexation for soluble material (Sharp *et al.*, 2006). In both cases the process is driven by charge interactions such that preferentially removal of charged materials is likely to occur. Consequently low charge or neutral materials are likely to be poorly removed although some removal is possible due to adsorption mechanisms on to the pre-formed flocs. This is supported by the fact that the zeta potential was always within the range previously reported for charge dominated processes (Sharp *et al.*, 2006). Examination of standard speciation diagrams suggested that at high doses applied sweep flocculation from the precipitated hydroxide should be the main removal mechanisms. The complexation reaction between organics and the metal coagulants are known to be fast. It is then likely that the complex precipitates rather than the straight hydroxide. Typical dose requirements for organic dominated systems are around 1:1 on a mass DOC per mass coagulant basis (Jarvis *et al.*, 2005). In the current study on the shower water optimum doses were observed at ratios of 7 for alum and 3.9 for ferric. The much lower levels required here relate to the nature of the feed water and its relatively low charge density. Conversion of the data to a mass ratio based just on the hydrophobic content of the grey water converts the dose ratio to around 1.2:1 which is around the level reported for coagulation of hydrophobic rich waters and indicates the differences between the dose ratios used for NOM removal and grey water are based on their respective hydrophilic contents.

Comparison to coagulation in other types of water showed that low removals were achieved in greywater. Indeed, coagulation of NOM in potable water treatment is

typically around 70-80 % DOC (Fearing *et al*, 2004) compared to 40-50% for greywater. The difference can be attributed to the make up of the organic molecules in both cases. NOM is mainly anionic hydrophobic humic and fulvic acids which are easily removed by coagulants. The residual are generally the smaller, hydrophilic neutrals that are difficult to remove by most treatment methods. Typical MW sizes for NOM are between 2000 and 5000 Da for the hydrophobics and <2000 Da for the hydrophilics based on UV absorption (Fearing *et al*, 2004). Greywater in contrast is mainly made up of <3000 Da material (Jefferson *et al.*, 2004) and appears to be mainly hydrophilic in nature (Table 4.1). Analysis of the SUVA supports this suggestion as the value decreases after coagulation suggesting the residual material is more hydrophilic in nature. Boyer and Singer (2005) also showed that both coagulation and MIEX[®] accomplished a better removal of UV₂₅₄ and DOC for raw waters with higher SUVA (> 3 L.mg⁻¹.m⁻¹) that is to say waters which contain mainly hydrophobic and high MW materials.

4.2 Adsorption

4.2.1 Background

This section presents a study of the efficacy of adsorption for the treatment of greywater for reuse. Adsorption has been widely used to remove organic matter from both wastewater and drinking water (Aksu, 2005). Typical pollutants removed by adsorption include pesticides, herbicides, detergents, polycyclic aromatic hydrocarbons, trihalomethanes and traces of heavy metals (Dabrowski, 2001). The process operates by removing specific components based on their size, charge, hydrophobicity and polarity. Depending on these parameters, each adsorbent has its own selectivity. The choice of the adsorbent is then important as it depends on the nature of the molecules to be removed. To illustrate, activated carbons have a surface essentially non-polar, hydrophobic and organophilic in opposition to activated alumina which are more polar and hydrophilic. However, both adsorbents are highly porous solids with complex networks of pores which give a large number of adsorption sites, essential for a good efficacy (Crittenden and Thomas, 1998). Because greywater is a complex mixture of different components, it was then decided to test a range of adsorbents: carbon adsorbents with two powdered activated carbons

of high and medium activity, mineral adsorbents with activated alumina and ferric hydroxide and a catalyst with titanium dioxide (Table 4.3).

Table 4.3: Adsorbent properties.

Adsorbent	Particle size (μm)	Surface area ($\text{m}^2\cdot\text{g}^{-1}$)
Activated Carbons	25	≤ 2500
Activated Alumina	3-5	300
Ferric Hydroxide	320-2000	18-292
Titanium Dioxide	<10	>250

Adsorption isotherms have been used to describe the efficiency of an adsorbent. The most commonly used are the Langmuir isotherm (Equation 4.1) and the Freundlich isotherm (Equation 4.3). However, a modified form of Freundlich isotherm (Equation 4.5) has also been used (Koopal, 1981; Hlady *et al.*, 1982; Summers and Roberts, 1988a and b).

$$\text{Langmuir isotherm: } q = \frac{bq_m C_e}{1 + bC_e} \quad \text{Equation 4.1}$$

$$\frac{1}{q} = \frac{1}{q_m} + \frac{1}{bq_m C_e} \quad \text{Equation 4.2}$$

Where, q ($\text{mg}\cdot\text{g}^{-1}$) represents the amount of material adsorbed per unit weight of adsorbent, C_e the concentration of material remaining in the solution ($\text{mg}\cdot\text{L}^{-1}$) at the equilibrium and b and q_m are constants. These constants can be determined by transforming Equation 4.1 into Equation 4.2 and plotting $\frac{1}{q}$ vs. $\frac{1}{C_e}$. The slope of the straight line will then be $\frac{1}{bq_m}$ and the intercept will be $\frac{1}{q_m}$.

$$\text{Freundlich isotherm: } q = K_f C_e^{1/n} \quad \text{Equation 4.3}$$

$$\log q = \log K_f + \frac{1}{n} \log C_e \quad \text{Equation 4.4}$$

Where, q and C_e are as described before and K_f and n are the Freundlich parameters. The Freundlich isotherm can be linearised (Equation 4) to determine the parameters by plotting $\log C_e$ against $\log q$ where $\log K_f$ will be the intercept and $\frac{1}{n}$ the gradient.

$$\text{Normalised Freundlich isotherm: } q = K_f \left(\frac{C_e}{D_0} \right)^{1/n} \quad \text{Equation 4.5}$$

In this case, the concentration at the equilibrium is normalised by the dose of adsorbent D_0 used.

4.2.2 Water sources

Similarly to the investigation of coagulation, the efficiency of adsorption was assessed on the treatment of different sources of greywater. In this case, three sources were used: the mixed source from the mixed greywater collected from the bathrooms of the Fedden house hall of residence at Cranfield University and two shower waters. The characteristics of the three greywaters are reported in Table 4.4.

Table 4.4: Greywaters Characteristics.

	Mixed (low strength)	Shower 1 (medium strength)	Shower 2 (high strength)
BOD (mg.l ⁻¹)	36±17	100±23	186±37
COD (mg.l ⁻¹)	149±63	292±68	498±98
COD/BOD	4.1	2.9	2.7
Turbidity (NTU)	33±16	21±6	44±9
TN (mg.l ⁻¹)	7.9±2.5	13.5±3.3	14.4±3.1
PO ₄ ³⁻ (mg.l ⁻¹)	0.6±0.2	0.3±0.1	1.3±0.1
NH ₄ ⁺ (mg.l ⁻¹)	0.9±0.8	0.4±0.4	1.0±0.3
NO ₃ ⁻ (mg.l ⁻¹)	3.4±1.6	7.5±2.5	6.3±1.2
pH	7.0±0.3	7.2±0.1	7.5±0.2

The three sources were chosen for their different organic contents. Hence, the treatment capacity of each adsorbent was studied on a complete range of greywater strength from low for the mixed source to medium and high strength for the shower waters 1 and 2 respectively. To illustrate, the BOD and COD of the three sources were 36 and 149 mg.L⁻¹ for the mixed source, 100 and 292 mg.L⁻¹ for the shower water 1 and 186 and 498 mg.L⁻¹ for the shower water 2. The COD to BOD ratios for the three greywaters were 4.1, 2.7 and 2.9 (Table 4.4) for the low, medium and high strength respectively. As observed before in the investigation of coagulation these values were fairly high in comparison to typical values reported for municipal

wastewater and suggest a limited biodegradability of the sources. This is supported by the values obtained for the COD:N:P ratio 1:0.05:0.004, 1:0.05:0.001 and 1:0.03:0.003 for low, medium and high strength sources respectively. Indeed, comparison with the same ratio for sewage, 1:0.09:0.02 (Metcalf and Eddy, 2003), confirms greywater's low nutrient content and consequently biodegradability.

4.2.3 Results and discussion

4.2.3.1 BOD removal

A first investigation of the treatment of the three water sources was carried out by monitoring the BOD residual in the effluent after treatment of the samples over a range of concentrations of each adsorbent. Similar trends for the BOD residual were observed for each adsorbent against the high and medium strength greywaters (Figure 4.3).

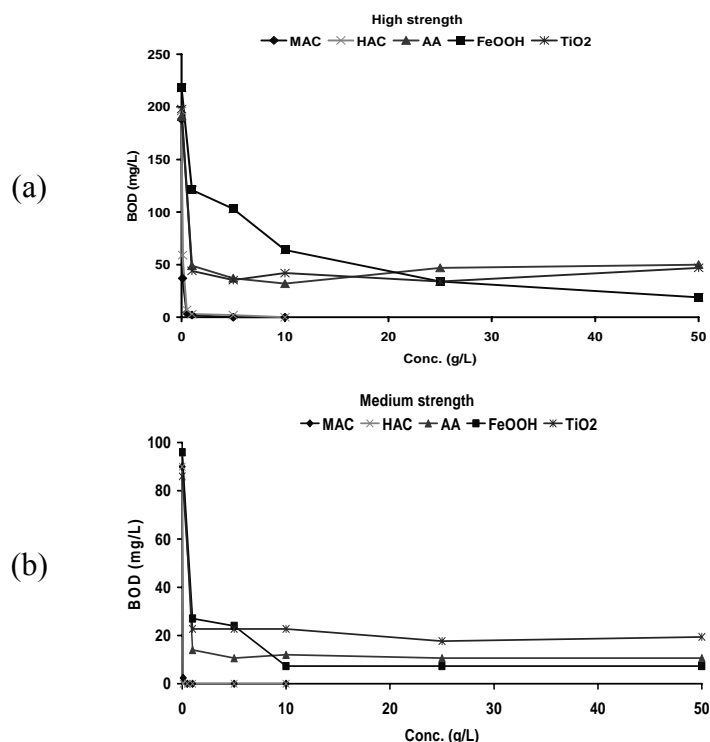

Figure 4.4: BOD residual after adsorption in high (a) and medium (b) strength greywaters.

Both medium activity (MAC) and high activity (HAC) activated carbons achieved almost complete BOD removals from the lowest doses tested. In the high strength greywater, BOD residuals of 4 and 7 were recorded for a concentration of 0.5 g.L^{-1} of

MAC and HAC respectively. BOD removal with activated alumina (AA) and titanium dioxide (TiO_2) were almost independent of the dose used. To illustrate, BOD residuals in the medium strength greywater were 14, 11, 12, 11 and 11 mg.L^{-1} for respectively 1, 5, 10, 25 and 50 g.L^{-1} of activated alumina. Finally, for ferric hydroxide (FeOOH), the BOD removal generally increased with the dose in the high strength greywater but stabilised for doses over 10 g.L^{-1} in the medium strength source. The BOD residuals monitored in the high strength greywater were 121, 103, 64, 34 and 19 mg.L^{-1} for ferric hydroxide concentrations of 1, 5, 10, 25 and 50 g.L^{-1} respectively.

In the low strength greywater, the BOD residuals for all the adsorbents were low, with the values between 0 and 9 mg.L^{-1} . They consequently all met the most stringent BOD standard for reuse of 10 mg.L^{-1} in the low strength greywater (Figure 4.5). Moreover, they all met this standard from the lowest dose tested, 0.1 g.L^{-1} for the activated carbons and 1.0 g.L^{-1} for the three others. Both activated carbons met this standard in the three sources with doses over 0.1 g.L^{-1} . Ferric hydroxide met the most stringent BOD standard for reuse in the low and medium strength sources and achieved sufficient treatment in the high strength shower for countries such as Japan and Australia which have a standard for BOD of 20 mg.L^{-1} . However, the doses needed for such treatments were elevated, generally higher than 5 g.L^{-1} .

Ultimately, in the medium strength source, the minimum BOD residual of 11 and 18 mg.L^{-1} observed for activated alumina and titanium dioxide respectively were just enough to meet the 20 mg.L^{-1} standard. Nevertheless, with minimum residual of just over 30 mgBOD.L^{-1} in high strength greywater, they never met any standards with the doses tested.

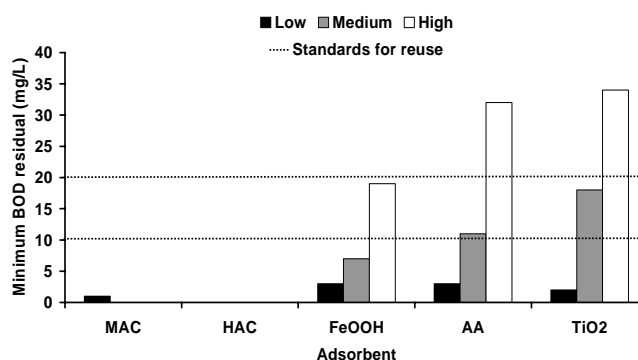

Figure 4.5: Minimum BOD residual observed within the three greywaters after treatment with each adsorbent.

The treatment achieved by adsorption is comparable to what can be found in the literature for other technologies (Table 4.5). Indeed, BOD removal of over 90 % were recorded for technologies such as MBR and reedbeds for the treatment of medium to high strength greywaters equivalent to the treatment obtained by the activated carbons and the ferric hydroxide.

Table 4.5: BOD removal from greywater by different technologies.

	Influent (mg.L ⁻¹)	Effluent (mg.L ⁻¹)	Removal (%)
Activated carbons	28	1	96
	192	0	100
Ferric hydroxide	34	3	91
	218	19	91
Activated alumina	28	3	89
	191	32	83
Titanium dioxide	18	2	89
	198	34	83
Electrocoagulation ¹	23	9	61
MBR ²	99-212	<5	>94
Reedbed ³	167	10	94
Sand filter ⁴	52-66	<10	>80

¹ Lin *et al.* (2005); ² Liu *et al.* (2005); ³ Dallas *et al.* (2004); ⁴ Gardner *et al.* (2000).

4.2.3.2 Optimum doses

From the BOD residual results seen before, an optimum dose of each adsorbent has been determined for the three sources and further experiments were carried out. General COD removal for the three sources with all the adsorbents were between 50 and 80 % (Table 4.6) with the better removals observed for the two activated carbons and ferric hydroxide. Similar treatment for greywater was observed by Liu *et al.* (2005) (69 %) and Lin *et al.* (2005) (60 %) achieved by a membrane bioreactor and coagulation with an aluminium dose of 25 mg.L⁻¹ respectively. Bansode *et al.* (2004) also reported a COD removal of 75 % for the treatment of municipal wastewater by GAC. However, slightly different trends were observed with the DOC results. Indeed, similar DOC residuals were recorded with the activated carbons, activated alumina and ferric hydroxide in the three waters as if there was a recalcitrant fraction that could not be removed. However, DOC removal of between 69 and 74 % were achieved by the activated carbons and ferric hydroxide in the high strength greywater. Comparison with the literature shows that these results were better than the 65 % removal reported by Ahn *et al.* (1998) for greywater treatment by a membrane or the

63 % removal reported by Lee *et al.* (2005) for the treatment of secondary effluent by powdered activated carbon. Moreover, as observed for BOD and COD, titanium dioxide showed poor ability to remove DOC especially at higher strength. Comparison with the literature shows for all the adsorbents tested in the three greywaters, the turbidity residual observed were comparable and around 1 NTU.

Table 4.6: Organic residuals after treatment at the optimum doses.

Source		Raw	AA	FeOOH	HAC	MAC	TiO ₂
Low	Dose (g.L ⁻¹)		1.0	1.0	0.1	0.1	1.0
	COD (mg.L ⁻¹)	129	44	50	40	32	68
	DOC (mg.L ⁻¹)	21	13	15	17	17	10
Medium	Dose (g.L ⁻¹)		5.0	10.0	0.1	0.1	5.0
	COD (mg.L ⁻¹)	315	122	90	104	90	154
	DOC (mg.L ⁻¹)	43	23	12	24	23	30
High	Dose (g.L ⁻¹)		10.0	10.0	0.5	0.5	5.0
	COD (mg.L ⁻¹)	491	158	166	132	91	196
	DOC (mg.L ⁻¹)	62	25	19	16	16	46

The microbiological content of the medium and high strength showers were similar, but generally lower than in the low strength source. For instance, the total coliforms were in the range of 10⁵-10⁶ cfu/100mL in the low strength source and around 10⁴ cfu/100mL in the showers (Table 4.7). These correspond to values found in the literature for bathroom waters, which is to say between 10² and 10⁸ cfu/100mL (Eriksson *et al.*, 2002).

Table 4.7: Microbiological contents.

	Strength	Raw	AA	FeOOH	HAC	MAC	TiO ₂
Total Coliforms (cfu/100ml)	low	620000	17900	25200	8500	9400	2200
	medium & high	20000	800	1400	200	100	56
<i>E.Coli</i> (cfu/100ml)	low	500	53	77	40	47	3
	medium & high	260	ND	ND	ND	ND	ND

ND: not detectable.

A general removal of between 1 and 2.5 log was observed for total coliforms in the three sources and for *E. Coli* in the mixed source. However, a complete removal of *E. Coli* was observed in the two showers, due to the fact that they had a lower initial concentration. To compare, Gardner *et al.* (2000) reported a removal by sand filter of 0.8 log total coliforms with a residual in the effluent between 1950 and 4920 cfu/100mL. A complete removal of *E. Coli* from an initial concentration of 5100

cfu/100mL was also reported by Lin *et al.* (2005) in the treatment of greywater by electrocoagulation. Finally, a reedbed achieved a removal of over 4 log faecal coliforms to obtain a treated greywater with a concentration of 6300 cfu/100mL (Dallas *et al.*, 2004). To conclude, adsorption does not appear to be a particularly good technology to remove bacteria; however, in the case of a scale-up it could be coupled with a disinfection process such as UV or chlorination as it has often been seen for simple physical systems.

Finally, ferric hydroxide and the two activated carbons showed the best performance and so the best ability to treat greywater for reuse. Indeed, they were able to treat both low and medium strength greywaters to the strictest standards of 2 NTU for turbidity and 10 mg.L⁻¹ for BOD. Nevertheless, only the activated carbons repeated similar performance for the high strength greywater. Finally, none of the adsorbents were able to achieve the removal expected for greywater reuse in terms of total coliforms. The adsorbent with the highest specific surface area should provide a better treatment due to more adsorption sites available. However, it is also dependent on the pore structure of the adsorbent and the size of the pollutants to be adsorbed (Cooney, 1999). This was verified as the best performance was observed with the use of the activated carbons which are from all the adsorbents tested the ones with the highest specific surface area, $\leq 2500 \text{ m}^2.\text{g}^{-1}$ (Table 4.3). To illustrate, the BOD removal normalised to area was 0.03, 0.05, 0.06 and 0.35 mg.m⁻² for ferric hydroxide, activated alumina, titanium dioxide and activated carbons respectively.

4.2.3.3 Adsorption isotherms

With regards to the different isotherm equations, better correlations, as based on DOC concentrations, were found for the standard and normalised Freundlich isotherms than for the Langmuir isotherm (Table 4.8). However, the best fit was obtained for the normalised Freundlich isotherm with coefficients of determination r^2 above 0.86 and generally around 0.97. The normalised Freundlich isotherm was first applied for the adsorption of polydisperse systems of polymers (Koopal, 1981; Hlady *et al.*, 1982) and then successfully tested for adsorption of humic substances (Summers and Roberts, 1988a and b). It was found for such products that for low adsorbent dose, the high MW materials are preferentially adsorbed on the surface.

Table 4.8: Adsorption isotherms correlations.

Strength	Langmuir			Freundlich			Normalised Freundlich		
	Low	Medium	High	Low	Medium	High	Low	Medium	High
MAC	0.70	0.70	0.67	0.96	0.90	0.95	0.97	0.97	0.98
HAC	0.69	0.70	0.53	0.87	0.87	0.96	0.99	0.97	0.98
FeOOH	0.64	0.64	0.15	0.89	0.86	0.72	0.87	0.98	0.86
TiO ₂	0.77	0.77	0.65	0.81	0.92	0.87	0.98	0.98	0.98

Alternatively, for higher adsorbent dose, both low and high MW materials are adsorbed resulting in a smaller amount adsorbed per unit area. In this case, the appropriate parameter to study is the ratio of the amount of unadsorbed materials to adsorbent dose rather than the concentration in the solution. When applied to a same system adsorbent/solute with different initial concentrations of solute, the result is a unique isotherm. Although a good fit of the experimental data of this study was found with the normalised Freundlich isotherm, the unique isotherm was never observed with the three greywater strengths and the adsorbents tested (Figure 4.6).

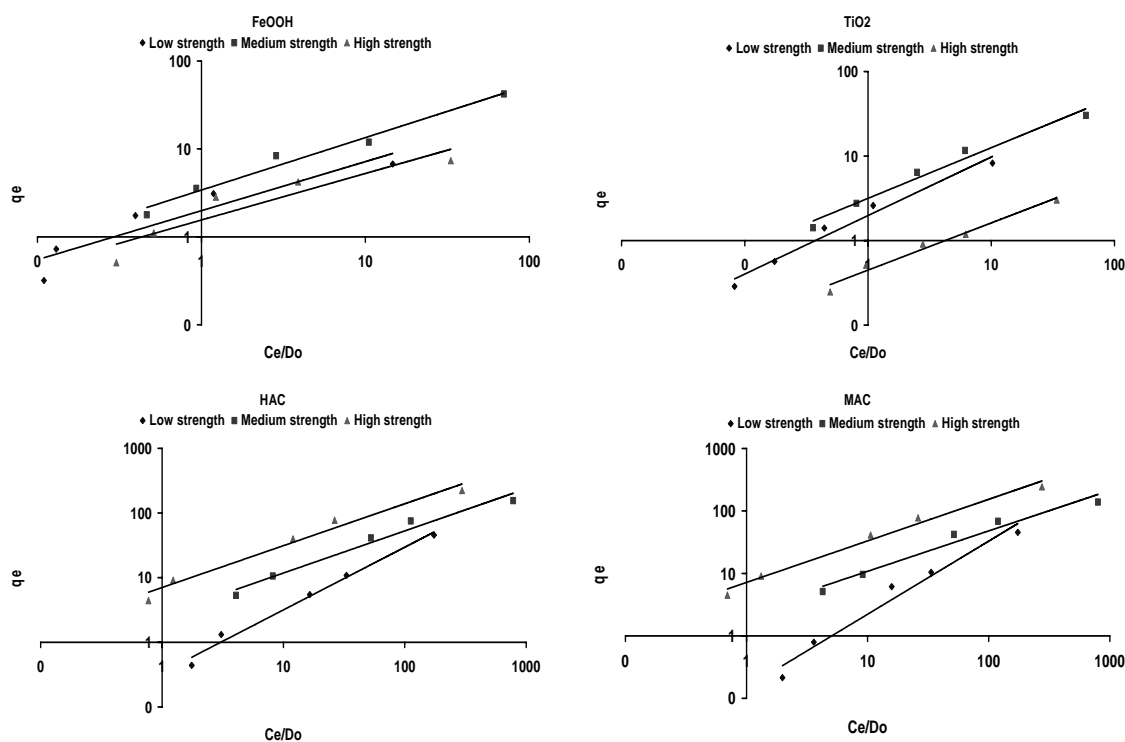

Figure 4.6: Normalised Freundlich isotherms for the different adsorbents in the low, medium and high strength greywaters.

This can be explained by the composition of the greywaters in opposition to the polymer or humic substances. Greywater is mainly composed of hydrophilic and low MW materials (<3 kDa) (Jefferson *et al.*, 2004) in opposition to humic substances

which are usually more hydrophobic and high MW (Summers and Roberts, 1988a). Moreover, in the previous studies for humic substances and polymers, synthetic solutions were used so that a range of concentrations of the same solute was investigated. In this study, we used three real greywaters of which the compositions were different because of the use of different products.

When analysing the isotherms obtained with the different systems investigated in this study we can observe two trends. Indeed, both activated carbons gave really similar results in comparison to the two other adsorbents, the ferric hydroxide and the titanium dioxide. The Freundlich parameters K'_f and $1/n$, the capacity factor and intensity parameter respectively (Aksu, 2005) were then obtained from the isotherms for each pair adsorbent/water source (Table 4.9).

Table 4.9: Parameters from the normalised Freundlich isotherms obtained for each adsorbent in the 3 greywaters.

	Low strength		Medium strength		High strength	
	K'_f	$1/n$	K'_f	$1/n$	K'_f	$1/n$
MAC	0.15	1.17	2.43	0.65	7.16	0.67
HAC	0.34	0.97	2.62	0.65	7.02	0.65
FeOOH	1.99	0.56	3.41	0.60	1.56	0.53
TiO ₂	1.98	0.69	3.16	0.60	0.45	0.56

For the two activated carbons the capacity factor K'_f increased with the strength. To illustrate, the values for K'_f were 0.34, 2.62 and 7.02 for the high activity carbon and 0.15, 2.43 and 7.16 for the medium activity carbon in the low, medium and high strength sources respectively. This shows that for the activated carbons a better adsorption capacity was observed in the higher strength sources. As it was noted before, the DOC residuals were similar in the three sources after treatment by adsorption (Table 4.6) consequently a much higher removal was observed in the higher strength sources. This explains the better adsorption capacity observed in the high strength greywater. In opposition, for the ferric hydroxide and the titanium dioxide, K'_f was found higher in the medium strength source with values of 3.41 and 3.16 respectively. And the lowest values with 1.56 for FeOOH and 0.45 for TiO₂ were recorded in the high strength greywater. This validates the results obtained for the treatment performance of the two adsorbents. Both adsorbents showed a better ability to treat lower strength greywaters. The lowest capacity factor of 0.45 is found for the titanium dioxide which was the most limited to treat the high strength source. Similar

intensity parameter, $1/n$, were found with values between 0.53 and 0.69 for all the adsorbents in the three waters except for the two activated carbons in the low strength greywater with values of 0.97 and 1.17. These values were generally higher than what is reported in the literature for humic substances or natural organic matter (NOM). Summers and Roberts (1988a) reported for four humic and fulvic acids solutions intensity parameters around 0.3. Similarly, Karanfil *et al.* (1999) showed intensity parameter ranging from 0.179 to 0.547 for the treatment of NOMs with different granular activated carbons. And finally, Kilduff *et al.* (1996) reported intensity parameter between 0.118 and 0.245 for treatment of different size fractions of a humic acid with activated carbon. The higher intensity parameters observed in this study illustrate a more important influence of the adsorbent dose on the adsorption capacity.

4.3 Semiconductor photocatalysis

4.3.1 Background

The use of semiconductor photocatalysis for the treatment of water and wastewater has emerged in the past decade (Parsons, 2004). Research of semiconductors for water treatment has led to titanium dioxide (TiO_2) being the best option and is now the most commonly used for such applications (Parsons, 2004). The only limitation to titanium dioxide is that it does not absorb visible light but only ultraviolet (UV) light (typically $<380\text{ nm}$) (Parsons, 2004).

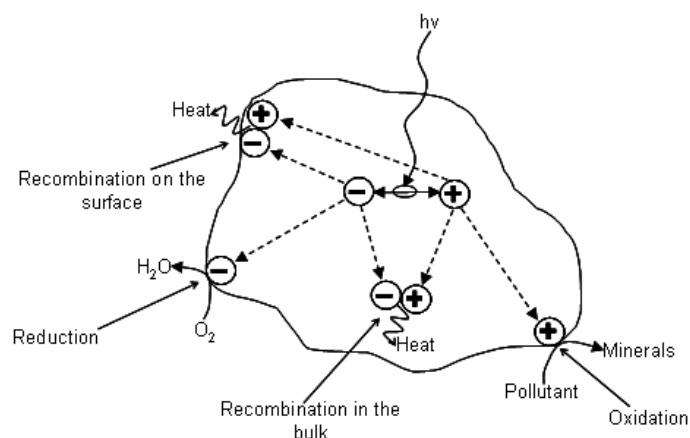

Figure 4.7: Semiconductor photocatalysis (adapted from Parsons (2004)).

Semiconductors are materials that have an electrical conductivity between the one of metals and insulators. Their electronic structure includes a band almost full of electrons called the valence band and the next empty one called the conduction band separated by a bandgap. The photocatalysis process (Figure 4.7) consists of illuminating the semiconductor, titanium dioxide, with UV light and the adsorption of photons of energy $h\nu$ higher than the bandgap energy generates electron-hole (e^-h^+) pairs. Then different reactions can occur. First, the e^- and the h^+ can recombine, either in the semiconductor or at its surface to produce heat. If recombination has not occurred and the e^- and/or the h^+ made their way to the surface of the titanium dioxide, reactions of oxidation or reduction will take place. Indeed, the electron will reduce oxygen (O_2) adsorbed on the surface into water (H_2O). Similarly, the holes will oxidise pollutants adsorbed on the surface into their mineral forms which usually are carbon dioxide (CO_2) and water (H_2O).

4.3.2 Membrane chemical reactor (MCR)

The membrane chemical reactor is a slurry tank reactor for semiconductor photocatalysis combined with a membrane for the separation of the slurry and this section presents its investigation in a batch operation for the treatment of greywater.

4.3.2.1 Performance

The MCR was tested for different TiO_2 concentration (5 and 10 $mg.L^{-1}$), air velocities (0.5 and 1.25 $m.s^{-1}$) in the recirculation loop and fluxes for the treatment of shower greywater. The performances observed for these tests are reported in Table 4.10.

Table 4.10: Performance of the MCR in batch operation.

U_{air} ($m.s^{-1}$)	TiO_2 ($mg.L^{-1}$)	Permeate flux ($L.m^{-2}.h^{-1}$)	BOD ($mg.L^{-1}$)		COD ($mg.L^{-1}$)		Turbidity (NTU)	
			In	Out	In	Out	In	Out
0.5	5	15	135	17	324	72	18.7	0.64
1.25	5		135	5	324	56	18.7	1.10
0.5	10		114	2	290	68	15.6	1.35
1.25	10		128	5	252	68	16.9	1.67
0.5	5	55	135	14	324	98	18.7	0.63
1.25	5		135	9	324	86	18.7	0.35
0.5	10		114	2	290	76	15.6	3.57
1.25	10		128	10	252	84	16.9	1.77

It has been shown earlier that titanium dioxide when used as an adsorbent achieved limited treatment of greywater especially at higher organic strength (Chapter 4.2). However, when used as a photocatalyst different performance was expected. Indeed, a previous study showed that TiO_2 used as a photocatalyst removed a further 20% of the organic fraction within greywater than when it was used as a simple adsorbent (Parsons *et al.*, 2000). Indeed, the MCR achieved a very good organic removal with COD removals generally between 67 and 87% and BOD removals between 87 and 98%. Moreover, the BOD residuals were mostly below 10 mg.L^{-1} corresponding to the most stringent standard worldwide for greywater recycling. Parsons *et al.* (2000) also reported excellent general performance of the system TiO_2/UV with removal of up to 90% of the organics (as DOC) and 6 log of the total coliforms for the treatment of a very high strength synthetic greywater with initial DOC concentration of up to 660 mg.L^{-1} . Similarly, Al-Bastaki (2003) reported COD removal between 60 and 80% in secondary effluent treated with TiO_2/UV photocatalysis. Interestingly, the MCR also achieved very good turbidity removal with residuals generally found below the most stringent standard for reuse of 2 NTU. This showed that, as expected, the membrane stopped the suspended solids as well as the TiO_2 particles from passing in the effluent. It should be noted that little difference in terms of performance between the different doses and air velocities tested were observed. From an economic point of view the MCR should then be operated with the lower dose and air velocities tested.

4.3.2.2 Membrane fouling

The major issue when using membrane technology is the fouling phenomena. The influence of parameters such as the TiO_2 dose, the use of the UV light and the air velocity in the recirculation loop on the fouling of the membrane during the treatment of greywater has been assessed by studying the permeability of the membrane (A more complete investigation of membrane fouling in the MCR is reported in Chapter 5.3 and Chapter 6.1). The presence of TiO_2 in the reactor had an influence on the permeability (Figure 4.8a). Indeed, the permeability decreased when a TiO_2 dose of 5 g.L^{-1} was added to the greywater, illustrated by a drop from 133 to $93 \text{ L.m}^{-2}.\text{h}^{-1}.\text{bar}^{-1}$ of the permeability. However, no further effect was observed on the permeability when the TiO_2 dose was increased up to 10 g.L^{-1} suggesting that the amount of TiO_2 had little effect on the fouling of the membrane. Moreover, no significant fouling

could be observed during these tests as the fouling rates were found to be below $0.8 \text{ mbar}\cdot\text{min}^{-1}$ for fluxes up to $55 \text{ L}\cdot\text{m}^{-2}\cdot\text{h}^{-1}$. Similar results were found during the investigation of the other parameters. Indeed, a test carried out with the UV lights off in one case and on in the other one with a TiO_2 dose of $5 \text{ g}\cdot\text{L}^{-1}$ (Figure 4.8b) showed that little difference could be observed between the two conditions but the permeability was slightly higher with $104 \text{ L}\cdot\text{m}^{-2}\cdot\text{h}^{-1}\cdot\text{bar}^{-1}$ with the UV lights on in comparison to $93 \text{ L}\cdot\text{m}^{-2}\cdot\text{h}^{-1}\cdot\text{bar}^{-1}$ when they were off. A very similar trend was found with a TiO_2 dose of $10 \text{ g}\cdot\text{L}^{-1}$ with permeability of 101 and $91 \text{ L}\cdot\text{m}^{-2}\cdot\text{h}^{-1}\cdot\text{bar}^{-1}$ with the lights on and off respectively. These results reveal a slight improvement of the filtration conditions when the greywater is being treated by the photocatalytic oxidation. However, even in these conditions the TiO_2 dose did not seem to influence the permeability. Similarly to what was observed earlier without the UV lights, very little difference could be observed between the two doses of 5 and $10 \text{ g}\cdot\text{L}^{-1}$ with permeability of 104 and $101 \text{ L}\cdot\text{m}^{-2}\cdot\text{h}^{-1}\cdot\text{bar}^{-1}$ respectively (Figure 4.8c). Finally, the system was assessed with difference air velocities in the membrane module (Figure 4.8d). Once again, little difference was found between the two air velocities but generally higher permeability was observed for higher air velocity no matter the TiO_2 dose and the UV lights condition. To illustrate, during the photocatalytic oxidation of shower water with a TiO_2 dose of $10 \text{ g}\cdot\text{L}^{-1}$ permeability of 113 and 101 were recorded for air velocities of 1.25 and $0.5 \text{ m}\cdot\text{s}^{-1}$ respectively.

4.4 Conclusion

The results obtained in this study suggests that chemical processes such as coagulation and MIEX[®] can achieve reasonable levels of organic removal; however, they are not capable of meeting the most stringent standards for reuse reported around the world. The observed limitation appears to be governed by the character of the raw greywater and suggest that such processes are never going to be suitable for very strict standards unless they are combined with another process that can achieve the remaining removal.

Similarly, the range of adsorbents tested in this study has shown a general ability to treat low to medium strength greywater to the physical and chemical standards for reuse. However, only the activated carbons proved a real efficiency for greywater recycling as they were able to treat to the standards all strengths of greywater.

Moreover, they achieved such treatment with lower dose ($0.1-0.5 \text{ g.L}^{-1}$) in opposition to the other adsorbents which for their best performance required doses at least ten times higher. The main limitation of the adsorption process seen in this study was that none of the adsorbents trialled were able to remove micro-biological pollution present within the different greywaters. This implies that a disinfection process would have to be added to the adsorption system in the case of full scale operation.

Finally, the membrane chemical reactor is the technology that showed the most complete ability to treat greywater for reuse. Indeed, the MCR achieved very good treatment of medium to high strength greywater with effluent generally below the 10 mg.L^{-1} for BOD, 2 NTU for turbidity as well as undetectable levels of coliforms due to the disinfection action of the UV lights. Moreover, no significant membrane fouling was observed when the MCR was operated in batch mode which is promising for an investigation on a continuous mode.

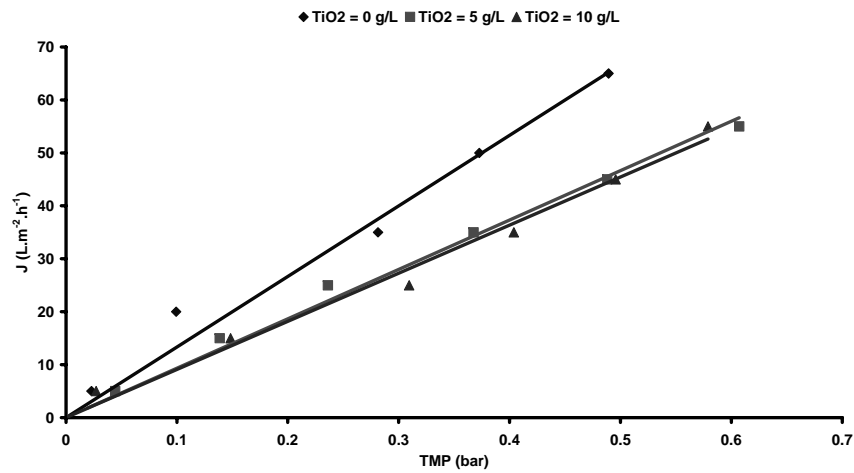

(a)

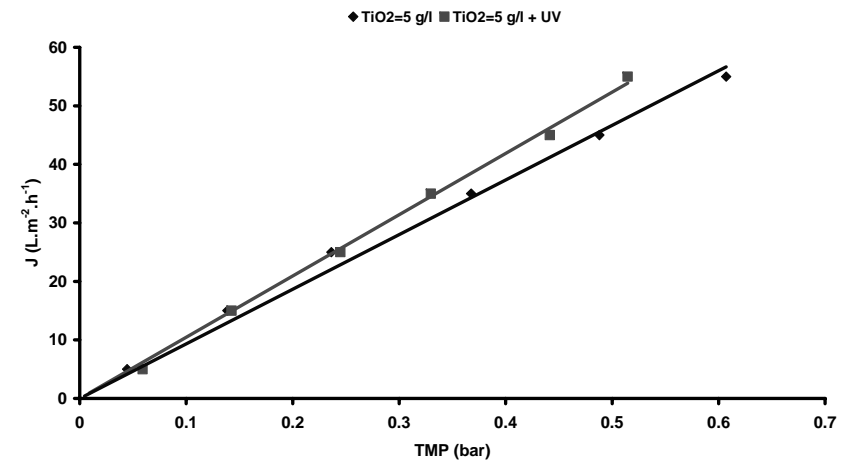

(b)

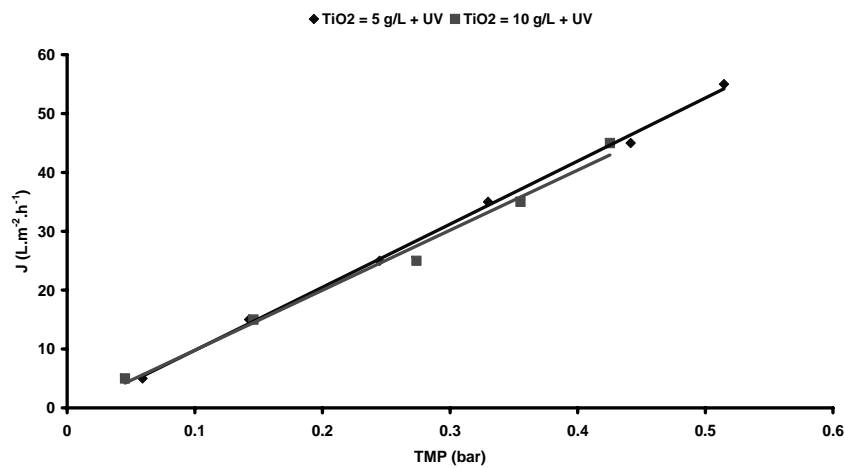

(c)

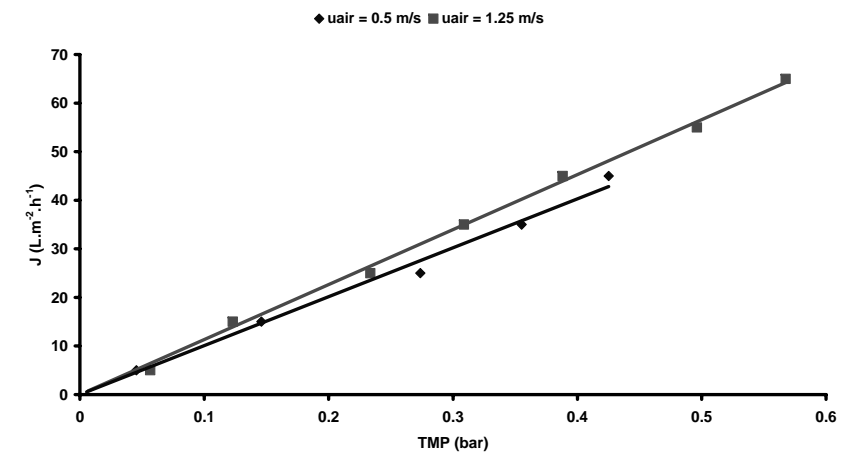

(d)

Figure 4.8: Influence of (a) TiO₂, (b) the UV illumination, (c) the TiO₂ dose and (d) the air velocity on the membrane permeability.

Chapter 5 Pilot study: MBR vs. MCR

5.1 Performance

5.1.1 Results

For the investigation of the two pilot plants, greywater from the bathroom of student flats was used (Table 5.1). This source is the same low strength mixed greywater used for the coagulation and adsorption trials in Chapter 4. Any differences observed for the water quality parameters of the source between the two investigations are due to the variability of greywater characteristics in time. To illustrate, in the current trials the BOD was 16 ± 7 mg.L⁻¹ compared to 39 ± 17 mg.L⁻¹ during the previous trial. As reported earlier (Chapter 4), the characterisation of the greywater collected revealed a very low organic content. Indeed, average concentration of 100 mg.L⁻¹ and 16 mg.L⁻¹ for COD and BOD respectively were measured. A comparison with the corresponding values available in the literature (Appendix I), BOD concentration generally ranging from 5 to 270 mg.L⁻¹, shows that this greywater is situated at the bottom end of the range in terms of organic strength.

Table 5.1: Effluents quality with low strength greywater.

	Feed	MBR1		MBR2		MCR	
		Residual	Removal (%)	Residual	Removal (%)	Residual	Removal (%)
COD*	100 ± 21	39 ± 7	61	44 ± 11	56	43 ± 14	57
BOD*	16 ± 7	1 ± 1	94	1 ± 1	94	3 ± 2	81
Turbidity [#]	11.8 ± 5.5	0.1 ± 0.1	99	0.2 ± 0.2	98	0.1 ± 0	99
DOC*	11 ± 11	7 ± 10	36	7 ± 10	36	4 ± 8	64
TN*	6.2 ± 4.4	4.8 ± 2.8	23	5.1 ± 3.2	18	4.0 ± 0.8	35
NH ₄ ⁺ *	0.7 ± 0.7	0.3 ± 0.2	57	0.2 ± 0.2	71	0.6 ± 0.4	14
NO ₃ ⁻ *	1.7 ± 0.8	4.1 ± 1.5	/	3.9 ± 1.5	/	2.5 ± 1.0	/
PO ₄ ³⁻ *	0.6 ± 0.3	1.0 ± 0.8	/	0.7 ± 0.5	/	0.4 ± 0.3	33
Total coliforms [~]	1 × 10 ⁶ ± 2 × 10 ⁶	-	-	-	-	-	-
E. Coli [~]	2 × 10 ³ ± 4 × 10 ³	-	-	-	-	-	-

*: in mg.L⁻¹; #: in NTU; ~: in counts.100mL⁻¹; /: no removal or increase.

After a study of the performance of the two systems with the low strength greywater, it was decided for the purpose of the investigation to increase the organic strength of

the greywater to levels seen in the literature by dosing a high strength synthetic greywater. A dosing system was then fitted in the collection system and a solution of shampoo diluted in tap water was dosed. This provided a significant increase of the organics concentration (Table 5.2) with average COD and BOD concentrations of 400 mg.L⁻¹ and 151 mg.L⁻¹ respectively.

Table 5.2: Effluents quality with high strength greywater.

	Feed	MBR1		MBR2		MCR	
		Residual	Removal (%)	Residual	Removal (%)	Residual	Removal (%)
COD*	400 ± 50	48 ± 23	88	51 ± 23	87	79 ± 18	80
BOD*	151 ± 23	1 ± 1	99	1 ± 2	99	9 ± 8	94
Turbidity [#]	29.8 ± 8.0	0.2 ± 0.1	99	0.2 ± 0.1	99	0.7 ± 1.1	98
DOC*	53 ± 8	20 ± 2	62	21 ± 2	60	31 ± 5	42
TN*	5.9 ± 1.5	3.0 ± 2.3	49	4.3 ± 7.3	27	3.9 ± 2.4	34
NH ₄ ⁺ *	0.1 ± 0.2	0.2 ± 0.4	/	0 ± 0	100	2.5 ± 3.5	/
NO ₃ ⁻ *	1.1 ± 0.9	1.8 ± 1.5	/	3.7 ± 6.7	/	0.7 ± 0	36
PO ₄ ³⁻ *	0.4 ± 0.4	1.1 ± 1.6	/	0.7 ± 1.2	/	0.1 ± 0.1	75
SS*	51 ± 27	2 ± 2	96	1 ± 1	98	2 ± 1	96
Total coliforms [~]	5 × 10 ⁷ ± 8 × 10 ⁷	4 ± 8	7.1 [□]	4 ± 8	7.1 [□]	0 ± 0	7.7 [□]
E. Coli [~]	4 × 10 ⁴ ± 10 ⁵	0 ± 0	4.6 [□]	0 ± 0	4.6 [□]	0 ± 0	4.6 [□]

*: in mg.L⁻¹; #: in NTU; ~: in counts.100mL⁻¹; /: no removal or increase; □: log removal.

Alternatively, the dosing of the high strength solution did not change the nutrient content of the greywater. For example, the total nitrogen concentration was 6.2 and 5.9 mg.L⁻¹ in the low and high strength sources respectively. Interestingly, the micro-organisms count increased from the low to high strength greywater. For instance, total coliforms counts increased from 10⁶ to 5 × 10⁷ cfu.100mL⁻¹. In terms of organic strength, the high strength greywater studied here is situated in-between the two shower waters used in the adsorbition investigation (Chapter 4.2). To illustrate, average BOD concentrations of 292 and 498 mg.L⁻¹ in the two shower sources and 400 mg.L⁻¹ in the strengthened mixed greywater were measured. This shows that all processes' performance were studied on similar range of organic strength.

The MBR was first tested for the treatment of the low strength greywater over a period of 3 months (Figure 5.1). The performance data for this period achieved by the two reactors are reported in Table 5.1. For the whole investigation, the hydraulic parameters were identical at any given time in the two reactors consequently the

treatment performance were very similar. Removal of about 60% COD, 94% BOD and 98% turbidity were monitored. These correspond to residual of 1 mg.L^{-1} for the BOD and 0.2 NTU for the turbidity. A slight reduction of the total nitrogen and the ammonium ions was observed along an increase of the nitrate ions concentration from 1.7 mg.L^{-1} in the raw greywater to 4 mg.L^{-1} in the effluent.

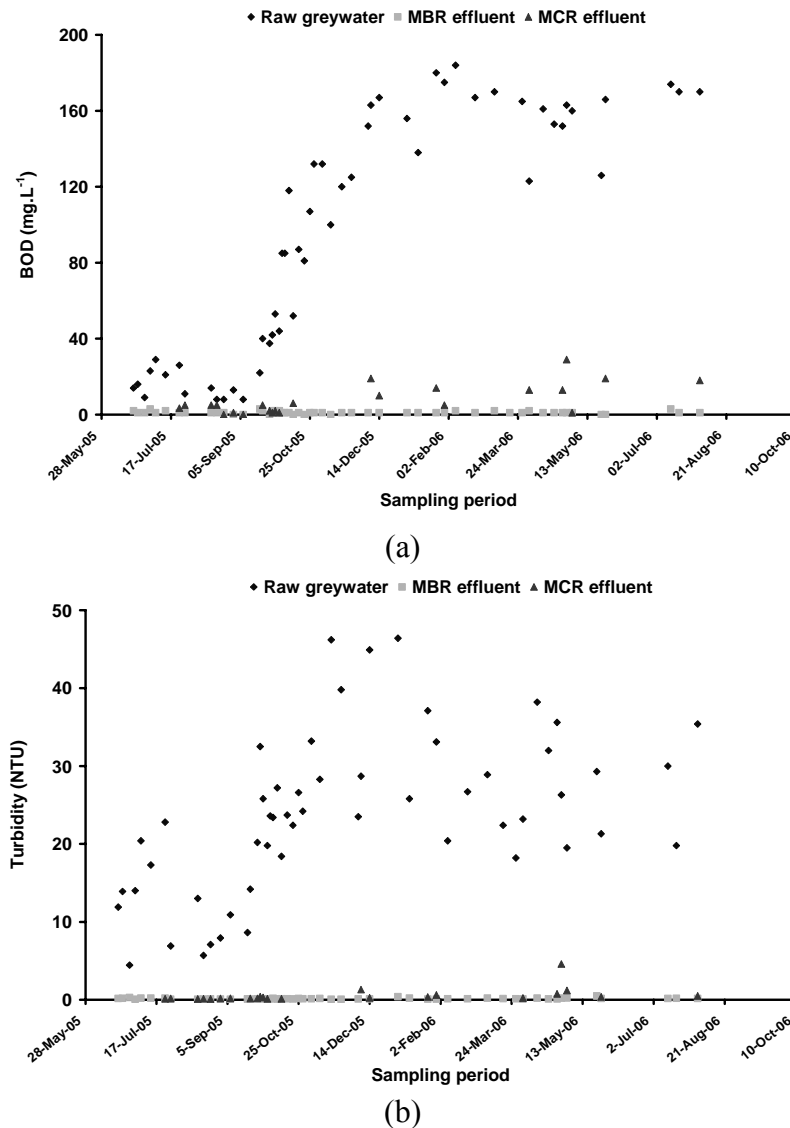

Figure 5.1: Raw greywater and effluents (a) BOD and (b) turbidity concentrations with time.

The high strength MBR trial was conducted over 10 months and revealed almost complete removal of BOD and turbidity with residual of 1 mg.L^{-1} and 0.2 NTU respectively (Table 5.2). These correspond to removals of over 99%. A removal of 96% was also observed for the suspended solids with residual of about 2 mg.L^{-1} . Interestingly, the $50 \pm 23 \text{ mg.L}^{-1}$ COD residual achieved with the high strength

greywater was very close the $41 \pm 11 \text{ mg.L}^{-1}$ observed earlier for the low strength greywater although the initial concentration was 4 times higher in the high strength than in the low strength source. Ultimately, excellent removals of total coliforms and *E. Coli* were determined with respectively 7.1 and 4.6 log. This provided an effluent almost free of bacteria with an average residual of only 4 counts per 100 mL for the total coliforms and undetectable levels of *E. Coli*.

To investigate the fouling properties of different types of membranes, (Chapter 5.3) it was possible to change the second reactor into a side stream membrane reactor. Under this configuration, the treated water was then filtered through tubular membranes. The data reported in Table 5.3 are average values of the different parameters measured in the effluents recovered during the experiments carried out with the tubular membranes and the high strength greywater. Once again the residual concentrations are very similar to what was seen before. The residual concentrations were 40 and 1 mg.L^{-1} for the COD and BOD respectively and 0.2 NTU for the turbidity.

Table 5.3: Side stream MBR effluent quality with high strength greywater.

	MBR2
COD (mg.L^{-1})	40 ± 15
BOD (mg.L^{-1})	1 ± 0
Turbidity (NTU)	0.2 ± 0.1
DOC (mg.L^{-1})	18 ± 3

The MCR was first studied with the low strength greywater (Table 5.1) for just over a month (Figure 5.1). However, because of a rapid fouling of the membrane with the high strength greywater it was not possible to run the MCR continuously for long periods of time (Chapter 5.3). Consequently, samples were taken every time the process was running (Figure 5.1) and average measurements of all the data are reported here (Table 5.2). The results obtained for the low strength greywater were comparable to the one with the MBR with residuals of 43 ± 14 and $3 \pm 2 \text{ mg.L}^{-1}$ for the COD and BOD respectively and $0.1 \pm 0 \text{ NTU}$ for the turbidity (Table 5.1). A minor removal of the nutrients was also observed. With the high strength greywater residual concentrations of 79 ± 18 and $9 \pm 8 \text{ mg.L}^{-1}$ for COD and BOD and 0.7 NTU for the turbidity were recorded. Finally, the MCR produced a bacteria free effluent as no coliforms or *E. Coli* were measured (Table 5.2).

On the same site and simultaneously, another project using constructed wetlands for greywater recycling was carried out by Ronnie Frazer-Williams, PhD student at Cranfield University. For this project, three constructed wetlands were studied, a horizontal flow reed bed (HFRB), a vertical flow reed bed (VFRB) and a novel system, the patent 'GROW' Green Roof Water Recycling System (WWUK, London, UK) (Appendix III; Frazer-Williams *et al.*, 2005). The constructed wetlands were tested with the low strength for over 13 months (Appendix III). Good organic removals were observed in the three technologies with average residuals below 30 mg.L⁻¹ for the COD and below 3 mg.L⁻¹ for the BOD. Poor turbidity removals were recorded in the two reed beds with 5% and 44% for the horizontal and vertical flow respectively. Alternatively, the GROW showed a good ability to remove turbidity with a residual of 0.8 NTU (96% removal) in the effluent. Limited removal of total coliforms were observed with 2.7, 4.7 and 3.4 log in the horizontal flow, vertical flow and GROW respectively corresponding to residuals between 20 and 2000 cfu/100mL. Alternatively, almost complete removal of *E. Coli* were reported in the vertical flow reed bed and the GROW with residuals of 0 and 2 cfu/100mL respectively.

The three technologies were then tested with the high strength greywater (Appendix III) for 10 months and different behaviours were observed. The horizontal flow reed bed and the GROW showed limitations when treating higher strength greywater. Indeed, BOD residuals of 51 and 71 mg.L⁻¹ and turbidity of 12 and 25 NTU were recorded for the horizontal flow reed bed and the GROW. Only the vertical flow reed bed provided a good treatment of the high strength source with residuals of 5 and 9 mg.L⁻¹ for the BOD and suspended solids and 2.2 NTU for the turbidity. Once again, only a small fraction of the biological content was removed. To demonstrate, coliforms removals were ranging from 1.7 to 3.2 log and *E. Coli* removals from 1.6 to 2.6 log.

5.1.2 Comparison

All the technologies tested here achieved a very good removal of the BOD in the low strength greywater with residuals from 1 to 3 mg.L⁻¹. However, the BOD concentration in the raw greywater was initially very low, below 20 mg.L⁻¹ on average which is enough to comply with the regulation for water recycling in the majority of the American states, Australia or Costa Rica for example (Table 2.2). On

the other hand, an excellent treatment was achieved by the MBR independently of the source to be treated. The effluent quality of 1 and 2 mg.L⁻¹ for BOD and suspended solids respectively and 0.2 NTU for turbidity observed with both the low and high strength greywater met the most stringent standards for reuse of 10 mg.L⁻¹ for BOD and suspended solids and 2 NTU for turbidity. This is consistent with the generally good greywater treatment achieved by biological systems reported in the literature (Chapter 2.4.2.4). For instance, Birks (1998) and Laine (2001) reported BOD <6 mg.L⁻¹, turbidity <4 NTU and suspended solids <9 mg.L⁻¹ for greywater treated by biological aerated filters. Friedler (2005) reported residuals of 2 mg.L⁻¹ for BOD, 8 mg.L⁻¹ suspended solids and 1 NTU for turbidity in greywater after treatment by a rotating batch contactor. The excellent performance found in this study is also typical to what can be found for MBRs. Indeed, Liu *et al.* (2005) reported concentrations of <5 and 0 mg.L⁻¹ for BOD and suspended solids respectively and <1 NTU for the turbidity in the effluent of a submerged bioreactor treating greywater. Similarly, Laine (2001) reported BOD of 1 mg.L⁻¹, turbidity of 1 NTU and suspended solids of 4 mg.L⁻¹ in the effluent of a side-stream MBR also treating greywater. Comparable performance has also been reported for MBR treating other sources. To illustrate, a Memcor system in Park Place, Georgia recycling municipal wastewater for the irrigation of a golf course achieved residual <5 mg.L⁻¹ for BOD and suspended solids (Judd, 2006). The operational parameters of the membrane bioreactor were found to be in the range of those reported for such processes (Table 5.4).

Table 5.4: Operational data of MBRs.

Reactor volume (m ³)	OLR (kg _{COD} .m ⁻³ .d ⁻¹)	MLVSS (g.L ⁻¹)	F:M (d ⁻¹)	HRT (h)	SRT (d)	Reference
0.034	0.98	8.1	0.122	9.7	68	Current study
4	0.66	10	0.066	62	-	Andersen <i>et al.</i> , 2002
1.5	0.5-1.85	3	0.17-0.67	3.6	∞ (no wasting)	Liu <i>et al.</i> , 2005
0.035	0.26	10.5	0.04	13.6	-	Laine, 2001
-	1.2-3.2	4-16	0.1-0.4	-	-	Stephenson <i>et al.</i> , 2000

The organic loading rate (OLR) of 0.98 kg_{COD}.m⁻³.d⁻¹ was just below the range of typical values for MBR reported by Stephenson *et al.* (2000). However, it was in the

range of OLR, 0.26-1.85 kg_{COD}.m⁻³.d⁻¹ reported for MBRs treating greywater (Table 5.4). Similarly, the food to micro-organisms ratio (F:M) of 0.122 d⁻¹ observed in the current study was at the lower end of typical values for MBRs but F:M reported for MBR treating greywater were generally low (Table 5.4). To illustrate, Andersen *et al.* (2002) and Laine (2001) reported F:M of 0.066 and 0.04 d⁻¹ respectively.

The good turbidity and suspended solids removal also observed in the MCR effluent (0.7 NTU for turbidity and 2 mg.L⁻¹ for suspended solids) can be explained by the presence of a membrane in the processes which will retain all solids larger than its pore size (Table 3.1). Such treatment with membrane technologies has been reported in the literature. Indeed, Liu *et al.* (2005) reported undetectable levels of suspended solids and turbidity below 1 NTU in the effluent of an MBR used for shower and bath waters recycling. Similarly, Ahn *et al.* (1998) and Hall *et al.* (1974) reported turbidity of 0 NTU in greywaters filtered through reverse osmosis and ultra-filtration membranes respectively. The membrane will also have an effect on the retention of bacteria which sizes have been reported to range from 0.1 to 40 µm (Judd, 2006). Indeed, coliforms concentrations of 4 and 0 cfu/100mL have been monitored in the effluents of the MBR and MCR respectively as well as a complete removal of the *E. Coli*. Laine (2001) described total coliforms residual concentrations of 2 and 1 cfu/100mL after the treatment of greywater by a submerged and a side stream MBRs respectively. However, the complete removal of both total coliforms and *E. Coli* in the MCR effluent can also be attributed to the operation of the UV lights required for the photo-catalytic reaction but also acting as a disinfection stage in this case.

The constructed wetlands achieved good removals of BOD and suspended solids in the low strength greywater; however, they showed limitation to remove turbidity and bacteria. The turbidity data were difficult to interpret as the values varied significantly due to blockages that occurred in the systems. When tested with the high strength greywater, both the horizontal flow reed bed and the GROW did not meet the standards for reuse for any of the parameters. Only the vertical flow reed beds met the BOD and suspended solids most stringent standards for reuse with average values of 5 and 9 mg.L⁻¹ respectively. Limited removals of the turbidity, the suspended solids and bacteria by constructed wetlands has been reported by other authors. To illustrate, Li *et al.* (2003) reported an *E. Coli* removal of only 1.5 log corresponding to a residual of 10⁴ cfu.100mL⁻¹. Similarly, Borin *et al.* (2002) observed a suspended solid removal of 20% corresponding to a residual of 20 mg.L⁻¹. With this type of treatments, the

particles and bacteria are retained when the water in which they are contained percolates through the media. In this case, it can be compared to a filtration through a sand filter as 65% of the media is composed of sand and another 25% of soil. Similarly, limited treatment was reported for such technologies. To illustrate, Itayama *et al.* (2006) monitored a suspended solids concentration of 23 mg.L^{-1} in a kitchen sink wastewater after filtration through a soil filter. Gerba *et al.* (1995) also reported concentrations of 8 mg.L^{-1} for suspended solids and $2 \times 10^6 \text{ cfu/100mL}$ for total coliforms in greywater effluent after a sand filter.

The horizontal flow reed bed and the GROW do not appear to be suitable for greywater recycling, as they could not meet all the standards for reuse in the low strength greywater especially for the removal of solids and bacteria and did not meet any of the standards with the high strength greywater. The investigation of the distribution of the values obtained for the effluent quality of the three other systems in terms of BOD, turbidity, suspended solids and total coliforms (Figure 5.2) revealed an excellent robustness of the MBR. Indeed the MBR produced a constant high quality effluent. To illustrate, with 100% of its effluent samples free of faecal coliforms, the MBR was able to meet any standards for this parameter (Table 5.5). Similarly, the MBR met all standards for BOD for all samples as the effluent concentrations was generally below 5 mg.L^{-1} whereas the most stringent BOD standard for reuse is 10 mg.L^{-1} in countries such as Israel and Spain (Table 5.5). Comparable results were also found for the turbidity with an effluent concentration constantly below 1 NTU. The MBR did not meet standards for 100% of the samples tested only in one occasion. Indeed, for the stricter standards for suspended solids and total coliforms in Spain (Table 5.5) the MBR met the standards of 3 mg.L^{-1} for suspended solids and the $2.2 \text{ cfu.100mL}^{-1}$ for total coliforms for 80% and 75% of the values respectively (Table 5.5). The MCR also showed very good compliance results (figure 5.2). Because its effluent was constantly free of micro-organisms, the MCR met all the standards for faecal and total coliforms for the totality of the samples. The MCR also achieved a good turbidity removal with 93% of the data below the typical standard of 2 NTU. As it was observed for the MBR, the MCR failed to meet the strict standard for suspended solids of 3 mg.L^{-1} required in Spain with only 79% of the values below this limit. However, it should be noted that for both systems the average concentrations of 2 mg.L^{-1} were below this standard. The main limitation of the MCR was for the compliance to the organics standard. Although the average BOD concentration in the

MCR of 9 mg.L⁻¹ was just below the most stringent standard of 10 mg.L⁻¹, only 54% of the samples were below this limit. However, 92% of the values were below the less strict standard of 20 mg.L⁻¹ required in Queensland, Australia (Table 5.5). Finally, the VFRB was found to be generally limited to comply with the standards for reuse (Figure 5.2). Indeed, none of its effluent samples could meet the 100 cfu.100mL⁻¹ for total coliforms required in Queensland, Australia. The VFRB was also found to be limited for solids removal as only 68% of the samples were below the 2 NTU standard for turbidity and 50% below the 10 mg.L⁻¹ suspended solids standard required in Israel, easily met by the MBR and MCR. However, the VFRB generally achieved better organic removal than the MCR. Indeed, 84% and 96% of the effluent samples were found to be below the 10 and 20 mg.L⁻¹ standards for BOD respectively.

Table 5.5: Compliance level of the systems for different standards.

Location / Organisation	Parameter	Standard	Compliance level (%)		
			MBR	MCR	VFRB
WHO	Faecal coliforms	1000	100	100	100
USEPA	Faecal Coliforms	14 for any sample (0 for 90%)	100	100	76 (36)
BSRIA	Faecal coliforms	nd*	100	100	36
Japan	Turbidity	2	100	93	68
	<i>E. Coli</i>	nd*	100	100	13
Israel	BOD	10	100	54	84
	SS	10	100	100	50
	Faecal coliforms	1	100	100	39
Spain, Canary Islands	BOD	10	100	54	84
	SS	3	80	79	10
	Turbidity	2	100	93	68
	Total coliforms	2.2	75	100	0
Queensland, Australia	BOD	20	100	92	96
	SS	30	100	100	100
	Total coliforms	100	100	100	0

* Not detectable.

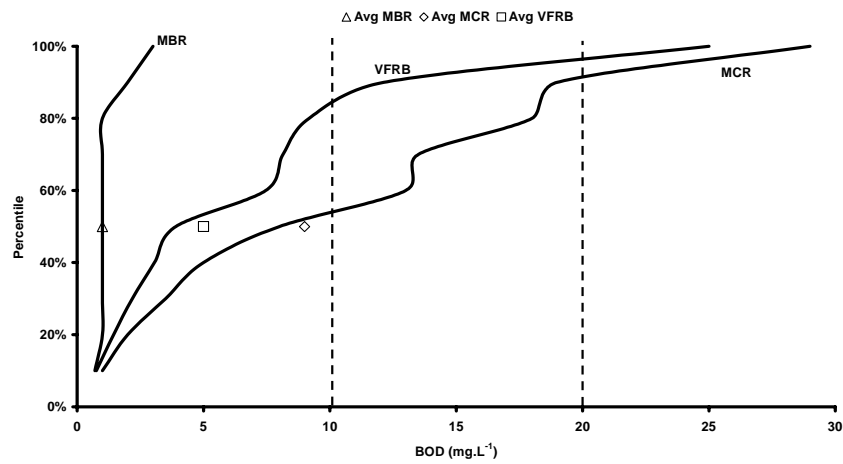

(a)

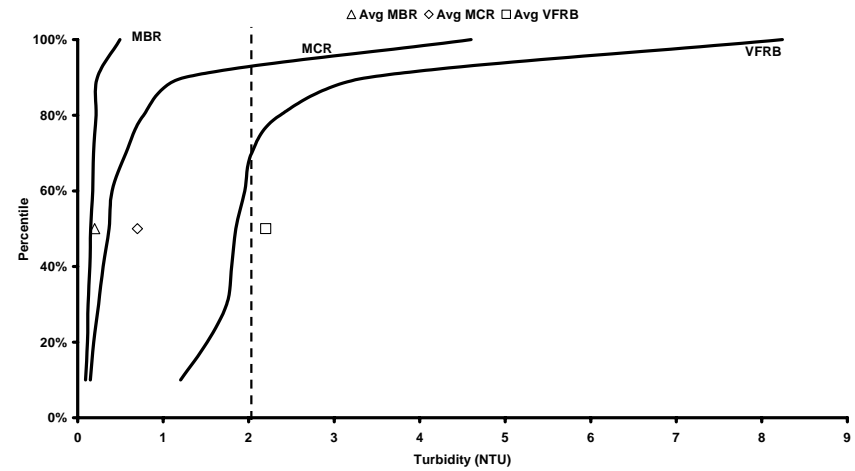

(b)

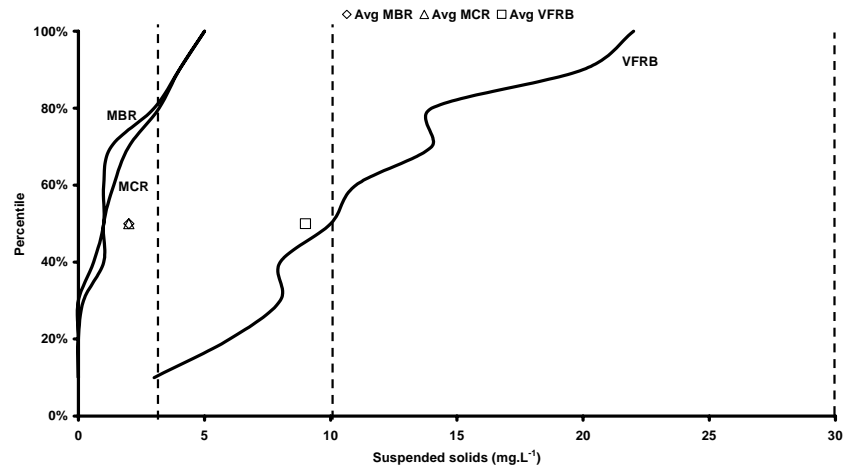

(c)

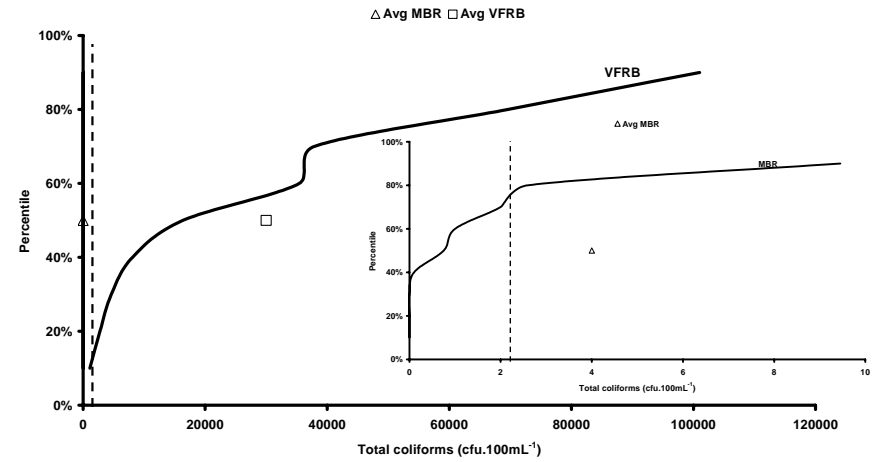

(d)

Figure 5.2: Distribution of the (a) BOD, (b) turbidity, (c) suspended solids and (d) total coliforms values from the effluent of the MBR, MCR and VFRB.

5.2 Kinetics

5.2.1 Bio-kinetics

The maximum specific growth rate, μ_{\max} and the shape factor of the Monod equation, K_s were obtained from the respirometry data (Figure 5.3), whereas the yield coefficient, Y , was determined using the parameters and performance of the pilot plant. Because this is the first investigation reporting bio-kinetics for an MBR treating greywater the findings are compared to other sources and systems. The different bio-kinetic parameters obtained from the present study are reported in Table 5.6 with results from other studies.

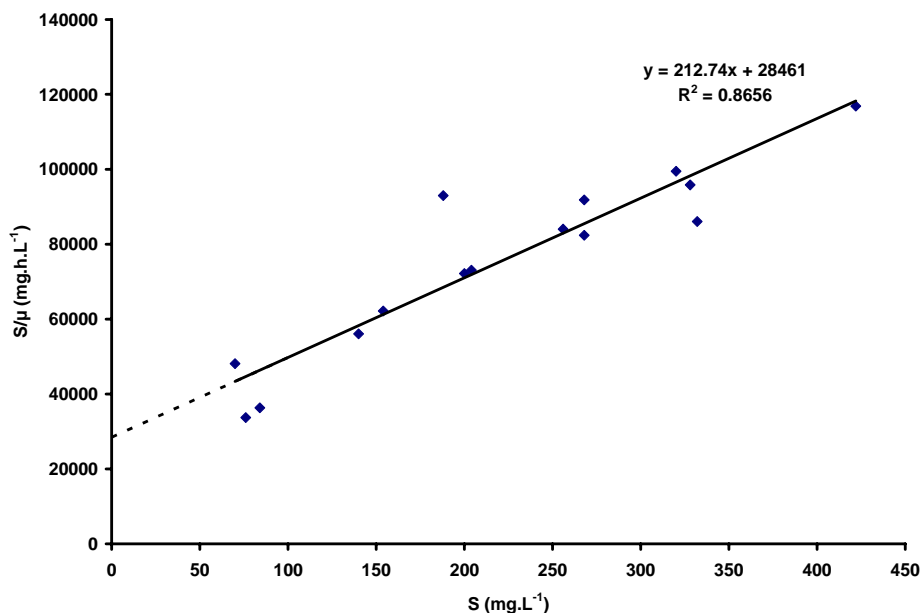

Figure 5.3: Graphical determination of K_s and μ_{\max} from the experimental data obtained by respirometry.

The yield constant, Y , determined in this study for the MBR pilot plant treating greywater was $0.19 \text{ mgMLVSS.mgCOD}^{-1}$. This is slightly lower than the typical range of $0.3\text{-}0.6 \text{ mgMLVSS.mgCOD}^{-1}$ expected for a conventional activated sludge (Metcalf and Eddy, 2003). However, it was in the middle of the range $0.05\text{-}0.46 \text{ mgMLVSS.mgCOD}^{-1}$ of yield constants reported for different MBRs treating municipal and synthetic wastewaters (Table 5.6).

Table 5.6: Bio-kinetic parameters.

System	Source	HRT (h)	SRT (d)	Y (mgMLVSS. mgCOD ⁻¹)	μ_{\max} (d ⁻¹)	K_s (mg.L ⁻¹)	Reference
MBR	Greywater	9.7	68	0.19	0.11	133.8	Present study
SM-SBR ¹	Greywater	24	360	-	16.4	551	Besançon, 2006
MBR	Municipal wastewater	11.5	30	0.36	0.91	106.5	Germain, 2004
		13.5	77	0.25	0.22	110.2	
		17	77	0.18	0.19	113.5	
MBR	Municipal wastewater	8	8	0.22	5.2	1.9	Smith <i>et al.</i> , 2003
		8	14	0.10	4.1	11.1	
		8	20	0.15	4.4	14.8	
		8	30	0.05	4.7	73.3	
MBR	Synthetic wastewater	6	2	0.457	-	-	Macomber <i>et al.</i> , 2005
		6	5	0.369	-	-	
		6	10	0.324	-	-	
		6	20	0.297	-	-	
		6	30	0.269	-	-	
MBR	Domestic wastewater	5	5	0.37	-	-	Huang <i>et al.</i> , 2001
		5	10	0.38	-	-	
		5	20	0.35	-	-	
		5	40	0.33	-	-	
		5	80	0.28	-	-	
AS ²	Domestic wastewater	-	-	0.3-0.6	0.6-6.0	10-60	Metcalf and Eddy, 2003

¹: Submerged membrane sequencing batch reactor; ² Activated sludge.

The maximum specific growth rate, μ_{\max} , and the half-saturation constant, K_s , determined in this study were 0.11 d⁻¹ and 133.8 mg.L⁻¹ respectively. Interestingly, very different values for these parameters were reported by Besançon *et al.* (2006) for submerged membrane sequencing batch reactor (SM-SBR) also treating greywater. To illustrate, μ_{\max} and K_s were 16.4 d⁻¹ and 551 mg.L⁻¹ respectively. This important difference must be due to the difference in operation of the two systems and the fact that the feed is batch fed in the SM-SBR. Values of 7.7 d⁻¹ and 563 mg.L⁻¹ for μ_{\max} and K_s respectively reported by Ng and Tan (1990) for a SBR treating domestic wastewater confirmed that such high values are connected to the SBR process and not the type of source treated.

In the Monod equation (Equation 3.6), μ_{\max} represents the maximum value for μ and K_s is related to the flatness of the growth curve as μ approaches μ_{\max} (Rozich and Gaudy, 1992). Consequently, a lower μ_{\max} in combination with a higher K_s generate a

flatter growth curve that reveal a limitation of the system in terms of biodegradation (Rozich and Gaudy, 1992). A comparison to other studies (Table 5.6) showed that μ_{\max} was lower in the present investigation than in systems treating municipal wastewater and K_s was higher. To illustrate, Germain (2004) reported a μ_{\max} of 0.22 d^{-1} and a K_s of 110.2 mg.L^{-1} for the biomass of an MBR treating municipal wastewater with a HRT of 13.5 hours and a SRT of 77 days. Alternatively, a greater difference was observed with the μ_{\max} of 4.7 d^{-1} and a K_s of 73.3 mg.L^{-1} reported by Smith *et al.* (2003) for another MBR treating municipal wastewater with a HRT of 8 hours and a SRT of 30 days. This reveals a flatter curve will be observed for the biomass from this study and the one reported by Germain (2004) in opposition to the one reported by Smith *et al.* (2003) suggesting a limited biodegradation of the substrates in the first two. It has been reported that the presence of substances such as heavy metals, non-biodegradable organics, salts, etc. in the substrate can cause such limitation (Rozich and Gaudy, 1992). To illustrate, Rozich and Gaudy (1992) compared two activated sludge plants fed with municipal wastewater with small and large fractions of industrial wastewaters respectively. The bio-kinetic constants for the systems fed with wastewater with a low fraction of industrial wastewater were $\mu_{\max} = 0.50 \text{ h}^{-1}$ and $K_s = 63 \text{ mg.L}^{-1}$ in opposition to the $\mu_{\max} = 0.18 \text{ h}^{-1}$ and $K_s = 176 \text{ mg.L}^{-1}$ obtained for the system fed with wastewater with a high fraction of industrial wastewater suggesting a flatter growth curve for the latter. This is also confirmed by the composition of the wastewaters in the studies reported by Germain (2004) and Smith *et al.* (2003). Indeed, the wastewater reported by Germain (2004) was composed at 24% of industrial wastewater in opposition to the one reported by Smith *et al.* (2003) which was essentially composed of domestic wastewater. The growth curve obtained in this study is very flat revealing an important limitation of the biodegradation of the greywater (Figure 5.4). This can be explained by the fact that heavy metals and other toxic products such as surfactants have been found in greywater. Indeed, Eriksson *et al.* (2002), Petterson *et al.* (2000) and Gutierrez *et al.* (2002) reported the high toxicity of chemicals such as heavy metals, surfactants and softeners commonly found in the domestic products composing greywater. Moreover, high COD/BOD ratio and low nutrients content indicating a poor biodegradability have also been reported. In addition, Brouwer *et al.* (1998) reported that K_s was found to be inversely proportional to substrate affinity suggesting a lower biomass substrate affinity for

higher K_s values such as the one found in this study. This confirmed that in this case it is a substrate limited process.

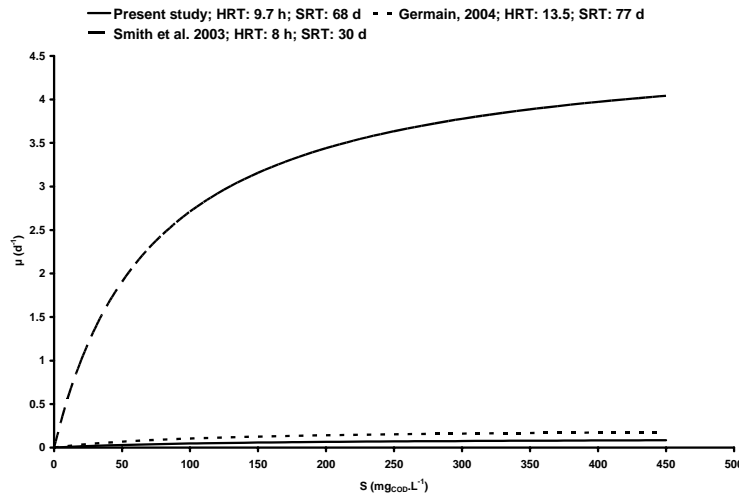

Figure 5.4: Growth curves for different systems.

5.2.2 Kinetics of catalytic reaction

The MCR responds to a continuous stirred tank reactor (CSTR) model with the reaction rate $-r$ defined as (Levenspiel, 1999):

$$-r = \frac{C_0 - C}{\tau} \quad \text{Equation 5.1}$$

Where:

- $-r$ = reaction rate ($\text{mg.L}^{-1}.\text{min}^{-1}$);
- C_0 = initial DOC concentration (mg.L^{-1});
- C = DOC concentration (mg.L^{-1});
- τ = retention time (min).

Moreover, photocatalytic reaction on which the MCR treatment process is based has been shown to be a first order reaction following the reaction rate Equation 5.2.

$$-r = K'C \quad \text{Equation 5.2}$$

Where $-r$ and C are as described above and K' (min^{-1}) is the apparent first order rate constant. Substitution of Equation 5.1 in Equation 5.2 gives Equation 5.3:

$$K' = \frac{C_0 - C}{\tau C} \quad \text{Equation 5.3}$$

It is then possible to determine K' by fitting the operational and performance parameters of the MCR obtained during the performance trials (Chapter 5.1).

Table 5.7: Determination of the apparent first order rate constant K' .

	Low strength greywater	High strength greywater
C_0 (mg.L^{-1})	11	53
C (mg.L^{-1})	4	31
τ (min)	228	228
K' (min^{-1})	0.0077	0.0031

The K' values obtained for the low and high strength greywater (Table 5.7) are similar to the ones reported in the literature for photocatalytic oxidation with TiO_2/UV . Indeed, Parsons *et al.* (2000) reported K' of 0.0034-0.0084 min^{-1} also for the treatment of greywater with initial DOC concentration between 25 and 660 mg.L^{-1} . Similarly, Chen and Jenq (1998) reported K' of 0.0013-0.0027 min^{-1} for the treatment of municipal wastewater with initial DOC concentration between 0.302 and 0.763 mg.L^{-1} .

Batch experiments were then carried out to have a more detailed view of the kinetic of reaction of the photocatalytic oxidation of greywater. The evolution of the DOC concentration with time in five dilutions of greywater when being treated with TiO_2/UV was monitored (Figure 5.5). For all greywaters, a sharp decrease of the DOC concentration was observed in the first 5 minutes. After this, the DOC concentration stayed constant for most of the samples for the rest of the duration of the experiments. To illustrate, in the sample GW3, the DOC concentration decreased from 38.9 to 16.0 mg.L^{-1} in the first 5 minutes and then stabilised to 14.3 mg.L^{-1} after an hour. Only for the highest strength greywater tested, a further significant decrease of the DOC concentration could be observed after the initial 5 minutes. To illustrate, in the sample GW5, the DOC concentration decreased from 79.5 to 39.8 mg.L^{-1} in the first 5 minutes and then decreased to 32.3 mg.L^{-1} in the next hour.

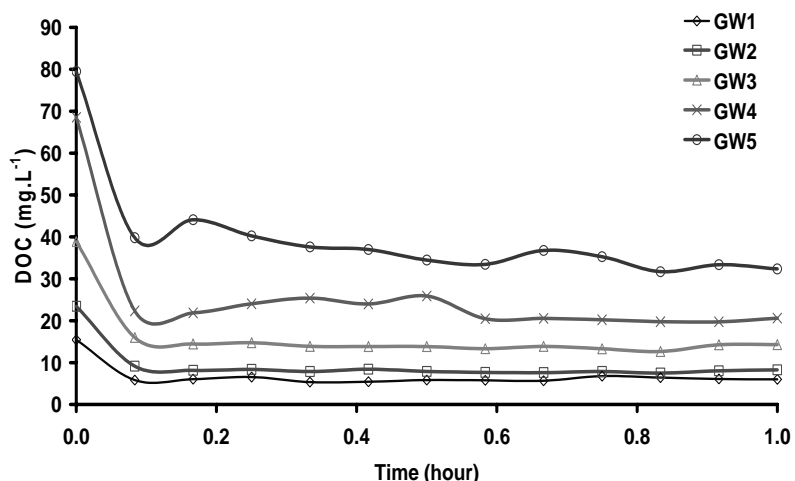

Figure 5.5: Evolution of the DOC concentration with time in greywaters treated by photocatalytic oxidation.

These results showed that the photocatalytic oxidation of the organic carbons in greywater was fairly quick and mostly occurred in the first 5 minutes of the treatment. Interestingly, the DOC removal was between 60 and 70 % independently of the initial DOC concentration. This confirms the results found previously with other chemical treatment processes (Chapter 4) suggesting that it exists a recalcitrant fraction that cannot be removed by such technologies.

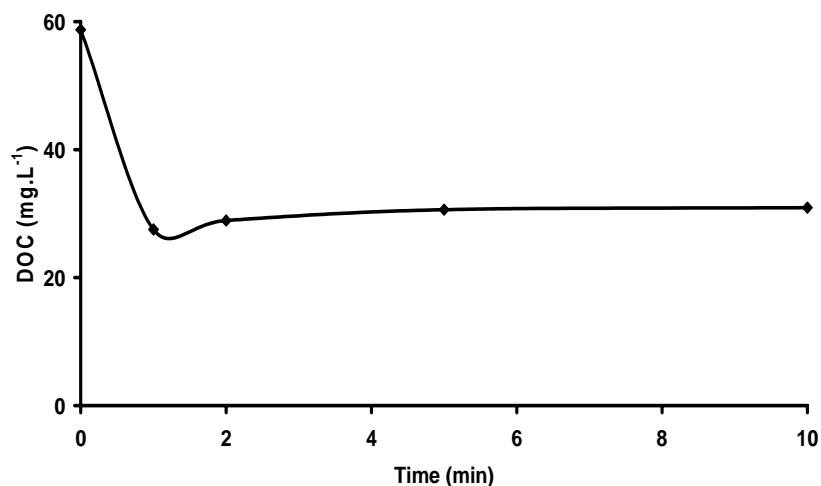

Figure 5.6: Evolution of the DOC concentration in the first 10 minutes of treatment of greywater by photocatalytic oxidation.

However, to assess the kinetic of the photocatalytic oxidation it is necessary to be able to observe an evolution of the DOC concentration with time. Another test was then performed with the samples to be taken earlier to monitor the evolution of the DOC in

the first 5 minutes (Figure 5.6). The results obtained were similar to the ones observed before. Indeed, the DOC decrease sharply in the first minute and then stabilised. To illustrate, the DOC concentration decreased from 58.7 to 27.5 mg.L⁻¹ in the first minute and was then constant around 30 mg.L⁻¹ for the next ten minutes. It is then not possible to calculate the kinetic parameter directly but it is possible to obtain an estimation from the results found. Indeed, a minimum rate can be calculated by considering that 31.2 mg.L⁻¹ of DOC have been removed in 1 minute. It is then possible to determine K' from Equation 3.11 (Table 5.8).

Table 5.8: Determination of the apparent first order rate constant K' for batch experiments.

Sample	1	2	3	4	5	6
C ₀ (mg.L ⁻¹)	79.49	68.53	58.73	38.87	23.44	15.43
C (mg.L ⁻¹)	39.8	32.36	27.5	16	9.155	5.836
K' (min ⁻¹)	0.691	0.750	0.758	0.887	0.940	0.972

In this case, the K' values are two orders of magnitude higher than the ones previously found suggesting that the apparent reaction rate is much quicker than the retention time in the reactor.

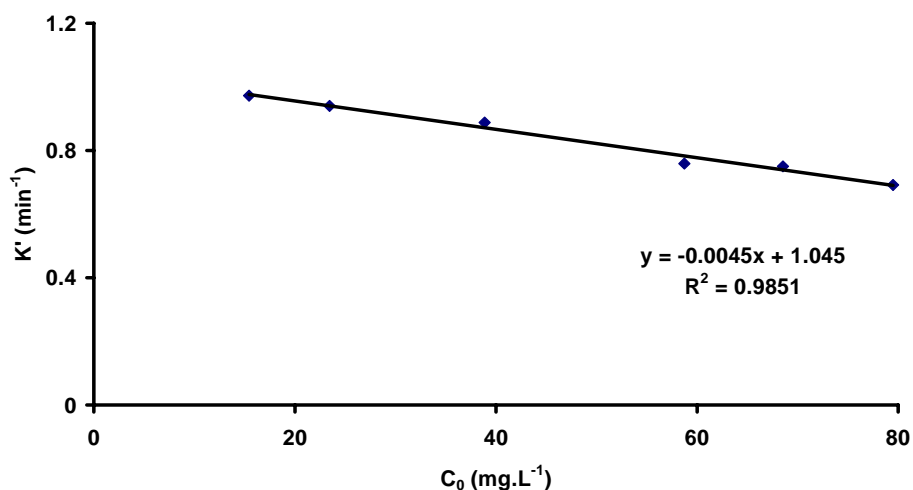

Figure 5.7: Correlation between the apparent first order rate constant K' and the initial DOC concentration.

The apparent first order rate constant K' was found to decrease when the initial DOC concentration increased (Figure 5.7). Because the concentration of TiO₂ was the same for all greywater concentration tested, the proportion of adsorption site in comparison

to the concentration of pollutant in fact decreased suggesting that the reaction rate was limited by the adsorption reaction and not the photocatalytic oxidation reaction.

It is then possible to calculate the actual reaction time, τ , by fitting the results obtained in Equation 5.3. Reaction times of 2.2 and 0.9 minutes were found for the treatment of the low and high strength greywater respectively. These results show that the photocatalytic oxidation reaction occurs very quickly, much quicker than the retention time in the reactor (HRT = 3.8 hours). However, it would not be possible to greatly reduce the retention time in the reactor as the MCR is a membrane process and in this case the retention time is directly linked to the flux. To illustrate, if a conservative retention time of 10 minutes in comparison to the 0.9 minute reaction time is chosen, for the same MCR (9-litre reactor; 0.157 m² membrane), the flux would be 344 L.m⁻².h⁻¹. This is not achievable as the membrane would foul instantly. Alternatively, it is possible to reduce the flux by increasing the membrane surface area. For the same conditions as before and a chosen flux of 15 L.m⁻².h⁻¹, the required surface area would be 3.6 m² which is also not sensible for a small footprint system.

The results of the kinetic investigation showed that the reaction in the MCR is limited by the mass transfer during the adsorption phase and by the membrane. To optimise the process it is necessary to adapt the reactor in order to maximise the mass transfer and limit the fouling to increase the flux.

5.3 Fouling studies

5.3.1 Short term fouling

In the MBR, the investigation of the fouling with the flux step method in the ceramic membranes revealed that little fouling occurred (Figure 5.8). Indeed, for both membranes with the different air lift velocities tested the fouling rates generally stayed below 1 mbar.min⁻¹ for fluxes up to 60 L.m⁻².h⁻¹ (Figure 5.9). Moreover, in the same conditions less fouling was generally observed in the membrane with the bigger pore size. To illustrate, at the highest flux tested, 70 L.m⁻².h⁻¹, fouling rates of 0.55 and 0.71 mbar.min⁻¹ with an air lift velocity of 1.22 m.s⁻¹ and of 0.31 and 0.44 mbar.min⁻¹ with an air lift velocity of 1.95 m.s⁻¹ were observed for the membranes with a MWCO of 300 and 150 kDa respectively (Figure 5.9).

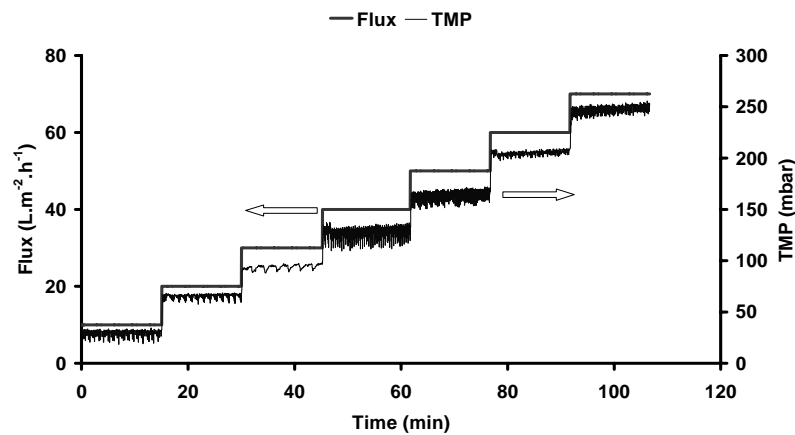
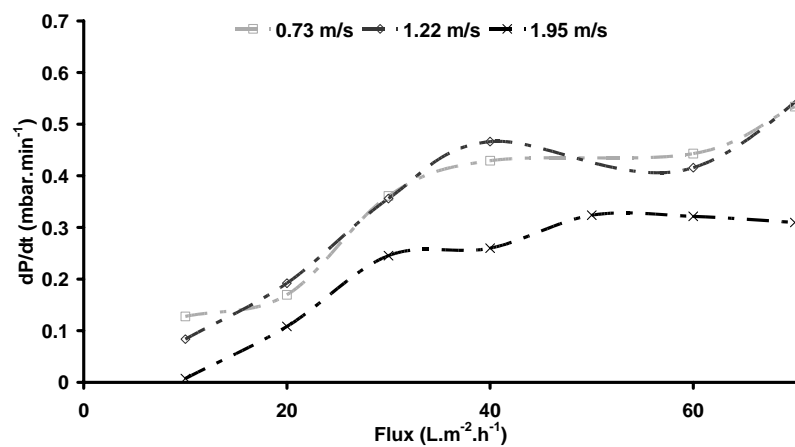
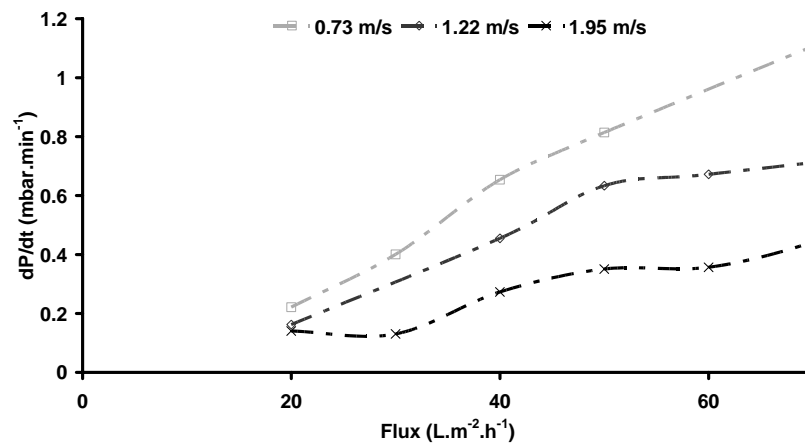

Figure 5.8: Flux step test.



(a)



(b)

Figure 5.9: Fouling rates for different air velocities U_{air} in the MBR with the (a) 300 kDa and (b) 150 kDa ceramic membranes.

It was also found that the fouling rates increased when the air lift velocity decreased. This was more obvious in the case of the membrane with MWCO of 150 kDa than the other one. For instance, at a flux of $60 \text{ L.m}^{-2}.\text{h}^{-1}$, fouling rates of 0.32, 0.42 and 0.44 $\text{mbar}.\text{min}^{-1}$ for the 300 kDa MWCO membrane and of 0.36, 0.67 and 0.96 $\text{mbar}.\text{min}^{-1}$

for the 150 kDa MWCO membrane were recorded at air lift velocities of 1.95, 1.22 and 0.73 $\text{m}\cdot\text{s}^{-1}$ respectively (Figure 5.9). It should be noted that for both membranes and in all the conditions tested no sharp increase of the fouling rate indicative of a critical flux was observed.

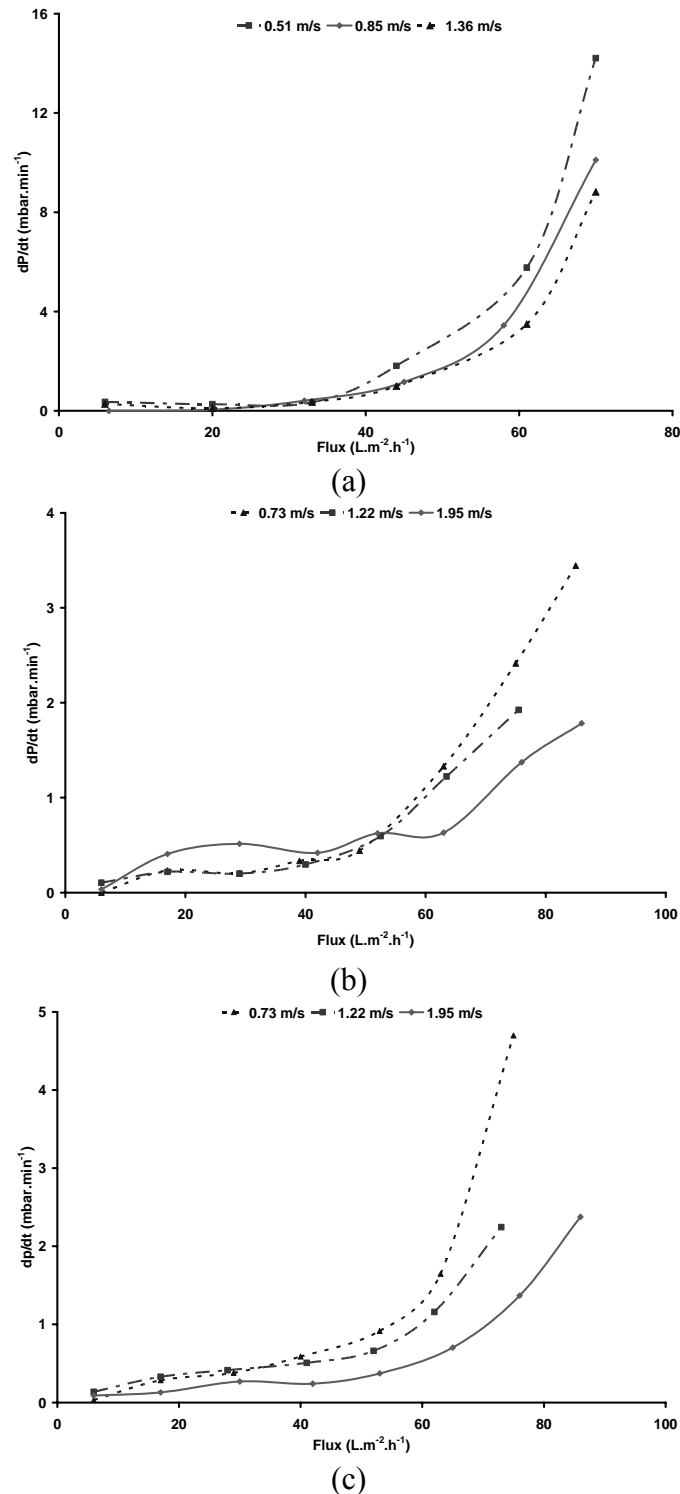

Figure 5.10: Fouling rates for different air lift velocities U_{air} in the MCR with the (a) polymeric and the (b) 300 kDa and (c) 150 kDa MWCO ceramic tubular membranes.

In the case of the MCR, a similar trend was observed for the three membranes and the different air lift velocities tested. Indeed, the fouling rates were low and fairly constant for the lower fluxes and then increased rapidly from a given flux, defined as the critical flux (Figure 5.10). To illustrate, in the case of the polymeric membrane with an air lift velocity of 1.36 m.s^{-1} , fouling rates of 0.28, 0.10 and $0.36 \text{ mbar.min}^{-1}$ were observed for fluxes of 6, 20 and $33 \text{ L.m}^{-2}.\text{h}^{-1}$ respectively (Figure 5.10a). For fluxes above $42 \text{ L.m}^{-2}.\text{h}^{-1}$, the fouling rates then increased rapidly. For instance, fouling rates of 3.49 and $8.82 \text{ mbar.min}^{-1}$ were found for fluxes of 61 and $70 \text{ L.m}^{-2}.\text{h}^{-1}$ respectively. The results obtained with the polymeric membrane when the MCR was used batch and continuous are surprisingly different. Indeed, in batch mode (Chapter 4.3) no fouling was observed. To illustrate, fouling rates of 0.1-0.8 and $0.1\text{-}0.4 \text{ mbar.min}^{-1}$ were recorded at air velocities of 0.5 and 1.25 m.s^{-1} respectively for fluxes up to $55 \text{ L.m}^{-2}.\text{h}^{-1}$. In contrast, during the continuous assessment, fouling rates reached 2.3 and $3.8 \text{ mbar.min}^{-1}$ at a flux of $55 \text{ L.m}^{-2}.\text{h}^{-1}$ for air velocities of 0.51 and 1.36 m.s^{-1} respectively revealing a much more important fouling in this case. Critical fluxes of 37 and $42 \text{ L.m}^{-2}.\text{h}^{-1}$ were thus determined for the air velocities of 0.51 and 1.36 m.s^{-1} respectively (Table 5.10). Moreover, as it was observed with the MBR, for higher fluxes the fouling rates were generally lower with higher air lift velocities. To illustrate, in the case of the 300 kDa MWCO ceramic membrane at a flux of $76 \text{ L.m}^{-2}.\text{h}^{-1}$, fouling rates of 1.37, 1.93 and $2.45 \text{ mbar.min}^{-1}$ were determined for air lift velocities of 1.95, 1.22 and 0.73 m.s^{-1} (Figure 5.10b). The lower critical flux observed with the polymeric membrane than with the ceramic membranes suggested that polymeric material exhibit a greater inherent fouling propensity. For example, the critical flux with an air lift velocity around 0.8 m.s^{-1} were 53, 49 and $37 \text{ L.m}^{-2}.\text{h}^{-1}$ for the 150 and 300 kDa ceramic membranes and the polymeric membrane respectively (Table 5.10). In addition, for the same conditions of air lift velocities, the fouling rates obtained for fluxes above the critical flux were generally higher in the polymeric membrane than in the ceramics confirming that more fouling occurred in the polymeric membrane. To illustrate, in the case of an air lift velocity around 1.3 m.s^{-1} and at a flux of $60 \text{ L.m}^{-2}.\text{h}^{-1}$, fouling rates of 3.2, 1.0 and 1.1 were found for the polymeric membrane and the 300 and 150 MWCO ceramic membranes respectively. This trend was also reported by Alvarez-Vazquez (2005) who investigated both types of membranes in a side-stream MBR for the treatment of municipal wastewater.

Indeed, Alvarez-Vazquez (2005) reported critical fluxes of 36 and $>60 \text{ L.m}^{-2}.\text{h}^{-1}$ for a polymeric and a ceramic membranes respectively trialled in the same conditions.

A comparison of the results obtained for the two systems revealed that for fluxes below $50 \text{ L.m}^{-2}.\text{h}^{-1}$, the fouling rates were very low and fairly similar (Figure 5.11). To illustrate, at an air lift velocity of 1.22 m.s^{-1} , fouling rates of 0.21 and $0.36 \text{ mbar.min}^{-1}$ in the 300 kDa MWCO membrane and of 0.39 and $0.31 \text{ mbar.min}^{-1}$ in the 150 kDa MWCO membrane were observed for a flux of $30 \text{ L.m}^{-2}.\text{h}^{-1}$ in the MCR and MBR respectively. Alternatively, for fluxes above $50 \text{ L.m}^{-2}.\text{h}^{-1}$, the fouling was found to be much more important in the MCR than in the MBR (Figure 5.11). For instance, at an air lift velocity of 1.22 m.s^{-1} , fouling rates of 2.41 and $0.63 \text{ mbar.min}^{-1}$ in the 300 kDa MWCO membrane and of 4.70 and $0.74 \text{ mbar.min}^{-1}$ in the 150 kDa MWCO membrane were observed for a flux of $75 \text{ L.m}^{-2}.\text{h}^{-1}$ in the MCR and MBR respectively.

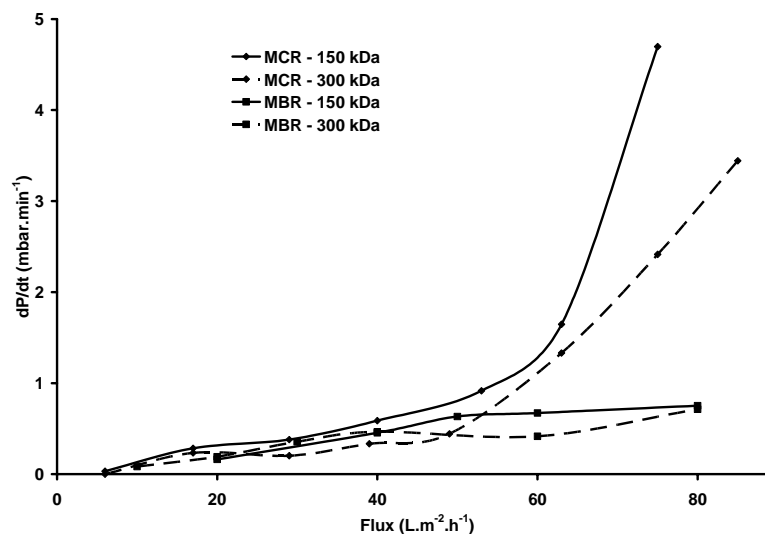

Figure 5.11: Comparison of the fouling rate in the MCR and MBR with the 300 kDa and 150 kDa ceramic tubular membranes for an air lift velocity of 1.22 m.s^{-1} .

The influence of the air velocity on the fouling rate and consequently on the critical flux observed for both systems in this study was also reported in other studies. Indeed, Le Clech *et al.* (2003) reported critical fluxes of 9, 19 and $32 \text{ L.m}^{-2}.\text{h}^{-1}$ for air velocities of 0.02, 0.11 and 0.2 m.s^{-1} respectively in a submerged tubular membrane in an MBR treating municipal wastewater. Similarly, Psoch and Schiewer (2005) reported critical fluxes of 10 and $16 \text{ L.m}^{-2}.\text{h}^{-1}$ for air velocities of 1.2 and 2.5 m.s^{-1}

respectively in a tubular membrane in a side-stream MBR also treating municipal wastewater. This increase of the critical flux with the increase of the velocity was also observed in a system with the recirculation generated by a pump instead of air lift. To illustrate, critical fluxes of 10.5 and 16 L.m⁻².h⁻¹ were reported for liquid cross flow velocities of 0.21 and 0.35 m.s⁻¹ respectively in a tubular membrane in a side-stream MBR treating municipal wastewater (Le Clech *et al.*, 2003).

Table 5.9: Comparison of critical flux, J_c , for different systems.

System type - volume	Membrane type - pore size (μm)	Source	MLSS (g.L ⁻¹)	U_{air} (m.s ⁻¹)	J_c (L.m ⁻² .h ⁻¹)	Reference
Subm. ¹ MBR - 45 L	Tub. ³ - 0.2	Mun. ⁵	3	0	6	Le Clech <i>et al.</i> , 2003
				0.02	9	
				0.07	16	
				0.11	19	
				0.15	25	
				0.2	32	
				0.25	26	
SS ² MBR - 45 L	Tub. - 0.2	Mun.	3	0.05 ⁷	10.5	
				0.21 ⁷	10.5	
				0.35 ⁷	16	
SS MBR	Tub. - 0.2	Mun	10	1.2	10	Psoch and Schiewer, 2005
				2.5	16	
				0.16	24	
SS MBR - 40 L	Tub. - 0.03	Mun.	7	0.22	36	Alvarez-Vazquez, 2005
				0.28	36	
				0.73	>70	
SS MBR - 34 L	Tub. - 150 ⁴	Grey Water	8.8	1.22	>70	
				1.95	>70	
				0.73	>70	
				1.22	>70	
				1.95	>70	
SS MCR - 9 L	Tub. - 300 ⁴	Grey Water	5 ⁶	0.73	53	Current study
				1.22	55	
				1.95	60	
				0.73	49	
				1.22	49	
				1.95	63	
				0.51	37	
Tub. - 0.05				0.85	42	
				1.36	42	

¹: Submerged; ²: Side stream; ³: Tubular; ⁴: MWCO in kDa; ⁵: Municipal; ⁶: TiO₂ coccentration; ⁷: liquid cross flow velocity.

The fact that no significant increase of the fouling rates was observed in the case of the MBR with both membranes suggests that the critical flux was not reached for the flux tested (Figure 5.8) and consequently it should be above $70 \text{ L.m}^{-2}.\text{h}^{-1}$ the highest flux tested. The critical fluxes reported by Le Clech *et al.* (2003) and Alvarez-Vazquez (2005) for MBRs treating municipal wastewater were generally lower ($6\text{-}36 \text{ L.m}^{-2}.\text{h}^{-1}$) than the ones found in study for the MBR treating greywater (Table 5.9). A reason for such difference can be found in the fact that they used lower air velocities than the ones used in this study and as it was shown above the critical flux increase with the air velocity. However, for air velocities of 1.2 and 2.5 m.s^{-1} , comparable to the ones used in this study, Psoch and Schiewer (2005) reported critical fluxes of only 10 and $16 \text{ L.m}^{-2}.\text{h}^{-1}$ respectively. This suggests that less fouling occurred in the MBR treating greywater than the systems treating municipal wastewater.

Table 5.10: Comparison of the fouling rates before and after the critical flux in different systems.

System type - volume	Membrane		J_c ($\text{L.m}^{-2}.\text{h}^{-1}$)	dP/dt before J_c	dP/dt after J_c	Reference	
	Type	Pore size (μm)					Material
Subm. ¹ MBR	FP ³	0.4	Polym. ⁶	25	<0.1	0.1-1.2	Ndinisa <i>et al.</i> , 2004
SS ² MBR - 40 L	Tub. ⁴	0.03	Polym.	36	0.09-0.14	0.37-12.6	Alvarez-Vazquez, 2005
	Tub.	1	Ceram. ⁷	>60	0.39-0.49	-	
SS MBR - 34 L	Tub.	150 ⁵	Ceram.	>70	0.36-1.2	-	Current study
	Tub.	300 ⁵		>70	0.32-0.44	-	
SS MCR - 9 L	Tub.	150 ⁵	Ceram.	53-60	0.1-0.66	0.6-4.7	
	Tub.	300 ⁵		49-63	0.1-0.63	0.6-3.4	
	Tub.	0.05	Polym.	37-42	0.1-0.40	1-14	

¹: Submerged; ²: Side stream; ³: Flat plate; ⁴: Tubular; ⁵: MWCO in kDa; ⁶: Polymeric; ⁷: Ceramic.

In the case of the MCR, for all the membranes tested the critical fluxes were found to vary between 37 and $63 \text{ L.m}^{-2}.\text{h}^{-1}$ for air velocities varying between 0.55 and $1.95 \text{ L.m}^{-2}.\text{h}^{-1}$. These were lower than the critical fluxes obtained for the MBR investigated in this study for the same air velocities. Moreover, the critical fluxes found with the

different membranes in the MCR were found to be equal or higher than ones observed for MBRs treating municipal wastewater (Table 5.9). This also suggests that less fouling occurred in the MCR than in the system treating municipal wastewater. However, the study of the fouling rates obtained for fluxes below the critical flux showed that these fouling rates are generally higher for the MCR and the MBR of this study (Table 5.10). To illustrate, before the critical flux, fouling rates of 0.1-1.2 mbar.min⁻¹ were observed for the MCR and MBR treating greywater. In contrast, for MBRs treating municipal wastewater, the fouling rates varied between 0.1 and 0.5 mbar.min⁻¹. Interestingly, the highest fouling rates of 0.39-0.49 mbar.min⁻¹ found for the systems with municipal wastewater were with the ceramic membrane (Table 5.10) which had a higher critical flux. This can be explained by the fact that the systems with higher critical fluxes were indeed trialled at higher fluxes and it is likely that at higher fluxes even under sub-critical conditions more fouling occurred.

5.3.2 Long term fouling

In the MBR, the two ceramic tubular membranes with MWCO of 150 and 300 kDa were investigated (Figure 5.12) at a flux of 60 L.m⁻².h⁻¹ and then the 150 kDa MWCO membrane was assessed with two other fluxes, 70 and 80 L.m⁻².h⁻¹. At a flux of 60 L.m⁻².h⁻¹, the evolution of the TMP was relatively similar for the two membranes tested. Indeed, critical time were 365 and 335 hours for the 150 and 300 MWCO membranes respectively (Table 5.11). For the 150 MWCO membrane, as expected t_c decreased when the flux increased. To illustrate, t_c of 365, 69 and 0.8 hours were found for fluxes of 60, 70 and 80 L.m⁻².h⁻¹ respectively. Such trend was also reported by Brookes *et al.* (2006) in a submerged MBR treating synthetic industrial wastewater. Indeed, Brookes *et al.* (2006) observed a decrease of t_c from 192 to 137 and then 74 hours when increasing the flux from 4, 6 and 8 L.m⁻².h⁻¹ respectively (Table 5.11).

A comparison of the results found in the current study to values obtained for similar systems treating municipal wastewater reported in the literature suggests that the ceramic membranes tested here fouled less quickly. Indeed, for a side-stream MBR with a tubular membrane, Ognier *et al.* (2004) reported a critical time of 550 hours similar to the one observed for the 150 kDa membrane at a flux of 60 L.m⁻².h⁻¹ but for a flux 6 times smaller (Table 5.11). Similarly, Wen *et al.* (2004) reported a fairly high

critical time of 1220 hours but this was for hollow fibre membranes in a side-stream MBR run at a flux of $22 \text{ L.m}^{-2}.\text{h}^{-1}$ (Table 5.11). The MCR showed completely different results. Indeed, the polymeric membrane tested in the MCR was fouled very quickly (Figure 5.13). To illustrate, a critical time of 10 hours was determined for a flux of $15 \text{ L.m}^{-2}.\text{h}^{-1}$. Even for a flux as low as $5 \text{ L.m}^{-2}.\text{h}^{-1}$ the critical time was still fairly low at a value of 48 hours.

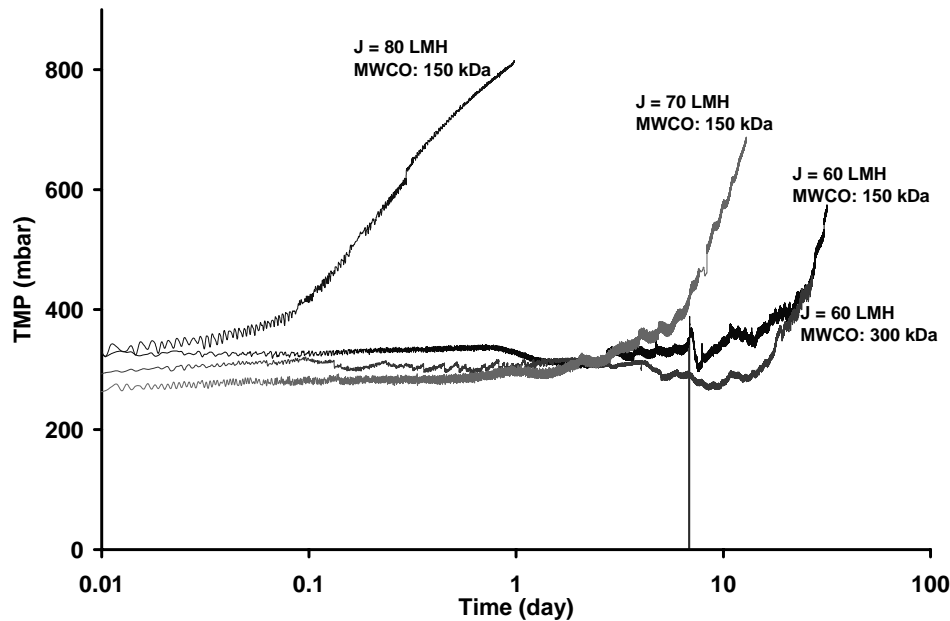

Figure 5.12: Evolution of the TMP with time for the ceramic tubular membranes in the MBR at different fluxes.

Table 5.11: Comparison of the critical time, t_c , for different systems (Adapted from Brookes *et al.* (2006)).

System type - volume	Membrane type - pore size (μm)	Source	Flux ($\text{L.m}^{-2}.\text{h}^{-1}$)	MLSS (g.L^{-1})	t_c (h)	dP/dt before t_c	dP/dt after t_c	Reference
SS ¹ MBR - 20 L	Tub. ³ - 0.05	Syn. Mun. ⁶	10	1.8	550	<0.0083	0.45	Ognier <i>et al.</i> , 2004
SS MBR - 50 L	HF ⁴ - 0.22	Syn. Mun.	22	5-6	1220	0.0018	0.71	Wen <i>et al.</i> , 2004
Subm. ² MBR - 40 L	Tub. - 0.03	Syn. Ind. ⁷	4	6	192	0.0022	0.14	Brookes <i>et al.</i> , 2006
			6		137	0.0051	0.031	
			8		74	0.0049	0.085	
			60		365	0.0017	0.009	
SS MBR - 34 L	Tub. - 150 ⁵	Grey Water	70	8.8	69	0.012	0.024	Current study
			80		0.8	0.25	0.38	
	Tub. - 300 ⁵		60		335	0.00071	0.007	
SS MCR - 9 L	Tub. - 0.05	Grey Water	5	5 ⁸	48	0.021	0.029	
			15		10	0.027	0.087	

¹: Side stream; ²: Submerged; ³: Tubular; ⁴: Hollow fiber; ⁵: MWCO in kDa; ⁶: Synthetic municipal; ⁷: Synthetic industrial; ⁸: TiO_2 concentration.

Investigation of the fouling rates before and after the critical time confirmed the tendency of the membrane in the MCR to foul more than in MBRs. To illustrate, fouling rates of 0.02-0.03 mbar.min⁻¹ were found for the MCR before the critical time. In contrast, for MBRs treating synthetic municipal and industrial sources before the critical time, fouling rates of 0.0018-0.0083 mbar.min⁻¹ were reported (Table 5.11). Similar results were found for the MBR in this study. Indeed, fouling rates of 0.0007-0.012 mbar.min⁻¹ were observed before the critical time at fluxes of 60 and 70 L.m⁻².h⁻¹ in both membranes. However, fairly high fouling rates were recorded at a flux of 80 L.m⁻².h⁻¹ in the 150 kDa MWCO membrane. To illustrate, fouling rates of 0.25 and 0.38 mbar.min⁻¹ were found before and after the critical time respectively (Table 5.11). The high fouling rates found as well as the small difference between the fouling rate before and after the critical time suggest that at such high flux there was no real 'no fouling' period and the fouling increased continuously over the experiments. The critical time (defined in Chapter 3.2.3.2) is an indication of the duration before which fouling starts occurring; however, the systems could be run longer before the membranes were severely fouled generally observed when the TMP reached 600 mbar.

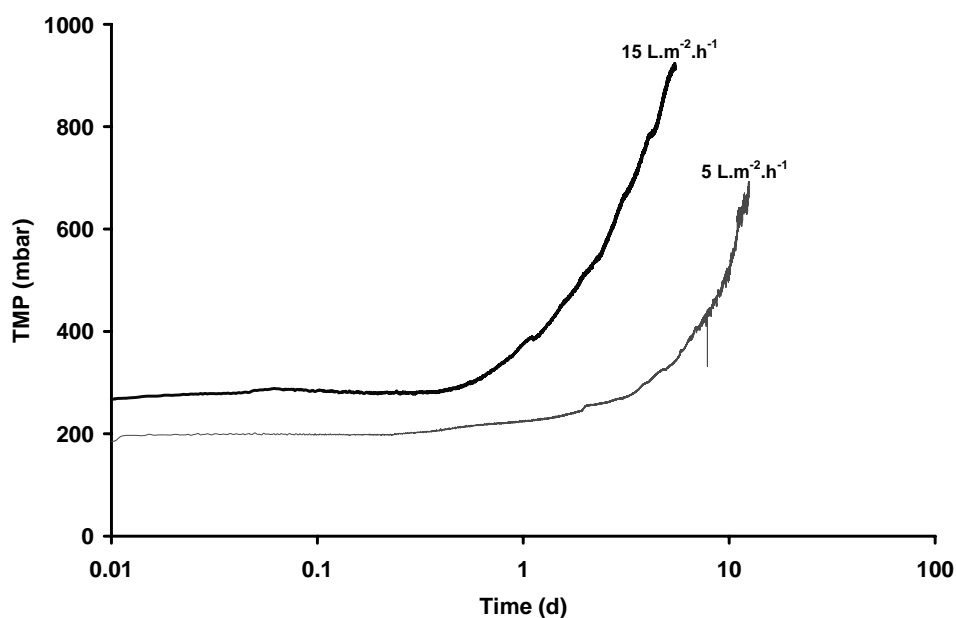

Figure 5.13: Evolution of the TMP with time for the polymeric tubular membrane in the MCR at fluxes of 5 and 15 L.m⁻².h⁻¹.

Several approaches have been taken to try to minimize the fouling in the MCR. The first option tested was the increase of the shear in the recirculation loop to limit the

build up of the cake layer by increasing the air lift velocity. Because this did not limit the fouling, trials were carried out with the recirculation generated with a pump and with the pump and the air simultaneously. Even such systems did not reduce the fouling and on the contrary enhanced the foaming in the reactor. The second option tested was a reduction of the flux to increase the retention time in the reactor and ensure a longer treatment. The flux was reduced from $15 \text{ L.m}^{-2}.\text{h}^{-1}$ initially chosen to $5 \text{ L.m}^{-2}.\text{h}^{-1}$ corresponding to a change of the HRT from 3.8 hours to 11.5 hours similar to the 9.8-hour HRT of the MBR. The longer retention time improved the filtration conditions and the critical time rose from 10 hours at $15 \text{ L.m}^{-2}.\text{h}^{-1}$ to 48 hours at $5 \text{ L.m}^{-2}.\text{h}^{-1}$ (Figure 5.13). However, the operation of the MCR was still limited as the TMP reached 688 mbar and the flux dropped after 12.5 days. The last options tested were regular backwashing and relaxation of the membrane. Once again, a limited improvement occurred with the critical time increasing to about a week but the system had to be stopped after another week due to the TMP reaching 900 mbar. No option provided a significant amelioration of the filtration conditions that would have allowed operation of the system for several weeks without maintenance for the membrane.

5.3.3 Discussion

Results of both short and long term fouling studies showed that more and quicker fouling occurred in the chemical system than in the biological system. It was also observed that generally higher critical fluxes and times were found for the MBR treating greywater than for the ones treating municipal wastewater suggesting less fouling occurred in the membrane of the system studied in the current work. Studies on membrane fouling in MBRs identified the size of foulants to have an important impact on their fouling tendencies (Judd, 2006). In terms of size, the mixed liquor in MBRs can be divided in three fractions: suspended solids, colloids and solubles. Attention has been particularly drawn to two sub-fractions, the extracted extracellular polymeric substances (EPS), construction materials for microbial aggregates such as biofilms, flocs and activated sludge liquor composed of macromolecules such as proteins, carbohydrates and nucleic acids and the soluble microbial products (SMP) that represents clarified biomass with remaining substrate not yet treated (Judd, 2006). Indeed, EPS and SMP have been shown to greatly contribute to the membrane fouling

in MBRs (Judd, 2006). In systems operated at constant flux, fouling mechanisms have been defined to occur in three stages (Figure 5.14). The first stage is a phase of conditioning during which deposition of residues, passive adsorption of colloids and organics and pore blocking take place due to interactions between the membrane surface and the EPS and SMP. During the second phase of slow fouling the membrane surface is mostly covered by SMP that block pores and form a gel layer that it is thought to provide nutrients for biofilm formation. This also promotes the attachment of biomass flocs that form a cake layer. These phenomena alter the permeability of the membrane and consequently affect the flux. Because the fouling does not occur uniformly on the surface of the membrane, permeation is promoted in less fouled regions and then the local flux exceeds the critical flux. This triggers a rapid increase of the fouling rates and thus a sharp rise of the TMP (Figure 5.14; Judd, 2006).

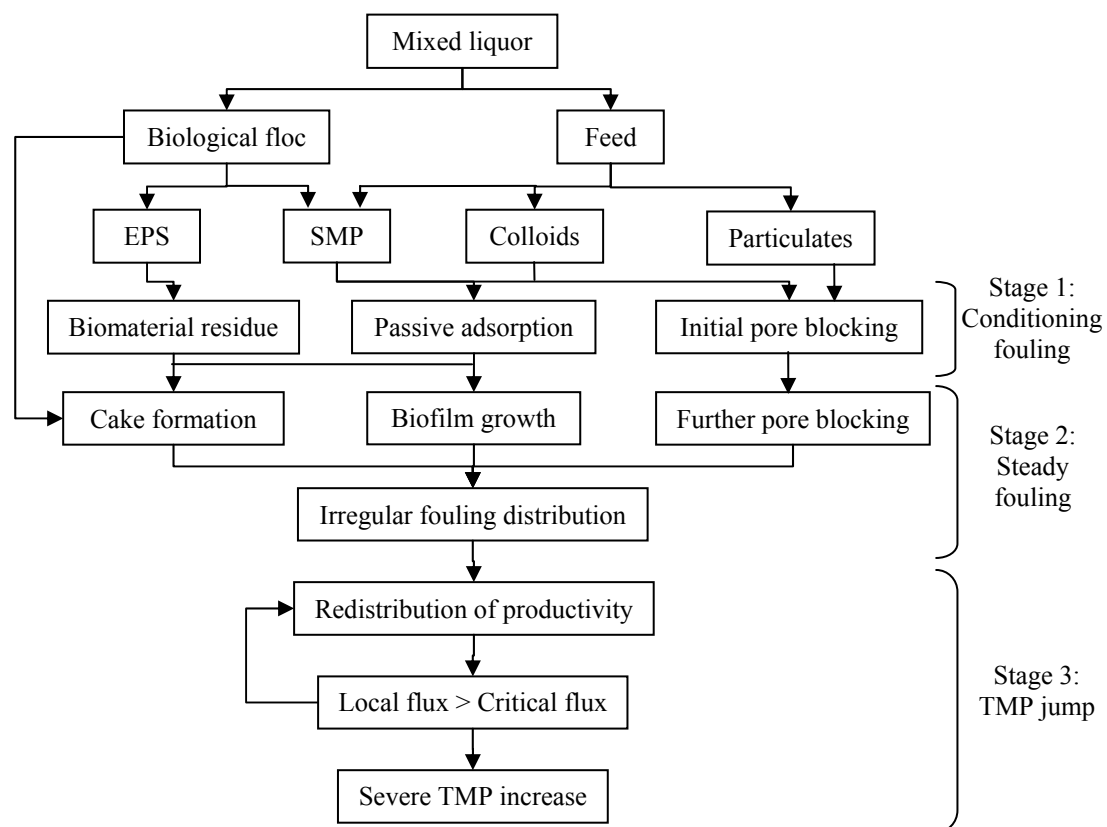

Figure 5.14: Fouling mechanisms for MBR (adapted from Judd, 2006).

According to this, the propensity of mixed liquors to foul membrane was generally evaluated by measuring the concentration of proteins and carbohydrates in the EPS

and SMP, the capillary suction time or viscosity (Table 5.12). Comparison of these parameters showed that they were all lower in the case of the MBR treating greywater than in the MBR treating municipal wastewater (Table 5.12). To illustrate, carbohydrate and protein concentrations in the extracted EPS of 4.4 and 21.6 mg.gSS⁻¹ and 6-40 and 11-120 mg.gSS⁻¹ were reported for MBRs treating greywater and municipal wastewater respectively. Similarly, carbohydrate and protein concentrations in the SMP of 3 and 9 mg.L⁻¹ and 4-33 and 4.5-34 mg.L⁻¹ were reported for MBRs treating greywater and municipal wastewater respectively. CST was also found lower in the MBR treating greywater with 12.6 s in comparison to 16.5 and 47 s for the systems treating municipal wastewater. These results revealed that it is likely that less fouling occurs in the system treating greywater and confirmed the findings of the short and long term fouling investigations. The higher critical fluxes found for the MBR treating greywater suggest longer fouling stages 1 and 2 as described by Judd (2006) (Figure 5.14) and consequently higher critical times. The higher fouling rates generally obtained in the sub-critical operation of the MBR are simply due to the longer stages 1 and 2, that is more time for accumulation of particles on the membrane surface.

Table 5.12: Biomass characteristics influencing membrane fouling.

	Current study	Trussel <i>et al.</i> (2004)	Germain (2004)	Le Clech (2002)	Judd (2006)
MLSS (g.L ⁻¹)	8.8	8	6.1	15.2	-
EPS _c (mg.gSS ⁻¹)	4.4	16-33	30.9	13.4	6-40
EPS _p (mg.gSS ⁻¹)	21.6	70-102	113.7	42.8	11-120
SMP _c (mg.L ⁻¹)	3	10-31	4	-	4.5-33
SMP _p (mg.L ⁻¹)	9	16-32	28	-	4.5-34
SMP _{COD} (mg.L ⁻¹)	75	-	40	87*	-
SMP _{turbidity} (NTU)	14.7	-	-	-	-
CST (s)	12.6	-	16.5	47	-

*: TOC; #: not detectable.

In the case of the MCR the fouling mechanisms can also be described by such three-stage principle. Indeed, the shape of the curves obtained for the MCR in the short and

long term fouling experiments confirm a period of cake formation and pore blocking (stages 1 and 2) with relatively steady TMP followed by a TMP jump (stage 3). The main difference in this case will be the components producing this fouling as the EPS and SMP fractions does not exist in the MCR. It is probable that the fouling is generated by a combination of the colloids from the feed depositing on the membrane and interactions of the TiO₂ coated with the pollutants and the membrane surface. However, the high critical flux in combination with the very low critical suggest very quick stages 1 and 2, with rapid cake layer build up and pore blocking.

Chapter 6 **Products influence on treatment process**

6.1 **Influence of products on the properties of titanium dioxide to foul membranes**

6.1.1 Introduction

In the previous chapter, rapid and significant membrane fouling was observed in the MCR when run at a flux of $15 \text{ L.m}^{-2}.\text{h}^{-1}$ for the treatment of high strength greywater. However, similar tests in batch operation showed very little membrane fouling for fluxes up to $55 \text{ L.m}^{-2}.\text{h}^{-1}$ (Chapter 4.3). Such big differences in operation are surprising. However, the results obtained during the batch operation tests can be explained by the fact that the greywater was rapidly treated and consequently for the higher fluxes the TiO_2 was dispersed in fairly clean water and very little or no fouling was observed. Such observations suggest that the fouling propensity of TiO_2 changes significantly in the presence of greywater. To verify this, a test with tap water and TiO_2 was carried out and no membrane fouling for fluxes up to $105 \text{ L.m}^{-2}.\text{h}^{-1}$ was observed. Indeed, the fouling rates were found to be below $0.7 \text{ mbar.min}^{-1}$ for fluxes up to $105 \text{ L.m}^{-2}.\text{h}^{-1}$. This confirmed a change in the properties of TiO_2 when coated with pollutants that increased its fouling propensity. This section investigates the fouling properties of TiO_2 coated with different products present within greywater.

6.1.2 Bench-scale membrane fouling experiments

6.1.2.1 Influence of the products

A range of products including shower gel, shampoo, bathroom cleaner, conditioner, hand soap and bubble bath were diluted in tap water at concentration of 3 g.L^{-1} and placed in the reactor with 5 g.L^{-1} of TiO_2 . The concentration of 3 g.L^{-1} was chosen because it represents the upper range for organic concentration reported in the literature (Appendix I). Indeed, concentrations of products of 3 g.L^{-1} corresponded to solutions with COD concentrations between 692 and 810 mg.L^{-1} . Flux-step tests were then carried out and the fouling rates determined (Figure 6.1). These types of products were chosen because they represent the range of products that can actually be found in

greywater collected from bathrooms such as the one used in the investigation of the pilot plants. However, for economic and time reasons only one product of each type was initially picked.

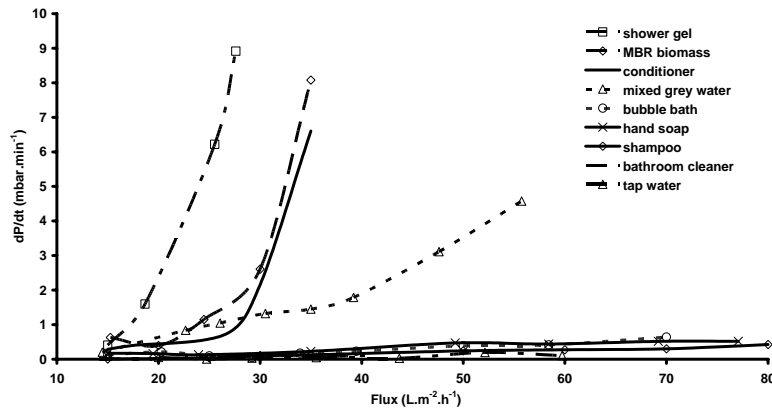

Figure 6.1: Fouling rates graph for different products.

The bathroom cleaner, the shampoo, the hand soap and the bubble bath did not significantly foul the membrane as shown by the fouling rate being below $0.7 \text{ mbar}\cdot\text{min}^{-1}$ for fluxes up to $80 \text{ L}\cdot\text{m}^{-2}\cdot\text{h}^{-1}$, the maximum tested (Figure 6.1). This was similar to fouling rates observed in MBRs. For example, Alvarez-Vazquez (2005) and Ndinisa *et al.* (2004) reported fouling rates in sub-critical conditions between 0.1 and $0.49 \text{ mbar}\cdot\text{min}^{-1}$ at fluxes below $40 \text{ L}\cdot\text{m}^{-2}\cdot\text{h}^{-1}$. For similar fluxes, in this study the fouling rates were generally below $0.47 \text{ mbar}\cdot\text{min}^{-1}$. The fouling rate curves obtained for these products were slightly higher than the one obtained for tap water which had for the higher fluxes a maximum fouling rate of $0.2 \text{ mbar}\cdot\text{min}^{-1}$. In contrast, rapid fouling was observed with the conditioner solution for fluxes above $25 \text{ L}\cdot\text{m}^{-2}\cdot\text{h}^{-1}$. To illustrate, the fouling rate was $6.6 \text{ mbar}\cdot\text{min}^{-1}$ at a flux of $35 \text{ L}\cdot\text{m}^{-2}\cdot\text{h}^{-1}$ (Figure 6.1). Fouling occurred even more quickly with the shower gel solution as demonstrated by the fact that the fouling rates increased sharply from a flux of $15 \text{ L}\cdot\text{m}^{-2}\cdot\text{h}^{-1}$, reaching $9.8 \text{ mbar}\cdot\text{min}^{-1}$ at a flux of $30 \text{ L}\cdot\text{m}^{-2}\cdot\text{h}^{-1}$. These results showed that not all the products that could potentially be found in a mixed greywater would alter the fouling propensity of TiO_2 . The results obtained with the mixed greywater from the Fedden house site confirmed this as the fouling rates observed were between the two extremes found for the individual products. Indeed, fairly low fouling rates below $1.5 \text{ mbar}\cdot\text{min}^{-1}$ were found for fluxes below $35 \text{ L}\cdot\text{m}^{-2}\cdot\text{h}^{-1}$. For fluxes above this value, a moderate increase of the fouling rates can be seen. For example, the fouling rates

increased from 1.8 to 4.6 mbar.min⁻¹ when the flux increased from 40 to 55 L.m⁻².h⁻¹. Interestingly, the fouling rate curve obtained for the biomass (MLSS~8.4 g.L⁻¹) was very similar to the one obtained with the conditioner. Indeed, for fluxes above 25 L.m⁻².h⁻¹, higher fouling rates were observed with the biomass than with TiO₂ with the mixed greywater. This is in opposition to what was found in the fouling study of the tubular membranes in the pilots (Chapter 5.3). However, the critical flux of 22 L.m⁻².h⁻¹ found in this case was in the range of typical values reported in the literature. Indeed, Pollice *et al.* (2005) reported a critical flux of 20 L.m⁻².h⁻¹ in a submerged MBR with flat plate membranes. Similarly, Ndinisa *et al.* (2006) reported critical fluxes between 16 and 42 L.m⁻².h⁻¹ for different conditions of aeration in a submerged MBR also with a flat sheet membrane.

This first set of experiments showed that two products, the shower gel and the conditioner, when in solution with TiO₂ significantly increased the membranes fouling rate. The observed results were not shown to hold when alternative brands of shower gel were tested (Figure 6.2). Interestingly, most of the shower gels tested did not initiate fouling and only the Lynx shower gel, was found, when coated on TiO₂, to foul the membrane. To illustrate, in the case of the shower gel Lynx a fouling rate of 5.8 mbar.min⁻¹ was recorded at a flux of 30 L.m⁻².h⁻¹. In contrast, the fouling rates of the other shower gels were included between 0.1 and 0.4 mbar.min⁻¹ at the flux of 30 L.m⁻².h⁻¹ and generally below 0.8 mbar.min⁻¹ for fluxes up to 70 L.m⁻².h⁻¹. This suggests that only specific ingredients will generate such a result and not a type of product.

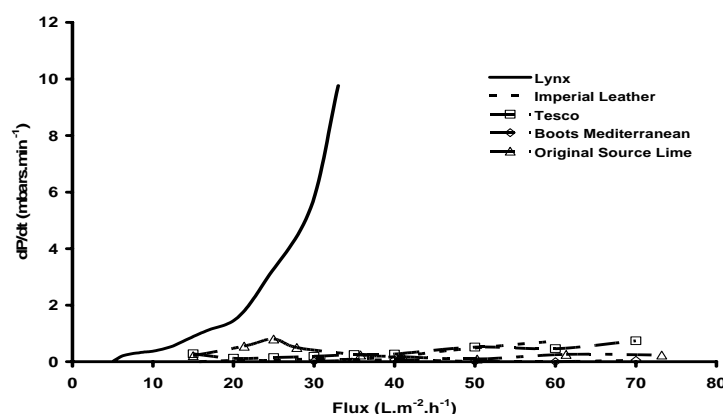

Figure 6.2: Fouling rates graph for different shower gels.

6.1.2.2 Influence of the concentration

The influence of the concentration of the products on the fouling was investigated with the two products that initiated the most important fouling; the Lynx shower gel and the Pantene ProV conditioner, and another product, the bubble bath Imperial Leather (Figure 6.3).

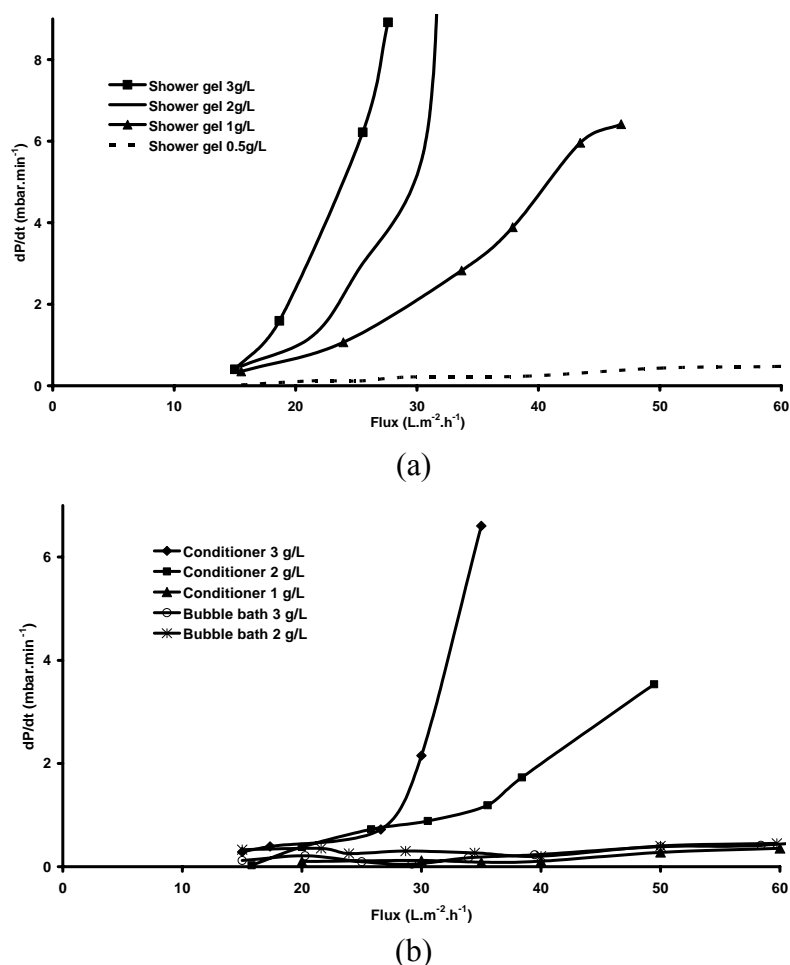

Figure 6.3: Influence of the concentration on the fouling rates with (a) shower gel and (b) conditioner and bubble bath.

The results were similar for the shower gel and the conditioner. Indeed, the fouling rates decreased with the concentration of the product. To illustrate, in the case of the conditioner at a flux of $35 \text{ L}\cdot\text{m}^{-2}\cdot\text{h}^{-1}$ fouling rates of 6.6, 1.2 and $0.1 \text{ mbar}\cdot\text{min}^{-1}$ were observed for concentrations of 3, 2 and $1 \text{ g}\cdot\text{L}^{-1}$ respectively (Figure 6.3). Alternatively, in the case of the bubble bath the diminution of the concentration did not have an influence on the already low fouling rates. For instance, a fouling rate of $0.4 \text{ mbar}\cdot\text{min}^{-1}$ was found for both concentrations of 2 and $3 \text{ g}\cdot\text{L}^{-1}$ at a flux of $50 \text{ L}\cdot\text{m}^{-2}\cdot\text{h}^{-1}$.

$^2.h^{-1}$ (Figure 6.3). It should be noted that at concentrations of 1 and 0.5 $g.L^{-1}$ of conditioner and shower gel respectively, very little fouling was observed and the fouling rates stayed below 1 mbar.min^{-1} for fluxes up to $70 \text{ L.m}^{-2}.h^{-1}$. These results confirmed that the fouling observed is dependant on the interaction between the product and the TiO_2 and the proportion of product adsorbed on the surface of the TiO_2 .

6.1.2.3 Particle size and surface analysis

During the previous tests with the Lynx shower gel, formation of flocs was usually observed. Complementary analyses of the floc size distribution were then carried out (Figure 6.4). For this, it was not possible to measure the particle size with the TiO_2 concentration of 5 g.L^{-1} as the detection cell saturated because of too many particles. Consequently, the TiO_2 concentration had to be decreased to 1 g.L^{-1} . To keep the same proportion of pollutant and TiO_2 during the measurement, the pollutant concentration was also reduced proportionally to keep the same mass ratio TiO_2 /product.

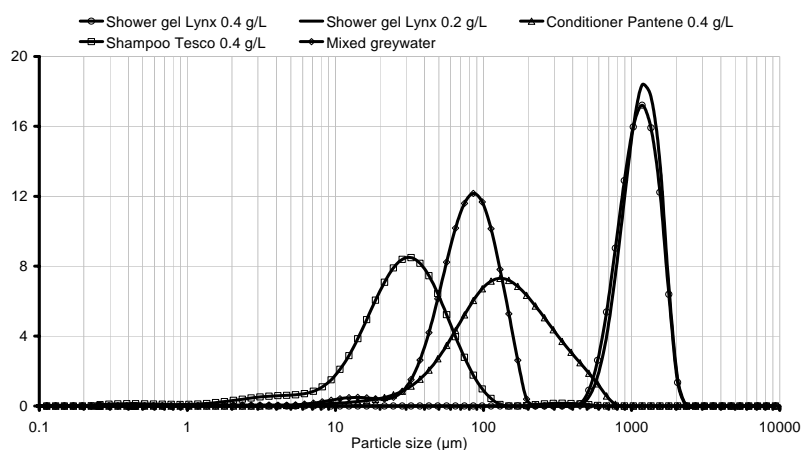

Figure 6.4: Particle size distribution of the TiO_2 flocs in different solutions.

The results revealed that in fact flocs of different sizes were generated when the TiO_2 was dispersed in a solution containing pollutants (Table 6.1). Indeed, as expected the bigger flocs were found with the Lynx shower gel with a median size of $1102 \mu\text{m}$. It should be noted that a decrease of the concentration of the shower gel did not generate a change in size of the flocs as similar median floc sizes of 1102 and $1137 \mu\text{m}$ were recorded for shower gel concentrations of 0.4 and 0.2 g.L^{-1} respectively. Interestingly,

the particle sizes in the other solutions were all bigger than the one obtained with tap water suggesting that when coated with pollutants TiO_2 tend to agglomerate. Indeed, the median size of the particle in tap water was 15 μm whereas it was 130, 29 and 74 μm in the solutions of conditioner and shampoo and mixed greywater respectively.

Table 6.1: Particle size analysis.

Product	TiO_2 / Product (g.L^{-1})	d_{50} (μm)
Shower gel Lynx	1 / 0.4	1102
Shower gel Lynx	1 / 0.2	1137
Conditioner Pantene	1 / 0.4	130
Shampoo Tesco	1 / 0.4	29
Mixed greywater	1 / diluted 5 times	74
Tap water	1 / -	15

Moreover, it was found that the bigger flocs appeared for the slurries generating the higher fouling rates (Figure 6.5). This is in opposition to what was usually reported in the literature. For example, Park *et al.* (2006) reported higher fouling index with smaller silica particles (20 and 3 μm) during filtration in a dead-end micro-filtration system. Similarly, Cho *et al.* (2006) observed an increase of the fouling with smaller flocs during the filtration of flocs ranging from 90 to 447 μm generated by coagulation of NOM with poly-aluminium chloride in a submerged micro-filtration system. For floc size of around 1 mm as it was found for the Lynx shower gel, settling of the flocs on the membrane surface can take place, leading to a rapid increase of the cake layer and consequently of the fouling rate. However, this phenomenon should be limited with a vertical membrane set up as it is the case in the pilot MCR.

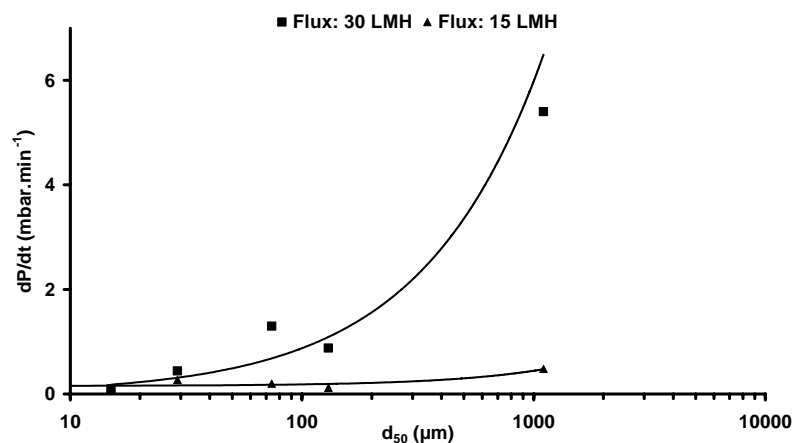

Figure 6.5: Fouling rate vs. floc size.

Pictures of the particles in tap water and in the shower gel solution are reported in Figure 6.6. A clear difference can be seen between the individual particles dispersed in the tap water (Figure 6.6a) and the agglomerate of particles observed in the solution of shower gel (Figure 6.6b). However, the analysis of the surface of the particles with a Scanning Electron Microscope (SEM) did not show any difference between clean TiO_2 and TiO_2 coated with shower gel Lynx (Figure 6.7).

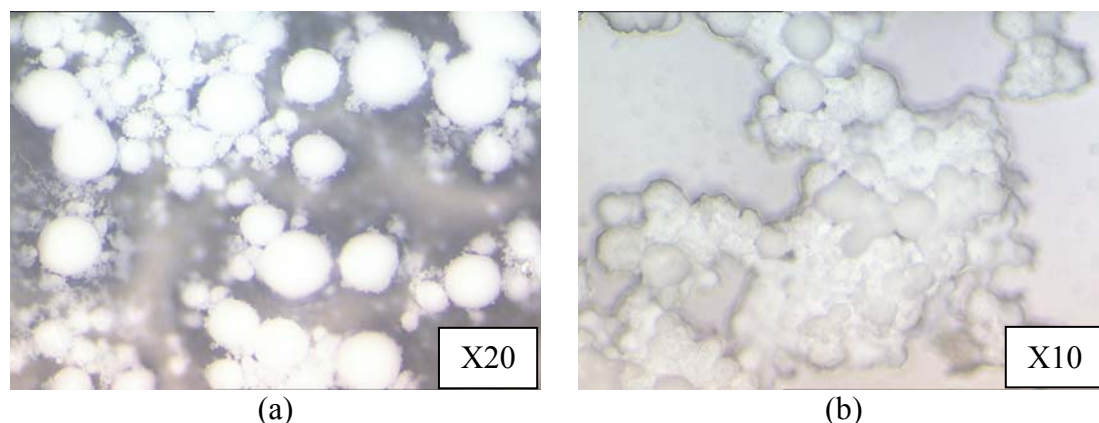

Figure 6.6: Microscope pictures of TiO_2 flocs (a) in tap water and (b) solution of shower gel Lynx.

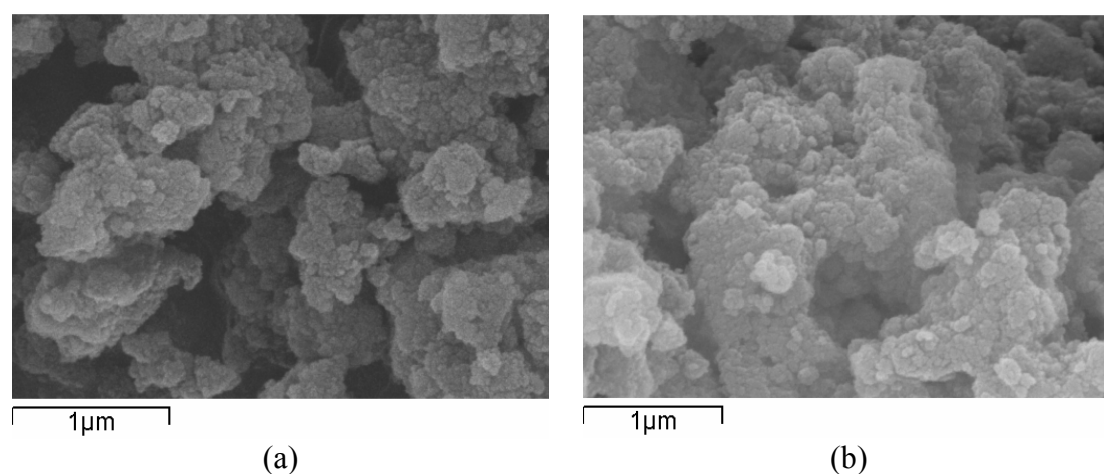

Figure 6.7: SEM pictures of (a) clean TiO_2 and (b) TiO_2 coated with shower gel Lynx.

The results obtained in this study suggest that a reaction occurs between the products and TiO_2 and generates a change in the properties of the slurry which then become more foulent. A study of the ingredients of the Lynx shower gel, the product with which the higher fouling rates were obtained, showed that it contains the typical chemicals found in most products of this type such as sodium laureth sulfate, cocamidopropyl bataine or tetrasodium EDTA (Appendix III). Only one compounds

found in this shower gel, acrylates/palmeth-25 acrylate copolymer, was not commonly found in the other products tested in this study and could be thought of the chemical triggering the flocculation of the TiO_2 particles. Indeed, polymers have commonly been used for flocculation and acrylates/palmeth-25 acrylate copolymer is used as a thickener or viscosity increasing agent (NICNAS, 2004). However, another polymer, styrene/acrylates copolymer, was also found in the shower gels Original Source and Boots with which no significant fouling was observed. Too little information about these polymers was available in the literature to verify potential differences in their compositions leading to the differences observed in the fouling.

6.1.2.4 Influence of the operating parameters

- UV illumination

After illumination under UV lights for 16 hours, four solutions containing shower gel, shampoo, conditioner and mixed greywater mixed with TiO_2 respectively were tested (Figure 6.8).

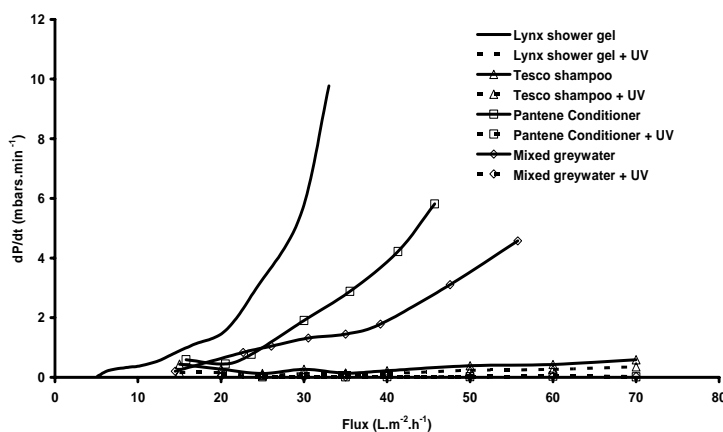

Figure 6.8: Fouling rates curves with and without UV illumination.

A similar trend was found for the four solutions. Indeed, very limited fouling was observed for fluxes up to $70 \text{ L.m}^{-2}.\text{h}^{-1}$. To illustrate, without UV illumination at a flux of $30 \text{ L.m}^{-2}.\text{h}^{-1}$, fouling rates of 5.8, 1.9, 1.3 and $0.27 \text{ mbar.min}^{-1}$ were observed for the shower gel, conditioner, mixed greywater and shampoo respectively. In contrast, the fouling rates of all these products were found to be between 0.01 and 0.13

$\text{mbar}\cdot\text{min}^{-1}$ at the same flux of $30 \text{ L}\cdot\text{m}^{-2}\cdot\text{h}^{-1}$ and generally below $0.36 \text{ mbar}\cdot\text{min}^{-1}$ for fluxes up to $70 \text{ L}\cdot\text{m}^{-2}\cdot\text{h}^{-1}$. These results suggest that after 16 hours under UV light all solutions were treated and as observed previously no fouling occurred with the TiO_2 dispersed in fairly clean water.

To understand the influence of the UV illumination time on the fouling, tests were then carried out with a slurry of shower gel and TiO_2 placed under UV lights for various times. It was found that the fouling rates decreased when the UV illumination time increased (Figure 6.9) which is consistent with the previous findings. To illustrate, at a flux of $50 \text{ L}\cdot\text{m}^{-2}\cdot\text{h}^{-1}$, fouling rates of 10.9, 4.7, 0.9 and $0.7 \text{ mbar}\cdot\text{min}^{-1}$ were found for illumination times of 30, 45, 90 and 120 minutes respectively. No significant fouling was observed for the solution that was under UV light for 2 hours. Indeed, a maximum fouling rate of $1.8 \text{ mbar}\cdot\text{min}^{-1}$ was observed at a flux of $80 \text{ L}\cdot\text{m}^{-2}\cdot\text{h}^{-1}$. This suggests that, in these conditions of treatment, 2 hours should be the minimum retention time required in the reactor to ensure a good treatment while limiting the fouling of the membrane. The retention time in the MCR during the pilot study (Chapter 5) was 3.8 hours. Consequently, with such retention time the greywater should have been treated and very little fouling should have been observed. On the contrary, important fouling of the membrane was monitored limiting the operation of the MCR. This suggests that the TiO_2 particles did not have a sufficient exposition to UV light and thus the mixing conditions in the MCR were not appropriate.

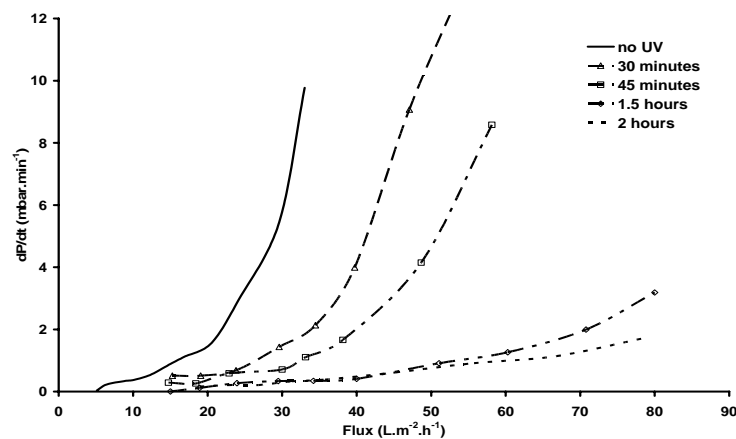

Figure 6.9: Fouling rates for different UV illumination times.

- Temperature

Temperature is an important parameter in this system as it should be relatively high due to the UV lights placed in the reactor. Indeed, in the pilot scale investigation (Chapter 5), the temperature in the MCR was found to fluctuate between 25 and 38 °C. Tests were then carried out with solutions of shower gel at different temperature. However, temperature influences membrane filtration due to its effect on the viscosity of fluids. It is then common to normalise the operating flux at a reference temperature, here 20 °C, using Equation 6.1 to compare the hydraulic performance of a system (Le Clech *et al.*, 2006).

$$J_T = J_{20} \times 1.025^{T-20} \quad \text{Equation 6.1}$$

The results reveal that the fouling rates decreased with the increasing temperature (Figure 6.10). To illustrate, at a flux of 30 L.m⁻².h⁻¹ fouling rates of 8.9, 2.4 and 0.3 mbar.min⁻¹ were found for temperature of 23, 38 and 50 °C respectively. This suggests that to limit the membrane fouling higher temperature in the system, around 50 °C, should be favoured. This is compatible with the conditions needed for the photocatalytic reaction as the optimum range of temperature was reported to be between 20 and 80 °C (Hermann, 1999).

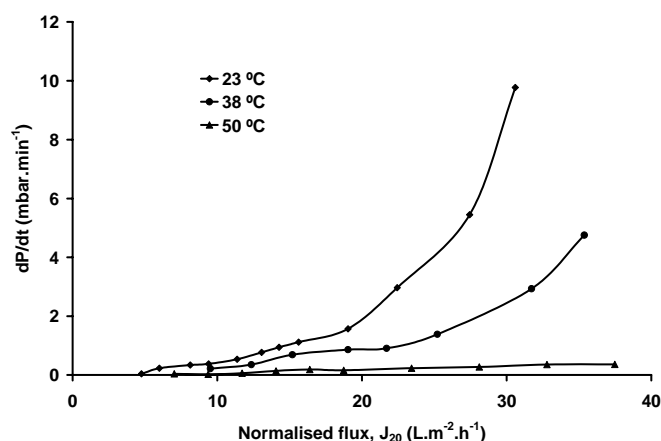

Figure 6.10: Fouling rates at different temperature.

No clear explanation could be found to describe this phenomenon. Nevertheless the temperature must have an influence of the on the properties of the pollutants (i.e. solubility etc.) and change the reaction usually occurring between the pollutants and

the TiO₂ particles. The temperature can also have an effect on the membrane itself. Indeed, Kowalska *et al.* (2006) observed a thermal expansion of the membrane material during filtration of the surfactant sodium dodecyl sulphate resulting in an increase of the flux (trials at constant pressure) and diminution of the retention.

6.2 Products spiking

Alongside the typical products constantly found in greywater such as shampoo, shower gel or hand soap, other products, essentially cleaning products, are discharged less often but in large quantities at once. This spiking is a potential issue for the treatment process performance, especially for the biological system when the products are toxic.

6.2.1 Products toxicity

6.2.1.1 *Microtox*

Microtox provided toxicity report for each product tested (Appendix IV) and the EC₅₀ was determined from the graphs of the effect on the luminescence against the concentration such as the ones reported in Figure 6.11.

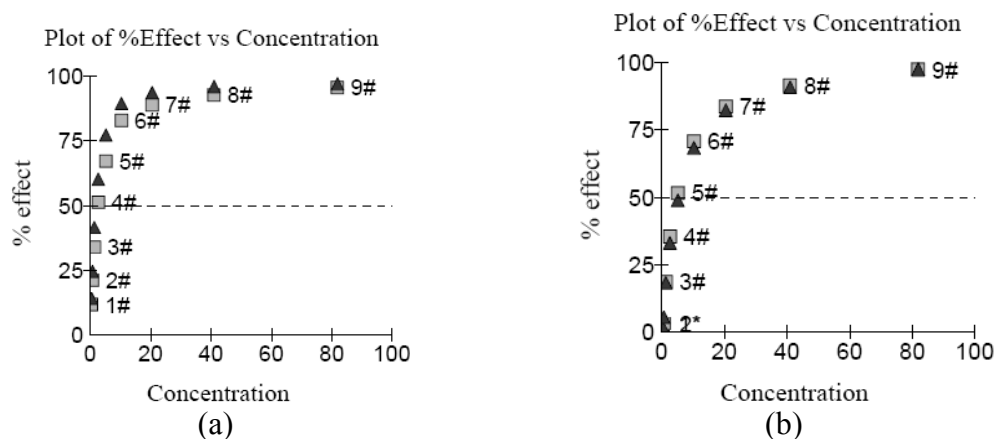

Figure 6.11: Typical graph obtained from the Microtox tests for (a) Original Source shower gel and (b) Morrisons all purpose cleaner.

All the products tested were found to be toxic to the bacteria *vibrio fischeri* as the EC₅₀ reported were generally below 100 $\mu\text{L.L}^{-1}$ (Table 6.2). The most toxic of the

products tested were the bleaches with EC_{50} as low as $2.4 \mu\text{L.L}^{-1}$. The EC_{50} could not be determined for the bleach Nest as all bacteria were killed from the lowest concentration tested (i.e. $<1 \mu\text{L.L}^{-1}$). The very high toxicity found for the bleaches was expected as disinfection is their main purpose. On the other hand, a similar trend was found for the washing up liquids, shampoos and shower gels with EC_{50} between 6.6 and $19.8 \mu\text{L.L}^{-1}$ except for one shampoo from the brand Morrisons which had an EC_{50} of $93.5 \mu\text{L.L}^{-1}$. Interestingly, the type of product tested in this study found with the lower toxicity was the all purpose cleaners with EC_{50} between 38.9 and $81.1 \mu\text{L.L}^{-1}$.

Table 6.2: Toxicity of different domestic products.

Product	Brand	$EC_{50} (\mu\text{L.L}^{-1})$	$EC_{50} (\text{mg.L}^{-1})$
Bleach	Morrisons bettabuy	2.5	2.7
	Nest	<1	<1
	Domestos	2.2	2.4
Washing-up liquid	Surcare	10.6	10.8
	Persil	12.3	13.2
	Morrisons	7.8	8.1
Washing powder	Ecover	-	8.1
	Cyclon	-	8.9
	Persil	-	29.3
All purpose cleaner	Ecover	58.9	58.1
	Morrisons	81.1	80.3
	Flash	38.9	38.9
Shampoo	Pantene	6.6	6.8
	VO5	11.7	12.4
	Morrisons	93.5	99.2
Shower gel	Original Source	11.9	12.3
	Johnson	13.2	13.1
	Morrisons	19.8	20.3

The general toxicity of such products was also reported by other authors. Indeed, Eriksson *et al.* (2006) investigated the toxicity of two mixed greywaters from groups of flats and other greywaters from individual appliances such as hand basin, shower, kitchen sink and washing machine on green algae *pseudokirchneriella subcapitata*. The EC_{50} reported varied between 101 and 950mL.L^{-1} with the lower values found for the shower and washing machine sources. The EC_{50} values reported for greywaters by Eriksson *et al.* (2006) were much higher than the ones obtained in this study for the individual products (Table 6.2). These results are coherent as the EC_{50} of greywater is expected to be higher than the ones of the individual products due to the

dilution in the water. Interestingly, the mixed sources were credited with fairly high EC_{50} (726-950 mL.L^{-1}) suggesting a low toxicity. Similarly, Petterson *et al.* (2000) studied the toxicity of 26 household detergents marketed in Sweden on *daphnia magna*. The corresponding EC_{50} were found to vary between 4 and 1615 mg.L^{-1} . However, 25 of the studied products had an EC_{50} below 100 mg.L^{-1} . This was very similar to the values found in the current study with Microtox as all products tested here had also an EC_{50} below 100 mg.L^{-1} . Petterson *et al.* (2000) reported the Ecover detergent, also studied in the present investigation, to be not toxic. However, in the test with Microtox carried out here, the toxicity of the Ecover detergent was found to be similar to the one of the other brands. Petterson *et al.* (2000) also observed that the most toxic products with EC_{50} below 10 mg.L^{-1} were also the ones with the higher concentrations of surfactants.

No significant difference could be observed between the different brands of each type of product suggesting similar compositions. Indeed, the ingredients list of the different products showed that similar chemicals were used (Appendix V). The toxicity of some of those chemicals found in the products tested was obtained from the toxicity database from the US Environmental Agency, Ecotox (USEPA, 2006).

Investigation of the different methods used to measure toxicity showed that the results depended greatly on the type of organisms on which the products were tested. To illustrate, for magnesium chloride, EC_{50} of 0.19, 0.28, 3.52 and 4.78 g.L^{-1} were reported for toxicity on water flea *daphnia magna*, cyclopoid copepod *cyclops abyssorum prealpinus*, fathead minnow *pimephales promelas* and western mosquitofish *gambusia affinis* respectively. Consequently, for comparison purpose it was decided to report the toxicity on water flea *daphnia magna* which is one of the organisms most commonly used. More chemicals were reported in the composition of shampoos and shower gels than in the other products and the toxicity was found to vary greatly from one chemical to another (Table 6.3). Indeed, chemicals such as sodium sulphate, sodium chloride and hexylene glycol with EC_{50} of 4.55, 3.68 and 3.2 g.L^{-1} were found to be moderately toxic. In contrast, chemicals such as lauryl sodium sulphate, ammonium sulphate and lactic acid with EC_{50} of 8-41, 20-430 and 73-1000 mg.L^{-1} were found to be more toxic. The toxicities found for the products were at the lower end of the range of toxicities found for the individual chemicals. Indeed, EC_{50} between 6.8 and 99.2 mg.L^{-1} were observed for the different shower gels and shampoos corresponding to the EC_{50} of the most toxic chemicals such as lauryl

sodium sulphate, sodium benzoate, ammonium sulphate or magnesium nitrate. Interestingly the EC_{50} measured for the different shampoos and shower gels were within the range reported for lauryl sodium sulphate one of their main component. Alternatively, the few chemicals found for the other products were found to be very toxic with EC_{50} generally below 100 mg.L^{-1} . In this case, the EC_{50} observed for the chemicals were in a similar range to the ones of the products in which they are. To illustrate, the main ingredient of bleach, sodium hypochlorite had an EC_{50} of 0.03-2.6 mg.L^{-1} in the Ecotox database and $<1-2.7 \text{ mg.L}^{-1}$ in this study. Similarly, formaldehyde, had an EC_{50} of 70 mg.L^{-1} in the Ecotox database which is in the range $<1-99.2 \text{ mg.L}^{-1}$ found for the different products that contained it.

Table 6.3: Toxicity of different chemicals contained in domestic products.

Chemical	Product	Ecotox (USEPA, 2006) EC_{50} (mg.L^{-1})	Present study EC_{50} (mg.L^{-1})
Lauryl sodium sulphate	Shower gel, shampoo	8-41	
Sodium sulphate	Shower gel, shampoo	4550	
Ammonium sulphate	Shower gel, shampoo	20-430	
Magnesium nitrate	Shower gel, shampoo	32-320	
Lactic acid	Shower gel, shampoo	73-1000	6.8-99.2
Sodium chloride	Shower gel, shampoo	3680	
Citric acid	Shower gel, shampoo	830-1530	
Sodium benzoate	Shower gel, shampoo	100	
Magnesium chloride	Shower gel, shampoo	190	
Hexylene glycol	Shampoo	3200	6.8-99.2
Formaldehyde	Washing-up liquid, all purpose cleaner	39-57	8.1-80.3
Limonene	Shower gel, shampoo, bleach, all pupose cleaner, washing-up liquid	70	$<1-99.2$
Sodium hypochlorite	Bleach	0.03-2.6	$<1-2.7$
Soap	Washing powder, all purpose cleaner, bleach	30*	$<1-80.3$

* for green algae *pseudokirchneriella subcapitata*.

Unidentified surfactants could also be found in the ingredient lists of those products. Indeed, domestic products such as detergents, shampoos and cosmetics have been reported to be mainly composed of synthetic surfactants such as linear alkylbenzene sulfonates (LAS) or alkylphenol ethoxylates (APEO) which are very resistant to biodegradation (Ikehata and Gamal El-Din, 2004). Palmquist and Hanæus (2005) measured concentrations of 10 nonylphenol ethoxylates (NPEO) in a mixed greywater ranging from 3 to 40 $\mu\text{g.L}^{-1}$. Similarly, Terzic *et al.* (2005) reported concentrations of LAS and NPEO of 2-10 and 0.1-0.5 mg.L^{-1} respectively, in municipal wastewater. Farre *et al.* (2001) assessed the toxicity of different surfactants with Microtox. Relatively high EC_{50} demonstrating a low toxicity were reported for polyethylene glycol (PEG) and NPEO with 379 and 95 mg.L^{-1} respectively. Alternatively, other surfactants such as alkyl alcohol polyethoxylates C10EO6 and C12EO2,3 and Nonylphenol were reported more toxic with EC_{50} of 4.9, 0.67 and 0.4 mg.L^{-1} respectively. Similarly, Gutierrez *et al.* (2002) investigated, also with Microtox, the toxicity of organic compounds found in wastewaters. Most of the products demonstrated a high toxicity. Indeed, EC_{50} were 0.82, 0.40 and 3.39 mg.L^{-1} for pentachlorophenol (PCP), 3,4-dichloroalinine (DCA) and 3,5-dichlorophenol (3,5-DCP) respectively. However, the surfactant LAS was found with a higher EC_{50} of 14.29 mg.L^{-1} . In addition, in their study Gutierrez *et al.* (2002) studied the toxicity of some heavy metals. Cu, Zn and Cd were found to be significantly toxic with EC_{50} of 0.19, 0.76 and 4.70 mg.L^{-1} respectively. These should also influence the overall toxicity of greywater as Eriksson *et al.* (2002) and Palmquist and Hanæus (2005) reported the presence of such heavy metals in mixed greywaters.

6.2.2 Influence of products spiking on the technologies

6.2.2.1 Biological

The influence of the dosing of the domestic products on the biomass of the MBR was investigated by respirometry. Figure 6.12 is an example of graph of the oxygen uptake vs. time obtained after such tests. It can be seen that with lower dose of products (in this case 0.5 mL.L^{-1}) the oxygen uptake is slightly lower than the one obtained for the control suggesting a limited toxicity of the product on the organisms. With other products than the one reported in Figure 6.12, higher oxygen uptake than the one of

the control were also observed for some of the doses revealing in this case a stimulation of the biological activity by the product dosed. Such behaviour was also reported in a very similar investigation conducted by Laine (2001). However, for all products dosed, at higher doses an inhibition effect due to the toxicity of the products occurred. Indeed, a clear reduction of the oxygen uptake can be observed for concentrations from 1 mL.L⁻¹ (Figure 6.12).

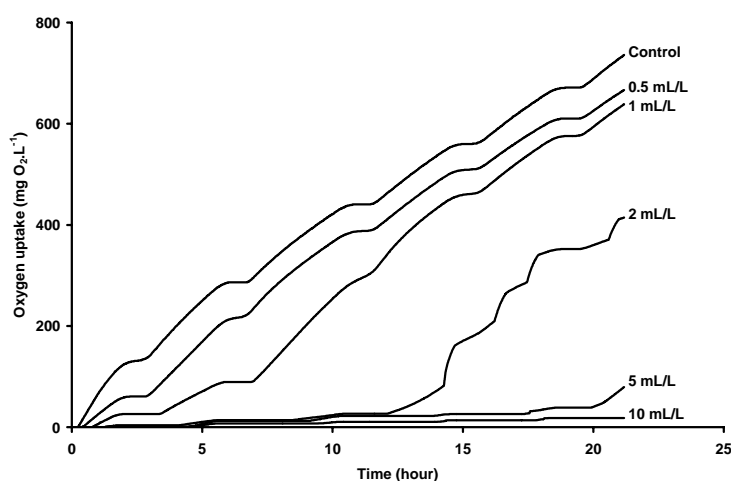

Figure 6.12: Oxygen uptake vs. time.

Interestingly, the effect observed was not permanent as a sharp increase of the oxygen uptake was observed after a certain duration which seemed to be dependant on the dose of product. In fact the period of the inhibition increased with the dose. To illustrate, in the case presented in Figure 6.12, the inhibition lasted 7, 12 and 20 hours for doses of 1, 2 and 5 mL.L⁻¹. It should be noted that in most cases the increase of the oxygen uptake rate after the inhibition period was higher than the one observed for the control suggesting a more important biological activity to recover from the shock caused by the products.

The results obtained showed that the three washing powders had a very similar effect on the bacteria (Figure 6.13a). As explained before the lower doses stimulated the biological activity resulting in SOUR above the one obtained for the control. However, the SOUR decreased when the doses increased and then reached a plateau for doses above 3 g.L⁻¹. The EC₅₀ determined from this graphs were very similar with 1.4, 1.6 and 1.7 g.L⁻¹ for the Cyclon, Persil and Ecover respectively (Table 6.4). It should be noted that it is advised on the package of the Cyclon to dissolve for hand washing one tablet in 10 L of water corresponding to a concentration of 3.5 g.L⁻¹

which is twice over the EC_{50} . Although laundry water should be diluted with the other fractions of greywater usually less polluted, the resulting concentration would still be fairly high and affect the biomass in the process.

The shape of the curves obtained for the bleaches were similar to one seen before; however, no dose stimulated the biological activity (Figure 6.13b). Indeed, the lowest dose of bleach added (0.5 mL.L^{-1}) affected the bacteria. The Domestos and Morrisons bleaches gave very similar results with EC_{50} of 0.5 and 0.8 mL.L^{-1} respectively (Table 6.4). Alternatively, the bleach Nest was found to be 'less toxic' with an EC_{50} of 3.1 mL.L^{-1} .

The Surcare and Persil washing-up liquids were found to have a similar effect on the organisms' respiration (Figure 6.13c) with EC_{50} of 37.2 and 24.1 mL.L^{-1} respectively (Table 6.4). Interestingly, the washing-up liquid from Morrisons was found to be very toxic with an EC_{50} below 3 mL.L^{-1} similar to what was found for the bleaches. An investigation of the chemical composition of the different products revealed that the Morrisons washing-up liquid contained a disinfectant explaining its high toxicity when compared to other washing-up liquids.

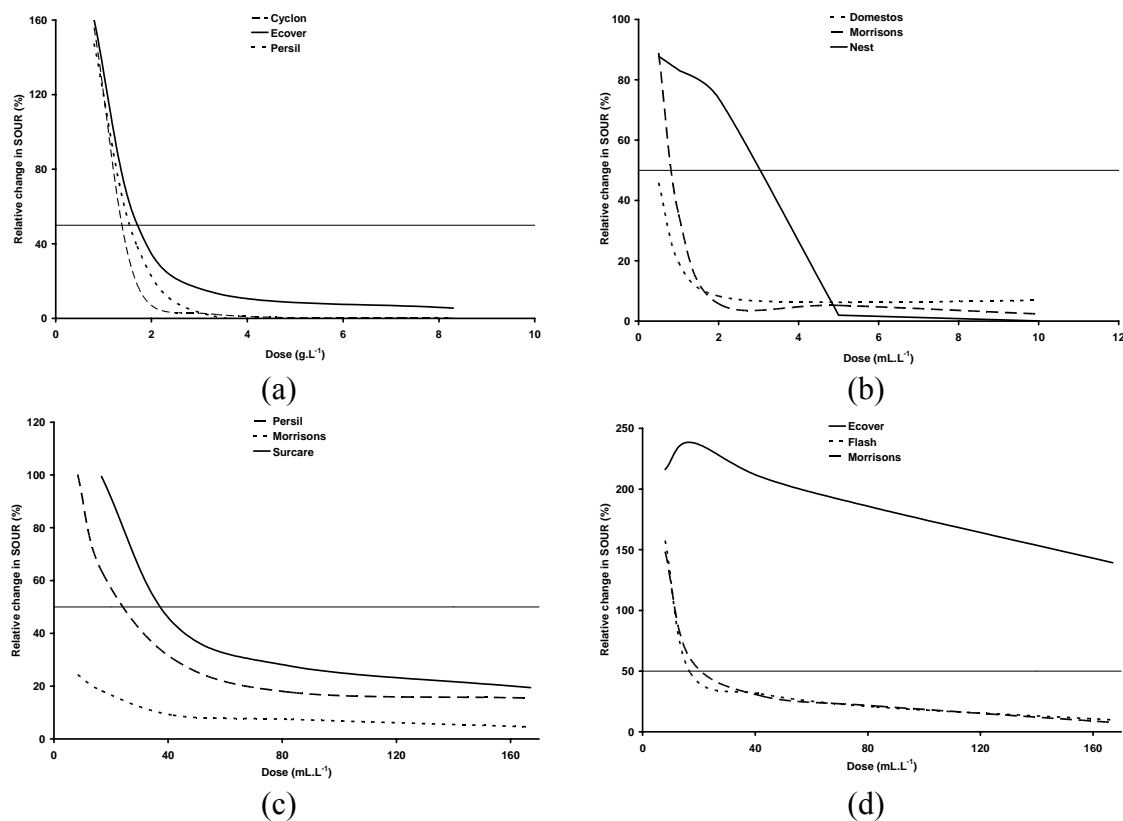

Figure 6.13: Relative change in SOUR vs. dose for (a) the washing powders, (b) the bleaches, (c) the washing-up liquids and (d) the all purpose cleaners.

Finally, two trends were observed with the all purpose cleaners (Figure 6.13d). The shape of the curves obtained for the first two products, Flash and Morrisons were similar to all the ones seen before with a rapid decrease of the SOUR for the lower doses and a plateau for the higher doses. The EC_{50} obtained were 20.2 and 16.5 mL.L⁻¹ for Morrisons and Flash respectively (Table 6.4). Alternatively, the Ecover product was found to be not toxic as for all the doses tested the SOUR determined were always above the one of the control. To illustrate, for a dose of 167 mL.L⁻¹ of Ecover products the SOUR was still 1.4 higher than the control. This result supports the case of this type of products considered as environmentally friendly.

Table 6.4: Toxicity of different products and chemicals obtained by respirometry.

Reference	Product	Organisms	Brand	EC_{50} (mL.L ⁻¹)	EC_{50} (g.L ⁻¹)
This study	Bleach	MBR biomass	Morrisons	0.8	0.84
			Nest	3.1	3.13
			Domestos	0.5*	0.49*
	Washing-up liquid		Surcare	37.2	37.77
			Persil	24.1	25.86
			Morrisons	<3*	<3.11*
	Washing powder		Ecover	-	1.70
			Cyclon	-	1.40
			Persil	-	1.60
	All purpose cleaner		Ecover	NM [#]	NM [#]
Morrisons		20.2	19.99		
Flash		16.5	16.60		
Laine (2001)	Bleach	MBR biomass	Tesco	2.5	-
	Caustic soda		N/A	7	-
	Vegetable oil		Tesco sunflower oil	23	-
	Perfume		Joe Bloggs Juice	20	-
	Washing liquid		Ariel	29	-
	Hair dye		L'Oreal	30	-
	Carpet cleaner		Vanish	41	-
	Bathroom cleaner		Tesco	60	-
	Alcohol		(Ethanol)	~300	-
	Gutierrez <i>et al.</i> (2002)		Cr	AS biomass	N/A
Zn		-	0.056		
Cd		-	0.034		
Cu		-	0.032		
LAS		-	NM [#]		
3,5-DCP		-	0.013		
Toluene		-	0.094		
PCP		-	0.108		
DCA	-	0.008			

* extrapolated value; [#] NM: EC_{50} not met for the doses tested.

Similarly, in their investigation of the toxicity of 26 household detergents marketed in Sweden on *daphnia magna*, Petterson *et al.* (2000) reported the Ecover detergent to be only one not toxic with an EC_{50} of 1615 mg.L^{-1} in opposition to $EC_{50} < 100 \text{ mg.L}^{-1}$ for the 24 others. Two similar works reported by Laine (2001) and Gutierrez *et al.* (2002) investigated the toxicity of products and chemicals on biomass from an MBR treating greywater and an activated sludge (AS) system treating municipal wastewater respectively (Table 6.4). The findings reported by Laine (2001) were generally very similar to the ones generated in the present study. To illustrate, Laine (2001) reported EC_{50} of 2.5 mL.L^{-1} for bleach and 29, 41 and 60 mL.L^{-1} for cleaning products such as washing liquid, carpet cleaner and bathroom cleaner respectively. Whereas, the EC_{50} from this study were $0.5\text{-}3.1 \text{ mL.L}^{-1}$ for bleaches and $16.5\text{-}37.2 \text{ mL.L}^{-1}$ for cleaning products such as washing-up liquids and all purpose cleaners. Other products tested by Laine (2001) such as hair dye, vegetable oil and perfume were also in the same range with EC_{50} of 30, 23 and 20 mL.L^{-1} respectively. Only alcohol (ethanol) seemed less toxic with an EC_{50} of about 300 mL.L^{-1} . The study reported by Gutierrez *et al.* (2002) focussed on organic compound and heavy metals commonly found in wastewater and that have been reported to be in greywater (Eriksson *et al.*, 2002; Palmquist and Hanæus, 2005). Gutierrez *et al.* (2002) observed EC_{50} between 8 and 108 mg.L^{-1} suggesting high toxicities for the chemicals tested individually in comparison to EC_{50} between 0.5 and 38 g.L^{-1} for the products investigated in this study. Alternatively, one of the chemical tested, the supposedly toxic surfactant LAS, was found to be not toxic as the EC_{50} was never met for the doses tested.

6.2.2.2 Chemical

The study reported in the previous section revealed that products found in greywater can affect the performance of biological processes due to their toxicity. The effect of these products on the performance of the catalytic process TiO_2/UV was then investigated by monitoring the changes in DOC removal observed with different dose of these products (Figure 6.14). It should be noted that the initial DOC concentration generally increased due to the doses of products added to the samples. The results are then presented in terms of a relative change of DOC removal in comparison to the control (sample without product added). In the case of the washing powders, the results obtained for Cyclon and Persil were surprising with the DOC removal varying

a lot from one dose to another without any particular trend. Consequently, it was very difficult to analyse these results and conclude on any influence of the dosing of these products. Alternatively, results obtained from the test with the Ecover followed a more expected trend (Figure 6.14a). Indeed, the DOC removal decreased when the dose increased. To illustrate, the relative change in DOC removal were 88, 43 and 22 % for doses of 0.2, 3.3 and 8.3 g.L⁻¹ respectively. An effect of 50 % on the DOC removal was observed for a dose of 2.5 g.L⁻¹.

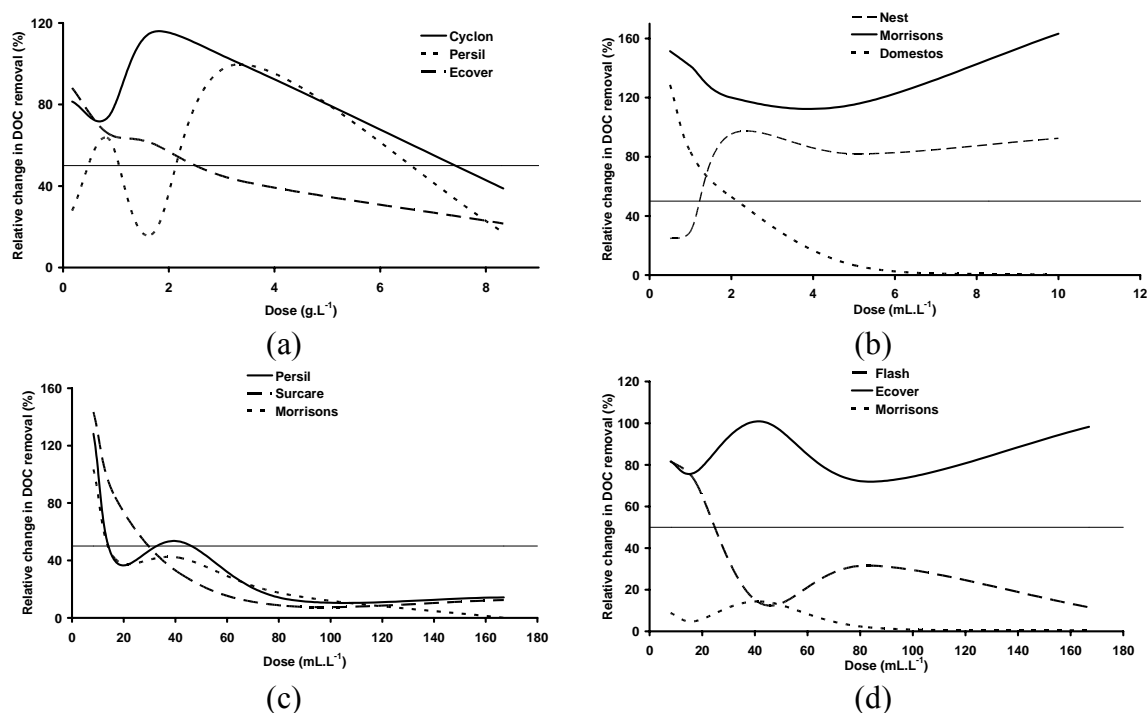

Figure 6.14: Relative change in DOC removal vs. dose for (a) the washing powders, (b) the bleaches, (c) the washing-up liquids and (d) the all purpose cleaners.

The results obtained for the bleaches were quite different from one brand to another. For the Morrisons bleach the DOC removal was found to always be above the removal of the control suggesting that the product had a beneficial effect on the reaction. However, the DOC removal decreased for the lower doses until it reached a minimal value for a dose of about 4 mL.L⁻¹ and then increased again for the higher doses. In the case of the Nest bleach, the removal was found to be very low, just under 30 % of the normal removal with doses below 2 mL.L⁻¹. Alternatively, it was stable between 80 and 90 % of the normal removal for doses above 2 mL.L⁻¹. For the Domestos, the DOC removal decreased when the dose increased and the 50 % decrease was reached for a dose of 2.2 mL.L⁻¹. The washing-up liquid was the only

type of product for which the three products tested had a similar trend. Indeed, the removal decreased when the dose increased until it reached a plateau for higher doses, doses above 80 mL.L^{-1} . The 50 % effect was recorded at doses of 14, 14 and 29 mL.L^{-1} for Persil, Morrisons and Surcare respectively. Finally, the results determined for the all purpose cleaners were different for the three products tested. Indeed, for the Ecover the relative change in DOC removal oscillated between 80 and 100 % for the range of dose tested suggesting a very limited influence of the product on the performance but independently from the dose. In contrast, the DOC removal for Morrisons detergent was always very low, below 15 % of the normal removal. This showed that the Morrisons all purpose cleaner had an important effect on the performance of the system. The last product, Flash, followed a more conventional trend with the removal decreasing when the dose increased. The DOC removal decreased of 50 % for a dose of 25 mL.L^{-1} .

6.2.3 Discussion

The results obtained for the spiking experiments showed that the products affected the performance of the chemical process even for low doses. Interestingly, the effects observed did not appear to be linked to the toxicity of the products. Although the influence of the dosed products in the chemical system did not seem to follow similar trends to the ones found for the biological system, it was found that the products tended to affect the performance of the chemical process for doses in the same range. For instance, a reduction of 50 % of the performance of the chemical and biological processes by Ecover washing powder was observed for doses of 1.7 and 2.5 g.L^{-1} respectively. The same reduction in performance by the washing-up liquids Persil, Morrisons and Surcare were found for doses of 14, 14 and 29 mL.L^{-1} respectively for the chemical process and 24.1, 3 and 37.2 mL.L^{-1} respectively for the biological system. Ultimately, the two technologies were found to be affected by spiking of domestic products.

The results observed for the toxicity tests with Microtox and the respirometry as well as values obtained for some of the chemical contained in the products from the Ecotox database are summarised in Table 6.5. It can be seen that the EC_{50} values obtained with Microtox and Ecotox are generally much smaller than with the respirometry method suggesting a lower toxicity for the latter. These results are essentially due to

the organisms used in each of the tests. The bacteria *vibrio fischeri* used in Microtox and water flea *daphnia magna* for the data from Ecotox are organisms which are not commonly in contact with the products tested in their natural environment. However, the bacteria used in the respirometry test were sampled from a stabilised MBR and they have then been in contact at some point with the products tested and consequently with the time only the most resistant survived. Microtox showed that all the domestic products tested here were very toxic to the organisms *vibrio fischeri* with EC_{50} generally below 100 mg.L^{-1} . A similar trend was observed for the individual chemicals from Ecotox. As mentioned above, the biomass of the MBR was found to be less sensitive to these products with EC_{50} still relatively low and generally below 40 g.L^{-1} . However, the results found for both techniques were not comparable for individual products. The most obvious example is the Ecover detergent as it had a similar toxicity as the other products of the range in the Microtox test but was found not toxic and on the contrary it stimulated the biological activity in the respirometry test. Gutierrez *et al.* (2002) in their study of the toxicity of chemicals with both Microtox and respirometry also found such differences between the two methods. To illustrate, the surfactant LAS was reported to be rather toxic with an EC_{50} of 14.29 mg.L^{-1} by the Microtox test. In contrast, it was found to have a beneficial effect on the activated sludge biomass activity in the respirometry test. Overall, the different domestic products included in greywater are themselves composed of a large range of organic and inorganic chemicals. Many of these compounds such as surfactants, softeners, preservatives and heavy metals have been reported to be toxic and poorly biodegradable (Table 6.4; Eriksson *et al.*, 2002). Because of the organisms used in the different tests, Microtox reports toxicity on the environment whereas respirometry delivers toxicity on the treatment system. This suggests that if a product is toxic to the biomass of the biological process it will affect the performance of the system but also it will not be removed from the water and then will be present in the treated effluent. It then becomes a direct risk to the environment especially if the treated water is used for outdoor application such as irrigation or car washing. Because the products tested seemed to be more toxic to organisms naturally present in the environment than the biomass of the biological process, even if it is partially removed from the water, it could still be a risk. There is then a necessity to minimize such products in greywater to ensure a limited discharge in the environment.

An option is to use the said ‘environmentally friendly’ products. However, the Ecover washing powder and all purpose cleaner investigated in this study were found with Microtox to be as toxic as the other products of the same type. To illustrate, EC_{50} of 8.1 and 8.9 $mg.L^{-1}$ were found for the washing powders Ecover and Cyclon respectively. Similarly, EC_{50} of 58.1 and 80.3 $mg.L^{-1}$ were observed for the washing powders Ecover and Cyclon respectively. This revealed that the eco-products were not less toxic than others. The results were different for the respirometry test. Indeed, the ecover products were found to be less toxic than other products. The EC_{50} was just slightly higher with 1.7 $g.L^{-1}$ for Ecover than for the other washing powders with 1.4 and 1.6 $mg.L^{-1}$ for Cyclon and Persil respectively. However, a major difference was observed between the Ecover all purpose cleaner and the other brands. Indeed, it had beneficial effect on the biomass respiration for all doses tested whereas the other products were found to be toxic with EC_{50} around 20 $mg.L^{-1}$. Such result suggests that the Ecover detergent can be treated by the biological system and consequently be completely removed from the greywater. This shows that by carefully choosing the products it is possible to limit the introduction of toxic chemicals in the greywater and avoid the alteration of the performance of the system and the discharge of toxic products.

Table 6.5: Comparison of the toxicity and the actual dose of products in greywater.

Product	Brand	EC_{50} ($mg.L^{-1}$)			Estimated concentration in greywater ($mg.L^{-1}$)
		Microtox	Respirometry	Ecotox	Single house
Bleach	Morrisons	2.7	841		
	Nest	<1	3131	0.03-30	137
	Domestos	2.4	489		
Washing-up liquid	Surcare	10.8	37777		
	Persil	13.2	25859	39-70	115
	Morrisons	8.1	<3110		
Washing powder	Ecover	8.1	1700		
	Cyclon	8.9	1400	30	528
	Persil	29.3	1600		
All purpose cleaner	Ecover	58.1	NM		
	Morrisons	80.3	19988	30-70	207
	Flash	38.9	16600		

Concentrations of the different type of products have been estimated for a 2-person house with an average greywater production of 98 $L.d^{-1}.person^{-1}$ (Table 6.5). The

concentration reported were calculated for one use of each of the products and considered diluted in the daily production. The concentrations reported then represent the amount that would be sent to the treatment system on the day the products were used. It should be noted that the different products are not used at the same frequency. In this case, the washing up liquid was used on a daily basis in opposition to the washing powder that was used 2 to 3 times a week and the all purpose cleaner 3 to 4 times a month. Moreover, two or more products can be used the same day and other products such as shampoo and shower gel will also be present. This implies that the concentrations reported are minimum values. The concentrations ranging from 115 to 528 mg.L⁻¹ are much higher than the EC₅₀ reported for the Microtox test suggesting that such doses would be very toxic to the environment. However, these concentrations are also much lower than the EC₅₀ reported for the respirometry test suggesting that in these conditions they should not affect too much the biological process. But as it is explained above these concentrations are for one product alone in the total volume and this will never be the case. Indeed, at any given time the greywater will be composed of a range of those products and consequently its toxicity should be higher than any of the products individually. This shows that a certain effect of the greywater on the biological system due to the use of those cleaning products should be expected. The bio-kinetics analysis (Chapter 5.2) revealed that the reaction rate was in fact limited by the toxicity of the substrate.

Chapter 7 **Conclusions**

- Traditional chemical processes remove significant portions of the organic materials within greywater. However, due to the existence of a recalcitrant fraction, coagulation and adsorption are not able to meet a broad spectrum of reuse standards. The observed limitation appears to be governed by the character of the raw greywater and suggest that such processes are never going to be suitable for very strict standards unless they are combined with another process that can achieve the remaining removal. However, activated carbon is able to treat all strengths of greywater to the most stringent standards. However, because of its limited capacity, activated carbon does not appear as a practical option as a primary process.
- Comparison of treatment pathways investigated suggests aerobic biological degradation to be the most suitable treatment of greywater. No other technology could match the overall performance or robustness of the MBR but were suitable in meeting the majority of reuse standards. In cases where the most stringent standards are adapted MBRs appear to be the only single process option. Advanced oxidation processes can meet similar levels of performance to MBRs but their sustainable operation is influenced by product components. As such future development is requires before commercially operational MCR unit could be adopted for reuse.
- In the MCR, the kinetic analysis revealed that the reaction was restricted due to mass transfer limitation during the adsorption phase. However, membrane fouling appeared to be the main limitation as it was not possible to operate it for long periods of time. It was found to be directly linked to interactions between the TiO₂ particles and some of the pollutants.
- The integration of membranes with biological reactors resulted in lower fouling propensities compared to membranes integrated with chemical processes. This was observed in terms of both short term critical flux and long

term critical time parameters. It appears this is due to the interactions of the chemicals within greywater and TiO₂ on the membrane surface.

- Whilst chemical spiking into biological processes demonstrates a toxic response at bench scale, the concentrations in real applications are unlikely to exceed the critical concentrations observed with exception of bleach. Potential problems can be reduced by selection of suitable products such as these marketed as environmentally friendly.

Chapter 8 **Future work**

The following work could be undertaken in order to further develop understanding of issues surrounding treatment of greywater for reuse with MBR and MCR:

- 1) The observed difference between the kinetics measured at batch and pilot scale required further investigation.
- 2) Interactions between specific products and TiO₂ particles were found to have a direct impact on the membrane fouling in the MCR. Further investigation is required to more completely understand the relationships that occur between individual products and TiO₂ and their influence on membrane fouling.
- 3) The effluent quality of the MCR was found to be good but inconsistent. Investigation of a broader range of operational conditions and system configurations would permit to assess the conditions needed to improve the robustness of the system. In particular, integration of point 1) and 2) would enable more focus design and ultimately lead to a more sustainable technology.
- 4) Spiking of domestic products was established to have a significant impact on the performance of the systems in batch experiments. Further experiments at pilot scale would reveal the actual impact of such products on the technologies in real conditions of operation. Moreover, investigations of unsteady conditions of operation would give additional indications on the potential of the technologies in a real situation. Specifically, the relationship between chemical spiking, colloid release and membrane fouling is critical for establishing robust operation.

Chapter 9 **References**

- Ahn, K.-H., Song, J.-H. and Cha, H.-Y. (1998) Application of tubular ceramic membranes for reuse of wastewater from buildings. *Water Science and Technology*, **38**(4-5), 373-382.
- Aiyuk, S., Amoako, J., Raskin, L., Van Haandel, A. and Verstraete, W. (2004) Removal of carbon and nutrients from domestic wastewater using a low investment, integrated treatment concept. *Water Research*, **38**(13), 3031-3042.
- Aksu, Z. (2005) Application of biosorption for removal of organic pollutants: a review. *Process Biochemistry*, **40**, 997-1026.
- Al-Jayyousi, O. R. (2003) Greywater reuse: towards sustainable water management. *Desalination*, **156**, 181-192.
- Almeida, M. C., Butler, D. and Friedler, E. (1999) At-source domestic wastewater quality. *Urban Water*, **1**, 49-55.
- Alvarez-Vazquez, H. (2005) Membrane bioreactors for sewage and stabilised leachate treatment. PhD Thesis, Cranfield University, UK.
- Andersen, M., Kristensen, G. H., Brynjolf, M. and Gruttner, H. (2001) Pilot-scale testing membrane bioreactor for wastewater in industrial laundry. *Water Science and Technology*, **46**(4-5), 67-76.
- Arika, M., Kobayashi, H. and Kihara, H. (1977) Pilot plant test of an activated sludge ultrafiltration combined process for domestic wastewater reclamation. *Desalination*, **23**, 77-86.
- Bansode, R. R., Losso, J. N., Marshall, W. E., Rao, R. M. and Portier, R. J. (2004). Pecan shell based granular activated carbon for treatment of chemical oxygen demand (COD) in municipal wastewater. *Bioresource Technology*, **94**, 129-135.
- Besançon, A. (2006) Determination of kinetic parameters and nutrients removal of a submerged membrane sequencing batch reactor treating greywater for reuse. MSc Thesis, Cranfield University.
- Bino, M. J. (2004) Greywater reuse for sustainable water demand management. IN: *Proceedings of the International Water Demand Management Conference*, 30th May-3rd June, Amman, Jordan.
- Birks, R. (1998) Biological aerated filters and membranes for greywater treatment. MSc Thesis, Cranfield University.
- Borin, M., Cossu, R., Lavagnolo, M. C. and Gandini, M. (2004) Phytotreatment of greywater with yellow water addition from an aesthetic approach. IN: *Proceedings of the International Conference On-Site wastewater treatment and recycling*, 12th-14th February, Murdoch University, Western Australia.

- Boyer, T. H. and Singer, P. C. (2005) Bench-scale testing of a magnetic ion exchange resin for removal of disinfection by-product precursors. *Water Research*, **39**, 1265-1276.
- Brewer, D., Brown, R. and Stanfield, G. (2000) *Rainwater and greywater in buildings: project report and case studies*. Report 13285/1, BSRIA Ltd., Bracknell, UK.
- Brookes, A., Jefferson, B., Guglielmi, G. and Judd, S. J. (2006) Sustainable flux fouling in a membrane bioreactor: impact of flux and MLSS. *Separation Science and Technology*, **41**, 1279-1291.
- Brouwer, H., Klapwijk, A. and Keesman, J. (1998) Identification of activated sludge and wastewater characteristics using respirometric batch-experiments. *Water Research*, **32**(4), 1240-1254.
- Casanova, L. M., Gerba, C. P. and Karpiscak, M. (2001) Chemical and microbial characterization of household graywater. *Journal of Environmental Science and Health*, **36**(4), 395-401.
- Chen, P. H. and Jenq, C. H. (1998) Kinetics of photocatalytic oxidation of trace organic compounds over titanium dioxide. *Environment International*, **24**(8), 871-879.
- Cho, M.-H., Lee, C.-H. and Lee, S. (2006) Effect of flocculation conditions on membrane permeability in coagulation-microfiltration. *Desalination*, **191**(1-3), 386-396.
- Christova-Boal, D., Eden, R. E. and McFarlane, S. (1996) An investigation into greywater reuse for urban residential properties. *Desalination*, **106**(1-3), 391-397.
- CMHC (Canada Mortgage and Housing Corporation) (2002) *Final assessment of conservation Co-op's greywater system*. Technocal series 02-100, CHMC, Ottawa, Canada.
- CMHC (Canada Mortgage and Housing Corporation) (2004) *Water reuse standards and verification protocol*. Research Report, CHMC, Ottawa, Canada.
- Cooney, D. O. (1999) *Adsorption design for wastewater treatment*. CRC press LLC. Boca Raton, USA.
- Coté, P., Buisson, H., Pound, C. and Arakaki, G. (1997) Immersed membrane activated sludge for the reuse of municipal wastewater. *Desalination*, **113**(2-3), 189-196.
- Crittenden, B. and Thomas, W. J. (1998) *Adsorption technology and design*. Typeset at The Spartan Press Ltd, Lymington, Hants, UK.
- Crook, J. and Surampalli, R. Y. (1996) Water reclamation and reuse criteria in the U.S. *Water Science and Technology*, **33**(10-11), 451-462.

- Dabrowski, A. (2001) Adsorption - from theory to practice. *Advances in Colloids and Interface Science*, **93**, 135-224.
- Dallas, S. and Ho, G. (2004) Subsurface flow reedbeds using alternative media for the treatment of domestic greywater in Monteverde, Costa Rica, Central America. *Water Science and Technology*, **51**(10), 119-128.
- Dallas, S., Scheffe, B. and Ho, G. (2004) Reedbeds for greywater treatment – case study in Santa Elena-Monteverde, Costa Rica, Central America. *Ecological Engineering*, **23**, 55-61.
- Dallmer, L. (2002) SQIRTS – An on-site stormwater treatment and reuse approach to sustainable water management in Sydney. *Water Science and Technology*, **46**(6-7), 151-158.
- Diaper, C., Dixon, A., Butler, D., Fewkes, A., Parsons, S. A., Strathern, M. and Stephenson T. (2001) Small scale water recycling systems – risk assessment and modelling. *Water Science and Technology*, **43**(10), 83-90.
- Dixon, A. M., Butler, D., Fewkes, A. and Robinson, M. (1999a) Measurement and modelling of quality changes in stored untreated greywater. *Urban Water*, **1**(4), 293-306.
- Edzwald, J. K. and Tobiasson, J. E. (1999) Enhanced coagulation: US requirements and a broader view. *Water Science and Technology*, **40**(9), 63-70.
- Edzwald, J. K., 1993. Coagulation in drinking water treatment: Particles, organics and coagulants. *Water Science and Technology*, **27**(11), 21-35.
- El-Khateeb, M. A. and El-Gohary, F. A. (2003) Combining UASB technology and constructed wetland for domestic wastewater reclamation and reuse. *Water Science and Technology: water Supply*, **3**(4), 201-208.
- El Samrani, A. G., Lartiges, B. S., Montarges-Pelletier, E., Kazpard, V., Barres, O. and Ghanbaja, J. (2004) Clarification of municipal sewage with ferric chloride: the nature of coagulant species. *Water Research*, **38**, 756-768.
- Elmitwalli, T. A., van Leeuwen, M., Kujawa-Roeleveld, K., Sanders, W. and Zeeman, G. (2006) Anaerobic biodegradability and digestion in accumulation systems for concentrated black water and kitchen wastes. *Water Science and Technology*, **53**(8), 167-175.
- Environment Agency UK (2006) Leaflet on Conserving Water in Buildings: 3-Greywater. Accessed in 2006 at www.environment-agency.gov.uk/commondata/105385/greywater_880769.pdf.
- Eriksson, E., Auffarth, K., Eilersen, A.-M., Henze, M. and Ledin A. (2003) Household chemicals and personal care products as sources for xenobiotic organic compounds in greywater. *Water SA*, **29**(2), 135-146.
- Eriksson, E., Auffarth, K., Henze, M. and Ledin A. (2002) Characteristics of grey wastewater. *Urban Water*, **4**, 85-104.

- Eriksson, E., Baun, A., Henze, M. and Ledin, A. (2006) Phytotoxicity of grey wastewater evaluated by toxicity tests. *Urban Water Journal*, **3**(1), 13-20.
- Ernst, M., Sperlich, A., Zheng, X., Gan, Y., Hu, J., Zhao, X., Wang, J. and Jekel, M. (2005) An integrated wastewater treatment and reuse concept for the Olympic park 2008, Beijing. IN: *Proceedings of the IWA Specialty Conference on Wastewater Reclamation and Reuse for Sustainability*, 8th-11th November, Jeju, Korea.
- Farre, M., Garcia, M.-J., Tirapu, L., Ginebreda, A. and Barcelo, D. (2001) Wastewater toxicity screening of non-ionic surfactants by Toxalert® and Microtox® bioluminescence inhibition assays. *Analytica Chimica Acta*, **427**(2), 181-189.
- Fearing, D. A., Banks, J., Guyetand, S., Monfort Eroles, C., Jefferson, B., Wilson, D., Hillis, P., Campbell, A. T., and Parsons, S. A. (2004) Combination of ferric and MIEEX for the treatment of humic rich water. *Water Research*, **38**, 2551-2558.
- Fittschen, I. and Niemczynowicz, J. (1997) Experiences with dry sanitation and greywater treatment in the ecovillage Toarp. *Water Science and Technology*, **35**(9), 161-170.
- Frazer-Williams, R., Avery, L., Jeffrey, P., Shirley-Smith, C., Liu, S. and Jefferson, B. (2005) Constructed wetlands for urban greywater recycling. IN: *Proceedings of the First conference on sustainable urban wastewater treatment and reuse*, 15th-16th September, Nicosia, Cyprus.
- Friedler, E. (2005) Performance of pilot scale greywater reuse RBC/MBR based systems. IN: *Proceedings of the Watersave, one day event on water demand management*, 14th June, London, UK.
- Friedler, E., Kovalio, R. and Galil, N. I. (2004) On-site greywater treatment and reuse in multi-storey buildings. IN: *Proceedings of the 1st International Conference on Onsite Wastewater Treatment & Recycling*, 11th-13th February, Fremantle, Western Australia.
- Gardner, T. and Millar, G. (2003) The performance of a greywater system at the healthy home in South East Queensland – three years of data. IN: *Proceedings of the Onsite '03 Conference*, 30th September-2nd October, Armidale, Australia.
- Gardner, T., Gibson, H. Carlin, G. and Vieritz, A. (2000). Water sensitive design to reduce the ecological footprint of urban development. IN: *Proceedings of the First Symposium of Water Recycling in Australia*, Adelaide 19th-20th October, CSIRO and Australian Water Association.
- Gerba, C. P., Straub, T. M., Rose, J. B., Karspiscak, M. M., Foster, K. E. and Brittain, R. G. (1995) Water quality study of greywater treatment systems. *Water Resources Journal*, **18**, 78-84.
- Germain, E. A. M. (2004) Biomass effects on membrane bioreactor operations. PhD Thesis, Cranfield University, UK.
- Goddard, M. (2006) Urban greywater reuse at the D'LUX development. *Desalination*, **188**, 135-140.

- Government of Western Australia (2005) Code of practice for the reuse of greywater in Western Australia.
- Gregory, J. D., Lugg, R. and Sanders, B. (1996) Revision of the national reclaimed water guidelines. *Desalination*, **106**, 263-268.
- Gross, A., Azulai, N., Oron, G., Ronen, Z., Arnold, M. and Nejidat, A. (2005) Environmental impact and health risks associated with greywater irrigation: a case study. *Water Science and Technology*, **52**(8), 161-169.
- Gross, A., Shmueli, O., Ronen, Z. and Raveh, E. (2006) Recycled vertical flow constructed wetland (RVFCW) – a novel method of recycling greywater for irrigation in small communities and households. *Chemosphere*, **In Press**.
- Gunther, F. (2000) Wastewater treatment by greywater separation: outline for a biologically based greywater purification plant in Sweden. *Ecological Engineering*, **15**, 139-146.
- Gutierrez, M., Etxebarria, J. and De las Fuentes, L. (2002) Evaluation of wastewater toxicity: Comparative study between Microtox® and activated sludge oxygen uptake inhibition. *Water Research*, **36**(4), 919-924.
- Hall, J. B., Batten, C. E. and Wilkins, J. R. (1974) *Domestic wash water reclamation for reuse as commode water supply using a filtration – reverse osmosis technique*. NASA Technical Note D-7600, USA.
- Henderson, R., Parsons, S. A. and Jefferson, B. (2006) Optimisation of Coagulation for Algae Treatment. IN Proc. *Water Quality Technology Conference and Exposition (WQTC)*, 5-9th November, Denver, USA.
- Hermann, J.-M. (1999) Heterogeneous photocatalysis: fundamentals and applications to the removal of various types of aqueous pollutants. *Catalysis Today*, **53**(1), 115-129.
- Hills, S., Birks, R., Diaper, C. and Jeffery, P. (2003) An evaluation of single-house greywater recycling systems. IN: *Proceedings of the IWA 4th International Symposium on Wastewater Reclamation & Reuse*, November 12-14th, Mexico City, Mexico.
- Hills, S., Smith, A., Hardy, P. and Birks, R. (2001) Water recycling at the millennium dome. *Water Science and Technology*, **43**(10), 287-294.
- Hlady, V., Lyklema, J. and Fleer, G. J. (1982). Effect of polydispersity on the adsorption of dextran on silver iodine. *Journal of Colloid and Interface Science*, **87**(2), 395-406.
- Hrudey and Raniga (1980) Greywater characteristics, health concerns and treatment technology. IN: *Proceedings of the post IAWPR conference seminar*, Toronto, Canada.
- Hu, J. Y., Ong, J. H., Shan, J. H., Kang J. B. and Ng, W. J. (2003) Treatability of organic fractions derived from secondary effluent by reverse osmosis membrane. *Water Research*, **37**, 4801-4809.

- Huang, X., Gui, P. and Qian, Y. (2001) Effect of sludge retention time on microbial behaviour in a submerged membrane bioreactor. *Process Biochemistry*, **36**, 1001-1006.
- Hurlimann, A. C. and McKay, J. M. (2006) What attributes of recycled water make it fit for residential purposes? The Mawson Lakes experience. *Desalination*, 187(1-3), 167-177.
- Hypes, W., Batten, C. E. and Wilkins, J. R. (1975) *Processing of combined domestic bath and laundry waste waters for reuse as commode flushing water*. Report NASA TN D-7937, Langley research centre, Hampton, USA.
- Ikehata, K. and Gamal El-Din, M. (2004) Degradation of recalcitrant surfactants in wastewater by ozonation and advanced oxidation processes: A review. *Ozone: Science and Technology*, **26**(4), 327-343.
- Imura, M., Sato, Y., Inamori, Y. and Sudo R. (1995) Development of a high efficiency household biofilm reactor. *Water Science and Technology*, **31**(9), 163-171.
- International Technology Service (2000) *Water reuse and recycling in Japan*. Report of Overseas Mission of Science and Technology Experts in Japan, 16th-20th October.
- Itayama, T., Kiji, M., Suetsugu, A., Tanaka, N., Saito, T., Iwami, N., Mizuochi, M. and Inamori, Y. (2004) On site experiments of the slanted soil treatment systems for domestic gray water. *Water Science and Technology*, **53**(9), 193-201.
- Jarusutthirak, C., Amy, G. and Croué, J.-P. (2002) Fouling characteristics of wastewater effluent organic matter (EfOM) isolates on NF and UF membranes. *Desalination*, **145**, 247-255.
- Jarvis, P., Jefferson, B. and Parsons, S. A. (2005) How the natural organic matter to coagulant ratio impacts on floc operational properties. *Environmental Science Technology*, **39**, 8919-8924.
- Jefferson, B., Laine, A., Diaper, C., Parsons, S., Stephenson, T. and Judd, S. J. (2000) Water recycling technologies in the UK. IN: *Proceedings of the Technologies for Urban Water Recycling Conference*, Cranfield University, 19th January.
- Jefferson, B., Le Clech, P., Smith, S., Laine, A. and Judd, S. (2000) The influence of membrane configurations on the efficacy of membrane bioreactors for domestic wastewater recycling. IN: *WEFTEC 2000 - Proceedings of the 73rd Annual Conference and Exposition On Water Quality and Wastewater Treatment*, 14-18th October, Anaheim, USA.
- Jefferson, B., Palmer, A., Jeffrey, P., Stuetz, R. and Judd, S. J. (2004) Greywater characterisation and its impact on the selection and operation of technologies for urban reuse. *Water Science and Technology*, **50** (2), 157-164.
- Jefferson, B., Palmer, A., Judd, S. and Jeffrey, P. (2002) Reliability of biological processes for urban reuse of grey and black water. IN: *Proceedings of the IWA Regional Symposium on Water Recycling in the Mediterranean Region*, 26th-29th September, Crete, Greece.

- Jeffrey, P. and Jefferson, B. (2003) Public receptivity regarding 'in-house' water recycling: results from a UK survey. *Water Science and Technology: Water Supply*, **3**(3), 109-116.
- Jenssen, P. D., Moehlum, T., Krogstad, T. and Vrale, L. (2005) High performance constructed wetlands for cold climates. *Journal of Environmental Science and Health*, **40**, 1343-1353.
- Jiang, J-Q., Graham, N. J. D. (1998) Pre-polymerised inorganic 355 coagulants and phosphorus removal by coagulation- A review. *Water SA*, **24**(3), 237-244.
- Judd, S. (1998) *Waste Water Reuse*. Report WW-09, Cranfield University, UK.
- Judd, S. (2006) *The MBR Book: Principles and applications of membrane bioreactors in water and wastewater treatment*. Elsevier Ltd, UK.
- Judd, S. and Till, S. W. (2000) Bacterial rejection in crossflow microfiltration of sewage. *Desalination*, **127**, 251-260.
- Kam S-K., Gregory, J. (2001) The interaction of humic substances with cationic polyelectrolytes. *Water Research*, **35**, 3557-3566.
- Karanfil, T., Kitis, M., Kilduff, J. E. and Wigton, A. (1999) Role of granular activated carbon surface chemistry on the adsorption of organic compounds. 2. Natural Organic Matter. *Environmental Science and Technology*, **33** (18), 3225-3223.
- Karanfil, T., Schlautman M. A. and Erdogan, I. (2002) Survey of DOC and UV measurement practices with implications for SUVA determination. *American Water Works Association Journal*, **94** (12), 68-80.
- Karpiscak, M. M., Foster, K. E. and Schmidt, N. (1990) Residential water conservation. *Water Research*, **26**, 939-948.
- Kilduff, J. E., Karanfil, T., Chin, Y.-P. and Weber, W. J. (1996). Adsorption of natural organic polyelectrolytes by activated carbon: A size exclusion chromatography study. *Environmental Science and Technology*, **30** (4), 1336-1343.
- Koopal, L. K. (1981). The effect of polymer polydispersity on the adsorption isotherm. *Journal of Colloid and Interface Science*, **83** (1), 116-129.
- Kowalska, I., Majewska-Nowak, K. and Kabasch-Korbutowicz, M. (2006) Influence of temperature on anionic surface active agent removal from water solution by ultrafiltration. *Desalination*, **198**, 124-131.
- Kujawa-Roeleveld, K. and Zeeman, G. (2006) Anaerobic treatment in decentralised and source-separation-based sanitation concepts. *Reviews in Environmental Science and Bio-Technology*, **5**, 115-139.
- Laak R. (1974) Relative pollution strengths of undiluted waste materials discharged in households and the dilution water used for each. In: *Manual of grey water treatment practice*, Winneberger, J. H. T. (ed). Ann Arbor Science Publishers Ltd, Ann Arbor, Michigan, USA

- Laine, A. T. (2001) Technologies for greywater recycling in buildings. PhD Thesis, Cranfield University, UK.
- Lazarova, V., Hills, S. and Birks, R. (2003) Using recycled water for non-potable, urban uses: a review with particular reference to toilet flushing. *Water Science and Technology: Water Supply*, **3**(4), 69-77.
- Le Clech, P., Chen, V. and Fane, T. A. G. (2006) Fouling in membrane bioreactors used in wastewater treatment. *Journal of Membrane Science*, **284**(1-2), 17-53.
- Le Clech, P., Jefferson, B., Chang, I. S. and Judd, S. J. (2003) Critical flux determination by flux-step method in a submerged membrane bioreactor. *Journal of Membrane Science*, **227**, 81-93.
- Lee, J. W., Chun, J. I., Jung, H. J. and Kwak D. H. (2005). Comparative studies on coagulation and adsorption as a pretreatment method for the performance improvement of submerged MF membrane for secondary domestic wastewater treatment. *Separation Science and Technology*, **40**, 2613-2632.
- Legrini, O., Oliveros, E. and Braun, A. M. (1993) Photochemical processes for Water Treatment. *Chemical Reviews*, **93**(2), 671-698.
- Lesjean, B. and Gnirss, R. (2006) Grey water treatment with a membrane bioreactor operated at low SRT and low HRT. *Desalination*, **199**, 432-434.
- Levenspiel, O. (1999) *Chemical reaction engineering*. John Wiley & Sons, Inc., 3rd edition. New York, USA.
- Li, Z., Guylas, H., Jahn, M., Gajurel, D. R. and Otteporhl, R. (2003) Greywater treatment by constructed wetlands in combination with TiO₂-based photocatalytic oxidation for suburban and rural areas without sewer system. *Water Science and Technology*, **48**(11-12), 101-106.
- Lin, C.-J., Lo, S.-L., Kuo, C.-Y. and Wu, C.-H. (2005) Pilot-scale electrocoagulation with bipolar aluminium electrodes for on-site domestic greywater reuse. *Journal of environmental engineering*, March, 491-495.
- Liu, R., Huang, H., Chen, L., Wen, X. and Qian, Y. (2005) Operational performance of a submerged membrane bioreactor for reclamation of bath wastewater. *Process Biochemistry*, **40**(1), 125-130.
- Lodge, B. (2003) Membrane fouling during domestic water recycling. EngD thesis, Cranfield University, UK.
- Lu, W. and Leung A. Y. T. (2003) A preliminary study on potential of developing shower/laundry wastewater reclamation and reuse system. *Chemosphere*, **52**, 1451-1459.
- Macomber, J., Cicek, N., Suidan, M. T., Davel, J., Ginestet, P. and Audic, J. M. (2005) Biological kinetic data evaluation of an activated sludge system coupled with an ultrafiltration membrane. *Journal of Environmental Engineering*, **131**(4), 579-586.

- Malcolm, R. L., and McCarthy, P. (1992) Quantitative evaluation of XAD-8 and XAD-4 resins used in tandem for removing organic solutes from water. *Environment International*, **18**, 597-607.
- March, J. G., Gual, M. and Orozco, F. (2004) Experiences on greywater re-use for toilet flushing in a hotel (Mallorca Island, Spain). *Desalination*, **164**, 241-247.
- Mars, R. (2004) Case studies of greywater recycling in Western Australia. IN: *Proceedings of the 1st International Conference on Onsite Wastewater Treatment & Recycling*, 11th-13th February, Fremantle, Western Australia.
- McQuire, S. (2006) *West Brunswick sustainable house water systems retrofit*. Final project report. Accessed in 2006 at www.greenmakeover.com.au.
- Metcalf and Eddy, Inc. (2003) *Wastewater Engineering – Treatment, Disposal and Reuse*. In: Tchobanoglous, G., Burton, F. L. and Stensel H. D. (eds). McGraw-Hill series in civil and environmental engineering, 4th edition. New York, USA.
- Mustow, S. and Grey, R. (1997) *Greywater and rainwater systems: recommended UK requirements*. Report 13034/2, BSRIA Ltd., Bracknell, UK.
- Ndinisa, N. V., Fane, A. G., Wiley, D. E. (2006) Fouling control in a submerged flat sheet membrane system: Part I – Bubbling and hydrodynamic effects. *Separation Science and Technology*, **41**(7), 1383-1409.
- New South Wales Government (2005) Domestic greywater treatment systems accreditation guidelines. New South Wales Department of Health.
- Ng, W. J. and Tan J. C. (1990) Some observations on organic removal in an SBR. *Biological wastes*, **33**, 169-179.
- Nghiem, L. D., Oschmann, N. and Schafer, A. I. (2006) Fouling in greywater recycling by direct ultrafiltration. *Desalination*, **187**, 283-290.
- NICNAS (National Industrial Chemicals Notification and Assessment Scheme) (2004) *Acrylates/Palmeth-25 Acrylate Co-polymer*. Report No PLC/398.
- Nolde, E. (1999) Greywater reuse systems for toilet flushing in multi-storey buildings - over ten years experience in Berlin. *Urban Water*, **1**(4), 275-284.
- Ognier, S., and Wisniewski, C. and Grasmick, A. (2004) Membrane bioreactor fouling in sub-critical filtration conditions: a local critical flux concept. *Journal of Membrane Science*, **229**, 171-177.
- Ottoson, J. and Stenstrom, T. A. (2003) Faecal contamination of greywater and associated microbial risks. *Water Research*, **37**, 645-655.
- Palmquist, H. and Hanæus, J. (2005) Hazardous substances in separately collected grey and blackwater from ordinary Swedish households. *Science of the Total Environment*, **348**, 151-163.

- Park, C., Kim, H., Hong, S. and Choi, S.-I. (2006) Variation and prediction of membrane fouling index under various feed water characteristics. *Journal of Membrane Science*, **284**, 248-254.
- Parsons S. A., Bedel, C. and Jefferson, B. (2000) Chemical vs. Biological Treatment of Domestic Greywater. In: *Proceedings of the 9th Intl. Gothenburg Symposium on Chemical Treatment*, 2-4th October 2000, Istanbul, Turkey.
- Parsons, S. A. (2004) *Advanced oxidation processes for water and wastewater treatment*. Gray Publishing, Tunbridge Wells, UK.
- Parsons, S. A. and Jefferson, B. (2006) *Introduction to Potable Water Treatment Processes*. Blackwell publishing, Oxford, UK.
- Petterson, A., Adamsson, M. and Dave, G. (2000) Toxicity and detoxification of Swedish detergents and softener products. *Chemosphere*, **41**, 1611-1620.
- Pollice, A., Brookes, A., Jefferson, B. and Judd, S. (2005) Sub-critical flux fouling in membrane bioreactors – A review of recent literature. *Desalination*, **174**(3), 221-230.
- Prathapar, S. A., Ahmed, M., Al Adawi, S. and Al Sidiari, S. (2006) Design, construction and evaluation of an ablation water treatment unit in Oman: a case study. *International Journal of Environmental Studies*, **63**(3), 283-292.
- Psoch, C. and Schiewer, S. (2005) Critical flux aspect of air sparging and backflushing on membrane bioreactors. *Desalination*, **175**, 61-71.
- Queensland Government (2003) Onsite sewerage facilities. *Guidelines for the use and disposal of greywater in unsewered areas*. Queensland Government, Local Government and Planning, Brisbane, Queensland Australia.
- Radcliffe, J. C. (2004) *Water recycling in Australia*. Report published by the Australian Academy of Technological Sciences and Engineering, Parkville, Australia.
- Ramon, G., Green, M., Semiat, R. and Dosoretz, C. (2004) Low strength greywater characterization and treatment by direct membrane filtration. *Desalination*, **170**, 241-250.
- Ratnaweera, H., Hiller, N., Bunse, U. (1999) Comparison of the coagulation behavior of different Norwegian aquatic NOM sources. *Environment International* **25**(2-3), 347-355
- Rose, J. B., Sun, G.-S., Gerba, C. P. and Sinclair, N. A. (1991) Microbial quality and persistence of enteric pathogens in greywater from various household sources. *Water Research*, **25**(1), 37-42.
- Rozich, A. F. and Gaudy, A. F. (1992) *Design operation of activated sludge processes using respirometry*. Lewis Publishers, Inc., Chelsea, Michigan, USA.
- Santala, E., Uotila, J., Zaitsev, G., Alasiurua, R., Tikka, R. and Tengvall J. (1998) Microbiological grey water treatment and recycling in an apartment building. In:

Proceedings of the 2nd International Advanced Wastewater Treatment, Recycling and Reuse, 14th-16th September, Milan, Italy.

Schonborn, A., Zust, B. and Underwood, E. (1997) Long term performance of the sand-plant-filter Schattweid (Switzerland). *Water Science and Technology*, **35**(5), 307-314.

Seo, G. T., Ahan, H. I., Kim, J. T., Lee, Y.J. and Kim, I. S. (2004) Domestic wastewater reclamation by submerged membrane bioreactor with high concentration powdered activated carbon for stream restoration. *Water Science and Technology*, **50**(2), 173-178.

Sharp E. L., Parsons, S. A. and Jefferson, B. (2004). The effects of changing NOM composition and characteristics on coagulation performance, optimisation and control. *Water Science and Technology: Water Supply*, **4** (4), 95-102.

Sharp E. L., Parsons, S. A. and Jefferson, B. (2005) Coagulation of NOM: Linking character to treatment. IN: *Proc. IWA Particle Separation Conference*, Seoul, Korea, June 1-3.

Sharp E. L., Parsons, S. A. and Jefferson, B. (2006) The impact of seasonal variations in DOC arising from a moorland peat catchment on coagulation with iron and aluminium salts. *Environmental Pollution*, **140**, 436-443.

Shin, H.-S., Lee, S.-M., Seo, I.-S., Kim, G.-O., Lim, K.-H. and Song, J.-S. (1998) Pilot-scale SBR and MF operation for the removal of organic and nitrogen compounds from greywater. *Water Science and Technology*, **39**(1), 128-137.

Shrestha, R. R., Haberl, R., Laber, J., Manandhar, R. and Mader, J. (2001) Application of constructed wetlands for wastewater treatment in Nepal. *Water Science and Technology*, **44**(11-12), 381-386.

Singer, P. C. and Bilyk, K. (2002) Enhanced coagulation using a magnetic ion exchange resin. *Water Research*, **36**, 4009-4022.

Smith, S., Judd, S., Stephenson, T. and Jefferson B. (2003) Membrane bioreactors – hybrid activated sludge or new process? IN: *Proceedings of IMSTEC03: the 5th International Membrane Science and Technology Conference*, Sydney, Australia.

Sostar-Turk, S., Petrinic, I. and Simonic, M. (2005) Laundry wastewater treatment using coagulation and membrane filtration. *Resources Conservation and Recycling*, **44**(2), 185-196.

Stephenson, T., Judd, S. J., Jefferson, B. and Brindle, K. (2000). Membrane bioreactors for wastewater treatment. IWA Publishing, London, UK.

Summers, R. S. and Roberts, P. V. (1988a). Activated carbon adsorption of humic substances: I. Heterodisperse mixtures and desorption. *Journal of Colloid and Interface Science*, **122** (2), 367-381.

- Summers, R. S. and Roberts, P. V. (1988a). Activated carbon adsorption of humic substances: II. Size exclusion and electrostatic interactions. *Journal of Colloid and Interface Science*, **122** (2), 382-397.
- Surendran, S. and Wheatley, A. D. (1998) Greywater reclamation for non-potable reuse. *Journal of Chartered Institution of Water and Environment Management*, **12**, 406-413.
- Tajima, A. (2005) The behaviour of the pathogenic microbes in the treated Wastewater reuse system and the establishment of the new technical standard for the reuse of treated wastewater. IN: *Proceedings of the IWA Specialty Conference on Wastewater Reclamation and Reuse for Sustainability*, 8th-11th November, Jeju, Korea.
- Terzic, S., Matosic, M., Ahel, M. and Mijatovic, I. (2005) Elimination of aromatic surfactants from municipal wastewaters: comparison of conventional activated sludge treatment and membrane biological reactor. *Water Science and Technology*, **51**(8), 447-453.
- Trussel, R. S., Merlo, R. P., Hermanowicz, S. W. and Jenkins, D. (2004) The effect of organic loading on membrane fouling in a submerged membrane bioreactor treating municipal wastewater. IN: *Proceedings of the Water Environment Federation Technical Exhibition and conference (WEFTEC)*, 2nd-6th October, New Orleans, USA.
- USEPA (U.S. Environment Protection Agency), (2006) Ecotox Database. Accessed in 2006 at www.epa.gov/ecotox.
- USEPA (U.S. Environmental Protection Agency) (2004) *Guidelines for Water Reuse*. Report EPA/625/R-04/108, USEPA, Washington, DC, USA.
- Vigneswaran, S. and Visvanathan, C. (1995) *Water treatment processes: simple options*. CRC Press, Boca Raton, Florida, USA.
- Ward, M. (2000) Treatment of domestic greywater using biological and membrane separation techniques. MPhil thesis, Cranfield University, UK.
- Wen, X., Bu, Q. and Huang, X. (2004) Study on fouling characteristic of an axial hollow fibres cross-flow microfiltration under different flux operations. IN: *Proceedings of the IWA speciality conference – Water Environment-Membrane Technology [WEMT 2004]*, 7th-10th June, Seoul, Korea.
- Winneberger, J. H. T. (1974) *Manual of grey water treatment practice*. In: Winneberger, J. H. T. (ed.). Ann Arbor Science Publishers Ltd, Ann Arbor, Michigan, USA

Appendix I: Greywater characteristics.

Appendix II: Technology library.

Appendix III: Constructed wetlands descriptions and performances.

Appendix IV: Shower gels compositions.

Appendix V: Examples of Microtox results.

Appendix VI: List of ingredients of products.

**Appendix I:
Greywater characteristics.**

Reference	Rose et al. (1991)	Shin et al. (1998)	Nolde (1999)	Nolde (1999)	Casanova et al. (2001)	Christova- Boal et al. (1996)	Laine (2001)	Brandes (1977) ^(a)	Olsson (1968) ^(a)
Type of water	Mixed	Mixed	Mixed	Mixed	Mixed	Mixed	Mixed	Mixed	Mixed
pH	6.54	7.00			7.47	6.4-8.1	7.47		
SS (mg/l)		185			35.09	48-120	100	162	141
Alkalinity (mg/l)	158	118				24-43			
Hardness (mg/l)	144								
Turbidity (NTU)	76.3				43.0	60-240	100.6		
BOD ₅ (mg/l)		5			64.85	76-200	146	149	196
BOD ₇ (mg/l)			50-100	150-250					
COD _{Cr} (mg/l)		79	100-200	250-430			451		
TOC (mg/l)							72.6	125	
Chloride (mg/l)	9.0				20.54	9.0-18			
T-N (mg/l)	1.7		5-10				8.73		
TKN (mg/l)		29.0				4.6-20		11.3	6.5
NH ₄ -N (mg/l)	0.74	9.0				<0.1-15		1.7	0.5
NO ₃ -N (mg/l)	0.98					<0.05-0.2		0.12	
T-P (mg/l)		1.7	0.2-0.6			0.11-1.8			
PO ₄ -P (mg/l)	9.3						0.4	1.4	7.8
Total Coliforms (CFU/100ml)	56-10 ⁵		10 ² -10 ³	10 ⁴ -10 ⁶	8.03*10 ⁷	500- 2.4*10 ⁷	7387	2.4*10 ⁷	3.8*10 ⁶
Faecal Coliforms (CFU/100ml)	25-6*10 ³		10 ⁻¹ -10 ¹	10 ⁴ -10 ⁶	5.63*10 ⁵	170- 3.3*10 ³		1.4*10 ⁶	9.4*10 ⁵
Faecal Streptococci (CFU/100ml)					2.38*10 ²	79-2.4*10 ³			
<i>E. Coli.</i> (CFU/100ml)							2022		

Reference	Bennett, Linstedt (1975) ^(a)	Gunther (2000)	Al- Jayyousi (2003)	Li et al. (2003)	Dallas et al. (2004)	Dallas and Ho (2004)	Shrestha et al. (2001)	Gardner and Miller (2003)	Brewer et al. (2000)
Type of water	Mixed	Mixed	Mixed	Mixed	Mixed	Mixed	Mixed	Mixed	Mixed
pH				6.9-8.1					
SS (mg/l)	183						97.9	48	
Alkalinity (mg/l)									
Hardness (mg/l)									
Turbidity (NTU)			69		96	103			212
BOD ₅ (mg/l)	260		121		167	254	200	97	
BOD ₇ (mg/l)		47							
COD _{Cr} (mg/l)			371	258-354			411		201
TOC (mg/l)				80.2-93.8					
Chloride (mg/l)									
T-N (mg/l)		3.72		9.7-16.6				6.6	
TKN (mg/l)	1.3								
NH ₄ -N (mg/l)	0		1				13.3		4
NO ₃ -N (mg/l)									
T-P (mg/l)		3.73	0.36	5.2-9.6		<1		0.7	
PO ₄ -P (mg/l)	10.2				16	9.6	3.1		
Total Coliforms (CFU/100ml)	1.5*10 ⁶							180000	7.3*10 ⁵
Faecal Coliforms (CFU/100ml)		94427			1.5*10 ⁸	7.7*10 ⁷		100	
Faecal Streptococci (CFU/100ml)		35848							
<i>E. Coli.</i> (CFU/100ml)				7.5*10 ³ - 2.6*10 ⁵					877

Reference	Gross et al. (2005)	Pidou et al. (2006)	Prathapar et al. (2005)	Prathapar et al. (2005)	Gross et al. (2006)	Siegrist et al. (1976) ^(a)	Pancuska et al. (1975) ^(a)	Friedler et al. (2004)	Friedler (2005)
Type of water	Mixed	Mixed	Mixed	Mixed	Mixed	Bathroom water	Bathroom water	Bathroom water	Bathroom water
pH	6.7 ± 0.1	7.0 ± 0.3	7.1 ± 0.2	7.0 ± 0.4	6.3-7				
SS (mg/l)	138 ± 21		25 ± 22	34 ± 15	158 ± 30	120	304	43	103
Alkalinity (mg/l)									
Hardness (mg/l)									
Turbidity (NTU)		33 ± 16	34 ± 17	51 ± 36				33	80
BOD ₅ (mg/l)	270 ± 60	36 ± 17	61 ± 22	58 ± 38	466 ± 66	170		59	95
BOD ₇ (mg/l)									
COD _{Cr} (mg/l)	686 ± 255	149 ± 63	163 ± 60	158 ± 104	839 ± 47			158	206
TOC (mg/l)						100	103		
Chloride (mg/l)									
T-N (mg/l)	14.0 ± 2.0	7.9 ± 2.5			34.3 ± 2.6				
TKN (mg/l)						17	11.2		9.3
NH ₄ -N (mg/l)		0.9 ± 0.8				2			3.6
NO ₃ -N (mg/l)		3.4 ± 1.6			3.0 ± 1.3	0.4			0.02
T-P (mg/l)	17.7 ± 5.1				22.8 ± 1.8				4.5
PO ₄ -P (mg/l)		0.6 ± 0.2				2	10		
Total Coliforms (CFU/100ml)		6.2*10 ⁵	3.5*10 ³ ± 3.1*10 ³	3.4*10 ³ ± 5.8*10 ³		1100			
Faecal Coliforms (CFU/100ml)					5*10 ⁷ ± 2*10 ⁷	200		5.6*10 ⁵	3.4*10 ⁵
Faecal Streptococci (CFU/100ml)	10 ⁶ ± 10 ⁵					44			
<i>E. Coli.</i> (CFU/100ml)		500	110 ± 224	15 ± 40					

Reference	Surendran, Weathley (1998)	Almeida et al. (1999)	Laak (1974)	Laine (2001)	Dixon et al. (1999)	Nolde (1999)	Laine (2001)	Liu et al. (2004)	Prathapar et al. (2005)
Type of water	Bath & shower	Bath	Bath	Bath	Bath	Shower	Shower	Shower	Shower
pH	7.6			7.57	7.5		7.52		7.4
SS (mg/l)	76	54		58	47		89	15-50	353
Alkalinity (mg/l)									15
Hardness (mg/l)									
Turbidity (NTU)	92			59.8	46.1		84.8		375
BOD ₅ (mg/l)	216		192	129			146	99-212	130
BOD ₇ (mg/l)						70-300			
COD _{Cr} (mg/l)	424	184	282	367	685	113-633	420	130-322	294
TOC (mg/l)	104			59.8			65.3		83.5
Chloride (mg/l)									
T-N (mg/l)				6.6			8.7		
TKN (mg/l)									
NH ₄ -N (mg/l)	1.56	1.1	1.34					0.6-1.0	
NO ₃ -N (mg/l)	0.9	4.2	0.36						28.7
T-P (mg/l)									
PO ₄ -P (mg/l)	1.63	5.3	0.94	0.4			0.3		
Total Coliforms (CFU/100ml)	6*10 ⁶			6350	370	10 ¹ -10 ³	6800		
Faecal Coliforms (CFU/100ml)	600				0	10 ⁻¹ -10 ¹			>200.5
Faecal Streptococci (CFU/100ml)									
<i>E. Coli.</i> (CFU/100ml)				82.7					>200.5

Reference	Pidou et al. (2006)	Pidou et al. (2006)	Almeida et al. (1999)	Surendran, Weathley (1998)	Laak (1974)	Laine (2001)	Smith et al. (2001) ^(b)	Al-Jayyousi (2003)	Prathapar et al. (2005)
Type of water	Shower	Shower	Shower	Wash basin	Wash basin	Wash basin	Wash basin	Wash basin	Wash basin
pH	7.2 ± 0.1	7.5 ± 0.2		8.1		7.32			7.1
SS (mg/l)			200	40		153	36		505
Alkalinity (mg/l)									13.3
Hardness (mg/l)									
Turbidity (NTU)	21 ± 6	44 ± 9		102		164			133
BOD ₅ (mg/l)	100 ± 23	186 ± 37		252	236	155	33	109	42
BOD ₇ (mg/l)									
COD _{Cr} (mg/l)	292 ± 68	498 ± 98	221	433	383	587	95	263	58
TOC (mg/l)				40		99			70
Chloride (mg/l)									
T-N (mg/l)	13.5 ± 3.3	14.1 ± 3.1				10.4		9.6	
TKN (mg/l)							4		
NH ₄ -N (mg/l)	0.4 ± 0.4	1.0 ± 0.3	1.2	0.53	1.15				
NO ₃ -N (mg/l)	7.5 ± 2.5	6.3 ± 1.2	6.3	0.34	0.28				10.2
T-P (mg/l)								2.58	
PO ₄ -P (mg/l)	0.3 ± 0.1	1.3 ± 0.1	19.2	45.5	48.8	0.4			
Total Coliforms (CFU/100ml)	2*10 ⁴			5*10 ⁴		9420	2.4*10 ³ - >2.4*10 ⁶		
Faecal Coliforms (CFU/100ml)				32					>200.5
Faecal Streptococci (CFU/100ml)									
<i>E. Coli.</i> (CFU/100ml)	260					10	0->2.4*10 ⁶		>200.5

Reference	Almeida et al. (1999)	Almeida et al. (1999)	Christova-Boal et al. (1996)	Surendran, Weathley (1998)	Laak (1974)	Siegrist et al. (1976) ^(a)	Siegrist et al. (1976) ^(a)	Prathapar et al. (2005)	Dixon et al. (1999)
Type of water	Wash basin	Washing machine	Laundry water	Washing machine	Laundry water	Laundry water ^(d)	Laundry water ^(e)	Laundry water	Washing machine ^(c)
pH			9.3-10.0	8.1				8.3	9.5
SS (mg/l)	181	165	88-250	68		280	120	315	465
Alkalinity (mg/l)			83-200					28.3	
Hardness (mg/l)									
Turbidity (NTU)			50-210	108				444	255
BOD ₅ (mg/l)			48-290	472	282	380	150	180	
BOD ₇ (mg/l)									
COD _{Cr} (mg/l)	221	1164		725	725			231	2950
TOC (mg/l)				110		280	100	175	
Chloride (mg/l)			9.0-88						
T-N (mg/l)									
TKN (mg/l)			1.0-40			21	6		
NH ₄ -N (mg/l)	0.3	2.0	<0.1-1.9	10.7	11.3	0.7	0.4		
NO ₃ -N (mg/l)	6.0	2.0	0.10-0.31	1.6	1.26	0.6	0.4	25.8	
T-P (mg/l)			0.062-42						
PO ₄ -P (mg/l)	13.3	21.0		101	171.0	57	21		
Total Coliforms (CFU/100ml)			2.3*10 ³ -3.3*10 ⁵	7*10 ⁵		1.8*10 ⁴	5.3*10 ³		10 ⁴
Faecal Coliforms (CFU/100ml)			110-1.09*10 ³	728		1.4*10 ³	3.2*10 ²	>200.5	50
Faecal Streptococci (CFU/100ml)			23-<2.4*10 ³			2.1*10 ²	75		
<i>E. Coli.</i> (CFU/100ml)								>200.5	

Reference	Siegrist et al. (1976) ^(a)	Almeida et al. (1999)	Surendran, Weathley (1998)	Laak (1974)
Type of water	Kitchen sink	Kitchen sink	Kitchen sink	Kitchen sink
pH				
SS (mg/l)	720	235		
Alkalinity (mg/l)				
Hardness (mg/l)				
Turbidity (NTU)				
BOD ₅ (mg/l)	1460		536	676
BOD ₇ (mg/l)				
COD _{Cr} (mg/l)		644	936	1380
TOC (mg/l)	880			
Chloride (mg/l)				
T-N (mg/l)				
TKN (mg/l)	74			
NH ₄ -N (mg/l)	6	0.3	4.6	5.44
NO ₃ -N (mg/l)	0.3	5.8	0.45	0.56
T-P (mg/l)				
PO ₄ -P (mg/l)	74	26.0	15.6	12.7
Total Coliforms (CFU/100ml)				
Faecal Coliforms (CFU/100ml)				
Faecal Streptococci (CFU/100ml)				
<i>E. Coli.</i> (CFU/100ml)				

^(a) referenced in Hrudevy and Raniga (1980); ^(b) referenced in Lazarova et al. (2003); ^(c) 1st and 2nd flushes only; ^(d) Wash cycle; ^(e) Rinse cycle;

**Appendix II:
Technology library.**

Rainwater and grey water in buildings: project report en case studies.**D. Brewer, R. Brown and G. Stanfield. 2000****Scheme details:**

Location: 3 bedroom terrace house (3 adults) Liverpool, UK.

Source: bath/shower, bathroom basin and toilet hand basin.

Application: flushing of 2 toilets.

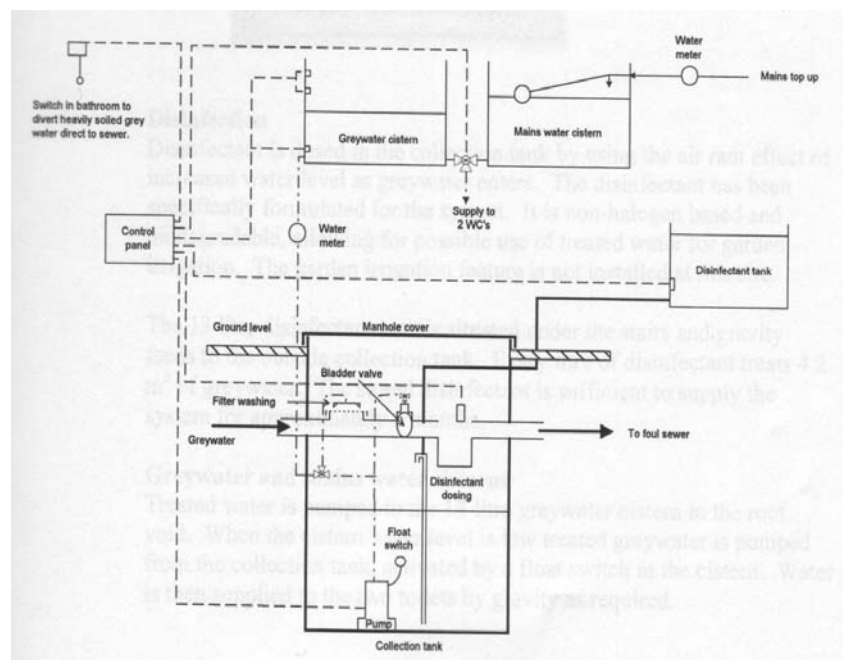
**Design:**200 μ m fine mesh filter.

Underground collection tank.

Disinfection tank: 13L.

GW cistern: 18L.

Performance:

	Coliforms (cfu/100mL)	E. Coli (cfu/100mL)	COD (mg/L)	Turbidity (NTU)	Chloride (ppm)	Ammonia (ppm)	Phosphate (ppm)
Collection tank 1	TNTC	TNTC	95	1.88	24.11	12.39	5.82
Collection tank 2	TNTC	TNTC	52	2.34	23.46	12.96	4.82
Toilet cistern 1	0	0	13	0.37	5.61	<0.5	32.59
Toilet cistern 2	91	ND	9	0.90	20.85	7.43	1.95

TNTC: Too numerous to count. ND: Not detectable.

Costs:

System: £1000.

Notes:

Not enough GW => main water is supplied to the toilets.

No flushing for 48hrs => GW cistern drained in the collection tank.

Not used for 4 days => Collection tank drained in the sewer.

Maintenance: refill disinfectant every 3 months and annual check of the filter.

Disinfectant dyed in blue to notice the use of GW in the toilets.

The system failed due to poor installation...

Rainwater and grey water in buildings: project report en case studies.**D. Brewer, R. Brown and G. Stanfield. 2000****Scheme details:**

Location: 5 bedroom house (3 adults, 3 children (<15) and 3 dogs) Maidenhead, UK.

Monitoring between February 1999 and March 2000.

Source: 2 baths, 2 showers and 3 hand basins.

Application: flushing of 5 toilets.

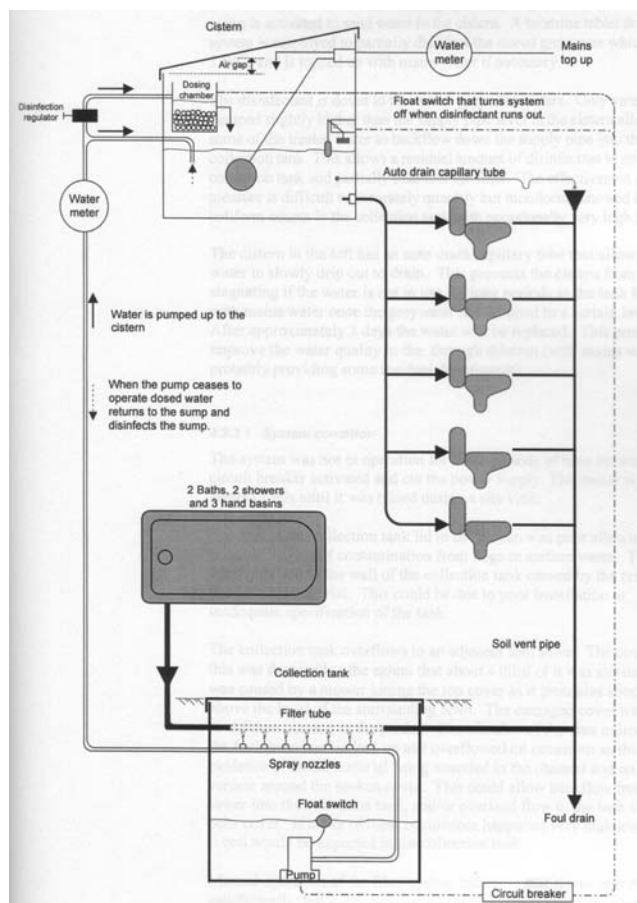
**Performances:**

	Collection tank	Toilet cistern
Coliforms (cfu/100mL)	$2.2 \cdot 10^5 \pm 5.9 \cdot 10^5$ (17)	13 ± 47 (18)
E. Coli (cfu/100mL)	24 ± 66 (17)	0 ± 0 (18)
COD (mg/L)	157 ± 73 (16)	47 ± 50 (19)
Turbidity (NTU)	21 ± 5 (12)	7 ± 8 (12)
Chloride (ppm)	46 ± 14 (16)	46 ± 16 (14)
Ammonia (ppm)	2.3 ± 1.7 (14)	1.5 ± 1.3 (12)

Design:260 μ m fine mesh screen.

Underground collection tank: 180L.

Grey water cistern.

Disinfectant: bromine tablet.

Costs (estimations):

Water savings: £68/annum.

Capital costs: £1625.

Operational costs: £4 (1st year) and then £49/annum.

Notes:

Maintenance: annual addition of disinfectant and checking of the self-cleaning filter.

Process often stopped due to electrical problems.

Treated water was often cloudy.

House water consumption: 24% toilet flushing / 76% other.

Toilet flushing: 54% grey water / 46% mains top-up.

Rainwater and grey water in buildings: project report en case studies.**D. Brewer, R. Brown and G. Stanfield. 2000****Scheme details:**

Location: Student hall of residence, 23 single occupancies.

Monitoring between October 1999 and April 2000.

Source: baths, showers, wash basins and laundry.

Application: flushing of 9 toilets.

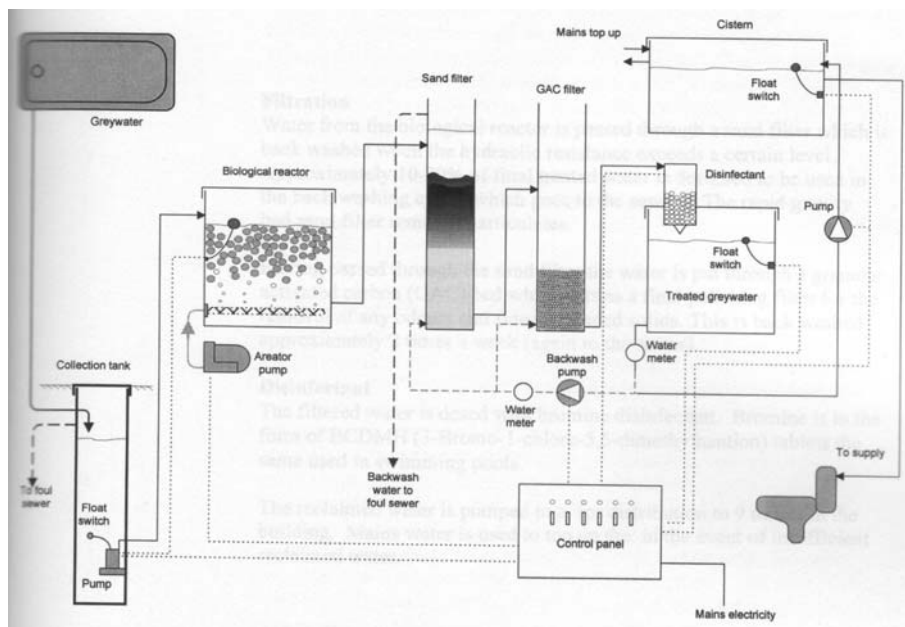
**Design:**

Collection tank: 2000L.

Biological reactor (Bacteria grow on a plastic media).

Sand filter.

Granular activated carbon (GAC).

Disinfection (bromine).

Treated GW cistern.

Performance:

	Coliforms (cfu/100mL)	E. Coli (cfu/100mL)	COD (mg/L)	Turbidity (NTU)	Chloride (ppm)	Ammonia (ppm)
Grey water	$7.3 \cdot 10^5 \pm 7.2 \cdot 10^5$ (11)	877 ± 1845 (11)	201 ± 70 (11)	212 ± 369 (12)	36 ± 3 (8)	4 ± 3 (8)
Treated water	3 ± 13 (14)	0 ± 0 (14)	62 ± 73 (14)	5 ± 4 (15)	39 ± 2 (9)	0.4 ± 0.2 (9)
Toilet cistern	0 ± 0 (14)	0 ± 0 (14)	182 ± 254 (13)	5 ± 5 (15)	36 ± 2 (9)	0.3 ± 0.2 (9)

Costs:

Water savings: £166/annum.

Capital costs (estimation): £30000. Capital could be reduced to £12000.

Operational costs: £611/annum.

Electricity consumption: £3.43/m³ of treated grey water use for toilet flushing.**Notes:**

Toilet flushing: 38% grey water / 62% mains top-up.

Annual grey water treated: 263m³ of which only 62% were used for toilet flushing, the remaining 38% being used for filter back washing.

A bigger collection tank would allow a bigger production of treated grey water.

Processing of combined domestic bath and laundry waste waters for reuse as commode flushing water.

W. D. Hypes, C. E. Batten, and J. R. Wilkins. 1975

Scheme details:

Location: pilot plant, USA.

Source: bath/shower and laundry.

12-day experiment.

Application: toilet flushing.

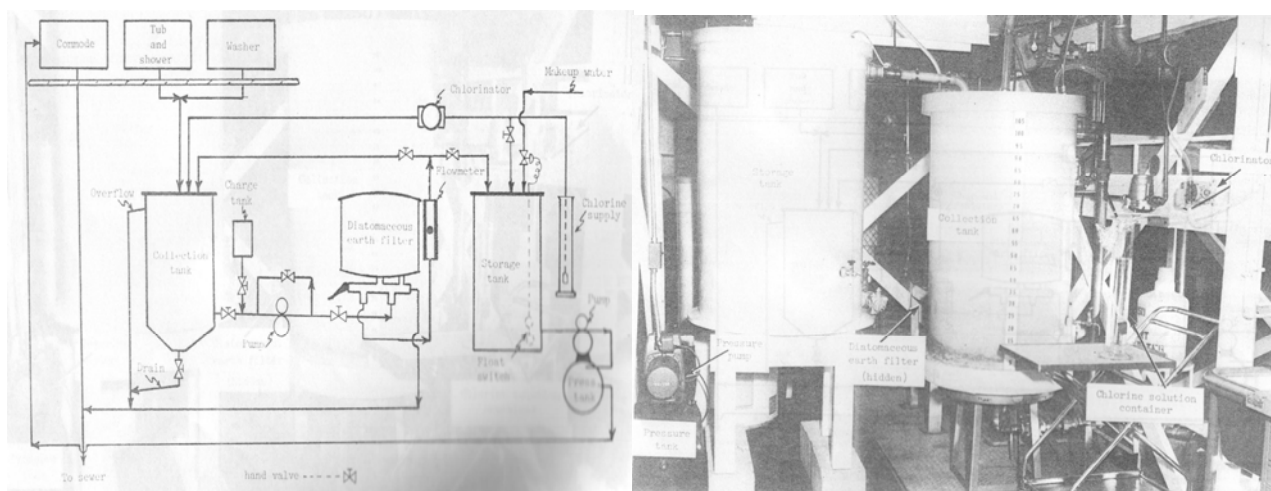

Design:

Collection tank.

Diatomaceous earth filter (0.7 m²).

Hydraulic load: 0.32 m³/m²/d

Disinfection (chlorine, 30mg/L).

Treated GW cistern.

Performance:

Physical and chemical:

	Total solids (ppm)	Turbidity (NTU)	TOC (ppm)	Phosphate (ppm)	Nitrate (ppm)	Chloride (ppm)	Ammonia (ppm)
Collection tank (10)	549 ± 174	17 ± 20	43 ± 16	138 ± 65	0.2 ± 0.3	21 ± 5	0.8 ± 0.6
Storage tank (11)	460 ± 80	9 ± 4	35 ± 16	86 ± 31	0.3 ± 0.5	24 ± 3	0.8 ± 0.9

Biological:

	Collection tank	Storage tank	Commode tank
Total Coliforms (cfu/100mL)	2.4*10 ⁶ ± 5.0*10 ⁶ (9)	1.9*10 ⁴ ± 2.7*10 ⁴ (12)	34 ± 115 (12)

Costs: /

Notes:

Water use (average):

Toilet flushing: 212L/day.

Grey water (1 bath, 1 shower and 1 laundry load per day): 295L/day.

Loss (overflows and drains): 74L/day.

Main water top-up: 21L/day.

Energy consumption: 0.695kWh/day.

Processing of combined domestic bath and laundry waste waters for reuse as commode flushing water.

W. D. Hypes, C. E. Batten, and J. R. Wilkins. 1975

Scheme details:

Location: pilot plant, USA.

Source: bath/shower and laundry.

6-day experiment.

Application: toilet flushing.

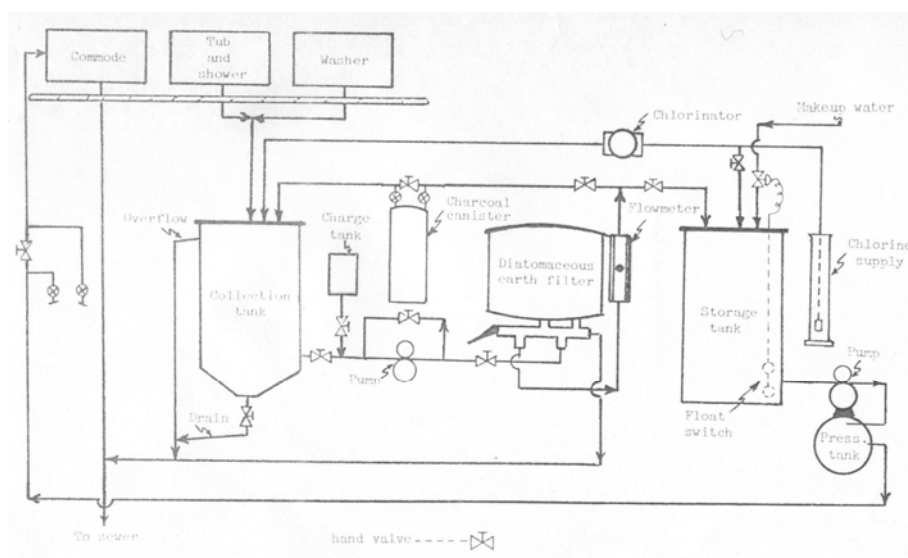

Design:

Collection tank.

Diatomaceous earth filter (0.7 m²).

Hydraulic load: 0.24 m³/m²/d.

Charcoal adsorption (28L).

Disinfection (chlorine, 30mg/L).

Treated GW cistern.

Performance:

	Total solids (ppm)	Turbidity (NTU)	TOC (ppm)	Phosphate (ppm)	Total Coliforms (cfu/100mL)
Collection tank	500 ± 144 (4)	23 ± 14 (4)	85 ± 42 (4)	123 ± 82 (4)	1.4*10 ⁵ ± 3.2*10 ⁵ (6)
Storage tank	394 ± 42 (4)	9 ± 2 (4)	32 ± 15 (4)	108 ± 29 (4)	1.2*10 ³ ± 2.2*10 ³ (6)
Commode tank	-	-	-	-	4 ± 10 (9)

Costs: /

Notes:

Water use (average):

Toilet flushing: 209L/day.

Grey water: 244L/day.

Loss (overflows and drains): 73L/day.

Main water top-up: 46L/day.

Energy consumption: 0.695kWh/day.

Water reuse and recycling in Japan.
International Technology Service.
Overseas mission of science & technology experts. 2000

Scheme details:

Location: Tokyo dome, Japan.

Commissioned: 1987 (currently running).

Source: mixed grey water (including kitchen waste) and rainwater.

Application: flushing of 458 toilets and urinals.

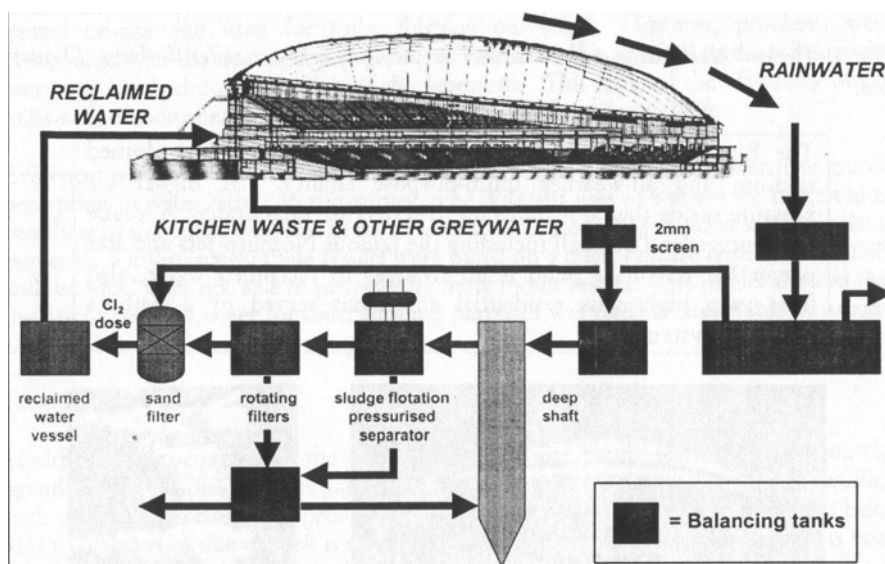

Design:

Screening (2mm).

Deep shaft (HRT: 2-3hrs).

Sludge flotation pressurised separator (HRT: 8hrs).

Rotating cloth filter.

Sand filter.

Disinfection: chlorine (0.1ppm residual).

Treated water vessel (626m³).

Performance:

	BOD (mg/L)	COD (mg/L)	Suspended Solids (mg/L)	E. Coli (cfu/100mL)
Grey water	336 (170)	243 (120)	207 (92)	-
Reclaimed water	20 (1)	(6)	10 (1)	(10)

Figures in brackets indicate samples at the time, the plant being under-loaded.

Costs: /

Notes:

Plant designed to treat 622m³/day. (115m³: kitchen waste, 287m³: other grey waters and 220m³: rainwater).

In operation 15hrs per day.

All the treatment processes were at the time under-loaded.

Reedbeds for greywater treatment – case study in Santa Elena-Monteverde, Costa Rica, Central America.

S. Dallas, B. Scheffe and G. Ho. 2004

Ecological Engineering n°23, pp: 55-61.

Scheme details:

Location: 3 houses (7 people), Monteverde, Costa Rica.

Commissioned: February 2001.

Source: grey water (all domestic wastewater except toilet wastewater).

Application: irrigation.

Water quality standards:

BOD < 40 mg/L.

Faecal coliforms < 1000 cfu/100 mL for irrigation of food crops with further processing.

Faecal coliforms < 100 cfu/100 mL for irrigation of food crops without further processing or other urban reuse (e.g. watering of parks).

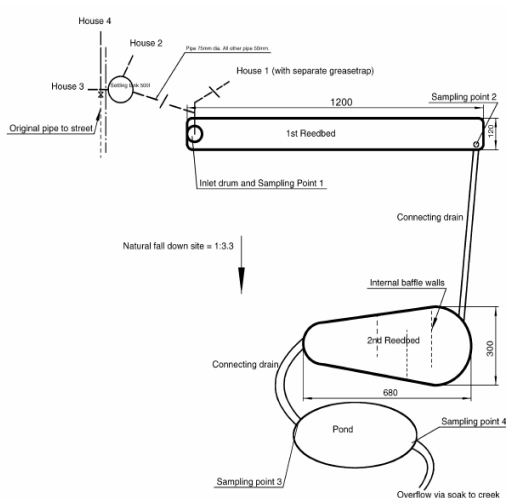

Design:

Settling tank (500L).

Reedbed 1 (14m long, 1.2m wide and 0.6m deep (17m²), reeds: *Coix lacryma-jobi*, HRT: 4.5 days).

Reedbed 2 (~oval shape 6m×3m and 0.6m deep (13m²), reeds: *Coix lacryma-jobi*, HRT: 3.4 days).

Pond (2.5m³) containing fish and aquatic plants.

Soakage area.

Flow rate: 755L/day.

Performance:

	Season	Turbidity (NTU)	BOD (mg/L)	Faecal coliform (cfu/100mL)	Phosphate (mg/L)
Inlet	(n=11)	96 ± 39	167 ± 47	1.5*10 ⁸ ± 4.6*10 ⁸	16 ± 15
1 st Reedbed	Dry season (n=6)	8 ± 4	7 ± 2	6.3*10 ³ ± 6.9*10 ³	18 ± 16
	Wet season (n=5)	7 ± 3	10 ± 6	3.0*10 ⁴ ± 4.5*10 ⁴	7 ± 5
2 nd Reedbed	Dry season (n=7)	2 ± 2	1 ± 1	16 ± 30	11 ± 16
	Wet season (n=7)	2 ± 2	3 ± 5	122 ± 266	3 ± 2
Pond	Dry season (n=5)	5 ± 1	3 ± 2	65 ± 90	5 ± 5
	Wet season (n=8)	3 ± 2	2 ± 2	198 ± 494	3 ± 2

Costs:

Capital cost: US\$1000.

Maintenance: 1US\$/month.

Notes:

The Faecal Coliform standard for reuse 100mL for irrigation of food crops without further processing or other urban reuse is not met during the wet season.

Good general BOD removal with a BOD in the effluent of less than 10mg/L (much lower than the standard required, 40mg/L).

Experiences on grey water reuse for toilet flushing in a hotel.

J. G. March, M. Gual and F. Orozco. 2004

Desalination n°164, pp: 241-247.

Scheme details:

Location: 81-room hotel in Mallorca Island, Spain.

Commissioned: May 2001.

Source: baths and hand basins.

Application: toilet flushing.

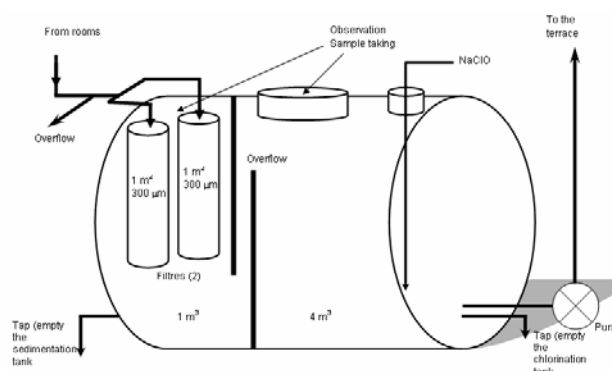
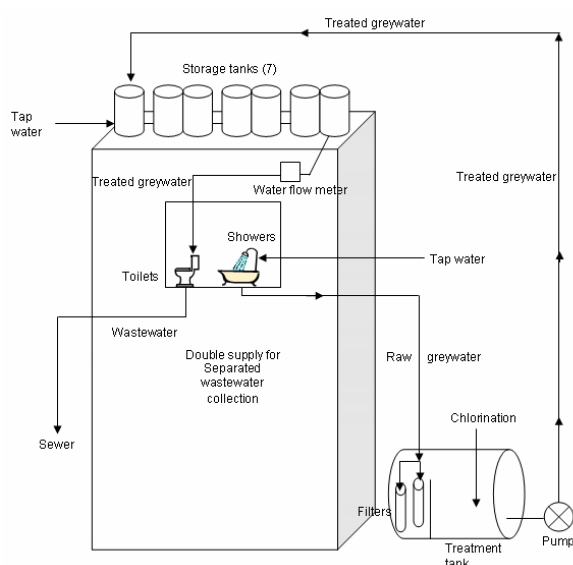

Design:

2 Nylon sock-type filters (0.3mm mesh, 1m²).

Sedimentation tank (1m³).

Disinfection tank (4m³): sodium hypochlorite (75mg/L, >1.0mg/L residual in toilet tank).

7 Storage tank (4.5m³ each) on the top floor.
HRT: 48hrs.

Performance:

	TOC (mg/L)	COD (mg/L)	Suspended Solids (mg/L)	Total-N (mg/L)	Turbidity (NTU)
Grey water	58 ± 42 (18)	171 ± 130 (12)	44 ± 31 (12)	11.4 ± 9.4 (12)	20 ± 13 (24)
Treated water	40 ± 8 (18)	78 ± 30 (12)	19 ± 3 (12)	7.1 ± 2.9 (12)	17 ± 8 (24)

Costs:

Capital cost:

Storage tanks: €3000.

Pump and flow control: €2000.

Plumbing (dual piping): €12000.

Energy and chemicals: 0.33€/m³.

Labour: 0.42€/m³.

Savings: 1.09€/m³.

Estimated payback: 14 years (with the system operational 7 months per year).

Notes:

Water consumption in the hotel:

Total water use: 146 L/day/person.

Toilet flushing: 36 L/day/person (25%) or 5.2 m³/day.

Grey water reuse systems for toilet flushing in multi-storey buildings – over ten years of experience in Berlin.

E. Nolde. 1999

Urban water n°1, pp: 275-284.

Scheme details:

Location: Multi-storey building (70 people) in Berlin, Germany.

Commissioned: 1989.

Source: showers, baths and hand basins.

Application: toilet flushing.

Water quality standards:

BOD₇<5mg/L.

Total coliforms<100/mL

Faecal coliforms<10/mL

Pseudomonas aeruginosa<1/mL

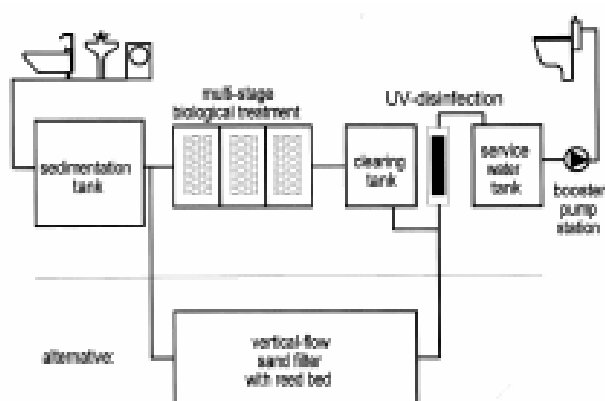

Design:

Funnel-shaped sedimentation tank.

4-stage rotary biological contactor.

Clearing tank.

UV disinfection.

Footprint: 15m².

Grey water: 30-35L/person/day.

Performance:

	BOD ₇ (BOD ₅) (mg/L)	COD (mg/L)	Total-P (mg/L)	Total-N (mg/L)	Total Coliforms (cfu/100mL)	Faecal coliforms (cfu/100mL)
Grey water (bath and shower)	50-100 (43-85)	100-200	5-10	0.2-0.6	10 ⁴ -10 ⁵	10 ¹ -10 ³
Grey water (bath, shower and laundry)	150-250 (128-214)	250-430	-	-	10 ⁶ -10 ⁸	10 ⁶ -10 ⁸
Treated water (1mg/L BOD ₅ = 1.17mg/L BOD ₇)	<5 (<4)	-	-	-	<10000	<1000

Costs: /

Notes:

A 2-stage rotary biological contactor was first installed then changed for a 4-stage in 1997.

Maintenance: 0.2h/week.

Energy consumption: 1.5kWh/m³.

Grey water reuse systems for toilet flushing in multi-storey buildings – over ten years of experience in Berlin.

E. Nolde. 1999

Urban water n°1, pp: 275-284.

Scheme details:

Location: 2-person household in Berlin, Germany.

Commissioned: 1995.

Source: shower and bath.

Application: toilet flushing.

Water quality standards:

BOD₇<5mg/L.

Total coliforms<100/mL

Faecal coliforms<10/mL

Pseudomonas aeruginosa<1/mL



Design:

2-stage fluidized bed reactor (165L: stage1: 105L and stage 2: 60L).

Bio-film attached on cube-shaped polyurethane.

UV disinfection.

Grey water: 15-20L/person/day.

Performance:

	BOD ₇ (BOD ₅) (mg/L)	COD (mg/L)	TOC (mg/L)	Total Coliforms (cfu/100mL)	Faecal coliforms (cfu/100mL)
Grey water	70-300 (60-256)	113-633	26-95	10 ³ -10 ⁵	10 ¹ -10 ³
Treated water	<5 (<4)	-	4-8	<10000	<1000

(1mg/L BOD₅ = 1.17mg/L BOD₇)

Costs: /

Notes:

System placed above the toilet in the bathroom (small footprint).

Wastewater treatment by greywater separation: Outline for a biologically based greywater purification plant in Sweden.

F. Günther. 2000

Ecologica1 Engineering n°15, pp: 139-146.

Scheme details:

Location: building at the technical university college of Kalmar (500 students), Sweden.

Commissioned: August 1997.

Source: hand- and dish-washing water.

Application: hand washing and toilet flushing.

Water quality standards: requirements of the local health office

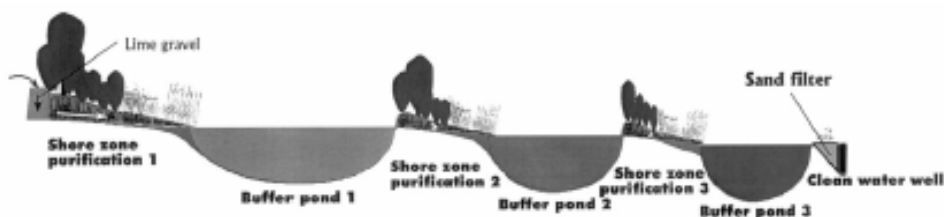

Design:

Triplicate soil layer infiltration-wetland-pond system with a lime-gravel at the beginning and a sand filter at the end (Wetpark).

Plants used in the wetland parts: *Alnus*, *Salix* species and *Aegopodium podagraria*-*Filipendula ulmaria*-*Cirsium oleraceum*.

Plants on the shore of the ponds: reed *Phragmites communis*, cattail and *Typha latifolia*.

Some fishes and crayfishes were introduced in the ponds.

Total retention time: 1 year.

Flow rate: 700m³/year.

Footprint: 1200m².

Performance:

	BOD ₇ (mg/L)	Nitrogen (mg/L)	Phosphorus (mg/L)	Thermo-stable Coliforms (cfu/100mL)	Faecal streptococci (cfu/100mL)
Grey water	47±25 (17)	3.72±2.21 (6)	3.73±2.65 (6)	94427±130164 (14)	35848±34732 (13)
Pond 1	0.5±0.9 (3)	0.975±0.917 (3)	0.372±0.576 (6)	25±37 (17)	361±553 (17)
Pond 2	0±0 (6)	(0)	(0)	96±52 (3)	432±478 (3)
Pond 3	0.8±1.3 (9)	1.9 (1)	0.020 (1)	11±12 (6)	15±12 (6)
Reception well	0±0 (9)	1.618±1.546 (5)	0.022±0.005 (5)	172±295 (9)	43±53 (9)

Costs:

Construction costs: 375\$ per connected person.

Notes:

Rainwater from the roof of the building is let into the Wetpark.

Greywater reclamation for non-potable reuse.**S. Surendran and A. D. Wheatley. 1998****J. CIWEM n°12, pp: 406-413.****Scheme details:**

Location: student halls of residence (40 students) in Loughborough University, United Kingdom.

Commissioned: Oct. 1997 – Oct. 2000

Source: greywater.

Application: toilet flushing

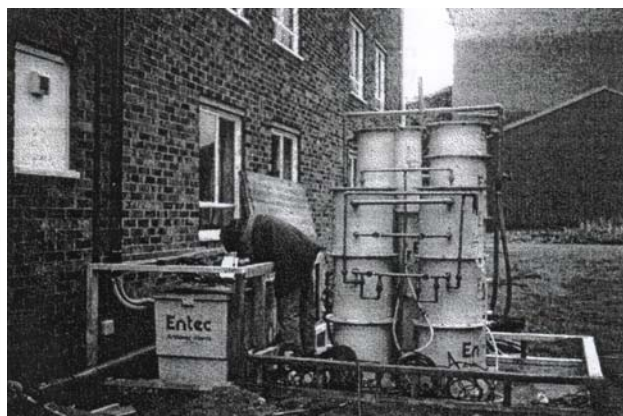
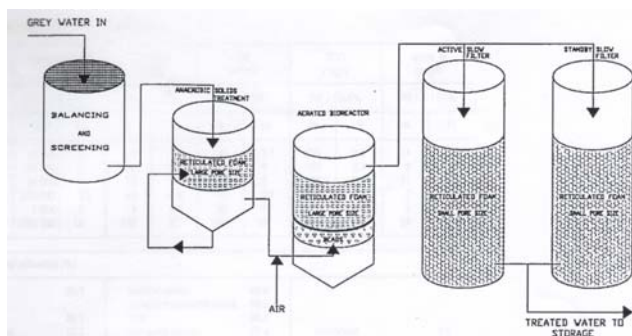
**Design:**

Balance tank (1400L) with screening.

Aerated biofilter.

Slow deep-bed filter.

Activated carbon (optional).

2 treated-water storage tank (700L and 500L)

Performance:

Greywaters characteristics:

	Bath/Shower	Washbasin	Washing machine	Kitchen sink
BOD (mg/L)	216	252	472	536
COD (mg/L)	424	433	725	936
NH ₄ ⁺ (mg/L)	1.56	0.53	10.7	4.6
NO ₃ ⁻ (mg/L)	0.9	0.34	1.6	0.45
PO ₄ ³⁻ (mg/L)	1.63	45.5	101	15.6
Total coliforms (cfu/100mL)	6*10 ⁵	5*10 ⁴	7*10 ⁵	-
Faecal coliforms (cfu/100mL)	600	32	728	-
Turbidity (NTU)	92	102	108	-
TOC (mg/L)	104	40	110	-
SS (mg/L)	76	40	68	-

	BOD (mg/L)	Turbidity (NTU)	Total coliforms (cfu/100mL)	Faecal coliforms (cfu/100mL)	TOC (mg/L)	SS (mg/L)
Treated greywater	8.5±13.4	1.1±0.5	995±111	4±4	9.8±6.7	5.7±3.5

Costs:

Calculated cost for retro-fit system:

Total capital cost (plant, plumbing and installation): £3345.

O & M: £128/annum.

Electricity: £43/annum.

Labour and materials: £85/annum.

Water saving: £516/annum.

Payback: 8-9 years.

Estimated cost in new building:

Total capital cost (plant, plumbing and installation): £1720.

O & M: £128/annum.

Water saving: £516/annum.

Payback: 4-5 years.

Water quality study of greywater treatment systems.

C. P. Gerba, T. M. Staub, J. B. Rose, M. M. Karpiscak, K. E. Foster and R. G. Brittain. 1995
Water Resources Bulletin (American Water Resources Association) vol. 31, n°1, pp: 109-116.

Scheme details:

Location: Casa del Agua (2 adults and 1 child), Arizona, United States.

Commissioned: 1985.

Source: washing machine, one side of the kitchen sink, bathroom washbasin, bath and shower.

Application: irrigation of lawn, shrubs and trees and toilet flushing.

Water quality standards: water reuse regulations in the State of Arizona.

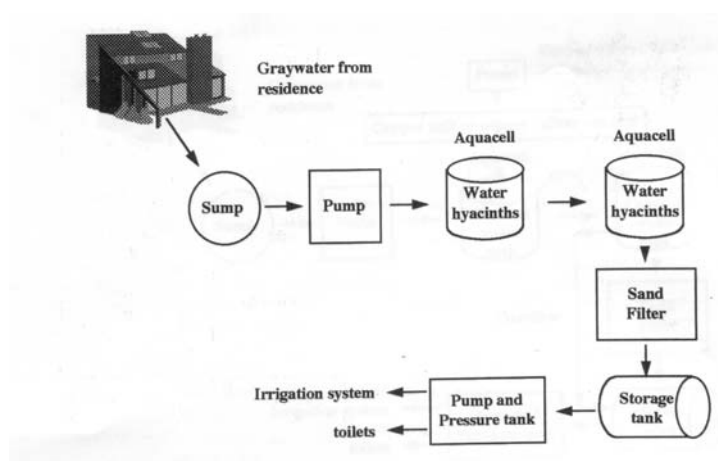
**Design:**

Sump tank (200L).

2 galvanized tanks (Aquacell) containing water hyacinths (*Eichhornia Crassipes*) (1200L).

Retention time in the 2 tanks: 6 days.

Sand filter (depth: 0.38m, surface area: 3m²). Tomatoes, peppers, and other plants were grown in the sand filter which assisted in soil aeration.

Storage tank (3025L).

Performance:

	Turbidity (NTU)	BOD (mg/L)	Suspended solids (mg/L)	Nitrate (mg/L)	Total Coliforms (Log 10 cfu/100mL)	Faecal coliforms (Log 10 cfu/100mL)
Greywater	64.1±33.2	119.8±21.7	40.3±10.0	1.8±1.6	7.6±0.8	7.0±1.0
Treated greywater	3.9±2.4	3.7±1.2	16.8±13.3	1.5±1.4	4.7±0.8	3.5±1.0

Costs: /

Notes: /

Water quality study of greywater treatment systems.

C. P. Gerba, T. M. Staub, J. B. Rose, M. M. Karpiscak, K. E. Foster and R. G. Brittain. 1995
Water Resources Bulletin (American Water Resources Association) vol. 31, n°1, pp: 109-116.

Scheme details:

Location: Casa del Agua (2 adults and 1 child), Arizona, United States.

Commissioned: 1985.

Source: washing machine, one side of the kitchen sink, bathroom washbasin, bath and shower.

Application: irrigation of lawn, shrubs and trees and toilet flushing.

Water quality standards: water reuse regulations in the State of Arizona.

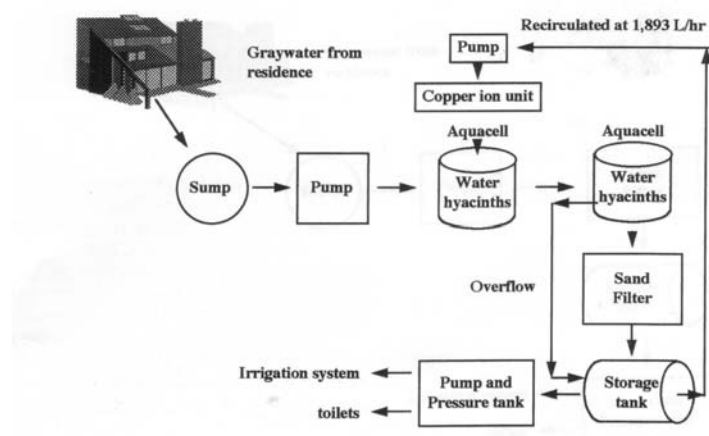
**Design:**

Sump tank (200L).

2 galvanized tanks (Aquacell) containing water hyacinths (*Eichhornia Crassipes*) (1200L).

Retention time in the 2 tanks: 6 days.

Sand filter (depth: 0.38m, surface area: 3m²). Tomatoes, peppers, and other plants were grown in the sand filter which assisted in soil aeration.

Storage tank (3025L).

Recirculation of the greywater (1893L/h) from the storage tank into the first Aquacell.

A swimming pool purity unit providing copper ions for disinfection was added to the recirculation loop.

Performance:

	Turbidity (NTU)	Suspended solids (mg/L)	Nitrate (mg/L)	Total Coliforms (Log 10 cfu/100mL)	Faecal coliforms (Log 10 cfu/100mL)
Greywater	78.6±28.5	35.8±31.4	2.3±2.0	7.2±0.9	5.7±1.4
Treated greywater	3.6±3.7	4.7±5.7	1.4±1.0	5.8±0.9	4.4±1.0

Costs: /

Notes: /

Water quality study of greywater treatment systems.

C. P. Gerba, T. M. Staub, J. B. Rose, M. M. Karpiscak, K. E. Foster and R. G. Brittain. 1995
Water Resources Bulletin (American Water Resources Association) vol. 31, n°1, pp: 109-116.

Scheme details:

Location: Casa del Agua (2 adults and 1 child), Arizona, United States.

Commissioned: 1985.

Source: washing machine, one side of the kitchen sink, bathroom washbasin, bath and shower.

Application: irrigation of lawn, shrubs and trees and toilet flushing.

Water quality standards: water reuse regulations in the State of Arizona.

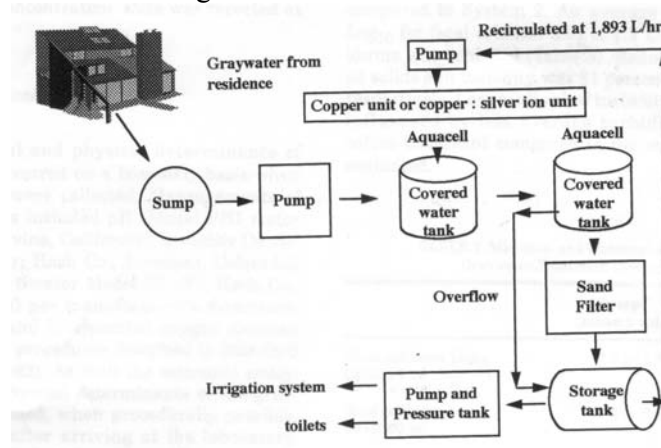
**Design:**

Sump tank (200L).

2 galvanized tanks (Aquacell) covered with Styrofoam (1200L).

Retention time in the 2 tanks: 6 days.

Sand filter (depth: 0.38m, surface area: 3m²). Tomatoes, peppers, and other plants were grown in the sand filter which assisted in soil aeration.

Storage tank (3025L).

Recirculation of the greywater (1893L/h) from the storage tank into the first Aquacell.

A swimming pool purity unit providing copper ions or copper and silver ions for disinfection was added to the recirculation loop.

Performance:

System		Turbidity (NTU)	Suspended solids (mg/L)	Nitrate (mg/L)	Total Coliforms (Log 10 cfu/100mL)	Faecal coliforms (Log 10 cfu/100mL)
Copper ions	Greywater	52.6±42.9	48.0±49.0	2.8±1.2	8.3±1.2	5.4±0.6
	Treated greywater	8.8±3.5	9.3±6.7	2.3±2.0	7.0±1.0	4.6±0.5
Copper and silver ions	Greywater	15.3±8.3	19.3±12.0	2.0±1.2	8.8±0.5	6.5±1.3
	Treated greywater	2.9±3.5	7.0±6.8	2.0±0.8	5.8±0.6	4.4±0.7

Costs: /

Notes: /

Water quality study of greywater treatment systems.

C. P. Gerba, T. M. Staub, J. B. Rose, M. M. Karpiscak, K. E. Foster and R. G. Brittain. 1995
Water Resources Bulletin (American Water Resources Association) vol. 31, n°1, pp: 109-116.

Scheme details:

Location: Casa del Agua (2 adults and 1 child), Arizona, United States.

Commissioned: 1985.

Source: washing machine, one side of the kitchen sink, bathroom washbasin, bath and shower.

Application: irrigation of lawn, shrubs and trees and toilet flushing.

Water quality standards: water reuse regulations in the State of Arizona.

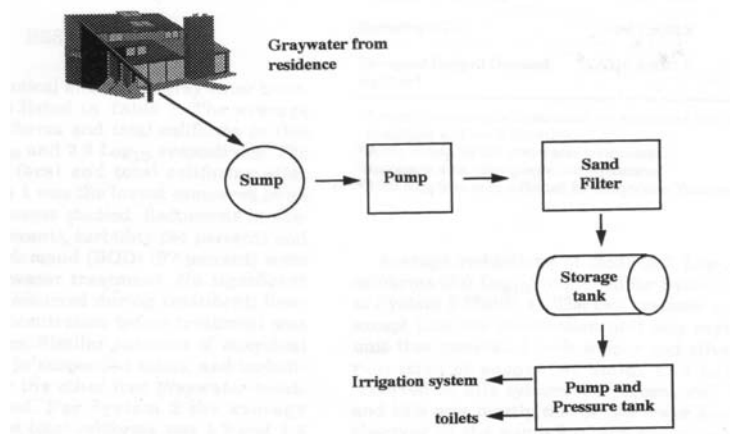
**Design:**

Sump tank (200L).

20-micron nominal porosity cartridge filter.

Storage tank (3025L).

Performance:

	Turbidity (NTU)	Suspended solids (mg/L)	Nitrate (mg/L)	Total Coliforms (Log 10 cfu/100mL)	Faecal coliforms (Log 10 cfu/100mL)
Greywater	20.5±15.7	19.1±22.2	3.0±1.1	8.3±0.5	7.2±1.2
Treated greywater	6.7±8.1	7.7±5.3	2.6±0.7	6.3±1.0	5.2±1.0

Costs: /

Notes: /

Microbiological greywater treatment and recycling in an apartment building.**E. Santala, J. Uotila, G. Zaitsev, R. Alasiurua, R. Tikka and J. Tengvall. 1998.****Proceedings of the Advanced Wastewater Treatment, Recycling and Reuse conference, Milano, Italy. 14-16 Sept. 1998****Scheme details:**

Location: 3-storey apartment building (6 families) in Oulu, Finland.

Commissioned: 1996.

Source: laundry, washbasin and shower.

Application: toilet flushing.

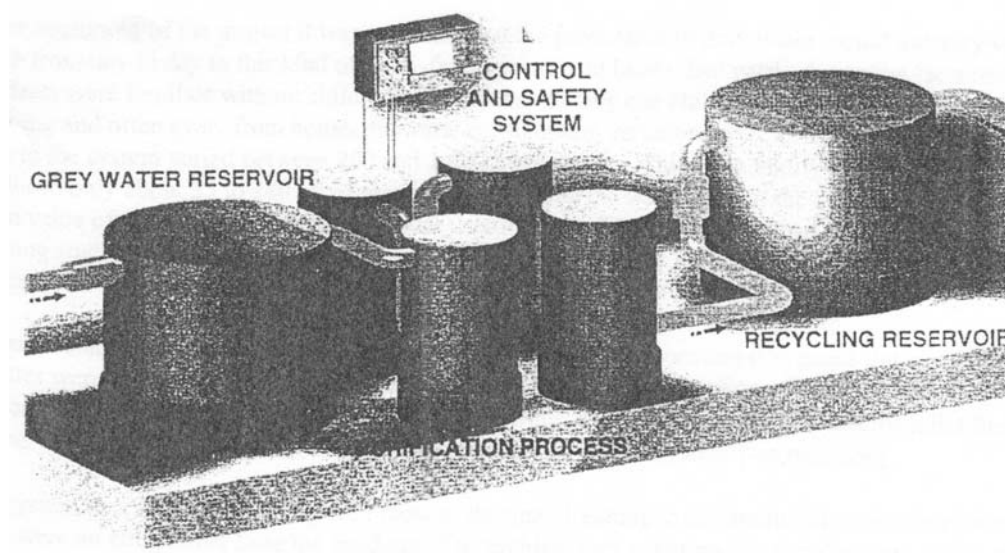
**Design:**

Reservoir tank (1000L).

4 aerated process tanks filled with a carrier material with specially selected microbial strains.

UV filter

Recycling reservoir tank (1000L).

Control, regulation and supervision of the process with a computer.

Performance:

	Influent	Effluent
COD (mg/L)	Up to 8000	15-75
PO ₄ ³⁻	Up to 30	0.1
NH ₄ ⁺	Up to 25	0.5
Heterotrophic bacteria (cfu/mL)	Up to 1.8*10 ⁶	<100
Faecal coliforms (cfu/100mL)	Up to 1.4*10 ⁶	0-20

Costs: /**Notes:**

By-pass of the process and switch over to the use of the ordinary water supply and sewer system is possible.

Greywater treatment by constructed wetlands in combination with TiO₂-based photo-catalytic oxidation for suburban and rural areas without sewer system.

Z. Li, H. Gulyas, M. Jahn, D. R. Gajurel and R. Otterpohl. 2003.

Water science and Technology vol. 48, n°11-12, pp: 101-106.

Scheme details:

Location: settlement Flintenbreite, Luebeck, Germany.

Monitoring between Nov. 2000 and Feb. 2001.

Source: greywater from households.

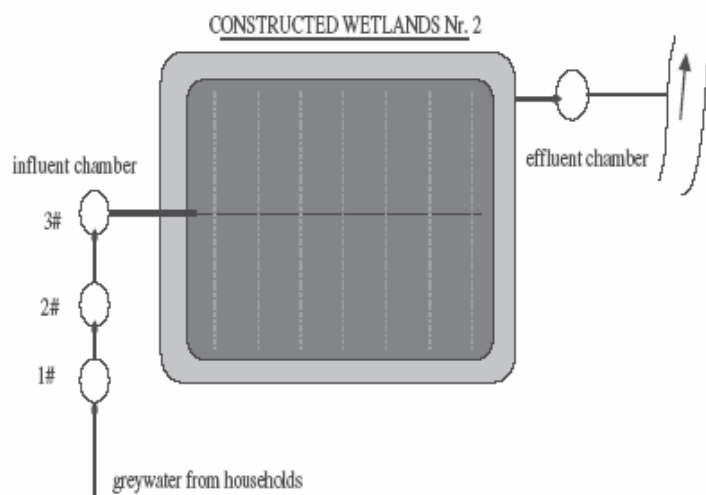

Design:

Greywater: 70L/(person*d).

Primary clarifier (3 pits).

3 vertical constructed wetlands (2m² per inhabitant) loaded intermittently.

Titanium dioxide (P25, Degussa-Huls) was added to the wetlands effluent in a stirred porcelain bowl and irradiated with UV-A light (25W/m²).

Performance:

	Influent	Wetlands Effluent
COD (mg/L)	258-354	-
TOC (mg/L)	80.2-93.8	13.4 (6)
T-P (mg/L)	5.2-9.6	5.9 (5)
T-N (mg/L)	9.7-16.6	<5 (5)
E. Coli (cfu/100mL)	7.5*10 ³ -2.6*10 ⁵	10794 (5)

TOC was reduced to 6mg/L (57% removal) with 5 mg/L of titanium dioxide and an irradiation time of 6 hours.

E. Coli was reduced from 58 to 1cfu/100mL and Total Coliforms from 36*10³ to 14cfu/100mL with 10mg/L of titanium dioxide and an irradiation time of 3 hours.

Costs: /

Notes:

One of the constructed wetland has been operated for 3 years.

Influent samples were taken in the influent chamber #3.

TiO₂-based photo-catalytic oxidation was investigated in laboratory scale experiment.

Operational performance of a submerged membrane bioreactor for reclamation of bath wastewater.

R. Liu, X. Huang, L. Chen, X. Wen and Y. Qian. 2005.

Process Biochemistry vol. 40, n°1, pp: 125-130.

Scheme details:

Location: Tsinghua University, Beijing, China.

Monitored over a 216 day period.

Source: shower bath water.

Application: car washing, land watering or toilet flushing.

Water quality standards: water reclamation standard of China.

	Standard
COD (mg/L)	≤ 50
BOD (mg/L)	≤ 10
NH ₄ ⁺ (mg/L)	≤ 20
SS (mg/L)	≤ 10
Turbidity (NTU)	≤ 10
Coliforms (cell/L)	≤ 3

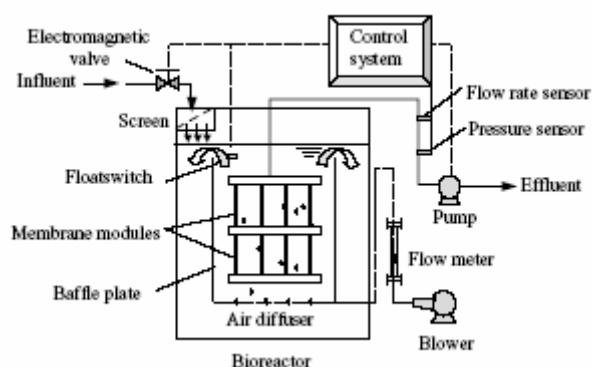

Design:

Filtration through 2 stainless steel screens of 1.2mm and 0.9 mm respectively.

Elevated tank.

Membrane Bioreactor:

Reactor (1.5m³).

8 Mitsubishi hollow fibre membrane modules (polyethylene, pore size 0.4μm, filtration area 4m² each).

Flux: 13L/(m²*h).

HRT: 3.6h.

Suction: 13 minutes on / 4 minutes off.

Performance:

	Influent	Effluent
COD (mg/L)	130-322	<40
BOD (mg/L)	99-212	<5
NH ₄ ⁺ (mg/L)	0.6-1.0	<0.5
SS (mg/L)	15-50	ND
Turbidity (NTU)	146-185	<1
Coliforms (cell/L)	-	ND

ND: not detectable.

Costs: /

Notes: /

Domestic wash water reclamation for reuse as commode water supply using a filtration – reverse osmosis technique.

J. B. Hall Jr., C. E. Batten and J. R. Wilkins. 1974

NASA Technical Note D-7600.

Scheme details:

Location: Langley research centre, Hampton, USA.

Pilot scale 12-day experiment.

Source: shower and washing machine.

Application: toilet flushing.

Water quality standards: U.S. Public Health drinking water standards.

	Standard
NH ₄ ⁺ (mg/L)	None
NO ₃ ⁻ & NO ₂ ⁻ (mg/L)	45
PO ₄ ³⁻ (mg/L)	None
TOC (mg/L)	None
Turbidity (NTU)	2
SS (mg/L)	None

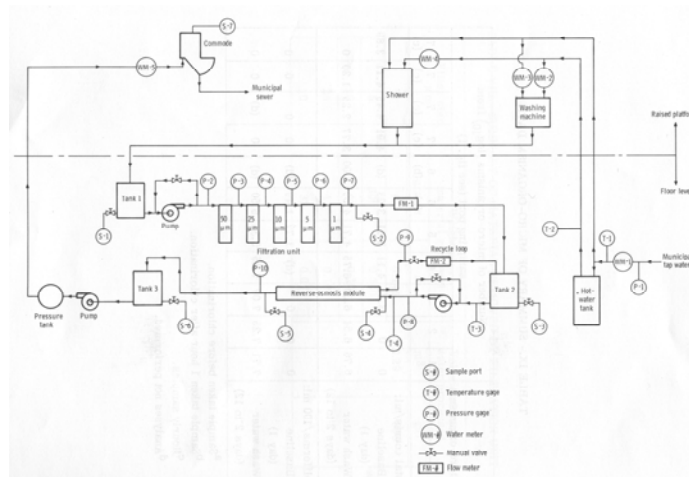

Design:

Greywater tank.

5 filters (50µm, 25µm, 10µm, 5µm, 1µm) made of bleached white cotton wound into diamond structure in a stainless steel housing.

Reverse osmosis module with asymmetric hollow fibres (aromatic polyamide polymer, inside and outside diameter were respectively 42µm and 84µm, length 0.381m).

Processed water tank.

Performance:

	Wash water	After filters	After RO
NH ₄ ⁺ (mg/L)	0.36	0.23	0.06
NO ₃ ⁻ & NO ₂ ⁻ (mg/L)	<0.2	<0.2	<0.2
PO ₄ ³⁻ (mg/L)	189.1	170.0	3.96
TOC (mg/L)	76.1	49.6	4.8
Turbidity (NTU)	30	16	0
SS (mg/L)	102	<100	<100
Coliforms (Log10 cell/100mL)	7.71	7.25	5.34

Costs: /

Notes: /

Greywater reuse for sustainable water demand management.**M. J. Bino.****Proceedings of the International Water Demand Management Conference. Amman, Jordan. May 30-June 3, 2004.****Scheme details:**

Location: Ain Al Baisa village, Tafila, Jordan.

Project : 2001-2003.

Source: kitchen, bathroom and clothes washing.

Application: gardens irrigation.

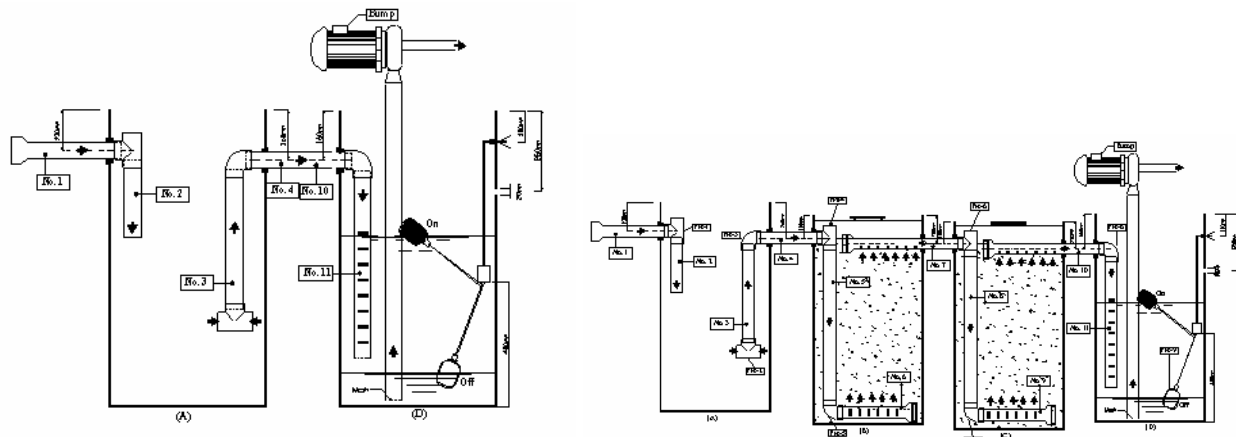
**Design:**

- 2-barrel system:

Tank 1 (160L): primary treatment chamber in which solids settle and other components such as grease and soap foam float.

Tank 2 (160L): storage tank with a floating device connected to a pump which turns on when the tank is full and deliver the treated water in the irrigation system.

- 4-barrel system:

2 tanks are added to the 2-barrel system. The tank 2 and 3 (220L each) are filled with gravel (2-3 cm) and act as anaerobic filters. (HRT: 1-2days)

- Confined trench system

2-barrel system with a dug trench (3m long, 1m wide and 1m deep) lined with an impermeable polyethylene sheet (400-500 μ m thick) and filled with gravel (2-3cm). (HRT: 2-3days)

Performance:

	2-barrel syst.	4-barrel syst.	Confined trench syst.
BOD (mg/L)	159 (6)	375 (6)	171 (3)
TSS (mg/L)	47 (6)	107 (6)	156 (3)
COD (mg/L)	-	-	204 (3)

Costs:

- 2-barrel system for a 6-person family including a drip irrigation system: 230\$US.
- 4-barrel system for a 6-person family including a drip irrigation system: 370\$US.
- Confined trench system for 12 persons including a drip irrigation system: 500\$US.

Notes:

Raw greywater BOD: 300-1200mg/L.

Application of tubular ceramic membranes for reuse of wastewater from buildings.

K.-H. Ahn, J.-H. Song and H.-Y. Cha. 1998.

Water Science and Technology vol. 38, n°4-5, pp: 373-382.

Scheme details:

Location: Lott Resort & Hotel complex, Seoul, Korea.

Bench scale experiments.

Source: greywater from hotel.

Application: toilet flushing.

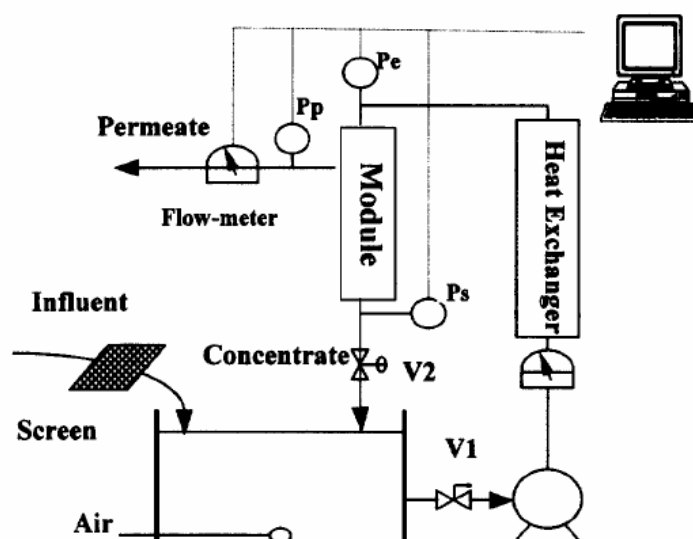
**Design:**

Membranes used were KERASEP K01-X (Rhone-Poulenc, France). Three types of membranes were used: 0.1 μ m pore size microfiltration and 15kDa and 300kDa ultrafiltrations. They were TiO₂ and ZrO₂ membranes with monolithic Al₂O₃-TiO₂ support layer. These membranes were single tubes with 7 channels, with inner diameters of 4.5mm and a total surface area of 0.08m².

Performance:

		MWCO/Pore size						
		15 kDa					300 kDa	0.1 μ m
		Crossflow velocity (m/s)		TMP (kPa)				
		1.0	2.5	4.0	227.6	366.2		
TOC	Influent	9.4	11.2	10.7	6.4	7.7	5.7	6.7
(mg/L)	Permeate	3.9	4.6	4.3	2.9	2.7	2.2	3.1
COD	Influent	48.8	83.0	74	41.0	85.9	42.2	75.4
(mg/L)	Permeate	15.6	14.3	7.7	9.7	9.7	5.6	8.5
Turbidity	Influent	6.2	18.1	151	8.9	8.9	6.9	8.2
(NTU)	Permeate	0.2	0.7	0	0	0	0.2	0

Costs: /**Notes:** /

Low strength greywater characterisation and treatment by direct membrane filtration.**G. Ramon, M. Green, R. Semiat and C. Dosoretz. 2004.****Desalination vol. 170, pp: 241-250.****Scheme details:**

Location: Haifa, Israel.

Bench scale experiments.

Source: Technion sports centre's public shower.

Application: /

Water quality standards: Standards in Israel.

	Standard
BOD (mg/L)	<10
COD (mg/L)	<100
SS (mg/L)	<10

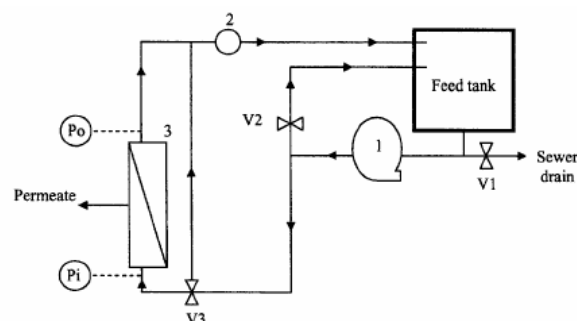
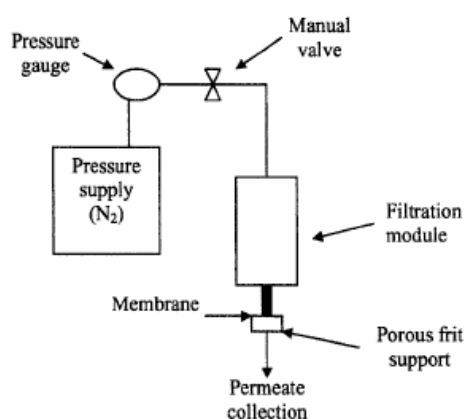
**Design:**

- Dead-end ultrafiltration module with flat sheet membrane. Three different types of membranes: polyacrylonitrile with a MWCO of 400kDa and 200kDa (Rochem UF-Systeme AG) and polyethersulfone with a MWCO of 30kDa (PM30, Millipore).
- Crossflow nanofiltration with a tubular membrane (30 cm long and 1.25cm inner diameter) of polyamide with a MWCO of ~200Da and 0.014m² surface area (AFC30, PCI).

Performance:

	Influent	Dead-end ultrafiltration permeate			Crossflow nanofiltration	
		400kDa	200kDa	30kDa	Influent	Permeate
COD (mg/L)	170±49 (19)	80.0±21.5 (5)	74.3±28.6 (5)	50.6±6.6 (3)	226	15
TSS (mg/L)	29.8±11.3 (21)	-	-	-	27.6	none
BOD (mg/L)	78±26 (13)	-	-	-	-	-
Turbidity (NTU)	23±8.5 (14)	1.4±0.4 (4)	1.0±0.5 (5)	0.8±0.2 (5)	29.5	0.6
NH ₄ ⁺ (mg/L)	1.5-3.0	-	-	-	-	-
NO ₃ ⁻ (mg/L)	0.05-1.7	-	-	-	-	-
PO ₄ ³⁻ (mg/L)	0.02-0.19	-	-	-	-	-
TOC (mg/L)	-	-	-	-	37.7	6.2

Costs: /**Notes: /**

Laundry wastewater treatment using coagulation and membrane filtration.**S. Sostar-Turk, I. Petrinic, and M. Simonc. 2005.****Resources Conservation and Recycling vol. 44, n°2, pp: 185-196.****Scheme details:**

Location: Maribor, Slovenia.

Pilot scale experiments.

Source: Laundry.

Application: /

Water quality standards: Slovenian regulation.

	Standard
Temperature (°C)	30
pH	6.5-9.0
T-N (mg/L)	10
NH ₄ -N (mg/L)	5

	Standard
T-P (mg/L)	1.0
BOD (mg/L)	30
COD (mg/L)	200
SS (mg/L)	80

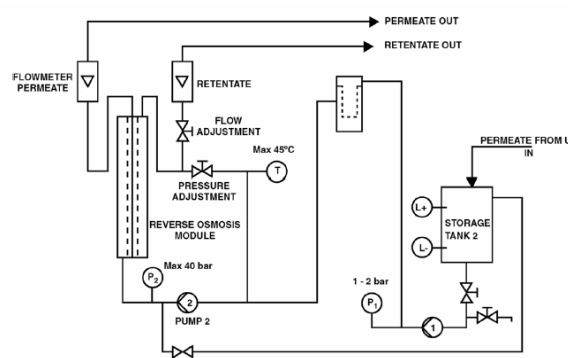
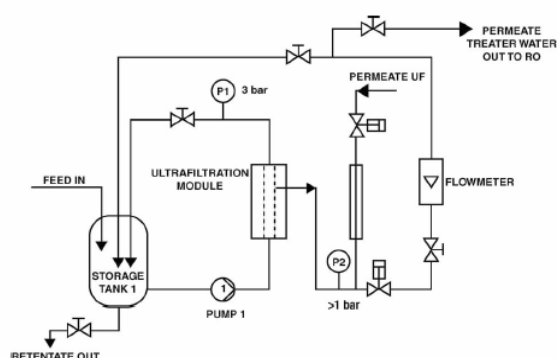
**Design:**

- Ultrafiltration pilot: The raw water is pumped from the storage tank through the UF tubular module (diameter: 25.4mm, length: 900mm, multi-channel membrane with an active surface made of Al₂O₃, TiO₂ and ZrO₂, surface area: 0.13m² and molecular cut-off: 20-400kDa). Permeate flow velocity: 15-20m/s
- Reverse osmosis pilot: The raw water is pumped from the storage tank through a pre-filtration unit and then the reverse osmosis module under 20-30bar (membrane: polyethersulfone, surface area: 1.5m²)

Performance:

	Influent	Ultrafiltration permeate	Reverse osmosis permeate
Temperature (°C)	62.0	53.8	27.8
pH	9.65	8.30	7.62
SS (mg/L)	35	18	8
BOD (mg/L)	195	86	1.5
COD (mg/L)	280	130	3
T-N (mg/L)	2.75	0.03	0.03
NH ₄ -N (mg/L)	2.45	0.03	0.03
T-P (mg/L)	9.92	0.46	0.14

Costs:

	Cost (€/m ³)
Cost of plant	0.63
Energy	0.4
Chemicals	0.16
Membrane replacement	0.08
Maintenance	0.08

Notes: /

On-site greywater treatment and reuse in multi-storey buildings.**E. Friedler, R. Kovalio, N. I. Galil.****Proceedings of the 1st International Conference on Onsite Wastewater Treatment & Recycling. Fremantle, Western Australia. February 11-13, 2004.****Scheme details:**

Location: 7 flats (married students, some with young children) within Technion campus, Haifa, Israel.

Pilot scale experiments.

Source: baths, showers and hand basins.

Application: toilet flushing

Water quality standards: urban effluent reuse regulations, Israeli Ministry of Health (2003).

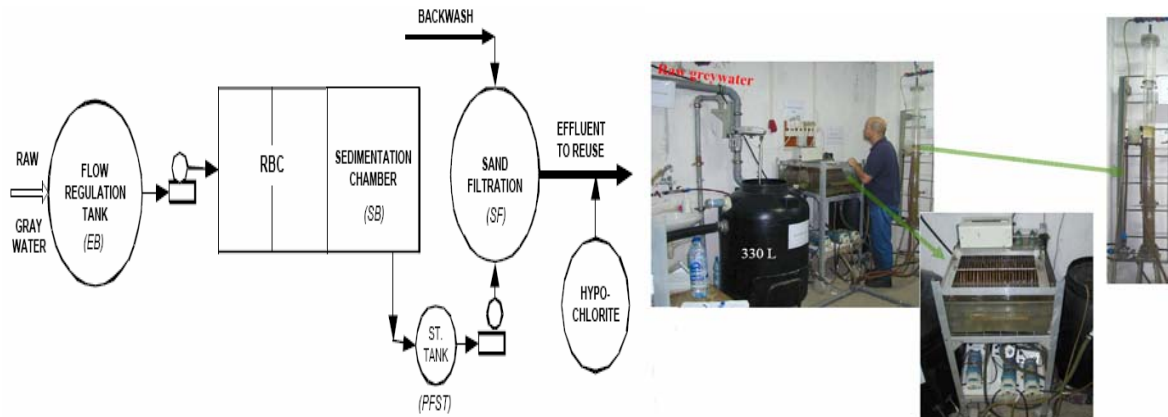
**Design:**

- Fine screen (1mm square mesh)
- Equalisation tank (330L), HRT: 10 hours
- Rotating biological contactor (RBC):
 - 2 reactors of 15L each, HRT: 4 hours
 - 0.22m diameter discs (surface area 1m²), rotation speed: 13rpm
 - Flow rate: 7.5L/hrs
- Sedimentation tank (7.5L), HRT: 1 hour
- Pre-filtration storage tank, HRT: 2.2 hours
- Sand filtration:
 - Gravity filter (10 cm diameter, 70 cm media height)
 - Quartz sand size 0 (porosity 0.36)
 - 5 cm of gravel (2.2 mm diameter)
 - Operated intermittently 11 times a day for 15 minutes
 - Flow rate 65 L/hrs (hydraulic load: 8.33m/hrs)
 - Backwashed once a week
- Disinfection: hypochlorite (0.2-0.25%) dosed for 1mg/L chlorine residual after 30 minutes

Performance:

	Turbidity (NTU)	TSS (mg/L)	BOD (mg/L)	COD (mg/L)	Faecal coliforms (cfu/100mL)
Influent	33 ± 23 (31)	43.0 ± 25.1 (30)	59 ± 30 (17)	158 ± 60 (33)	5.6*10 ⁵ ± 6.5*10 ⁵ (16)
Effluent	0.6 ± 0.4 (24)	7.9 ± 4.9 (23)	2 ± 2 (11)	40 ± 14 (20)	1 ± 1 (10)

Costs: /**Notes: /**

Conservation Co-op Residential Water Reclamation Project.
Canada Mortgage and Housing Corporation. 2002.
www.cmhc.ca

Scheme details:

Location: 8 apartments in a 4 storey building in Ottawa, Canada.

Commissioned: August 1999.

Source: showers and baths.

Application: toilet flushing.

Water quality standards:

TSS < 30 mg/L.

Turbidity <20 NTU

E. Coli not detectable

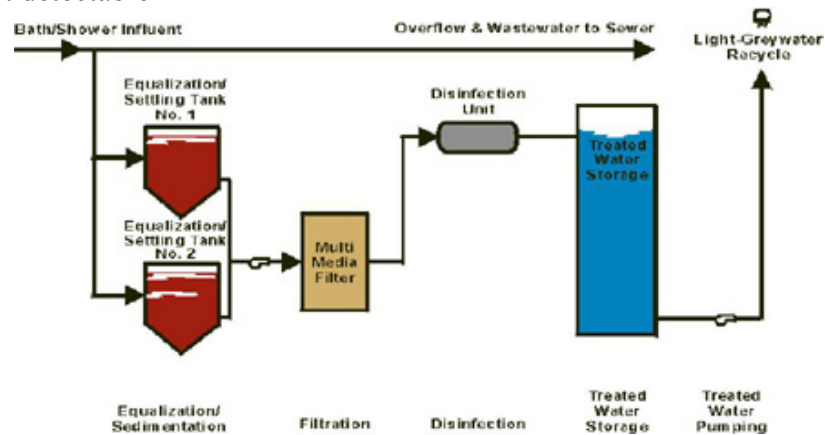

Design:

- Screening (1 mm mesh)
- 2 sedimentation tanks (removal of the floating particles and settled solids), HRT: 6-12 hours
- Multi-media (anthracite, fine sand, garnet and limestone) pressure filter
- Ozonation
- Treated water tank (600L)

Performance:

	TSS (mg/L)	Turbidity (NTU)	BOD (mg/L)	E. Coli (cfu/100mL)
Raw water	67	82	130	8870
Treated water	21	26	-	8

Costs: /

Notes:

Estimated use for toilet flushing: 640L/day

Greywater available: 1300L/day

Reuse plant designed to treat 1000L/day

The system was stopped in 2001 because of odours problems, scum and accidental ozone release

Performance of pilot scale greywater reuse RBC/MBR based systems.

E. Friedler.

Proceedings of the Watersave, one day event on water demand management, London, UK. June 14, 2005.

Scheme details:

Location: 7 flats (married students, some with young children) within Technion campus, Haifa, Israel.

Pilot scale experiments.

Source: baths, showers and hand basins.

Application: toilet flushing

Water quality standards: urban effluent reuse regulations, Israeli Ministry of Health (2003).

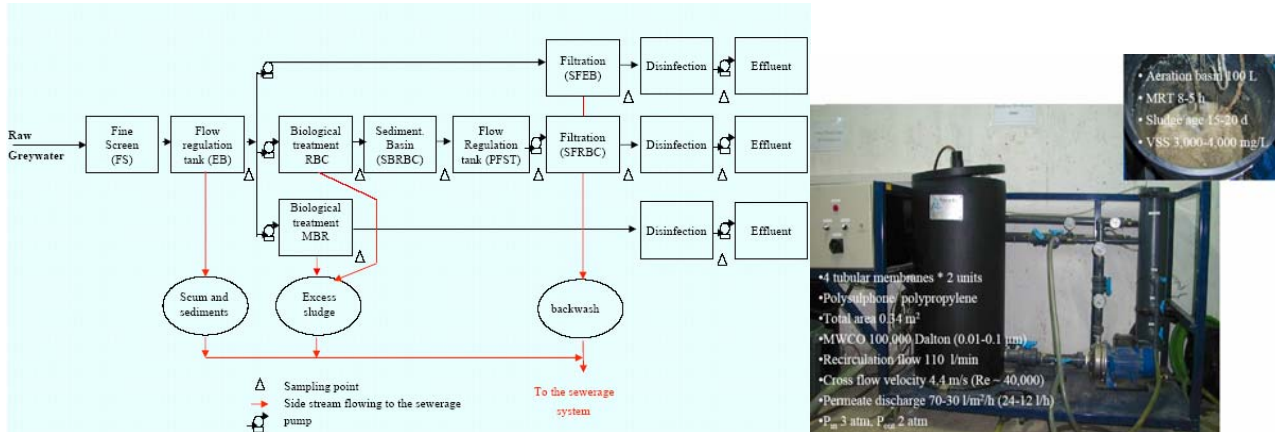

Design:

- Fine screen (1mm square mesh)
- Equalisation tank (330L), HRT: 10 hours
- Side Stream Membrane Bioreactor:
 - 2 units of 4 tubular membranes (polysulphone-polypropylene, surface area: 0.34m², MWCO: 100 kDa (0.01-0.1μm))
 - Recirculation flow: 110 L/min
 - Reactor 100 L
 - LMH: 30-70, HRT: 5-8 hrs, SRT: 15-20 days, VSS: 3000-4000 mg/L
- Disinfection: hypochlorite (0.2-0.25%) dosed for 1mg/L chlorine residual after 30 minutes

Performance:

	Influent	Effluent
TKN (mg/L)	9.3 ± 3.4 (18)	1.8 ± 2.8 (18)
NH ₄ -N (mg/L)	3.6 ± 2.8 (19)	1.0 ± 1.6 (19)
NO ₃ -N (mg/L)	0.02	0.4
NO ₂ -N (mg/L)	0.1	0.35
TP (mg/L)	4.5 ± 1.9 (19)	1.3 ± 1.0 (29)
Turbidity (NTU)	80 ± 47 (18)	0.23 ± 0.10 (20)
TSS (mg/L)	103 ± 64 (18)	13 ± 8.4 (20)
BOD (mg/L)	95 ± 29 (8)	1.1 ± 1.7 (9)
COD (mg/L)	206 ± 70 (19)	47 ± 30 (17)
Faecal coliforms (cfu/100mL)	3.4*10 ⁵ ± 4.2*10 ⁵	27 ± 56

Costs: /

Notes: /

Case Studies of Greywater Recycling in Western Australia.**R. Mars.****Proceedings of the 1st International Conference on Onsite Wastewater Treatment & Recycling. Fremantle, Western Australia. February 11-13, 2004.****Scheme details:**

Location: House in Mt Hawthorn, Western Australia

Source: laundry water

Application: garden watering

Water quality standards: “Code of Practice for the Reuse of Greywater in Western Australia” by the Department of Health (2003):

- Manual bucketing (no treatment). Greywater can be collected and then placed on garden beds.
- Primary treatment. Greywater is first passed through either a sedimentation tank or a filter before it is placed into a subsurface trench system.
- Secondary treatment. Greywater is treated to a high standard by passing it through an aerated treatment system, and then allowed to be placed onto garden beds by sprays or drippers

**Design:**

- 200 µm needlebelt fibre bag (capacity 6L)
- Safety overflow device
- 2 6m-long subsurface trenches
- Flow rate: 152L/day

Performance:

	Influent	Effluent
Nitrate (mg/L)	3.8	2.5
Phosphate (mg/L)	0.09	0.06
SS (mg/L)	155	76
pH	7.8	7.6

Costs: /**Notes: /**

Case Studies of Greywater Recycling in Western Australia.

R. Mars.

Proceedings of the 1st International Conference on Onsite Wastewater Treatment & Recycling. Fremantle, Western Australia. February 11-13, 2004.

Scheme details:

Location: House in Bassendean, Perth, Australia

Source: laundry and bathroom waters

Application: garden watering

Water quality standards: “Code of Practice for the Reuse of Greywater in Western Australia” by the Department of Health (2003):

- Manual bucketing (no treatment). Greywater can be collected and then placed on garden beds.
- Primary treatment. Greywater is first passed through either a sedimentation tank or a filter before it is placed into a subsurface trench system.
- Secondary treatment. Greywater is treated to a high standard by passing it through an aerated treatment system, and then allowed to be placed onto garden beds by sprays or drippers



Design:

- Sedimentation tank (1000L)
- Safety overflow device
- 2 10m-long subsurface trenches
- Flow rate: 400L/day

Performance:

	Influent	Effluent
Nitrate (mg/L)	9.1	3.1
Phosphate (mg/L)	0.61	0.15
SS (mg/L)	405	100
pH	9.1	8.0

Costs: /

Notes: /

Case Studies of Greywater Recycling in Western Australia.

R. Mars.

Proceedings of the 1st International Conference on Onsite Wastewater Treatment & Recycling. Fremantle, Western Australia. February 11-13, 2004.

Scheme details:

Location: House in Nedlands, Western Australia

Source: laundry and bathroom waters

Application: garden watering

Water quality standards: “Code of Practice for the Reuse of Greywater in Western Australia” by the Department of Health (2003):

- Manual bucketing (no treatment). Greywater can be collected and then placed on garden beds.
- Primary treatment. Greywater is first passed through either a sedimentation tank or a filter before it is placed into a subsurface trench system.
- Secondary treatment. Greywater is treated to a high standard by passing it through an aerated treatment system, and then allowed to be placed onto garden beds by sprays or drippers



Design:

- 2 sedimentation tanks (350L each)

- The water is then pumped from a pump chamber made of 3 200L tanks through drippers onto the garden beds

Performance:

	Influent	Pump tank	Dripper irrigation
Nitrate (mg/L)	3.3	3.0	1.7
Phosphate (mg/L)	1.93	1.63	0.66
SS (mg/L)	310	195	20
pH	10.3	8.9	8.2

Costs: /

Notes: /

Subsurface flow reedbeds using alternative media for the treatment of domestic greywater in Monteverde, Costa Rica, Central America.

S. Dallas and G. Ho.

Proceedings of the 1st International Conference on Onsite Wastewater Treatment & Recycling, Fremantle, Western Australia. February 11-13, 2004.

Scheme details:

Location: Monteverde Institute, Costa Rica.

Commissioned: November 2002.

Source: mixed greywater.

Application: /

Water quality standards: Costa Rican standards

(faecal coliforms < 1000 cfu/100mL and

BOD < 40 mg/L)



Design:

- 12 plastic-lined trenches (1.5 m long, 0.25 m wide and 0.2 m deep) with an average volume of 58.23 L and a surface area of 0.375 m².

- 2 types of media: local crushed rock (20 mm, porosity: 40%) and segments of PET plastic drinking water bottles (100-150 mm, porosity: 94%).

- The trenches with PET were topped with a layer of newspaper (4-6 sheets) and a thin layer of crushed rock (20-25 mm).

- 6 of the trenches were planted with *Coix Lacryma-jobi*.

- The greywater was added to each trench twice a day to a total of either 5 L/day or 10 L/day.

Trench	Media	Average volume (L)	Retention time at 5L/day (h)	Retention time at 10L/day (h)
1, 2, 9	PET + plants	59.53	9.2	4.6
6, 8, 10	PET – no plants	58.11	8.9	4.5
4, 7, 12	Crushed rock + plants	57.95	6.0	3.0
3, 5, 11	Crushed rock – no plants	57.32	6.1	3.0

Performance:

	Season	Flow rate (L/day)	BOD (mg/L)	Faecal Coliforms (cfu/100mL)	PO ₄ -P (mg/L)	NO ₃ -N (mg/L)	Turbidity (NTU)
Raw			254	7.7*10 ⁷	9.6	<1	103
PET + plants	dry	5	3.5	2175	-	-	-
		10	12.7	2050	-	-	-
	wet	5	16.5	1467	-	-	-
		10	25.5	-	-	-	-
PET	dry	5	16.3	11.0*10 ⁵	-	-	-
		10	18.4	10.5*10 ⁵	-	-	-
	wet	5	19.4	2.7*10 ⁵	-	-	-
		10	31.0	-	-	-	-
Crushed rock + plants	dry	5	7.0	2422	-	-	-
		10	17.6	2.6*10 ⁵	-	-	-
	wet	5	20.8	12724	-	-	-
		10	26.3	-	-	-	-
Crushed rock	dry	5	9.3	2.9*10 ⁵	-	-	-
		10	19.1	1.3*10 ⁵	-	-	-
	wet	5	18.8	22250	-	-	-
		10	28.3	-	-	-	-

Costs:/ Notes:/

Phyto-treatment of greywater with yellow water addition from an aesthetic approach.**M. Borin, R. Cossu, M. C. Lavagnolo and M. Gandini.****Proceedings of the 1st International Conference on Onsite Wastewater Treatment & Recycling. Fremantle, Western Australia. February 11-13, 2004.****Scheme details:**

Location: IMAGE department, University of Padua, Italy.

Commissioned: November 2002.

Source: washbasin and urine.

Application: /

Water quality standards:

	COD (mg/L)	BOD (mg/L)	NH ₃ (mg/L)	NO ₂ (mg/L)	NO ₃ (mg/L)
Limit	120	30	15	0.6	20

**Design:**

- 2 subsurface horizontal flow beds (surface area: 4.3 m², slope of 1.5% and average depth: 0.6 m)
- Media: sand and gravel (porosity: 25%)
- One planted with *Phragmites australis* and the second with ornamental plants (*alisma*, *iris*, *typha*, *menthe*, *canna*, *thalia*, *lysimachia*, *lytrum*, *pontederia*, and *preselia*)
- HRT: 7 days, flow rate: 90 L/day
- Urine was added to the greywater at either 0.25% or 1% in volume

Performance:

	Influent	Effluent (ornamental)	Effluent (<i>Phragmites</i>)
TKN (mg/L)	16.9	7.71	6.89
NH ₃ (mg/L)	11.9	4.25	3.84
NO ₂ (mg/L)	0.1	0.01	0.01
NO ₃ (mg/L)	4.0	0.16	0.20
TP (mg/L)	0.8	0.28	0.26
BOD (mg/L)	42.4	25.8	26.6
COD (mg/L)	151.1	51.2	50.5
pH	7.17	6.90	6.84
TSS (mg/L)	25	20	30

Costs: /**Notes: /**

The performance of a greywater system at the healthy home in south east queensland – three years of data.

T. Gardner and G. Millar.

Proceedings of the Onsite '03 Conference. Armidale, Australia. September 30-October 2, 2003.

Scheme details:

Location: Healthy Home, Gold Coast, Queensland, Australia.

Commissioned: April 2000 to November 2002.

Source: bathroom and laundry.

Application: external and toilet flushing uses.

Water quality standards: DNR On-Site Guidelines 1999

	BOD (mg/L)	SS (mg/L)	Turbidity (NTU)	Faecal Coliform (cfu/100mL)
Limit	≤ 10	≤ 10	≤ 2	10

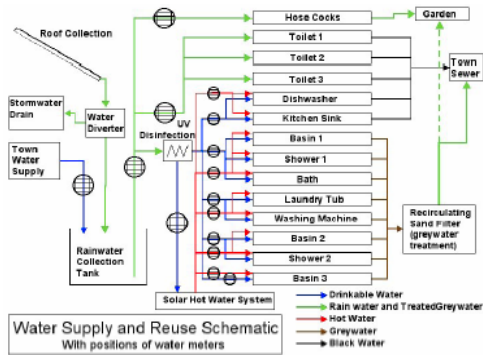

Design:

Re-circulating sand filter contained in a 6 m³ concrete tank.

Tank is divided in:

- 1.8 m³ septic tank
- 2 pump wells
- 0.9 m³ sand filter

The flow controller doses the sand filter up to 96 times per day to maximise contact between the attached media growth and the percolating water.

An 80 Watt UV disinfection system was to the 2nd pump well in November 2000.

Performance:

	Influent (n=27)	Effluent (n=32)
BOD (mg/L)	97 ± 78	6 ± 12
SS (mg/L)	48 ± 91	3 ± 11
Turbidity (NTU)	-	1 ± 5
Faecal Coliforms (cfu/100mL)	100 ± 45954	1 ± 54
Total Coliforms (cfu/100mL)	180000 ± 193800	9 ± 2990
TN (mg/L)	6.6 ± 4.1	3.0 ± 1.4
TP (mg/L)	0.7 ± 3.2	0.7 ± 1.9

Costs:

Greywater system capital cost	\$5500
O&M costs	\$230/year
Water saving (82 m ³ @ \$1.1/m ³)	\$90.2
Payback period	NEVER!!!

Notes: /

Technologies for greywater recycling in buildings.

A. Laine. 2001.

PhD thesis, Cranfield University.

Scheme details:

Location: Pilot plant in the STW at Cranfield University, UK.

Commissioned: 1998 - 2001.

Source: synthetic greywater.

Application: /

Water quality standards: /

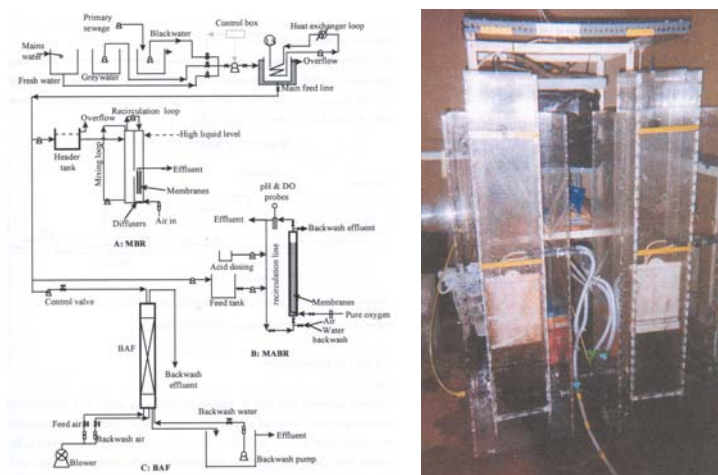

Design:

A 100-L PVC constant head device was used to feed the MBR.

Submerged membrane bioreactor (MBR):

- 2 perspex chambers (35L each) divided into de-nitrification and nitrification units.
- 2 flat sheet Kubota membranes (surface: 0.24 m², polysulphone, pore size: 0.4 μm) placed in each nitrification tank.
- Aeration at the bottom the tanks.

Performance:

	Influent	Effluent
BOD (mg/L)	41 ± 30	1 ± 1
COD (mg/L)	128 ± 89	7 ± 6
TN (mg/L)	6 ± 3	6 ± 4
NH ₃ -N (mg/L)	0.4 ± 0.4	0.5 ± 0.8
NO ₃ -N (mg/L)	2.2 ± 1.9	5.2 ± 2.9
TP (mg/L)	1.7 ± 1.4	2.5 ± 1.5
SS (mg/L)	52 ± 58	4 ± 4
Turbidity (NTU)	-	0.3 ± 0.3
Total Coliforms (cfu/100mL)	1.47*10 ⁶ ± 4.34*10 ⁶	2 ± 5
E. Coli (cfu/100mL)	4.22*10 ³ ± 4.85*10 ³	1 ± 0
Faecal Streptococci (cfu/100mL)	1.16*10 ³ ± 2.29*10 ³	60 ± 378

Costs: /

Notes: /

Technologies for greywater recycling in buildings.**A. Laine. 2001.****PhD thesis, Cranfield University.****Scheme details:**

Location: Pilot plant in the STW at Cranfield University, UK.

Commissioned: 1998 - 2001.

Source: synthetic greywater.

Application: /

Water quality standards: /

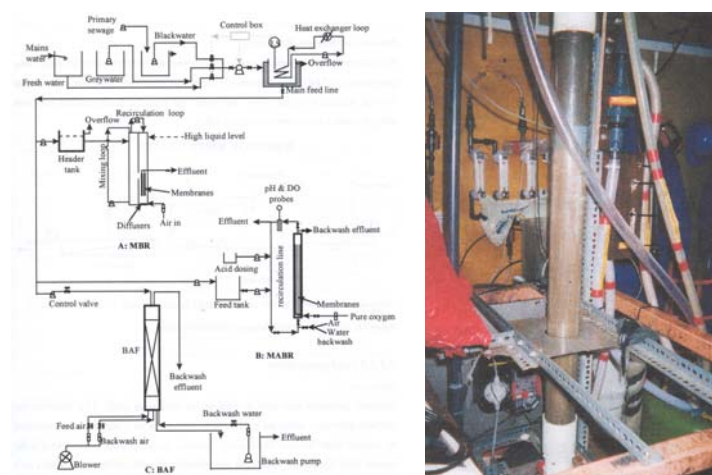
**Design:**

Membrane Aeration Bioreactor (MABR):

- The feed was pump in the perspex column (7.3 L).
- A hollow fibre bundle (surface: 3.42 m², urethane/polyethylene composite, pore size: 0.04 µm) was placed in the reactor
- The reactor was fed with pure oxygen at a rate of 0.00973 L.min⁻¹.

Performance:

	Influent	Effluent
BOD (mg/L)	41 ± 30	9 ± 9
COD (mg/L)	128 ± 89	17 ± 34
TN (mg/L)	6 ± 3	6 ± 1
NH ₃ -N (mg/L)	0.4 ± 0.4	0.5 ± 0.8
NO ₃ -N (mg/L)	2.2 ± 1.9	3.9 ± 1.5
TP (mg/L)	1.7 ± 1.4	0.5 ± 0.3
SS (mg/L)	52 ± 58	13 ± 13
Turbidity (NTU)	-	6.6 ± 6.5
Total Coliforms (cfu/100mL)	1.47*10 ⁶ ± 4.34*10 ⁶	1.96*10 ⁴ ± 6.18*10 ⁴
E. Coli (cfu/100mL)	4.22*10 ³ ± 4.85*10 ³	2.01*10 ³ ± 4.13*10 ³
Faecal Streptococci (cfu/100mL)	1.16*10 ³ ± 2.29*10 ³	1.65*10 ³ ± 2.59*10 ³

Costs: /**Notes: /**

Technologies for greywater recycling in buildings.

A. Laine. 2001.

PhD thesis, Cranfield University.

Scheme details:

Location: Pilot plant in the STW at Cranfield University, UK.

Commissioned: 1998 - 2001.

Source: synthetic greywater.

Application: /

Water quality standards: /

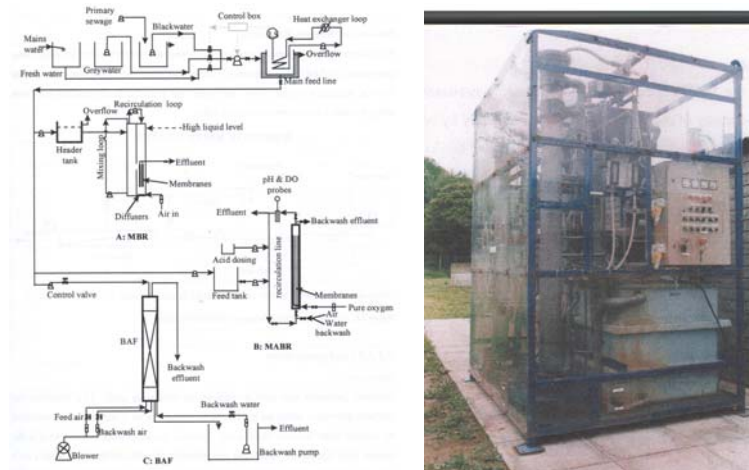

Design:

Biological Aerated Filter (BAF):

- 1.64 m deep of a 0.165 m-diameter column was filled with a 3-4mm plastic media on which a biofilm was developed.
- The feed was pumped in the column at counter current to the air flow ($15 \text{ L}\cdot\text{min}^{-1}$).
- The effluent was collected in a 1.5 m^3 tank for backwashing purpose.

Performance:

	Influent	Effluent
BOD (mg/L)	41 ± 30	4 ± 4
COD (mg/L)	128 ± 89	13 ± 13
TN (mg/L)	6 ± 3	3 ± 2
NH ₃ -N (mg/L)	0.4 ± 0.4	0.7 ± 0.8
NO ₃ -N (mg/L)	2.2 ± 1.9	1.6 ± 1.6
TP (mg/L)	1.7 ± 1.4	0.3 ± 0.2
SS (mg/L)	52 ± 58	6 ± 6
Turbidity (NTU)	-	3.2 ± 9.0
Total Coliforms (cfu/100mL)	$1.47 \cdot 10^6 \pm 4.34 \cdot 10^6$	$2.04 \cdot 10^4 \pm 5.47 \cdot 10^4$
E. Coli (cfu/100mL)	$4.22 \cdot 10^3 \pm 4.85 \cdot 10^3$	$2.59 \cdot 10^3 \pm 4.41 \cdot 10^3$
Faecal Streptococci (cfu/100mL)	$1.16 \cdot 10^3 \pm 2.29 \cdot 10^3$	$7.81.65 \cdot 10^2 \pm 1.80 \cdot 10^3$

Costs: /

Notes: /

Technologies for greywater recycling in buildings.**A. Laine. 2001.****PhD thesis, Cranfield University.****Scheme details:**

Location: Pilot plant in the STW at Cranfield University, UK.

Commissioned: 1998 - 2001.

Source: synthetic greywater.

Application: /

Water quality standards: /

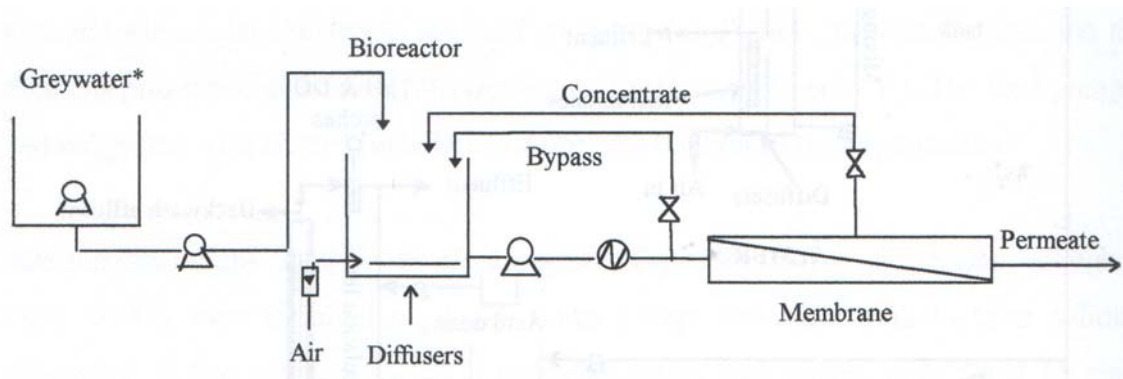
**Design:**

Side-stream membrane bioreactor (MBR):

- The feed was pumped from the greywater tank to the reactor (380 L).
- The mixed liquor was then recirculated to the reactor in a loop containing a FP100 (PCI Membrane Systems) tubular ultrafiltration membrane (12.5 mm diameter, 1.2 m long)
- Aeration was supplied at the bottom the tank.

Performance:

	Influent	Effluent
BOD (mg/L)	181 ± 58	1 ± 1
COD (mg/L)	273 ± 57	2 ± 3
SS (mg/L)	58 ± 16	4 ± 4
Turbidity (NTU)	-	0.9 ± 1.4
Total Coliforms (cfu/100mL)	$3.00 \cdot 10^4 \pm 3.35 \cdot 10^4$	1.1 ± 0.4
E. Coli (cfu/100mL)	$2.28 \cdot 10^2 \pm 3.08 \cdot 10^2$	1 ± 0

Costs: /**Notes: /**

Long term performance of the sand-plant-filter Schattweid (Switzerland).

A. Schonborn, B. Züst, and E. Underwood. 1997.

Water Science and Technology vol. 35, n°5, pp: 307-314

Scheme details:

Location: The Centre for Applied Ecology, Schattweid, Switzerland.

Commissioned: 1985 (data from 1990-1995)

Source: greywater and urine.

Application: infiltration.

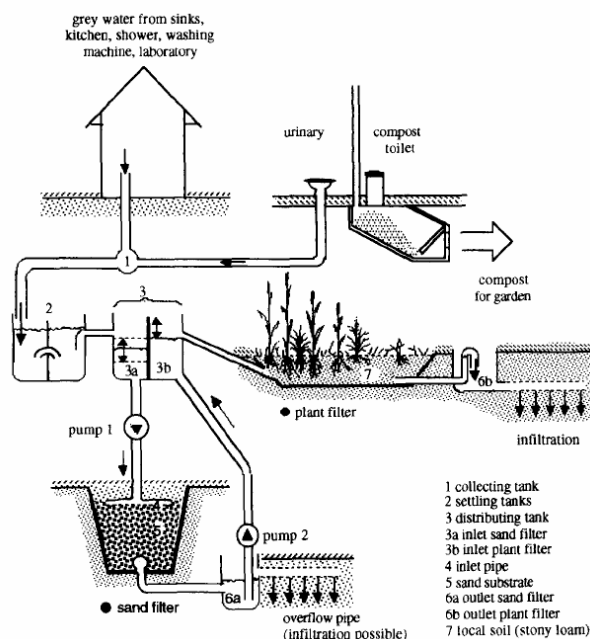
**Design:**

- Greywater and urine were collected in a 2-chambered settling tank.
- Vertical flow underground sand filter (12 m², 6 m³, 1-3 mm sand, average loading rate 33 mm/day).
- Horizontal flow constructed wetland (26 m², 13 m³, sandy, stony loam, average loading rate 15 mm/day).

Performance:

	Sand filter in	Sand filter out	Plant filter out
COD (mg/L)	311.3 (n=103)	30.8 (n=75)	26.7 (n=78)
BOD (mg/L)	129.5 (n=21)	-	5.4 (n=21)
NH ₄ -N (mg/L)	89.8 (n=103)	10.9 (n=75)	6.3 (n=98)
NO ₃ -N (mg/L)	3.0 (n=83)	50.7 (n=75)	12.7 (n=78)
Total P (mg/L)	8.5 (n=81)	3.1 (n=75)	0.8 (n=98)

Costs: /**Notes:**

- 20-30 hours of maintenance per year.
- Average population equivalents (p.e.) between 1990 and 1995: 5.1.
- Average wastewater flow: 145.3 m³/year.
- Water consumption per p.e.: 78.3 L/day

Experience with dry sanitation and greywater treatment in the ecovillage Toarp, Sweden.**I. Fittschen and J. Niemczynowicz. 1997.****Water Science and Technology vol. 35, n^o9, pp: 161-170****Scheme details:**

Location: Ecovillage Toarp (100 people, 24 of which were children), Sweden.

Commissioned: 1992 (study between May and September 1995)

Source: greywater.

Application: irrigation.

Design:

- 3-chamber sedimentation tank (5.6 m³, average HRT: 2 hours)
- Horizontal flow reed bed (Root-zone) (600 m², 0.6 m deep, plants: *Phragmites communis*, HRT: 4 days)
- Vertical flow sand filter (300 m², 0.8 m deep, HRT: 2-4 hours)
- Artificial pond (130 m³, 1.0 m deep)

Performance:

	Before root zone (n=8)	After root zone (n=8)	After sand filter (n=3)	Pond (n=3)
COD (mg/L)	361 ± 8.0	46.4 ± 8.0	43.3 ± 15.0	56.3 ± 2.1
BOD7 (mg/L)	164.6 ± 29.9	<5	<5	<5
Total N (mg/L)	18.1 ± 4.4	7.4 ± 3.4	1.3 ± 1.2	<0.43
Total P (mg/L)	3.9 ± 0.6	1.4 ± 0.5	0.79 ± 0.14	0.23 ± 0.08
Total coliforms (cfu/100mL)	<3.3*10 ⁶	<33000	<20	-

Costs: /**Notes:**

- Consumption: 210 L per capita per day.
- Greywater production: 110 L per capita per day.
- Average treated greywater: 10.7 m³/day.
- Because the system was used at a quarter of the design flow rate, the actual HRT in the Root-zone was about 14 days.

Pilot-scale SBR and MF operation for the removal of organic and nitrogen compounds from greywater.

H.-S. Shin, S.-M. Lee, I.-S. Seo, G.-O. Kim, K.-H. Lim and J.-S. Song. 1998.

Water Science and Technology vol. 38, n°6, pp: 79-88

Scheme details:

Location: Office building, Korea

Commissioned: /

Source: greywater

Application: /

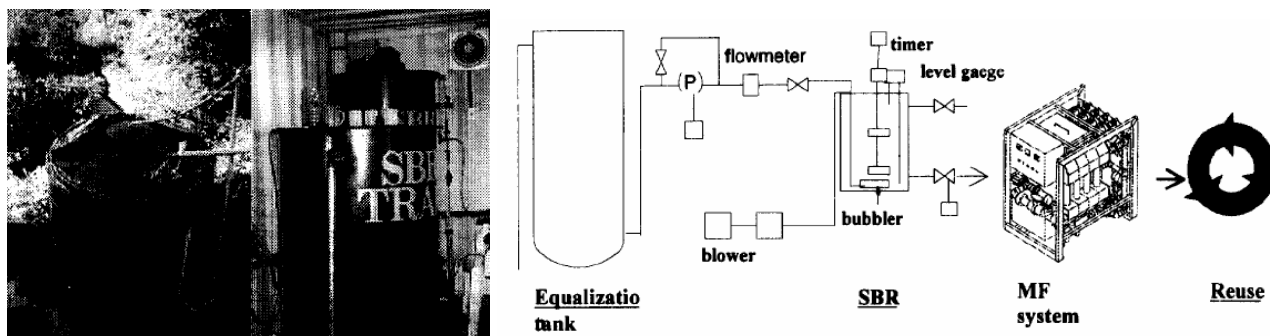

Design:

- Equalization tank (2.5 m³).
- Sequencing Batch Reactor (SBR): circular steel box (1000 L), average MLSS: 3579 mg/L
- Feeding, mixing and aeration were controlled by timers, level sensors and solenoid valves. (1 hour feeding and mixing, 60/60 minutes aeration on/off for 9 hours, 1 hour settling, ½ hour decanting, HRT: 12 hours)
- MF hollow fibre module (4 membranes unit with a capacity of 20 m³/day, 0.2 µm pore size)

Performance:

	Greywater	Effluent
COD (mg/L)	79.0 ± 38.0 (n=79)	30
BOD (mg/L)	5	5
NH ₃ (mg/L)	9.0 ± 5.5 (n=79)	< 1
TKN (mg/L)	29.0 ± 11.0 (n=21)	-
Phosphorus (mg/L)	1.7 ± 1.0 (n=21)	-
SS (mg/L)	185	-

Costs: /

Notes:

Biological aerated filters and membranes for greywater treatment.**R. Birks. 1998.****MSc thesis, Cranfield University.****Scheme details:**

Location: Pilot in the Manor Farm STW, UK.

Commissioned: 1998.

Source: synthetic and real greywater (handbasin).

Application: toilet flushing

Water quality standards: /

**Design:**

Biological Aerated Filter (BAF):

- 2 down-flow columns (2 m high, 0.15 m diameter, and total bed volume 0.036 m³).
- Media: Lytag pulverised fuel ash (mean geometric size 2.36-4.75 mm, density 1.9 kg/m³, and voidage without biomass 50%).
- The BAF was tested over 3 different hydraulic loading rates (HLR: 1.0, 0.7 and 0.3 m/h).

Performance:

	Synthetic greywater	Effluent			Greywater	Effluent	
		HLR: 1.0 m/h	HLR: 0.7 m/h	HLR: 0.3 m/h		HLR: 0.7 m/h	HLR: 0.4 m/h
BOD (mg/L)	59	15	14	8	131	51	5
COD (mg/L)	153	117	116	53	363	127	80
TOC (mg/L)	34	24	19	15	-	-	-
NH ₄ -N (mg/L)	<0.05	-	-	-	-	-	-
TKN (mg/L)	3.8	-	-	-	-	-	-
TP (mg/L)	<0.2	-	-	-	-	-	-
SS (mg/L)	18	11	9	6	109	7	8

Costs: /**Notes: /**

Biological aerated filters and membranes for greywater treatment.**R. Birks. 1998.****MSc thesis, Cranfield University.****Scheme details:**

Location: Pilot in the Manor Farm STW, UK.

Commissioned: 1998.

Source: synthetic and real greywater (handbasin).

Application: toilet flushing

Water quality standards: /

**Design:**

Membrane tester:

- 3 ultra-filtration membranes FP 200 (polyvinylidene fluoride, MWCO: 200000 Daltons), EM 006 (modified polyethersulphone, MWCO: 6000 Daltons) and ES 404 (polyethersulphone, MWCO: 4000 Daltons) were tested with both synthetic and real greywaters.
- 1 nano-filtration membrane AFC 30 (polyamide film, 75% CaCl₂ retention) and 2 reverse osmosis membranes AFC 80 (polyamide film, 80% NaCl retention) and CDA 16 (cellulose acetate, 90% NaCl retention) were then tested with synthetic greywater.

Performance:

		BOD (mg/L)	COD (mg/L)	SS (mg/L)
Synthetic greywater		49	292	6
	FP 200	31	168	-
Effluent	EM 006	31	179	-
	ES 404	29	134	-
Synthetic greywater		47	214	20
	AFC 80	4	<25	-
Effluent	CDA 16	22	65	-
	AFC 30	6.4	<25	-
Greywater		274	451	-
	FP 200	63	117	-
Effluent	EM 006	38	117	-
	ES 404	58	117	-

Costs: /**Notes: /**

Application of constructed wetlands for wastewater treatment in Nepal.
R. R. Shrestha, R. Haberi, J. Laber, R. Manandhar and J. Mader. 2001.
Water Science and Technology vol. 44, n°11-12, pp: 381-386

Scheme details:

Location: Kathmandu, Nepal.

Commissioned: April 1998.

Source: bathroom, washing machine and kitchen sink.

Application: toilet flushing, gardening and cleaning.



Design:

- The greywater is first treated in a 2-chambered (500 L) settling tank.
- Then it is stored in a 200-liter feed tank is hydro-mechanically flushed in the reed bed 3 to 4 times a day.
- The vertical flow reed bed (1×6m) is filled with coarse sand and planted with common reed (*Phragmites karka*) and *Canna* sp.
- Greywater treated: 400 to 500 L per day.

Performance:

	Greywater	Effluent
COD (mg/L)	411 ± 174 (n=9)	29 ± 20 (n=9)
BOD (mg/L)	200 ± 94 (n=9)	5 ± 5 (n=7)
NH ₄ -N(mg/L)	13.3 ± 8.0 (n=7)	0.5 ± 0.6 (n=7)
PO ₄ -P (mg/L)	3.1 ± 1.4 (n=7)	2.0 ± 1.2 (n=7)
TSS (mg/L)	97.9 ± 53.4 (n=8)	2.6 ± 2 (n=8)

Costs:

- System cost: US\$ 430.
- Operating cost: negligible.

Notes: /

Pilot-scale testing membrane bio-reactor for wastewater reclamation in industrial laundry.
M. Andersen, G. H. Kristensen, M. Brynjolf, and H. Gruttner. 2001.
Water Science and Technology vol. 46, n°4-5, pp: 67-76

Scheme details:

Location: Industrial laundry, Soborg, Denmark.

Source: Laundry wastewater.

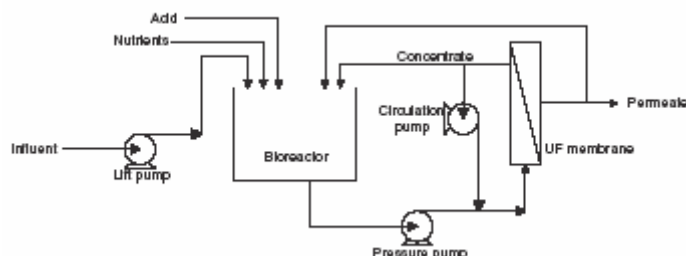

Design:

Side stream membrane bio-reactor:

- Reactor (3.5-4 m³)
- Tubular membrane (Polyacrylonitrile, 0.95 m², MWCO: 500 kDa)
- HRT: 2-2.5 d
- Flux: 70 L/(m².h)
- Addition of nutrients and pH adjusted with sulphuric acid

Performance:

	Wastewater	Effluent
COD (mg/L)	1700	50
BOD (mg/L)	645	2
NH ₄ -N(mg/L)	0.15	0.45
PO ₄ -P (mg/L)	0.88	30
TN (mg/L)	8.70	31
TP (mg/L)	34	35

Costs:

Notes:

- Laundry wastewater production: 60 m³/day, 5 day a week
- Experiments showed that a HRT of 1 d was enough to obtain satisfactory treatment

Pilot-scale electro-coagulation with bipolar aluminium electrodes for onsite domestic greywater reuse. 2005.

C.-J. Lin, S.-L. Lo, C.-Y. Kuo and C.-H. Wu.

Journal of environmental engineering, March 2005, pp: 491-495.

Scheme details:

Location: Taipei, Taiwan.

Source: greywater.

Application: toilet flushing.

Water quality standards: BOD < 10 mg.L⁻¹
E. Coli < 10 cfu/100mL

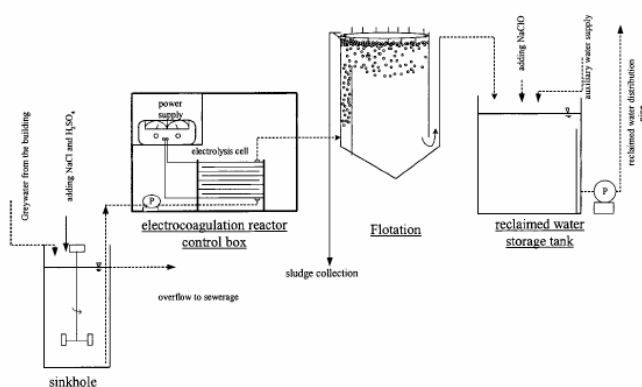

Design:

- The greywater from the building is collected in a sinkhole, in which NaCl (0.1M) and H₂SO₄ are as well dosed to adjust the conductivity to 500-600 μS/cm and the pH to 6-7 respectively.
- The greywater is then pumped into the electro-coagulation reactor (Aluminium bipolar electrodes (99 % purity), 20 horizontal flow channels, Flow velocity: 13.5 m/s Contact time 70s)
- Scum is then removed by flotation cell with gas bubbles
- Finally, the reclaimed water is store in a tank before reuse, in which NaClO was dosed for disinfection
- Footprint: 8 m²

Performance:

	Raw greywater (Avg)	Treated effluent (Avg)
Turbidity (NTU)	20.1-120.0 (43.1)	1.2-17.0 (3.6)
SS (mg/L)	15-84 (29)	4-19 (9)
BOD (mg/L)	10-41 (23)	5-16 (9)
COD (mg/L)	27-102 (55)	14-44 (22)
NH ₃ -N (mg/L)	0.145-0.148	0.006-0.007
Cl ₂ (mg/L)	-	1.2-2.1 (1.5)
E. Coli (cfu/100mL)	3800-5600 (5100)	Not detected

Costs:

Operational costs:

Electric demand (0.8 kwh/m³): 0.07 US\$/m³

Aluminium plate consumption: 0.04 US\$/m³

Chemicals: 0.02 US\$/m³

Sludge treatment: 0.06 US\$/m³

Total operational costs: 0.19 US\$/m³

Capital cost: 0.08 US\$/m³

Total unit cost: 0.27 US\$/m³

Notes: /

Membrane fouling during domestic water recycling.**B. N. Lodge. 2003.****EngD thesis, Cranfield University.****Scheme details:**

Location: Pilot plant in the STW at Cranfield University, UK.

Commissioned: 2001-2003.

Source: greywater.

Application: /

Water quality standards: /

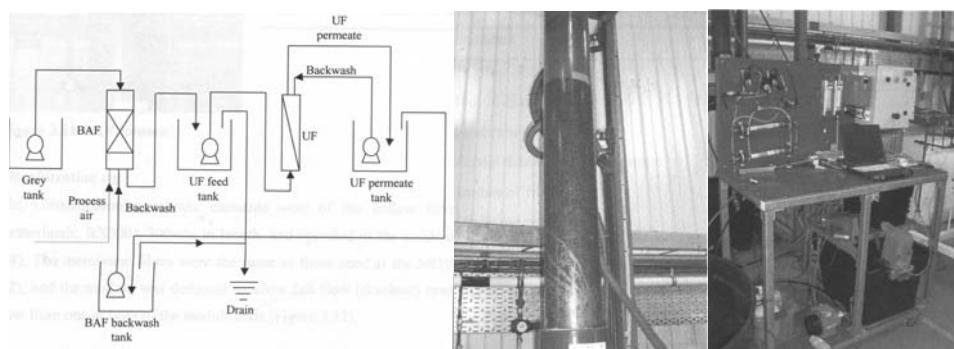
**Design:**

Biological Aerated Filter (BAF) followed by Ultra-filtration:

BAF:

- 0.165 m diameter Perspex column
- Plastic media 3-4 mm of 1m depth
- Feed flow rate: 100-150 ml/min
- Aeration flow rate: 5 L/min
- HRT: 71 min
- Organic loading rate: 1.1-2.3 kg_{COD}/(m³*day)

Ultra-filtration (UF) module:

- Module: 300 mm long, 23.9 diameter
- Membrane: hollow fibre type (X-flow, Netherlands, RX 300)
 - o Polyethyl sulphone, MWCO: 150-200 kDa
 - o Operated inside-out
 - o Surface 2 × 0.04 m²
 - o Internal diameter: 1.5 mm
 - o Number of fibres: 30

Performance:

	Influent	BAF Effluent	UF Effluent
COD (mg/L)	80.3 ± 34.2	6.9 ± 4.8	5.6 ± 3.6
TSS (mg/L)	51.6 ± 31.7	0.9 ± 0.5	-
Turbidity (NTU)	25.1 ± 14.5	1.2 ± 0.9	0.1 ± 0
Total Coliforms (cfu/100mL)	10 ^{5.8} ± 10 ^{6.5}	10 ^{3.0} ± 10 ^{2.4}	<1
E. Coli (cfu/100mL)	10 ^{4.3} ± 10 ^{4.0}	10 ^{1.9} ± 10 ^{2.1}	<1

Costs: /**Notes: /**

Membrane fouling during domestic water recycling.**B. N. Lodge. 2003.****EngD thesis, Cranfield University.****Scheme details:**

Location: Millennium Dome, London, UK

Commissioned: 1999-2001.

Source: greywater collected from 463 handbasins.

Application: Toilet flushing.

Water quality standards: /

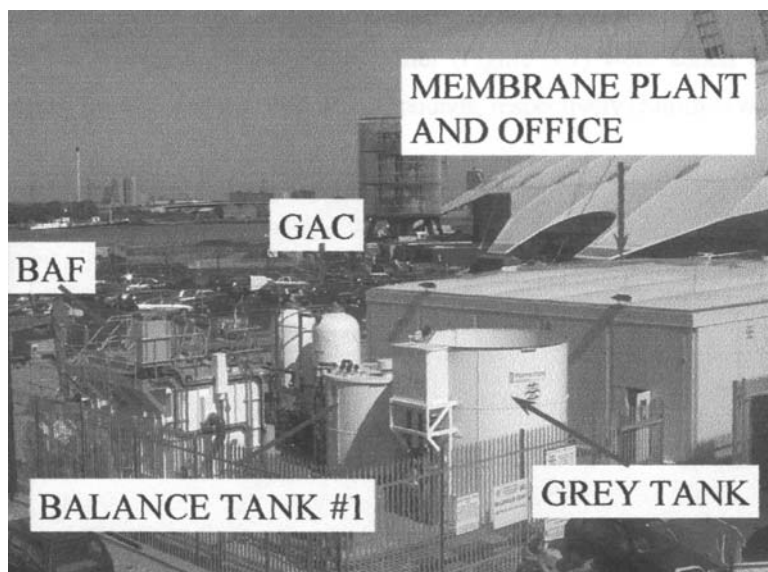
**Design:**

Modular Biological Aerated Filter (BAF) unit (4.65 m × 3.01 m × 3.45 m):

- Feed flow rate: 6-18 L/s
- Aeration flow rate: 130 L/min
- HRT: 75-300 min
- Organic loading rate: 0.4-1.7 kg_{COD}/(m³*day)
- Media: 2 m deep of expended clay (grain size: 2.8-5.7 mm)
- Media volume: 18 m³

Performance:

	Influent	Effluent
COD (mg/L)	84 ± 41	14 ± 14
TSS (mg/L)	31 ± 14	3 ± 3
E. Coli (cfu/100mL)	10 ^{5.4} ± 10 ^{5.6}	10 ^{3.5} ± 10 ^{3.5}

Costs: /**Notes:**

The BAF was used as a pre-treatment before an ultra-filtration module.

Urban greywater reuse at the D'LUX development.

M. Goddard. 2006.

Desalination, 188, 135-140.

Scheme details:

Location: Melbourne, Australia.

Commissioned: October 2004.

Source: greywater collected from 100 apartments.

Application: Toilet flushing and garden watering.

Water quality standards: Victoria regulations for recycled water systems.

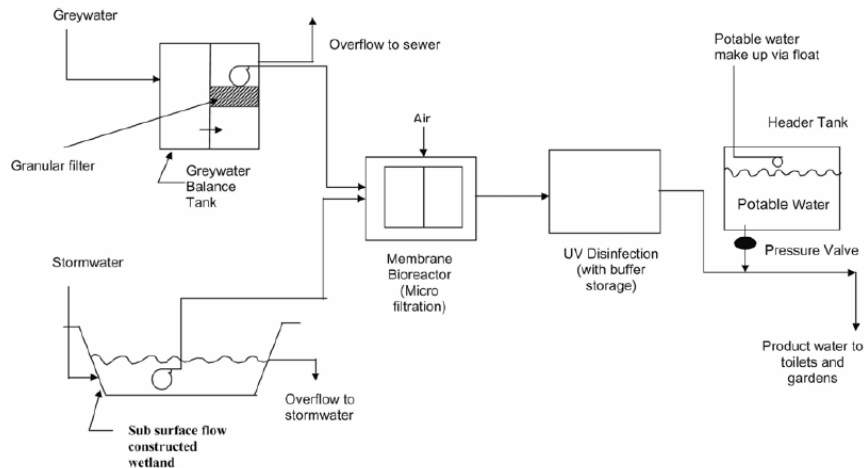

Design:

- Greywater is collected from bathrooms in about 100 of the apartments and stored in a balance tank, which normally overflows to the sewer. This tank is designed to allow sludge to settle in the base and includes a granular filter medium intended to trap lint.
- A subsurface flow constructed wetland which collects stormwater from the site and normally overflows to the local drainage system.
- Both the greywater balance tank and the wetland can be discharged by pumping to a membrane bioreactor, equipped with Kubota membranes with a nominal pore size of 0.4μ .
- The discharge from the bioreactor is disinfected with UV light and pumped to a header tank which feeds a ring main connected to toilets within the apartments and a belowground garden irrigation system. The header tank is provided with a back-up potable water supply.

Performance: /

Costs: /

Notes:

The system is being tested at the moment.

High performance constructed wetlands for cold climates.

P. D. Jenssen, T. Moehlum, T. Krogstad and L. Vrale. 2005.

Journal of Environmental Science and Health, 40 (6-7), 1343-1353.

Scheme details:

Location: Norway.

Commissioned: /

Source: greywater.

Application: /

Water quality standards: /

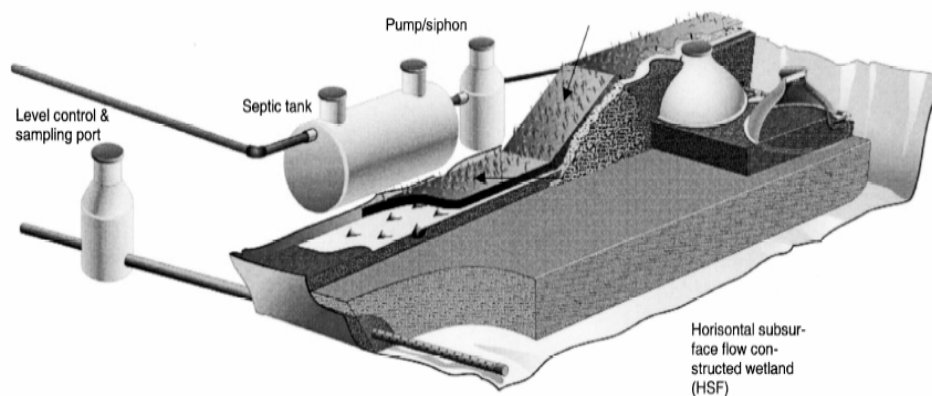
**Design:**

- Pretreatment of the greywater in a septic tank
- Single pass vertical down-flow aerobic biofilter (60 cm deep, grain size 2-10 mm)
- Subsurface horizontal flow porous media filter vegetated with common reed (*Phragmites australis*).

Performance:

Site	Effluent			Removal (%)		
	Kaja	Torvetua	Klosterenga	Kaja	Torvetua	Klosterenga
TP (mg/L)	0.1	0.19	0.2	89	79	-
TN (mg/L)	2.5	2.2	2.5	72	60	-
BOD ₇ (mg/L)	5	<10	-	93	-	-
COD (mg/L)	-	62	19	-	82	-
Total coliforms (cfu/100mL)	<100	<100	-	-	-	-

Costs: /**Notes:** /

An evaluation of single - house greywater recycling systems.

S. Hills, R. Birks, C. Diaper, and P. Jeffrey.

Proceedings of the IWA 4th International Symposium on Wastewater Reclamation & Reuse, November 12-14th, 2003. Mexico City.

Scheme details:

Location: United Kingdom.

Commissioned: April 1999 - May 2000.

Source: Baths and showers.

Application: Toilet flushing.

Water quality standards: /

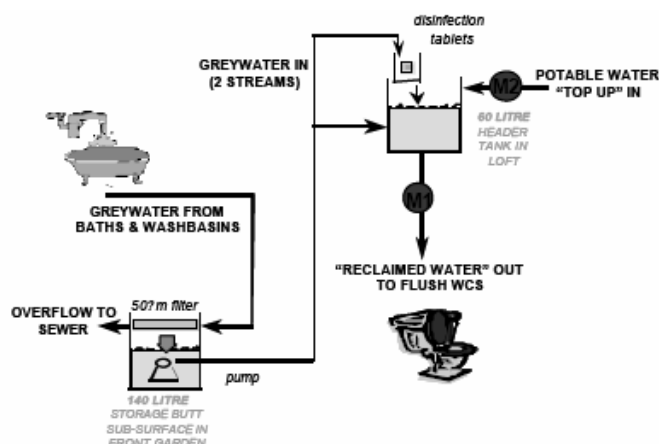

Design:

- Coarse filter (50µm)
- Storage tank
- Disinfection stage (Bromine)

Performance:

House	Occupancy	Effluent					
		Faecal coliforms (cfu/100mL)	BOD (mg/L)	COD (mg/L)	SS (mg/L)	Turbidity (NTU)	Total bromine (mg/L)
A	1 adult	ND	33	202	36	52	45
B	1 adult	ND	22	115	20	18	20
C	1 adult for 8 months then 2	ND	25	121	30	28	41
D	2 adults	ND	32	150	43	37	68
E	2 adults, 1 infant	ND	87	244	47	63	24

Costs:

System cost: £1195

Maintenance cost: £50/year

Notes:

Total water saved: 9-36 %

Problems occurred (sump tank filter blocked, pump failure, lack of disinfection) but were fixed quickly because regular monitoring and sampling was carried out by technical staff that would not be expected in a "real life" situation.

On-site experiments of the slanted soil treatment systems for domestic gray water.

T. Itayama, M. Kiji, A. Suetsugu, N. Tanaka, T. Saito, N. Iwami, M. Mizuochi and Y. Inamori.

Water Science and Technology vol. 53, n°9, pp: 193-201.

Scheme details:

Location: Shikoku Island, Japan

Commissioned: August 2001- January 2004.

Source: kitchen sinks.

Application: garden watering.

Water quality standards: /

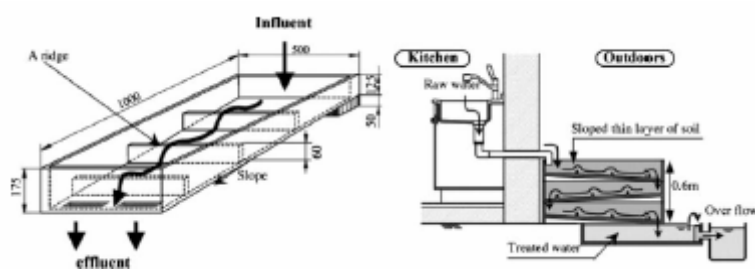
**Design:**

Slanted soil treatment system:

- Hard plastic foam trays (1 m × 50 cm × 17.5 cm)
- Kanuma soil (1 cm diameter particles) mainly composed of alumina and hydrated silica
- Soil layer thickness: 12.5 cm

Performance:

	TN	TP	SS	BOD	COD
Influent (g.m ⁻² .day ⁻¹)	1.78	0.323	9	41.0	23.3
Effluent (g.m ⁻² .day ⁻¹)	0.38	0.046	2	6.8	3.6
Removal (%)	78	86	78	83	85

Costs: /

Notes: /

Development of high-efficiency household biofilm reactor.**M. Imura, Y. Sato, Y. Inamori and R. Sudo. 1995.****Water Science and Technology, 31(9), 163-171.****Scheme details:**

Location: 6-person home, Japan.

Commissioned: /

Source: greywater.

Application: /

Water quality standards: /

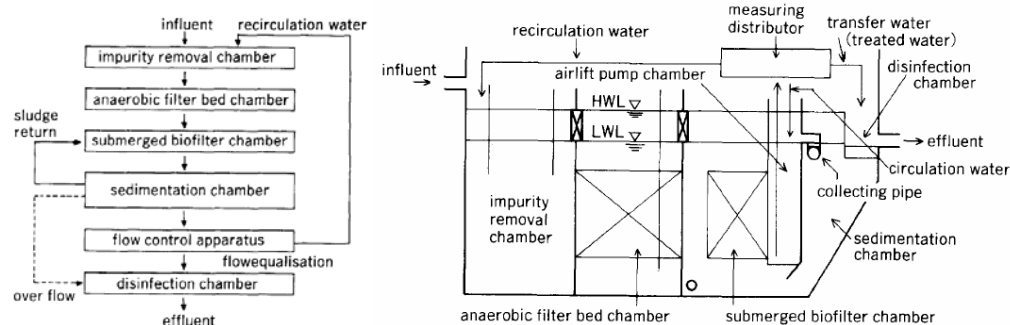
**Design:**

- Impurity removal chamber for removal of solids and oils (0.8 m³)
- Anaerobic filter bed (1.4 m³) with spherical, reticulate plastic media
- Submerged biofilter (1.4 m³) with air mixing (80 L/min)
- Sedimentation tank (0.4 m³)
- The treated water is air lifted (30 L/min) into a measuring distributor which sends water in the impurity removal chamber, the air lift chamber and the disinfection tank.
- Disinfection tank with solid chlorine

Performance:

	TP (mg/L)	TN (mg/L)	NH ₄ -N (mg/L)	SS (mg/L)	COD (mg/L)	BOD (mg/L)	Cl (mg/L)
Treated water	1.2	6.4	4.0	5.9	11.1	7.8	48.8

Costs: /**Notes:**Influent flow rate: 1.735m³/d

West Brunswick sustainable house, Final Project Report.**M. McQuire. 2006.****www.savewater.com.au/index.php?sectionid=196 & www.greenmakeover.com.au****Scheme details:**

Location: West Brunswick, Australia.

Commissioned: May 2005

Source: shower, bathroom basin and laundry.

Application: toilet flushing, laundry and garden watering.

Water quality standards: BOD < 20 mg/L
 SS < 30 mg/L
 E. Coli < 10/100mL

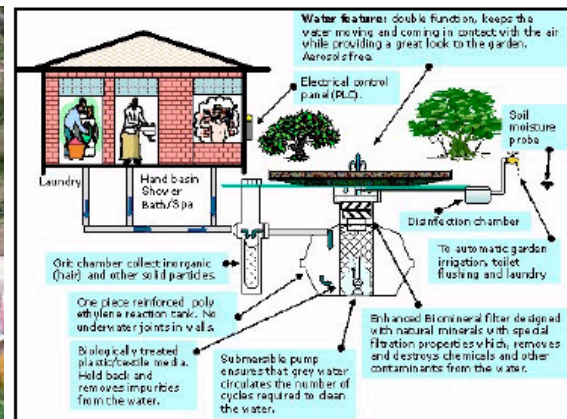
**Design:**

Envirowater system:

- Stocking-like filter to retain the bigger particles (hair...)
- In the treatment tank a float switch activates a pump which sends the water up to a fountain (aeration and circulation of the water)
- The water flows back by gravity in the treatment where it is treated by an bio-film growing on the aggregate balls
- This cycle runs for 9 hours after which a timer controls a solenoid valve that the water to be pump out of the treatment tank.
- The water flows then through a particle filter and a disinfection chamber with UV
- Two large storage sacs (5.500 L)

Performance:

	TP (mg/L)	TN (mg/L)	Turbidity (NTU)	SS (mg/L)	BOD (mg/L)	E. Coli (cfu/100mL)
Treated water	0.6 ± 0.3	5.4 ± 0.7	6.2 ± 6.8	9 ± 15	9 ± 5	0

Costs:

Envirowater unit: Aus\$ 3500

Installation: between Aus\$ 1000 and 3000

Water storage sacs: Aus\$ 1300

Pressure pump with sensor: Aus\$ 400

Notes: /

Treatment of domestic greywater using biological and membrane separation techniques.

M. Ward. 2000.

MPhil thesis, Cranfield University.

Scheme details:

Location: Pilot plant, Cranfield University, UK.

Commissioned: 1999 -2000.

Source: bathroom greywater.

Application: /

Water quality standards: /

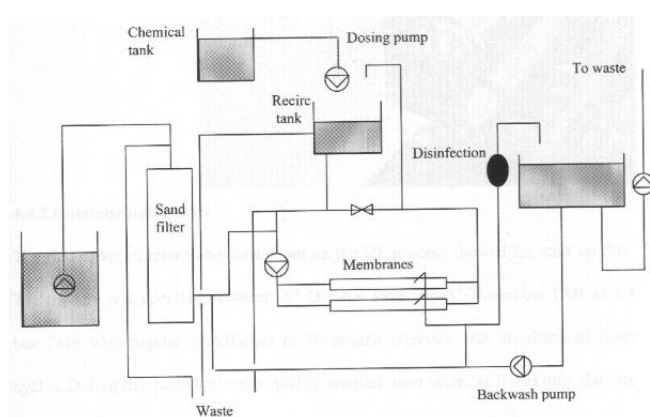

Design:

The greywater was pumped from a holding tank into a sand filter consisting of a 150 mm-diameter clear PVC column filled with 400 mm of 8/16 grade filtration sand and supported by 200 mm of 6 mm gravel.

The greywater was then pumped in 2 Exflow R-25 hollow fibre membrane modules (inside-out) at 6000 L/h corresponding to a crossflow velocity of 1m/s. The hollow fibre tubes had a 2 mm diameter and corresponded to 2.5 m² per module.

Finally the greywater underwent disinfection in a swimming pool brominator.

Performance:

	Influent	Sand filter	Effluent
COD (mg/L)	65	74	18
BOD (mg/L)	23	17	8
Turbidity (NTU)	17.8	17.6	0.4
NH ₃ (mg/L)	1.1		0.8
E. Coli (cfu/100mL)	5.4*10 ³		0
Total Coliforms (cfu/100mL)	10 ⁴		0-10 ³

Costs: /

Notes: /

Treatment of domestic greywater using biological and membrane separation techniques.**M. Ward. 2000.****MPhil thesis, Cranfield University.****Scheme details:**

Location: Pilot plant, Cranfield University, UK.

Commissioned: 1999 -2000.

Source: bathroom greywater.

Application: /

Water quality standards: /

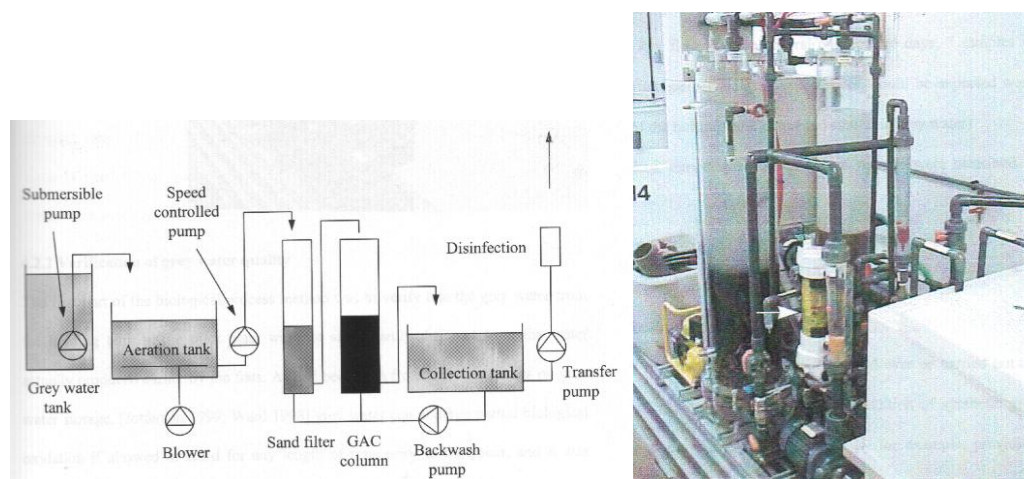
**Design:**

The greywater was pumped from a holding tank into a 280 L biological treatment tank filled with 30% volume of seeded Kaldnes media with aeration at the bottom.

The greywater was then transferred to a sand filter by a speed controlled pump. The sand filter was a clear Perspex 200 mm diameter column filled with 700 mm of 8/16 grade filtration sand supported by 200 mm of 6 mm gravel.

Finally the greywater was then pump into a GAC column (300 mm diameter) filled with 500 mm of TLA 30 carbon and 200 mm of 6 mm gravel.

Performance:

Flow rate (L/h)		50	60	120	140	160	200
BOD (mg/L)	In	23	-	21	17	30	17
	Out	4	-	2	2	2	2
COD (mg/L)	In	35	28	34	48	45	44
	Out	7	14	12	11	23	23
Turbidity (NTU)	In	17	20	20	24	25	22
	Out	0.3	0.4	0.6	0.9	1.0	0.9
E. Coli (cfu/100mL)	In	$>2 \cdot 10^2$	$>2 \cdot 10^2$	$>2 \cdot 10^2$	$2.8 \cdot 10^3$	$4 \cdot 10^2$	-
	Out	<1	<1	<1	<1	1.4	-
Total coliforms (cfu/100mL)	In	$2 \cdot 10^2$	$2 \cdot 10^2$	$2 \cdot 10^2$	$2.7 \cdot 10^3$	$1 \cdot 10^2$	-
	Out	$8 \cdot 10^2$	<1	<1	<1	$2 \cdot 10^2$	-

Costs: /**Notes: /**

R. Frazer-Williams. 2006.
PhD thesis, Cranfield University.

Scheme details:

Location: Pilot plant, Cranfield University, UK.

Commissioned: 2004 - 2006.

Source: bathroom greywater.

Application: /

Water quality standards: /



Design:

One horizontal sub-surface flow reed bed and one vertical flow reed bed, ('RIBS' – Oceans-ESU, Bradford, UK) were planted with *Phragmites australis* in a sand:soil:compost medium (ratio 65:25:10) with coarse (20 mm) gravel around the inlet zone for the HFRB and around the collection/outlet zones for both beds. Both beds were otherwise identical with a surface area of 6m² and media to a depth of 0.7 m.

Performance:

	Influent	Horizontal	Vertical
COD (mg/L)	452 ± 209	111 ± 57	27 ± 29
BOD (mg/L)	151 ± 51	51 ± 35	5 ± 6
Turbidity (NTU)	63 ± 88	12 ± 13	2 ± 2
NH ₄ ⁺ (mg/L)	0.3 ± 0.3	0.4 ± 0.4	0.1 ± 0.1
NO ₃ ⁻ (mg/L)	1.2 ± 1.2	0.7 ± 0.1	0.6 ± 0.1
PO ₄ ³⁻ (mg/L)	0.3 ± 0.2	0.5 ± 0.2	0.1 ± 0.1
Total coliforms (cfu/100mL)	6*10 ⁷ ± 9*10 ⁷	10 ⁴ ± 10 ⁴	2*10 ⁴ ± 3*10 ⁴
E. Coli (cfu/100mL)	2*10 ³ ± 2*10 ⁵	1 ± 1	4 ± 7
SS (mg/L)	87 ± 65	31 ± 16	9 ± 6

Costs: /

Notes: /

R. Frazer-Williams. 2006.
PhD thesis, Cranfield University.

Scheme details:

Location: Pilot plant, Cranfield University, UK.

Commissioned: 2004 - 2006.

Source: bathroom greywater.

Application: /

Water quality standards: /



Design:

A novel constructed wetland system; the patent ‘GROW’ Green Roof Water Recycling System (WWUK, London, UK). The GROW system is designed to sit on a pitched roof suitable for use in urban new developments where ground space is limited. However, with a wooden frame, GROW may be used on a flat roof or at ground level. The test rig comprised five rows of two troughs connected in series and placed onto a tiered wooden framework to represent a sloping roof. The first trough was approximately 1m above the ground and the lowest was 0.7m above ground. A baffle and a weir within each trough are intended to force the flow through the whole of the media, reducing the potential for short-circuiting. The troughs were aerated for one hour each day *via* a porous hose. Troughs were filled to approximately 10 cm depth with Optiroc (light-weight expanded clay) and topped with gravel chippings (10 – 20mm diameter) to 16 cm. Troughs were planted as follows; trough 1 unplanted; trough 2 with 6 plants of *Iris pseudocorus*; trough 3 with 8 plants of *Veronica beccabunga* ; trough 4 with 6 plants of *Glyceria variegates* ; trough 5 with 6 plants of *Juncus effusus* ; trough 6 with 6 plants of *Iris versicolor* ; trough 7 with 7 plants of *Caltha palustris* ; trough 8 with 8 plants of *Lobelia cardinalis* ; troughs 9 and 10 each with 7 plants of *Mentha aquatica*. The outflow pipe carrying the treated GROW effluent is at the end of trough 10 which also contains a coarse media restrainer mesh. The entire system was covered with a reinforced membrane to prevent entry of rainwater.

Performance:

	Influent	Effluent
COD (mg/L)	452 ± 209	139 ± 78
BOD (mg/L)	151 ± 51	71 ± 44
Turbidity (NTU)	63 ± 88	26 ± 13
NH ₄ ⁺ (mg/L)	0.3 ± 0.3	0.2 ± 0.1
NO ₃ ⁻ (mg/L)	1.2 ± 1.2	0.7 ± 0.1
PO ₄ ³⁻ (mg/L)	0.3 ± 0.2	1.0 ± 0.8
Total coliforms (cfu/100mL)	6*10 ⁷ ± 9*10 ⁷	2*10 ⁶ ± 2*10 ⁶
E. Coli (cfu/100mL)	2*10 ³ ± 2*10 ⁵	5*10 ² ± 8*10 ²
SS (mg/L)	87 ± 65	19 ± 9

Costs: /

Notes: /

Recycled vertical flow constructed wetland (RVFCW) – a novel method of recycling greywater for irrigation in small communities.

A. Gross, O. Shmueli, Z. Ronen and E. Raveh. 2006.

Chemosphere, in press.

Scheme details:

Location: 5 person house, Israel.

Commissioned: /

Source: laundry, showers and sinks.

Application: irrigation.

Water quality standards: BOD < 10 mg/L
 SS < 10 mg/L
 Faecal coliforms < 1 cfu/100mL



Design:

- 40-litre sedimentation tank
- Vertical flow constructed wetland (500-liter tank) composed of a three-layer bed consisting of 15 cm planted organic soil over a 30 cm layer of tuff or plastic media and a 5 cm lower layer limestone pebbles. The bottom of the tank was perforated and the water flowed in a 500-liter reservoir placed under the constructed wetland.
- Treated water was recirculated at a flow of 390 L/h from the reservoir in to the constructed wetland so that the water passed through the constructed wetland between 7 and 21 times.
- The treated water was then overflowing into a second 40-litre sedimentation tank.

Performance:

	Influent	Effluent
COD (mg/L)	839 ± 47	157 ± 62
BOD (mg/L)	466 ± 66	0.7 ± 0.3
TN (mg/L)	34.3 ± 2.6	10.8 ± 3.4
NO ₃ ⁻ (mg/L)	3.0 ± 1.3	8.6 ± 4.3
TP (mg/L)	22.8 ± 1.8	6.6 ± 1.1
Faecal coliforms (cfu/100mL)	5*10 ⁷ ± 2*10 ⁷	2*10 ⁵ ± 10 ⁵
SS (mg/L)	158 ± 30	3 ± 1

Costs: /

Notes:

Greywater: 450 L/day.

Grey water treatment with a membrane bioreactor operated at low SRT and low HRT.**B. Lesjean and R. Gnirss. 2006.****Desalination, 199, 432-434.****Scheme details:**

Location: Germany.

Commissioned: /

Source: bathroom and kitchen.

Application: /

Water quality standards: /

Design:

Membrane bioreactor

Performance:

	Influent	Effluent
COD (mg/L)	493	24
TN (mg/L)	21	10
NH ₄ ⁺ (mg/L)	5.7	<0.2
TP (mg/L)	22.8 ± 1.8	6.6 ± 1.1
SS (mg/L)	7.4	3.5

Costs: /**Notes:**

Design, construction and evaluation of an ablution water treatment unit in Oman: a case study.

S. A. Prathapar, M. Ahmed, S. Al Adawi and S. Al Sidiari. 2006.
International Journal of Environmental Studies, 63(3), 283-292.

Scheme details:

Location: Mosque of Al Hail South, Oman.

Commissioned: 2005

Source: ablution water.

Application: irrigation.

Water quality standards: BOD < 15 mg/L
COD < 150 mg/L
SS < 15 mg/L
Total Coliforms < 200 cfu/100mL

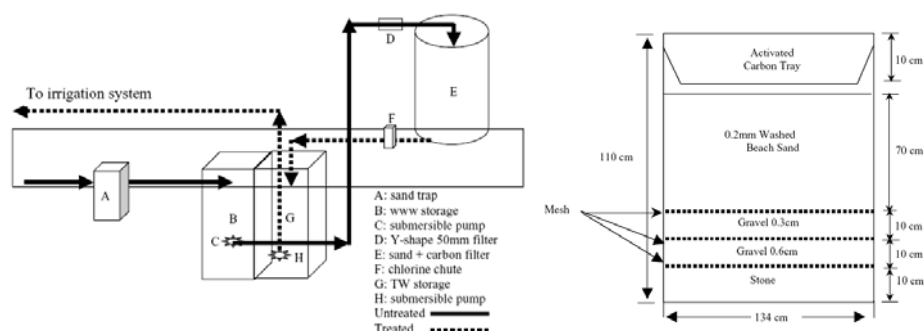

Design:

- Sand trap
- Storage tank (1.5m×1.5m×1.7m)
- Drip-irrigation filter
- Filter: 10 cm-deep of activated carbon tray, 70 cm-deep of 0.2mm washed beach sand, 10 cm-deep of 0.32 cm gravel, 10 cm-deep of 0.62 cm gravel and stones.
- Chlorination chute
- Storage tank (1.5m×1.5m×1.7m)

Performance:

	Influent	Effluent
COD (mg/L)	51.47 ± 12.80	34.53 ± 8.50
Turbidity (NTU)	12.6 ± 4.20	6.03 ± 0.68
E. Coli (cfu/100mL)	>200	0
Total coliforms (cfu/100mL)	>200	0
SS (mg/L)	9.39 ± 8.20	3.69 ± 2.17

Costs:

Initial costs:	Operating costs
Construction of storage tank and plumbing: 550 RO	Electricity/year: 15 RO
Fabrication of the filter: 100 RO	Maintenance/year: 40 RO
Filter filling materials and labour: 58 RO	Chlorine/year: 25 RO
Drip irrigation filter: 11 RO	
Pumps: 142 RO	
Electricals and others: 104 RO	

Notes:

Water price: 0.6RO/m³

**Appendix III:
Constructed wetlands descriptions and performances.**

Descriptions:

Both reed beds ('RIBS' – Oceans-ESU, Bradford, UK) were planted with *Phragmites australis* in a sand:soil:compost medium (ratio 65:25:10) with coarse (20 mm) gravel at the inlet of the HFRB and at the outlet zone of both systems. The two systems were otherwise identical with a surface area of 6 m² and a media depth of 0.7 m. The systems were fed with 480 L.d⁻¹ of greywater, continuously for the HFRB and supplied as ten batches over 24 hours for the VFRB corresponding to retention times of 2.1 days and 2 hours for the HFRB and the VFRB respectively. The GROW system (WWUK, London, UK) was designed to sit on a pitched roof suitable for use in urban environments where space is limited. The pilot comprised five rows of two troughs in series. Troughs were filled with a 10-cm-deep layer of Optiroc (light-weight expanded clay) and topped with about 6 cm of gravel chippings (10 – 20mm diameter) and planted with different types of plants.

Trough	Plants	
	Number	Type
1	-	unplanted
2	6	<i>Iris pseudocorus</i>
3	8	<i>Veronica beccabunga</i>
4	6	<i>Glyceria variegates</i>
5	6	<i>Juncus effusus</i>
6	6	<i>Iris versicolor</i>
7	7	<i>Caltha palustris</i>
8	8	<i>Lobelia cardinalis</i>
9 & 10	7	<i>Mentha aquatica</i>

The entire system was covered with a reinforced membrane to prevent entry of rainwater. The greywater to be treated entered the inlet well at the top into the first trough. At the end of each row the water flowed from a well down a weir to the next one. A screening step was implemented at the inlet to remove hair and other large particles that could potentially clog the system. A coarse mesh was also installed at the outlet to stop media to be flushed out with the effluent. Similarly to the HFRB, the GROW was fed with 480 L.d⁻¹ of greywater on a continuous mode corresponding to a retention time of 2.1 days.

Performances:

Constructed wetlands effluent quality with low strength greywater:

	Influent	HFRB	VFRB	GROW
COD (mg.L ⁻¹)	83 ± 27	29 ± 23	21 ± 23	19 ± 20
BOD (mg.L ⁻¹)	19 ± 7	2 ± 2	1 ± 2	2 ± 2
Turbidity (NTU)	20.0 ± 17.4	18.9 ± 19.3	11.3 ± 9.0	0.8 ± 1.8
NH ₄ ⁺ (mg.L ⁻¹)	1.6 ± 1.7	0.8 ± 0.7	0.1 ± 0.2	0.5 ± 0.9
NO ₃ ⁻ (mg.L ⁻¹)	1.6 ± 0.9	1.2 ± 0.7	2.6 ± 2.0	1.7 ± 1.0
PO ₄ ³⁻ (mg.L ⁻¹)	0.7 ± 0.3	0.3 ± 0.2	0.1 ± 0.2	0.6 ± 0.4
SS (mg.L ⁻¹)	29 ± 34	9 ± 9	2 ± 2	3 ± 3
Total coliforms (cfu/100mL)	10 ⁶ ± 2×10 ⁶	2×10 ³ ± 3×10 ³	2×10 ¹ ± 5×10 ¹	4×10 ² ± 8×10 ²
<i>E. Coli</i> (cfu/100mL)	2×10 ³ ± 4×10 ³	6×10 ¹ ± 2×10 ²	0 ± 0	2 ± 7

Constructed wetlands effluent quality with high strength greywater:

	Influent	HFRB	VFRB	GROW
COD (mg.L ⁻¹)	452 ± 209	111 ± 57	27 ± 29	139 ± 78
BOD (mg.L ⁻¹)	151 ± 51	51 ± 35	5 ± 6	71 ± 44
Turbidity (NTU)	47.2 ± 29.2	11.9 ± 13.0	2.2 ± 1.5	25.3 ± 13.4
NH ₄ ⁺ (mg.L ⁻¹)	0.3 ± 0.3	0.4 ± 0.4	0.1 ± 0.1	0.2 ± 0.1
NO ₃ ⁻ (mg.L ⁻¹)	1.2 ± 1.2	0.7 ± 0.1	0.6 ± 0.1	0.7 ± 0.1
PO ₄ ³⁻ (mg.L ⁻¹)	0.3 ± 0.2	0.5 ± 0.2	0.1 ± 0.1	1.0 ± 0.8
SS (mg.L ⁻¹)	87 ± 65	31 ± 16	9 ± 6	19 ± 9
Total coliforms (cfu/100mL)	5×10 ⁷ ± 8×10 ⁷	5×10 ⁴ ± 10 ⁵	3×10 ⁴ ± 4×10 ⁴	10 ⁶ ± 10 ⁶
<i>E. Coli</i> (cfu/100mL)	4×10 ⁴ ± 10 ⁵	3×10 ² ± 8×10 ²	1×10 ² ± 2×10 ²	10 ³ ± 2×10 ³

**Appendix IV:
Shower gels compositions.**

	Lynx	Tesco	Imperial Leather	Boots	Original Source
Aqua	√	√	√	√	√
Sodium laureth sulfate	√	√	√	√	√
Di/tetrasodium EDTA	√	√	√	√	√
Parfum	√	√	√	√	
Sodium chloride		√	√	√	√
CI42090		√	√	√	√
Citric acid		√	√	√	
Cocamidopropyl betaine	√	√		√	
Glycerin	√		√	√	
Limonene	√			√	√
Cocamide DEA				√	√
Phenoxyethanol			√	√	
Linalool				√	√
Styrene/acrylates copolymer				√	√
CI19140			√		√
Methylchloroisothiazolinone	√				√
Methylisothiazolinone	√				√
Lactic acid	√				√
Citral				√	√
Citrus				√	√
Sodium lauryl sulphate				√	√
Sodium hydroxide	√	√			
Sodium benzoate		√	√		
Sodium pareth sulfate	√				
DMDM hydantoin	√				
Acrylates palmeth 25/Acrylate copolymer	√				
Isopropyl palmitate	√				
Benzophenone 4	√				
Formic acid	√				
Benzyl salicylate	√				
Iodopropynyl butylcarbonate	√				
CI74160	√				
Decyl glucoside	√				
Polysorbate 20		√			
Sorbic acid		√			
Chamomilla Recutita		√			
Thymus Vulgaris		√			
Propylparaben		√			
CI 47005		√			
Hamamelis Virginiana		√			
Humulus Lupulus		√			
Methylparaben		√			
Rosmarinus Officinalis		√			
Polyquaternium 7		√			

Propylene glycol	√		
Formaldehyde	√		
Ethoxydiglicol	√		
Disodium Lauramido MEA- Sulfocinate		√	
Guar Hydroxipropyltrimonium chloride		√	
Sodium citrate		√	
Disodium phosphate		√	
Lauramidopropyl betaine		√	
PEG-7 glyceril cocoate		√	
Methyldibromoglutanronitrile		√	
Hexylene glycol		√	
Glycol distearate			√
Potassium sorbate			√
Laureth-4 tricitum vulgare			√
Disodium phosphate			√
Coumarin			√
Ocimum basilicum			√
Aurantium bergamia			√
Denatorium benzoate			√
Benzoic acid			√
PEG-150 distearate			√
Sodium lactate			√
Lauryl betaine			√
Magnesium nitrate			√
Magnesium chloride			√

**Appendix V:
Examples of Microtox results.**

MicrotoxOmni Test Report

Date: 12/07/2006 05:26 PM

Test Protocol: 81.9% Basic Test
 Sample: all purpose orange 1
 Toxicant: all purpose orange cleaner
 Reagent Lot no.: -
 Test description: all purpose
 Test name: all purpose orange 1
 Database file: C:\Program Files\MicrotoxOmni\db1.mdb

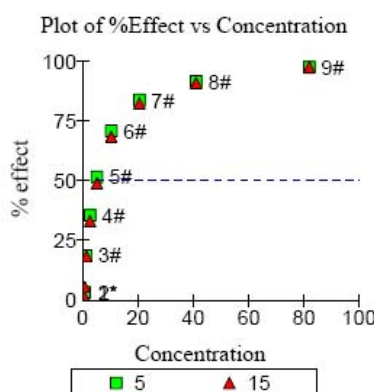
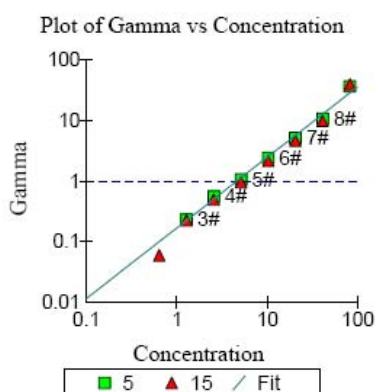

Sample	Conc	5 Mins Data:				15 Mins Data:		
		Io	It	Gamma	% effect	It	Gamma	% effect
Control	0.000	95.82	113.83	1.188 #		117.96	1.231 #	
1	0.3199	85.09	98.01	0.0313 *	3.040%	102.83	0.0186 *	1.834%
2	0.6398	86.34	99.19	0.0340 *	3.294%	100.35	0.0591 #	5.588%
3	1.280	91.37	88.21	0.2305 #	18.73%	91.74	0.2261 #	18.44%
4	2.559	94.34	72.18	0.5527 #	35.59%	77.69	0.4949 #	33.11%
5	5.119	100.08	57.54	1.066 #	51.60%	62.96	0.9569 #	48.90%
6	10.24	89.75	31.15	2.423 #	70.78%	34.96	2.160 #	68.36%
7	20.48	97.38	18.87	5.131 #	83.69%	21.29	4.631 #	82.24%
8	40.95	89.67	9.08	10.73 #	91.48%	10.18	9.844 #	90.78%
9	81.90	89.33	2.83	36.50 #	97.33%	2.71	39.58 #	97.54%

- used in calculation; * - invalid data; D - deleted from calcs.

Calculations on 5 Mins data:
 EC50 Concentration:4.654% (95% confidence range: 4.029 to 5.375)
 95% Confidence Factor: 1.155
 Estimating Equation:LOG C =0.8498 x LOG G +0.6678
 Coeff. of Determination (R²):0.9938
 Slope: 1.169
 Correction Factor: 1.188

Calculations on 15 Mins data:
 EC50 Concentration:5.251% (95% confidence range: 4.455 to 6.188)
 95% Confidence Factor: 1.179
 Estimating Equation:LOG C =0.8011 x LOG G +0.7202
 Coeff. of Determination (R²):0.9897

MicrotoxOmni Test Report

Date: 25/07/2006 12:52 PM

Test Protocol: 81.9% Basic Test

Sample: cyclon 3 (0.2 g/L)

Toxicant: cyclon 3 (0.2 g/L)

Reagent Lot no.: -

Test description: cyclon washing 3

Test name: cyclon 3 (0.2 g/L)

Database file: C:\Program Files\MicrotoxOmni\db1.mdb

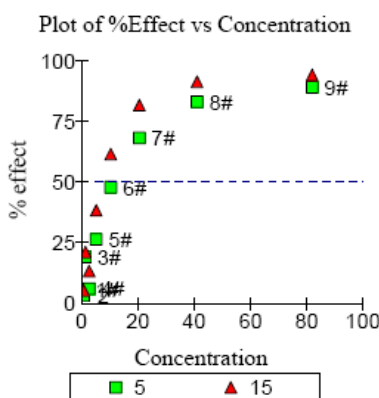
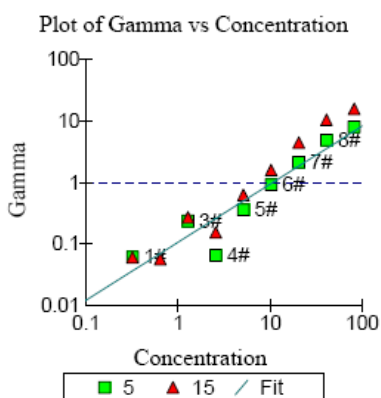

Sample	Conc	5 Mins Data:				15 Mins Data:		
		Io	It	Gamma	% effect	It	Gamma	% effect
Control	0.000	104.08	119.34	1.147 #		124.59	1.197 #	
1	0.3199	97.25	105.03	0.0616 #	5.810%	109.80	0.0602 #	5.682%
2	0.6398	94.31	104.65	0.0333 *	3.225%	106.84	0.0566 #	5.363%
3	1.280	109.88	101.93	0.2360 #	19.10%	103.64	0.2691 #	21.21%
4	2.559	87.29	94.01	0.0646 #	6.073%	90.58	0.1536 #	13.31%
5	5.119	96.00	81.02	0.3586 #	26.40%	70.87	0.6215 #	38.33%
6	10.24	82.36	49.20	0.9194 #	47.90%	38.05	1.591 #	61.41%
7	20.48	92.94	34.00	2.134 #	68.10%	20.51	4.424 #	81.56%
8	40.95	93.52	18.24	4.879 #	82.99%	9.79	10.44 #	91.25%
9	81.90	99.84	12.57	8.107 #	89.02%	7.09	15.86 #	94.07%

- used in calculation; * - invalid data; D - deleted from calcs.

Calculations on 5 Mins data:

EC50 Concentration:10.16% (95% confidence range: 5.546 to 18.63)

95% Confidence Factor: 1.833

Estimating Equation:LOG C =0.9359 x LOG G +1.007

Coeff. of Determination (R²):0.8851

Slope: 0.9457

Correction Factor: 1.147

Calculations on 15 Mins data:

EC50 Concentration:6.381% (95% confidence range: 4.603 to 8.845)

95% Confidence Factor: 1.386

Estimating Equation:LOG C =0.8693 x LOG G +0.8049

Coeff. of Determination (R²):0.9590

MicrotoxOmni Test Report

Date: 25/07/2006 11:18 AM

Test Protocol: 81.9% Basic Test
 Sample: ecover 3 (0.2 g/L)
 Toxicant: ecover (0.2 g/L)
 Reagent Lot no.: -
 Test description: ecover washing 3
 Test name: ecover 3 (0.2 g/L)
 Database file: C:\Program Files\MicrotoxOmni\db1.mdb

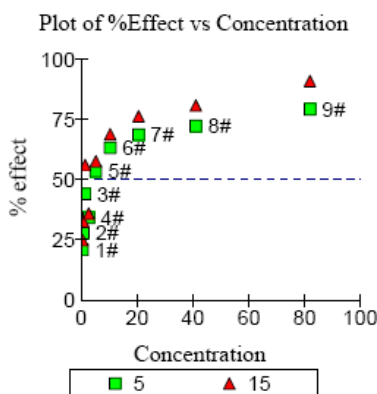
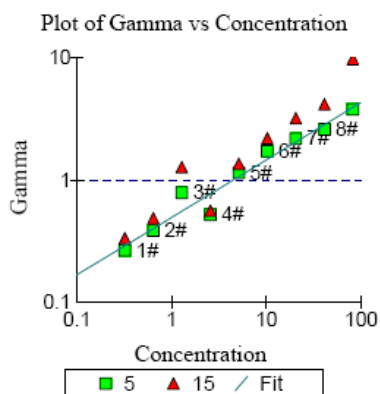

Sample	Conc	5 Mins Data:				15 Mins Data:			
		Io	It	Gamma	% effect	It	Gamma	% effect	
Control	0.000	93.87	127.34	1.357 #		124.45	1.326 #		
1	0.3199	99.81	107.12	0.2640 #	20.89%	99.37	0.3316 #	24.90%	
2	0.6398	104.24	102.07	0.3854 #	27.82%	93.08	0.4847 #	32.65%	
3	1.280	104.79	79.60	0.7858 #	44.00%	61.14	1.272 #	55.99%	
4	2.559	84.90	75.79	0.5196 #	34.19%	72.21	0.5588 #	35.85%	
5	5.119	105.88	66.88	1.148 #	53.44%	59.61	1.355 #	57.53%	
6	10.24	106.40	53.10	1.718 #	63.21%	44.14	2.196 #	68.71%	
7	20.48	110.31	46.96	2.187 #	68.62%	34.76	3.207 #	76.23%	
8	40.95	103.62	39.14	2.591 #	72.16%	26.54	4.176 #	80.68%	
9	81.90	108.78	30.81	3.790 #	79.12%	13.33	9.819 #	90.76%	

- used in calculation; * - invalid data; D - deleted from calcs.

Calculations on 5 Mins data:
 EC50 Concentration: 4.510% (95% confidence range: 3.168 to 6.420)
 95% Confidence Factor: 1.423
 Estimating Equation: LOG C = 2.017 x LOG G + 0.6542
 Coeff. of Determination (R²): 0.9515
 Slope: 0.4717
 Correction Factor: 1.357

Calculations on 15 Mins data:
 EC50 Concentration: 2.569% (95% confidence range: 1.539 to 4.289)
 95% Confidence Factor: 1.669
 Estimating Equation: LOG C = 1.632 x LOG G + 0.4098
 Coeff. of Determination (R²): 0.9117

MicrotoxOmni Test Report

Date: 12/07/2006 03:37 PM

Test Protocol: 81.9% Basic Test
 Sample: flash forest pine 1
 Toxicant: flash all purpose
 Reagent Lot no.: -
 Test description: flash forest pine
 Test name: flash forest pine 1
 Database file: C:\Program Files\MicrotoxOmni\db1.mdb

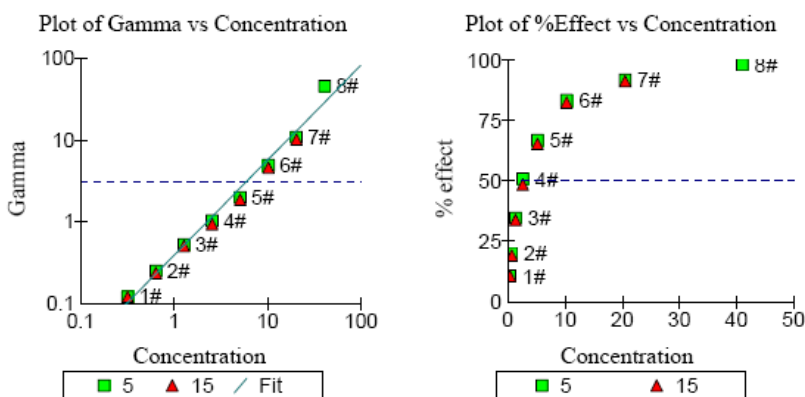

Sample	Conc	5 Mins Data:				15 Mins Data:		
		Io	It	Gamma	% effect	It	Gamma	% effect
Control	0.000	95.82	111.44	1.163 #		105.90	1.105 #	
1	0.3199	91.61	95.04	0.1210 #	10.80%	90.37	0.1204 #	10.74%
2	0.6398	95.87	89.10	0.2514 #	20.09%	85.60	0.2378 #	19.21%
3	1.280	91.75	69.75	0.5298 #	34.63%	67.13	0.5105 #	33.80%
4	2.559	89.84	51.30	1.037 #	50.90%	51.18	0.9400 #	48.45%
5	5.119	93.91	36.29	2.010 #	66.77%	36.03	1.881 #	65.29%
6	10.24	97.00	19.01	4.934 #	83.15%	19.02	4.636 #	82.26%
7	20.48	94.69	9.18	11.00 #	91.66%	9.26	10.30 #	91.15%
8	40.95	96.97	2.39	46.19 #	97.88%	0.93	114.2 *	99.13%
9	81.90	95.33	0.74	148.8 *	99.33%	0.39	269.1 *	99.63%

- used in calculation; * - invalid data; D - deleted from calcs.

Calculations on 5 Mins data:
 EC50 Concentration: 2.264% (95% confidence range: 1.867 to 2.747)
 95% Confidence Factor: 1.213
 Estimating Equation: LOG C = 0.8464 x LOG G + 0.3550
 Coeff. of Determination (R²): 0.9864
 Slope: 1.165
 Correction Factor: 1.163

Calculations on 15 Mins data:
 EC50 Concentration: 2.488% (95% confidence range: 2.290 to 2.704)
 95% Confidence Factor: 1.087
 Estimating Equation: LOG C = 0.9399 x LOG G + 0.3959
 Coeff. of Determination (R²): 0.9973

MicrotoxOmni Test Report

Date: 07/08/2006 11:09 AM

Test Protocol: 81.9% Basic Test

Sample: Johnsons 2 (1/1000)

Toxicant: -

Reagent Lot no.: -

Test description: Johnsons 2 shower (1/1000)

Test name: Johnsons shower 2 (1/1000)

Database file: C:\Program Files\MicrotoxOmni\db1.mdb

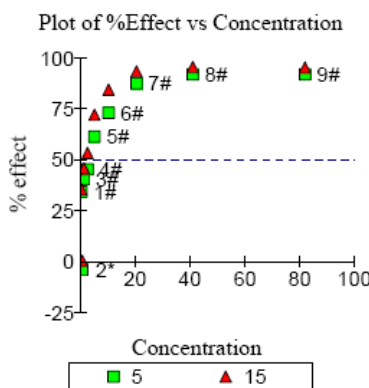
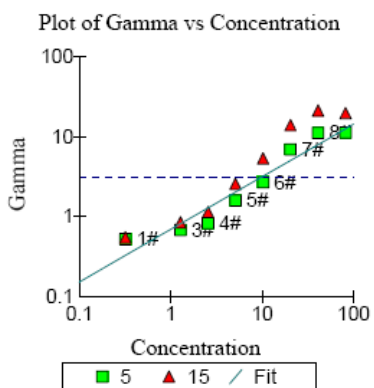

Sample	Conc	5 Mins Data:				15 Mins Data:		
		Io	It	Gamma	% effect	It	Gamma	% effect
Control	0.000	91.76	141.38	1.541 #		134.70	1.468 #	
1	0.3199	132.26	133.94	0.5214 #	34.27%	125.31	0.5494 #	35.46%
2	0.6398	79.65	127.69	-0.0389 *	-4.049%	116.41	0.0044 *	0.4388%
3	1.280	138.91	127.38	0.6802 #	40.48%	110.42	0.8467 #	45.85%
4	2.559	128.39	108.28	0.8269 #	45.26%	88.09	1.140 #	53.26%
5	5.119	151.00	89.80	1.591 #	61.40%	61.83	2.585 #	72.11%
6	10.24	123.29	51.30	2.703 #	72.99%	28.42	5.368 #	84.30%
7	20.48	127.65	24.78	6.937 #	87.40%	12.49	14.00 #	93.33%
8	40.95	146.44	18.44	11.24 #	91.83%	9.63	21.32 #	95.52%
9	81.90	143.78	17.99	11.31 #	91.88%	10.16	19.77 #	95.19%

- used in calculation; * - invalid data; D - deleted from calcs.

Calculations on 5 Mins data:

EC50 Concentration: 1.920% (95% confidence range: 1.094 to 3.371)

95% Confidence Factor: 1.756

Estimating Equation: LOG C = 1.415 x LOG G + 0.2833

Coeff. of Determination (R²): 0.9317

Slope: 0.6585

Correction Factor: 1.541

Calculations on 15 Mins data:

EC50 Concentration: 1.296% (95% confidence range: 0.7323 to 2.295)

95% Confidence Factor: 1.770

Estimating Equation: LOG C = 1.223 x LOG G + 0.1128

Coeff. of Determination (R²): 0.9438

MicrotoxOmni Test Report

Date: 31/07/2006 02:09 PM

Test Protocol: 81.9% Basic Test
 Sample: Bettabuy 1 (1/500)
 Toxicant: Bettabuy shampoo (1/500)
 Reagent Lot no.: -
 Test description: Bettabuy shampoo Morrisons
 Test name: bettabuy 1 (1/500)
 Database file: C:\Program Files\MicrotoxOmni\db1.mdb

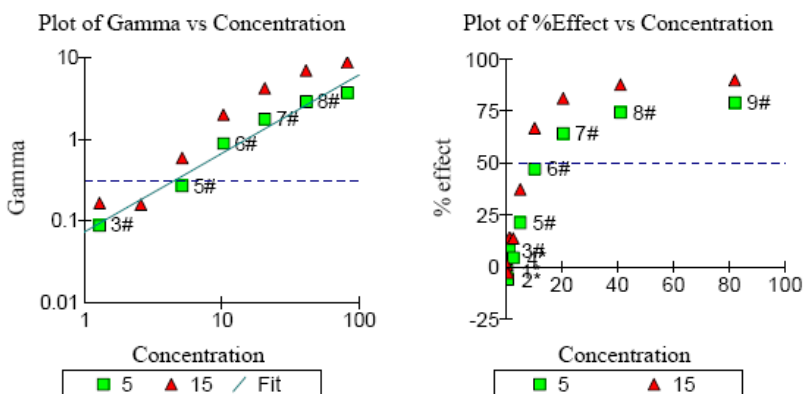

Sample	Conc	5 Mins Data:				15 Mins Data:		
		Io	It	Gamma	% effect	It	Gamma	% effect
Control	0.000	96.46	58.64	0.6079 #		54.08	0.5606 #	
1	0.3199	91.71	56.64	-0.0156 *	-1.592%	50.94	0.0093 *	0.9276%
2	0.6398	90.61	58.38	-0.0564 *	-5.984%	52.17	-0.0262 *	-2.696%
3	1.280	102.50	57.24	0.0886 #	8.139%	49.28	0.1661 #	14.25%
4	2.559	93.38	54.29	0.0456 *	4.364%	45.19	0.1585 #	13.68%
5	5.119	95.95	45.92	0.2703 #	21.28%	33.73	0.5948 #	37.30%
6	10.24	107.74	34.57	0.8946 #	47.22%	20.08	2.008 #	66.76%
7	20.48	98.90	21.55	1.790 #	64.16%	10.56	4.251 #	80.96%
8	40.95	100.35	15.63	2.903 #	74.38%	7.02	7.014 #	87.52%
9	81.90	98.46	12.53	3.777 #	79.07%	5.60	8.857 #	89.86%

- used in calculation; * - invalid data; D - deleted from calcs.

Calculations on 5 Mins data:
 EC50 Concentration:14.92% (95% confidence range: 10.69 to 20.81)
 95% Confidence Factor: 1.395
 Estimating Equation:LOG C =1.007 x LOG G +1.174
 Coeff. of Determination (R²):0.9696
 Slope: 0.9626
 Correction Factor: 0.6079

Calculations on 15 Mins data:
 EC50 Concentration:7.901% (95% confidence range: 5.454 to 11.45)
 95% Confidence Factor: 1.449
 Estimating Equation:LOG C =0.8566 x LOG G +0.8977
 Coeff. of Determination (R²):0.9479

MicrotoxOmni Test Report

Date: 07/08/2006 11:54 AM

Test Protocol: 81.9% Basic Test

Sample: Original source 2

Toxicant: -

Reagent Lot no.: -

Test description: Original source 2 (1/1000)

Test name: Original Source 2 shower (1/1000)

Database file: C:\Program Files\MicrotoxOmni\db1.mdb

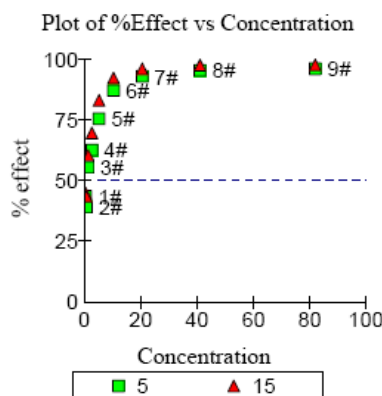
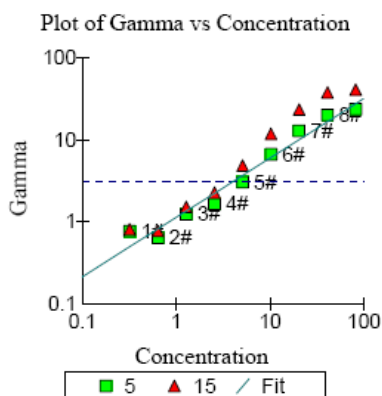

Sample	Conc	5 Mins Data:				15 Mins Data:		
		Io	It	Gamma	% effect	It	Gamma	% effect
Control	0.000	92.96	147.18	1.584 #		143.89	1.549 #	
1	0.3199	152.96	136.95	0.7691 #	43.47%	130.72	0.8120 #	44.81%
2	0.6398	126.60	122.37	0.6387 #	38.98%	110.67	0.7714 #	43.55%
3	1.280	159.59	112.75	1.242 #	55.40%	98.00	1.522 #	60.34%
4	2.559	142.18	84.55	1.664 #	62.46%	67.14	2.279 #	69.51%
5	5.119	145.29	56.71	3.058 #	75.36%	38.18	4.893 #	83.03%
6	10.24	135.08	27.85	6.683 #	86.98%	16.24	11.88 #	92.24%
7	20.48	150.04	17.04	12.95 #	92.83%	9.47	23.53 #	95.92%
8	40.95	154.51	11.52	20.24 #	95.29%	6.13	38.03 #	97.44%
9	81.90	136.61	8.69	23.90 #	95.98%	5.03	41.06 #	97.62%

- used in calculation; * - invalid data; D - deleted from calcs.

Calculations on 5 Mins data:

EC50 Concentration:0.8956% (95% confidence range: 0.5961 to 1.346)

95% Confidence Factor: 1.503

Estimating Equation:LOG C =1.332 x LOG G -0.0478

Coeff. of Determination (R²):0.9673

Slope: 0.7260

Correction Factor: 1.584

Calculations on 15 Mins data:

EC50 Concentration:0.6956% (95% confidence range: 0.4614 to 1.049)

95% Confidence Factor: 1.508

Estimating Equation:LOG C =1.170 x LOG G -0.1576

Coeff. of Determination (R²):0.9711

MicrotoxOmni Test Report

Date: 07/08/2006 05:30 PM

Test Protocol: 81.9% Basic Test
 Sample: Pantene 2 (1/1000)
 Toxicant: -
 Reagent Lot no.: -
 Test description: Pantene shampoo 2 (1/1000)
 Test name: Pantene Pro-V 2 (1/1000) shampoo
 Database file: C:\Program Files\MicrotoxOmni\db1.mdb

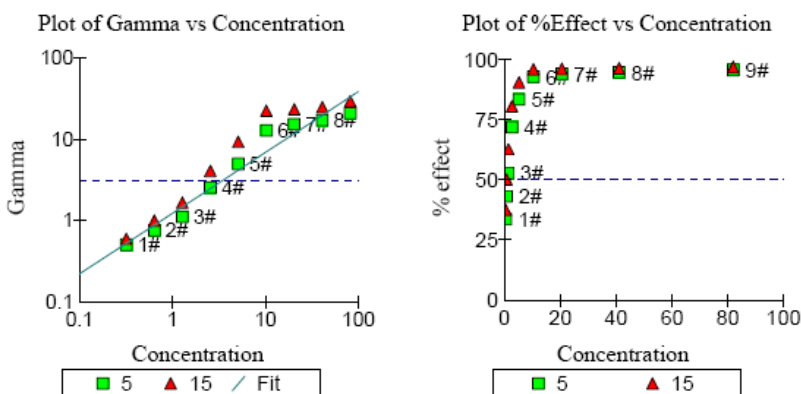

Sample	Conc	5 Mins Data:				15 Mins Data:		
		Io	It	Gamma	% effect	It	Gamma	% effect
Control	0.000	97.21	121.97	1.255 #		121.58	1.251 #	
1	0.3199	114.06	94.96	0.5071 #	33.65%	89.35	0.5966 #	37.37%
2	0.6398	112.64	80.27	0.7607 #	43.20%	70.41	1.001 #	50.02%
3	1.280	108.74	64.44	1.117 #	52.77%	50.80	1.677 #	62.65%
4	2.559	116.63	41.23	2.549 #	71.83%	28.60	4.100 #	80.39%
5	5.119	100.01	20.89	5.007 #	83.35%	12.10	9.337 #	90.33%
6	10.24	134.62	12.16	12.89 #	92.80%	7.12	22.65 #	95.77%
7	20.48	118.39	9.04	15.43 #	93.91%	6.03	23.56 #	95.93%
8	40.95	111.03	7.64	17.23 #	94.52%	5.32	25.10 #	96.17%
9	81.90	118.59	6.75	21.04 #	95.46%	4.85	29.58 #	96.73%

- used in calculation; * - invalid data; D - deleted from calcs.

Calculations on 5 Mins data:
 EC50 Concentration:0.8275% (95% confidence range: 0.4998 to 1.370)
 95% Confidence Factor: 1.656
 Estimating Equation:LOG C =1.272 x LOG G -0.0822
 Coeff. of Determination (R²):0.9525
 Slope: 0.7487
 Correction Factor: 1.255

Calculations on 15 Mins data:
 EC50 Concentration:0.5690% (95% confidence range: 0.2837 to 1.141)
 95% Confidence Factor: 2.006
 Estimating Equation:LOG C =1.196 x LOG G -0.2449
 Coeff. of Determination (R²):0.9279

MicrotoxOmni Test Report

Date: 18/07/2006 05:08 PM

Test Protocol: 81.9% Basic Test
 Sample: persil 2 (1/1000)
 Toxicant: persil fresh 2
 Reagent Lot no.: -
 Test description: persil washing up 2 (1/1000)
 Test name: persil washing up 2 (1/1000)
 Database file: C:\Program Files\MicrotoxOmni\db1.mdb

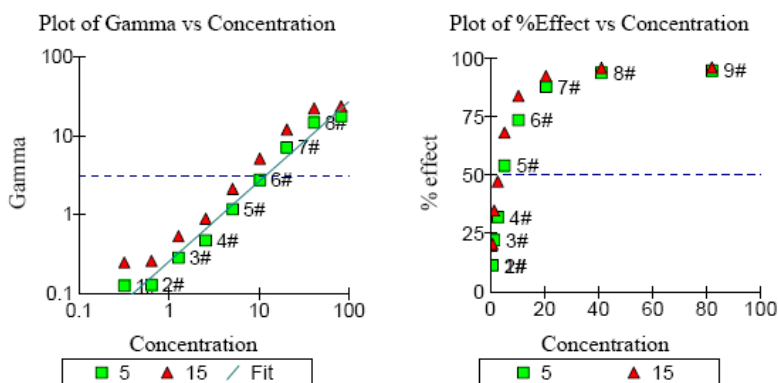

Sample	Conc	5 Mins Data:				15 Mins Data:		
		Io	It	Gamma	% effect	It	Gamma	% effect
Control	0.000	97.05	130.97	1.350 #		133.70	1.378 #	
1	0.3199	96.08	115.22	0.1253 #	11.14%	106.18	0.2466 #	19.78%
2	0.6398	87.19	104.22	0.1290 #	11.43%	95.46	0.2583 #	20.53%
3	1.280	94.56	99.37	0.2842 #	22.13%	85.00	0.5326 #	34.75%
4	2.559	90.46	83.04	0.4701 #	31.98%	65.81	0.8937 #	47.19%
5	5.119	97.25	60.34	1.175 #	54.02%	42.73	2.135 #	68.11%
6	10.24	92.89	33.28	2.767 #	73.45%	20.76	5.164 #	83.78%
7	20.48	97.65	16.16	7.155 #	87.74%	10.33	12.02 #	92.32%
8	40.95	96.91	8.28	14.79 #	93.67%	5.68	22.50 #	95.75%
9	81.90	96.98	7.00	17.70 #	94.65%	5.35	23.97 #	96.00%

- used in calculation; * - invalid data; D - deleted from calcs.

Calculations on 5 Mins data:
 EC50 Concentration: 3.884% (95% confidence range: 3.083 to 4.893)
 95% Confidence Factor: 1.260
 Estimating Equation: LOG C = 0.9643 x LOG G + 0.5893
 Coeff. of Determination (R²): 0.9797
 Slope: 1.016
 Correction Factor: 1.350

Calculations on 15 Mins data:
 EC50 Concentration: 2.137% (95% confidence range: 1.629 to 2.804)
 95% Confidence Factor: 1.312
 Estimating Equation: LOG C = 1.023 x LOG G + 0.3298
 Coeff. of Determination (R²): 0.9768

MicrotoxOmni Test Report

Date: 25/07/2006 12:16 PM

Test Protocol: 81.9% Basic Test

Sample: persil 3 (0.2 g/L)

Toxicant: persil 3 (0.2 g/L)

Reagent Lot no.: -

Test description: persil washing 3

Test name: persil 3 (0.2 g/L)

Database file: C:\Program Files\MicrotoxOmni\db1.mdb

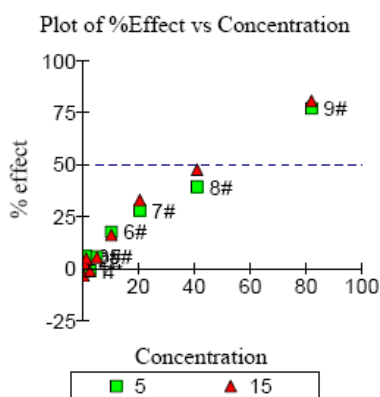
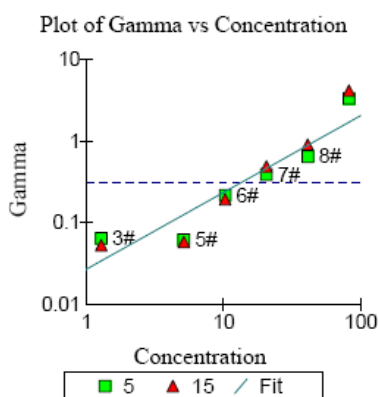

Sample	Conc	5 Mins Data:				15 Mins Data:		
		Io	It	Gamma	% effect	It	Gamma	% effect
Control	0.000	102.96	117.94	1.145 #		115.93	1.126 #	
1	0.3199	99.13	115.09	-0.0133 *	-1.354%	115.36	-0.0324 *	-3.353%
2	0.6398	103.39	113.42	0.0441 *	4.232%	113.49	0.0257 *	2.512%
3	1.280	99.02	106.57	0.0643 #	6.045%	105.87	0.0531 #	5.044%
4	2.559	93.13	107.66	-0.0091 *	-0.9188%	105.94	-0.0101 *	-1.028%
5	5.119	102.65	110.72	0.0620 #	5.838%	109.24	0.0580 #	5.486%
6	10.24	105.04	98.94	0.2161 #	17.77%	99.02	0.1944 #	16.28%
7	20.48	105.08	86.61	0.3898 #	28.05%	79.32	0.4916 #	32.96%
8	40.95	86.75	60.27	0.6488 #	39.35%	51.25	0.9059 #	47.53%
9	81.90	99.64	26.25	3.348 #	77.00%	21.72	4.165 #	80.64%

- used in calculation; * - invalid data; D - deleted from calcs.

Calculations on 5 Mins data:

EC50 Concentration:39.16% (95% confidence range: 15.76 to 97.32)

95% Confidence Factor: 2.485

Estimating Equation:LOG C =0.9226 x LOG G +1.593

Coeff. of Determination (R²):0.8692

Slope: 0.9421

Correction Factor: 1.145

Calculations on 15 Mins data:

EC50 Concentration:33.49% (95% confidence range: 15.90 to 70.55)

95% Confidence Factor: 2.107

Estimating Equation:LOG C =0.8417 x LOG G +1.525

Coeff. of Determination (R²):0.8999

MicrotoxOmni Test Report

Date: 18/07/2006 04:17 PM

Test Protocol: 81.9% Basic Test
 Sample: surcare 2 (1/1000)
 Toxicant: surcare 2 (1/1000)
 Reagent Lot no.: -
 Test description: surcare washing up 2
 Test name: surcare 2 (1/1000)
 Database file: C:\Program Files\MicrotoxOmni\db1.mdb

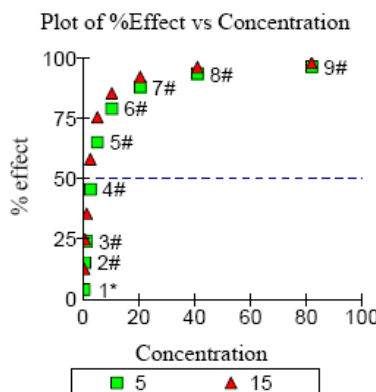
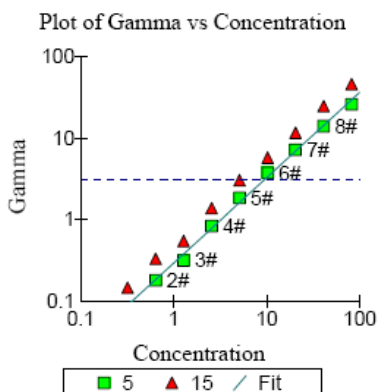

Sample	Conc	5 Mins Data:				15 Mins Data:		
		Io	It	Gamma	% effect	It	Gamma	% effect
Control	0.000	95.63	123.99	1.297 #		121.26	1.268 #	
1	0.3199	81.51	101.28	0.0434 *	4.166%	90.23	0.1455 #	12.70%
2	0.6398	84.57	92.93	0.1799 #	15.25%	80.63	0.3300 #	24.81%
3	1.280	79.38	78.30	0.3144 #	23.92%	64.98	0.5490 #	35.44%
4	2.559	83.07	58.62	0.8373 #	45.57%	44.23	1.382 #	58.01%
5	5.119	94.09	42.71	1.856 #	64.99%	29.43	3.054 #	75.33%
6	10.24	88.55	24.15	3.754 #	78.97%	16.57	5.776 #	85.24%
7	20.48	86.86	13.65	7.250 #	87.88%	8.68	11.69 #	92.12%
8	40.95	91.37	7.82	14.15 #	93.40%	4.47	24.92 #	96.14%
9	81.90	90.53	4.31	26.23 #	96.33%	2.43	46.24 #	97.88%

- used in calculation; * - invalid data; D - deleted from calcs.

Calculations on 5 Mins data:
 EC50 Concentration:3.234% (95% confidence range: 2.892 to 3.617)
 95% Confidence Factor: 1.118
 Estimating Equation:LOG C =0.9494 x LOG G +0.5098
 Coeff. of Determination (R²):0.9961
 Slope: 1.049
 Correction Factor: 1.297

Calculations on 15 Mins data:
 EC50 Concentration:1.960% (95% confidence range: 1.824 to 2.106)
 95% Confidence Factor: 1.075
 Estimating Equation:LOG C =0.9531 x LOG G +0.2922
 Coeff. of Determination (R²):0.9984

MicrotoxOmni Test Report

Date: 02/08/2006 03:30 PM

Test Protocol: 81.9% Basic Test
 Sample: Morrisons bleach 1
 Toxicant: Morrisons bleach 1 (1/5000)
 Reagent Lot no.: -
 Test description: Morrisons Bettabuy bleach
 Test name: Morrisons 1 (1/5000)
 Database file: C:\Program Files\MicrotoxOmni\db1.mdb

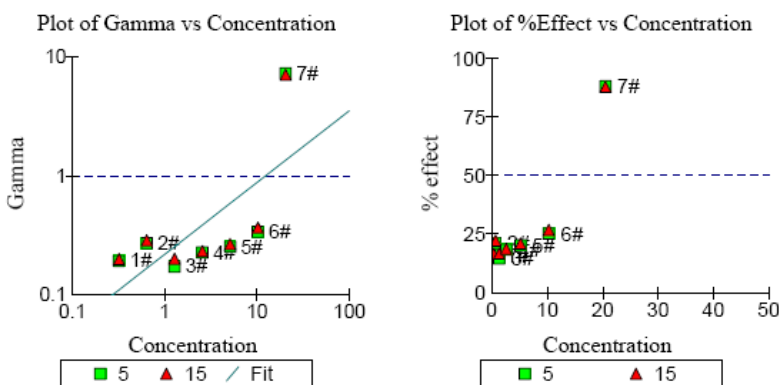

Sample	Conc	5 Mins Data:				15 Mins Data:		
		Io	It	Gamma	% effect	It	Gamma	% effect
Control	0.000	96.64	128.66	1.331 #		119.28	1.234 #	
1	0.3199	113.21	126.50	0.1915 #	16.07%	116.61	0.1983 #	16.55%
2	0.6398	116.65	122.35	0.2693 #	21.22%	112.01	0.2854 #	22.20%
3	1.280	105.42	119.77	0.1718 #	14.66%	108.44	0.1999 #	16.66%
4	2.559	112.62	122.30	0.2260 #	18.43%	112.89	0.2313 #	18.79%
5	5.119	108.69	115.61	0.2516 #	20.11%	106.08	0.2646 #	20.93%
6	10.24	107.49	107.11	0.3361 #	25.15%	97.17	0.3654 #	26.76%
7	20.48	121.55	19.48	7.307 #	87.96%	18.49	7.114 #	87.68%
8	40.95	121.69	0.13	1245 *	99.92%	0.02	7509 *	99.99%
9	81.90	119.50	0.00	- *	-	0.00	- *	-

- used in calculation; * - invalid data; D - deleted from calcs.

Calculations on 5 Mins data:

EC50 Concentration: 5.408% (95% confidence range: 1.244 to 23.51)

95% Confidence Factor: 4.348

Estimating Equation: LOG C = 0.7821 x LOG G + 0.7330

Coeff. of Determination (R²): 0.4735

Slope: 0.6054

Correction Factor: 1.331

Calculations on 15 Mins data:

EC50 Concentration: 5.319% (95% confidence range: 1.256 to 22.53)

95% Confidence Factor: 4.235

Estimating Equation: LOG C = 0.8103 x LOG G + 0.7259

Coeff. of Determination (R²): 0.4808

**Appendix VI:
List of ingredients of products.**

Shampoos:

VO5	Pantene	Morrisons
aqua	aqua	aqua
ammonium laureth sulfate	ammonium laureth sulfate	sodium chloride
ammonium lauryl sulfate	ammonium lauryl sulfate	sodium laureth sulfate
cocamidopropyl betaine	sodium chloride	cocamidopropyl betaine
ammonium chloride	glycol distearate	disodium EDTA
ascorbic acid	dimethicone	parfum
bisabolol panthenol	ammonim xylenesulfonate	citric acid
tocopheryl acetate	citric acid	sodium hydroxyde
biotin	cetyl alcohol	triethylene glycol
niacinamide	sodium citrate	benzyl alcohol
mel (honey extract)	cocamide MEA	propylene glycol
chamomilla recutita flower extract	polyquaternium 10	sodium benzoate
divinyldimethicone/dimethicone copolymer	parfum	magnesium choride
guar hydroxypropyltrimonium chloride	hydrogenated plydecene	magnesium nitrate
sodium cocoyl isethionate	sodium benzoate	methylchloroisothiazolinone
sodium lauroamphoacetate	disodium EDTA	methylisothiazolinone
sodium methyl cocoyl taurate	PEG-7M	hexylene glycol
dipropylene glycol	trimethylolpropane	
bisamino PEG/PPG-41/3 aminoethyl PG-propyl dimethicone quaternium 80	tricaprylate/tricaparte	
propylene glycol	DMDM hydantoin	
pentasodium pentetate	hexyl cinnamal	
sodium xylene sulfonate	tetrasodium EDTA	
citric acid	panthenol	
dimethylpabamidopropyl laurdimonium tosylate	panthenyl ethyl-ether	
polysorbate 20	benzyl salicylate	
C12-13 pareth 23	butyphenyl methylpropional	
C12-13 pareth 3	lysine HCl	
propylene glycol stearate	methyl tyrosinate HCl	
ethoxydiglycol	linalool	
sodium chloride	limonene	
glucose	citronellol	
disodium EDTA	geraniol	
lactic acid	hydroxyisohexyl 3-cyclohexene carboxaldehyde	
butylene glycole	histidine	
hexylene glycol	methylchloroisothiazolinone	
triethanolamine	tocopherol	
DMDM hydantoin	methylisothiazolinone	
imidazolidinyl urea		
methylchloroisothiazolinone		
methylisothiazolinone		
benzyl salicylate		
hexyl cinnamal		
linalool		
parfum		

Shower gels:

Johnson's	Morrison's	Original Source
aqua	aqua	aqua
sodium laureth sulfate	sodium laureth sulfate	sodium laureth sulfate
cocamidopropyl betaine	sodium chloride	cocamide DEA
coco-glucoside	cocamide DEA	mentha arvensis leaf oil
aloe barbadensis	glycerin	melaleuca alternifolia
nelumbo nucifera	cocamidopropyl betaine	sodium chloride
copper gluconate	parfum	PEG-150 distearate
PEG-150 distearate	glycol distearate	sodium lactate
polysorbate 20	cocamide MEA	lauryl betaine
polyquaternium7	laureth 10	disodium EDTA
stearic acid	citric acid	styrene/acrylates copolymer
palmitic acid	benzyl alcohol	sodium lauryl sulfate
propylene glycol	magnesium nitrate	lactic acid
butylene glycol	methylchloroisothiazolinone	lavandula angustifolia oil
sodium chloride	methylisothiazolinone	limonene
tetrasodium EDTA	magnesium chloride	linalool
citric acid	linalool	magnesium nitrate
lactic acid	hexyl cinnamal	methylchloroisothiazolinone
potassium sorbate	butylphenyl methylpropional	methylisothiazolinone
sodium benzoate		magnesium chloride
parfum		

Washing up liquids:

Morrison's	Surcare	Persil
15-30% anionic surfactant	15-30% anionic surfactant	15-30% anionic surfactant
5-15% nonionic surfactant	5-15% nonionic surfactant	less than 5% amphoteric surfactant
less than 5% amphoteric surfactant	less than 5% amphoteric surfactant	perfume
disinfectant	formaldehyde	linalool
formaldehyde		benzisothiazolinone
perfume		citral
2-bromo-2-nitropropane-1, 3-diol		methylchloroisothiazolinone
chloromethylisothiazolone		methylisothiazolinone
methylisothiazolinone		limonene

All purpose cleaner:

Flash	Morrison's	Ecover
less than 5% nonionic surfactant	less than 5% nonionic surfactant	less than 5% plant based nonionic and anionic tension active surfactants
soap	phosphates	soap
glutaral	formaldehyde	natural lemon fragrance
perfume	perfume	
limonene	limonene	

Washing powders:

Persil	Morrisons	Ecover
more than 30% phosphates	more than 30% phosphates	15-30% zeolite and carbonate
15-30% zeolite	15-30% oxygen-based bleaching agent	5-15% nonionic surfactant
5-15% oxygen-based bleaching agent	5-15% anionic surfactant	5-15% anionic surfactant
anionic surfactant	less than 5% nonionic surfactant	soap
nonionic surfactants	perfume	citrate
	hexyl cinnamal	bicarbonate
	brightening agents	less than 5% sulphate
		disilicate
		cellulose derivatives
		magnesium sulphate
		polypeptide
		complexing agent

Bleach:

Nest	Morrisons	Domestos
6% solution hydrogen peroxide	disinfectant	less than 5% chlorine based
		less than 5% bleaching agent
		less than 5% non-ionic surfactants
		soap
		perfume
		limonene