

Technical University of Denmark



## Effects of holding pressure and process temperatures on the mechanical properties of moulded metallic parts

Islam, Aminul; Hansen, Hans Nørgaard; Esteves, N.M.; Rasmussen, T.T.

*Published in:*  
ANTEC 2013 Conference Proceedings

*Publication date:*  
2013

[Link back to DTU Orbit](#)

### *Citation (APA):*

Islam, A., Hansen, H. N., Esteves, N. M., & Rasmussen, T. T. (2013). Effects of holding pressure and process temperatures on the mechanical properties of moulded metallic parts. In ANTEC 2013 Conference Proceedings Society of Plastics Engineers Incorporated (SPE).

## DTU Library

Technical Information Center of Denmark

---

### General rights

Copyright and moral rights for the publications made accessible in the public portal are retained by the authors and/or other copyright owners and it is a condition of accessing publications that users recognise and abide by the legal requirements associated with these rights.

- Users may download and print one copy of any publication from the public portal for the purpose of private study or research.
- You may not further distribute the material or use it for any profit-making activity or commercial gain
- You may freely distribute the URL identifying the publication in the public portal

If you believe that this document breaches copyright please contact us providing details, and we will remove access to the work immediately and investigate your claim.

# EFFECTS OF HOLDING PRESSURE & PROCESS TEMPERATURES ON THE MECHANICAL PROPERTIES OF MOULDED METALLIC PARTS

*A. Islam, H. N. Hansen, N.M. Esteves, T.T. Rasmussen*

*Department of Mechanical Engineering, Technical University of Denmark, Building 427A  
DK-2800 Kgs. Lyngby, Denmark.*

## Abstract

Metal injection moulding is gaining more and more importance over the time and needs more research to be done to understand the sensitivity of process to different process parameters. The current paper makes an attempt to better understand the effects of holding pressure and process temperatures on the moulded metallic parts. Stainless steel 316L is used in the investigation to produce the specimen by metal injection moulding (MIM) and multiple analyses were carried out on samples produced with different combinations of holding pressure, mould temperature and melt temperature. Finally, the parts were characterized to investigate mechanical properties like density, ultimate tensile strength, shrinkage etc. The results are discussed in the paper. The main conclusion from this study is unlike plastic moulding, the tensile properties of MIM parts doesn't vary based on the flow direction of the melt, and tensile properties are sensitive to holding pressure and process temperatures. In order to achieve higher tensile strength, higher holding pressure is required. It was also observed that the samples shrunk more in thickness than in the width and length.

## Introduction

At the current state of molding technologies, metal injection molding (MIM) is an important process for industries that can produce complex shaped metallic parts in mass quantity and at a low price. MIM produces a small amount of waste material because the products are produced near to net shape. Therefore the MIM industry has great prospects in the future, especially in the industries of automotive systems, medical and dental instruments, orthodontics, firearms, computer and electrical applications etc. [1]. Figure 1 shows an example of metal moulded part for the application in a hydraulic pump. The part is called green part after injection moulding and before sintering. The example of moulded green part and sintered final part are shown in the figure below.



Figure 1: Example of moulded metallic parts (Green part-left, and Sintered final part- right)-courtesy of Sintex A/S, Denmark.

Injection moulding of plastic is well described in literature and a huge amount of research has been done on it; on the contrary metal moulding is a rather new field of research, and only a few companies produce MIM parts where the knowhow is not well-spread. The quality of the final parts is influenced by many different factors in each step of the production. Some of these factors are studied and understood but the influence of the holding pressure is not well described and well studied in literature [2]. With this motivation, the current paper investigates on how the processing parameters especially the holding pressure and temperatures can affect the mechanical properties of the MIM parts. The reason to choose process temperatures in combination with holding pressure is the effect of holding pressure is influenced by the freezing of the gate which is dependent on the process temperatures. The shrinkage behaviour of the moulded metallic parts is studied in the paper to know whether they have symmetrical shrinkage in all direction or not. Moreover the uniformity of mechanical properties at different orientations based on the flow direction of the melt is studied.

## Experiments

### Test geometry

The test specimen used for this experiment (shown in Figure 2) was simple flat plate with the dimension of 80×30 mm with 2 mm thickness. The parts were made by

metal injection moulding and used for various investigations.

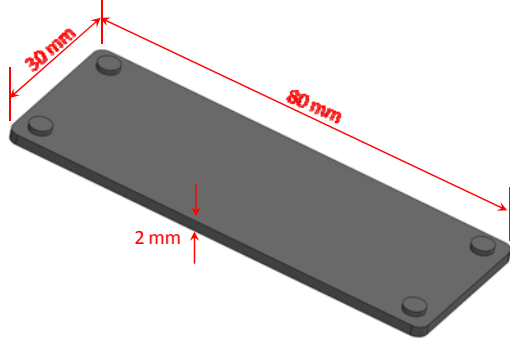

Figure 1: Part geometry used in the experiment.

### Materials used

The material used for this metal injection moulding trial is Catamold® 316L, a ready-to-mould granulates from BASF. After sintering this material can produce parts in stainless steel 316L. Some characteristics of this material according to the supplier’s data sheet [3] are listed in Table 1.

Table 1: Some characteristics of Catamold® 316L A according to the supplier’s data sheet [3].

Density	≥7.75 g/cm <sup>3</sup>						
Tensile strength	≥510 MPa						
Hardness	120 HV						
Metal composition	C %	Cr %	Ni %	Mn%	Mo%	Si %	Fe %
	≤0.03	16-18	10-14	≤2	2-3	≤1	Rest
Yield strength	≥180 MPa						
Particles size	≤20µm						
Polymer	8% polymer (7.2% POM, 0.8% PE)						

The use of POM and PE as binding materials in Catamold, makes the injection moulding easy and provides a simple de-binding step. This material is well-known for non-magnetisable parts with high corrosion resistance and toughness. The material is suitable for watch components, medical equipments and also for parts for food and chemical industries. The standard granulates of Catamold 316L is shown in Figure 3.



Figure 3: Catamold® 316L- a ready-to-mould granulates.

### Moulding machine and process

The moulding machine used for the experiment is presented in the Figure 4. It was an Arburg Allrounder 370A 600-70 Alldrive machine with the clamping force of 1000 kN.



Figure 4: Injection moulding machine used for molding of the metal parts with the binder.

### Experimental plan and sample preparation

The investigation was focused on the effects of holding pressure and the combined effect of holding pressure and temperature on the mechanical properties of the moulded metallic parts. Besides these some other issues like shrinkage of the parts, uniformity in the mechanical properties etc. were investigated. The moulded specimens were made to fulfill the above-mentioned experimental plans. Table 2 lists the important process parameters of the moulding trial. At the beginning the parts were moulded with standard processes conditions recommended by the material manufacture. Then the standard conditions were combined with two different holding pressures (1200 and 1600 Bar) to know the effects of increasing holding pressure on the properties of the moulded metallic parts. Furthermore, a higher temperature setting was used combined with low and high (900 and 1600 Bar) holding pressure to know the combined effects of temperature and holding pressure on the MIM parts.

Table 2: List of important process parameters used for the moulding of the green parts.

Standard process condition				
Barrel temperatures	160°C	170°C	180°C	190°C
Mould temperature	125°C			
Holding pressure	900 Bar			
Variable holding pressure	1200/1600 Bar			
With high process temperature				

Barrel temperature profile	170°C	180°C	190°C	200°C
Mould temperature	140°C			
Holding pressure	900, 1600 Bar			

The moulded parts with different combinations of process conditions are shown in Figure 5.



Figure 5: Injection moulded specimen with different moulding conditions.

### Debinding and sintering conditions

The debinding and sintering processes were performed at Sintex A/S, sited in Hobro, Jutland, Denmark. The debinding was done in a nitrogen atmosphere at 130°C, where nitric acid was added as a catalyst to react with the POM forming formaldehyde. This mix was then burned out to remove the formaldehyde.

The sintering was performed in hydrogen atmosphere at 1350°C. For debinding and sintering the parts were placed on top of a ceramic  $Al_2O_3$  plate to ensure that no major diffusion occurred, which would cause the migration of the alloy elements between the sample and the supporting plate. The entire debinding and sintering processes took 36 hours to be completed. Figure 6 schematically represents the layout for sintering process. Temperature oscillation in the chamber was within  $\pm 3^\circ C$ .

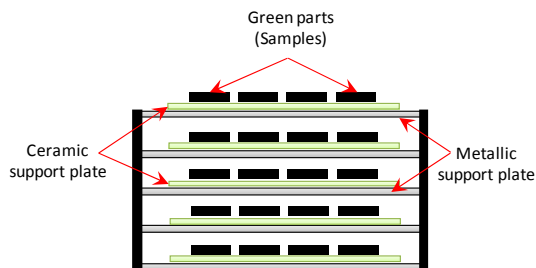

Figure 6: Schematic representations of stacks of green parts inside the chamber for debinding and sintering.

### Result and analysis

To observe the microstructural change in the green parts and in the sintered parts some pictures were taken on both types of parts by Scanning Electron Microscope. Figure 7 shows the part before sintering and after sintering. The non-sintered part shows the distribution of metal particles which is not uniform. The sintered part shows the grain boundary clearly and some black spots are visible in the part that represents the voids in the samples. The magnified view of the non-sintered samples also shows unsymmetrical size and shape of the metal particles and the non-uniformity in the distribution.

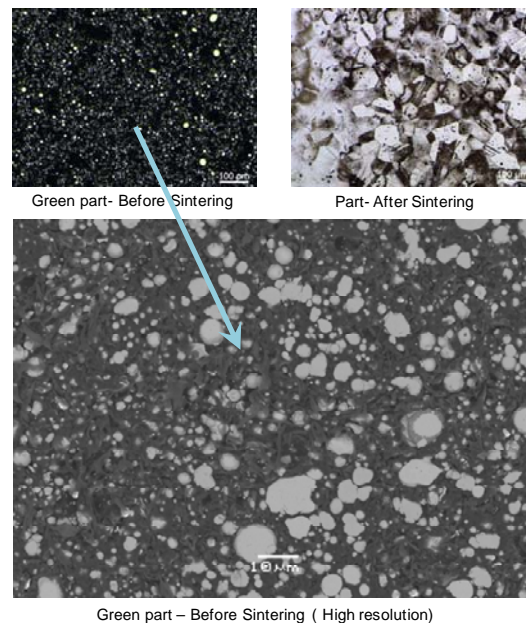

Figure 7: Scanning Electron micrograph of moulded metal part- before and after sintering.

It can be taken as a general rule for moulding that the more homogeneous the structure is, the more favourable the mechanical behaviour will be [4]. To get uniform mechanical properties in the MIM part it is necessary to make sure that the powder metal has the same grain size and shape moreover it is also necessary to make sure that the distribution of the metal particles inside the polymer matrix is uniform during the moulding process.

One of the well-known challenges in MIM is the shrinkage phenomenon occurring during sintering of the part. The green parts are highly porous, and during the sintering process this porosity is reduced which causes a large shrinkage in the part. For this reason, the MIM mould is designed with larger dimensions than the ones intended for the final product. The typical value mentioned in the supplier's product specification for Catamold is 1.1669. In plastic injection moulding the parts, shrink most in the direction parallel to the melt flow. For MIM, the shrinkage should be uniform in all directions at least according to the theory [5]. This was



verified by the current investigation. Figure 8 shows the reduction of dimension of the sintered part compared to green part in the experimental case.

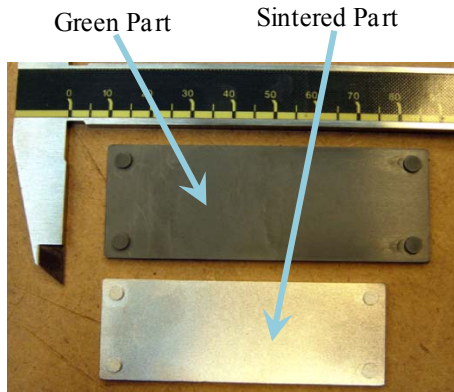

Figure 8: Shrinkage resulting from sintering (non-sintered sample on top, sintered sample below).

To make a comparison the length, width & thickness of the green parts and sintered parts were measured. For the verification purpose, five samples were measured from the group of different process condition. The results from the shrinkage measurement are plotted in Figure 9.

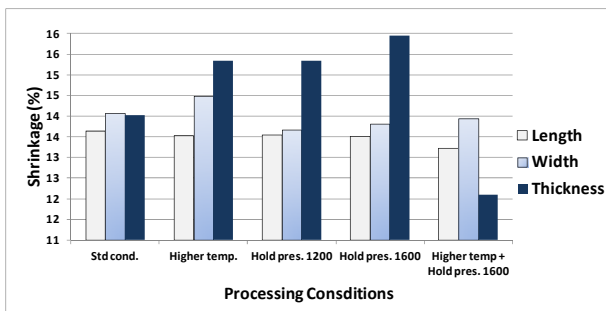

Figure 9: Shrinkage of sintered parts in length, width and thickness.

The result shows that the increasing of holding pressure alone could not decrease the shrinkage of the part. However, the combination of higher holding pressure and higher temperature settings (mould and melt temperature) can produce parts with less shrinkage compared with the parts produced with standard process conditions. It is also clearly observed from the plot that there is tendency to shrink more in the thickness direction compared with the other two directions. The standard deviations of the geometrical measurements are extremely small and that suggest that there is something else responsible for this behavior. According to the authors understanding, the main reason for the increased thickness shrinkage is the gravity. The metal particles are very heavy and during the sintering process heavy metal particles acts towards the gravity pull and reduce the part dimension more in the

thickness direction. The friction between the sample and support plate could also have some influence on this shrinkage phenomena. Because, in length and width direction the part is restricted due to the friction with the supporting surface. On the other hand, the part is free to move on the direction of thickness and that facilitate the shrinkages in thickness.

Another important issue for the sintered part is the density. One of the challenges in sintering is to achieve higher density of the part. To investigate on the density of experimental parts, five samples were randomly selected from each batch of process conditions. These selected samples were weighted at the same time on a scale measuring with a precision down to 0.001 g. Then the weight has been divided by five to obtain the average mass of one sample. The density of the parts were obtained by dividing the mass by the volume of the part. The results of the density measurement are presented in Figure 10.

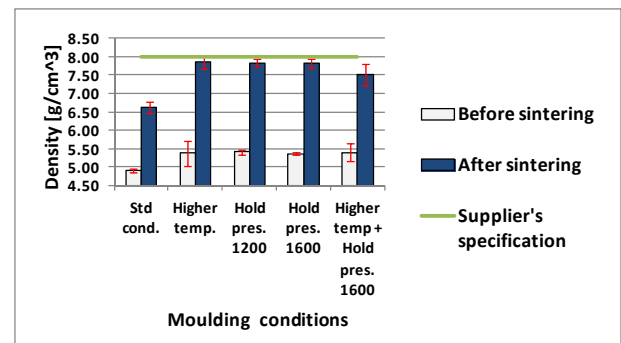

Figure 10: Density of sintered and no-sintered samples in comparison with the reference value.

Here, it is obvious that the density values increase substantially after sintering. The results indicate that a low density of the green parts results in a low density of sintered part. In addition, the samples moulded at higher temperatures have higher density before sintering thus achieving a higher density after sintering. A similar conclusion can be taken for the holding pressure settings of Figure 10. A higher holding pressure can contribute to the increased density of the parts. It is also clear from the result that the density of the sintered part is always less than the reference value or the density specification given by the material supplier.

One of the main objectives of the experiment was to verify the uniformity of the ultimate tensile strength (UTS) in both the parallel and the perpendicular direction to the melt flow. For the investigation, multiple specimens were cut from the sintered parts, both in longitudinal and perpendicular directions. Each of these specimens was

then subjected to a tension load at a rate of 2 mm per second until fracture (Figure 11).

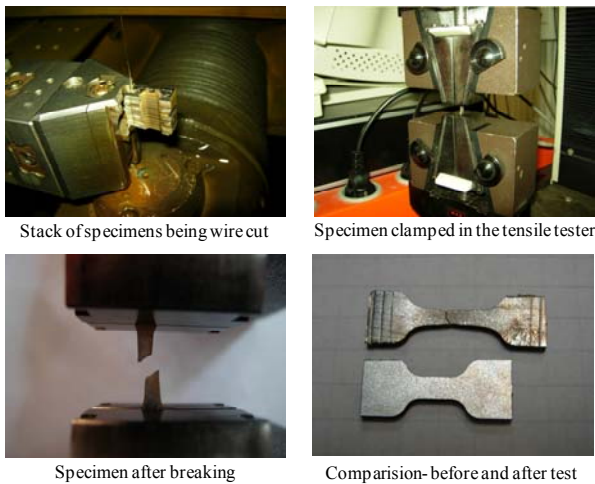

Figure 11: Ultimate tensile strength measurement of sintered specimen.

The average values of the UTS of four groups of specimens moulded with different process condition and cut in longitudinal and perpendicularly direction are plotted in the figure below.

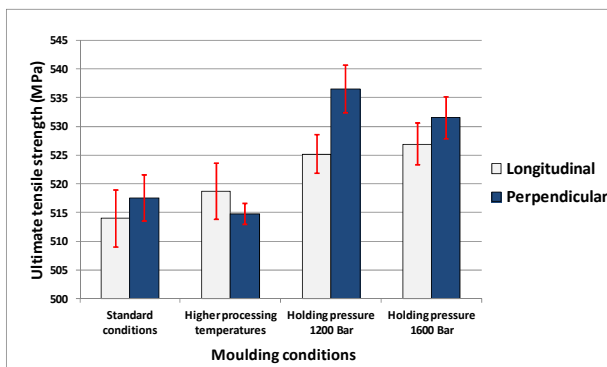

Figure 12: Ultimate tensile strength values for the different moulding conditions (specimens cut from the area close to gate).

The main conclusion drawn from the plot above is, there is no significant difference in the UTS based on melt flow during the moulding process. The tensile property of the parts is the same parallel to the flow and perpendicular to the flow. It also shows that holding pressure has a significant influence on the tensile strength of the moulded metallic parts. It is clear from the results that the higher holding pressure can give higher tensile strength to the parts due to the better packing and better density of the part.

## Summary and conclusion

This paper investigates on the mechanical properties of moulded metallic parts based on different holding pressures & moulding temperatures. For all combinations of the processing conditions, the samples shrunk more in thickness than in the width and length. This is believed to be caused by gravity and friction between sample and supporting surface.

It was observed that the holding pressure can affect the ultimate tensile strength of the moulded metallic parts. The density of the non-sintered part increases when either pressure or temperature is increased. To achieve high UTS higher holding pressure and processing temperatures during the injection moulding are required. By microscopic investigation large pores were observed near the surface of the part, whereas the bulk had a fine distribution of smaller pores which could make non symmetrical mechanical properties at different layer thickness of the part. This issue was not investigated in details in the current paper and a make scope for future investigation.

## References

1. "How It Works – Metal Injection Molding", *Today's Machining World Archive: August 2007, Vol. 3, Issue 03*, August 2007.
2. C. Petera, "The influence of holding pressure on powder distribution in PIM technology", Technical University of Liberec, Faculty of Mechanical Engineering, Czech Republic. *MM Science Journal* 326-329, July 2012.
3. BASF, "Product specification Catamold 316L," 2009.
4. F. Johannaber, "Injection Molding Machines: A User's Guide", Publisher: Hanser, ISBN: 978-1-56990-418.
5. G. Schlieper, G. Dowson and F. Petzoldt, "Metal Injection Molding - process, properties and testing, technical guidelines, MIM design, case studies, standards," European Powder Metallurgy Association, Shrewsbury, 2000.

**Key words:** Metal Injection moulding, Holding pressure, Mechanical properties.