



Designing Trailing Edge Flaps of Wind Turbines using an Integrated Design Approach

Mirzaei, Mahmood; Poulsen, Niels Kjølstad; Niemann, Hans Henrik

Publication date:
2012

[Link back to DTU Orbit](#)

Citation (APA):

Mirzaei, M., Poulsen, N. K., & Niemann, H. H. (2012). Designing Trailing Edge Flaps of Wind Turbines using an Integrated Design Approach. Paper presented at 10th European Workshop on Advanced Control and Diagnosis, Kgs. Lyngby, Denmark.

DTU Library

Technical Information Center of Denmark

General rights

Copyright and moral rights for the publications made accessible in the public portal are retained by the authors and/or other copyright owners and it is a condition of accessing publications that users recognise and abide by the legal requirements associated with these rights.

- Users may download and print one copy of any publication from the public portal for the purpose of private study or research.
- You may not further distribute the material or use it for any profit-making activity or commercial gain
- You may freely distribute the URL identifying the publication in the public portal

If you believe that this document breaches copyright please contact us providing details, and we will remove access to the work immediately and investigate your claim.

Designing Trailing Edge Flaps of Wind Turbines using an Integrated Design Approach

Mahmood Mirzaei* Niels Kjølstad Poulsen*
Hans Henrik Niemann**

* *Department of Informatics and Mathematical Modeling, Technical University of Denmark, Denmark, (e-mail: mmir@imm.dtu.dk, nkp@imm.dtu.dk).*

** *Department of Electrical Engineering, Technical University of Denmark, Denmark, (e-mail: hhn@elektro.dtu.dk)*

Abstract: In this paper designing a controller for trailing edge flaps (TEF) as well as optimizing its position on the wind turbine blade will be considered. An integrated design approach will be used to optimize both TEF placement and controller simultaneously. Youla parameterization will be used to parameterize the controller and the plant. The goal is to maximize blade root bending moments while minimizing actuator activity. An optimization with linear matrix inequalities (LMI) constraints will be used to optimize the \mathcal{H}_∞ norm of the system.

Keywords: Wind turbines, trailing edge flaps, integrated design, Youla parameterization

1. INTRODUCTION

In recent decades there has been increasing interest in green energies of which wind energy is one of the most important. Wind turbines are the most common wind energy conversion systems (WECS) and are hoped to be able to compete with fossil fuel power plants on energy price in the near future. However this demands better technology to reduce the electricity production price. One way to decrease the electricity production price is to reduce structural fatigue and therefore increase the lifetime of the wind turbine. Recent studies have shown that employing trailing edge flaps on wind turbine blades can decrease fatigue loads on the blades. There have been several research in this area tackling the problem of designing trailing edge flaps (Andersen, 2010), (Castaignet et al., 2011) and (). In this paper we try to design trailing edge flaps for a wind turbine using an integrated design approach where we optimize the flap radial position on the blade and also its length while optimizing the controller. In order to formulate the integrated design problem we parameterize the plant and the controller using Youla parameterization (Tay et al., 1998). The paper is organized as follows: In section 2.1 the problem will be stated and design objectives will be given. In section 2.2 controller parameterization and optimization will be discussed and finally in section 2.3 plant parameterization and optimization will be given.

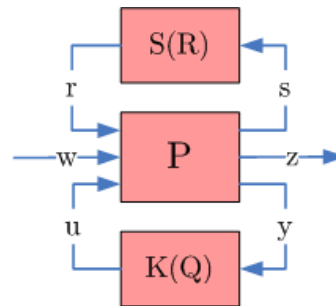

Fig. 1. Plant and controller parameterized

2. PROPOSED INTEGRATED DESIGN METHOD

2.1 Problem formulation and design objectives

We want to optimize plant and controller parameters together in the design process. One way to make the problem solvable is to formulate two different optimization problems and solve them iteratively. We start with an initial guess, then firstly we optimize controller parameters given a fixed plant model and then we optimize plant parameters, given a fixed controller. To do so, consider figure 1. In this figure input output relationships could be written as:

$$\begin{pmatrix} s \\ z \\ y \end{pmatrix} = \begin{pmatrix} P_{11} & P_{12} & P_{13} \\ P_{21} & P_{22} & P_{23} \\ P_{31} & P_{32} & P_{33} \end{pmatrix} \begin{pmatrix} r \\ w \\ u \end{pmatrix} \quad (1)$$

$$r = S(R)s \quad (2)$$

$$u = K(Q)y \quad (3)$$

In which $S(R)$ is used to denote parameters of the plant as the transfer function R and $K(Q)$ is used to denote parameters of the controller as the transfer function Q . Having this, the integrated design problem can be cast

* This work is supported by the CASED Project funded by grant DSF-09- 063197 of the Danish Council for Strategic Research.

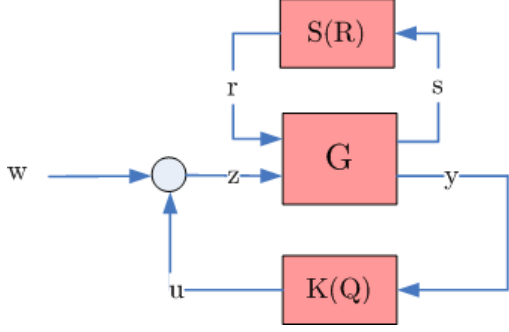

Fig. 2. Integrated design for a SISO system into the following optimization problem:

$$\min_{Q,R} \|\mathcal{H}_{zw}\|_{\infty} \quad (4)$$

In which we try to minimize the \mathcal{H}_{∞} norm of the transfer function \mathcal{H}_{zw} from disturbance w to exogenous output z . To do so, we can iterate between optimizing the plant and the controller, which are:

$$\mathcal{H}_{zw}^P = F_u(F_l(P, K(Q)), S(R)) \quad (5)$$

$$\mathcal{H}_{zw}^C = F_l(F_u(P, S(R)), K(Q)) \quad (6)$$

F_l and F_u denote lower and upper linear fractional transformations (LFT) respectively. Therefore the optimization algorithm becomes:

- Step 1: Optimize controller parameters

$$\min_Q \|\mathcal{H}_{zw}\|_{\infty} \quad (7)$$

- Step 2: Optimize plant parameters

$$\min_R \|\mathcal{H}_{zw}\|_{\infty} \quad (8)$$

- Step 3: Check termination conditions, if satisfied terminate else go to step 1.

We start by defining a simple SISO example. The system interconnection is shown in figure 2.

2.2 Controller Optimization

Controller Parameterization Having a plant model (either from a first guess or result of an optimization), we are now in a position that we can optimize the controller. To do so we start by writing down the transfer matrix for the system with disturbances and input/output.

$$\begin{pmatrix} z \\ y \end{pmatrix} = \begin{pmatrix} C_{11} & C_{12} \\ C_{21} & C_{22} \end{pmatrix} \begin{pmatrix} w \\ u \end{pmatrix} \quad (9)$$

Therefore the transfer function from w to z becomes:

$$\mathcal{H}_{zw}^C = C_{11} + C_{12}K(1 - KC_{22})C_{21} \quad (10)$$

Now if we parameterize the controller K using Youla parameterization as:

$$K = \frac{U_q + N_q Q}{V_q + M_q Q} \quad (11)$$

In which U_q, V_q, N_q and M_q are calculated by coprime factorization of C_{22} :

$$C_{22} = G_{22} + G_{21}(1 - SG_{11})^{-1}SG_{12} \quad (12)$$

$$C_{22} = N_q M_q^{-1} \quad (13)$$

And solving the following Bezout equation:

$$N_q U_q + M_q V_q = 1 \quad (14)$$

Using the parameterization given in (11), the transfer function \mathcal{H}_{zw}^C could be written as:

$$\mathcal{H}_{zw}^C = C_{11} + C_{12}QC_{21} \quad (15)$$

For a SISO system given in figure 2, we know C_{11}, C_{12}, C_{21} and C_{22} are:

$$C_{11} = 1 \quad (16)$$

$$C_{12} = 1 \quad (17)$$

$$C_{21} = G_{22} + G_{21}(1 - SG_{11})^{-1}SG_{12} \quad (18)$$

Coprime factorization of state space models After formulating the transfer functions from w to z for parameterized controller as follows:

$$\mathcal{H}_{zw}^C = C_{11} + C_{12}QC_{21}$$

Now it is time to find coprime factorization of C_{22} . One way to do this, is to first find a state space realization of it which we denote as:

$$C_{22} = \begin{pmatrix} A_c & B_c \\ C_c & D_c \end{pmatrix}$$

Next step is to calculate normalized coprime factorization of this transfer functions which can be calculated by the following formula (Vidyasagar, 1987): For a state space realization of $G(s)$ normalized coprime factorization of G is:

$$(N_l(s) \ M_l(s)) \stackrel{s}{=} \begin{pmatrix} A + HC & B + HD & H \\ R^{-1/2}C & R^{-1/2}D & R^{-1/2} \end{pmatrix}$$

Where:

$$H \triangleq -(BD^T + ZC^T), \quad Z \triangleq I + DD^T$$

In which Z is the solution to the following algebraic Riccati equation:

$$(A - BS^{-1}D^T C)Z + Z(A - BS^{-1}D^T C)^T - ZC^T R^{-1}CZ + BS^{-1}B^T = 0$$

In which:

$$S \triangleq I - D^T D$$

Another way is to design a stabilizing controller, e.g. using LQG theory (Doyle et al., 1992), and then use that controller and coprime factorization of the plant to parameterize all the stabilizing controllers. For the transfer function C_{22} we have a state space realization as:

$$C_{22} = \begin{pmatrix} A & B \\ C & D \end{pmatrix}$$

And we need to find state space realizations for N, M, X and Y such that we have:

$$C_{22} = \frac{N}{M}, \quad NX + MY = 1$$

We do not go into the details here and give the final transfer functions in terms of state space matrices of a realization of the transfer function C_{22} and matrices F and H are found such that $A + BF$ and $A + HC$ are stable, found for example using LQG method.

$$M(s) = \begin{pmatrix} A + BF & B \\ F & 1 \end{pmatrix} \quad N(s) = \begin{pmatrix} A + BF & B \\ C + DF & D \end{pmatrix}$$

$$X(s) = \begin{pmatrix} A + HC & H \\ F & 0 \end{pmatrix} \quad Y(s) = \begin{pmatrix} A + HC & -B - HD \\ F & 1 \end{pmatrix}$$

Optimization problem So far we have formulated the optimization problem of the form:

$$\text{Controller optimization: } \min_Q \|\mathcal{H}_{zw}^C\|_{\infty} \quad (19)$$

Knowing that \mathcal{H}_{zw}^C is an affine functions of Q (see equation (15)), now we proceed to formulate and solve an optimization problem of the form given below, which is the optimization problem (19) after parameterization.

$$\min_{X(s) \in \mathcal{RH}_\infty} \|Y_0(s) + Y_1(s)X(s)Y_2(s)\|_\infty \quad (20)$$

$X(s)$ is a transfer function which is in infinite dimensional \mathcal{RH}_∞ . However in order to be able to solve the optimization problem we approximate the solution with a finite dimensional parameterized transfer function of the form:

$$X(s) = \sum_{i=1}^{n_q} \alpha_i X_i(s) \quad (21)$$

In which for example we formulate X_i 's as:

$$X_i = \frac{\sqrt{2a}}{s+1} \left(\frac{s-a}{s+a} \right)^{i-1} \quad (22)$$

we are optimizing only the parameters α_i in the transfer function $X(s)$, therefore we can write:

$$X(s) = \left(\begin{array}{c|c} A_x & B_x \\ \hline C_x(\alpha) & D_x(\alpha) \end{array} \right) \quad (23)$$

In order to simplify, the transfer function given in (20) can be written as (knowing it is a SISO system):

$$Y(s) = Y_0(s) + Y_1(s)X(s)Y_2(s) \quad (24)$$

$$= Y_0(s) + Y_1(s)X(s) \quad (25)$$

In which we have replaced $Y_1(s)Y_2(s)$ with $Y_1(s)$.

LMI formulation For minimizing \mathcal{H}_∞ norm of a transfer function, having its state space realization we can solve the following optimization problem:

$$\min \gamma \quad (26)$$

$$\begin{pmatrix} A_y^T P + P A_y & P B_y & C_y^T \\ \star & -\gamma I & D_y^T \\ \star & \star & -\gamma I \end{pmatrix} \prec 0 \quad (27)$$

$$P \succ 0 \quad (28)$$

In which:

$$Y(s) = \left(\begin{array}{c|c} A_y & B_y \\ \hline C_y & D_y \end{array} \right) \quad (29)$$

Now we need to find the state space realization of $Y(s)$ parameterized in terms of parameters of the transfer function $X(s)$. And for that matter we use the following equations:

$$W_1 + W_2 = \left(\begin{array}{cc|c} A_1 & 0 & B_1 \\ 0 & A_2 & B_2 \\ \hline C_1 & C_2 & D_1 + D_2 \end{array} \right) \quad (30)$$

$$W_1 W_2 = \left(\begin{array}{cc|c} A_1 & B_1 C_2 & B_1 D_2 \\ 0 & A_2 & B_2 \\ \hline C_1 & D_1 C_2 & D_1 D_2 \end{array} \right) \quad (31)$$

Therefore we have:

$$Y(s) = Y_0(s) + Y_1(s)X(s) \quad (32)$$

$$= \left(\begin{array}{c|c} A_0 & B_0 \\ \hline C_0 & D_0 \end{array} \right) + \left(\begin{array}{c|c} A_1 & B_1 \\ \hline C_1 & D_1 \end{array} \right) \left(\begin{array}{c|c} A_x & B_x \\ \hline C_x(\alpha) & D_x(\alpha) \end{array} \right) \quad (33)$$

$$= \left(\begin{array}{cc|c} A_0 & B_0 & B_x D_1 \\ \hline C_0 & D_0 & C_1 D_x(\alpha) \end{array} \right) + \left(\begin{array}{cc|c} A_x & B_x C_1 & B_x D_1 \\ 0 & A_1 & B_1 \\ \hline C_x(\alpha) & D_x(\alpha) C_1 & D_x(\alpha) D_1 \end{array} \right) \quad (34)$$

$$= \left(\begin{array}{ccc|c} A_0 & 0 & 0 & B_0 \\ 0 & A_x & B_x C_1 & B_x D_1 \\ 0 & 0 & A_1 & B_1 \\ \hline C_0 & C_x(\alpha) & D_x(\alpha) C_1 & D_0 + D_x(\alpha) D_1 \end{array} \right) \quad (35)$$

And then we get the following matrices for the LMI optimization.

$$A_y = \begin{pmatrix} A_0 & 0 & 0 \\ 0 & A_x & B_x C_1 \\ 0 & 0 & A_1 \end{pmatrix} \quad B_y = \begin{pmatrix} B_0 \\ B_x D_1 \\ B_1 \end{pmatrix} \quad (36)$$

$$C_y(\alpha) = (C_0 \ C_x(\alpha) \ D_x(\alpha) C_1) \quad D_y(\alpha) = D_0 + D_x(\alpha) D_1 \quad (37)$$

2.3 Plant Optimization

A set of linearized transfer functions for a trailing edge flap can be found using system identification. The set could be written as:

$$H(s) = \frac{(s + z_1(r, d))(s + z_2(r, d))}{(s + p_1(r, d))(s + p_2(r, d))} \quad (38)$$

In which r is the distance from the root of the blade and determines TEF placement and d determines the size of the TEF. The equation (38) shows that poles and zeros of the TEF are functions of r and d and we can determine these functions by running a number of experiments with different values of r and d , and using system identification to find poles and zeros of the transfer function. The goal is to solve the following optimization problem:

$$\text{Plant optimization:} \quad \min_{r,d} \|\mathcal{H}_z^P w\|_\infty$$

REFERENCES

- Andersen, P.B. (2010). *Advanced Load Alleviation for Wind Turbines using Adaptive Trailing Edge Flaps: Sensing and Control*. Ph.D. thesis, Technical University of Denmark, Denmark.
- Castagnet, D., Poulsen, N.K., Buhl, T., and Wedel-Heinen, J.J. (2011). Model predictive control of trailing edge flaps on a wind turbine blade. *Proceedings of the American Control Conference*, 4398–4403.
- Doyle, J., Francis, B., and Tannenbaum, A. (1992). *Feedback Control Theory*. Macmillan Publishing Company, New York, N.Y.
- Panofsky, H.A. and Dutton, J.A. (????). *Atmospheric turbulence: Models and methods for engineering applications*.
- Tay, T.T., Mareels, I., and Moore, J. (1998). *High performance control*. Birkhauser, Boston.
- Vidyasagar, M. (1987). *Control system synthesis / A factorization approach*. MIT Press, Cambridge, Mass.