



## Udvikling af CO2 neutralt byrumsarmatur

### Slutrapport

**Poulsen, Peter Behrendorff; Dam-Hansen, Carsten; Corell, Dennis Dan; Thorseth, Anders; Thorsteinsson, Sune; Hansen, Søren Stentoft; Wolff, Jesper; Ellermann, Stine; Bak, Christian; Skrzypinski, Witold Robert; Beller, Christina; Kock, Carsten Weber; Bühler, Fabian; Harboe, René Kirstein; Boesgaard, Per; Jensen, Tim; Søndergaard, Ole; Andresen, Christian; Fahlén, Morten; Maare, Thomas; Prestegaard, Hugo; Poulsen, Jan; Kremmer, Susanne**

*Publication date:*  
2013

*Document Version*  
Publisher's PDF, also known as Version of record

[Link back to DTU Orbit](#)

*Citation (APA):*  
Poulsen, P. B., Dam-Hansen, C., Corell, D. D., Thorseth, A., Thorsteinsson, S., Hansen, S. S., ... Kremmer, S. (2013). Udvikling af CO2 neutralt byrumsarmatur: Slutrapport. *Elforsk*.

## DTU Library

Technical Information Center of Denmark

---

### General rights

Copyright and moral rights for the publications made accessible in the public portal are retained by the authors and/or other copyright owners and it is a condition of accessing publications that users recognise and abide by the legal requirements associated with these rights.

- Users may download and print one copy of any publication from the public portal for the purpose of private study or research.
- You may not further distribute the material or use it for any profit-making activity or commercial gain
- You may freely distribute the URL identifying the publication in the public portal

If you believe that this document breaches copyright please contact us providing details, and we will remove access to the work immediately and investigate your claim.

# Udvikling af CO2 neutralt byrumsarmatur

Slutrapport  
PSO 343-021



## Udarbejdet af:

*Peter Behrendorff Poulsen, Carsten Dam-Hansen, Dennis Corell, Anders Thorseth, Sune Thorsteinsson, Søren Stentoft  
Hansen, Jesper Wolff, Stine Ellermann, DTU Fotonik  
Christian Bak, Witold Skrzypiński, Christina Beller, Carsten Weber Kock, DTU Wind Energy  
Fabian Bühler, René Kirstein Harboe, Faktor 3 ApS  
Per Boesgaard, Gate 21  
Tim Jensen, Philips Lighting  
Ole Søndergaard, Alfred Priess  
Christian Andresen, Henning Larsens Architects  
Morten Fahlén, Dong Energy  
Thomas Maare, Hugo Prestegaard, Copenhagen Municipality  
Jan Poulsen, Egedal Municipality  
Susanne Kremmer, Albertslund Municipality*

Projektet er støttet under ELFORSK programmet og har her i projektnummer 343-021 "udvikling af CO2 neutralt byrumsarmatur"

## FORORD

Denne rapport indeholder en beskrivelse af arbejdet udført i og resultaterne af forsknings- og udviklingsprojektet "Udvikling af CO2 neutralt byrumsarmatur" og udgør slutrapportering for dette projekt.

Projektet er gennemført i et samarbejde imellem følgende partnere:

- Gate 21
- DTU Fotonik
- DTU Vind
- ark-unika
- Philips Lighting
- Faktor-3
- Alfred Priess
- Henning Larsens Tegnastue
- Dong Energy
- Københavns Kommune
- Albertslund Kommune
- Egedal Kommune

Projektet har været under ledelse af

### **Gate 21**

Projektleder, Per Boesgaard  
Vognporten 2  
2620 Albertslund  
CVR-nr.: 32112846

Projektet er finansieret af Dansk Energi under ELFORSK's PSO program, indsatsområde 3a. LED belysning. Projektet har projekt nr. PSO 343-021, og blev startet i januar 2011 og er afsluttet i marts 2013.

I rapportens første del gives et kortfattet resumé af projektet og dets resultater, herunder baggrunden for og formålet med projektet, hovedresultaterne samt konklusioner og perspektiverne af projektets resultater. En udførlig rapportering af projektarbejdet i detaljer og resultaterne følgende heraf og konklusionerne herpå er givet efterfølgende. Til sidst følger liste med den formidlingsaktivitet projektet har udsprunget i.

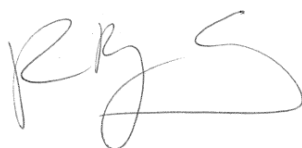

*Per Boesgaard*

*Gate 21, Albertslund, 31. marts 2013.*

## PREFACE

This report contains a description of the work carried out and the results of the research and development project: "Development of a carbon neutral luminaire for the urban environment" and form the final report for this project.

The project is carried out in cooperation between the following partners:

- Gate 21
- DTU Fotonik
- DTU Vind
- ark-unika
- Philips Lighting
- Faktor-3
- Alfred Priess
- Henning Larsens Tegnestue
- Dong Energy
- Københavns Kommune
- Albertslund Kommune
- Egedal Kommune

The project has been led by:

### **Gate 21**

Project Manager, Per Boesgaard  
Vognporten 2  
2620 Albertslund  
CVR-nr.: 32112846

The project is financed by the Danish Energy Association through ELFORSK's PSO program, under 3a. LED illumination and 7b. Marking and efficiency demands. The project has no. PSO 343-021 and was initiated in January 2011 and was ended in March 2013.

In the first part of the report a short resume of the project is given, describing the background and aim of the project, the work and results together with future perspectives of the results of the project. A detailed report of the project work and the results following hereof and the conclusions are given below. Finally, the work on communicating the results of the project are described.

## 1. TABLE OF CONTENTS

Forord .....	2
Preface .....	3
2. Dansk Resumé .....	6
2.1. Baggrund .....	6
2.2. Formål .....	6
2.3. Resultater Konklusioner og perspektiver .....	6
3. Introduction .....	9
4. What is a hybrid system .....	11
5. Theory .....	12
5.1. Light .....	12
5.2. Sun .....	13
5.3. Wind .....	14
5.4. Storage .....	15
6. Technologies .....	16
6.1. Light .....	16
6.2. PV .....	19
6.3. Wind .....	20
6.4. Battery .....	25
7. Street lighting .....	26
7.1. Street lighting in Copenhagen .....	26
7.2. Danish regulation for street and road lighting .....	28
8. Market study of commercial hybrid systems .....	33
8.1. Commercial hybrid systems today .....	33
8.2. Data .....	36
8.3. Analysis .....	37
9. Implementation of 4 hybrid systems at RISØ Campus .....	45
9.1. installation of the commercial hybrid system for test and benchmarking .....	45
9.2. Data logging .....	47
10. Mathematical model system of hybrid systems .....	48
10.1. Description of the model .....	48
10.2. Modeling the urban wind climate .....	49
10.3. Modeling the wind turbine .....	49
10.4. Modelling the lighting .....	51
10.5. Modeling the PV panel .....	52
10.6. Modeling the battery .....	54
10.7. Results .....	54
11. Data analysis of commercial systems .....	58
11.1. System Analysis .....	58
11.2. PV performance .....	59
11.3. Wind performance .....	60
11.4. Lamp Characterization .....	62
11.5. Test Conclusions .....	63
12. Mapping of hybrid system potential as function of street lighting class .....	64
12.1. Potential for the hybrid lighting system at different street lighting classes .....	64
13. Design and dimensioning of CO2 neutral luminaire .....	66
13.1. Lighting .....	66
13.2. Wind turbine .....	68

13.3.	Solar panels .....	71
13.4.	8.3 Mock up.....	71
13.5.	Lab model.....	72
14.	Conclusions.....	74
15.	Dissemination .....	76
16.	References .....	77

## 2. DANSK RESUMÉ

I det følgende gives et kortfattet resumé af projektet og dets resultater, herunder baggrunden for og formålet med projektet, hovedresultaterne samt konklusioner og perspektiverne af projektets resultater.

### 2.1. BAGGRUND

1-2 % af den samlede elektriske energiforsyning bruges i Danmark til belysning af vores veje. Størstedelen af vejbelysningen udmærker sig ved at være udgjort af master, der bryder såvel indstrømmende vind som solindfald og dermed er omgivet af energi, men på nuværende tidspunkt kun formår at forbruge energi. Masternes geometri især i højden er forskelligartede, men energiforbruget i armaturet skalerer ofte med højden – hvormed den øverste del af masten får et stort relativt frigjort areal af såvel skygge som hindringer for sol og vind, hvilket gør dem ideelle til opsamling af vindenergi og solenergi.

### 2.2. FORMÅL

Nærværende projekt har haft til dedikeret formål gennem 2 faser hver af 2 års varighed at frembringe en lysmast, der udover at fungere som en energibesparende højkvalitetsbelysningsenhed baseret på den nyeste LED teknologi og alle de fordele denne lysteknologi bringer med sig, ligeledes bliver selvforsynende med denne energi fra sine omgivelser via sol og vindteknologi. Arbejdet i fase 1 har været fordelt i følgende arbejdsopgaver

- Afdækning af kommercielle systemer
- Indkøb af de bedste kommercielle systemer
- Etablering af vejstrækning på RISØ
- Matematisk modelsystem
- Feed back fra kommercielle systemer
- Mapping af energipotentialer som funktion af vejklasse
- Udvælg vejklasse
- Designproces
- Realisering af labmodel
- Realisering af 1:1 mock-up af gennemregnet hybrid belysningssystem der sandsynligt kan fungere på den udvalgte vejklasse.

Projektet er fase 1 af et 2 faset projekt, der løber over en 4 årig periode. Nærværende rapportering er status midtvejs i projektet efter 2 års projektarbejdet baseret på ovenstående arbejdsopgaver, der har en analytisk og afsøgende karakter, mens fase 2 består af en udvikling af de svage led i kæden for realisering af et optimeret hybridsystem, realisering af en række prototyper heraf før en effektiv og succesfuld markedsintroduktion kan forekomme efterfølgende fase 2.

### 2.3. RESULTATER KONKLUSIONER OG PERSPEKTIVER

Hybridsystemer til belysning vil med sikkerhed have en plads i fremtidens bymiljø og i det moderne energisystem i fremtiden i en konfiguration, hvor energien produceres helt tæt på, hvor forbruget sker. Den meget høje pris for kabellægning, der når over 5000 kr. pr. meter i Københavns centrum og udgør 1000 DKK pr. meter i almindelighed gør det attraktivt at spare denne udgift ved realisering af stand-alone systemer. Desuden går energipriserne kun én vej –

nemlig opad og da disse hybridsystemer "sparer" energi, der alternativt skal købes inklusiv høje skatter og afgifter er besparelserne her omkring 2 kr. pr. kWh. Fremtiden ser endvidere ud til at arbejde positivt for hybride lyssystemer, da lysdioderne stadig fordobler sin effektivitet i lm/W hvert 3. år i nogen tid forude, og derfor kan energisystemet reduceres markant i fremtiden med samme lysudbytte til følge, hvilket gør det mere og mere kosteffektivt, hvilket understøtte af at de andre teknologier også er under udvikling. Også batteriteknologi har en positiv udvikling i retning af mere energitætte og holdbare systemer der tåler mange op og afladningscykler, så batteriskift kan skæres ned til fx hvert 10. år. Så der ser ud til at være en række forretningsmodeller på såvel kort, mellemlangt og langt sigt der åbner sig for det gode, veldimensionerede hybridsystem, med et godt design, der holder hvad det lover og har lave vedligeholdelsesomkostninger.

Projektgruppen har testet 4 internationale state-of-the-art hybrid gadebelysningsystemer. Det er tydeligt, at denne teknologi er meget umoden, både når det gælder teknologiens stade og såvel som markedet. Projektgruppen handlede på vegne af Københavns Kommune i undersøgelsesfasen, og der var overraskende mange mangelfulde leverancer i forbindelse med hybridsystemer. Det er ikke forventeligt at blive tolereret fra kommunal hånd. Kun ét af de fire systemer blev leveret og virkede ud af pakken, mens de andre manglede beslag, batterier, ledninger – den ene lystast manglede sågar selve masten. Samlingsvejledninger og vejledning til programmering af styreboksene var altovervejende på kinesisk, hvilket næppe er fordrende for samarbejde med danske kommuner. Producenterne synes at være overvejende producenter af små vindmøller, der skaber mersalg ved at bygge teknologien sammen med solpaneler, en lampe, et batteri og en elektrisk styring opnår at kun kalde sig lysproducent. Specifikationerne af selve lyset er dog ekstremt mangelfuldt hos alle leverandører, hvilket kan virke underligt, da indkøbere af lysmaster må være særligt interesseret i lyset og specifikationerne heraf frem for en uddybet beskrivelse af vindmøllen og dennes fortræffeligheder. Masterne havde alle farvetemperaturer på ca. 4500-7000 K og Ra værdier mellem 70 og 80. Med en ønsket farvetemperatur i omegnen af 3000 K er systemerne meget langt herfra umiddelbart.

De undersøgte systemer er ikke testet igennem et helt år, men dog i worst case perioden fra november 2012 til januar 2013. De 3 systemer, der er succesfulde systemmålinger på er ikke selvforsynende (selvom det ene er tæt på) gennem perioden, selvom de er placeret på en åben mark, der er den bedst tænkelige placering i forhold til et byrum. Styringselektronikken har tydelige svagheder med både energihøsten fra solceller og vindmøllerne. På solcellesiden burde det være kendt teknologi at opnå state-of-the-art effektivitet mens det er et kendt problem at høste energi effektivt fra små vindmøller via den elektriske styringsdel. Dette er en anden del af systemet, der er teknologisk umodent, da der ikke er nogen tekniske begrænsninger for at lave en optimeret energihøstningsenhed, og dette vil også blive adresseret i tæt samspil med Fraunhofer Institute for Solar Energy Systems ISE afdeling for powerelektronik, der er internationalt førende på området og er en velvillig samarbejdspartner i fase 2.

Vindmøllen for alle de systemer synes at performe lavere og endda meget lavere i ét tilfælde end de medfølgende effektkurver fra producenten. Lavere cut in hastighed er nødvendig for at fungere optimalt ved vindhastigheder på 1,3 m/s, som er den gennemsnitlige beregnede vindhastighed for de simulerede E2 vejklasser. Et vindmølle- og generatorsetup optimeret til netop disse vindforhold synes at være afgørende for succes af hybridsystemer i bymiljøer. Dette er et vigtigt forskningsområde, der kan gøre en stor forskel for hybridsystemer og derfor også en vigtig arbejdsopgave i fase 2.

I projektet er realiseret en matematisk model til simulering af energisystemet i hybridsystemer under forskellige urbane miljøkonfigurationer over et normal år baseret på data fra lokale vejstationer og CFD (Computational Fluid Dynamics) modeller af standardiserede byrum svarende til vejklasserne i vejreglerne. Dette værktøj har vist sig meget relevant i både evalueringen af kommercielle systemer til anvendelse på et givent sted, men også i dimensioneringsprocessen af nye hybridbelysningsystemer skræddersyet til brug i et givent miljø. Modelleringsværktøjet finder let de svage led i energikæden så de enkelte parametre såsom solpanelstørrelse,



orientering heraf, vindmølleplacering, højde, projiceret areal, rotortype, batterikapacitet optimeres til at passe til det forbrugsscenarium lyset påtrykker systemet henover året. Endvidere kan implementere forskellige lysdæmningsscenarier således at energisystemet kan optimeres med udgangspunkt i dette og ikke mindst en kostoptimering kan laves baseret herpå.

Design er som bekendt en meget subjektiv ting, men i projektet, hvor hele værdikæden er repræsenteret og især brugerne og køberne i mærkbar grad, der var der en entydig enighed om, at der kan skabes væsentlig merværdi på designsiden. Ingen af systemerne på markedet har en rigtig heldig integration af solpanelerne og for de flestes vedkommende virker det som meget sammenbragte løsninger med udgangspunkt i en pæl, som der monteres forskellige komponenter på i forskellige højde. I nærværende projekt er derfor udført et designforslag baseret på belysningskravene til en E2 vejklasse på årsbasis, der baseret på beregninger og modelværktøjet ser ud til at kunne fungere stand-alone under disse betingelser. Det bygger dog på en række antagelser, som fx at der udvikles en generator, hvor møllen starter energiproduktionen allerede ved under 1,5 m/s i vindhastighed og en optimeret elektronik er også tænkt ind. Endvidere er der taget hensyn til de dæmpningsmuligheder, der er mulige i vejreglerne for E2 veje.

Hybridbelysning har bestemt en lys fremtid men projektet har afgjort vist, at det er et energisystem, hvor det svageste led er begrænsende for performance af hele systemet. Der er alt for mange svage led i state-of-the-art systemerne, hvilket alt andet lige er til fordel for udvikling af et dansk produkt, hvor disse delsystemer er optimeret, så hele kæden spiller optimalt sammen for at realisere potentialet og opnå en løsningsmodel der kan etablere en vigtig markedsposition. Det særlig interessante ved hybridsystemer er, at de består af mange dele, som danske teknologivirksomheder kan få en interessant rolle i forhold til også på eksportmarkedet. Markedstrenden på de små vindemøller er eksplosivt stigende for nuværende, da de blive mere kosteffektive og de hurtigt opnår en teknologisk modning i forhold til deres ekstrem umodne stade. Så der er helt klar et window of opportunity nu for Danmark for at slå sig fast med systemer og komponenter til dette marked. Selve modelsoftwaren udviklet i projektet har der været stor kommerciel efterspørgsel på.

Fase 2 er en væsentlig del af løsningen for at komme derhen og gøre en hybridmasteløsning klar til at kunne begå sig på markedet. De ovenstående svage led kræver en forskningsindsats for at overkomme de tekniske barrierer, og efterfølgende skal en række prototyper realiseres og optimeres systemisk og på komponentniveau i et par iterativ loops før projektgruppen efterlader projektet hos de rette producenter til realisering af markedspotentialet for hybridlyssystemer. Fase 2 adresserer ligeledes vedligeholdelse, støj, vibration etc., hvilket er emner, der har været helt udeladt indtil videre.

### 3. INTRODUCTION

Today many efforts are seen to incorporate new renewable energy production into the energy sector. This is due to the severe environmental problems the world is facing and the knowledge that oil resources are running out.

*"Current trends in energy supply and use are patently unsustainable – economically, environmentally and socially. Without decisive action, energy-related emissions of CO<sub>2</sub> will more than double by 2050 and increased oil demand will heighten concerns over the security of supplies."* (International Energy Agency<sup>1</sup>, p. 1)

In Denmark wind turbine power production is very known and used. This is due to the high wind climates both near the coast and off the coast. Production wise Denmark is a leading country in the wind turbine market:

*"Although Denmark contains only a little over 3% of global installed wind capacity, at the end of 2008, more than one-third of all turbines operating in the world were manufactured by Danish companies."* (International Energy Agency<sup>1</sup>, p. 9)

The PV power generation is not nearly as large in Denmark as wind power production, but in the private sector the investment in PV panels is booming.<sup>4</sup>

In 2008 the Danish energy supply stated that street lighting account for 1,1 % of the total electricity consumption in Denmark (Reference is confidential). Today large initiatives are made in order to bring this share down with regulation on inefficient lighting technologies and large investments in renewal of existing light fixtures.<sup>2,3</sup>

This project has the focus of incorporating solar and wind produced energy to the energy consuming service of street lighting by integration into the mast creating a hybrid system. Since the mast and the lighting armature is needed to create the lighting onto the roads in all cases, they can in principle be considered free and the extra cost of solar panels, wind turbines and battery should be offset by the cost of cable digging and the saved energy cost in the traditional solution to be attractive. Furthermore the hybrid system needs to be highly aesthetical to be of interest to the Danish Municipalities who is very critical in when it comes to design, how it fits into the architecture, the lighting quality etc. And of course most important of all the reliability of the systems should be acceptable so the light is actually supplied when needed by the people on the streets.

The scope of the project is to develop a hybrid system working in a Danish urban environment living up the requirements of the users -> the municipalities. The project group is composed of actors in the whole value chain from researches to the user as shown on Figure 1.

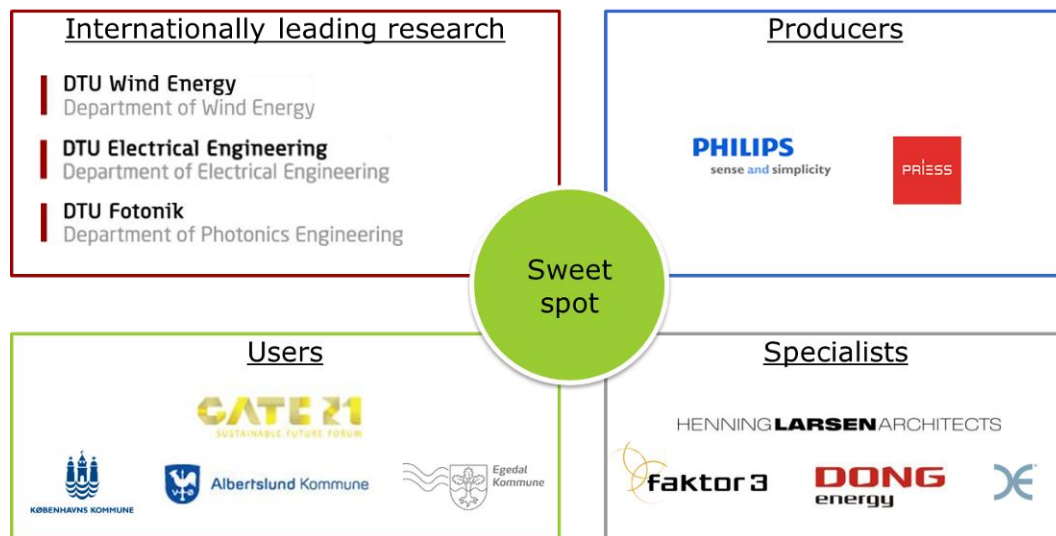

Figure 1 – The Project team

The project is therefore an example of user driven innovation having the Municipalities as active drivers in the development of the street lighting system they are intended to become costumers of when the project ends.

The project is funded by ELFORSK Project number 343-021, "Development of a carbon neutral luminaire for the urban environment" and is a phase 1 of a 2 phase project of developing the hybrid system. The development is expected to take 4 years divided into 2 phases of 2 years each.

#### 4. WHAT IS A HYBRID SYSTEM

This project works with the concept of hybrid wind solar street lights. This concept is an idea of combining electricity generation from photovoltaic panels and wind turbines with a street light. A sketch can be seen below in Figure 2. Photovoltaic will be denoted PV in the remainder of the report.

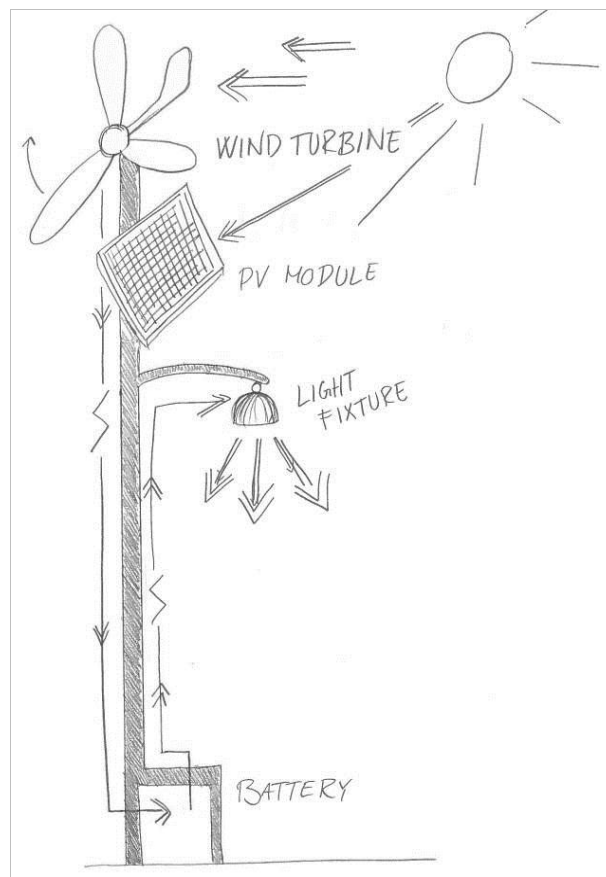

Figure 2 – Hybrid wind solar street light system

The concept is a standalone solution, which use a battery as storage capacity. The wind turbine and a PV panel will deliver power to a battery and the battery will then power the street light during the dark hours. A crucial element in this system is to always have sufficient power for the light source, since it is not acceptable to have street lights that do not light. This is especially a problem in the dark winter months, where solar power is limited and there are many dark hours where the light needs to be on.

Combining a wind turbine and a PV panel will give more variety to the power production and the system will be able to harvest energy in different weather conditions. Using PV is evident, since PV is a highly reliable source of renewable electricity. The wind turbine gives very fluctuating power production and would not be sufficiently reliable independently. The combination hopefully shows that the wind turbine can help to cover the lack of energy in the winter months. This is an important aspect of this project.

## 5. THEORY

This chapter introduces the more theoretical terms used in this report. The chapter is divided in the different sections - Light, wind, sun and storage.

### 5.1. LIGHT

Lighting is given by many different terms and definitions and in this section, parameters from photometry are described. Photometry is how light is perceived by the eye and lighting is therefore described by photometric measures. Illumination is used as a general term for light. More specific terms can be found in Figure 3 below.

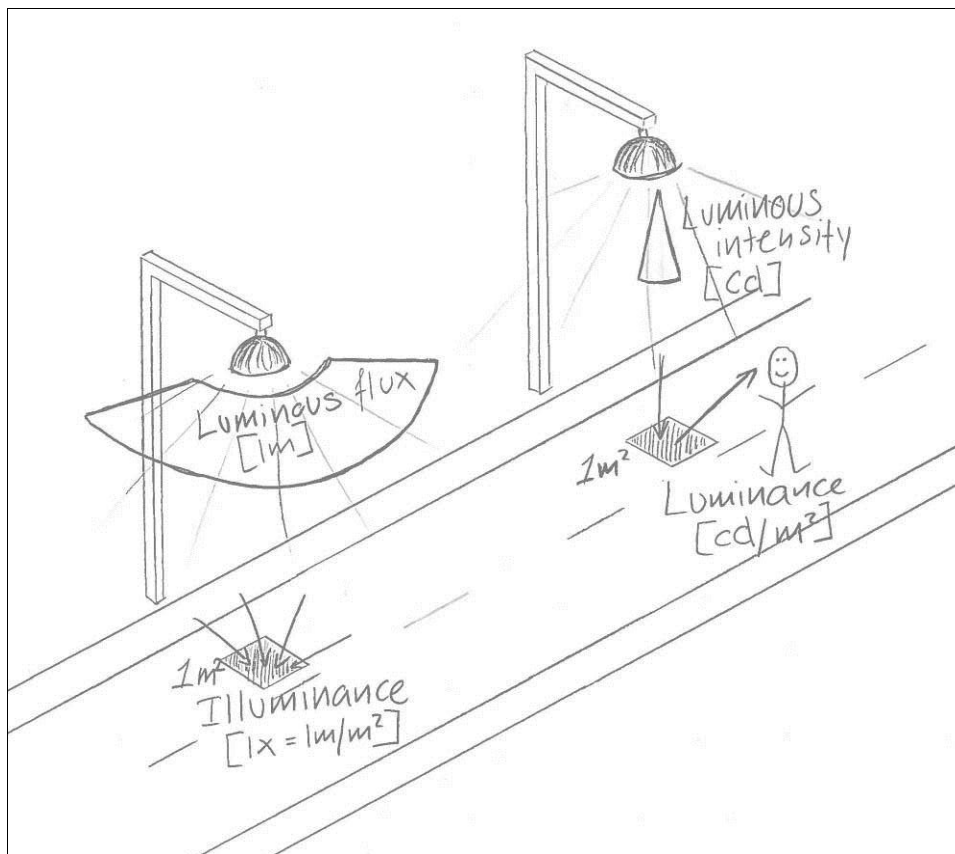

Figure 3 – Light terms with street light figure

The total luminous flux is the total amount of emitted light by a luminaire and is given in lumen [lm]. The luminous intensity is the emitted light in a certain direction within a solid angle. The luminous intensity is given in Candela [cd]. The luminous flux is equal the luminous intensity multiplied with the solid angle value for the light spread [sr].<sup>7</sup> When the luminous flux hits a surface it is termed illuminance, which is given in lumen/m<sup>2</sup> or lux [lx]. The luminance is the luminous intensity of a surface in a specific direction. It is a measure of how bright a surface appears. The luminance is given in Candela/m<sup>2</sup> [cd/m<sup>2</sup>].<sup>7</sup>

Other parameters, which are important when discussing illumination, are correlated color temperature and the color rendering index. The correlated color temperature is a measure of the color of white light. It has its origin in black body radiators equivalent temperature in order to produce light of the same white color. Correlated color temperature is measured in Kelvin [K]. In this report the correlated color temperature will be given by the name color temperature or CCT. Examples of CCT's are incandescent light bulbs with a color temperature of around 2700 K, which is considered a warm white or the sun of around 5800 K, which is considered a very cold white.<sup>7</sup> The color rendering index (CRI) is a value representing the ability to reproduce color of an object in comparison to a reference light source with the same color temperature. The CRI is given by a value up to 100, where 100 is a light source equal to or as good as the reference light source to reproduce the colors. The color rendering index is defined by the CIE (International Lighting Commission).<sup>7</sup>

The efficiency of a light source is given by the luminous efficiency, which is the luminous flux per electrical power unit [lm/W]. In some literature, this parameter is named luminous efficacy, but this is by Shubert given as the luminous flux per optical power unit.<sup>8</sup> All these values are in this report evaluated as luminous efficiency.

When evaluating lamps the utility factor and the distribution of light are also used parameters. The utility factor is the efficiency parameter of the fixture case. The parameter is a percentage value of how much of the light, from a light source, that will hit the street area. The distribution of light is how the light is spread from the light fixture. This can be given by different values, such as photometric graphs or beam angles.

## 5.2. SUN

The main parameters in regard to photovoltaic power generation are power output parameters and efficiency parameters. The most commonly used parameter is watt peak (Wp). This is the maximum power produced by a PV module (given in Watts) when exposed to standard test conditions (STC). Standard test conditions are solar irradiance of 1000 W/m<sup>2</sup>, air mass 1,5 spectra and 25°C.<sup>9</sup> This parameter is used since it is a comparable power production value.

The efficiency of a PV cell, module or panel can simply be evaluated from the amount watt peak obtainable per square meter.<sup>8</sup> For an efficiency value in percentage, the Wp/m<sup>2</sup> is divided by the solar irradiance, which is 1000 W/m<sup>2</sup> for STC. This is given by the equation:

$$\eta = \frac{P_m}{P_s \cdot A} \quad (1)^9$$

Here  $P_m$  is the maximum power,  $P_s$  is the solar irradiance and  $A$  is the area of the PV module. The equation can also be used if tested under different conditions.

The characteristic of a PV module is given by the relation between voltage and current. This can be seen in Figure 4 below. The maximum power point is given where the PV has the most optimal conditions and produces the highest available power. In Figure 4 this is at the peak of the blue line.  $I_m$  and  $V_m$  are the current and voltage for the maximum power point.

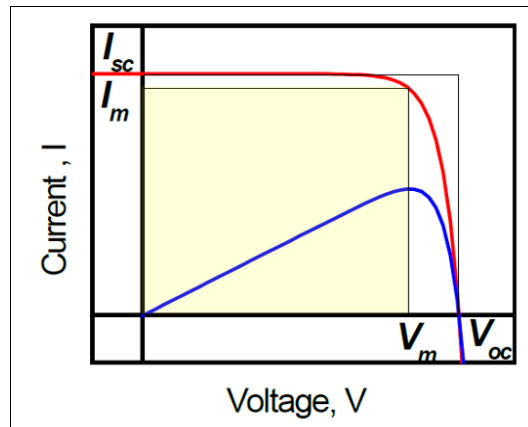

Figure 4 – I,V characteristic (red) and power curve (blue), maximum current and voltage, short circuit current and open circuit voltage are given (Kardynal<sup>10</sup>, p. 18)

Further than the efficiency, the fill factor<sup>11</sup> for the PV module can be found. The fill factor describes the PV module in more detail and gives a more detailed numerical indicator of how good a module is. Amongst other things, a high fill factor means that the module will perform well in also cloudy weather, whereas the efficiency only states how the module performs with sun (1000W/m<sup>2</sup>). The fill factor is given by:

$$FF = \frac{I_m \cdot V_m}{I_{sc} \cdot V_{oc}} \quad (2)^9$$

Here  $I_{sc}$  is the short circuit current,  $V_{oc}$  is the open circuit voltage and both can be seen in the I,V-characteristic in Figure 4. The more square the red I,V-curve is, the higher the fill factor. The fill factor value is important to compare in Denmark, since half of the electricity generated by a PV module originates from diffuse radiation.<sup>12</sup>

The efficiency of a module can also be found from the fill factor:

$$\eta = \frac{I_{sc} \cdot V_{oc} \cdot FF}{P_s \cdot A} \quad (3)^9$$

Tilt and azimuth angle are often used in regard to solar power production. The tilt angle describes the angle between the PV module and horizontal. The azimuth angle is the orientation of the PV module, where south is given by 0°.

### 5.3. WIND

Concerning wind energy and turbines, different parameters are used in describing a wind turbine and its performance.

Five different wind speed measures are used:

- The rated wind speed is a given wind speed for which, the rated power output can be extracted.
- The start up and survival wind speeds define the range for which the rotor will rotate.
- The cut in and cut out wind speeds define the range for which the generator is active and produce power.

The rotor parameters, as seen in Figure 5 are:

- The swept area, which is the area in which the blades rotate, perpendicular to the wind direction.
- The tip speed ratio (tsr) is the ratio between the wind speed and the speed at the tip of the blades ( $V_T$ ) or the outermost point of the blades.

In Figure 5 the swept area and tip speed are given for a horizontal rotor and an H-rotor.

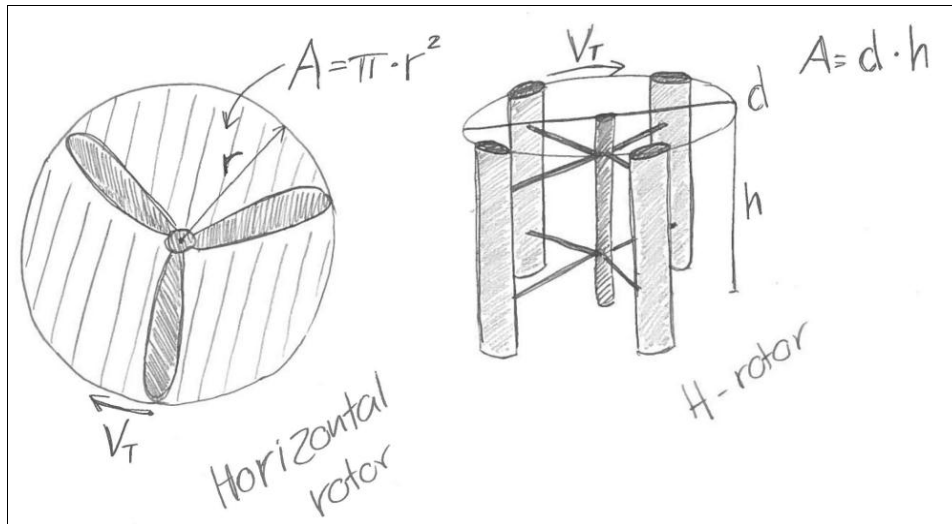

Figure 5 – Swept area and tip speed a horizontal rotor and an H-rotor

The power output of a wind turbine is highly dependent on the wind speed. This is described by the power equation:

$$P = \frac{1}{2} \cdot \rho \cdot u^3 \cdot A_{rotor} \cdot C_p(u) \quad (4)^{13}$$

Here  $P$  is the power output,  $\rho$  is the air density,  $u$  is the wind speed,  $A_{rotor}$  is the swept area of the rotor and  $C_p$  is the power coefficient. From the equation it is also seen that the power output is proportional to the swept area and the power coefficient.

The power coefficient defines the amount of wind power that the turbines are able to capture and convert into electricity. The power coefficient has a theoretical limit, the Betz limit of 59%.<sup>13</sup> The  $C_p$  value is a good evaluation parameter, since it describes the efficiency of the turbine compared to others and can also indicate the reality of information given by suppliers, since these tend to be very positive.<sup>c</sup> The  $C_p$  value can be calculated from the power equation and for instance rated wind speed and rated power output:

$$C_p(u) = \frac{P \cdot 2}{\rho \cdot u^3 \cdot A_{rotor}} \quad (5)$$

#### 5.4. STORAGE

For a standalone hybrid lighting system, storage of the electricity is needed, which will be solved by a battery. For storage ampere hours or watt hours are used as capacity units.



Ampere hours [Ah] is the capacity unit mostly given by suppliers and is 1 Ampere delivered for 1 hour. When multiplied by the voltage level watt hours [Wh] or kilowatt hours [kWh] are found.

Another term used in relation to battery capacity is number of storage days, which in this project is the number of days the system can produce light, without having any power production from the PV module or the wind turbine.

## 6. TECHNOLOGIES

In this chapter the different technologies are presented and discussed. These contribute to the frames for the solution and identify the possibilities for a hybrid lighting concept.

The technologies of a hybrid system are described and different sub technologies within these fields are explained. The different technologies are analyzed by state of the art research and advantages and disadvantages for different technologies.

### 6.1. LIGHT

Artificial lighting can come from different sources. The best known and oldest technology is the incandescent light bulb. Due to low efficiencies however, the incandescent light bulb is phased out due to recent legislation by the European Union, amongst others, and will leave the market completely within 2012.<sup>14</sup>

For outdoor lighting for streets and parks, incandescent light has been out for some time. Today less than 0.1 % of the light fixtures in Copenhagen<sup>a</sup> are incandescent.<sup>3</sup> This is due to other light technologies with much higher efficiencies, as can be seen in Figure 6. Also for the high pressure discharge lamps the most inefficient are being taken off the market by regulation.<sup>2</sup> From 2012 and 2017 there are set demands for luminous efficiency for fluorescent, high pressure sodium, metal halide and mercury lamps.<sup>15</sup>

---

<sup>a</sup> The municipality of Copenhagen is denoted Copenhagen

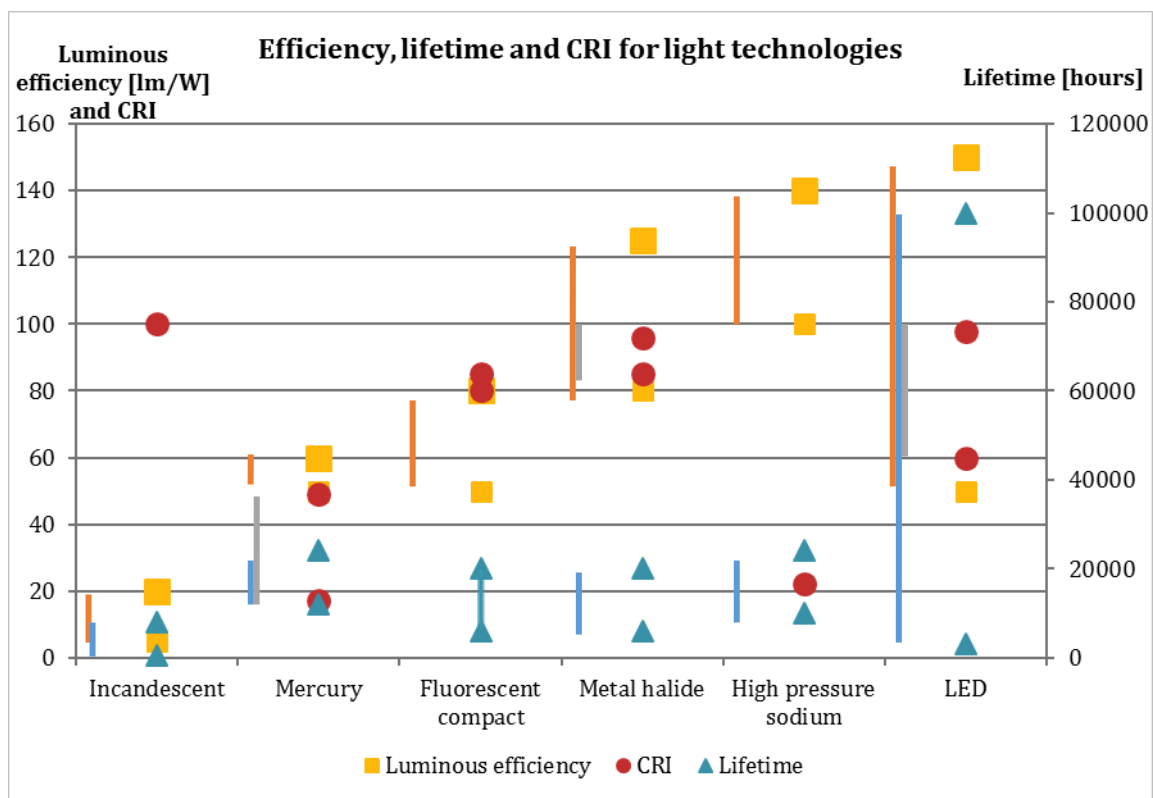

Figure 6 – Luminous efficiency, lifetime and CRI for different lighting technologies <sup>D, 8, 16, 17</sup>

In Copenhagen today the most used light technologies are high pressure sodium, fluorescent compact and tubes, mercury and metal halide lamps.<sup>3</sup> There will be more on this later in the street light chapter. Of these technologies high pressure sodium has the highest luminous efficiency with up to approximately 140 lm/W, as seen in Figure 6. The three other follows, metal halide with up to approx 125 lm/W, fluorescent with approx 80 lm/W and mercury with approx 60 lm/W. LED<sup>b</sup> is a rather new technology for outdoor lighting and only account for less than 1 % of the light in Copenhagen. But as seen in Figure 6, has very good prospects with the highest luminous efficiency of up to 150 lm/W, high CRI and possibilities for very long lifetime. The municipality is no longer installing mercury and high pressure sodium, due to the environmental impact and poor color rendering, which is also seen in Figure 6. Both technologies are being replaced by metal halide.<sup>18</sup> When installing new light fixtures today in the municipality of Copenhagen, the choice lies between compact fluorescent, metal halide and LED.<sup>E</sup> The prospects of these three technologies will be described briefly below.

### 6.1.1. METAL HALIDE AND COMPACT FLUORESCENT

Metal halide lamps are discharge lamps and similar to mercury and sodium lamps, but have better features. The metal halide light has a high color rendering reaching 95 and a color temperature of 3.000 K.<sup>18</sup> The luminous efficiency is up to approx 125 lm/W according to Figure 6, and according to Philips this can be up to approx 130 lm/W.<sup>F</sup> Metal halide has a lifetime of up to 20.000 hours, which is seen in Figure 6. As a fixture, metal halide has the same form as incandescent, but is much more efficient.<sup>18</sup> Compared to LED, metal halide is much less expensive, between 50 to 75 % the price of a LED fixture.<sup>F,E</sup>

<sup>b</sup> Light emitting diode

Compact fluorescent light also has high efficiencies of up to approx 80 lm/W<sup>14</sup> and a lifespan similar to metal halide. Compact fluorescent is also inexpensive compared to LED. An advantage for the compact fluorescent light is that it is a standard fixture and therefore fits in existing sockets and fixtures and is therefore easy to replace.

A disadvantage for both metal halide and compact fluorescent, in regard to street lighting, is that the light is sent in all directions and specific reflectors are needed to direct the light downwards to the road. These light sources are therefore very dependent on the fixture cases and how effectively they can direct the light. The utility factor, which describes the fixture efficiency, is compared. Three different fixtures with conventional light technology have utility factors between 60 and 65 %. Compared to LED, which is introduced below, the same fixture with LED can achieve a utility factor of 79,6 %.<sup>19</sup>

### 6.1.2. LED

LED is not a new technology, but is fairly new within the field of white light illumination. Earlier the technology is seen in calculators, cell phones and TVs. In 1995 white LEDs emerged from ultra violet LEDs with phosphor coating, converting the ultra violet radiation into white.<sup>16</sup> Today the conventional white LED is a blue LED with phosphor coating. Color mixing is also used to create the white light, by mixing red, green and blue LEDs.<sup>16</sup> White LEDs on the market today reach a luminous efficiency of 150 lm/W, and 230 lm/W in the laboratory.<sup>D</sup> These high efficiencies are for LEDs with cold white light. For warmer white light the efficiencies decrease. Philips states a luminous efficiency of 140 lm/W at 4.000 K and 20 % less for LEDs at 3-000 K. Besides the high efficiencies of LEDs, there are numerous other advantages for this lighting technology:

- Very long lifespan of up to 100.000 hours<sup>16</sup>, while a more realistic the range is from 50.000 to 80.000, which is still very high<sup>11,E</sup>
- Can achieve very high CRI values
- All color temperatures can be achieved by both white LEDs or color mixing
- Light can be specifically directed, which in some cases also can be a negative feature
- No ultra violet or infrared radiation<sup>16</sup>
- Use DC current, which is an advantage in this project, since PV and wind turbines produce DC current. No conversion is needed.
- Possible to dim to e.g. 50 %

Disadvantages are primarily that LEDs are very expensive compared to metal halide and compact fluorescent and that LEDs work best with lower temperatures, cannot function at warm temperatures and therefore needs to be cooled. This is mostly handled with a passive cooling system, which lead the heat away from the LED.

A commercial problem for LEDs is the lack of existing standards for the formation of LEDs; the diodes can be arranged in many different manners to create the wanted light fixture. The diodes are small and more are needed to be put together to achieve the luminous flux needed for a specific lamp. Today these arrangements have very different appearances as is seen in Figure 7. This means that it is not easily fit into existing fixtures and cannot be guaranteed for the future. An attempt to create standards on the area, are emerging by the cooperation Zhaga, where manufacturers collaborate to create interchangeable fixtures.<sup>20</sup> Zhaga's suggestion for street lighting is just launched in March of 2012 and seen in Figure 7. It is seen that the Zhaga standard is somewhat similar to Ledgine board from Philips.

			
"Ledgine" - Philips (Philips <sup>21</sup> , p. 6)	"Imiteret lys" – Philips (Philips <sup>21</sup> , p. 6)	Focus Lighting – Philips (Olivarius <sup>22</sup> , s. 6)	Streetlight engine - Zhaga (Zhaga <sup>20</sup> )

Figure 7 – LED setups

### 6.1.3. FURTHER COMPARISON

A brief comparison of the spectral distribution for the different technologies is seen in Figure 8. The figure shows the very narrow peaks for the metal halide and the compact fluorescent, whereas the LEDs have a more continuous spectra. As previously stated the LED color mixing can create all color temperatures and in Figure 8 only one is presented. The warm white LED is seen here to be close to the spectral distribution of the incandescent light, with the high intensities in the red region.

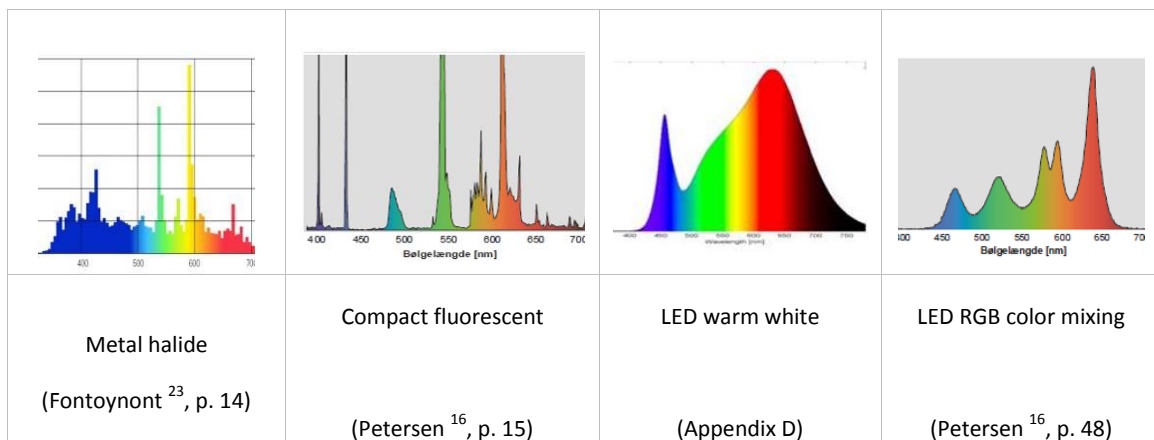

Figure 8 – Spectral distribution for the different lighting technologies

When looking into the future it is predicted that luminous efficiencies for LEDs will increase, warm white LEDs from 140 lm/W today to 250 lm/W in 2020.<sup>24</sup> Furthermore it is expected that the price for LEDs will drop significantly to a quarter of the price today in 2020<sup>24</sup>.

Metal halide and probably also compact fluorescent will also evolve in the future, but it is not known to which extent.<sup>F</sup> The progress will be much more moderate, than what is seen for LED, since both these technologies are older and more mature.

## 6.2. PV

Photovoltaic technology is today mostly crystalline Silicon, which has been on the market for the past 60 years and accounts for 90 % of installed PV systems today.<sup>B,12</sup> Other PV types are entering the market, these are thin film and organic PVs, which are similar technologies.

Using PV technology for power production is, for renewable energy sources, a very stable production method, as PV systems also have the ability to absorb diffuse lighting. This ensures that some energy can be harvested every day of the year. In Denmark, due to the very northern locations, the days are very short in the winter months and this can be seen in the seasonal variation in output from PV as illustrated in Figure 9.

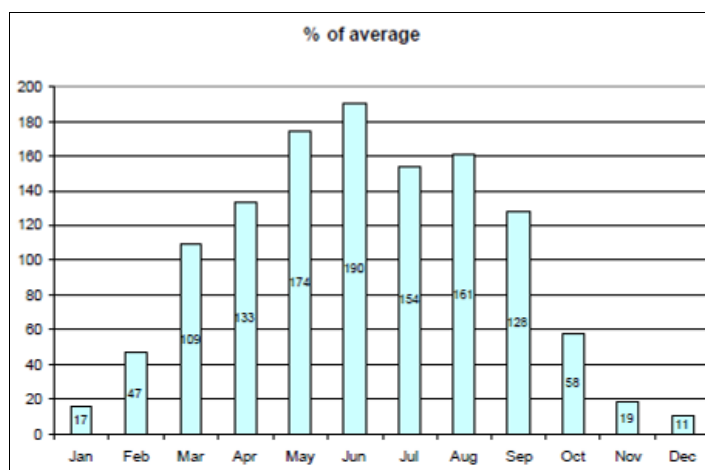

Figure 9 – Seasonal variation for PV power production in Denmark.<sup>12</sup> The tilt and azimuth angle is not given.

### 6.2.1. PV TECHNOLOGIES

Crystalline Silicon is the dominant PV technology and will continue to be so until at least 2020.<sup>12</sup> Silicon technology is divided in two categories – mono- and polycrystalline, which as the name states are related to the arrangement/structure of the silicon crystals. Mono crystalline is the more efficient of the two and may give up to 200 Wp/m<sup>2</sup> (efficiency: 20 %).<sup>B</sup> More standard mono crystalline devices have efficiencies around 150-170 Wp/m<sup>2</sup> or in efficiency terms 15–17 %.<sup>B</sup> Polycrystalline Silicon modules have slightly lower efficiencies around 13-15 %.<sup>25</sup>

Thin film PV systems are based on different elements and are characterized by very thin semi-conductors, which is held together by e.g. glass.<sup>12</sup> The semi-conductor material is produced by a chemical reaction and therefore has a less energy demanding and cheaper production than crystalline Silicon.<sup>9</sup> The thin film systems have efficiencies up to 10 %.<sup>B</sup>

Organic PV devices, such as organic, polymer and dye-sensitized PVs are newer technologies. These are produced by e.g. combination of dyes and can therefore be produced with even less energy and cheaper than thin film, but still struggle with very low efficiencies and are not expected to commercialize on a larger scale before 2020-2030.<sup>B,12</sup>

## 6.3. WIND

Generation of power from wind is an ancient technology. Generating electricity is more than 30 years old<sup>1</sup> and is therefore cited: “Wind energy is perhaps the most advanced of the new technologies, but there is still much work to be done” (IEA<sup>1</sup>, p. 1). But even though wind power generation is an established technology, the same cannot be said for wind power production in urban areas.<sup>26</sup>

Using wind turbines for power production, results in very fluctuating power levels compared to solar power production and especially thermal power production. But a combination with photovoltaic panels in production gives possibilities of producing power in very varied weather. The seasonal variation in wind energy potential is seen in Figure 10. There are high potential for energy production in the winter months, which therefore is a very good combination with the solar energy seasonal variation seen earlier in Figure 9.

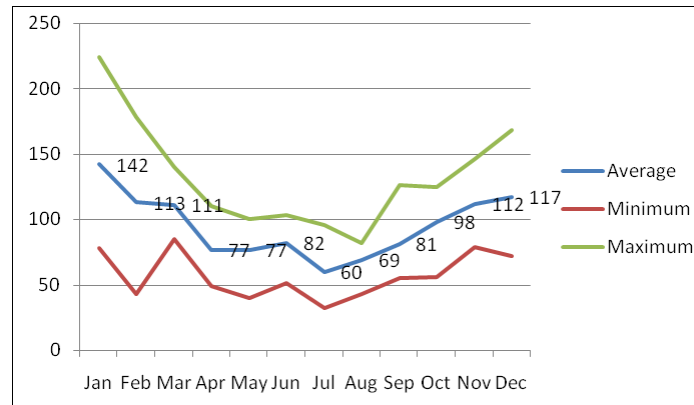

Figure 10 – Wind energy for Denmark, given in percentage of yearly average. Blue curve represent the monthly average over a 10-year period, green and red curve represent the maximum and minimum monthly average.<sup>12</sup>

In urban environments the wind speed averages are given to be between 2 and 4 m/s, as seen in Figure 11.

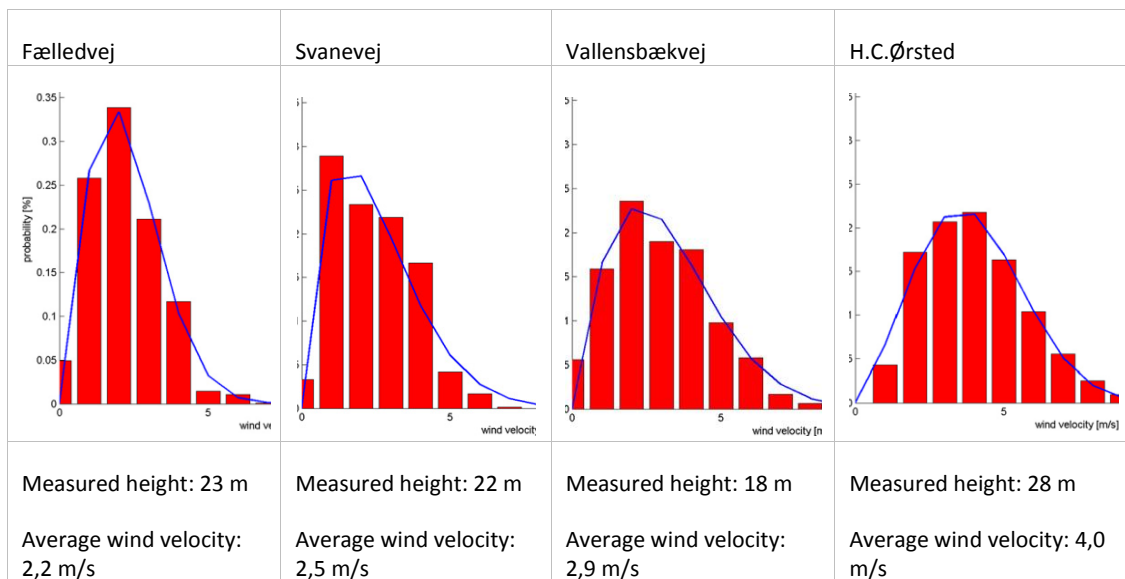

Figure 11 – Urban wind climates in Copenhagen<sup>13</sup>

In Figure 11 is seen the wind climates for different urban sites in Copenhagen and it is seen from the different figures, that wind speeds are generally below 5 m/s. At what height the measurements are done, have large influence on the wind speeds. Vallensbækvej is not located in the municipality of Copenhagen, but still represents the urban environment.

### 6.3.1. WIND TURBINE TECHNOLOGIES

Horizontal wind turbines with three blades are very conventional and can be found many places around Denmark and all over the world. Differences in size and base constructions can be seen between on shore and off shore turbines. Off shore is a newer technology and allows for higher wind speeds in more undisturbed wind climates.<sup>1</sup> Newer designs of wind turbine present different vertical rotor types.

The horizontal rotor types are as stated before mostly presented by the classic three blade rotor design, which is seen in Figure 12. Horizontal rotors can also have more or less blades and can be placed differently according to the rotational axis, see Figure 12.

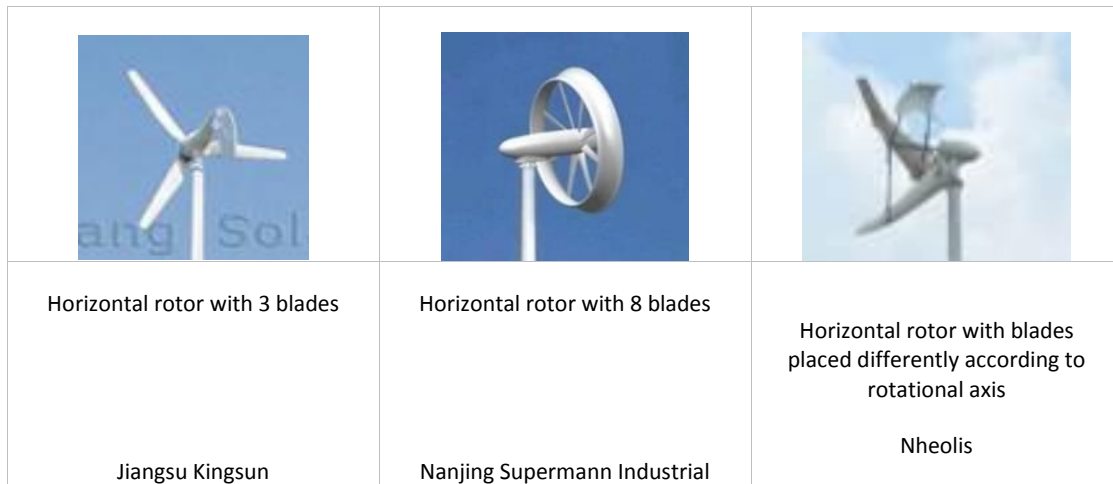

Figure 12 – Horizontal rotor types<sup>6</sup>

The vertical rotor types differ more in design with the three main categories – H-rotor, Darrieus rotor and Savonius rotor, which can be seen in Figure 13. Both the Savonius and H-rotor are also seen with twisted blades, see Figure 14.

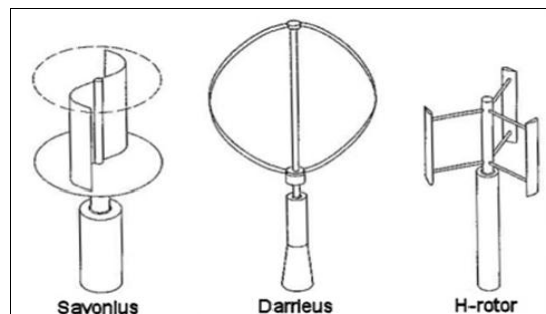
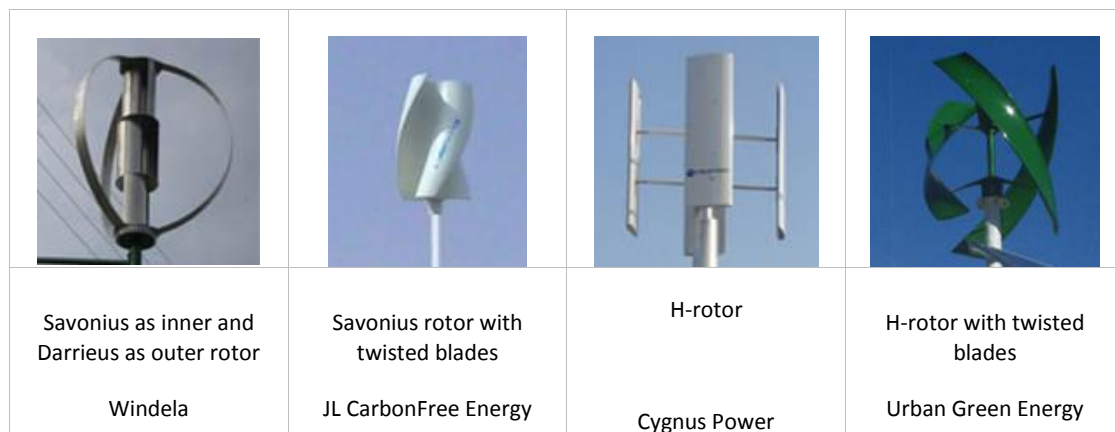

Figure 13 – Vertical rotor types (Beller<sup>13</sup>, p. 64)

The main difference in the vertical rotor types is that Savonius is driven by drag, while Darrieus, H-rotor and also classic horizontal are driven by lift.<sup>c</sup> A further difference is that the Savonius rotor is solid, where the H-rotor and the Darrieus rotor are open in their design.

<sup>c</sup> "A fluid flowing past the surface of a body exerts surface force on it. Lift is the component of this force that is perpendicular to the oncoming flow direction. It contrasts with the drag force, which is the component of the surface force parallel to the flow direction." (Wikipedia<sup>28</sup>, Lift (force))

Figure 14 - Vertical rotor types<sup>6</sup>

### 6.3.1.1. HORIZONTAL VS. VERTICAL TURBINES

There are advantages and disadvantages when comparing horizontal axis wind turbines with vertical axis wind turbines.

Horizontal wind turbine design is the classic design and has been used for many years, which gives experience. Of manufacturers today, there are more than 3.5 times as many manufacturers of horizontal turbines compared to vertical on the market for small wind turbines.<sup>27</sup>

One of the major differences between the rotor types is how they can receive the wind. The vertical axis turbines can receive the wind from any direction and thereby also handle higher turbulence, which is very important in urban environments.<sup>c</sup> The horizontal rotor can receive wind from one direction. With a yaw system<sup>d</sup>, the direction can change, but it is a slow process and is therefore not able to handle turbulence very well. Generally it is hard to know how the wind turbine performs under turbulent wind conditions.<sup>c</sup>

Horizontal turbines are considered to have higher efficiencies than vertical turbines. But when considering small scale turbines in urban environments, as in this project, this difference diminishes because of the variation of wind directions.<sup>13</sup>

According to Beller<sup>13</sup>, p. 66, other advantages of the vertical axis are:

- *“independent of wind direction*
- *generator can be located on the ground (structural advantage and maintenance accessibility)*
- *less noise*
- *withstands high turbulences*
- *symmetric and aesthetic”*

Disadvantages are that the lift driven vertical rotors are not always self starting, that fixation is needed in two points and that they have a lower Cp values than horizontal.<sup>13</sup>

### 6.3.1.2. VERTICAL TURBINE DIFFERENCES

<sup>d</sup> Most small scale horizontal turbines have passive yaw systems, like a wind vane<sup>13</sup>



Between the different vertical rotor designs there are also advantages and disadvantages. These are given within three sub categories – design, function and efficiency.

## DESIGN

As stated earlier a clear difference is in the open and solid visual design. The solid design has higher aesthetics, first because the motion of the rotor is not as apparent as with an open rotor. Also flickering of sunlight can be a problem for open visual designs in urban environments and give high disturbance for residents. There is also a health issue here in regard to epileptic seizures.

The Darrieus and the H-rotor are somewhat similar, but have some differences. The advantage for the Darrieus is that the functional design gives less stresses and the blades can therefore be lighter for the same strength. An advantage for the H-rotor is that for the same height and diameter, the swept area of the H-rotor is larger than that of the Darrieus.<sup>13</sup>

## FUNCTION

The tip speed ratio differs between the different turbine designs. Since the Savonius rotor is drag driven, it will only have a tip speed ratio of 1, while the Darrieus, H-rotor and horizontal will have a higher ratio. This is an advantage of the Savonius rotor when considering safety because of the risk that parts will become loose and fall off during operation; with lower tip speed ratio, the rotor parts will have lower speeds. In terms of aesthetics, the lower speeds give a less disturbing appearance.<sup>c</sup>

A disadvantage for both the Darrieus and the H-rotor is that they are not self starting. This can be solved with passive pitch systems, which can be a wind vane that pitches the blades or other drag driven devices to help start up the turbine. A small Savonius turbine can be combined to start up a larger Darrieus or H-rotor. This example can be seen later in the commercial hybrid systems.<sup>c</sup>

## EFFICIENCY

The efficiencies of the turbines are given by the power coefficient  $C_p$ . Typical  $C_p$  values for the Savonius and Darrieus turbine can be seen below in Figure 15. Here Darrieus is given to be able to extract twice the amount of power as the Savonius rotor, but at much higher tip speed ratios. The H-rotor generally has higher power coefficient values than the Darrieus.<sup>13</sup>

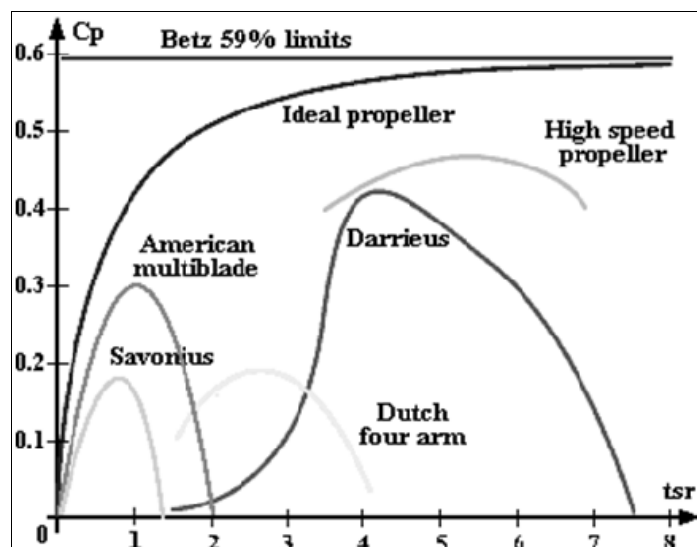

Figure 15 – Power coefficient values vs. tip speed ratio (Beller<sup>13</sup>, p. 66)

For small wind turbine rotors the high  $C_p$  values are not realistic. Realistic maximums could be 30-35 % at the highest for lift driven turbines and 25 % for drag, which is the Savonius.<sup>C</sup> The  $C_p$  value can both be given in percentage or by a 0 – 1 number, both of which are used in Figure 15.

#### 6.4. BATTERY

The development of electric vehicles has increased the focus on batteries and therefore research and development in battery technology has increased in the recent years.<sup>12</sup>

Lead-acid batteries are the oldest of the battery technologies seen today, while lithium-ion batteries have the largest range in application.<sup>12</sup> Nickel Cadmium (Ni/Cd) has also been widely used, but lithium is taking over.<sup>H</sup>

The different battery technologies can be compared on energy density, number of cycles and energy efficiency. This comparison is seen below in Table 1. It is seen that Lithium has a much higher energy density and higher efficiency, while Nickel Cadmium has more cycles. It should be said that this information is from 2006 and therefore somewhat out of date. Senior researcher Poul Norby states efficiency for Lithium of 95 %, with only 5 % loss through heat dissipation.<sup>H</sup>

	Lead-acid	Nickel Cadmium	Lithium-ion
<b>Energy density [Wh/kg]</b>	40	60	125
<b>Number of cycles</b>	500	1.350	1.000
<b>Energy efficiency [%]</b>	82,5	72,5	90

Table 1 – Battery technology comparison on energy density, number of cycles and efficiency.<sup>29</sup>

Different mixtures with lithium are used today, examples are Cobalt, Manganese, Titanium and Iron.<sup>H</sup> There are different characteristics for the different mixtures. Cobalt is the most used, but has problems with few charge cycles. Manganese is especially used in electric vehicles. Both Iron and Titanium are relatively new technologies and both offer many more charge cycles than Cobalt, but have less energy intensity. The price of Lithiumtitanate (Lithium and

Titanium) is still high.<sup>H</sup> All the lithium batteries must have some sort of control system, since they must not discharge or charge completely to avoid damage to the batteries.

## 7. STREET LIGHTING

The municipalities have the responsibility for lighting the roads of Denmark. Larger national roads and motorways are under The Danish Road Directorate. Street lighting in Denmark must conform to the Danish road regulatory<sup>30</sup> and a list of demands set by the municipality.

This chapter contains information about the street lighting in Copenhagen today and their future expectations and demands for street lighting. Following this the road regulation for street lighting is presented.

### 7.1. STREET LIGHTING IN COPENHAGEN

Today there exist about 45.000 light points in Copenhagen. 42.000 of these are for street lighting.<sup>E</sup> As stated earlier these are placed at all road types except motorways. The light fixtures used today on the streets of Copenhagen are given in Figure 16 below.





				
Copenhagen fixture on mast and in wire Philips	Icon Mini Opal on mast and in wire Louis Poulsen Lighting	Icon Mini Opal on mast and in wire Louis Poulsen Lighting	Park View Philips	Park View Philips
Preferred fixture on regional roads and distribution streets	Preferred fixture on neighborhood streets, local roads and shopping streets	Preferred fixture on neighborhood streets, local roads and shopping streets	Preferred fixture on paths, passages and some smaller local roads.	Preferred fixture on paths, passages and some smaller local roads.

Figure 16 – Light fixtures used in Copenhagen<sup>32</sup>

The aesthetic expression for the Copenhagen fixture and the Icon Mini Opal seen in Figure 16, is very similar with the half sphere. Newer interpretations of the Copenhagen fixture are seen by Philips today, where also LED light technology can be incorporated. Examples of this can be seen in Figure 17.

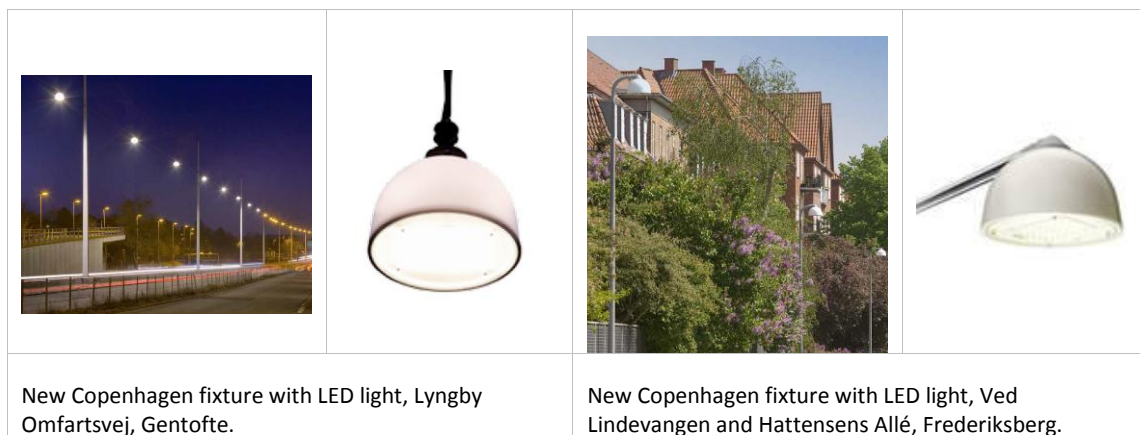

Figure 17 – New Copenhagen fixtures with LED light <sup>33, 11</sup>

The new Copenhagen LED fixtures replace high pressure sodium in Gentofte and in Frederiksberg they replace mercury lamps.

Today Copenhagen use the lighting technologies found in Table 2, which is seen below.

	Number of lamps	% of lamps
High pressure sodium	12.960	30,5
Fluorescent	10.945	25,8
Mercury	9.138	21,5
Metal halide	7.790	18,3
Induction	628	1,5
Halogen	381	0,9
LED	300	0,7
Incandescent	33	0,1

Table 2 – Light technologies used in Copenhagen <sup>3</sup>

High pressure sodium, fluorescent, mercury and metal halide are very dominant with more than 96 % of the lamps in Copenhagen. As mentioned earlier in the lighting technology section, it is only metal halide, compact fluorescent and LED, that are implemented today.<sup>E</sup> In the recent years many mercury lamps have been changed to metal halide and LED and this has impacted the electricity consumption for street lighting, which is seen in Figure 18.

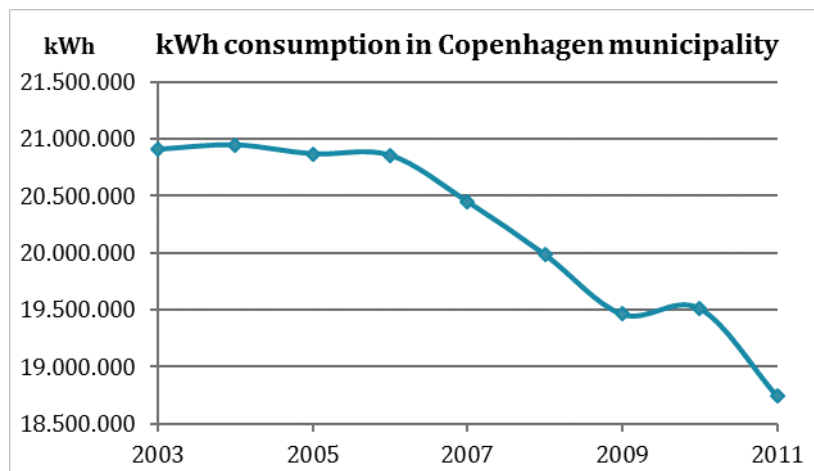

Figure 18 – Electricity consumption for street lighting in Copenhagen <sup>E</sup>

Within the next 12 years it is planned that 34.300 light fixtures should be changed in Copenhagen. This is 76,2 % of all fixtures in the municipality. The remaining light fixtures are planned to be changed in the years 2025 to 2034. The details in this plan is that within the next two years, at the latest in 2014, all mercury and induction lamps are to be changed together with 2.000 of the high pressure sodium lamps. Before 2024 the remaining high pressure sodium are to be changed together with 8.000 fluorescent fixtures on old masts. Where also the masts are to be changed. <sup>3</sup>

### 7.1.1. DEMANDS AND PRIORITIES FOR STREET LIGHTING

In the process of changing the light fixtures in Copenhagen the municipality has a list of wishes and demands along with priorities. The priorities are given by:

*“Financed replacement has high priority, which is energy savings hand in hand with CO<sub>2</sub> abatement are top priority political. The design expression is also important, because we have to be true to lighting strategy, architecture politics and soon to come design policy. The green message is important and it is the energy savings, which has to finance the replacement. Finally the fixtures are more than 40 years old and have to be replaced no matter what.”* <sup>E</sup>

Above is stated, that the number one priority is energy savings, by Thomas Maare, who is responsible for the light in the municipality of Copenhagen.

According to the lighting strategy for Copenhagen, more specific demands for lighting are given. The color temperature of the light has to be 3.000 K, unless other is specifically agreed-upon. Furthermore the light has to have a good color rendering index of at least 70 and preferably above 80. <sup>32</sup> The Danish road regulation states that the color rendering index should just be above 50 <sup>30</sup>, which is not nearly as high as the demand from the municipality of Copenhagen. In regard to hybrid street light systems there are no defined demands, since it has not yet been seen in Denmark. The system has to obey the wish for aesthetics and design expression and for all new light fixtures, a test has to be set up for visual approval. <sup>32</sup>

## 7.2. DANISH REGULATION FOR STREET AND ROAD LIGHTING

The Danish regulatory for street and road lighting defines a number of illumination classes. These classes are then applied for certain road types and intersections. The L classes are for motorways and trafficked roads, E for local roads, paths and parking lots, LE for intersections etc. and F for pedestrian crossings. <sup>30</sup>

For street lighting the municipality of Copenhagen uses the illumination classes given in Table 3 together with the road types. The highest level illumination class is given first. Figure 20 shows the distribution of street types within Copenhagen and these are combined with the illumination classes in Table 3.

Illumination class	Road description	Color correspondence with Figure 19
L4 (previous L2)	Large heavily trafficked roads, such as Lyngbyvej and Tomsgårdsvej	Red
L7A or B	Trafficked streets	Dark and light blue
E1	Local streets in the inner city	Dark grey
E2	Local streets in the suburb areas	Dark grey

Table 3 – Illumination classes, road description and color correspondence to map below <sup>E</sup>

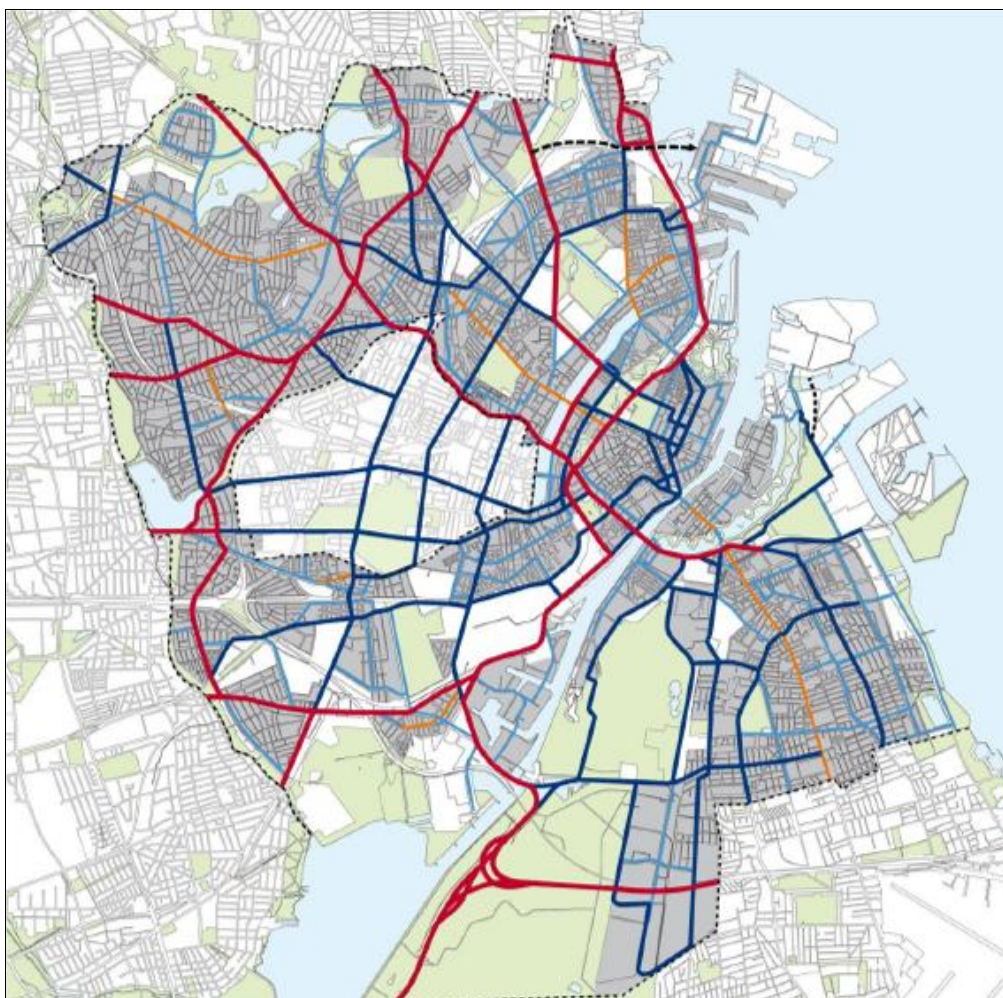

Figure 19 – Street hierarchy for Copenhagen. Red are regional roads, dark blue are distributional streets, light blue are neighborhood streets, orange are shopping streets and dark grey are local streets. (Maare<sup>3</sup>, p. 9)

Local streets, which are the dark grey in Figure 19, account for more than 70 % of the streets in Copenhagen.

The regulatory demands for the illumination classes used in Copenhagen can be found below in Table 4 and Table 5.

	L4	L7A / B
<b>Luminance on dry road:</b>		
Average luminance (Lm) cd/m2 (operation value) minimum	1,5	0,75 / 0,50
Uniformity (R) minimum	0,40	0,40
Longitudinal uniformity (RL) minimum	0,30	0,30
<b>Luminance on wet road:</b>		
Uniformity (R) minimum	0,15	0,15
Glare w. visual dispair (TI) % maximum	6,5	7,0
Illumination class on the nearest 3,5 m	E1	E2

Table 4 - Light classes L4 and L7A and B <sup>30</sup>

	E1	E2
<b>Hemispherical illuminance (on the traffic area as a whole):</b>		
Average illuminance (E <sub>h</sub> ) lx (operation value) minimum	5,0	2,5
Uniformity (R) minimum	0,15	0,15
Glare number for fixtures:	D5 and D6	

Table 5 – Light classes E1 and E2 <sup>30</sup>

Calculation methods for the parameters luminance, illuminance and uniformity are described in the following sections along with a calculation example.

An additional regulatory input is the recommended maximum height for light fixtures. This is 10 m for motorways and large trafficked streets, 8 m for smaller trafficked streets and 5 to 6 m for local streets.<sup>30</sup>

### 7.2.1. LUMINANCE AND ILLUMINANCE

Both the average luminance and illuminance can be calculated from the illumination level. The illumination level is defined by the luminous flux of the light source on to the street area given by the street width and the distance between the light sources (equation 6). The average illuminance on a horizontal surface is given by the illumination level and the utility factor (equation 7). The utility factor is how much light from the light source that reaches an intended part of the street.<sup>34</sup> The utility factor is dependent on different settings. The optics play a vital part here, in directing the light to where it is needed and ensuring that as much light as possible is led out of the fixture and in the right direction. Also the placement of the lamp post in regard to the street plays a vital role. By the Danish Road Directorate, this utility factor is given to be 30 %.<sup>34</sup>

$$B = \frac{F}{A} \tag{6}$$

$$E_a = B \cdot Uf \tag{7}$$

$$L_a = E_a \cdot Qd \tag{8}$$

$$E_h = E_a \cdot 0.65 \tag{9}$$

Luminance calculation:  
The average luminance is calculated by multiplying the average illuminance on a horizontal surface by

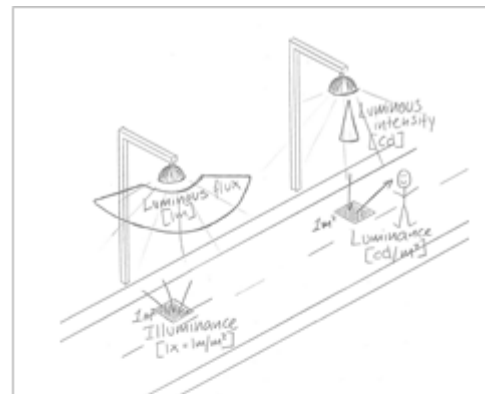

Figure from theory chapter - Light terms

- B = Illumination level [lm/m<sup>2</sup> = lx]
- F = Luminous flux [lm]
- A = Street area [m<sup>2</sup>]
- E<sub>a</sub> = Avg. illuminance [lx]
- Uf = Utilityfactor [%]
- L<sub>a</sub> = Avg. luminance [cd/m<sup>2</sup>]
- Qd = Luminance coefficient for diffuse illumination [cd/m<sup>2</sup>\*lx]
- E<sub>h</sub> = Avg. hemispherical illuminance [lx]

the luminance coefficient for diffuse illumination (equation 8). The coefficient for diffuse light is a parameter describing how bright the road surface is.<sup>34</sup> Danish roads are normally medium bright and the coefficient can be given

by approximately:  $Q_d = 0,078 \frac{cd}{m^2 lx}$ <sup>30</sup>

Illuminance calculation: The average hemispherical illuminance is found by multiplying the average illuminance on a horizontal surface by the hemispherical factor (equation 9). This factor gives the difference in measuring between horizontal illuminance and hemispherical illuminance. The Danish Road Directorate gives this factor the value 0,65.<sup>34</sup>

### 7.2.1.1. CALCULATION EXAMPLE – NHEOLIS

A calculation example is presented here. The system is a commercial system on the market today and will be presented later with the additional commercial systems.

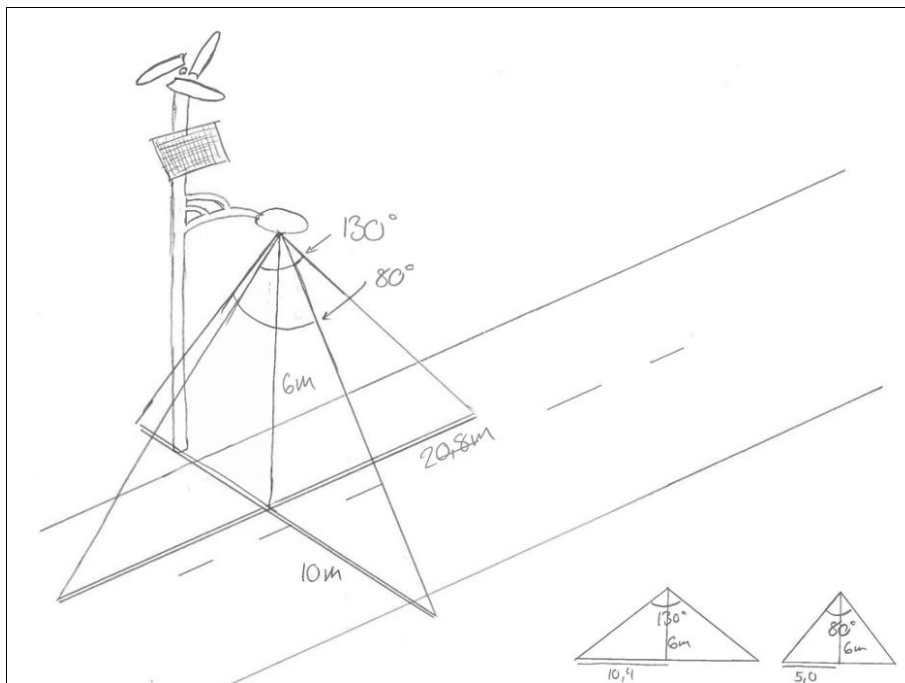

Figure 20 – Nheolis hybrid street light system – Light distribution

The Nheolis hybrid street light (described later in the report) sends out 5.400 lumen in a beam angle of 130° x 80° and the light is placed at a height of 6 m, which can be seen in Figure 20. This gives an average luminance and average hemispherical illuminance as seen below:

$$B = \frac{5400 \text{ lm}}{10 \text{ m} \cdot 20,8 \text{ m}} = 26,0 \text{ lx}$$

$$E_a = 26 \text{ lx} \cdot 0,3 = 7,8 \text{ lx}$$

$$L_a = 7,8 \text{ lx} \cdot 0,078 \frac{cd}{m^2 lx} = 0,608 \frac{cd}{m^2}$$



$$E_h = 7,8 \text{ lx} \cdot 0,65 = 5,1 \text{ lx}$$

From the average luminance of  $0,608 \frac{\text{cd}}{\text{m}^2}$ , it can be concluded that the light source on the Nheolis system delivers enough light to satisfy the luminance demand for the L7B illumination class. The average hemispherical illuminance of **5,1 lx** satisfies the illuminance demand for both the E1 and E2 illumination class.

---

### 7.2.2. UNIFORMITY AND GLARE EVALUATION

The uniformity is the ratio between the lowest and the average illuminance on a given road area. The uniformity can be calculated by a point evaluation, which is not described further in this report, since it requires very specific data on the light source. For a wet road surface the reflection changes from mostly diffuse reflectance to more specular reflectance, which affects the luminance in the different points and thereby the uniformity. The longitudinal uniformity is chosen as the smallest of the ratios between the lowest and highest illuminance that occurs in a driving path.<sup>30</sup>

The evaluation for glare risks for the L class is very advanced and will not be commented further in this report.<sup>35</sup> For the E class the glare is evaluated based on maximum illuminance in the incident angle  $85^\circ$  and the area of the luminous parts of the fixture.<sup>34</sup> A rule of thumb in avoiding glare problems in street lighting, is that by placing the lamp posts with a maximum distance of six times the height of the fixture glare problems can be minimized.<sup>E</sup> According to the Danish Road Directorate this number is five times for traffic streets and seven for local streets.<sup>34</sup>

## 8. MARKET STUDY OF COMMERCIAL HYBRID SYSTEMS

A market search on existing hybrid street light system has been done with an internet based search. Furthermore emails have been sent out to suppliers to source more detailed information. About half of the suppliers answered back, but with very varied information.











The systems found are presented in this chapter together with analysis of the different elements of the systems. Before this a study of the data quantity is performed. This is because the initial result of the market search was to categorize the hybrid systems according to the road regulatory given in the previous chapter. With the scarce amount of data found, this was not possible. Instead of the categorization an analysis of the different elements in the hybrid systems is performed.

### 8.1. COMMERCIAL HYBRID SYSTEMS TODAY

The hybrid systems found on the market today are described. Most systems are from Chinese suppliers along with two US suppliers, two Canadian, two Korean and one French supplier. No commercial hybrid systems were found from any Danish suppliers.

Overall information is gathered on 29 different hybrid systems, where some suppliers have more than one commercial hybrid system. Some systems are not taken into the analysis, because almost no data existed on the systems. All the commercial systems are named after the supplier and all can be seen in Figure 21 below:

<p>Windela</p> 	<p>Urban Green Energy</p> 	<p>Urban Green Energy</p> 	<p>Solavero</p> 
<p>JL CarbonFree Energy</p>	<p>JL CarbonFree Energy</p>	<p>Remote Hybrid Systems</p>	<p>Cygnus Power</p> 

 <p>Carbon Free Energy Co. carbonfreeenergy</p>			
<p>Cygnus Power</p> 	<p>United Electricity</p> 	<p>AnHui Hummer Dynamo</p> 	<p>Hefei Liuming New Energy Technology</p> 
<p>Hefei Liuming New Energy Technology</p> 	<p>Hefei Liuming New Energy Technology</p> 	<p>Everlast Lighting</p>  <p>State Mini Storage</p>	<p>Suneco</p> 
<p>Nheolis</p>	<p>LinkonePower</p>	<p>MacroWind</p>	<p>Nanjing Supermann Industrial</p>









			
<p>Nanjing Supermann Industrial</p> 	<p>Jiangsu KingSun</p> 	<p>Ningbo United Lighting</p> 	<p>Shenzhen TIMAR windenergy</p> 
<p>Shenzhen TIMAR windenergy</p> 	<p>Link Light</p> 	<p>Green Power Generator</p> 	<p>Windrex</p> 
<p>Windrex</p> 			

Figure 21 – Commercial hybrid systems <sup>6</sup>

Generally the commercial systems are quite similar with the four components: lamp, PV, wind turbine and battery put together on a pole. More variety is seen from concept ideas, where e.g. PV and turbine have been integrated.<sup>6</sup> Since these systems are still on the drawing board and not realized, they are not taken into account – since no factual information can be obtained. The biggest differences in the commercial systems are in the wind turbine design. Both horizontal and vertical axis rotors are used. The vertical systems are with the rotor designs: H-rotor, Savonius and Darrieus. Additionally various sizes and numbers of silicon photovoltaic panels are used in the systems, whereas LED lamps of different wattage is the typical technology for light. The largest difference are mainly seen for the wind turbines, which most likely due to the fact that most systems are produced by companies normally producing wind turbines.<sup>1</sup>

8.2. DATA

As mentioned, one of the intentions for the market research was to categorize the systems according to how they could perform on the Danish roads and thereby live up to the regulation of the illumination classes. This was however not quite possible, due to very scarce information from the suppliers of the hybrid systems. To be able to evaluate the performance according to the illumination demands, information is required about the luminous flux and the distribution of the light. Information on both of these two parameters was only found on four systems, which is not enough for proper categorization.

The data found on the hybrid systems are briefly described to show the quantity of data that have been available for the following analysis. What data points was found on the different systems can be found in Appendix A.

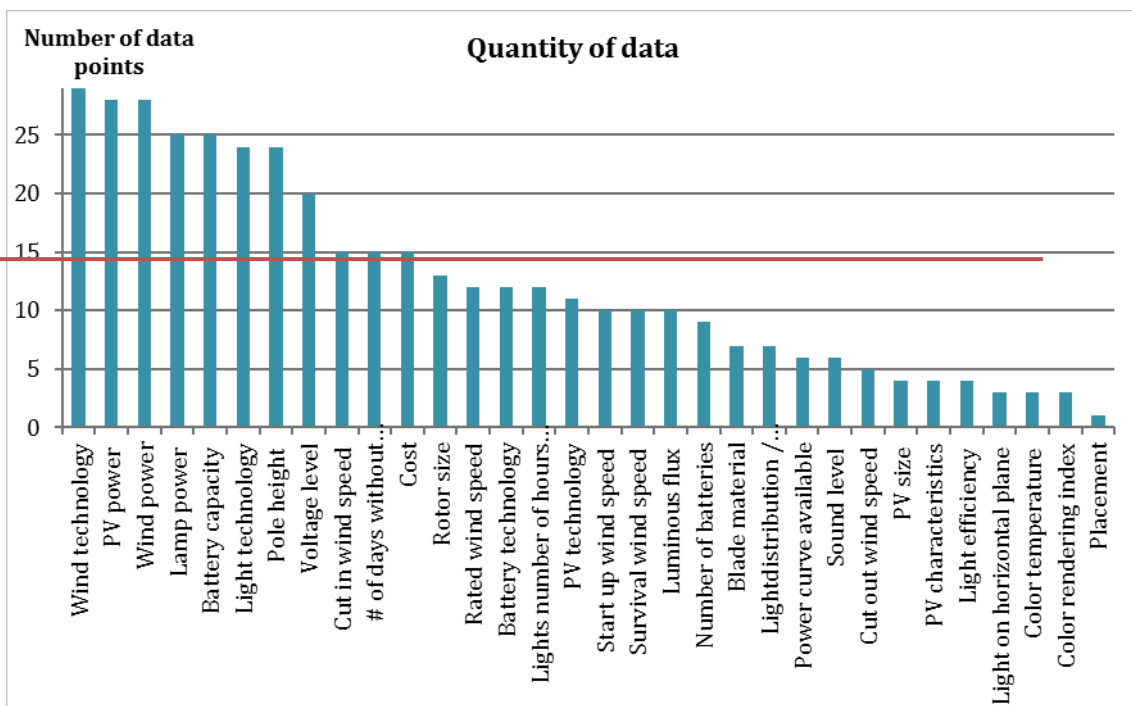

Figure 22 – Quantity of data collected from suppliers. Subjects with most data points are listed first. The yellow line indicates that 50% have given data.

Above in Figure 22 the number of data collected on each subject can be seen. The yellow line indicates that 50 % of the suppliers have given information on their system. For 11 subjects more than 50 % of suppliers provided information, while for 21 subjects less data have been given. Only the wind rotor type is known for all systems, which is mostly only given by pictures as seen in Figure 21. From Figure 22 it can also be seen that most data have been given for the PV power, the wind power, lamp power, battery capacity, light technology and pole height. These subjects have the most comprehensive information for the analysis. Subjects with just above 50 % data input are voltage level, cut-in wind speed, continuous days without sun or wind, and cost. These subjects have sufficient data for comparison. Subjects that have ten data points or more can be compared to some degree. Subjects that have less than ten data points are difficult to compare and analyze. Subjects with few data points are the luminous flux and light distribution. These are needed for illumination evaluation, together with color temperature and color rendering index. All these are required criteria to be allowed on the Danish roads. For comparison and analysis of the PV panels, crucial information is missing on PV technology and PV size, where only four have replied. The wind turbine comparison is also highly compromised as the rotor size and rated wind speed have data on less than half and only six suppliers have provided the power curve.

The absence of data also compromises some of the given data. A critical example is the rated power output of the wind turbine, where information was found for 28 of the 29 systems, but only for 12 systems the rated wind speed was given. To be able to use and compare the systems on the power output, assumptions on the rated wind speed must be made for the remaining 16 systems. The rated wind speed can however be estimated since 8 of the 12 systems had 12 m/s as rated wind speed. This gives a very large uncertainty due to the significant influence the wind speed has in the power calculation, as seen in the power equation (4) earlier in the report.

Overall the subject with most detailed information is the wind turbine, which is very likely caused by the fact that 10 of 21 suppliers are originally wind turbine suppliers, where the remaining 11 suppliers are spread on light, solar and a mix of other areas. A reason for the scarce information is that some data is only found online and suppliers will not give out all information online. Another very plausible reason is that the suppliers do not know the technical details.

For the reason that data is missing to categorize the systems according to the Danish illumination classes, it is decided not to perform the categorization. Instead an analytical comparison is made of the different parameters of the systems.

### 8.3. ANALYSIS

The different parts of the hybrid system are analyzed separately and then afterwards compared overall.

#### 8.3.1. LAMP

On the lamp system the most given information is the power consumption. The range is from 30 to 150 W, which is a very large range. Most are in range from 40 to 70 W, this accounts for 18 of the 25 systems. One system has given the power to be 30 to 180 W and is not included in this evaluation. 22 of the 24 lamp systems use LED lighting technology.

The luminous flux is given for ten systems and here the range is from 3.000 to 8.400; the systems at the maximum and minimum of this range are from the same supplier. All other systems (the eight remaining) have a luminous flux of between 5.000 and 7.000 lumen. The efficiency of the lamps has a range from 84 to 120 lm/W, which is fairly similar to the efficiencies given by Philips Lighting.<sup>F</sup>

The light distribution is given by a total of seven suppliers in very different manners. One supplier, Everlast, has given photometric graphs that show the exact spread of the light. This information is important in a final evaluation of the light before it is installed and is needed to perform calculations on uniformity. The remaining six give the light distribution in different manners: square areas, radius, beam angle and the distance between the lamps.

As mentioned the luminous flux together with the light distribution are needed to evaluate the systems according to the Danish regulatory demands. Also a given illumination level can be used, but as seen in Table 6, these given values can maybe not be trusted. This is seen in the Nheolis values, where the given illumination level is 28 lx on a horizontal surface and this is previously calculated to only 7,8 lx. Therefore the luminous flux and light distribution is preferred to find the illumination level. Both of these parameters are given for four systems – Windela, Everlast, Linkone Power and Nheolis, which was used as calculation example in the previous chapter. These are listed in Table 6 together with the regulation and demands for color temperature and CRI.

	Windela	Everlast	Linkone	Nheolis	Regulation and demands
<b>Illumination level (given)</b>	Average hemispherical illumination: 18 lx		Average hemispherical illumination: 8 lx	Average hemispherical illumination: 28 lx (h = 6 m) 16 lx (h = 6 m)	Average hemispherical illumination: 2,5 lx E2 illumination class
<b>Illumination level (calculated)</b>	Luminous flux and square area	Luminous flux and photometric graphs	Luminous flux and radius of light	Luminous flux and beam angle Calculated: 7,8 lx	Luminous flux and light distribution
<b>Color temperature</b>	5.600 K	5.000 K		3.000 - 3.500 K 4.000 - 4.500 K 5.000 K 7.000 K	3.000 K
<b>Color rendering index</b>	> 77	82 - 85		> 75	Regulation: > 50 Preferably: > 80

Table 6 – Commercial systems and regulation plus demands for Danish street lighting.

Color temperature and color rendering index are very important factors in describing light and both have criteria set by the Danish road regulations and the municipality of Copenhagen. Three systems have given the color temperature; all three are from the group that has luminous flux and light distribution given and given in Table 6. Two systems have color temperatures of 5.000 and 5.600 K, which is far above the criteria set by Copenhagen of 3.000 K. The Nheolis system, with a color temperature of 3.000 to 3.500 K, can be chosen. The same three systems have given the color rendering index. With the values >77, 82-85 and >75 they all live up to the regulatory demand of above 50, but only one, Everlast lighting, lives up to Copenhagen's demand of above 80. This concludes that no single system meets all the criteria set by the municipality of Copenhagen. The Nheolis system has the correct color temperature and lives up to the regulatory demands for color rendering index and a bit lower color rendering index than wished by the municipality. In the calculation example under street lighting it was seen that the system lives up to the demands for

illumination class L7B, E1 an E2. This system is in terms of light qualifications acceptable and therefore taken further on in this project.

### 8.3.2. PV

The PV panels on the systems range from 45 to 360 Wp, while most of the panels are between 100 to 200 Wp; this can be seen in Figure 23. All the systems where data has been given on PV technology are crystalline Silicon panels. Within these, four are monocrystalline and five are polycrystalline.

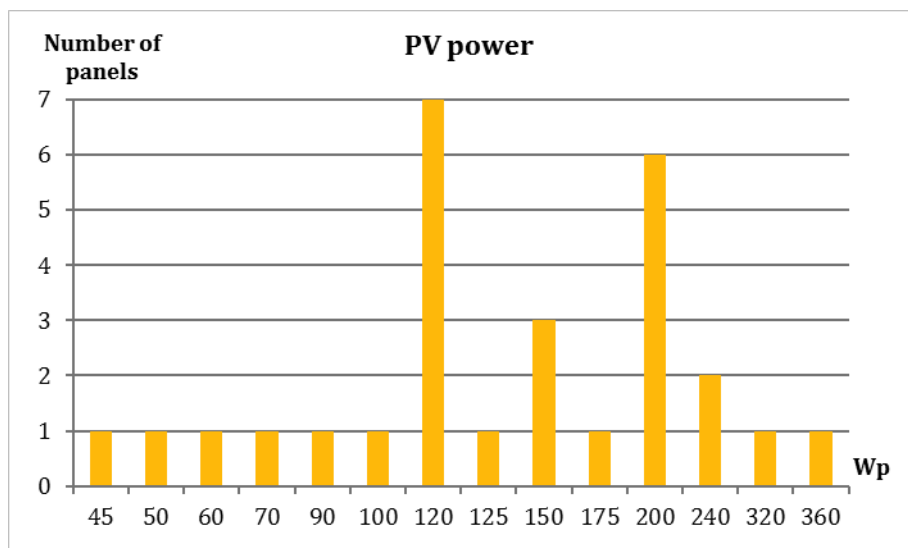

Figure 23 – PV power – Number of panels at different Wp

The efficiency can, as mentioned in the theory chapter, be given in two ways. The most simple is watt peak per square meter, from where the module efficiency can easily be found. Watt peak per square meter is found for the four systems, where the size of the PV is given. The four systems only represent three different PV modules, since the two modules for Urban Green Energy’s two systems are the same. The efficiencies are given below in Table 7 and it can be seen that Urban Green Energy has the highest efficiency with 128 Wp/m<sup>2</sup> (12,8 %). Since only Nheolis has given the PV technology, not much can be concluded between mono- and polycrystalline Silicon.

	Urban Green Energy	Windela	Nheolis	Everlast
<b>Efficiency</b>	128 Wp/m <sup>2</sup>	117 Wp/m <sup>2</sup>	100 Wp/m <sup>2</sup>	
<b>Fill factor</b>	0,71		0,71	0,687

Table 7 – Efficiency and fill factor for commercial hybrid systems

The fill factor also gives the efficiency of the module, which can be calculated for the modules where the characteristics are given. This is given for three systems and can also be found in Table 7. The Urban Green Energy and Nheolis panel fill factors are both 0.71, whereas the Everlast panel has a fill factor of 0.687, which is lower this panel can therefore not compete with the efficiency of the Urban Green Energy PV panel. The technology of the Urban Green Energy panel is not given, but is most likely crystalline Silicon, either mono- or polycrystalline.



### 8.3.3. WIND

The wind turbines are, as previously stated, distributed on the turbine technologies: horizontal turbine, Savonius, H-rotor with straight and twisted blades and Darrieus with a small Savonius turbine combined. Among the 29 hybrid systems, 14 have horizontal rotors, six have H-rotor, where two have twisted blades, six have Savonius and three Darrieus with a small Savonius combined. The fact that about 50 % of the systems have horizontal rotors is not strange, since this is the classic rotor type.

The range of the wind power output is 100 to 600 W and can be seen in Figure 24 together with the rated wind speed. From the graph it is seen that by far the most turbines have a rated power output of 300 and 400 W. The rated wind speed is between 11 and 14 m/s, but where 66 % have 12 m/s given. The range of power output is evenly divided over the different rotor systems.

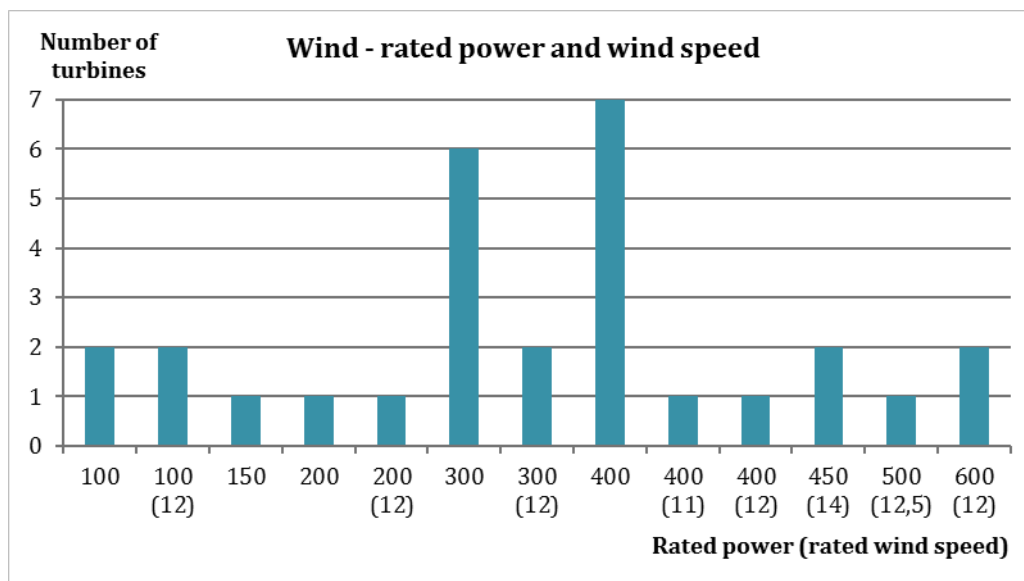

Figure 24 – Rated power and wind speed for the different turbines

The swept area has a range from above 5 m<sup>2</sup> to just below 1 m<sup>2</sup>, but the majority are between 1 and 2 m<sup>2</sup>, this can be seen in Figure 26. The power output in relation to the rotor size will be compared through the efficiency value Cp, which was introduced earlier in the theory chapter. The found Cp values on different rotor types can be seen in Figure 25.

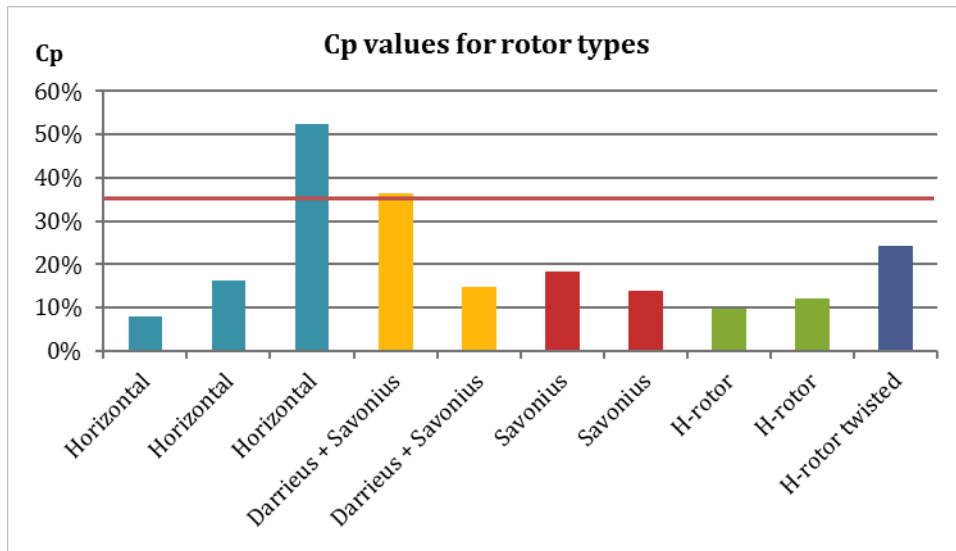

Figure 25 – Cp values for the different rotor types

The Cp values, which are found from equation 5, range from 8 % to 52,6 %. 52,6 % is a very high value and over the realistic limit for small turbines. The realistic limit has a maximum of 35 % and is in Figure 25 and Figure 26 given by the yellow line. In both figures it can be seen that two rotors are clearly above in the realistic maximum, and these are therefore not taken into account. The remaining best performer is Urban Green Energy’s twisted H-rotor, which is a part of both of Urban Green Energy’s systems. The other rotor types perform quite similarly, but with both H-rotors at the lower end of the scale. The Cp values are very spread and do not conclude much in relation to rotor type.

Figure 26 below shows the relation between the Cp value and the size of the rotors. When the two systems above the limit and the single large rotor are not taken into account, a trend can be determined (red), which shows that the larger rotors tend to perform better than the smaller. The fact that larger rotors have higher efficiency is also stated by Christina Beller<sup>13</sup> and that when considering small turbines, the horizontal rotors do not have much higher efficiency than the vertical axis rotors, which is also seen in Figure 25 above.

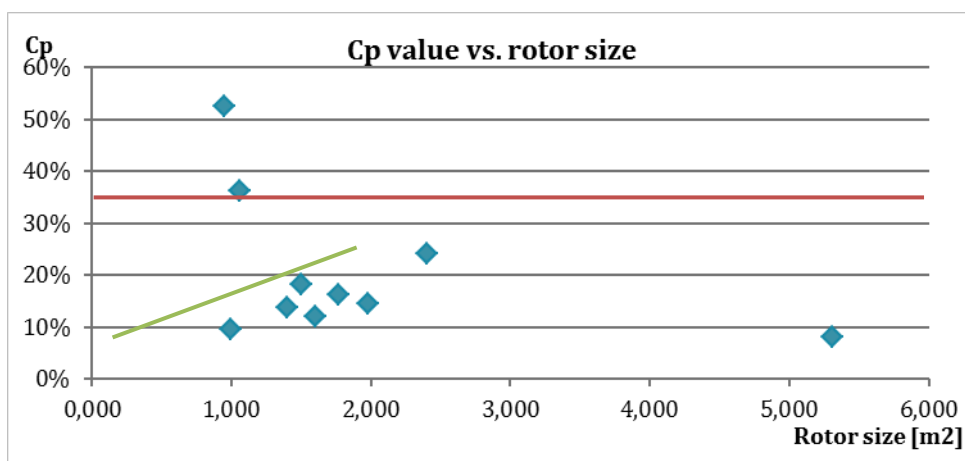

Figure 26 – Cp value versus rotor size

The Cp values found are only for rated wind speed, since the Cp value change for different wind speeds. A more detailed evaluation can be made from the power curves. These are however only given for four of the systems. These can be seen in Figure 27.

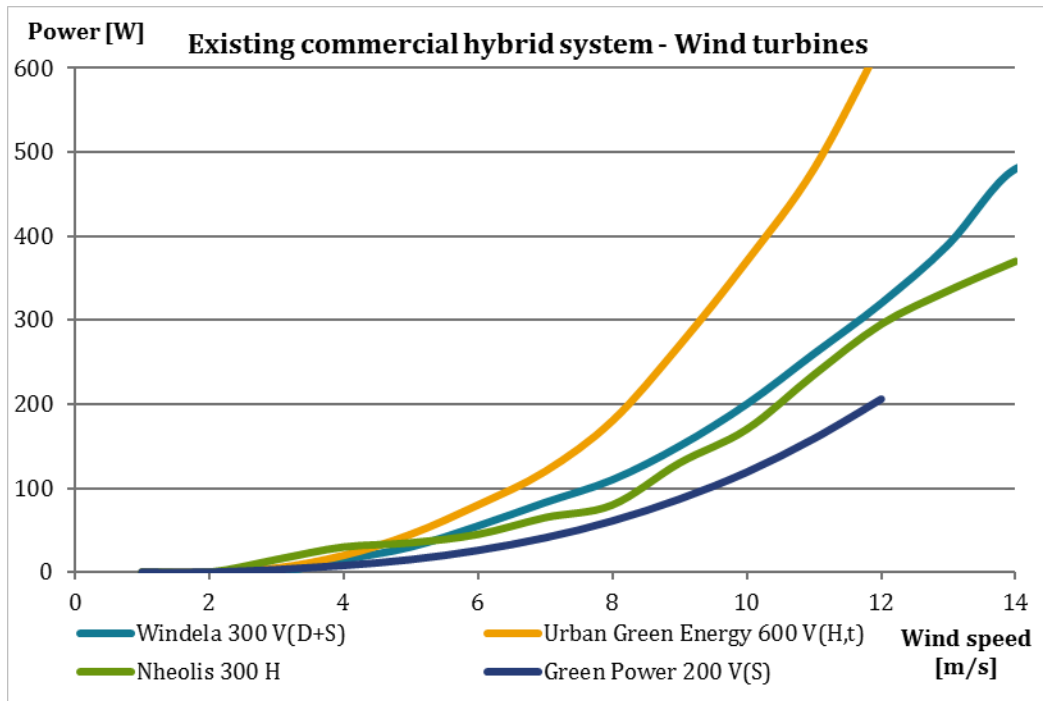

Figure 27 – Power curves – Number: rated power, V: vertical, H: horizontal, in parenthesis: D: Darrieus, S: Savonius, H,t; H-rotor with twisted blades

The power curves in Figure 27 clearly show that some rotors perform better at lower wind speeds, while others are superior at higher wind speeds. Due to the urban environment, the lower wind speeds are more important. A zoom on Figure 27 gives Figure 28.

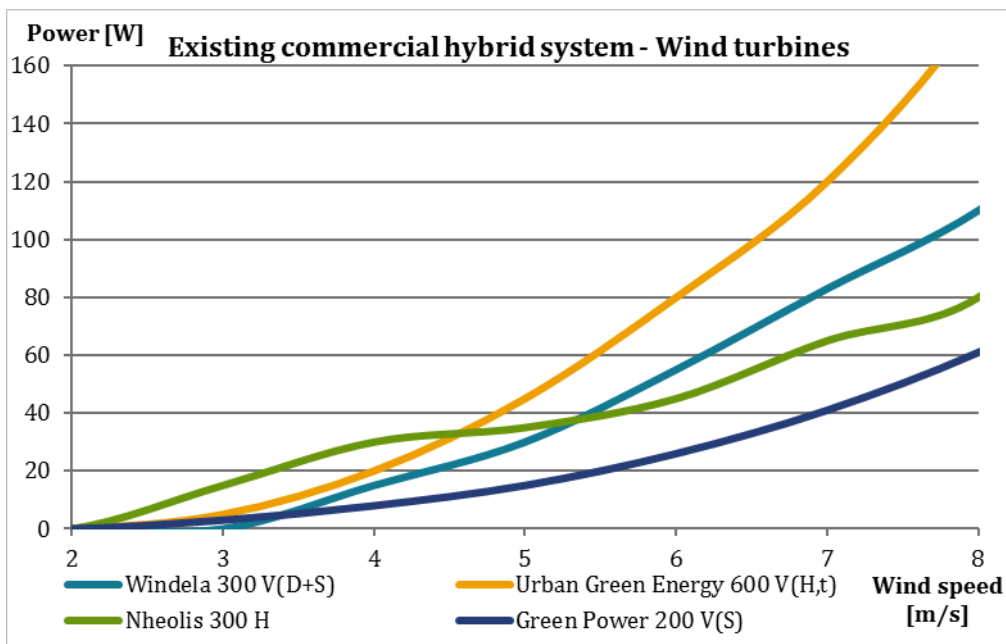

Figure 28 – Power curves at the wind speeds 2 – 8 m/s

Figure 28 shows that The Nheolis system is superior at the lower wind speeds, but that Urban Green Energy is better at wind speeds of 5 m/s and upwards.

A factor that is also important in the comparison of the wind turbines is the cut-in wind speed, which is the wind speed where the generator plugs in and starts producing power. This is important again because of the low wind speeds in the urban environments. On 15 systems the cut-in wind speed is given and the range is from 1.3 to 3.5 m/s, where both range points are on H-rotors. It is generally seen that the rotors with low cut-in wind speeds are also smaller. An exception is the two Cygnus rotors, where the larger rotor has a lower cut-in wind speed.

#### 8.3.4. BATTERY

The range of the battery capacities is from 100 to 600 Ah and with voltage of either 12 or 24 V. The range of kWh is from 1,2 to 6 kWh with an average of 3 kWh. The technology mostly used is lead-acid batteries. The number of continuous days without wind or sun has a range from 3 to 18 days and is not particular related to battery capacity.

#### 8.3.5. OVERALL COMPARISON

This overall comparison is a conclusion on the separate analysis and a comparison of the systems across the different technologies.

The general conclusions on the different technologies are that there generally are quite big spans in the values presented. The PV panels are Silicon panels with the most efficient to be from Urban Green Energy. The wind turbine evaluation found that the efficiencies between the different rotor types were not so different, but related to the size of the turbine. Again it was the Urban Green Energy's H-rotor with twisted blades that excelled above the others. As was stated multiple times, the lighting has very scarce information in relation to what is needed for classifications. It was however found that the Nheolis system was very close to meeting the demands for the local streets in

Copenhagen. A conclusion from the lighting technology is that the LEDs have advantages over the other technologies, since LED was used in 92 % of the systems.

The different power parameters are set up for the different systems in Figure 29 below. They show that there is no true pattern between the sizes of the technologies. The ones with high wind output can have low or high light consumption and the same for the PV output, which can also not be related to the wind output or the battery capacity needed for the system. Even the two systems with the highest battery capacity have very different need for lighting power. No overall categorization is made, since the systems have shown to only be comparable on the different technologies and not as a whole.

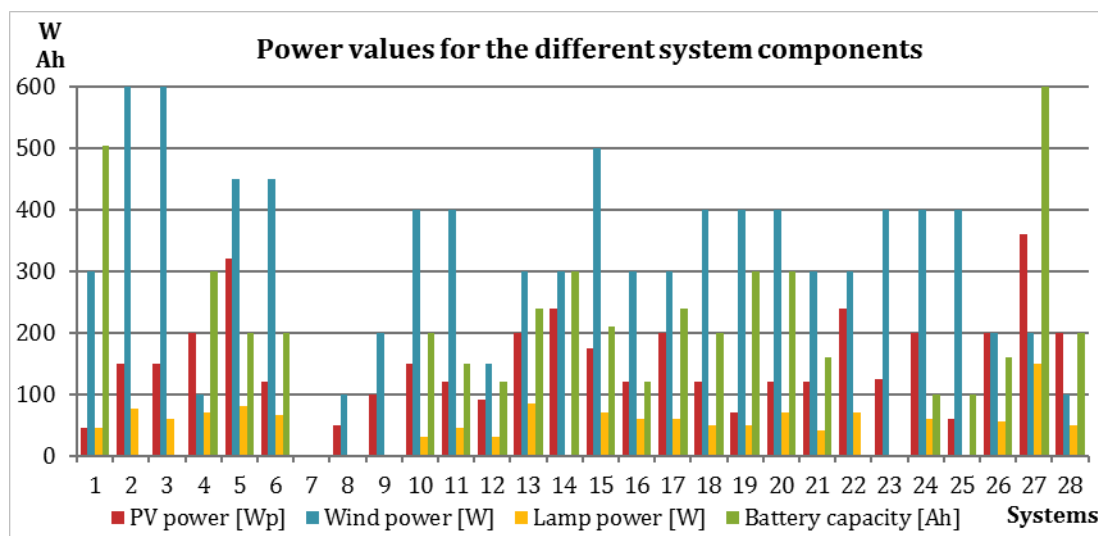

Figure 29 – The power of the different technologies. The left axis represent both watt and ampere hours

A last parameter to be compared is the cost. The cost of the hybrid systems ranges from 9,600 to 85,000 kr. This is a very large span. There is no specific pattern in the costs compared to the other data given on the systems. A general interpretation is that the systems with horizontal wind turbines are cheaper with all seven systems being below 18,000 kr., whereas six of the remaining eight vertical turbine systems lie above 20,000 kr.

The Nheolis system was the only acceptable system in regard to the lighting regulation and demands from the municipality of Copenhagen. Therefore the system is taken further on in the project as reference from the commercial products.

The Urban Green Power product seems to be the most mature on the marked and seems to have a growing business based on their products. It is very difficult to evaluate if the companies are having commercial success and growing market based on the available information.

## 9. IMPLEMENTATION OF 4 HYBRID SYSTEMS AT RISØ CAMPUS

### 9.1. INSTALLATION OF THE COMMERCIAL HYBRID SYSTEM FOR TEST AND BENCHMARKING

The following hybrid systems was chosen to buy and test on DTU RISØ Campus having a test field for wind turbines and solar panels.

- China Green Power
- United Electricity
- Urban Green Energy
- Nheolis

The background for the choices were many. The Nheolis seems to be the only system to fit the lighting requirements for the Municipality of Copenhagen and was chosen on that background. The China Green Energy has a savonius rotor, which is drag driven and therefore due to safety reasons a good choice since it newer rotates faster than the wind speed. It is also the preferred choice astatically by the municipalities participating in the project. It was also interesting to test systems with different rotor types.

The systems are shown by images from the manufacturers in Figure 30 below.

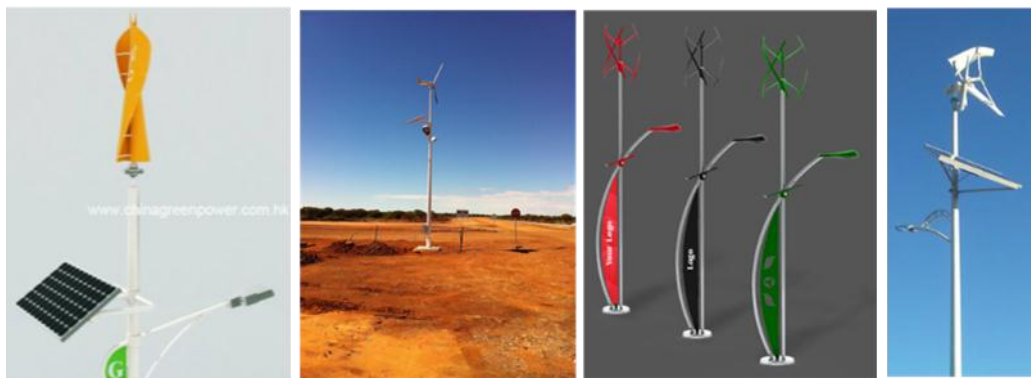

Figure 30 Hybrid systems bought by international manufacturers

In the table below the hybrid systems parameters are listed.

	China Green Power	United Electricity	Urban Green Energy	Nheolis
<b>WIND (power)</b>	200 Wp	400 Wp	600 Wp	300 Wp
<b>turbine height</b>	7.0m	8.0m	11.0m	9.0m
<b>turbine type</b>	Savonius	HAWT	twisted VAWT	3D HAWT
<b>turbine area</b>	1.4sqm	3.8sqm	2.4sqm	1.77sqm
<b>SUN (PV power)</b>	200 Wp	180 Wp	150 Wp	200 Wp

<b>PV height</b>	5m	6m	6m	7.5m
<b>PV type</b>	Poly Crystalline	Mono Crystalline	?	Poly Crystalline
<b>PV area</b>	2sqm	1.5sqm	1.17sqm	1.0sqm
<b>PV tilt</b>	45deg	45deg	45deg	30deg
<b>LED / Light</b>	60 W LED	30 W induction	77 W LED	60 W LED
<b>LED height</b>	6.0m calc	8.0m calc	?	6.0m calc
<b>STORAGE</b>				
<b>battery capacity</b>	0.96kWh	2.40kWh	2.10kWh	1.44kWh

Table 8 Parameters for the hybrid systems

The systems was installed at DTU RISØ Campus during the summer of 2012. Pictures of the systems are shown below:



Figure 31 Installed commercial hybrid systems

It should be noted, at the deliveries of the systems had many missing components, and only for the Nheolis system was all the required components available. A large amount of welding work was required to assemble the other systems and custom bracket needed to be created. The installation manuals was of quite low quality for all the systems and an impressive amount of it was in Chinese language. The Urban Green Energy turbine had to have changed a bearing already after a week of work and for most of the system really low quality materials seems to have been used for the mechanical constructions. Corrosion also seems to be a serious problem for all the systems – the Urban Green Energy system seems though to be of highest quality on this topic but the price of this system was also close to the sum of the other 3.

## 9.2. DATA LOGGING

On each mast a minicomputer was installed, which measures the current and voltages in the system to and from the solar panels, the battery, the wind turbine, and the light source. These parameters are measured simultaneously making it possible to map the energy flow. The minicomputer on each mast has a wireless connection to a PC and every 10sec it sends measured data to the PC. Along with lampposts is also a Solar Radiation Sensor (pyranometer) which every 10 sec measured the irradiation from the sun (W/m<sup>2</sup>) and the ambient temperature (°C). The PC sends all measured data to a SQL server where the measurement data are later retrieved for data analyses. The wind data is also measured in different heights on the field and send to the database. The data architecture is shown below in Figure 32

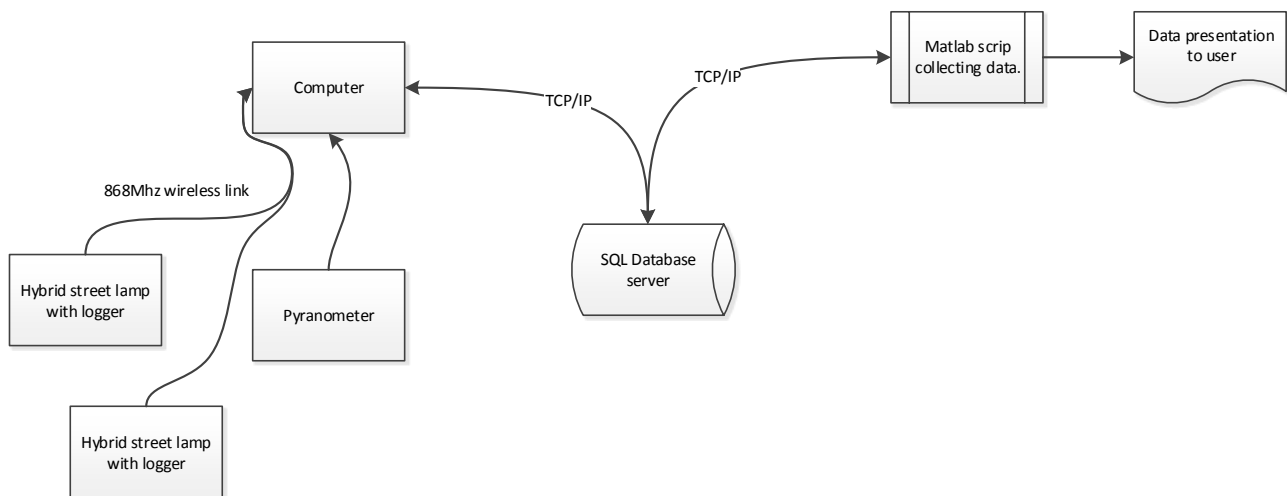

Figure 32 Data architecture from the measured parameters of the hybrid street lamps



## 10. MATHEMATICAL MODEL SYSTEM OF HYBRID SYSTEMS

### 10.1. DESCRIPTION OF THE MODEL

The time-marching computational model for hybrid street lighting systems comprises several modules corresponding to various components of hybrid systems. These are: the wind turbine, PV panel, battery and LED. Given the properties of modeled components and input such as wind climate or solar irradiance, the model estimates energy gain. The produced energy is transferred either to the LED to produce light or stored in the battery. The following sections provide a more detailed description of the modules comprised in the computational model. To present how the model works, three luminaries with various wind turbine types were modeled. All the parameters of the modeled luminaries, other than wind turbine types, as well as solar irradiance and wind climate were assumed identical. The modeled luminaries comprised wind turbine types used in actual commercially available hybrid systems. However, the remaining parameters were not meant to represent any specific commercially available hybrid system but were meant to fall in the regime representative to most of the devices available on the market. The model is based on MATLAB modules build on theory for each technology and handling weather data and other input and calculating the results based on iterative and interconnecting equations. A flow diagram of the model is shown on Figure 33

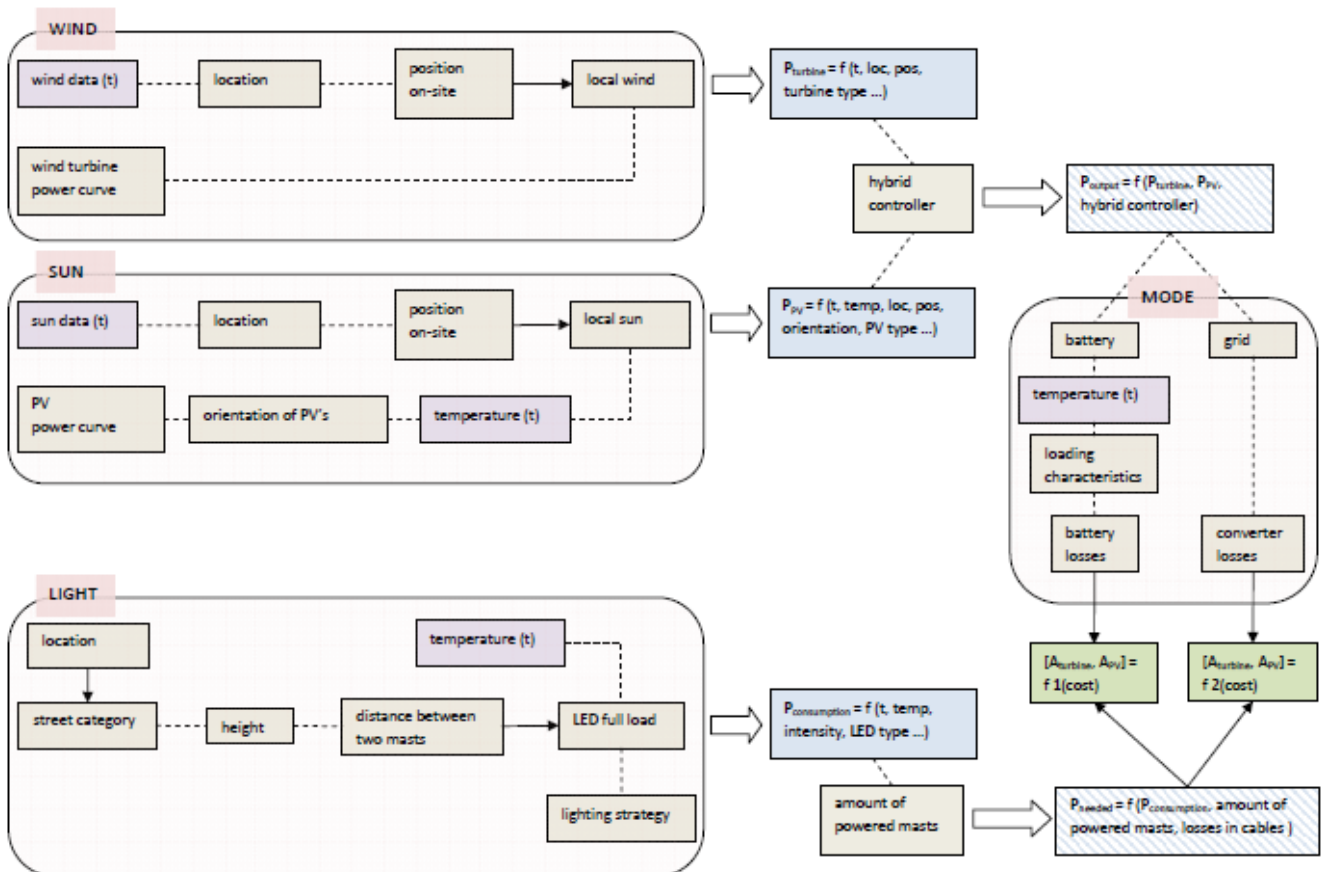

Figure 33 Flow diagram of the mathematical model of a hybrid system

## 10.2. MODELING THE URBAN WIND CLIMATE

The wind climate in urban areas depends on several parameters. One very important parameter is the location of a city. The energy potential of a city can be approximated e.g. by using The European Wind Atlas<sup>36</sup> which describes the wind climate in Europe, based on several wind measurements and topologic descriptions. If the landscape was regular and smooth with no changes in roughness the wind energy could be estimated with rather good accuracy by using models as those described by Troen and Petersen<sup>36</sup>. The situation is unfortunately much more complex in the case of a city where because of obstacles like buildings the wind turbine will operate below the so called boundary layer in which the wind speed could be approximated in a relatively easy manner and in a way that has been validated throughout many years. Also, the typically irregular pattern of houses in a city makes the prediction of the wind energy challenging. This challenge is e.g. described by Beller<sup>37</sup>, Dadde and Plate<sup>38</sup>, and Wieringa, et al.<sup>39</sup>.

In Copenhagen, as the city of choice, measurements on a few sites have been carried out and three of them were analyzed to gain an overview of the wind characteristics in the city. In the present work, several luminaries equipped with different types of rotors were simulated in wind climate representative to different urban environments with emphasis on one of the new districts in Copenhagen, comprising 1-2 story single family buildings with gable roofs (E2). In order to simulate the luminaries as working in these districts, time series of wind speed measured at a location 20 km north of Copenhagen (Sjælsmark) was delivered by the Danish Meteorological Institute ([www.dmi.dk](http://www.dmi.dk)). This was the closest available location from which a complete year-long time series was available. Then, this data was corrected to account for the specific urban landscapes – building height and density – using the roughness step method described by Beller<sup>37</sup>.

## 10.3. MODELING THE WIND TURBINE

Prediction of the power output from the wind turbine requires the knowledge of the power efficiency of the rotor. The power efficiency is very dependent on the rotor concept and the size of the rotor. Traditional large rotors are so called horizontal axis wind turbines with three blades. They are lift driven which means the blades are sucked through the air because of the suction pressure close to the leading edge of the blades. This mechanism is also used for some vertical axis wind turbines as e.g. the Darrieus type or H-type. For the lift driven concepts, the lift-to-drag ratio is crucial for the overall rotor performance.

However, in contrast to the large modern rotors, as e.g. the 5 MW sweeping through 12000m<sup>2</sup> of air or more, the size of the urban turbine is very small. They might only sweep through 2 m<sup>2</sup> of air as in the case for the present simulated rotors. This difference in size is also reflected in the chord lengths of the blades and thereby on the Reynolds number. With the much lower Reynolds number, the lift-to-drag ratio becomes much lower and therefore the power efficiency decreases significantly, as described by Bak (Bak, 2008)<sup>40</sup>. For this reason and for the reason of safety and aesthetics it is of interest to explore other possible concepts in the current project.

The modeling of the luminaries with the following turbines is described in the present report: vertical-axis twisted Savonius (*Green power* – see Figure 34 (a)), three-blade horizontal-axis (*United Electricity* – see Figure 34 (b)), and vertical-axis three-blade helical H-rotor (*Sanya* – see Figure 34 (c)).

These turbines are actual components in luminaries manufactured by the corresponding producers. Each of these turbines is of different size. However, in the present work, each swept area was scaled in the analysis to be of 2 m<sup>2</sup> for

a better comparison. The rotor hub height in all three cases was assumed to be 8 m. Also the remaining parameters of the simulated luminaries were assumed identical. These are described in the following sections.

Simulation of the turbines was a simple table lookup based on the producer-supplied power curves presented in Figure 35. Note that according to Mertens (Mertens, 2009)<sup>43</sup> producer-supplied power curves concerning small turbines are often poor indication of the actual performance of the turbines. Therefore, in order to perform more accurate simulations, power curves should be verified experimentally. Especially the power curve of the horizontal axis turbine, which despite the turbine’s small size and therefore low lift-to-drag ratio operates relatively close to the Betz limit just above the cut-in wind speed, craves for verification. Experimental verification of the power curves, being part of the current project, is described further in the present report.

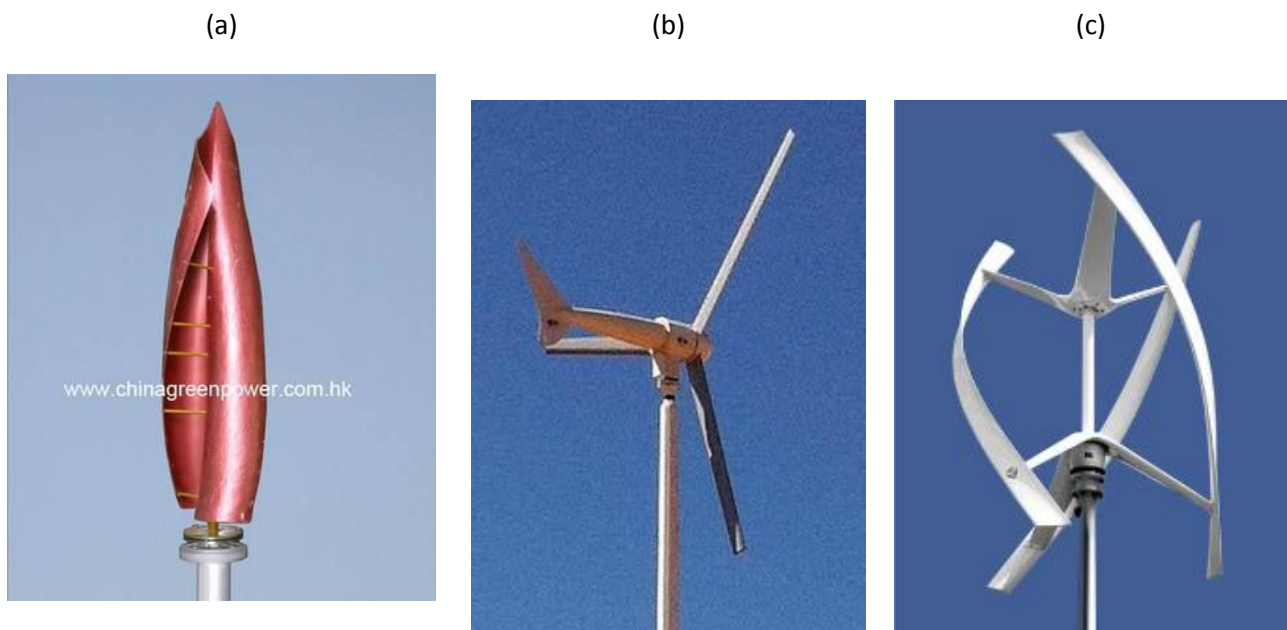

Figure 34: (a) *Green Power* vertical-axis twisted Savonius rotor (b) *United Electricity* horizontal-axis three-blade rotor (c) *Sanya* vertical-axis three-blade helical rotor

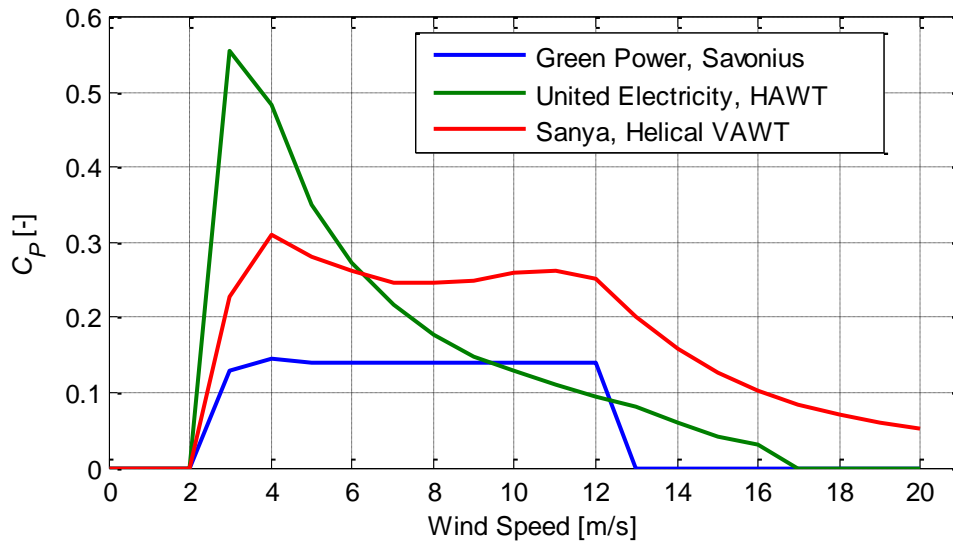

Figure 35: Producer-supplied power curves concerning the three simulated rotors

#### 10.4. MODELLING THE LIGHTING

The energy consumption by the LED lighting is modeled by calculating the amount of power needed by a given lighting system at a given time, this power is then subtracted from the energy production of the system or from the battery over the specified time period. The power is calculated from the luminance and illuminance levels required by local and national authorities, the efficacy of the lighting system, the size of the area to be illuminated and the luminous efficacy of the system. This focus of this study has been Danish street lighting but the European regulations on street lighting is very similar to the Danish regulation. Roads and streets, intersections etc. is separated into street classes according to the amount of traffic, and general environment. (See Table 8 from the Danish Street lighting regulation)

The power needed for lighting  $P$  is, in its simplest form, given by this equation:

$$P = \frac{AE_v}{\eta U} \quad (10)$$

Where the power  $A$  is the illuminated area,  $E_v$  is the required illuminance level on said area,  $\eta$  is the luminous efficacy of the lighting system and  $U$  is the utilization factor i.e. the fraction of light from the lamp falling on a hemispherical detector in the regulated area. It should be noted that these quantities in many respects are difficult to optimize: The illuminated area and required illuminance will often be decided by the municipality, typically from the road width, traffic load and armature spacing most calculations in this project have been done for 13x30 meter squares. The luminous efficacy is limited by what is available in the high end LED marked (up to around 100 lm/W ultimo 2012). The efficacy of the lighting system is measured in lumen/watt and is affected by many factors, such as the LED chip light conversion efficiency which is again affected by the operating temperature, the spectral power distribution, loss from optics and reflectors. The utilization factor will be limited by how well the light distributing optics matches a particular road segment these range from 90% to below 50% for some types of luminaires. Even though many parameters are

set for the energy consumption, it worth noting that for each percent it can be lessened; the requirements for energy production by photovoltaic- and wind systems and capacity of the battery can be reduced. This could lead to smaller wind turbines or smaller PV elements or better resilience for the systems against periods with low energy potential.

Road class	Average illuminance requirements [lux], [lm/m <sup>2</sup> ]
E1 high, dense buildings	5,0
E2 spread, low building	2,5
LE4/LE3 bigger streets and crosses	15
L2/LE very big roads	30

Table 9 Hemispherical illuminance (on the traffic area as a whole)

#### 10.4.1. OPTIMIZATION POSSIBILITIES

In order to decrease energy consumption there are several areas where possible changes can be made in order to lessen the requirements on the entire system. The foremost possibility and the one with a very large potential lies in the selection of highly efficient LEDs. The LED chips have seen a dramatic increase in efficiency, with a doubling every three years, and this increase is projected to continue for several years (DOE, 2010<sup>42</sup>). If this rapid development is taken into account, by for instance specifying a new system after which LEDs will be available at the time of production, then the requirements could be lessened significantly.

Another possibility for increasing efficiency is to increase the correlated color temperature of the street lighting. Although there can be aesthetical problems with the bluish light, lighting with high correlated color temperature can be around 20% more energy effective than light with low correlated color temperature. Another consideration is if current measures of useful light are appropriate in the setting of low level street lighting. The efficacy of the spectral power distribution is conventionally measured in lumen/watt however at low light levels it might be more appropriate to use the mesopic photometric system proposed by the CIE (CIE, 2010<sup>41</sup>). Using the luminous flux to determine efficacy favors spectral emission around the 555 nm (green) while the mesopic correction favors light emission around 505 nm for decreasing light levels. By targeting a specific Mesopic illumination level the energy requirement can be decreased further without sacrificing visual performance in low light levels.

Another way to decrease power consumption is to time and control the lighting levels. So that for instance the lighting level is decreased in periods of small traffic loads or in conditions of snow covering or moon light.

#### 10.5. MODELING THE PV PANEL

The energy supplied to the system by the solar modules depends, besides the photoelectric characteristics of the solar panel, on the solar radiation reaching the collector area  $A_{pv}$ . Using horizontal direct and diffuse irradiance data, which is available for most places on the earth, and a 3D model of the street classes for shading analysis the solar energy reaching the collector  $E_{gen}$  for different orientations can be calculated using equation 11

$$E_{gen} = S_{dir}E_{dir} + S_{dif}E_{dif} + S_{refl}E_{refl} \quad (11)$$

The direct radiation on a tilted surface  $E_{dir}$  with the tilt angle  $\gamma_E$  and the azimuth angle  $\alpha_E$  is calculated with Eq. 12 from Duffie and William (1974)<sup>44</sup>.

$$E_{dir} = E_{dir,hor} \frac{\cos \theta_{gen}}{\sin \gamma_S} \quad (12)$$

In which the solar incidence angle  $\theta_{gen}$  is calculated as function of the collector orientation and the sun position (Quasching 1996)<sup>45</sup>. The sun height  $\gamma_s$  and solar azimuth angle  $\alpha_E$  are based on the calculation procedure by NREL (2008)<sup>46</sup>.

The diffuse radiation  $E_{dif}$  is calculated with the Perez et al diffuse irradiance model (1987)<sup>49</sup>. This model assumes a sky dome consisting of a circumsolar and a horizon zone, which overlie an isotropic background. The corresponding model coefficients for the circumsolar and horizontal brightening coefficient where taken from Perez et al. (1990)<sup>50</sup> which are asymptotic stable.

The ground reflected radiation reaching the solar panel  $E_{refl}$  was calculated as a function of the Albedo factor using the Perez and Ronald conversion model (1986)<sup>51</sup>.

To account for the losses due to shading of the solar models for each street class a 3D model (Figure 36 - 3D Model of street class L4 with the sun position (red) on the 21.06. at 13h30 CET.) was created using the software PVSyst. They layout of the different street class models was chosen to be similar to the categories used for the urban wind prediction model by Beller (2011)<sup>47</sup>. With PVSyst location specific simulations were used to create shading tables for different module orientations, tilts and heights. Besides the shading tables for the direct radiation  $S_{dir}$ , shading factors for the diffuse  $S_{dif}$  and reflected radiation  $S_{ref}$  were determined. As the sun position was calculated for each time step, the shading factor at the according sun position is looked up in the table. Values lying between the simulated ones are retrieved by linear interpolation.

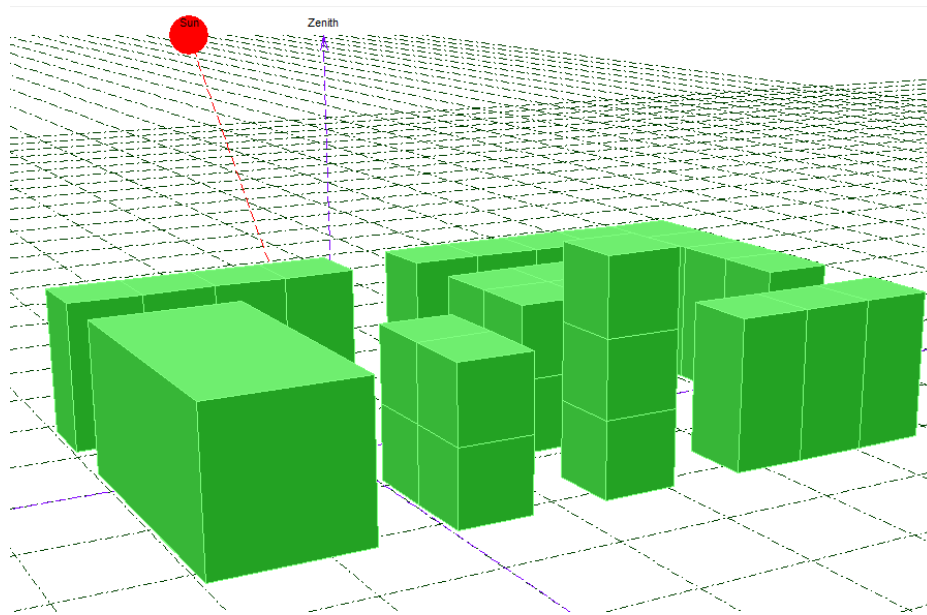

Figure 36 - 3D Model of street class L4 with the sun position (red) on the 21.06. at 13h30 CET.

The solar radiation on the collector area is used to calculate the total electrical energy delivered by the solar module to the system as a function of the solar cell efficiency and the transmittance of the tempered solar glass. This result is corrected for temperature dependency, low irradiance, reflection, spectral mismatch and dirt on the module.

By possible setting of the input variables of the PV in the mathematical model is given in the table below.

Photovoltaic cell efficiency	20 %
Photovoltaic area	1.5 m <sup>2</sup>

Photovoltaic height	6 m
Photovoltaic tilt	45 deg
Photovoltaic azimuth	0 deg

Table 10 – Input variables of the solar module

## 10.6. MODELING THE BATTERY

The battery capacity assumed in the present computations was unrealistically large – 8 kWh – in order for the battery not to discharge completely in winter, to show how changing the turbine type influences the energy balance of the system.

## 10.7. RESULTS

### 10.7.1. MODELING THE URBAN WIND CLIMATE

The analysis of the wind climate showed that the wind energy in the considered urban environments was low relative to sites in the free field. Here, results concerning one of the new districts in Copenhagen, comprising 1-2 story single family buildings with gable roofs (E2) are presented. The time series of the wind speed used in the simulations is presented in Figure 37 together with the 30-day-window running mean.

The reference height at which the wind speed was calculated was 8 m. This was assumed to be the turbine height for all the luminaries simulation of which is presented in this section. The maximum 10 min average in the time series was above 5 m/s. The mean wind speed was 1.3 m/s. Note that the displacement height in the present case was 4.25 m. On average, it is equal to two thirds of the average obstacle height in the area. The roughness length was 1.3. The sum of these two numbers was 5.55 m which was assumed to be the bottom of the logarithmic wind profile. This does not mean that the actual average wind speed below 5.55 m is zero. However, the wind speed below 5.55 m was assumed to be relatively low and difficult to approximate with the available tools. It was relatively close to the hub height assumed in the simulations which explains why the average wind speed seen in Figure 37 is relatively small. The 30-day-window running mean, in which the month-to-month wind speed variation is visible, shows that July is the month characterized by the lowest average wind speed.

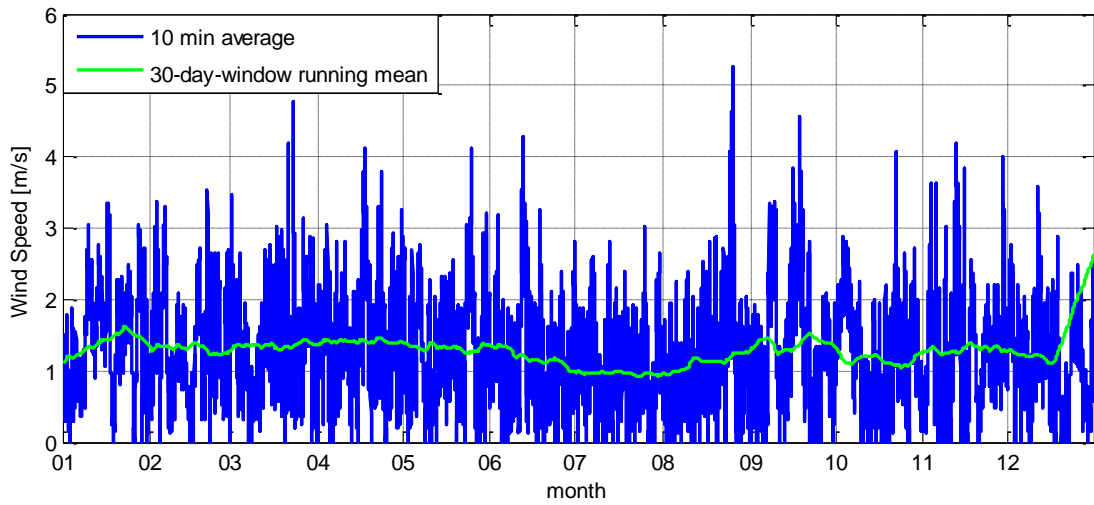

Figure 37: Time series of the 10-min-average wind speed used in the simulations together with the 30-day-window running mean; 8 m reference height

A one-week-long extract from the time series is presented in Figure 38. It shows relatively high variation in the wind speed within a week, i.e. from zero to almost 3.5 m/s which is significant given the range of values visible in the whole year.

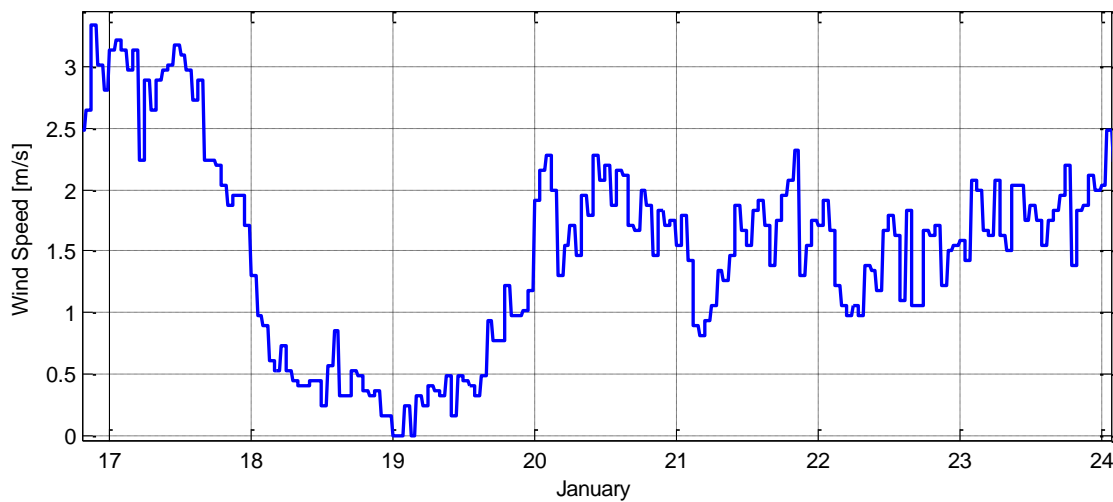

Figure 38: One-week extract from the time series of the 10-min-average wind speed used in the simulations; 8 m reference height

### 10.7.2. MODELING THE LUMINARY

Work of the luminaries of characteristics described above throughout one year in the wind climate presented in the preceding section was simulated. Figure 39 presents time series of the energy level in the batteries. If any of the



curves touched the zero level, the simulated luminary would suffer from energy deficit and stopped working. Here, the battery capacity was actually adjusted in order for none of the three curves to touch the zero level.

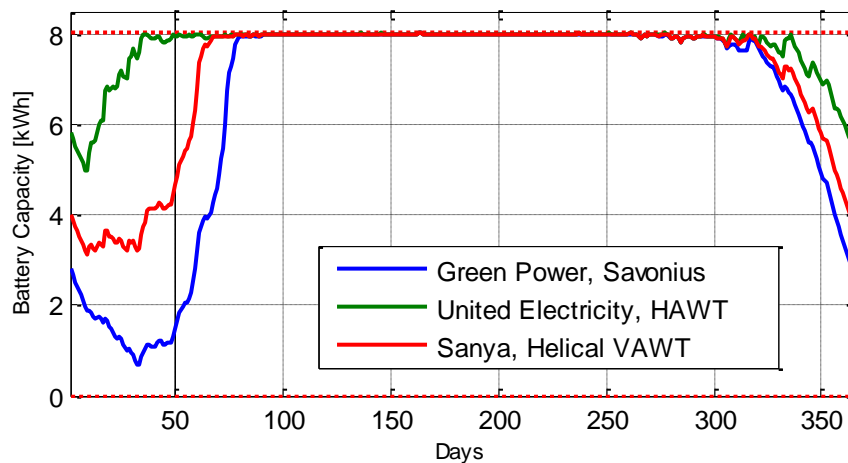

Figure 39: Time series of the energy level in the batteries in the simulated luminaries

Note that the result of the simulation was in good agreement with the presented power curves as the turbine with the most promising power curve (*United Electricity*) maintained the highest battery level throughout the year and vice versa. The simulation was iterated until the start and end energy levels of every luminary were equal. Otherwise, if a simulation started with the full battery and ended with a partly discharged battery, it would not be representative of what would happen in real life, year after year. The simulations also showed that, depending on the efficiency of the photovoltaic panels and the turbine, and the battery capacity, a luminary working in the considered environment could suffer from energy deficit in January, February or December. This is understandable as particularly long nights and short days on one hand increase the energy demand and on the other, decrease the gain.

Figure 40 presents the balance between the energy production by the turbine and the photovoltaic panel of the *United Electricity* turbine, and the consumption by the LED, regardless of the battery capacity. The figure indicates that, in general, energy production by the photovoltaic panel is much larger than by the turbine. In the summer time, the turbine would practically be unnecessary. The situation is different in winter, when the luminary may run into the risk of energy deficit. Then, the turbine and the panel would produce approximately the same amount of energy which indicates that the turbine is actually an important component of the system.

The figure also shows what was indicated by the previous figure, i.e. that the energy demand is higher in winter than summer.

The results presented in this section, combined with the fact that the battery capacity assumed in the current simulations is actually unrealistically large, indicate that maintaining a positive energy balance in winter may be a challenge that will need to be faced in the design process of the luminary.

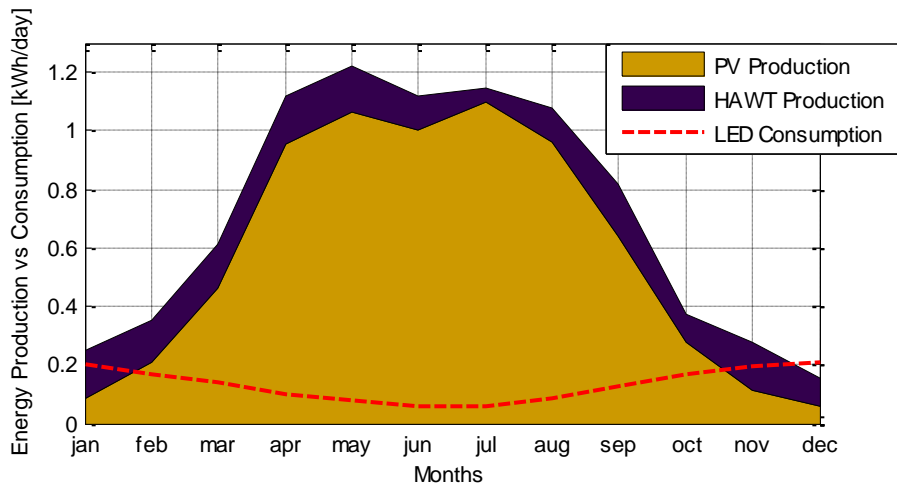

Figure 40: Balance between energy production by the turbine and the photovoltaic panel, and the consumption by the LED; *United Electricity HAWT*

## 11. DATA ANALYSIS OF COMMERCIAL SYSTEMS

### 11.1. SYSTEM ANALYSIS

The Nheolis system and the United Electricity has been operating and logging data since November 5. 2012 and November 16. 2012 respectively, and the Green power mast we haven't succeeded yet to make it operate with data logging.

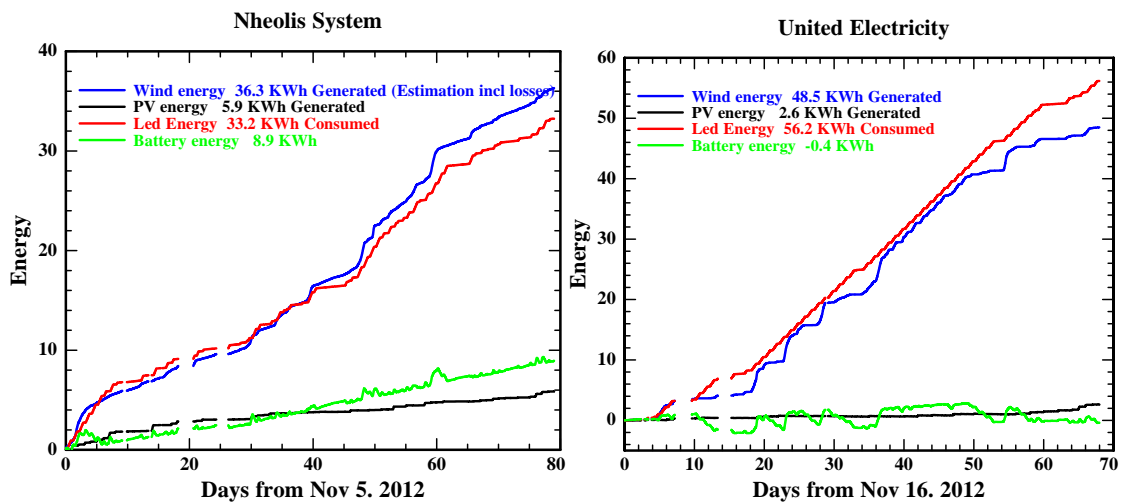
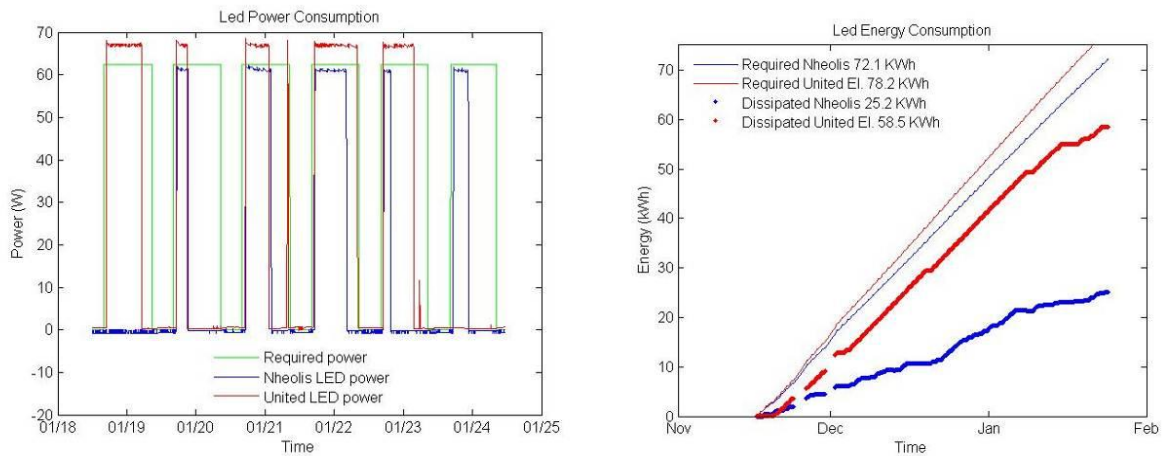

Figure 41 - Energy balance as function of time for the two measured systems.

The Energy balances for the two measured systems are shown in Figure 41 - Energy balance as function of time for the two measured systems.. The Energy to the LED is consumed energy, but for clarification the sign is reversed. For the Nheolis system it was not possible to measure the wind power and therefor it is calculated as the difference between the battery and the sum of the power from the PV and to the LED, and therefore the unknown electronic losses is included in the wind energy. As can also be seen there are periods without logging, and in this period it is neither possible measure or estimate the energy balances, and therefore it the energy sums cannot be expected to balance. As one might expect the wind is the primary source of energy for the winter period of time.



**Figure 42 - LED consumption patterns for the masts.**

In Figure 42 to the left the power consumption and the expected power consumption are plotted as a function of time, for a selected representative period of time. It is seen that when the battery is not having enough energy the LED switches of.

The systems do not use any kind of energy stretching means, e.g. dimming strategies for saving power, and neither do they save energy for morning illuminations or similar intelligent energy management.

In the right graph of Figure 42, the energy that the LEDs have spend and the energy required for the LEDs to been on through the dark period of day is plotted as a function of time starting from November 16. 2012.

It can be seen that for both systems there is not enough energy available. The Nheolis have used in totalt 24.8 kWh and needed 71.2, which means that on average the lamp have be on 35 % of the intended time.

For the United electricity system the retro fitted lamp have used in total 58.4 kWh and it needed 77.1 kWh, corresponding to that the lamp have been on 73 % of the intended time. So even though the hybrid systems is placed on an open field for measuring none of them are self sufficient. And the systems will be even worse of if placed in an urban environment.

## 11.2. PV PERFORMANCE

We have not had sufficient sun to be able to measure the solar panels at standard conditions to validate if the panels comply with what the manufacture have specified. In Figure 43 the expected energy calculated from measured horizontal insolation and the measured energy from the solar panels is plotted. It is seen that the Nheolis system is reaching approximately 2/3 of its potential and the United Electricity system is reaching approximately half its potential.

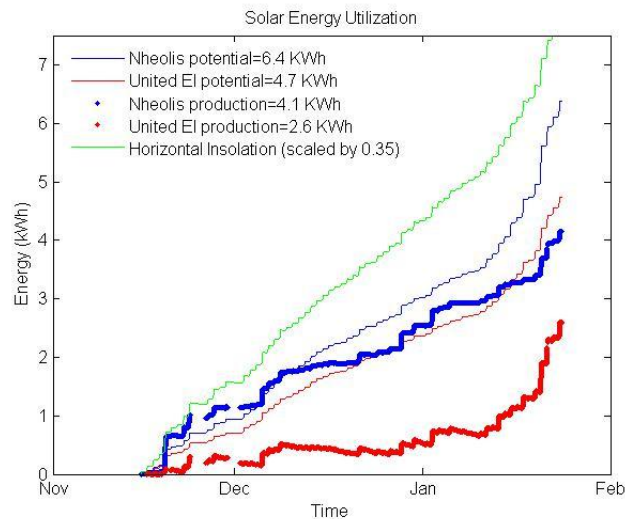

Figure 43 - Solar energy and Insolation.

The calculations of the expected energy from the panel is not exact but is probably accurate within 15-25 %, however the measured energy is still significantly below what can be expected. The big discrepancy between the measured and the expected energy indicates that the solar panels are loaded in a static way, where the load is not adjusted to the temperature and the insolation. Adding intelligent maximum power point tracking in the control, will make it much more likely to reach the expected energy of the panels. If the slopes of the graphs are compared, it seems that the Nheolis mast is optimized for lower values of solar radiation, and the United Electricity mast needs a lot of solar radiation to actually provide energy. The negative slope on the United Electricity mast can be either due to measurement uncertainties or the fact that the control dissipates power in the panel.

### 11.3. WIND PERFORMANCE

Wind turbine power time series measured at the four hybrid systems installed at DTU Risø Campus was used together with a reference wind speed time series to compute power curves representative to the four turbines. The reference wind speed was measured with a sonic anemometer installed at a metmast erected 10-20 m from the turbines. The difference between hub heights and the height at which the anemometer was installed was corrected for assuming logarithmic wind speed profile. Dimensional and dimensionless power curves for two out of four turbines – *United Electricity* and *Nheolis* – are shown below together with the corresponding power curves supplied by the manufactures.

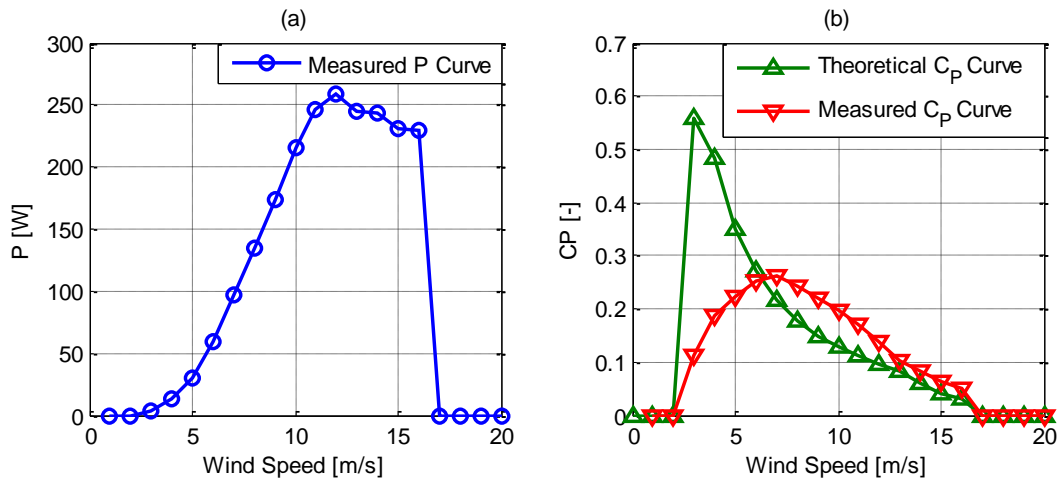

Figure 44: Measured dimensional (a) and dimensionless (b) power curves regarding the horizontal axis *United Electricity* wind turbine

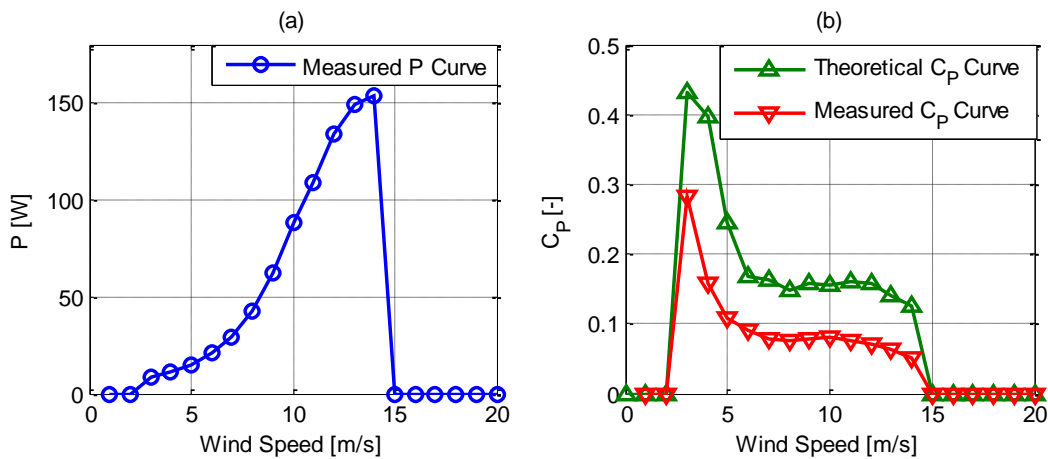

Figure 45: Measured dimensional (a) and dimensionless (b) power curves regarding the vertical axis *Nheolis* wind turbine

The measured dimensionless power curve of *Nheolis* (Figure 44 b) was of lower value than the producer-supplied in the wind speed regime from the cut-in wind speed of 2 m/s to 7 m/s. However, the measured dimensionless power curve was of higher value than the producer-supplied for the wind speed regime from 7 m/s to the cut-out wind speed of 17 m/s. Note that this particular measurement may be burdened with an error as the turbine power in this particular case was not measured directly but obtained by computing the net power given the input from the photovoltaic panel and the consumption of the LED, including possible losses in the controller.

The power of the *United Electricity* turbine, on the other hand, was measured directly and is therefore believed to be of higher accuracy. The measured dimensionless power curve (Figure 45 b) was of lower value than the producer-supplied in the whole operational wind speed regime from the cut-in wind speed of 2 m/s to the cut-out wind speed of 15 m/s.

These results indicate that time-marching simulations of the hybrid systems based on producer-supplied power curves may over predict performance of these devices, especially in winter when the overall performance is dependent on the turbine to a relatively large extent.

### 11.4. LAMP CHARACTERIZATION

The lamps of the 4 hybrid systems was characterized by an optical setup with a spectrometer (Ocean Optics WE65000 cooled to -10°C) coupled to an integrating sphere of 1 m in diameter. A part of the forward flux was measured through a gate hole in the sphere and the spectral distribution of the light could be measured this way. The total lumen output from the luminaire could not be measured by this setup. The energy consumption in W of the lamp was measured during the photometric test and the values are given below:

Lamp	Energy consumption	Color Rendering	Correlated Color Temperature (CCT)	Duv
NHeolis	60 W	73.0	7202	0.0073 (false)
China Green Energy	61.5 W	74.4	6663	0.0010 (true)
United Electricity	30 W	83.2	4693	0.0041 (true)
Urban Green Energy	62.5 W	72.4	5950	0,0055 (false)

Table 11 – Energy consumption on photometric measurements on hybrid systems

The correlated color temperature is very high for all the systems and even false in 2 cases being far from the Planckian locus and not being considered white in e.g. the ANSI SSL chromaticity standard. The color rendering is also poor and 80 is preferred. It is obvious the producers go for high efficiency, which is achieved, by high color temperature. It can also be a cultural phenomenon where people living far from equator seems to prefer warm white light and the opposite is true for people living close to equator. Whatever the explanation - the municipalities is not expected to accept CCT's above 4500 K and 3000 K is preferred. The measured spectral distribution for the lamps are shown below in Figure 46

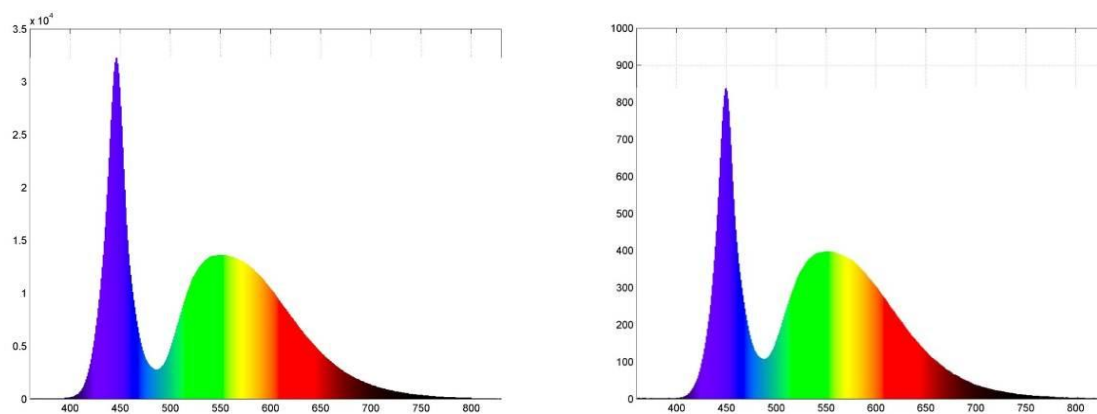

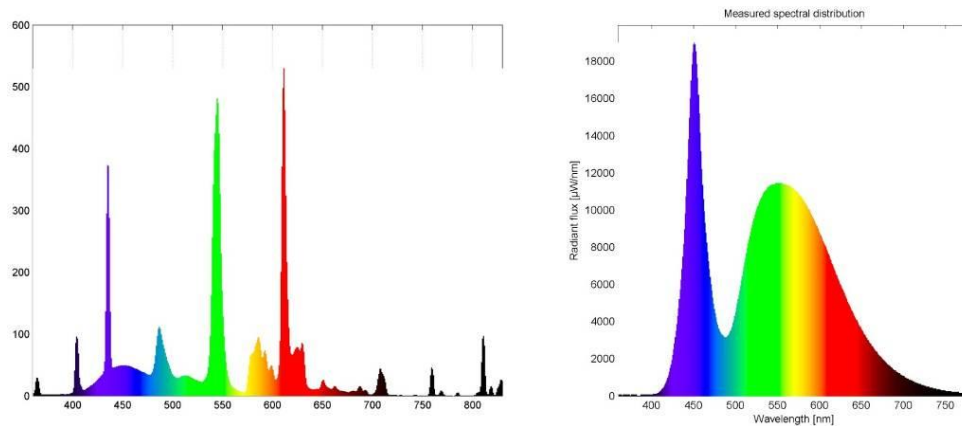

**Figure 46 - The spectral distribution of the luminaires of the hybrid street lamps. The upper left is the NHeolis, the upper right China Green Energy, the lower left United Electricity and the lower right Urban Green energy.**

The lower left curve from the luminaire on the product from United Electricity is an induction lamp.

### 11.5. TEST CONCLUSIONS

The analysis above shows that both systems does not generate enough energy for dissipating power in the lamp through the dark period of time in the winter. The systems shows different behaviours but for both systems the wind energy is contribution with the most energy.

For the solar part neither of the systems seems to be controlled in an appropriate manner, however even if the control was improved so the solar got its full potential, more energy in the system is needed, or less energy needs to be consumed. It will be fairly easy to add more and higher quality solar panels on the systems.

Furthermore all the solar panels on the 4 systems was placed from the manufacturers in a tilt angle much closer to optimal for all year production than to an optimized winter condition which is the worst case conditions in Denmark. Angling the panels closer to 90° will help towards better performance in the winter, where the sun reaches its highest point of 12° at noon on the shortest day.

The wind turbine performances is fairly overestimated from the manufacturers data compared to the measured for the two systems shown. Especially the United Electricity seems to have a dramatically lower performance at lower wind speeds than the supplied curves from the manufacturers. Lower cut in speed is necessary to work optimally at the 1.3 m/s the average calculated wind speed is shown to be at the addressed working areas for the systems. A wind turbine and generator setup optimized for exactly these wind conditions seems to be crucial for success of hybrid systems in the urban environments.



## 12. MAPPING OF HYBRID SYSTEM POTENTIAL AS FUNCTION OF STREET LIGHTING CLASS

### 12.1. POTENTIAL FOR THE HYBRID LIGHTING SYSTEM AT DIFFERENT STREET LIGHTING CLASSES

This section presents an overview of the potential for operation of the designed hybrid lighting system at different street lighting classes in Copenhagen, based on the simulated values. Here, we distinguished four street classes, descriptions of which are presented in Figure 47. The four bars in Figure 47 are colored the same way as the corresponding areas and streets in the map of Copenhagen presented in Figure 48. The reason for this is to give the reader a better understanding of what different street classes are. The values represented by these bars show the ratios of the cumulative yearly energy gain from the PV and turbine to the yearly energy consumption of the LED. The higher the value, the better conditions for operation of the hybrid system. However, note that a value higher than one does not ensure that the system would not suffer from energy deficit in winter. This is because the system would likely not be grid connected, and after the battery has charged, the excess produced energy would be lost.

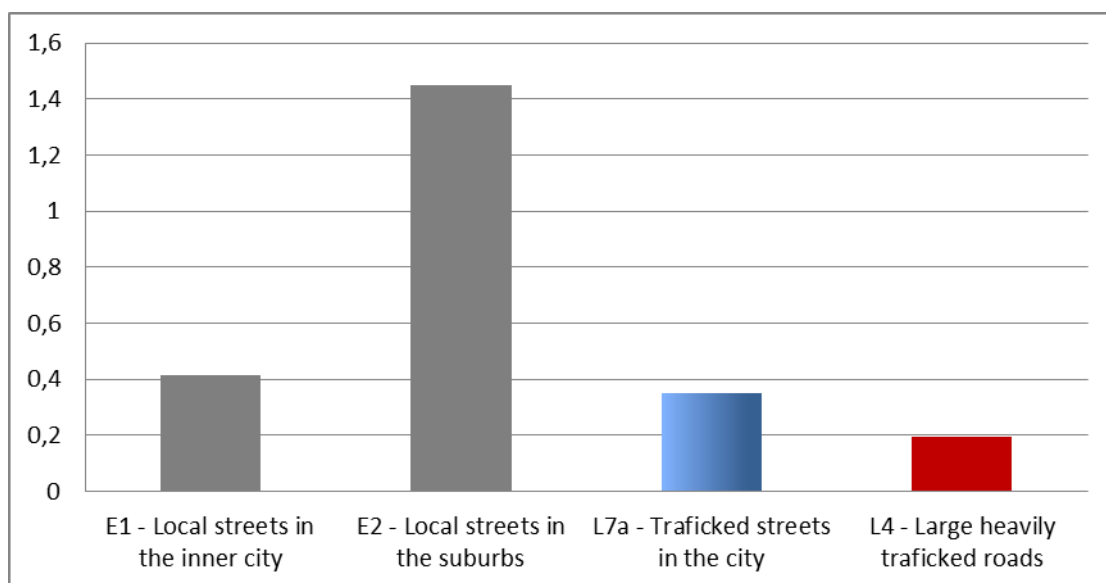

Figure 47: Ratio of the cumulative yearly energy gain from the PV and turbine to the yearly energy consumption of the LED; simulated values concerning four different street classes in Copenhagen

It seems from the figure that local streets in the suburban areas are the best place for the hybrid systems to operate while the other three classes show less favorable conditions. This is primarily due to large differences in the energy demand of the LED luminaire in those different surroundings. Secondly, it is because of differences in energy gain from the PV panels due to different shading losses. The shadings have a great impact on the solar yields and vary greatly between street classes, as well as location specific topologies. Using the energy model, shading losses for actual locations can be calculated. The least difference was made by the differences in wind potential as the turbine would overall produce significantly less energy than the PV panels. However, Figure 47 should be treated as indication

of possible future design challenges rather than a quantitative assessment of where to install the present-design luminary. The reason for this is that for trafficked city streets (L7a and L4) the hybrid system could be dimensioned different than for local streets (E1 and E2) as it is currently. Potentially, the turbine could be positioned higher, and both the turbine and the surface area covered with PV panels could be larger. These changes could significantly increase the energy gain. However, detailed investigation of such possibilities is to be carried out in future work.

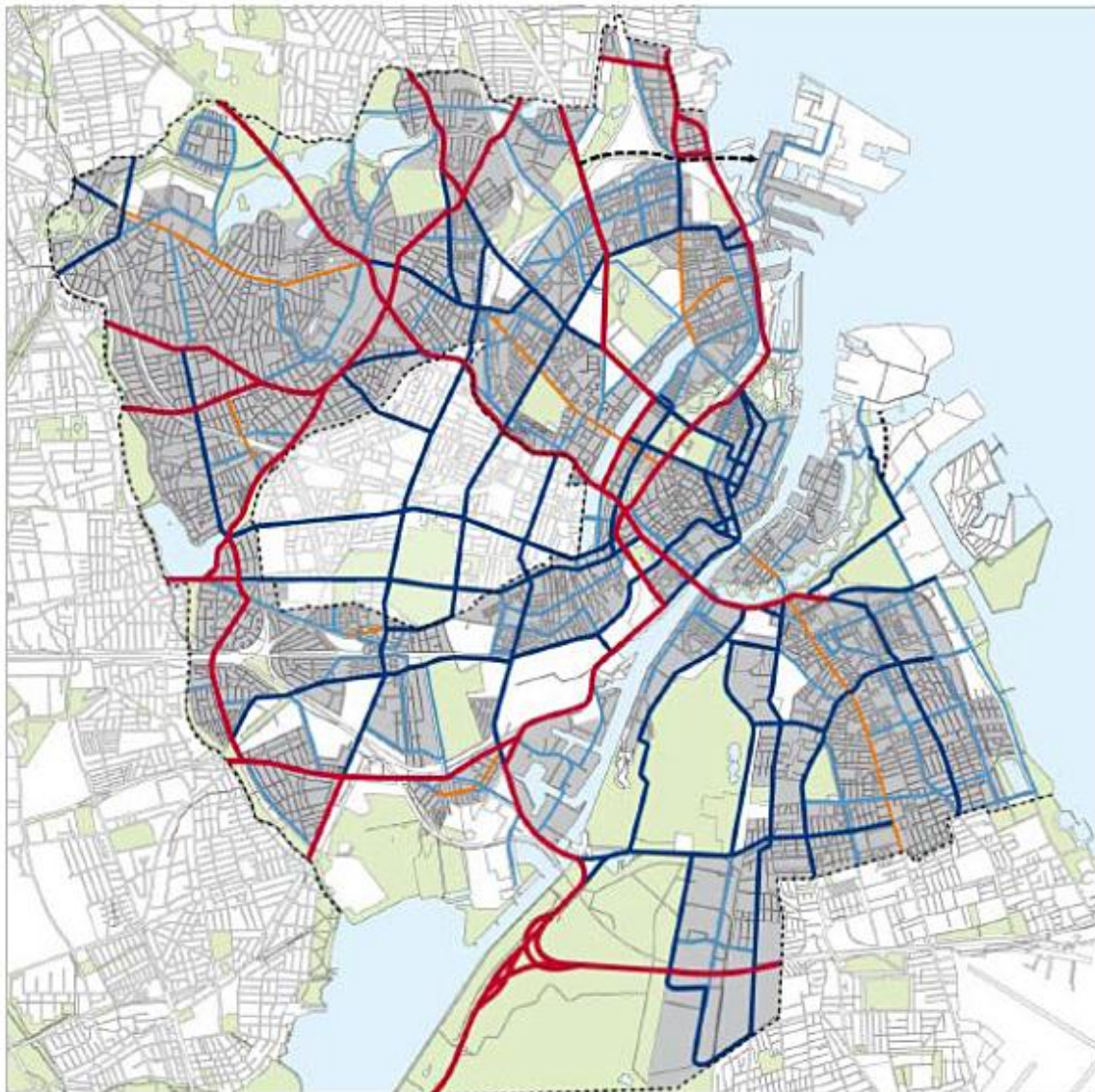

Figure 48: Street hierarchy in Copenhagen; Maare<sup>52</sup>

## 13. DESIGN AND DIMENSIONING OF CO2 NEUTRAL LUMINAIRE

Due to the relative low lux (2.5) requirements for the E2 street class lamps and the large amount of those – and the fact that these streets are with mostly low buildings it was chosen to dimension a hybrid system for these streets in Copenhagen. Among with the arguments mentioned above, it seems to be the best street class in Copenhagen to make a stand-alone hybrid street lighting luminaire for. The system design below is just one way of designing it.

### 13.1. LIGHTING

Typical light fixture point height in Copenhagen on E1/E2 roads is 5-6 meters with 30 meters between masts. To avoid disturbing glare, the rule of thumb is that a mast should not illuminate anything further away than 3 times the mast height. In the end visual assessment is used to evaluate the resulting glare.

The instantaneous power consumption of a street lighting fixture is mainly calculated from the following parameters: The efficiency of the light source, the fraction of light directed at the road, the regulatory requirement for lighting levels on the road and the size of the area to be illuminated. The compound energy consumption over time is further affected by the length of on/off cycles and any possible dimming scheme. The calculations below are based on the following scenarios:

- E2: Local roads, suburbs - Minimum illuminance: 2.5 Lux
- Dimming: The lighting requirement is lowered by 50% between 23.00 and 06.00.
- On/off times: The on/off times used here are estimates based on sunrise and sunset. Actual on/off times are forthcoming from Copenhagen Municipality.
- Distance between lighting fixtures: 30 meter
- Road width: 13 meter

LEDgine from the partner, Philips Lighting Denmark, in the project has the following features

- Efficiency of the LED module: 99 lm/W (Philips LEDGINE)
- Utility factor (fraction of generated light reaching the road): 50% (Rough estimate from the performance of normal LED optics.)

The maximum power consumption is 0.35 kW/day (in December) for illuminating an area of 30 m x 13 m, where 80% of the produced light falls on the designated area. Using a fixture LED with an efficiency of 85 lumen/Watt. (3000 K)

A LEDgine light source from Philips is provided in the project, a unit with 32 LEDs and asymmetric lenses, size ca. 20 cm x 10 cm or two units with 16 LEDs, size ca. 20 cm x 5 cm.



Figure 49 – LEDgine module from Philips

The necessary driver electronics from Philips with the dimensions 25 cm x 6 cm x 4 cm



Figure 50 – Programmable LED driver from Philips Lighting

We can use the highest power consumption as a worst case scenario; this is in December, where the lighting is on for the longest time. It can be seen from Figure 51 that if a system described by the characteristics above is to be feasible, the system must be able to provide the equivalent of 25 watt (E2) (or 45 watt (E1)) through all 24 hours, throughout December.

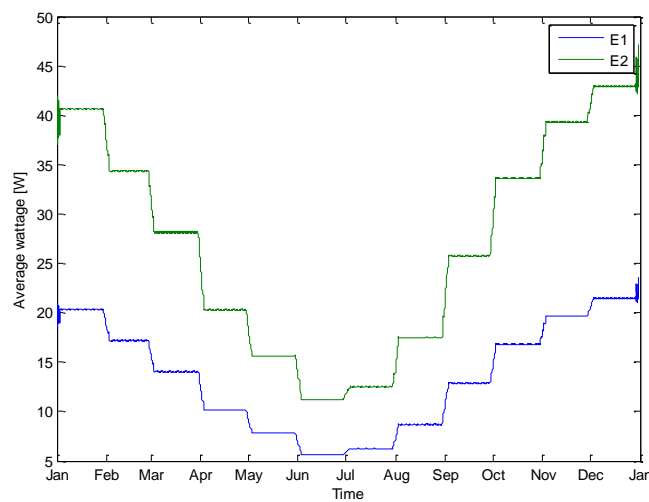

Figure 51 - The figure shows a 5 day average wattage needed to maintain the required lighting level.

## 13.2. WIND TURBINE

Among horizontal axis (HAWT), Darrieus and Savonius wind turbine types, a choice was made to pursue the design of a Savonius type wind turbine for the following reasons. A basic advantage over HAWT is that Savonius and Darrieus are insensitive to changing inflow direction and therefore better suited to urban environment. An advantage of Savonius over Darrieus wind turbine is that while Savonius is characterized by a relatively low cut-in wind speed, Darrieus lacks self-start capability. A disadvantage of Savonius turbine is, in general, low efficiency. However, the gap between the best and worst performing turbine types for such small turbines and wind speeds is small relative to megawatt-size wind turbines. This is because the efficiency of all turbine types drops together with the Reynolds number.

Savonius turbines may be divided into conventional (with paddles in the vertical direction) or helical (with the inner edges of the paddles straight in the vertical direction and the outer edges twisted around turbines' axis of rotation, typically by 90 degrees - Figure 52). The disadvantage of the conventional turbine is that at certain inflow angles, the starting torque of the turbine is negative which impedes the turbine's self-start capability. This issue may be resolved by using double- and triple-stepped rotors (each step being staggered from the others with a certain angle - Figure 53) where, according to Menet and Bourabaa<sup>57</sup>, a double-stepped rotor already ensures positive torque at every inflow angle. Further, Kamoji et al.<sup>58</sup> and Hayashi et al.<sup>54</sup> report that an increase in the number of steps corresponds to a decrease in the turbines' maximum power coefficient being the measure of the turbines' performance.

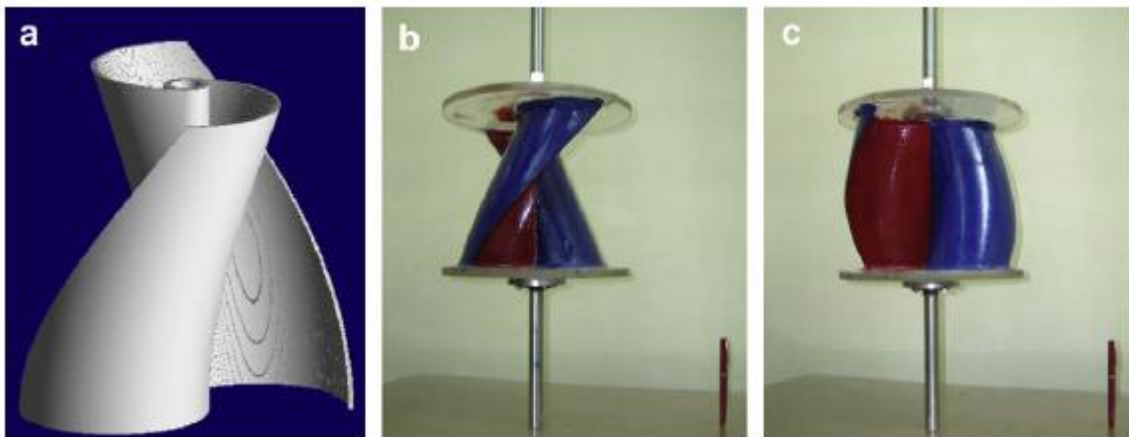

Figure 52: Helical Savonius rotors (a) with provision for shaft between the end plates; (b) and (c) two views of helical rotor without shaft between the end plates; Kamoji et al.<sup>55</sup>

Kamoji et al.<sup>55</sup> report that the problem of negative starting torque may be also resolved by using a helical Savonius turbine. Kamoji et al.<sup>55</sup> also report that the power coefficient of an optimized helical turbine may reach the power coefficient of an optimized conventional Savonius turbine. For those reasons, and due to its aesthetics, a helical Savonius turbine of 90 degree twist was chosen for the present design.

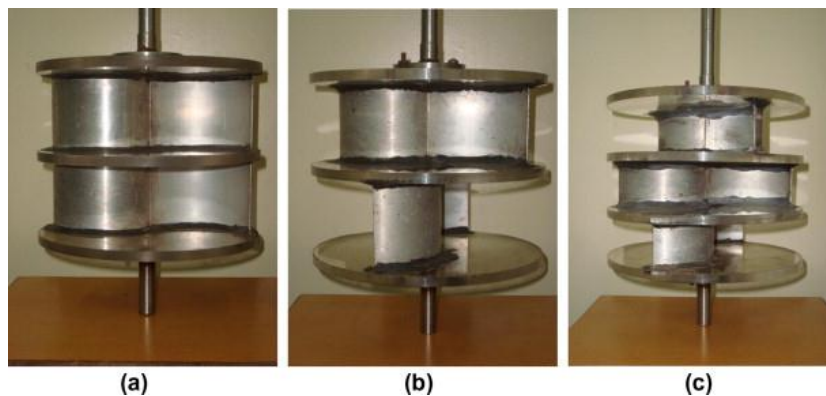

Figure 53: Single- (a), double- (b) and triple-stepped (c) Savonius rotors; Golecha et al.<sup>53</sup>

As the power output of the turbine is linearly dependent on its projected area, it is recommended to design the largest turbine within the limits dictated by the aesthetics and the overall system size. The dimensions of the designed turbine are therefore 1.8 m height by 0.5 m diameter, resulting in the projected area of 0.9 m<sup>2</sup>.

The power output also scales with wind speed cubed, while the wind profile in urban environment is elevated from the ground. This means that until a certain height the average wind speed is very low. Therefore, it is of outmost importance to place the turbine as high as possible, within the limits dictated by the regulations concerning a specific urban environment. For this reason the bottom plate of the turbine was placed at the top of the lamp, at 5.2 m height.

Menet and Bourabaa<sup>57</sup> report that so called end plates (horizontal circular plates mounted to the paddles at the top and bottom of the turbine, slightly exceeding diameter of the turbine - Figure 52(b,c)) increase the power output from conventional Savonius turbines by channeling air through the turbines. Similar research regarding helical turbines has not been found by the author. However, Kamoji et al.<sup>55</sup> who conduct extensive experimental work on helical turbines utilize such plates. Therefore, the decision was made to utilize end plates in the present design. These were, however, designed smaller than usually, due aesthetic aspects of the design.

Menet et al. as well as Kamoji et al.<sup>57,55</sup> report that presence of the vertical shaft between the end plates of the turbine decrease the turbine's performance. In the experiment by Kamoji et al.<sup>55</sup>, the maximum power coefficient obtained by the turbine with the shaft is only 56% of the maximum power coefficient of the turbine operating without the shaft. It was therefore decided to exclude the shaft from between the end plates of the present design.

A modified Savonius turbine is a turbine with the cross-sectional shape of the paddles different from the standard semi-circular. Kamoji et al.<sup>55</sup> report that such a modification may increase the performance of the conventional Savonius turbine. However, no research concerning the effect of similar modification on the performance of helical Savonius rotors has been found by the author. Taking into account this and the fact that standard semi-circular paddles may be easier to manufacture, a decision was made to utilize standard semi-circular paddles in the present design.

The next parameter to consider is the number of paddles. A literature review indicated that the most popular variation of the Savonius turbine is the one with two paddles. Therefore, two paddles were used in the present design.

Another important parameter to consider is so called overlap marked in Figure 54 as 'e'. It is typically non-dimensionalized with the paddle diameter, 'd', and expressed as the overlap ratio, e/d. Menet et al.<sup>57</sup> report that the

optimal value for a conventional Savonius rotor is  $e/d=0.42$ . However, Kamoji et al.<sup>5</sup> report that in the case of helical turbines, the lack of overlap ratio results in the highest power coefficient and therefore the best performance. For this reason, the whole rotor – both paddles – was designed from a single S-shaped sheet of material.

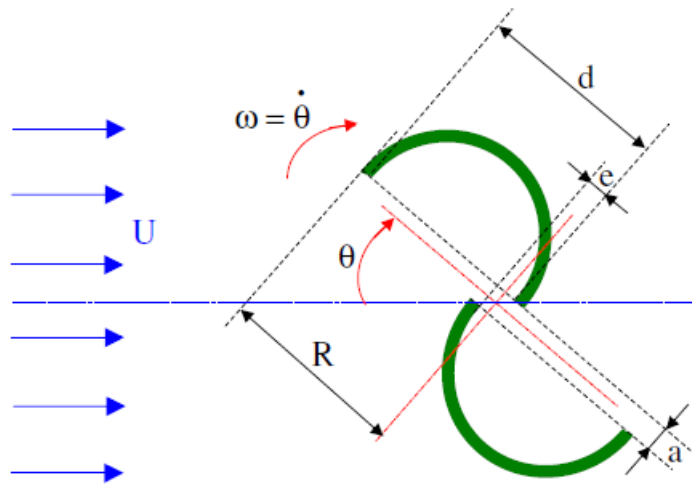

Figure 54: Scheme of a Savonius rotor; Menet et al.<sup>57</sup>

The turbine designed in accordance with the requirements listed above is presented in Figure 55. More renderings of the luminary and the turbine are presented further in this report.



Figure 55: Present design 90-degree twist Savonius turbine with small end plates at the top and bottom of the turbine, visualized with the LED luminary underneath the turbine

### 13.3. SOLAR PANELS

By possible setting of the input variables in the mathematical model described earlier in the report the parameters for the solar module can be found and is given in the table below.

Photovoltaic cell efficiency	20 %
Photovoltaic area	1.5 m <sup>2</sup>
Photovoltaic height	6 m
Photovoltaic tilt	90 deg
Photovoltaic azimuth	0 deg

Table 12 – Input variables of the solar module

### 13.4. 8.3 MOCK UP

Based on the technological limits agreed on above a design process was carried out in close corporation between Faktor 3 and Henning Larsens Architects in iterational steps with modelling and consultancy with the technical part of the group. The project group agreed on the following design (Figure 56) seems to have proper dimensions a least based on simulations to work stand-alone on a E2 road



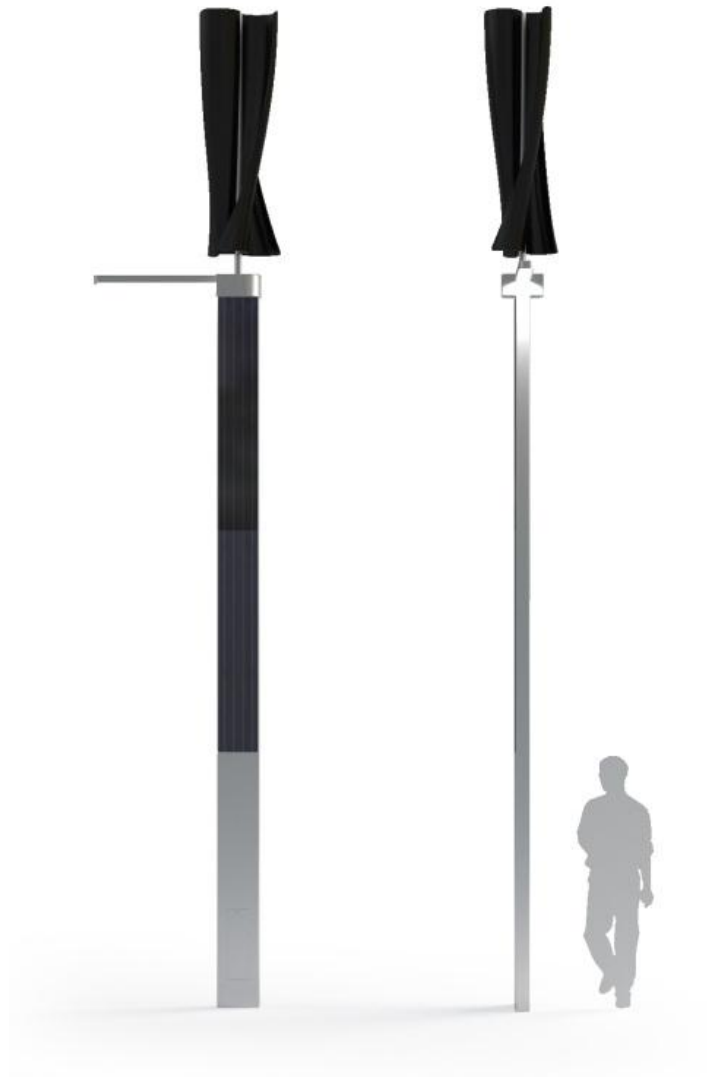

Figure 56 – Design by Faktor 3 and Henning Larsens Architects of a hybrid system for E2 street classes in Denmark

A Mock up being 7.5 meters high was made to show the system in 1:1 size.

### 13.5. LAB MODEL

To work with the energy system inside the lamp a lab model of the system was created (Figure 57)



**Figure 57 – Lab model of the energy system for the designed hybrid street lighting system**

From left on the figure a black battery is seen connected to the electrical controller box in front of the battery. The box gets input energy from the generator where the developed wind turbine is mounted on top of. The LED panel in the right size for the illumination task is shown to the right (the white plate). A solar panel (not shown on the picture) in  $1,5 \text{ m}^2$  can be connected to the electrical controller box also. The lab system can therefore be tested under different conditions and is an important tool in the next phase of the project where optimization comes in play. Here the lab model is a cornerstone to test both parts of the system and the system as whole with different parameters and even changing parts with optimized parts to benchmark against the former best.

## 14. CONCLUSIONS

Hybrid systems for lighting is definitely going to have a place in the future urban environment and in the modern energy system of the future. The very high cost of cable digging reaching above 5000 DKK pr. meter in Copenhagen city center and being 1000 DKK pr. meter in general makes it attractive to save this cost. Furthermore the energy prices are going just one way – up. And since these systems "saves" energy that should be bought inclusive high taxes the savings is about 2 DKK pr. kWh. The future seems to work positively for the hybrid systems since the LEDs are still doubling its efficiency in lm/W each 3<sup>rd</sup> year for some time ahead and therefore the energy system size can be reduced on the pole making it more and more cost effective as the other technologies are developing. Also battery technology are having a positive development towards more energy compact and long lasting systems with many cycles so battery change can be cut down to maybe every 10 years.

The project group tested 4 international state-of-the-art hybrid street lighting systems. It is evident that this technology is not very mature both on the state of the technology and as a market. The project group acted on behalf of Copenhagen Municipality in the inquiry phase and there was surprisingly many missing parts to the delivered hybrid system. Only one system was delivered and was working out of the box. One of the systems was missing close to half of the promised components. The assembly guides was of very low quality of all the products and most documentation was in Chinese. The manufacturers seems to be mostly makers of small wind turbines and are creating additional sales by building it into a lighting system. The information about the systems in form of data was very poor and inadequate. It is interesting to see companies selling lighting systems supplying almost none data for the luminaire. This will be a barrier against the opportunity to sell the systems at least in Denmark where thorough data for the lighting systems is needed by the municipalities og service organization handling the lighting here if the lighting should be evaluated against the regulations.

The 4 tested systems are not tested throughout a year but at least 3 of the systems is measured to not be self sufficient in with energy – even when placed in an open field which is expected to be best case conditions. The controller boxes of the systems seems to be more or less lacking electronics for maximizing energy harvesting from the solar panels. The wind turbine for all the systems seems to be performing lower and even much lower in one case than the supplied power curves from the manufacturer. Lower cut in speed is necessary to work optimally at the 1.3 m/s the average calculated wind speed is shown to be at the addressed working areas for the systems. A wind turbine and generator setup optimized for exactly these wind conditions seems to be crucial for success of hybrid systems in the urban environments. This is an important research area that can make a big difference for hybrid systems.

In the project at mathematical model for simulation of the energy system in hybrid system under different urban environment setups over a normal year based on data from weather stations. This tool showed to be very relevant in both the evaluation process of commercial systems for use on a given site but also in the dimensioning process of new hybrid lighting systems tailored to use in a given environment. The modelling tool easily finds weak spots in the energy chain so the individual parameters such as solar panel size, orientation, wind turbine height, projected area, battery capacity can be optimized to fit the energy consumption of the lighting technology. By filling in lighting strategies to dim the light at specific clock times during the night etc. makes it possible to tweak the parameters even more to make an at least plausible energy system for an addressed use.

Design is a very subjective thing but to the project group representing the whole value chain the thing everybody agreed on was that the hybrid systems on the market did lack good design. A suggestion for a hybrid system for Denmark called "CopenHybrid" was created based on full filling the lighting requirements for E2 street class roads on a yearly basis. By use of the mathematical model and a simulation of a "standardized" E2 road having only 2 storey buildings it was possible to make a system that at least fitted mathematically to be self sufficient all over a Danish year

and supply enough power. It was though assumed that state of the art electronics for optimized harvesting energy from the solar panels is used and generator system can be created harvesting energy at higher efficiency and having a cut in speed below 1.5 m/s can be developed.

Hybrid street lighting systems have a bright future and the project has definitely shown that it is an energy system where the weakest link are limiting for the performance of the whole system. The weak links of the state of the art systems on the market is very far from optimal so a lot of potential is available and a good market position is open for companies being the first to reach this goal.

## 15. DISSEMINATION

The project has been disseminated at the following events and publications:

- Skrzypinski, Witold Robert ; Bak, Christian ; Beller, Christina ; Thorseth, Anders ; Bühler, Fabian ; Poulsen, Peter Behrendorff ; Andresen, Christian, Wind Turbines on CO2 Neutral Luminaries in Urban Areas, EWEA 2013 - European Wind Energy Conference & Exhibition, Vienna 2013
- Poulsen, Peter Behrendorff ; Dam-Hansen, Carsten ; Thorseth, Anders ; Thorsteinsson, Sune ; Ellermann, Stine ; Bak, Christian ; Skrzypinski, Witold Robert ; Beller, Christina ; Kock, Carsten Weber ; Bühler, Fabian ; Harboe, René Kirstein ; Boesgaard, Per ; Jensen, Tim ; Søndergaard, Ole ; Andresen, Christian ; Fahlén, Morten ; Maare, Thomas ; Prestegaard, Hugo ; Poulsen, Jan ; Kremmer, Susanne, CopenHybrid – Development of a CO2 neutral hybrid street lighting system for the Danish municipalities' illumination classes, 4th World Summit for Small Wind (WSSW 2013), Husum, 2013
- Poulsen, Peter Behrendorff ; Dam-Hansen, Carsten ; Corell, Dennis Dan ; Thorsteinsson, Sune ; Thorseth, Anders ; Petersen, Paul Michael ; Bak, Christian ; Skrzypinski, Witold Robert, CO2 neutralt armatur – CopenHybride, By Land Lys, Albertslund, 2012
- <http://www.gate21.dk/Projekter/CO2-neutralt-byumsarmatur/> (2011)
- [http://www.electronic-supply.dk/article/view/58391/dansk\\_konsortium\\_vil\\_lave\\_co2neutral\\_gadelampe](http://www.electronic-supply.dk/article/view/58391/dansk_konsortium_vil_lave_co2neutral_gadelampe) (2011)
- <http://ing.dk/artikel/ny-dansk-gadelampe-far-indbygget-vindmolle-og-solceller-115447> (2011)
- <http://www.klimaupdate.dk/default.asp?newsid=1157&opt=1> (2011)
- <http://www.danskllys.dk/newsdetail/article/lkcjxvnhkvae.html> (2011)

Information about the project was discussed at the following events

- 3rd Expert meeting SSL Annex 4E, Stockholm, Sweden 6. - 8. September 2011
- 2011 IES Street and Area Lighting Conference, New Orleans, USA 18. - 21. September 2011
- The Hong Kong International Lighting Fair 26. - 29. Oktober 2011
- Light and Building 2012, Frankfurt Messe, 15. – 20. April 2012

To be published

- CO 2 neutral armature – DTU Dynamo – the April 2013 issue
- CopenHybrid – Development of a CO2 neutral hybrid street lighting system for the Danish municipalities' illumination classes. – EUPVSEC 2013 September 2013
- TV2 Lorry April 2013

## 16. REFERENCES

1. International Energy Agency 2009, *Technology Roadmap, Wind Energy*, Paris. Available at [www.iea.org](http://www.iea.org), (Viewed 16-05-2012).
2. Philips 2009, *Sustainable Cities, A simple switch in urban lighting*, Holland. Available at [www.lighting.philips.dk](http://www.lighting.philips.dk), (Viewed 24-05-2012).
3. Maare, T 2011, *Oplæg til finansieret udskiftning af gadebelysning, teknisk beskrivelse*, Copenhagen. Appendix V.
4. Ingeniøren.dk 2012, *Solceller i vækst på 600 procent*. Available at <http://ing.dk/artikel/129435-solceller-i-vaekst-paa-600-procent> (Viewed 08-07-2012).
5. Energinet 2011, PSO-tariffen. Available at <http://energinet.dk/DA/EI/Engrosmarked/Tariffer-og-priser/PSO-tariffen/Sider/default.aspx> (Viewed 25-06-2012).
6. Kitzing, L 2011, *Feasibility in Practice, Session 1*, PowerPoint slides, Course Material 45004 Feasibility Studies and Assessment of Energy Systems E11.
7. Jacobs, A 2004, *SynthLight Handbook*, Low Energy Architecture Research Unit, London Metropolitan University. Course Material 11120 Daylight in Buildings E11.
8. Schubert, EF 2006, *Light-Emitting Diodes*, Cambridge University Press, United Kingdom. Pages 284-285, 322.
9. Nelson, J 2003, *The Physics of Solar Cells*, Imperial College Press, London. Chapters 1 and 8.
10. Kardynal, B 2011, *2<sup>nd</sup> lecture*, slides, DTU, Lyngby. Course Material 34540 Lysemmitterende dioder og solceller til energianvendelser E11.
11. Philips 2011, *Case study, LED-vejbelysning*. Available at [www.lighting.philips.dk](http://www.lighting.philips.dk), (Viewed 12-06-2012).
12. Energistyrelsen, Energinet 2012, *Technology data for energy plants*. Available at <http://www.ens.dk/DA-DK/INFO/TALOGKORT/FREMSKRIVNINGER/TEKNOLOGIKATALOG/Sider/Forside.aspx> (Viewed 31-05-2012).
13. Beller, C 2011, *Urban Wind Energy*, PhD thesis, Risø DTU, Roskilde.
14. Svendsen, S 2011, *Electrical Lighting and Daylighting*, PowerPoint slides, DTU, Lyngby. Course Material 11120 Daylight in Buildings E11.
15. Munch, K 2010, 'Nye Krav til Lyskilders Energieffektivitet', *LYS*, 1-2010. Available at <http://www.centerforlys.dk/ekstra.php?id=78>, (Viewed 30-05-2012).
16. Petersen, P M 2011, *Light emitting devices*, slides, DTU, Lyngby. Course Material 34540 Lysemmitterende dioder og solceller til energianvendelser E11.
17. Wikipedia 2012, Color rendering index. Available at [http://en.wikipedia.org/wiki/Color\\_rendering\\_index](http://en.wikipedia.org/wiki/Color_rendering_index) (Viewed 04-07-2012).
18. Københavns Kommune 2007, *Natten I Byens Lys, Retningslinier*, København. Available at [www.kk.dk/byenslys](http://www.kk.dk/byenslys), (Viewed 25-05-2012).
19. Focus Lighting 2012, Nyx 330 Lygtehoved, Downloads. Available at <http://focus-lighting.dk/showproduct.php?productId=26#downloads> (Viewed 17-06-2012).
20. Zhaga 2012, *Zhaga, Making LED light sources interchangeable*. Available at <http://www.zhagastandard.org/> (Viewed 09-07-2012).
21. Philips 2010, *LEDs til levende byer*, Holland. Available at [www.lighting.philips.dk](http://www.lighting.philips.dk), (Viewed 25-05-2012).
22. Olivarius, P 2012, *LED i udendørsarmaturer*, PowerPoint slides, From LED Conference 2012.
23. Fontoynt, M 2011, *A critical review of light sources, luminaires and light schemes*, PowerPoint slides, DTU, Lyngby. Course Material 34540 Lysemmitterende dioder og solceller til energianvendelser E11.
24. U.S. Department of Energy 2011, *Solid-State Lighting Research and Development: Manufacturing Roadmap*, Washington.

25. International Energy Agency 2010, *Technology Roadmap, Solar photovoltaic energy*, Paris. Available at [www.iea.org](http://www.iea.org), (Viewed 16-05-2012).
26. Beller, C 2009, *Urban Wind Energy – State of the Art 2009*, Risø-R-1668(EN), Roskilde.
27. World Wind Energy Association 2012, *Small Wind World Report 2012*, China.
28. Wikipedia 2012, Lift (force). Available at [http://en.wikipedia.org/wiki/Lift\\_\(force\)](http://en.wikipedia.org/wiki/Lift_(force)) (Viewed 09-07-2012).
29. Bossche, PV, Vergels, F, Mierlo, J, Mahes, J, Autenboer, W 2006, *SUBAT: An assessment of sustainable battery technology*, Science Direct, Elsevier.
30. Vejdirektoratet 1999, *Vejregler for vejbelysning*, København. Available at <http://vejregler.lovportaler.dk/> (Viewed 08-02-2012).
31. Gate 21 2012, *Om Gate 21*. Available at <http://www.gate21.dk/> (Viewed 08-06-2012).
32. Maare, T 2010, *Belysningsprojektkrav i Københavns Kommune*, Københavns Kommune, Teknik og Miljøforvaltningen, Copenhagen. Appendix X.
33. Philips 2011, *Case study, Motorvejsbelysning*. Available at [www.lighting.philips.dk](http://www.lighting.philips.dk), (Viewed 12-06-2012).
34. Vejdirektoratet 1999, *Vejbelysning, Håndbog for tekniske forhold*, København. Available at <http://vejregler.lovportaler.dk/> (Viewed 08-02-2012).
35. Commission Internationale de l'Éclairage 2000, *Technical Report, Road Lighting Calculations*, CIE 140 – 2000, Vienna. (til og med)
36. Troen I, Petersen EL: *European Wind Atlas*; ISBN 87-550-1482-8; Risø National Laboratory, Roskilde, Denmark; 1989
37. Beller Ch: *Urban Wind Energy*; Risø-PhD-89(EN); Risø DTU National Laboratory for Sustainable Energy; 2011
38. Badde O, Plate EJ: *Einfluss verschiedener Bebauungsmuster auf die windinduzierte Gebäudebelastung*; in: Abschlusskolloquium Strömungsmechanische Bemessungsgrundlagen für Bauwerke; University of Karlsruhe, Germany; 1994
39. Wieringa J, Davenport AG, Grimmond CSB, Oke TR: *New revision of Davenport roughness classification*; 3<sup>rd</sup> European & African Conference of Wind Engineering, Eindhoven, Germany; 2001
40. Bak, C., 2008. Sensitivity of Key Parameters in Aerodynamic Wind Turbine Rotor Design on Power and Energy Performance; *J. of Phys.: Conf. Series*, Volume 75.
41. CIE, 2010. *CIE Technical Report 191:2010*. s.l.:CIE.
42. DOE, 2010. *Energy Savings Potential of Solid-State Lighting in General Illumination Applications 2010 to 2030*, s.l.: s.n.
43. Mertens, S., 2009. 1ste Evaluatie meetresultaten testveld kleine windturbines Zeeland; Rapport 0904000.R01. *Ingreenious*.
44. Duffie, John A.; Beckman, William A.: *Solar energy thermal processes*. John Wiley & sons, New York, 1974.
45. Quasching, Volker: *Simulation der Abschattungsverluste bei solarelektrischen Systemen*. Verlag Dr. Köster, Berlin, 1996.
46. Calculation of solar elevation and azimuth based on the calculation procedure by NOAA (<http://www.srrb.noaa.gov/highlights/sunrise/azel.html>)
47. Beller, Christina: Development of a Simulation Tool to Predict Urban Wind Potential. *Sustainability in Energy and Buildings*, 2011, pp. 111–120.
48. National Renewable Energy Laboratory: *Solar Position Algorithm for Solar Radiation Applications*. NREL/TP-560-34302, 2008.
49. Perez, Richard; Seals, Robert; Ineichen, Pierre; Stewart, Ronald; Menicucci, David: A new simplified version of the Perez diffuse irradiance model for tilted surfaces. *Solar Energy* Vol.39, 1987, pp.221-231.
50. Perez, Richard; Ineichen, Pierre; Seals, Robert; Michalsky, Joseph; Stewart, Ronald: Modeling daylight availability and irradiance components from direct and global irradiance. *Solar Energy* Vol. 44, 1990, pp.271-289.
51. Perez, Richard; Stewart, Ronald: Solar irradiance conversion models. *Solar Cells* Vol.18, 1986, pp. 213-222.

52. Maare, T 2011, *Oplæg til finansieret udskiftning af gadebelysning, teknisk beskrivelse*, Copenhagen. Appendix V.
  53. Kamoji MA, Prabhu SV, Kedare SB: *Experimental investigations on single, two and three stage conventional Savonius rotor*. Int J EnergyRes 2008;. doi:10.1002/er.1399.
  54. Hayashi T, Li Y, Hara Y: *Wind tunnel tests on a different phase three-stage Savonius rotor*. JSME Int J B 2005;48:9–16.
  55. Kamoji MA, Kedare SB, Prabhu SV: *Performance tests on helical Savonius rotors*. Renewable Energy 34 (2009) 521–529
  56. Kailash G, Eldho TI, Prabhu SV: *Influence of the deflector plate on the performance of modified Savonius water turbine*. Applied Energy; Volume 88, Issue 9, September 2011, Pages 3207–3217
  57. Menet JL, Bourabaa N: *Increase In The Savonius Rotors Efficiency Via A Parametric Investigation*. Ecole Nationale Supérieure D'ingénieurs En Informatique Automatique Mécanique Énergétique Électronique De Valenciennes (Ensiame) -Université De Valenciennes - Le Mont Houy F-59313 Valenciennes Cedex 9 France
  58. Kamoji MA, Kedare SB, Prabhu SV: *Experimental investigations on single stage modified Savonius rotor*. Applied Energy 86 (2009) 1064–1073
- 
- A. PSO project "Development of Urban CO2 Neutral Light Fixture" – Application
  - B. Notes from mail correspondence with Bengt Peres, DTU Byg
  - C. Interview and correspondence with Christina Beller, DTU Vind
  - D. Interview and correspondence with Carsten Dam-Hansen, DTU Fotonik
  - E. Interviews pr. mail, Thomas Maare, Københavns Kommune
  - F. Interview Freddy Degn, Philips
  - G. PSO project "Development of Urban CO2 Neutral Light Fixture" – Commercial hybrid report
  - H. Interview pr. mail, Poul Norby, DTU Energy Conversion
  - I. Data on commercial hybrid systems
  - J. Data gathered on the different commercial systems