

VCSELs with a high-index-contrast grating for mode-division multiplexing

Ran, Qijiang; Chung, Il-Sug

Publication date:
2013

Document Version
Publisher's PDF, also known as Version of record

[Link back to DTU Orbit](#)

Citation (APA):
Ran, Q., & Chung, I-S. (2013). VCSELs with a high-index-contrast grating for mode-division multiplexing [Sound/Visual production (digital)]. SPIE Photonics West : High Contrast Metastructures II, San Francisco, California, United States, 05/02/2013

DTU Library Technical Information Center of Denmark

General rights

Copyright and moral rights for the publications made accessible in the public portal are retained by the authors and/or other copyright owners and it is a condition of accessing publications that users recognise and abide by the legal requirements associated with these rights.

- Users may download and print one copy of any publication from the public portal for the purpose of private study or research.
- You may not further distribute the material or use it for any profit-making activity or commercial gain
- You may freely distribute the URL identifying the publication in the public portal

If you believe that this document breaches copyright please contact us providing details, and we will remove access to the work immediately and investigate your claim.

8633-08

VCSEL with a high-index-contrast grating for mode-division multiplexing

Qijiang Ran and Il-Sug Chung

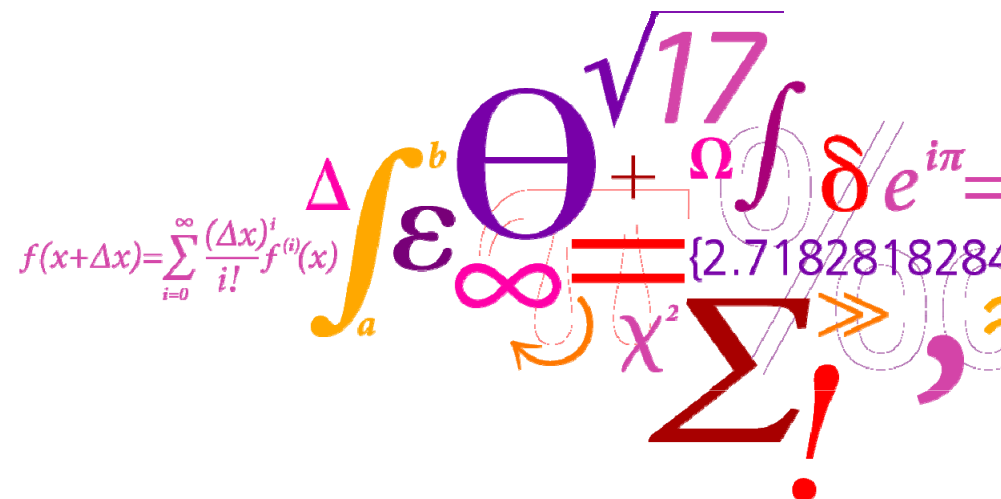

Outline

- Spatial degree of freedom for higher bandwidth
- Prior methods for exciting LP01 modes
- Proposed way: Reflectivity-modulated HCG VCSELs
- Results and discussion
- Summary

Using spatial degree of freedom

- Space division multiplexing

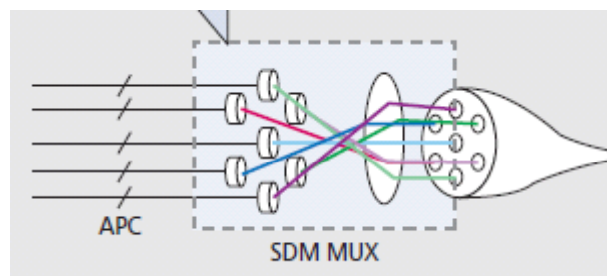
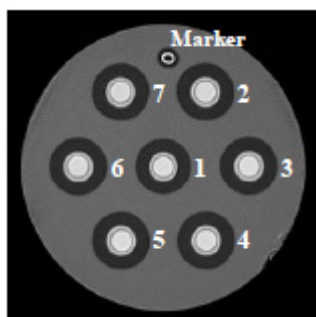

Morioka et al., IEEE ComMag S31 (Feb 2012)
 Sakaguchi et al., OFC, PDPB6 (2011)

- Mode division multiplexing

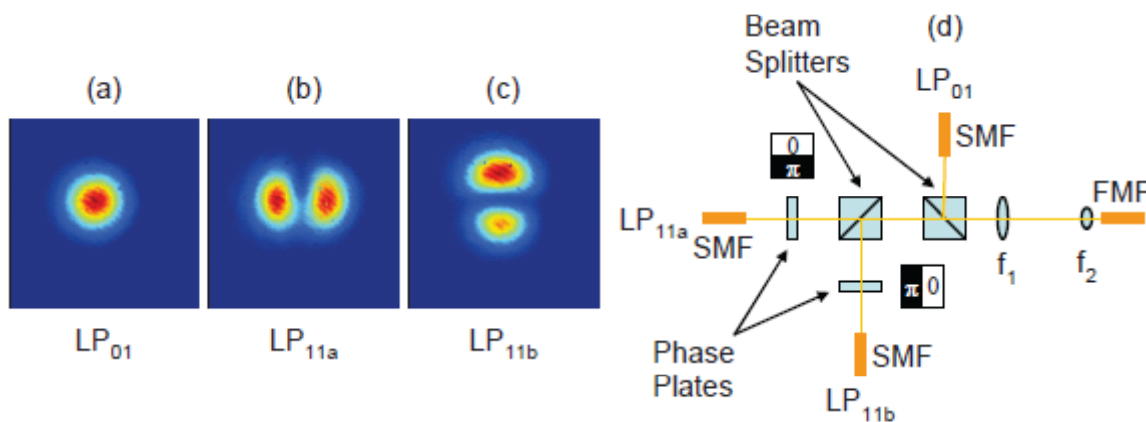

Randel et al., Opt Express **19**, 16697 (2011)

Exciting LP_{11} modes

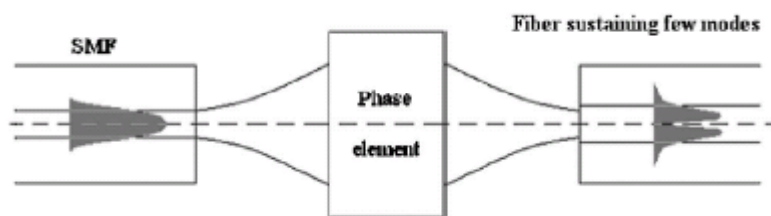
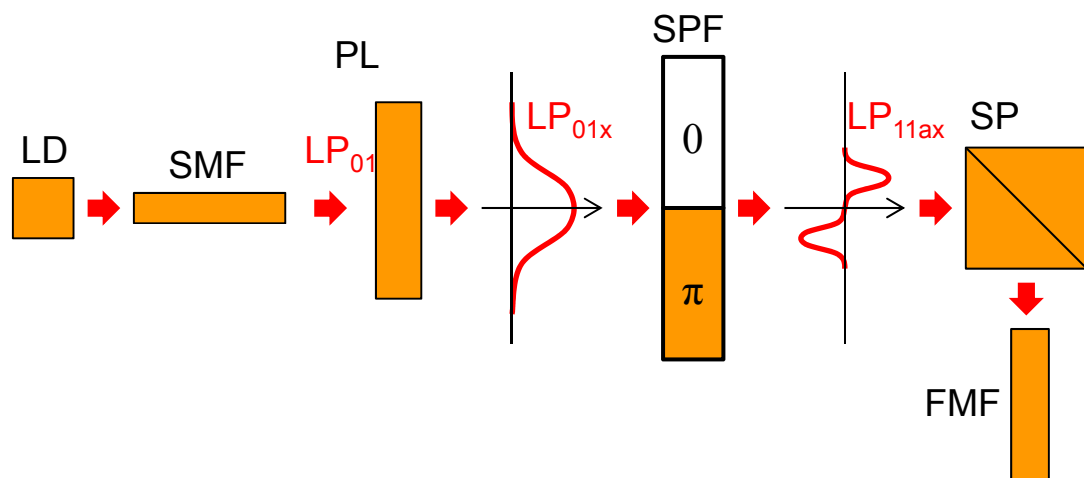

Randel et al., Opt Express **19**, 16697 (2011)

Mohammed et al., Opt Eng **45**, 074602 (2006)

Exciting LP_{11} modes

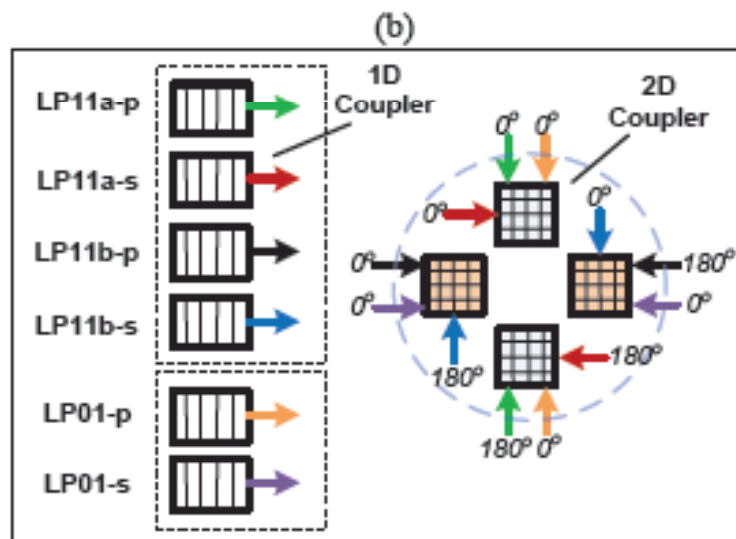
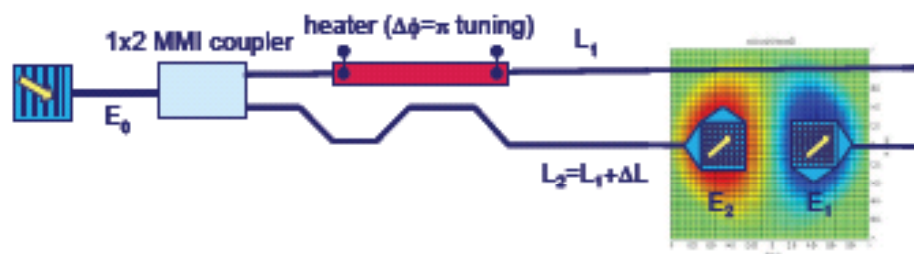

(d)

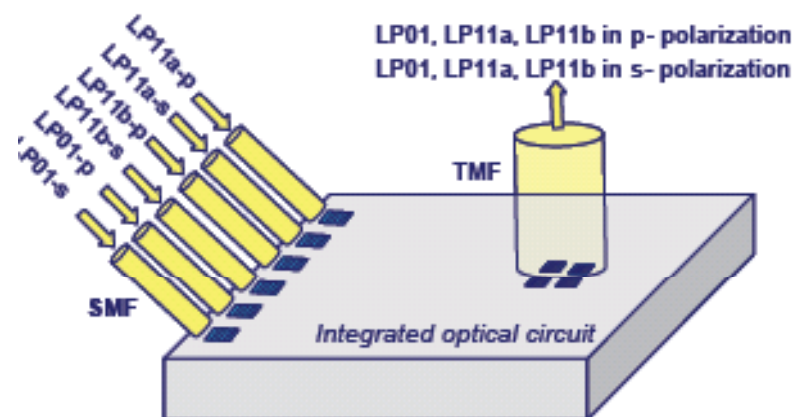

Chen et al., ACP Tech dig, OSA, ATTh2B.4 (2012)

Proposed monolithic approach

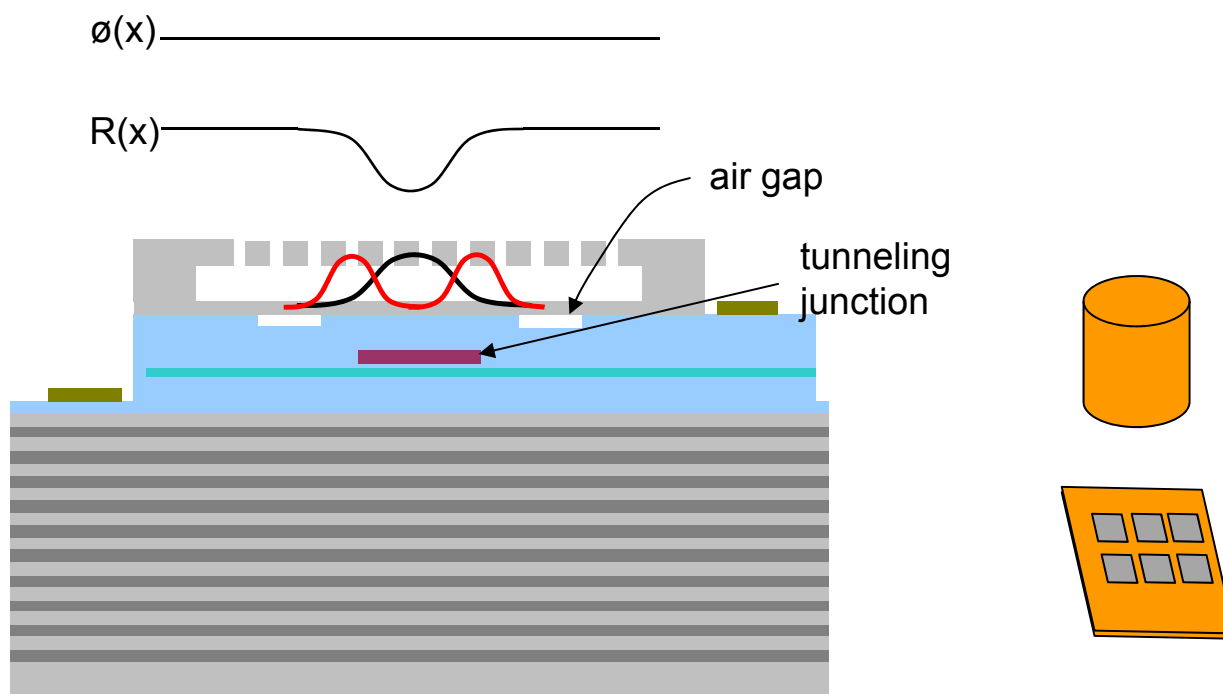

Modulation of phase profile

Engineering phase profile while keeping reflectivity profile constant.

Local phase and reflectivity is determined by local grating parameters.

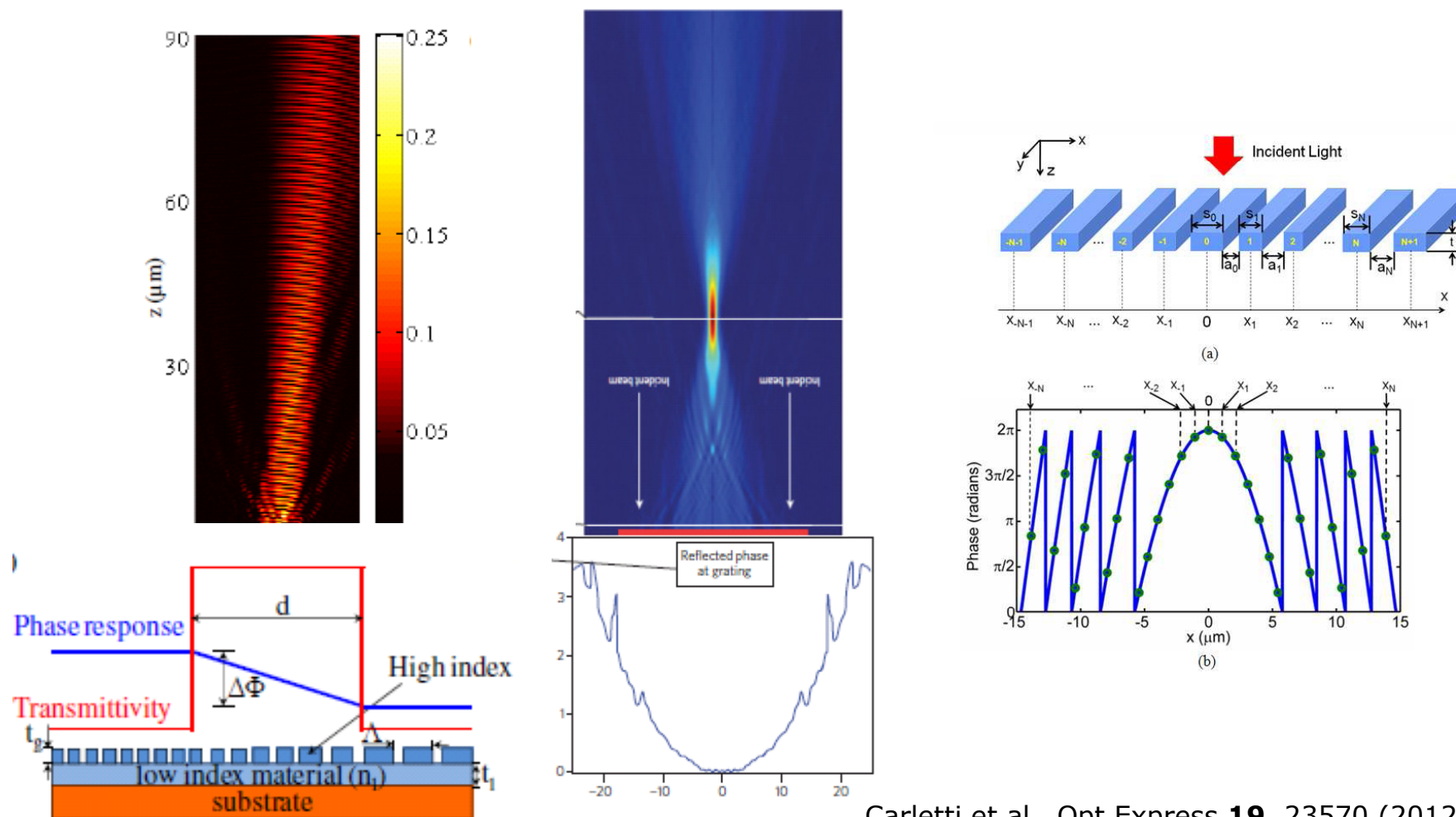

Carletti et al., Opt Express **19**, 23570 (2012).
 Fattal et al, Nat Photon **4**, 466 (2011)
 Lu et al, **4**, 466, Nat Photon (2011)

Modulation of reflectivity profile

Idea: Controlling local R profile while keeping phase profile.

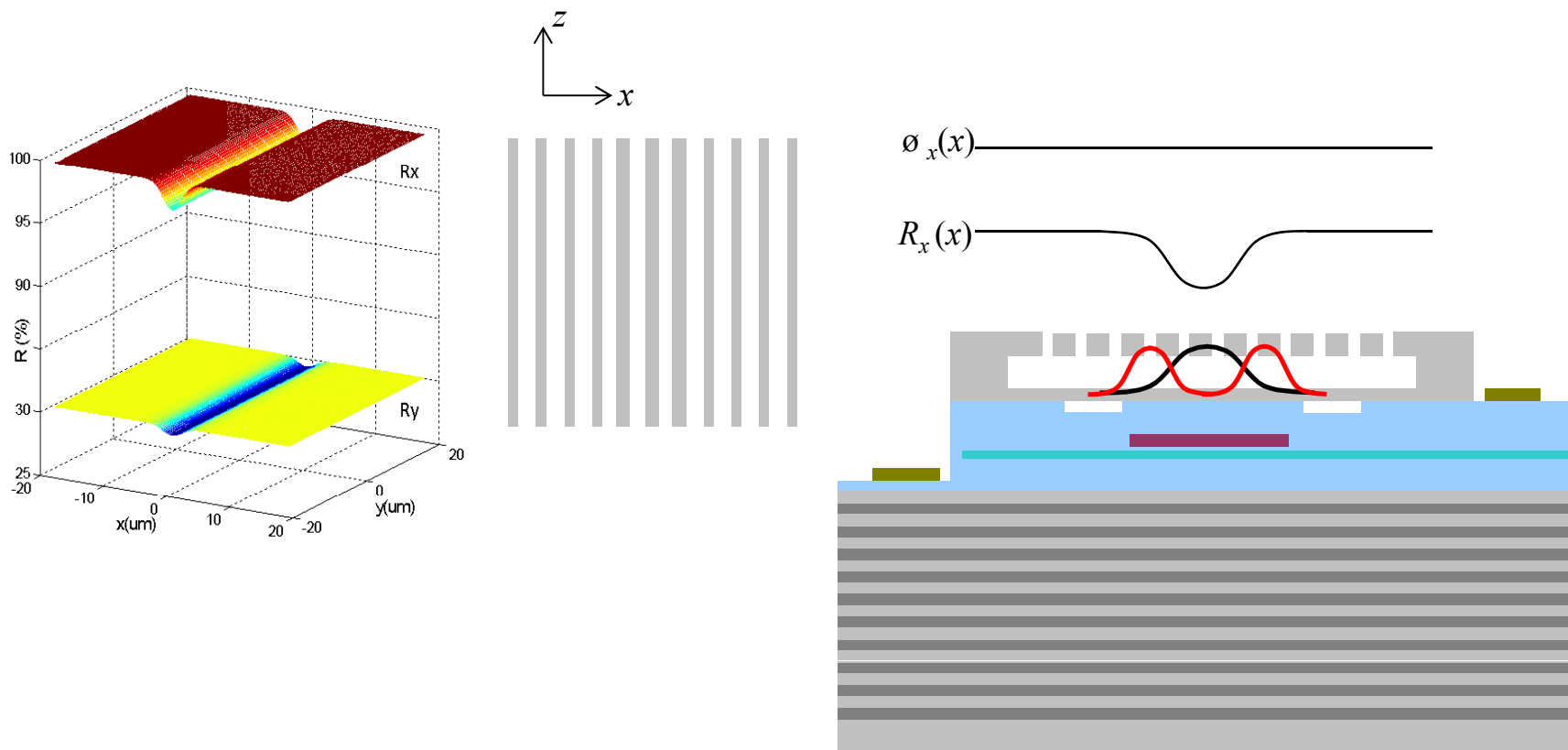

Proposed way

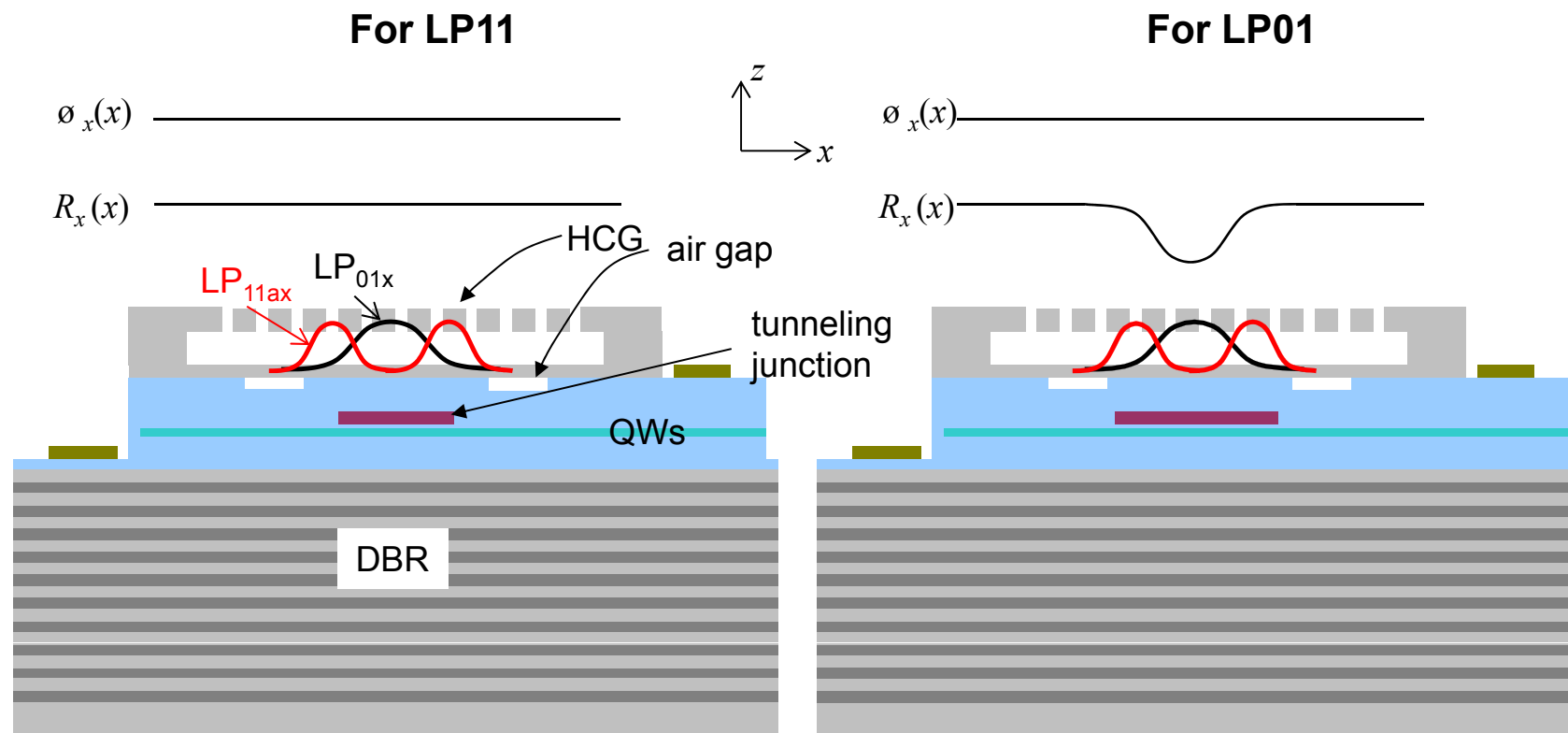

Selective pumping + k-selection

- Strongly enhanced single-mode strength
- 115% (TJ) + 65% (HCG) = 215% (HCG TJ)
- The HCG region is much larger than the optical modes.
- Selective pumping + inherent HCG mode selection brings synergy.

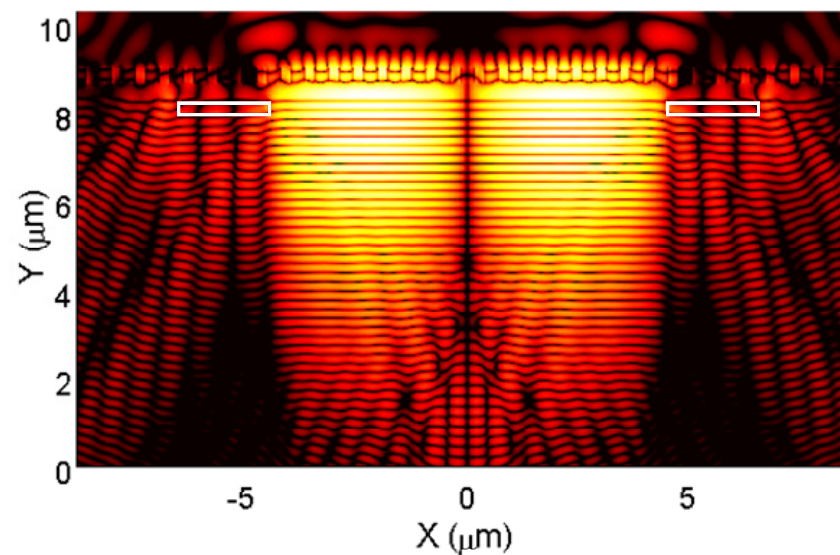
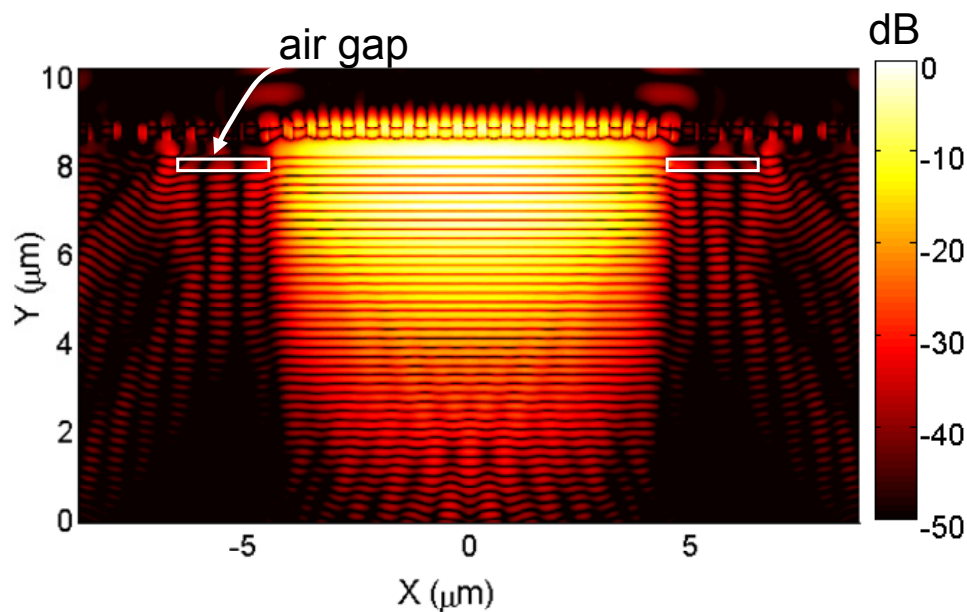

Selecting LP01ax

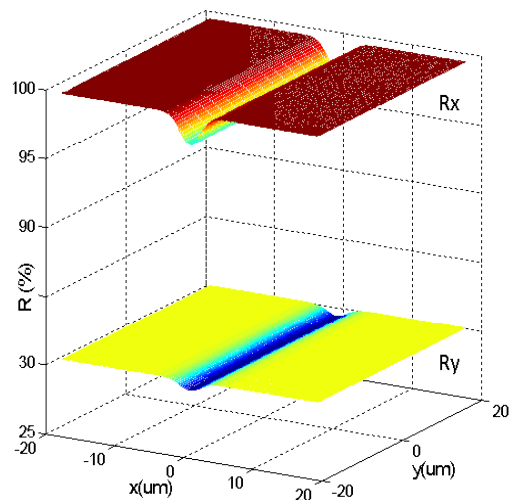

$R_x \sim 99.5\%$, $R_y \sim 30\%$

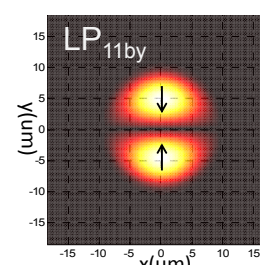
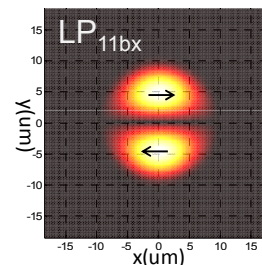
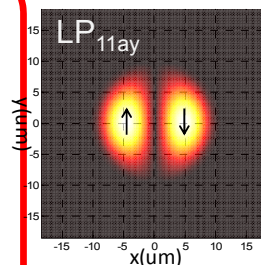
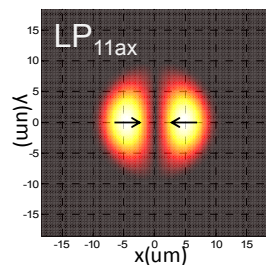
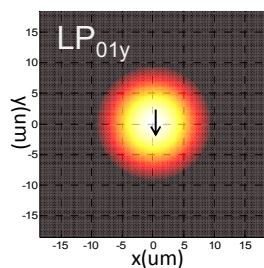
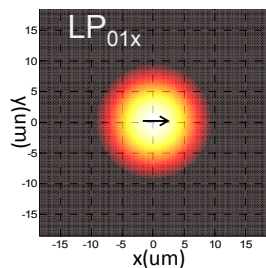
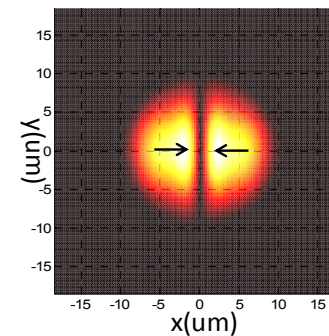
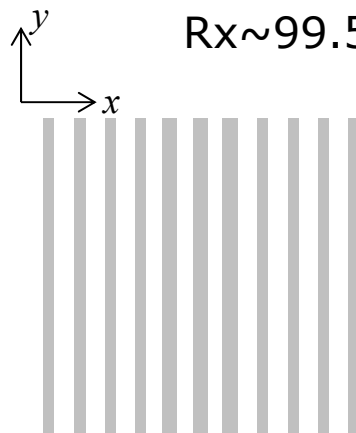

R_{mod} 98.8 %

30.1 %

99.5 %

30.3 %

98.7 %

30.0 %

g_{th} 990 cm^{-1}

73598 cm^{-1}

559 cm^{-1}

73193 cm^{-1}

1052 cm^{-1}

73801 cm^{-1}

S=77%

Selecting other LP01 modes

LP_{ay}

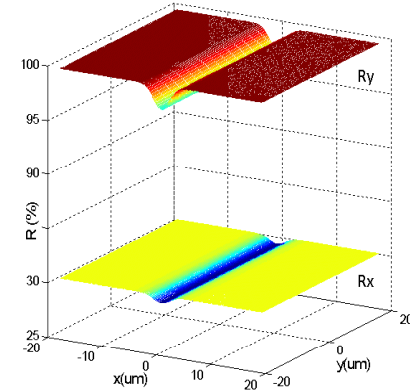
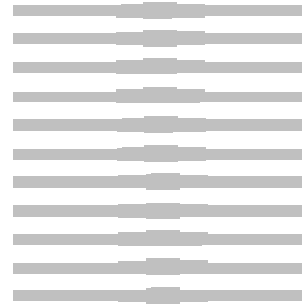
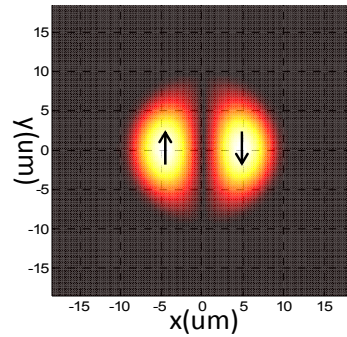

LP_{bx}

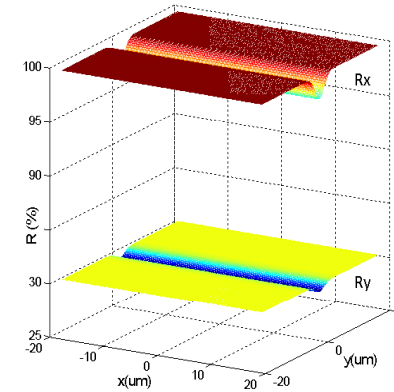
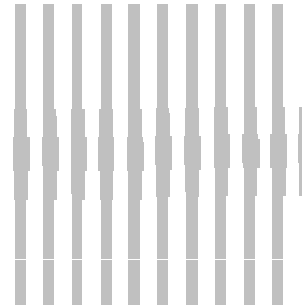
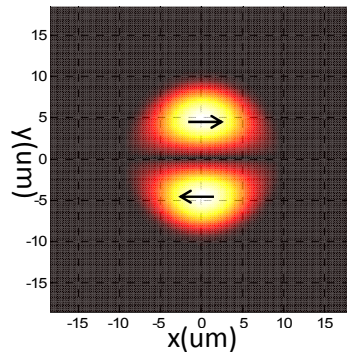

LP_{by}

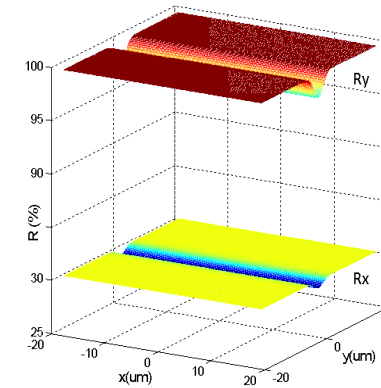
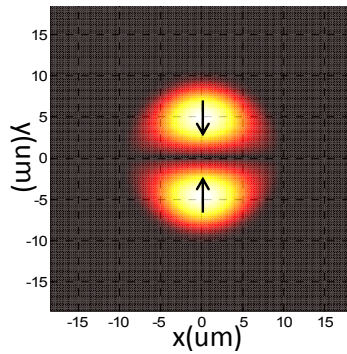

Summary

- Shaping reflectivity profile of a HCG VCSEL enables to selectively emit LP01 modes
 - Moderate single mode operation for LP01 modes
 - Very strong single-mode operation for LP11 modes
- Possibility of combining beam tilting