

## Implementation of IEC Standard Models for Power System Stability Studies

**Margaris, Ioannis; Hansen, Anca Daniela; Bech, John ; Andresen, Björn ; Sørensen, Poul Ejnar**

*Published in:*

Proceedings of 11th International Workshop on Large-Scale Integration of Wind Power into Power Systems

*Publication date:*  
2012

[Link back to DTU Orbit](#)

*Citation (APA):*

Margaris, I., Hansen, A. D., Bech, J., Andresen, B., & Sørensen, P. E. (2012). Implementation of IEC Standard Models for Power System Stability Studies. In Proceedings of 11th International Workshop on Large-Scale Integration of Wind Power into Power Systems

## DTU Library

Technical Information Center of Denmark

---

### General rights

Copyright and moral rights for the publications made accessible in the public portal are retained by the authors and/or other copyright owners and it is a condition of accessing publications that users recognise and abide by the legal requirements associated with these rights.

- Users may download and print one copy of any publication from the public portal for the purpose of private study or research.
- You may not further distribute the material or use it for any profit-making activity or commercial gain
- You may freely distribute the URL identifying the publication in the public portal

If you believe that this document breaches copyright please contact us providing details, and we will remove access to the work immediately and investigate your claim.

# Implementation of IEC Standard Models for Power System Stability Studies

Ioannis D. Margaris<sup>1</sup>, Anca D. Hansen<sup>1</sup>, John Bech<sup>2</sup>, Björn Andresen<sup>2</sup>, Poul Sørensen<sup>1</sup>

<sup>1</sup> Technical University of Denmark  
Department of Wind Energy  
Roskilde, Denmark  
iomar@dtu.dk,anca@dtu.dk,posq@dtu.dk

<sup>2</sup> Siemens Wind Power A/S  
E W EN OEN DES ESG 2  
Denmark  
john.bech@siemens.com, bjoern.andresen@siemens.com

**Abstract**— This paper presents the implementation of the generic wind turbine generator (WTG) electrical simulation models proposed in the IEC 61400-27 standard which is currently in preparation. A general overview of the different WTG types is given while the main focus is on Type 4B WTG standard models, namely a model for a variable speed wind turbine with full scale power converter WTG including a 2-mass mechanical model. The generic models for fixed and variable speed WTGs models are suitable for fundamental frequency positive sequence response simulations during short events in the power system such as voltage dips. The general configuration of the models is presented and discussed; model implementation and results are provided in order to illustrate the range of applicability of the generic models under discussion.

**Keywords**- standard wind turbine models; power system stability studies, Type 4 wind turbine

## I. INTRODUCTION

Wind power generation represents significant amount of power system production capability in many large interconnected power systems and novel ancillary services are increasingly provided by wind turbine generators (WTGs) posing serious challenges in modeling and validation procedures of the models used in relevant power system studies. Development of generic models for modern wind power generation is becoming a necessity for Transmission System Operators (TSOs) and Distribution System Operators (DSOs) in order to perform reliable dynamic analysis of the power system. Dynamic wind power generation models are often available in commercial simulation software platforms, e.g. Siemens PSS®E, DigSILENT PowerFactory, Eurostag®, GE PSLF etc. as well as in user-defined applications in own-built or commercially available softwares including PSCAD®, MATLAB-Simulink etc. The level of detail and the amount of input data required for such models is under continuous revision due to changes in the relevant power system technologies. The response of the generic models applied in

power system stability studies and the applicability of these models in various cases have to be carefully assessed in order to ensure reliable evaluation of the critical operating scenarios of the power.

The International Electrotechnical Commission (IEC) specifies in Part 1 of the IEC 61400-27 series wind turbine models as well as validation procedures which can be applied in power system stability studies i.e. large-disturbance short term voltage stability, rotor angle stability, frequency stability, small-disturbance voltage stability phenomena. Typical events in the power system which are often simulated include, among others, short-circuits, loss of generation or loads, system separation in two synchronous areas etc.

The Western Electricity Coordinating Council (WECC) - Renewable energy Modeling Task Force (REMTF) has also been working towards the development of generic models in power system simulations for wind turbine generators. These models have been extensively described in [10]. According to the definition given in [13] the term *generic* refers to a *model that is standard, public and not specific to any vendor*. Therefore, for different parameters given the models should be able to emulate the response of a wide range of equipment.

The paper is organized as follows: Section II provides the WTG model structure and implementation in the dedicated power system commercial simulation software DigSilent PowerFactory (PF). The dynamic response of the Type 4B WTG model during fault events in the grid is discussed in Section III and conclusions regarding the IEC standard modeling approach are briefed in section IV.

## II. MODEL DESCRIPTION

### A. General Structure of WTG models

Based on the IEEE definition, there are four wind turbine types which are commercially available:

- *Type 1*: Fixed speed wind turbine with asynchronous generators directly connected to the grid, i.e. without power converter. Type 1A refers to wind turbines without fault-ride through (FRT) capability while Type 1B wind turbines are equipped with blade angle FRT control.
- *Type 2*: Partially variable speed wind turbine with wound rotor asynchronous generator, blade angle control and variable rotor resistance (VRR).
- *Type 3*: Variable speed wind turbine with wound rotor asynchronous generator, direct connection of the stator to the grid and connection of the rotor through a back-to-back power converter. This type is usually referred to as doubly-fed asynchronous generator (DFAG) wind turbine.
- *Type 4*: Variable speed wind turbines with synchronous or asynchronous generator connected to the grid through a full scale power converter. There are two different models of Type 4 WTGs, Type 4A where the aerodynamic and mechanical parts are neglected and Type 4B which includes a 2-mass mechanical model assuming constant aerodynamic torque.

The general structure of the generic models for all types of WTGs is given in Figure 1.

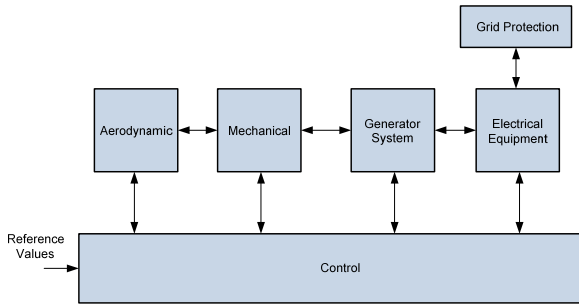

Figure 1. General model structure of IEC 61400-27-1 electrical simulation models for WTGs, [1]

### B. Structure and implementation of Type 4B WTG model

The basic configuration of a Type 4B wind turbine is shown in Figure 2. The generator can be either synchronous or induction while the mechanical parts of the wind turbine can be included or not, depending on the presence of a chopper in the converter system or not. Type 4 wind turbines without chopper typically induce power oscillations after the occurrence of a fault which are due to torsional excited in the drive train of the wind turbine.

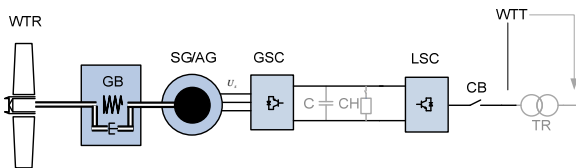

Figure 2. Electrical and mechanical components of Type 4B WTGs, [1]

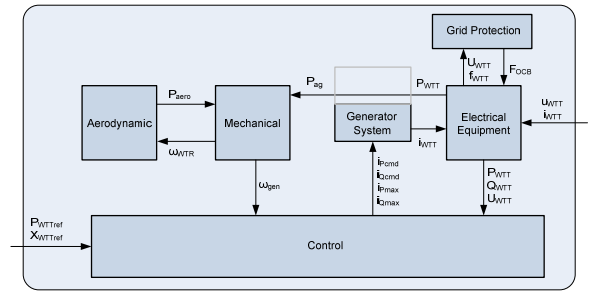

Figure 3. Runtime wind turbine Type 4 model structure, [1]

Figure 3 shows the following blocks which are included in the WTG model:

- *Aerodynamic*, which is modeled through a constant aerodynamic torque model assuming short time period of events under study e.g. voltage dips.
- *Mechanical*, which is modeled via a 2-mass equivalent. The two masses correspond to the high speed mass of the turbine and the low speed rotor of the generator. The 2-mass equivalent is considered sufficient for the scope of studies described in the IEC Part 1 document for standard models, [].
- *Generator system*, which is modeled via the static generator component in DIgSilent PowerFactory software including a current limiter. The static generator is typically used in any kind of static (no rotating) generator modeling. In Type 4 WTGs the response, seen from the grid side, is determined by the full converter attached to the generator allowing for use of the static generator component.
- *Control system*, which includes the active power and reactive power control loop, see also Fig. 5 and 6.
- *Protection system*, which models the grid under/over voltage and under/over frequency protection functions. The protection limits as well as the time of disconnection are determined based on measurements of the voltage and frequency at the WTG terminal bus.

The mechanical system illustrated in Figure 4 is represented through a 2-mass model in order to account for the torsional shaft oscillations excited in the mechanical system in case of a torque imbalance e.g. during a fault in the grid – see Figure 4. The parameters required for the mechanical system are given in Table I.

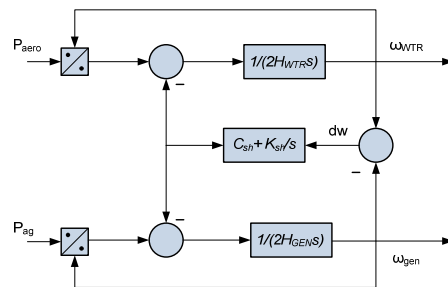

Figure 4. Two mass model for the mechanical system as implemented in DIgSILENT PowerFactory software

TABLE I. PARAMETER LIST FOR TWO-MASS MODEL

Symbol	Unit	Description	Source
$H_{WTR}$	p.u.	Inertia constant of wind turbine rotor	Manufacturer
$H_{gen}$	p.u.	Inertia constant of generator	Manufacturer
$k_{sh}$	p.u.	Shaft stiffness	Manufacturer
$c_{sh}$	p.u.	Shaft damping	Manufacturer

The active power control loop is illustrated in Figure 5 and mainly consists of a 1<sup>st</sup> order filter with the time constant of the power lag and a rate limiter for the active power reference of the wind turbine. Note that the generator speed is used as an input to the active power control loop in order to account for the electromechanical oscillations especially during faults. These are thus present in the active current output command signal  $iPcmd$  of the loop. The LVRT signal is calculated in the reactive power control block, see Figure 6, and is used to freeze the state of the filter when low voltage is detected.

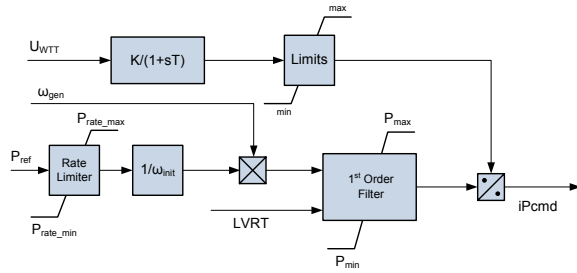

Figure 5. Active power control loop implemented in DIGSILENT PowerFactory software

The reactive power control loop includes several options for controlling the reactive power and/or voltage as well as the LVRT capability function. As illustrated in Figure 6 and Table II further below, one can select different control configurations for the reactive power, i.e. open / closed loop operation, voltage / without voltage control, power factor / reactive power control operation mode. The external reference signal  $X_{WTT,ref}$  can be either voltage difference or reactive power command from a wind power plant controller if available.

The reactive current control signal  $iQcmd$  is defined as the combination of three components, namely the voltage dependent current  $iqv$ , the frozen current  $iqfrz$  and the constant post fault current  $iqpost$ . The industry currently offers three different options regarding the reactive current output both during normal and LVRT conditions. The results presented in this paper have been calculated based on the following selection:

- During the fault the current output is defined as  $i_{Qcmd} = i_{qfrz} + i_{qv}$
- After the fault, for time duration  $T_{post}$  the current output is defined as  $i_{Qcmd} = i_{qfrz} + i_{qpost}$

The LVRT detection blocks outputs the signal LVRT and the signal FpostFRT in one of the 3 following stages:

- 0: during normal operation ( $U_{WTT} > U_{dip}$ ) – LVRT=0
- 1: during fault ( $U_{WTT} \leq U_{dip}$ ) – LVRT=1
- 2: post fault – the system stays in this stage with  $U_{WTT} > U_{dip}$  for  $t = T_{post}$ . In this stage only FpostFRT=1

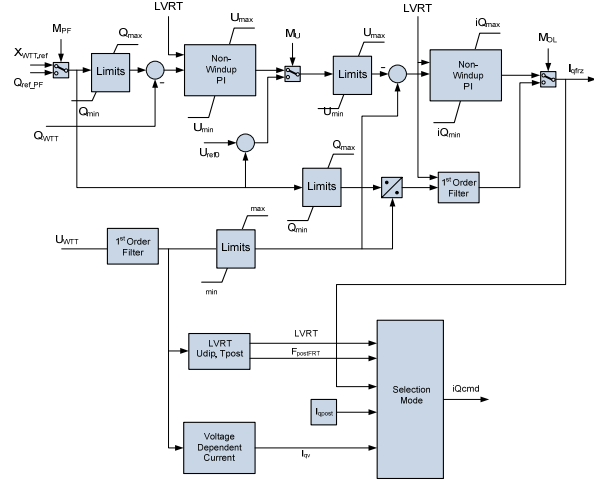

Figure 6. Reactive power control loop implemented in DIGSILENT PowerFactory software

TABLE II. REACTIVE POWER CONTROL LOOP OPERATION MODES

Selection Factor	Mode of operation in the Q control loop	
	Value: 1	Value: 0
$M_{PF}$	Power Factor	Q control
$M_U$	Voltage Control	Without Voltage Control
$M_{OL}$	Open Loop	Closed Loop

The current outputs of the active and reactive power control loops are inputs to a current limiter, see Figure 7, which includes the following components:

- Limitation of the maximum continuous current during normal operation at the wind turbine terminals,  $i_{max}$
- Limitation of the maximum current during a voltage dip at the wind turbine terminals,  $i_{max,dip}$
- The maximum current ramp rate the wind turbine terminals,  $di_{max}$
- Prioritization of active or reactive power during LVRT operation
- Voltage dependency of the active and reactive current limits provided by lookup tables  $i_{p,VDL}$  and  $i_{q,VDL}$  respectively

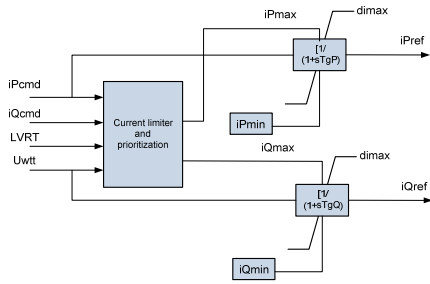

Figure 7. Active and reactive current limiter and prioritization implemented in DlgSILENT PowerFactory software

It is noted here that the current limiter defines to a great extent the response of the wind turbine model especially during voltage dips and thus the limits for the currents need to be defined in a reliable and realistic way.

### III. CASE STUDY

The simulations in this section have been carried out using the test system described in [13], see also Fig. 10. The test system includes a Thevenin equivalent model for the external grid, two step-up transformers, the collection cable, a circuit breaker and the wind turbine generator, which is represented by the built-in static generator model in PowerFactory. The parameters of the electrical components of the test system can be found in [13].

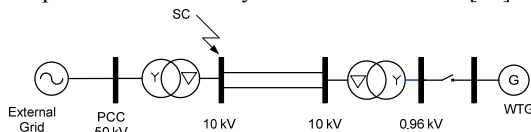

Figure 8. Single line diagram of the test system

A typical 3-phase short circuit of 400 ms duration has been simulated at the MV bus, as illustrated in Figure 8. Section III.A includes result when priority of the reactive current component is applied in the current limitation block during the LVRT period while Section III.B illustrates a comparison between active and reactive power prioritization. This feature provides with the capability to represent a Type 4 WTG response during voltage dips for different grid codes' requirements regarding the active/reactive current injection during the low voltage instant.

#### A. Results for $Q$ priority in the current limiter

In this first set of results reactive power current is prioritized during the voltage dip. Figures 9-11 illustrate the voltage, the reactive current components as well as the LVRT and FpostFRT detection signals. As soon as the short circuit is cleared the FpostFRT signal remains equal to one for  $T_{post}=1$  sec.

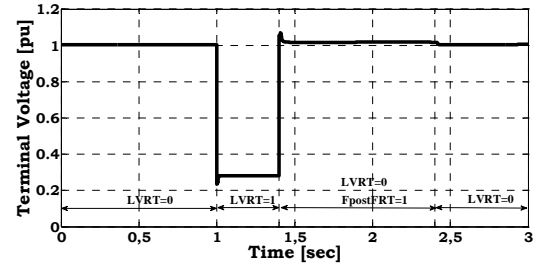

Figure 9. Voltage at the WT terminals during and short after the short circuit

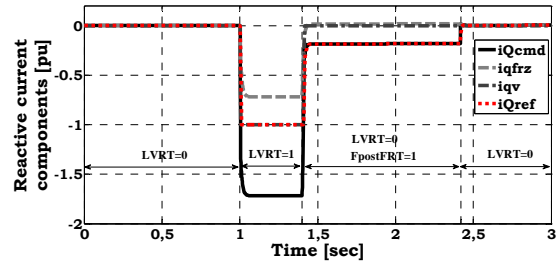

Figure 10. Reactive current components during and short after the short circuit

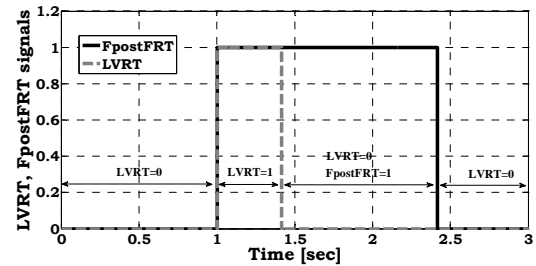

Figure 11. The LVRT and FpostFRT signals during and short after the short circuit

The active and reactive power response of the WTG is given in Fig. 12 and 13 respectively. Due to the reactive power prioritization, during the voltage dip reactive current is injected as defined in the LVRT strategy applied – see also Section II above –, forcing active power to zero as long as the voltage remains low. At the fault clearance, the sudden increase in the voltage at the WTG terminal leads to a surge of reactive power while in the post fault period, as long as the FpostFRT signal remains equal to one, reactive power is injected to the grid offering voltage support to the grid. Before and after the fault, the Power Factor control has been chosen, thus the WTG keeps unity power factor.

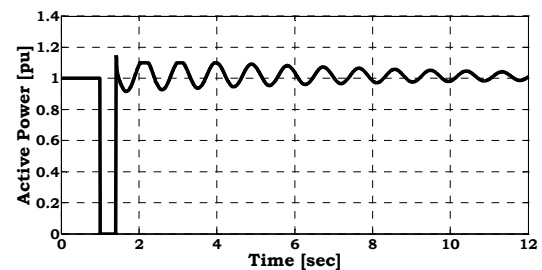

Figure 12. Active power response during and short after the short circuit

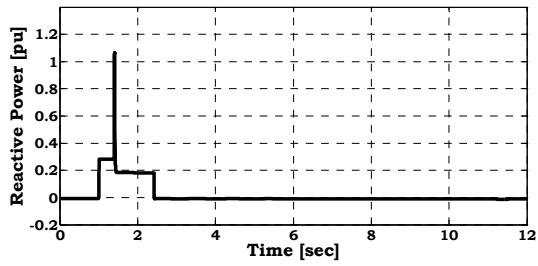

Figure 13. Reactive power response during and short after the short circuit

Fig. 14 shows the results for the aerodynamic and airgap power, which are inputs to the mechanical system of the model. The airgap power is calculated at the static generator, thus is equal to the electrical power injected to the grid as no losses are taken into account. The torsional oscillations, which were simulated using the 2-mass model for the mechanical model, are visible in the rotor speed as well as in the electrical power produced by the WTG, see Fig. 12 and 15. At the fault instant, the low voltage leads to a sudden decrease of the electrical torque resulting in the corresponding increase of the rotor speed as long as the voltage remains low. The oscillation frequency modes of these oscillations can be calculated based on the parameters of the mechanical system, [10].

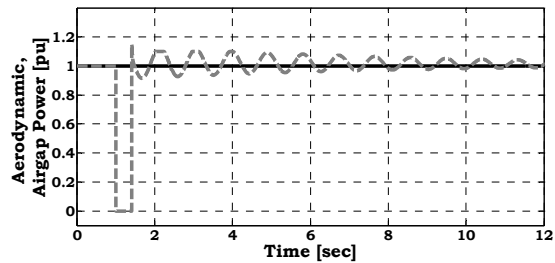

Figure 14. Aerodynamic and airgap power during and short after the short circuit

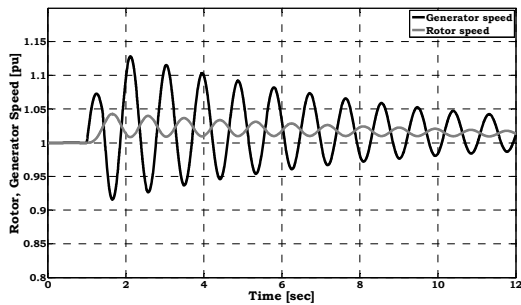

Figure 15. Generator and rotor speed during and short after the short circuit

### B. Comparison between P and Q priority in the current limiter

This section includes results for the same short circuit presented above when active power prioritization is selected in the current limiter block described in section II. As shown in Fig. 16, when active power is prioritized, the reactive power injection is almost zero during the low voltage instant leading to lower voltage minimum compared to the case of reactive power prioritization.

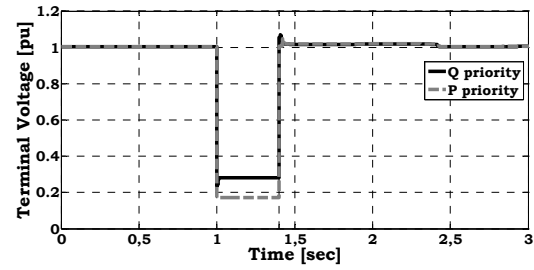

Figure 16. Voltage at the WT terminals during and short after the short circuit when active or reactive power is prioritized

Fig. 17 and 18 illustrate the active and reactive power response when active or reactive power is prioritized in the current limiter. In the first case, active power is injected to the grid despite the low voltage during the fault. At the fault clearance, reactive power is provided equally for active or reactive power prioritization while active power is oscillating following the torsional modes described in section IIIA.

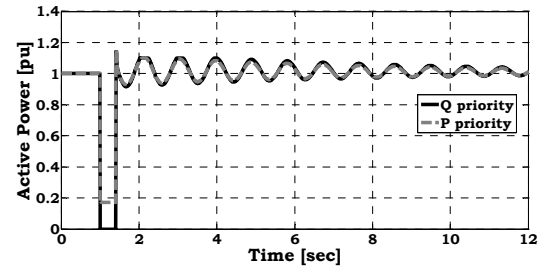

Figure 17. Active power response during and short after the short circuit when active or reactive power is prioritized

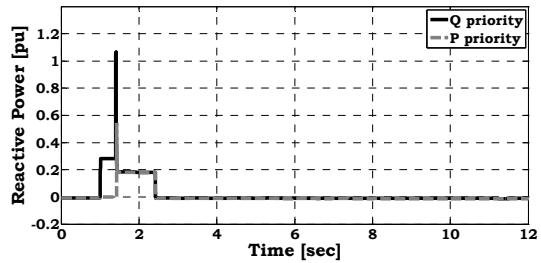

Figure 18. Reactive power response during and short after the short circuit when active or reactive power is prioritized

## IV. CONCLUSIONS

In this paper the implementation and performance of the standard IEC proposed Type 4B model for WTGs has been described and assessed through simulations in the dedicated simulation software platform DlgSilent PowerFactory. The general structure of the standard models defined in Part 1 of the IEC 61400-27 series has been presented.

The standard Type 4B model for WTGs includes a constant aerodynamic torque model, the active and reactive power control loop, a 2-mass mechanical model, the static generator system including the current limiter with prioritization of active or reactive power and the protection function for under/over voltage and frequency. The reactive power loop comprises a LVRT control strategy which

defines the reactive current output of the controller during and short after a voltage dip at the wind turbine terminals.

Results from a short circuit simulated were shown for the main electrical variables of the system and a comparison has been presented to illustrate the prioritization function of active or reactive power, which is part of the current limiter block. The performance of the model during and short after the voltage dip is considered realistic as compared to field measurements for voltage dips provided by manufacturers in relevant publications. Validation of this standard Type 4B model implemented in DIgSILENT PowerFactory simulation platform against field measurements is further needed to ensure the applicability of this model in power system studies. Following the validation procedure described in Part 1 of the IEC 61400-27 series, the model will soon be tested against real measurements provided by manufacturers and the parameterization of the model will be thus improved to match a real WTG performance during transient events in the power system e.g. voltage dips.

#### ACKNOWLEDGEMENT

The authors would like to thank the IEC TC88 WG27 for providing the draft of the relevant IEC standard. The work presented in this paper was performed during the project ForskIN Energinet.dk 2009-10179 "Pre-standardization of wind power modeling" co-funded by Vestas, SIEMENS Wind Power and DONG Energy.

#### REFERENCES

- [1] IEC 61400-27 Committee Draft, Wind Turbines Part 27-1: Electrical simulation models for wind power generation Wind turbines, IEC Std. committee Draft (CD) 88/424/CD January 2012.
- [2] A. Ellis, Y. Kazachkov, E. Muljadi, P. Pourbeik, and J. Sanchez-Gasca, "Description and technical specifications for generic

- WTG models-a status report," in Power Systems Conference and Exposition (PSCE), 2011 IEEE/PES, Mar. 2011, pp. 1–8.
- [3] P. Sørensen, B. Andresen, J. Fortmann, K. Johansen, and P. Pourbeik, "Overview, status and outline of the new iec 61400 -27 electrical simulation models for wind power generation," in The 10th International Workshop on Large-Scale Integration of Wind Power into Power Systems, Aarhus, Denmark, Oct. 2011.
- [4] V. Akhmatov, "IEC type 1 and type 2 generic wind turbine models: Draft 01," Tech. Rep., Dec. 2010.
- [5] IEC 61400-21 ed. 2, Wind Turbine Generator System–Part 21: Measurement and Assessment of Power Quality Characteristics of Grid Connected Wind Turbines, IEC Std., 2008.
- [6] T. Thiringer and J. Luomi, "Comparison of reduced-order dynamic models of induction machines," Power Systems, IEEE Transactions on, vol. 16, no. 1, pp. 119–126, Feb 2001.
- [7] PowerFactory User's Manual, DIgSILENT GmbH, Gomaringen, Germany, May. 2011, version 14.1.
- [8] A. D. Hansen, F. Iov, P. Sørensen, N. Cutululis, C. Jaush, and F. Blaabjerg, "Dynamic wind turbine models in power system simulation tool DIgSILENT," Risø National Laboratory, Roskilde, Denmark, Tech. Rep. Risø-R-1400, Aug. 2007.
- [9] P. Sørensen, A. D. Hansen, P. Christensen, M. Mieritz, J. Bech, B. B. Jensen, and H. Nielsen, "Simulation and verification of transient events in large wind power installations," Risø National Laboratory, Roskilde, Denmark, Tech. Rep. Risø-R-1331, Oct. 2003.
- [10] T. Ackermann, Wind power in power systems, 2<sup>nd</sup> edition, John Wiley & Sons, 2012.
- [11] V. Akhmatov, "Modelling of variable-speed wind turbines with doubly fed induction generators in short-term stability analysis," in Proceedings of the 3rd International Workshop on Transmission Networks for Offshore Wind Farms, Apr. 2002.
- [12] P. Kundur, Power System Stability and Control. McGraw-Hill, 1994.
- [13] NERC IVGTF 1-1, Standard Models for Variable Generation, May 18, 2010, [http://www.nerc.com/docs/pc/ivgtf/IVGTF\\_Report\\_PhaseII\\_Task1-1\\_Final\(5.24\).pdf](http://www.nerc.com/docs/pc/ivgtf/IVGTF_Report_PhaseII_Task1-1_Final(5.24).pdf)