

Technical University of Denmark



NOx reduction by ozone injection and direct plasma treatment

Stamate, Eugen; Salewski, Mirko

Published in:
Proceedings of ESCAMPIG XXI

Publication date:
2012

Document Version
Publisher's PDF, also known as Version of record

[Link back to DTU Orbit](#)

Citation (APA):
Stamate, E., & Salewski, M. (2012). NOx reduction by ozone injection and direct plasma treatment. In Proceedings of ESCAMPIG XXI

DTU Library

Technical Information Center of Denmark

General rights

Copyright and moral rights for the publications made accessible in the public portal are retained by the authors and/or other copyright owners and it is a condition of accessing publications that users recognise and abide by the legal requirements associated with these rights.

- Users may download and print one copy of any publication from the public portal for the purpose of private study or research.
- You may not further distribute the material or use it for any profit-making activity or commercial gain
- You may freely distribute the URL identifying the publication in the public portal

If you believe that this document breaches copyright please contact us providing details, and we will remove access to the work immediately and investigate your claim.

NO_x reduction by ozone injection and direct plasma treatment

E. Stamate^{1*} and M. Salewski²

¹ Department of Energy Conversion and Storage, Technical University of Denmark, Frederiksborgvej 399, Roskilde 4000, Denmark

² Department of Physics, Technical University of Denmark, Frederiksborgvej 399, Roskilde 4000, Denmark

(*) eust@dtu.dk

NO_x reduction by ozone injection and direct plasma treatment is investigated for different process parameters in a 6 m long serpentine reactor. Several aspects including the role of mixing scheme, water vapours, steep temperature gradient and time dependent NO_x levels are taken into consideration. The process chemistry is monitored by FTIR, chemiluminescence and absorption spectroscopy. The kinetic mechanism is also investigated in 3D simulations.

NO_x affects the quality of air, soil and water through acid rain with direct negative influence on human health [1]. Available technologies for NO_x reduction include selective catalytic reduction [2], selective non-catalytic reduction [3], low-temperature oxidation by ozone [4], non-thermal plasma [5], electron beam irradiation and several hybrid techniques [6]. Despite of this variety, none of these methods is free of trade-offs and limitations. The NO_x oxidation method by ozone injection has several advantages compared with other techniques, as e.g. direct ozone production in the reactor, because the plasma discharge is kept clean, and the removal rate of NO is higher than for direct oxidation methods where the reverse reactions occur to reform NO and NO₂ due to O radicals. However, the low-temperature oxidation technique is still relatively expensive, a fact that requires further process optimization including development of cost effective hybrid configurations [7].

This work presents measurements and simulations regarding NO_x reduction by low temperature ozone injection and direct plasma treatment taking into account the role of the mixing scheme, water vapours, steep temperature gradients and time dependent NO_x concentrations.

The reactor was designed as a flexible and mobile system, and its general layout is presented in Fig. 1. For compactness the reaction tube was built in a serpentine configuration of more than 6 m length as to provide a residence time larger than 5 sec. The inner diameter is 100 mm, and several sampling ports are placed at certain locations including gas sampling for ozone, NO, NO₂, FTIR measurements and temperature measurements by thermocouples. Cross-sectional ports are also available. The carrier gas flow (up to 200 SLM) is dry air that can be mixed with NO and NO₂ under controlled humidity and temperature distribution along the reactor. The mixing zone allows different configurations for mixing schemes and humidity control via water spray (not shown). This zone also includes an interchangeable element that can include additional plasma discharges or surfaces with catalytic properties. The flue gas can be heated up to 130°C using two heaters of 200 W and 700 W, respectively, which are placed in series before the mixing zone. The temperature profile along the reactor is controlled using heating tape. A Wideco ® ozone generator

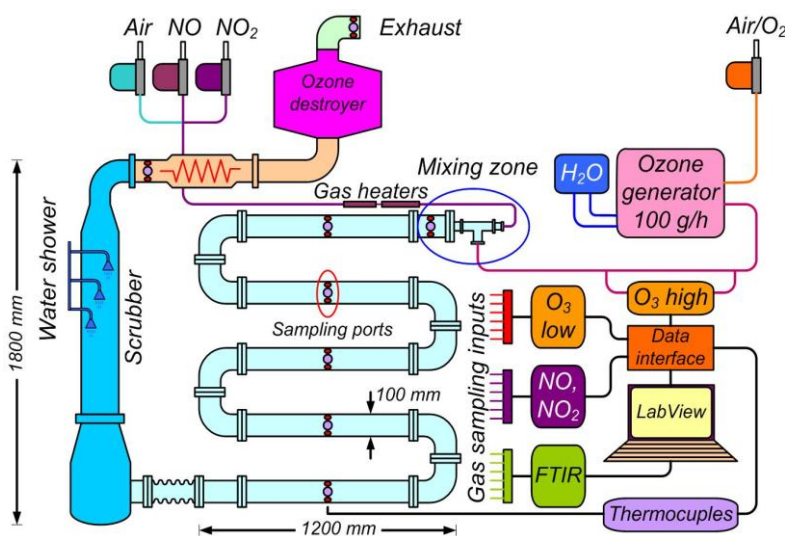

Fig. 1 Schematic diagram of the reactor.

A Wideco ® ozone generator

that can provide up to 100g/h of ozone when operated in O₂ and 40 g/h in air is used for the system. The ozone concentration is monitored by BMT ® ozone sensors before the mixing and along the reactor. NO and NO₂ are measured using a chemiluminescence device (CLD 62 manufactured by Eco Physics ®) up to 5000 ppm. After oxidation in the reactor the flue gas passes through a wet scrubber to dissolve the N₂O₅, and the remaining ozone is destroyed by a catalytic filter before releasing the treated gas into the atmosphere using a blower (not shown). Flue gases for different sources including complex composition such as SO_x or VOC can also be investigated. A broad range of measurements will be presented during the conference.

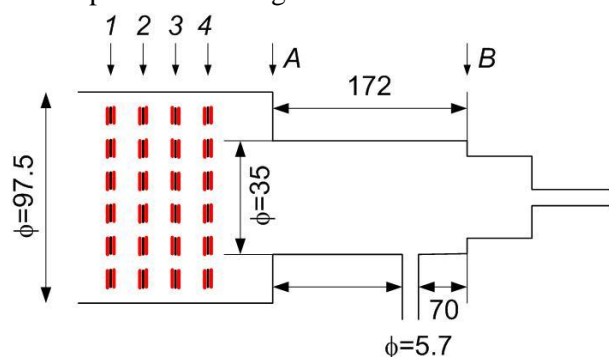

Fig. 2 Geometrical details for the mixing zone including serial arrangement of DBDs.

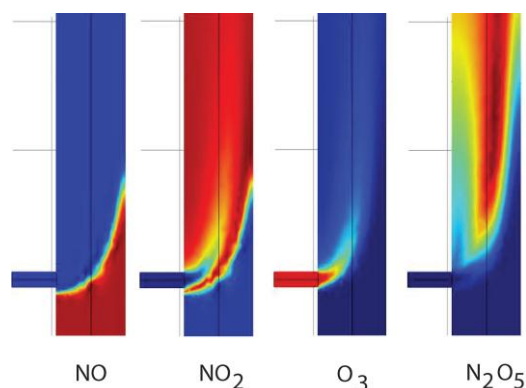

Fig. 3 Concentrations of NO, NO₂, O₃ and N₂O₅ for J=4, corresponding to A-B region in Fig. 2.

In the computational analysis, we solve the incompressible Reynolds-averaged Navier-Stokes equations and an averaged transport equation for a passive scalar. Turbulence is accounted for through turbulent diffusion coefficients for the flow and the passive scalar in the framework of a k-epsilon turbulence model. The flow is modelled using COMSOL ®. The most important parameters to characterize the flow in the mixing section are the Reynolds numbers of the jet and the crossflow and the velocity ratio between jet and crossflow. The jet Reynolds number is about 40000, and the channel Reynolds number is about 100000. The flow is therefore turbulent. The two sudden expansions before the mixing region also induce turbulence due to flow separation at the edge of the sudden expansion. Unsteady shear layers are formed here that increase the turbulence intensity. Geometrical details for the mixing chamber are shown in Fig. 2 (dimensions in mm). The mixing is increased by increasing the velocity ratio and we found that the optimum velocity ratio is about J=3 to 4. NO, NO₂, O₃ and N₂O₅ for J=4 are presented in Fig. 3 which shows that NO is rapidly consumed in the near-field of the jet in cross-flow, NO₂ is present in the crossflow stream but is also generated in the near-field region of the jet in crossflow due to the rapid oxidation of the NO. The O₃ decays very fast due to NO oxidation as to form N₂O₅.

A serial sets of dielectric barrier discharges (DBD) is used for direct flue gas treatment and hybrid configurations (see 1-4 in Fig. 2). Each set is composed of two stainless steel meshes covered with dielectric and operated in negative pulse mode.

This work was partially financed by the InterRegional IV Batilc Sea Programme 2007-2013 under the PlasTEP project.

References

- [1] Orlandini I and Riedel U, J Phy. D: Appl Phys 33 (2000) 2467-2474.
- [2] Chen J P and Yang R T, Appl Catal A 80 (1992) 135-148.
- [3] Lyon R K, US Patent No. 3900554 (1975).
- [4] Fu Y, Diwekar U M, Adv Envr Res 8 (2003) 173-196.
- [5] Mukkavilli S, Lee C K, Varghese K, and Tavlarides L L, IEEE Trans Plasma Sci 16 (1988) 652-660.
- [6] Chang S J, Loay P C, Nagai K, Yoshioka T, Aoki S, Moezawa A, IEEE Trans Ind Appl 32 (1996)131-7.
- [7] Stamate E, Chen W, Jørgensen L, Jensen T K, Fateev A, Michelsen P K, Fuel 89 (2010) 978-985.