



## **Towards a plant-wide Benchmark Simulation Model with simultaneous nitrogen and phosphorus removal wastewater treatment processes.**

**Flores-Alsina, Xavier; Ikumi, David; Batstone, Damien; Gernaey, Krist V.; Brouckaert, Chris; Ekama, George A.; Jeppsson, Ulf**

*Publication date:*  
2012

[Link back to DTU Orbit](#)

### *Citation (APA):*

Flores-Alsina, X., Ikumi, D., Batstone, D., Gernaey, K., Brouckaert, C., Ekama, G. A., & Jeppsson, U. (2012). Towards a plant-wide Benchmark Simulation Model with simultaneous nitrogen and phosphorus removal wastewater treatment processes.. Paper presented at 2012 IWA World Water Congress and Exhibition, Busan, Korea, Republic of.

## **DTU Library** Technical Information Center of Denmark

---

### **General rights**

Copyright and moral rights for the publications made accessible in the public portal are retained by the authors and/or other copyright owners and it is a condition of accessing publications that users recognise and abide by the legal requirements associated with these rights.

- Users may download and print one copy of any publication from the public portal for the purpose of private study or research.
- You may not further distribute the material or use it for any profit-making activity or commercial gain
- You may freely distribute the URL identifying the publication in the public portal

If you believe that this document breaches copyright please contact us providing details, and we will remove access to the work immediately and investigate your claim.

# Towards a plant-wide Benchmark Simulation Model with simultaneous nitrogen and phosphorus removal wastewater treatment processes

Xavier Flores-Alsina<sup>1</sup>, David Ikumi<sup>2</sup>, Damien Batstone<sup>3</sup>, Krist V. Gernaey<sup>4</sup>, Chris Brouckaert<sup>5</sup>, George A. Ekama<sup>2</sup> and Ulf Jeppsson<sup>1</sup>

<sup>1</sup> Department of Measurement Technology and Industrial Electrical Engineering (MIE), Division of Industrial Electrical Engineering and Automation (IEA), Lund University, Box 118, SE-221 00 Lund, Sweden.

<sup>2</sup> Water Research Group, Department of Civil Engineering, University of Cape Town, Rodenbosh, 7700, South Africa.

<sup>3</sup> Advanced Wastewater Management Centre, University of Queensland, Brisbane, QLD 4072, Australia.

<sup>4</sup> Center for Process Engineering and Technology (PROCESS), Department of Chemical and Biochemical Engineering, Technical University of Denmark, Building 229, DK-2800 Kgs. Lyngby, Denmark.

<sup>5</sup> Pollution Research Group, School of Chemical Engineering, University of KwaZulu-Natal, Durban, 4041, South Africa.

**Abstract:** It is more than 10 years since the publication of the Benchmark Simulation Model No 1 (BSM1) manual (Copp, 2002). The main objective of BSM1 was creating a platform for benchmarking carbon and nitrogen removal strategies in activated sludge systems. The initial platform evolved into BSM1\_LT and BSM2, which allowed the evaluation of monitoring and plant-wide control strategies, respectively. The fact that the BSM platforms have resulted in 300+ publications demonstrates the interest for the tool within the scientific community. In this paper, an extension of the BSM2 is proposed. This extension aims at facilitating simultaneous carbon, nitrogen and phosphorus (P) removal process development and performance evaluation at a plant-wide level. The main motivation of the work is that numerous wastewater treatment plants (WWTPs) pursue biological phosphorus removal as an alternative to chemical P removal based on precipitation using metal salts, such as Fe or Al. This paper identifies and discusses important issues that need to be addressed to upgrade the BSM2 to BSM2-P, for example: 1) new influent wastewater characteristics; 2) new (bio) chemical processes to account for; 3) modifications of the original BSM2 physical plant layout; 4) new/upgraded generic mathematical models; 5) model integration; 6) new control handles/sensors; and 7) new extended evaluation criteria. The paper covers and analyzes all these aspects in detail, identifying the main bottlenecks that need to be addressed and finally discusses the aspects where scientific consensus is required.

**Keywords:** Modelling, Benchmarking, Phosphorus removal, Model-based evaluation, Multi-criteria decision making, Process control

## 1. INTRODUCTION

Over the past decade, considerable investments have been made in acquiring knowledge of how to best perform objective benchmarking of control and monitoring strategies for wastewater treatment plants (WWTPs) and how to evaluate the results using a detailed simulation protocol. The success of the COST/IWA Benchmark Simulation Models (BSMs) (e.g. Copp, 2002; Rosen *et al.*, 2004; Jeppsson *et al.*, 2007; Nopens *et al.*, 2010; Gernaey *et al.*, 2012) for control strategy and monitoring system development and evaluation clearly proves the usefulness of such tools for the wastewater research community. The BSM family consists of different standardized simulation and evaluation procedures including plant layout, simulation models and model parameters, a detailed description of the disturbances to be applied and a set of evaluation criteria for testing the relative effectiveness of simulated control/monitoring strategies in WWTPs. Internationally, more than 300 peer-reviewed papers, conference presentations and theses on work related to the benchmark systems have been published to date. The freely available simulation models are used by numerous research groups around the world for various purposes and are available as predefined software tools in several commercial WWTP simulator packages (e.g. GPS-X<sup>TM</sup>, SIMBA<sup>®</sup>, WEST<sup>®</sup>) – as well as in a stand-alone FORTRAN implementation and for the general MATLAB<sup>®</sup>/SIMULINK<sup>®</sup> platform. Implementations with varying success have also been achieved in STOAT<sup>TM</sup>, BioWin<sup>TM</sup>, AQUASIM, JASS, SciLab, EFOR<sup>TM</sup> and this year in LabVIEW<sup>TM</sup>.

The BSM1 represents the original implementation and consists of a five-reactor activated sludge plant configuration followed by a (non reactive) secondary clarifier. The BSM1 platform has been widely used in both academia and industry for unbiased comparison of control strategies (Copp, 2002). Later on, the standard activated sludge configuration of the BSM1 was modified to account for other plant configurations (Pons and Poutier, 2004; Gernaey and Jørgensen, 2004), longer evaluation periods (Rosen *et al.*, 2004) and also to evaluate monitoring strategies (process disturbances, sensor and actuator failures) (Corominas *et al.*, 2011). Apart from evaluation of control/monitoring strategies the BSM platform has been used to evaluate different mathematical model assumptions (Menniti *et al.*, 2012), novel treatment technologies such as membrane bioreactors (Maere *et al.*, 2011), various settling descriptions (Flores-Alsina *et al.*, 2009; Ramin *et al.*, 2011) and new compounds such as greenhouse gas emissions (Corominas *et al.*, 2012) and micro-pollutants (Flores-Alsina *et al.*, 2012b).

Although being valuable tools, both BSM1 and BSM1\_LT do not allow the evaluation of control strategies on a plant-wide basis, and do not consider some of the complex non-linear effects induced by the larger external recycle streams such as digestate-reject water. Consequently, only local control strategies can be evaluated. The importance of integrated and plant-wide control strategies has been emphasized by the chemical engineering community (Skogestad, 2000) and the wastewater industry is starting to realize the benefits of such an approach. A wastewater treatment plant should be considered as an integrated process, where primary/secondary clarification units, activated sludge reactors, anaerobic digesters, thickeners, dewatering systems, storage tanks, etc. are linked together and need to be operated and controlled not as individual unit operations, but taking into account all the interactions amongst the processes. For this reason, during the last years the IWA Task Group on Benchmarking of Control Strategies for WWTP initiated discussion within the scientific community to reach a consensus on a plant-wide evaluation tool, i.e. BSM2. BSM2 increased substantially the number of control handles thereby opening the door to a new dimension of control possibilities, such as studying the impact of activated sludge control strategies on the sludge line (Jeppsson *et al.*, 2007), sludge digestion regimes and either enhanced control (Vanrolleghem *et al.*, 2010) or biological treatment (Volcke *et al.*, 2006) of the nitrogen rich digestate reject water

The BSM2 has proven useful for nitrogen (N) removing WWTPs but does not allow for evaluating the effect of potential control strategies on biological or chemical phosphorus (P) removal processes. Optimization of P removal processes is nowadays one of the key issues in many full-scale WWTPs. Indeed, biological P removal is often pursued in many WWTPs as an alternative to chemical P removal based on precipitation with metal ions, including aluminium (Al) and iron (Fe). Consequently, there is a current need for tools allowing simultaneous evaluation of combined N and P removal processes using a plant-wide perspective (Jeppsson *et al.*, 2012).

The objective of this paper is to discuss the main issues that need to be addressed to upgrade the current BSM2 platform (Jeppsson *et al.*, 2007; Nopens *et al.*, 2010; Gernaey *et al.*, 2012), for combined N and P control strategy development, analysis and evaluation (BSM2-P). This paper discusses: 1) new influent wastewater characteristics; 2) new (bio) chemical processes that should be taken into account; 3) modifications of the original BSM2 physical plant layout; 4) new/upgraded generic mathematical models; 5) model integration; 6) new control handles/opportunities; and 7) extended evaluation criteria. The new BSM2-P platform will show whether substantial improvements in combined N and P removal can be achieved when plant-wide control strategies are implemented. Furthermore, it will shed light on the existing synergies and trade-offs within environmental, economical as well as technical aspects, and on the need to reach a compromise solution in order to achieve optimal performance.

## 2. BSM2-P MODEL DEFINITION

In this section, we identify issues that need to be addressed and propose some new ideas for the final definition of the BSM2-P. It is our intention to include as many features of the BSM2 as possible in terms of process layout, reactor/settler/digester volumes and process models, although the influent composition, activated sludge configuration (an anaerobic section needs to be included to promote bio-P removal) and the performance of the anaerobic digester will be somewhat different. For this reason the overall plant behaviour will not be identical to BSM2. The main focus of this paper is related to the plant layout, process definitions, control handles, sensors, influent wastewater generation, benchmarking procedure and extended evaluation criteria.

### 2.1 Process definition

The objective pursued for the new BSM2-P is completely in line with the philosophy of the BSM2: the development of a tool that can be used to evaluate the relative performance changes of proposed control strategies rather than in every single detail simulate the 'true' behaviour of a real WWTP. Consequently, this benchmark is not designed by any national standards or design principles, but aims at describing a general plant and the main processes that may be found at WWTPs in most industrialized countries.

The new key elements that the system needs to predict are:

- Biological accumulation of P through polyphosphate accumulating organisms (PAOs);
- Chemical partitioning between the dissolved and particulate phases throughout the process, either through existing models (e.g., ASM2d), or extensions of standard models (e.g., ADM1-P (Ikumi *et al.*, 2012)).

*Plant layout.* The proposed layout of the BSM2-P WWTP is shown in **Figure 1**. The BSM2-P layout consists of a primary clarifier/pre-fermenter (PRIM/PRE-F), activated sludge section (AS), secondary settler (SEC2), a sludge thickener/flotation (THK/FLOT), an anaerobic digester (AD), a storage tank (ST) and a dewatering unit (DW).

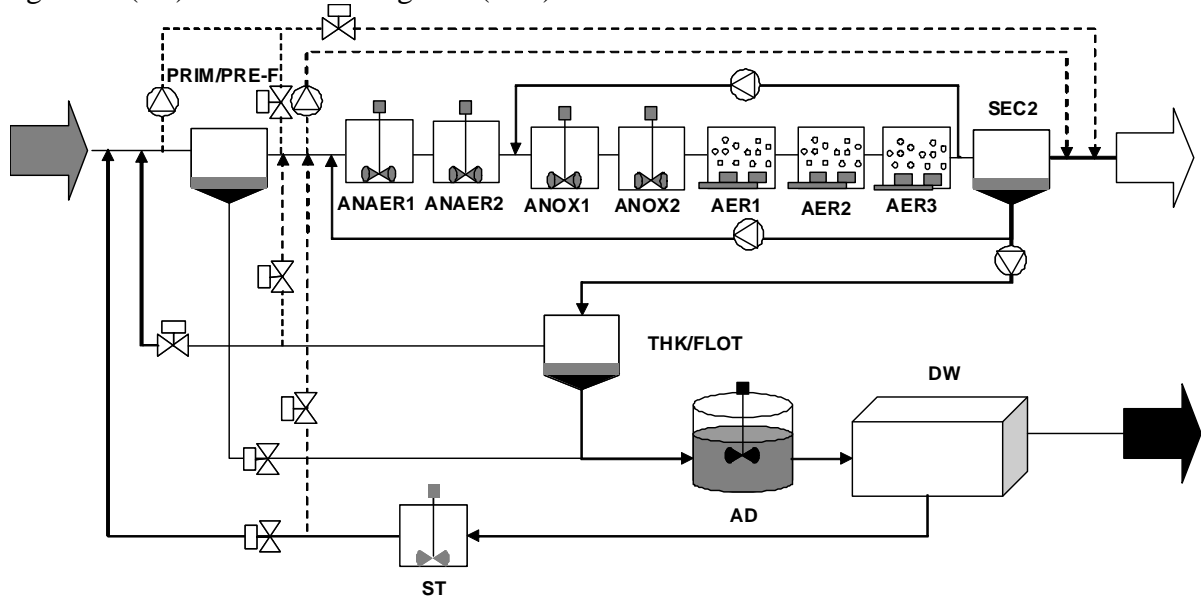

**Figure 1.** Plant layout of the proposed BSM2-P.

The plant is designed to remove organic carbon (C), N and P. In the aerobic section (AER1, 2 & 3) of the plant the organic matter and ammonia ( $\text{NH}_4^+$ ) are oxidized to carbon dioxide ( $\text{CO}_2$ ) and nitrate ( $\text{NO}_3^-$ ). In the anoxic section (ANOX1 & 2) the nitrate transported by the internal recirculation is reduced to nitrogen gas ( $\text{N}_2$ ).

P removal can be carried out in two different ways: biologically and chemically. In biological phosphorus removal (BPR), polyphosphates (PP) are incorporated into the cell biomass, which is then removed from the process as a result of sludge wasting. An anaerobic section (ANER1 & 2) without oxygen ( $O_2$ ) and nitrate ( $NO_3^-$ ) is needed to promote anaerobic P release and to provide the PAOs with a competitive advantage over other bacteria. Next, PAOs grow using intracellular storage products as a substrate during the aerobic phase, with  $O_2$  or  $NO_3^-$  as electron acceptors and take up N and P as nutrients. In chemical phosphorus removal (CPR), P in the influent wastewater is precipitated by the addition of a metal salt (which can be Al or Fe), and subsequently removed from the mixed liquor with the sludge in the SEC2. In the sludge line, the anaerobic digester converts the organic biodegradable matter, both soluble and particulate, to methane ( $CH_4$ ) and carbon dioxide ( $CO_2$ ). Since  $CH_4$  has a low solubility, most of it is released and recovered, thereby removing organic matter from the liquid phase and stabilizing any solids produced in the process. Pumps and valves in **Figure 1** indicate some control handles at the plant-wide level, but many additional control options are available within the different processes.

*Primary clarifier/pre-fermenter.* The proposed primary clarifier (PRIM) is modelled according to the principles stated in **Otterpohl and Freund (1992)**. The same approach was used in the BSM2. The main idea is based on separating the influent wastewater into water and sludge streams using a non-reactive continuous stirred tank reactor (CSTR). The model parameters are defined to produce a TSS concentration in the sludge stream equal to 3% for the average dry weather conditions, and a TSS removal efficiency of 50%. PRIM has the same physical characteristics as in BSM2 (**Jeppsson et al., 2007**). The primary clarifier can be used as a pre-fermenter to increase the acetate (VFA) and fermentable biodegradable soluble organics (FBSO) concentrations in the feed to the anaerobic (ANAER) reactor. Acid digestion/fermentation models have been developed can be used for this purpose (**Lilley et al., 1991; Skalsky and Daigger, 1995; Batstone et al., 2002**).

*Activated sludge model.* The Activated Sludge Model No 2d (ASM2d) is the selected (bio) chemical model. The ASM2d is based on the ASM2 (**Henze et al., 2000**), expanded to include the denitrifying activity of PAOs. The basic principle of BPR in the ASM2d relies on modelling P accumulating organisms with internal structure, where all the organic products are lumped into one model component named poly-hydroxy-alcanoates (PHA). PHA is formed from acetate under anaerobic conditions using the energy that becomes available from the hydrolysis of PP. PAOs can only grow (i.e. form new biomass) using cell internal organic storage material (PHA) as substrate, with oxygen or nitrate as electron acceptor. As phosphorus is continuously released by the lysis of PP, the model assumes that the organisms consume phosphate ( $PO_4^{-3}$ ) for production of biomass. The precipitation and re-dissolution of the P (CPR) is based on the assumption that it is a reverse process, which would be in equilibrium at steady state. It is important to highlight that the final ASM2d implementation in the BSM2-P platform comprises several modifications. First of all, biomass decay rates are electron-acceptor dependent (**Siegrist et al., 1999; Gernaey and Jørgensen, 2004**). Secondly, Ca, Mg, K, Fe, Al and S are modelled separately to describe different behaviour through the anaerobic process and therefore considering the interaction with S and P for Fe ions. In the sewer, Fe binds with sulphides to form iron sulphide which is then released under aerobic conditions and the Fe is free to form iron phosphates (where there is normally more Fe added). The iron phosphates then go to the digester, where most of it is released to form iron sulphide and soluble phosphates or  $Ca/Mg \cdot PO_4$  (**Ge et al., 2012**). Thirdly, a plant-wide pH module is included considering all these ions (an ionic speciation model could also be linked as the one developed for the AD system (**Batstone et al., 2012**)). Finally, TSS is formulated as a predicted variable. The original ASM2d description does include TSS, however, the description must be improved. This is mainly due to the role that the constituents of the inorganic suspended solids (ISS), measured from PP in the AS system, also play a vital role in AD total alkalinity and mineral precipitation (**Ekama and Wentzel, 2004; Ekama et al., 2006**).

*Secondary settler.* The settling description is based on the double-exponential settling velocity function of Takács *et al.* (1991). In addition, TSS sedimentation and transport is upgraded with the full set of ASM2d equations, i.e. introducing reactive settlers. Previous investigations demonstrate that reactive settlers may have an important effect on simulated growth of PAOs and formation of PHA due to the extra denitrification volume. The reactive settler must also be complemented with decay rate modifications as well as mass transfer (diffusion) limitations (Flores-Alsina *et al.*, 2012b).

*Anaerobic digester.* The 2-phase (aqueous-gas) Anaerobic Digestion Model No 1 (ADM1) (Batstone *et al.*, 2002) is extended to a 3-phase (solid-gas-liquid) model by the approach proposed by Ikumi *et al.* (2011). The consideration of three phases is through inclusion of phase transfer processes, i.e. active gas exchange through liquid to gaseous phase evolution and multiple mineral precipitation from liquid to solid or dissolution from solid to liquid phase. The original AD model is expanded with additional processes: 1) storage of PHA (phosphate release and acetate and polyphosphate uptake) by PAOs while they are still alive; 2) lysis of PAOs ( $\text{PO}_4^{-3}$ , inerts and biodegradable particulates release); 3) lysis of PP (release of  $\text{PO}_4^{-3}$ ,  $\text{Ca}^{+2}$ ,  $\text{Mg}^{+2}$  and  $\text{K}^{+}$ ); and finally 4) lysis of PHA (release of acetate). The model also considers struvite ( $\text{MgNH}_4\text{PO}_4 \cdot 6\text{H}_2\text{O}$ ), k-struvite ( $\text{MgKPO}_4 \cdot 6\text{H}_2\text{O}$ ) and calcium phosphate ( $\text{Ca}_3(\text{PO}_4)_2$ ) precipitation arising from  $\text{PO}_4^{-3}$ /PP release when wasted activated sludge is anaerobically digested. The physico-chemical model accounts for: 1) weak acid/base reaction together with the final state of equilibrium in sequential/simultaneous precipitation of multiple minerals competing for the same species; and 2) correction of ion activity, together with an ion pairing behaviour for accurate prediction of pH dynamics. The effects of the different phosphorus compounds (orthophosphate, PP) on the AD products (total alkalinity,  $\text{H}_2\text{CO}_3$  alkalinity,  $\text{H}_3\text{PO}_4$  alkalinity,  $\text{CO}_2$  partial pressure and pH) (Harding *et al.*, 2011) are considered. All these points are important since pH is highly influenced by the C and P systems. Also, the way in which P is released might have a strong influence on these calculations. Most PP is released (as  $\text{PO}_4^{-3}$ ) rapidly, with PHA uptake and later as a result of PAO death. Afterwards, P release is very gradual, i.e. mainly organically bound P released through biomass disintegration and the extent of P precipitation.

*Thickener/flotation and dewatering units.* In the thickener/flotation unit a percentage of 98% is assumed to be separated and the outflow (sludge) TSS concentration is maintained at 7%. Although gravity thickening was in the original proposal, in most Bio-P removal plants, flotation is the selected technology (Bratby *et al.*, 2008). If P rich WAS containing PAOs is thickened in gravity thickeners, the PAOs release their P in the anaerobic conditions of the gravity thickener. The dewatering unit assumes that 98% of the entering particulates are captured at a TSS concentration of 28%.

*AS/AD model interfaces.* A new set of interfaces for the modified activated sludge and the modified anaerobic digestion model will be created. The basic principles are based on the ideas that the benchmark developers described in Nopens *et al.* (2009). However, they further account for: 1) PAO; 2) PHA; 3)  $\text{PO}_4^{-3}$ ; 4) PP; 5) Metal (Ca, Mg, Fe, Al) ion phosphates and related compounds (e.g., struvite); 6) Metal (All) ion hydroxides; and finally 7) Metal (Ca, Mg, K) carbonate ( $\text{CO}_3^{2-}$ ) (Batstone *et al.*, 2012). The ASM2d/ADM interface also removes any oxygen and nitrate from the wastewater with an associated COD reduction ( $\text{O}_2$  and  $\text{NO}_3^-$ ). At this stage  $\text{PO}_4^{-3}$  uptake would be possible. The remaining COD and N components are transformed into ADM1 state variables (proteins, lipids and carbohydrates). The ADM/ASM2d interface amalgamates the large number of ADM state variables back into the ASM2d set of variables. At all times COD, carbon, hydrogen, oxygen, nitrogen and phosphorus mass balances as well as charge balance are maintained with fully mass balanced stoichiometry for all the plant-wide physical, chemical and bioprocess reactions

*Storage tank.* A storage tank for process water (nitrogen-rich supernatant from sludge dewatering) is also included to allow for dosing of this stream into the biological treatment (either to the inlet of the primary clarifier or the inlet of the AS system). The tank is modelled as a non-reactive CSTR. A pump is utilized to transport the water from the storage tank to the biological treatment. Special measures to deal with improper operation like the complete emptying or overflowing of the tank are part of the model. The main role of such a manipulated variable is to reduce peak ammonia loads to the AS system. Further information can be found in **Jeppsson *et al.* (2007)**.

*Plant-wide P physico-chemical model.* One particular aspect of P in a plant-wide context is the opportunity to model the physico-chemistry of P as it goes through different redox stages. This is particularly important for iron, which binds with sulfide (and releases P) every time it enters a reducing environment. This clearly makes Fe act quite differently from Al as a P precipitate, and allows more opportunities for different treatment of P in digester sidestreams, as well as adding clear benefits for plant-wide modelling.

## 2.2 Influent wastewater generation

The model blocks for: 1) flow-rate generation; 2) COD and N generation; 3) temperature profile generation; and 4) flow-rate and pollutant transport defined in **Gernaey *et al.* (2011)** are used to generate the WWTP influent dynamics (12 months period output data with a 15 minutes sampling interval). Nevertheless, this influent model has to be adapted to include phosphorus dynamics. User-defined profiles based on observations made by **Butler *et al.* (1995)** describe daily, weekly and seasonal phosphorus load variations. Compared to COD and N, which have two peaks during a day (first one occurs in the morning and a smaller one in the evening), the P profile has only one peak during the late afternoon. This is mainly due to the assumption that P mainly originates from detergents used in washing machines, whereas organic matter and nitrogen are primarily originating from kitchen sinks and WCs. Ca, Mg, K, Fe, Al and S ions also have to be included in the influent since they play an important role during biological P removal. Since no information is available about their dynamics, we assume constant loads, but respecting electro-neutrality at all times. The resulting influent file contains dry weather conditions describing diurnal, weekend, holiday effects and seasonal effects. In addition, the dry weather model is complemented by a rain and storm weather generator. Thus, TSS first flush effect, dilution effect after a rainy period and the size of the sewer system can be included to influence the dynamics of the influent wastewater.

## 2.3. Sensor modelling and additional control handles

Control of simultaneous nitrogen and phosphorus removal will require a new set of sensor models to measure for example phosphate concentrations in the influent, effluent or within one of the reactors. This new set of sensors will include noise, time response, drift, signal saturation and, if not a continuous sensor, the measuring interval (**Rieger *et al.*, 2003; Rosen *et al.*, 2008**). The additional processes considered by the BSM2-P allow for more control handles than those of the BSM2. The role of several internal recycles, carbon dosing, metal dosing, aeration and sludge wastage (SRT) quantity and location (RAS/AER3) as used in many control strategies can be evaluated taking into account both nitrogen and phosphorus removal efficiencies. The activated sludge section allows for changing the external/internal recirculation patterns and to compare different phosphorus removal processes (A2/O, UCT, VIP, Johannesburg, etc.). From a plant-wide perspective by-passes and both destination and equalization of the sludge recycles can be evaluated. Finally, the overall performance of the anaerobic digester can be simulated using different feeding strategies and operating temperature regimes.

## 2.4. Temperature dependency

Temperature is included as an additional state in the influent model (Gernaey *et al.*, 2011). Two types of temperature phenomena are modelled (daily and seasonal). Temperature dependency of kinetic parameters in ASM2d/ADM-P and their extensions is included (both for biological and chemical (solubility/precipitation) processes). In addition, the effect of temperature is included in the oxygen transfer coefficient ( $K_L a$ ) and oxygen saturation constant ( $S_O^{sat}$ ). Temperature dynamics in each reactor with a defined volume is modelled by a first-order system based on the 'heat' content (T·V) of the wastewater and assuming completely mixed conditions, except for the digester, where temperature is an operating parameter.

## **3. BSM2-P BENCHMARKING PROCEDURE**

### 3.1. Implementation, initialization and simulation

BSM2-P follows the same implementation, initialization and simulation principles as BSM2. Implementation of the controllers is done by the users themselves, possible in any of the verified implementations. All the dynamic simulations proceed from steady state values. Thus, the bias due to the selection of the initial conditions in the dynamic modelling results is avoided. Only the data from the last 364 days are used for evaluation purposes.

### 3.2. Evaluation of system performance

To assess the performance of the N and P control strategies an updated set of evaluation criteria is necessary. Effluent quality index (a weighted sum of effluent TSS, COD, BOD, TKN and nitrate) should be updated including the additional P load (organic and inorganic). Additional P upgrades will be necessary for effluent violations (frequency and magnitude) and percentiles. The cost of metal salts should be included in the operational cost index (in case the user wants to evaluate chemical P precipitation). Finally, the operational risk index should be updated (Comas *et al.*, 2008), for example the PAOs potential denitrification effect should be included in the risk for rising sludge.

## **4. DISCUSSION AND CONCLUSIONS**

The paper has identified and analyzed some aspects that need to be addressed to upgrade the current version of the BSM2 towards a system that allows for simultaneous consideration of biological nitrogen and phosphorus removal. The paper identified seven different topics where change/modification/development is needed. In some cases, like the influent generation model and the evaluation criteria, models are already available and their implementations in the BSM platform are quite straightforward. For other cases, like the anaerobic digestion model and the model interfaces, complete consensus has not yet been reached and model development, coding and ring-testing are still to be carried out. Nevertheless, the authors believe that BSM2-P will be an excellent future platform for exchanging ideas, for promoting scientific discussion and results comparison related to plant-wide control of combined nitrogen and phosphorus removal systems.

## **5. REFERENCES**

- Batstone D.J., Keller J., Angelidaki I., Kalyuzhnyi S.V., Pavlostathis S.G., Rozzi A., Sanders W.T.M., Siegrist H. and Vavilin V.A. (2002). Anaerobic Digestion Model No.1 (ADM1). IWA Scientific and Technical Report No 13, IWA Publishing, London, UK.
- Batstone D.J., Amerlinck Y., Ekama G., Goel R., Grau P., Johnson B., Kaya I., Steyer J.P., Takács I., Tait S., Vanrolleghem P.A. and Volcke E. (2012). Towards a generalised physicochemical framework. *Wat. Sci. Tech.* (in press).
- Bratby J., Walker S., Barnes C. and Jones G. (2008). Float on and on: Taking flotation thickeners to the limits of performance. *Water Env. & Tech.*, July, 56-59.
- Butler D., Friedler E. and Gatt K. (1995). Characterising the quantity and quality of domestic wastewater inflows. *Wat. Sci. Tech.*, 31(7), 13-24.
- Comas J., Rodríguez-Roda I., Gernaey K.V., Rosen C., Jeppsson U. and Poch M. (2008). Risk assessment modelling of microbiology-related solids separation problems in activated sludge systems. *Env. Model. Softw.*, 23(10-11), 1250-1261.
- Corominas L., Villez K., Aguado D., Rieger L., Rosen C. and Vanrolleghem P.A. (2011). Performance evaluation of fault detection methods for wastewater treatment processes. *Biotechnology & Bioengineering.*, 108(2), 333-334.
- Corominas L., Flores-Alsina X., Snip L. and Vanrolleghem P.A. (2012). Comparison of different modelling approaches to better understand and minimize greenhouse gas emissions from wastewater treatment plants. *Biotechnology & Bioengineering* (in press).



- Copp J.B. (ed.) (2002). The COST Simulation Benchmark – Description and Simulator Manual. ISBN 92-894-1658-0, Office for Official Publications of the European Communities, Luxembourg.
- Ekama G.A. and Wentzel M.C. (2004). A predictive model for the reactor inorganic suspended solids concentration in activated sludge systems. *Water Res.*, 38(8), 4093-4106.
- Ekama G.A., Wentzel M.C. and Söttemann S.W. (2006). Tracking the inorganic suspended solids through biological treatment units of wastewater treatment plants. *Water Res.*, 40(19), 3587-3595.
- Flores-Alsina X., Comas J., Rodriguez-Roda I., Gernaey K.V. and Rosen C. (2009). Including the effects of filamentous bulking sludge during the simulation of wastewater treatment plants using a risk assessment model. *Water Res.*, 43(18), 4527-4538.
- Flores-Alsina X., Plosz B., Lindblom E., Gernaey K.V. and Jeppsson U. (2012a). Extending the BSM platform with occurrence, transport and fate of micro-pollutants using the ASM-X framework. Proc. IWA World Water Congress, Busan, Korea, 16-21 Sept. 2012.
- Flores-Alsina X., Gernaey K.V. and Jeppsson U. (2012b). Benchmarking biological nutrient removal in wastewater treatment plants: Influence of mathematical model assumptions. *Wat. Sci. Tech.*, 65(8), 1496-1505.
- Ge H., Zhang L., Batstone D., Keller J. and Yuan Z. (2012). Impact of iron salt dosage to sewers on downstream anaerobic sludge digesters: sulphide control and methane production (in preparation).
- Gernaey K.V., Jeppsson U., Vanrolleghem P.A., Copp J.B. and Steyer J.-P. (eds) (2012). Benchmarking of Control Strategies for Wastewater Treatment Plants. IWA Scientific and Technical Report, IWA Publishing, London, UK (to appear).
- Gernaey K.V., Flores-Alsina X., Rosen C., Benedetti L. and Jeppsson U. (2011). Phenomenological modelling approach to generate WWTP disturbance scenarios. *Env. Model. Softw.*, 26(11), 1255-1267.
- Gernaey K.V. and Jørgensen S.B. (2004). Benchmarking combined biological phosphorus and nitrogen removal wastewater treatment processes. *Control Eng. Pract.*, 12(3), 357-373.
- Henze M., Gujer W., Mino T. and van Loosdrecht M.C.M. (2000). Activated Sludge Models ASM1, ASM2, ASM2d and ASM3. IWA Scientific and Technical Report No 9, IWA Publishing, London, UK.
- Harding T.H., Ikumi D.S. and Ekama G.A. (2011). Incorporating phosphorus into plant wide wastewater treatment plant modelling – anaerobic digestion. Proc. IWA Watermatex2011, San Sebastian, Spain, 20-22 June 2011.
- Ikumi D., Brouckaert C.J. and Ekama G.A. (2011). Modelling of struvite precipitation in anaerobic digestion. Proc. IWA Watermatex2011, San Sebastian, Spain, 20-22 June 2011.
- Jeppsson U., Pons M.-N., Nopens I., Alex J., Copp J., Gernaey K.V., Rosen C., Steyer J.-P. and Vanrolleghem P.A. (2007). Benchmark Simulation Model No 2 – General protocol and exploratory case studies. *Wat. Sci. Tech.*, 56(8), 67-78.
- Jeppsson U., Alex J., Batstone D., Benedetti L., Comas J., Copp J.B., Corominas L., Flores-Alsina X., Gernaey K.V., Nopens I., Pons M.-N., Rodríguez-Roda I., Rosen C., Steyer J.-P., Vanrolleghem P.A., Volcke E.I.P. and Vrecko D. (2012). Quo Vadis Benchmark Simulation Models? *Wat. Sci. Tech.* (submitted).
- Lilley I.D., Wentzel M.C., Loewenthal R.E., Ekama G.A. and Marais G.v.R. (1991). Acid fermentation of primary sludge at 20°C. Proc. 2<sup>nd</sup> Water Institute of Southern Africa (WISA) conference and exhibition, Kempton Park, RSA, May 1991.
- Maere T., Verrecht B., Moerenhout S., Judd S. and Nopens I. (2011). BSM-MBR: A benchmark simulation model to compare control and operational strategies for membrane bioreactors. *Water Res.*, 45(6), 2181-90.
- Menniti A., Rieger R., Boltz J.P., Johnson B., Daigger G.T., Habermacher J., Derlon N. and Morgenroth E. (2012). Critical review on modeling of endogenous processes and the degradability of endogenous decay products. Proc. IWA/WEF WWTmod 2012, Mont-Sainte-Anne, Quebec, Canada, 26-28 Feb. 2012.
- Nopens I., Batstone D.J., Copp J.B., Jeppsson U., Volcke E., Alex J. and Vanrolleghem P.A. (2009). An ASM/ADM model interface for dynamic plant-wide simulation. *Water Res.*, 43(7), 1913-1923.
- Nopens I., Benedetti L., Jeppsson U., Pons M.-N., Alex J., Copp J.B., Gernaey K.V., Rosen C., Steyer J.-P. and Vanrolleghem P.A. (2010). Benchmark Simulation Model No 2 – Finalisation of plant layout and default control strategy. *Wat. Sci. Tech.*, 62(9), 1967-1974.
- Otterpohl R. and Freund M. (1992). Dynamic models for clarifiers of activated sludge plants with dry and wet weather flows. *Wat. Sci. Tech.*, 26(5-6), 1391-1400.
- Pons M.-N. and Potier O. (2004). Control strategy robustness with respect to hydraulics. *Control Eng. Pract.*, 12, 349-356.
- Ramin E., Sin G., Mikkelsen P.S. and Plósz B.G. (2011). Significance of uncertainties derived from settling tank model structure and parameters on predicting WWTP performance - A global sensitivity analysis study. Proc. IWA Watermatex2011, San Sebastian, Spain, 20-22 June 2011.
- Rieger L., Alex J., Winkler S., Boehler M., Thomann M. and Siegrist H. (2003). Progress in sensor technology – Progress in process control? Part I: Sensor property investigation and classification. *Wat. Sci. Tech.*, 47(2), 103-112.
- Rosen C., Jeppsson U. and Vanrolleghem P.A. (2004). Towards a common benchmark for long-term process control and monitoring performance evaluation. *Wat. Sci. Tech.*, 50(11), 41-49.
- Rosen C., Jeppsson U., Rieger L. and Vanrolleghem P.A. (2008). Adding realism to simulated sensors and actuators. *Wat. Sci. Tech.*, 57(3), 337-344.
- Siegrist H., Brunner I., Koch G., Con Phan L. and Van Chieu L. (1999). Reduction of biomass decay under anoxic and anaerobic conditions. *Wat. Sci. Tech.*, 39(1), 129-137.
- Skalsky D.S. and Daigger G.T. (1995). Wastewater solids fermentation for volatile acid production and enhanced biological phosphorus removal. *Water Environment Research*, 67(2), 230-237.
- Skogestad S. (2000). Plantwide control: the search for the self-optimizing control structure. *J. Proc. Control*, 10, 487-507.
- Takács I., Patry G.G. and Nolasco D. (1991). A dynamic model of the clarification-thickening process. *Water Res.*, 25(10), 1263-1271.
- Vanrolleghem P.A., Corominas L. and Flores-Alsina X. (2010). Real-time control and effluent ammonia violations induced by return liquor overloads. Proc. WEFTEC2010, New Orleans, Louisiana, USA, 2-6 Oct. 2010.
- Volcke E.I.P., Gernaey K.V., Vrecko D., Jeppsson U., van Loosdrecht M.C.M. and Vanrolleghem P.A. (2006). Plant-wide (BSM2) evaluation of reject water treatment with a SHARON-Anammox process. *Wat. Sci. Tech.*, 54(8), 93-100.