

Technical University of Denmark



Extrapolation Method for System Reliability Assessment A New Scheme

Qin, Jianjun ; Nishijima, Kazuyoshi; Faber, Michael Havbro

Published in:
Advances in Structural Engineering

Publication date:
2012

[Link back to DTU Orbit](#)

Citation (APA):
Qin, J., Nishijima, K., & Faber, M. H. (2012). Extrapolation Method for System Reliability Assessment: A New Scheme. *Advances in Structural Engineering*, 15(11).

DTU Library

Technical Information Center of Denmark

General rights

Copyright and moral rights for the publications made accessible in the public portal are retained by the authors and/or other copyright owners and it is a condition of accessing publications that users recognise and abide by the legal requirements associated with these rights.

- Users may download and print one copy of any publication from the public portal for the purpose of private study or research.
- You may not further distribute the material or use it for any profit-making activity or commercial gain
- You may freely distribute the URL identifying the publication in the public portal

If you believe that this document breaches copyright please contact us providing details, and we will remove access to the work immediately and investigate your claim.

Extrapolation Method for System Reliability
Assessment: A New Scheme

by

Jianjun Qin, Kazuyoshi Nishijima and Michael Havbro Faber

Reprinted from

Advances in Structural Engineering

Volume 15 No. 11 2012

MULTI-SCIENCE PUBLISHING CO. LTD.
5 Wates Way, Brentwood, Essex CM15 9TB, United Kingdom

Extrapolation Method for System Reliability Assessment: A New Scheme

Jianjun Qin^{1,*}, Kazuyoshi Nishijima² and Michael Havbro Faber²

¹Institute of Structural Engineering, ETH Zurich, Zurich, Switzerland

²Department of Civil Engineering, Technical University of Denmark, Lyngby, Denmark

Abstract: The present paper presents a new scheme for probability integral solution for system reliability analysis, which takes basis in the approaches by Naess *et al.* (2009) and Bucher (2009). The idea is to evaluate the probability integral by extrapolation, based on a sequence of MC approximations of integrals with scaled domains. The performance of this class of approximation depends on the approach applied for the scaling and the functional form utilized for the extrapolation. A scheme for this task is derived here taking basis in the theory of asymptotic solutions to multi-normal probability integrals. The scheme is extended so that it can be applied to cases where the asymptotic property may not be valid and/or the random variables are not normally distributed. The performance of the scheme is investigated by four principal series and parallel systems and some practical examples. The results indicate that the proposed scheme is efficient and adds to generality for this class of approximations for probability integrals.

Key words: system reliability, scaled probability integrals, asymptotic Laplace integral solutions, Monte Carlo simulations, meta-level representation, extrapolation scheme.

1. INTRODUCTION

1.1. Background

In the assessment of the reliability of engineered systems, the efficient evaluation of probability integrals remains a technical challenging issue. Modern structural reliability theory has provided a number of efficient approaches to this including First and Second Order Reliability Methods (FORM/SORM), probability bounds, and various Monte Carlo based sampling techniques.

In practical applications, the best choice of approach depends on the specifics of the problem, and to identify this in general it is necessary to understand the strengths and weaknesses of the different approaches in some detail. As a consequence, there is a tendency, when analyzing the reliability of complex engineered facilities such as offshore platforms, infrastructure networks and industrial facilities, to use the easily

applicable but not always efficient Monte Carlo based probability integration techniques. Even though various variance reduction schemes exist, the use of these in general adds to the need of expertise of the user. The user, on the other hand, also needs to master the engineering aspects of the modelling of the considered facility and cannot be expected also to be an expert on probability integration techniques. This leaves the generally very inefficient so-called crude Monte Carlo approach as the commonly preferred choice for probability calculations in practical applications.

Recently, Naess *et al.* (2009) and Bucher (2009) independently proposed a novel class of approaches to the evaluation of probability integrals, which in the present paper is referred to as probability integral solution by extrapolation. Following the concept underlying this class of approaches, Nishijima *et al.* (2010) propose a slightly different scheme, which can

*Corresponding author. Email address: qin@ibk.baug.ethz.ch; Fax: +41-44-633-1064; Tel: +41-44-633-4652.

be shown to have a more firm mathematical justification, and which can be applied to a broader range of systems as compared with the schemes proposed by Naess *et al.* (2009) and Bucher (2009).

1.2. Aim and Structure of the Paper

The idea underlying the class of approximations considered in the present paper is simple and appealing. First, the probability integral of interest is expressed as a function of a scaling factor. The scaling factor serves, in different ways, to scale the integral down such that it can be efficiently approximated by means of e.g. crude Monte Carlo simulation. Now, by approximating the integral in this way for a relatively few number of (low) values of the scaling factor, the idea is to fit a functional form in terms of the scaling factor to the results and to use this functional form to extrapolate the results to large values of the scaling factor. Thus, based on Monte Carlo approximations performed for probability integrals with relatively large probability contents, integrals with very small probability contents may be extrapolated – yielding a potentially very significant gain in efficiency.

There are of course various issues to be considered in using the outlined scheme. First of all, there are different ways of introducing the scaling. Secondly, there is the choice of the functional form applied as basis for the fitting. Depending on how these issues are approached, the scheme may be more or less general and efficient. In the present paper general systems are considered; probability integrals with complexly bounded integral domains, i.e. domain which may be described by unions and intersections of sub-domains.

First, a short outline of the probability integral approximations schemes proposed by Naess *et al.* (2009) and Bucher (2009) is provided; each followed by one critical example to discuss their respective limitations. Thereafter, following Nishijima *et al.* (2010) a new approach which takes basis in the theory of asymptotic integral approximations for multi-normal probability integrals (see e.g. Breitung (1984), Breitung and Hohenbichler (1989), and Hohenbichler *et al.* (1987)) is introduced and generalized also to the non-asymptotic case. The significance of the proposed scheme is investigated through an illustrative example. Thereafter, the adaptation of the scheme to the non-normal case is outlined and a proposal on how to implement the scheme into a program code is presented. The proposed scheme is tested thoroughly on a variety of examples against crude Monte Carlo simulation and also compared with the schemes of Naess *et al.* (2009) and Bucher (2009).

1.3. Problem Setting

The problem considered in the present paper is the evaluation of the probability integral I of the following form:

$$I = \int_D f_{\mathbf{X}_n}(\mathbf{x}_n) d\mathbf{x}_n \quad (1)$$

where $f_{\mathbf{X}_n}(\mathbf{x}_n)$ is the joint probability density function of random variables $\mathbf{X}_n = (X_1, X_2, \dots, X_n)^T$. The generally complexly bounded integral domain D is given as:

$$D = \left\{ \bigcup_{m=1}^M \bigcap_{j=1}^{J_m} g_{mj}(\mathbf{x}_n) < 0 \right\} \quad (2)$$

and $g_{mj}(\bullet)$ ($j = 1, \dots, J_m; m = 1, \dots, M$) are functions that jointly characterize the integral domain. In system reliability assessment, if $g_{mj}(\bullet)$ and D are adopted to describe the performance of individual components of the system (limit state functions) and the domain representing the system failure respectively, the integral I correspond to the probability of failure of a system.

The underlying assumptions in the discussion in the present paper are: first, direct numerical integration of the probability integral in the form of Eqn 1 is computationally prohibitive due to the high dimension of the integral domain; second, use of First/Second Order Reliability Methods (FORM/SORM) is not an option, since either the integral domain is too complex to identify the design point(s) with a reasonable effort, or people do not have sufficient experience on the applications of FORM/SORM or do not have access to software tools of these. Thus, Monte Carlo simulation techniques are the preferred option. Note that the schemes presented in the paper can readily be combined with importance and/or adaptive sampling techniques; however, these are assumed not to be adopted and only crude Monte Carlo simulation is considered. This is because Monte Carlo simulation is most straightforward to implement into programming codes and maybe most importantly - requiring very little expertise in the technical aspects of applied probability theory.

2. PROBABILITY INTEGRAL SOLUTION BY EXTRAPOLATION

2.1. Shifting of Integral Domain as Proposed by Naess *et al.* (2009)

2.1.1. Introduction

A new class of approach for probability integral solutions is proposed by Naess *et al.* (2009). It aims to

take advantage of the strong sides of (crude) Monte Carlo simulation and at the same time to avoid the weak points. For the purpose of illustration, the underlying idea is here introduced considering the evaluation of the probability of a component failure. Note, however, that the approach can also be applied for the evaluation of the probabilities of system failures.

Denote a set of random variables by $\mathbf{X}_n = (X_1, X_2, \dots, X_n)^T$, the limit state function by $g(\mathbf{X}_n)$ and the probability of the failure of interest by the integral $I = P[g(\mathbf{X}_n) < 0] = \int_{D=\{g(\mathbf{X}_n) < 0\}} f_{\mathbf{X}_n}(\mathbf{x}_n) d\mathbf{x}_n$. The joint probability density function of random variables \mathbf{X}_n is not limited to be multi-normal. Now, introduce a scaling factor γ (referred as λ in Naess *et al.* (2009)) and define the shifted limit state function $g(\mathbf{X}_n; \gamma)$ as:

$$g(\mathbf{X}_n; \gamma) = g(\mathbf{X}_n) - (1 - \gamma)E[g(\mathbf{X}_n)] \quad (3)$$

where $E[\bullet]$ is the expectation operator. The corresponding probability that the random variables have joint realizations in the domain $D(\gamma) = \{g(\mathbf{X}_n; \gamma) < 0\}$ is:

$$I(\gamma) = P[g(\mathbf{X}_n; \gamma) < 0] = \int_{D(\gamma)} f_{\mathbf{X}_n}(\mathbf{x}_n) d\mathbf{x}_n \quad (4)$$

The probability of failure of interest then corresponds to $I(1)$. For certain values of $\gamma (< 1)$ the values of $I(\gamma)$ are significantly larger than $I(1)$; hence, the values of $I(\gamma)$ may be easily computed by means of crude Monte Carlo method with relatively few simulations. Note that in case where $E[g(\mathbf{X}_n)]$ cannot be analytically calculated, it is evaluated also by Monte Carlo simulation. Naess *et al.* (2009) assume that the probability can be parameterized by the following form as $\gamma \rightarrow 1$ as:

$$I(\gamma) = q \exp(-a(\gamma - b)^c) \quad (5)$$

where the parameters $\boldsymbol{\theta} = (a, b, c, q)^T$ in the equation above are estimated by optimizing the fit on the log scale by minimizing the mean square error between the two sides of Eqn 5 (see details in Naess *et al.* 2009) using the set of the computed probabilities $I(\gamma)$ for several values of $\gamma (< 1)$ as $\hat{\boldsymbol{\theta}} = (\hat{a}, \hat{b}, \hat{c}, \hat{q})^T$. Then, the probability of failure of interest is obtained as:

$$I = I(1) = \hat{q} \exp(-\hat{a}(1 - \hat{b})^{\hat{c}}) \quad (6)$$

The performance of the scheme is investigated in Naess *et al.* (2009) with four practical engineering applications and it is shown that the scheme works quite convincingly. However, the extent of the viability of the scheme is not clear. In fact, it is possible that the scheme fails for some cases as is shown in the following.

2.1.2. Critical example

Let the two random variables R and S independently follow the uniform distributions in the intervals $[0.999, 1.999]$ and $[0, 1]$ respectively (the mean values of R and S are $\mu_R = 1.499$ and $\mu_S = 0.5$). Define the limit state function $g(R, S) = R - S$ and the probability of failure described by the integral (see Figure 1):

$$I = P[g(R, S) < 0] = \int_{D=\{g(R, S) < 0\}} f_R(r) f_S(s) dr ds \quad (7)$$

where $f_R(r)$ and $f_S(s)$ respectively are the probability density functions of the random variables R and S , and are written as:

$$f_R(r) = \begin{cases} 0 & (r \leq 0.99) \\ 1 & (0.99 < r \leq 1.99) \\ 0 & (r > 1.99) \end{cases} \quad (8)$$

$$f_S(s) = \begin{cases} 0 & (s \leq 0) \\ 1 & (0 < s \leq 1) \\ 0 & (s > 1) \end{cases} \quad (9)$$

Following the scheme introduced above, consider the shifted limit state function $g(R, S; \gamma) = R - S - (1 - \gamma)E[g(R, S)]$ and the probability that the two variables in the domain $D(\gamma) = \{g(R, S; \gamma) < 0\}$ is: $I(\gamma) = P[g(R, S; \gamma) < 0]$

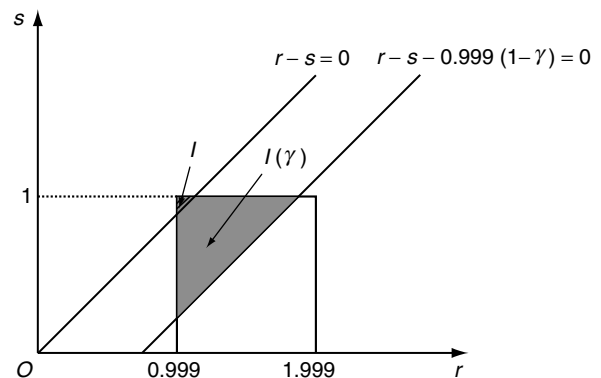

Figure 1. Original limit state function and parameterized limit state function in the illustrative critical example

$< 0] = \int_{D(\gamma)} f_R(r) f_S(s) dr ds$, where $E[g(R, S)] = \mu_R - \mu_S = 1.499 - 0.5 = 0.999$. Note that in this example $I(\gamma)$ can be analytically obtained and is equal to $(1 - 0.999\gamma)^2/2$, which thus can be utilized to assess the performance of the scheme. The parameters in Eqn 5 are estimated using the set of the values of γ and the corresponding probabilities $I(\gamma)$; the probability of failure of interest, i.e. $I(1)$, is obtained by extrapolation. Figure 2 shows the results of the extrapolation utilizing the values of γ and $I(\gamma)$ in the range of $\gamma \in [0.80, 0.95]$ (1) and $\gamma \in [0.90, 0.99]$ (2). Following the plot scheme in Naess *et al.* (2009), the horizontal and vertical axes are scaled in terms of $\ln(\gamma - \hat{\gamma})$ and $\ln(-\ln(I(\gamma)/\hat{q}))$ respectively so that if the parameterized probabilities $I(\gamma)$ are represented by Eqn 5 the points $(\gamma, I(\gamma))$ should appear on a straight line. As can be seen in Figure 2, however, whereas the points that are utilized for the curve fitting align well with a straight line, the points beyond the range of the curve fitting do not follow a straight line; the extrapolation fails.

The observation in the above example implies that the scheme for shifting the integral domains and the functional form of Eqn 5 for the extrapolation may not be suitable for certain probability integrals, and that the visual inspection on whether the points are on a straight line in the scaled plot is not always reliable. Concerning the latter, it should be mentioned that any functional form could fit points of interest to any desired degree by

introducing sufficient degrees of freedom to the functional form; however, it does not guarantee that the curve thus obtained fits the points beyond the range of the curve fitting. Thus, it is of significant importance to establish a “correct” mathematical basis for the functional form.

2.2. Scaling of the Standard Deviation of the Basic Random Variables as Proposed by Bucher (2009)

2.2.1. Introduction

Bucher (2009) considers the probability integral represented in the form of Eqn 1 in the normal space, i.e. the basic random variables $\mathbf{X}_n = (X_1, X_2, \dots, X_n)^T$ follows independent and identically normal distributed variables (i.i.d.) whose mean values are zero and standard deviations are $1/\eta_0$ (referred as σ in Bucher 2009). The value of $1/\eta_0$ may be but is not limited to one. It is noted that if the basic random variables are not normal or there are correlations among the variables these can easily be transformed into independent normal random variables. A scheme for component reliability assessment is proposed; i.e. the integral domain is defined by Eqn 2 with the restrictions of $M = 1$ and $J_1 = 1$.

A parameter η (referred as f in Bucher 2009) is adopted to scale the probability integral. The scaled probability integral $I(\eta)$ is:

$$I(\eta) = \int_D f_{\tilde{\mathbf{X}}_n}(\tilde{\mathbf{x}}_n) d\tilde{\mathbf{x}}_n = \int_D \eta^n \phi_n(\eta \mathbf{u}_n) d\mathbf{u}_n \quad (10)$$

where $\tilde{\mathbf{X}}_n = (\tilde{X}_1, \tilde{X}_2, \dots, \tilde{X}_n)^T$ is the n -dimensional independent normal random vector. Here, the mean value and the standard deviation of $\tilde{\mathbf{X}}_n$ are 0 and $1/\eta$ respectively. $\mathbf{U}_n = (U_1, U_2, \dots, U_n)^T$ is the n -dimensional independent standard normal random vector. $f_{\tilde{\mathbf{X}}_n}(\tilde{\mathbf{x}}_n)$ and $\phi_n(\eta \mathbf{u}_n)$ are the joint probability density function of $\tilde{\mathbf{X}}_n$ and $\eta \mathbf{U}_n$ respectively. The probability integral of the original problem is then $\int_D f_{\mathbf{X}_n}(\mathbf{x}_n) d\mathbf{x}_n = I(\eta_0)$. By the scaling, it is anticipated that the value of the probability integral $I(\eta)$ generally becomes larger, as the factor η becomes smaller; a critical case where this is not true is shown in Bucher (2009). Taking basis in the asymptotic theory of the multi-normal probability integral (see e.g. Breitung 1984; Breitung and Hohenbichler 1989; Hohenbichler *et al.* 1987), it is proposed that the scaled probability integral $I(\eta)$ may be approximated with two parameters A and B through the reliability index $B(\eta)$ as:

$$\beta(\eta) \approx A\eta + \frac{B}{\eta} \quad (11)$$

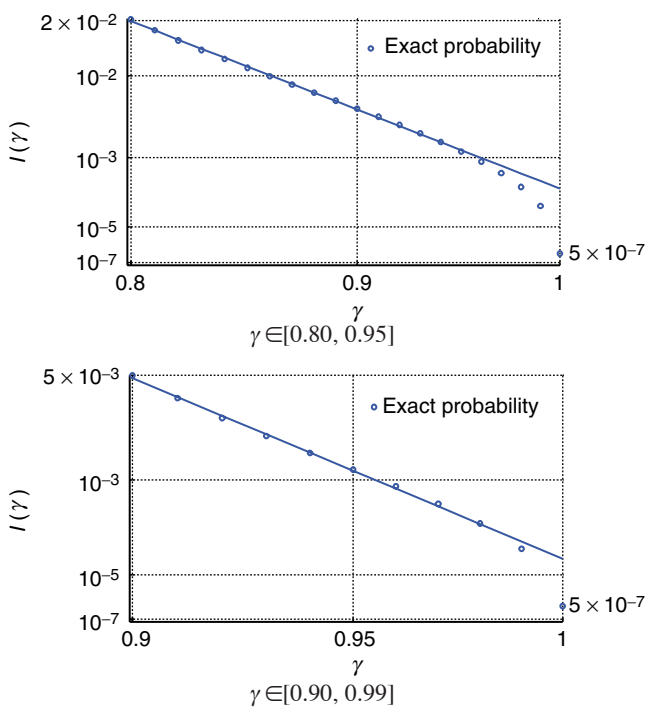

Figure 2. Extrapolation results in the example

(Note that the vertical axes as well as the horizontal axes in the plots are scaled as introduced)

where the symbol “ \approx ” signifies that the function in the left hand side is approximated by the function in the right hand side. In Bucher (2009), $\beta(\eta)$ is related to the probability integral $I(\eta)$ as:

$$I(\eta) = \Phi(-\beta(\eta)) \tag{12}$$

where $\Phi(\bullet)$ is the cumulative distribution function of the standard normal random variable. This approximation is consistent with the asymptotic theory in the following sense:

$$\beta(\eta) \sim A\eta \tag{13}$$

Here, “ \sim ” signifies that $\lim_{\eta \rightarrow \infty} \beta(\eta)/(A\eta) = 1$ holds. It is mentioned in Bucher (2009) that other forms that conform with Eqn 13 are admissible as candidates for the approximating functional form.

In the following, the scheme is applied to the reliability assessment of a simplistic parallel system. Note, however, that since the scheme is originally not proposed for the cases of system reliability assessment, the results from the following example are not meant for the criticism to the scheme. Instead, the purpose of the example is to investigate the limitations of the scheme, and by doing so, it serves as a motivation and basis to develop another scheme, which is applicable for a broader range of reliability assessments.

2.2.2. Critical example

Consider a parallel system whose failure is defined by the domain:

$$D = \left\{ \bigcap_{j=1}^{J_1} -x_j + c \leq 0 \right\} \tag{14}$$

Here, $J_1 = 3$ and $c = 1$ are assumed. The basic random variables $\mathbf{X}_3 = (X_1, X_2, X_3)^T$ are independently identically distributed normal random variables with mean values of 0 and standard deviations of $1/\eta_0$. Consider the scaled probability integral $I(\eta)$, which is expressed as:

$$I(\eta) = \int_D \prod_{j=1}^3 \frac{\eta}{\sqrt{2\pi}} \exp\left(-\frac{\eta^2 x_j^2}{2}\right) d\mathbf{x}_3 = [\Phi(-\eta)]^3 \tag{15}$$

The approximation in Eqn 11 can be adopted directly together with Eqn 12.

In order to investigate the range in which the assumption of the asymptotic characteristics of the probability integral (Eqn 13) is valid, the values of $\beta(\eta)/\eta$ are plotted as a function of η , see Figure 3; if the

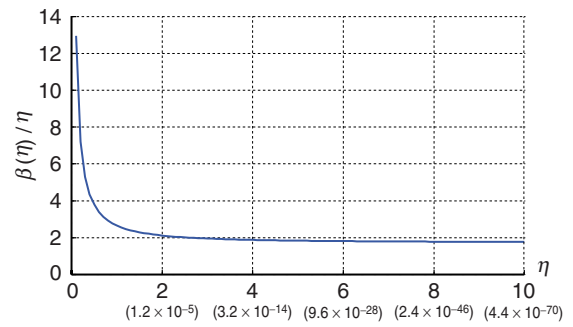

Figure 3. Asymptotic characteristics of the probability integral (The values in the brackets are the corresponding values of $I(\eta)$)

assumption is valid, the values of $\beta(\eta)/\eta$ should be constant with respect to the values of η . The figure shows that the assumption is valid when the value of η is larger than around 4. This implies that, in order for the asymptotic characteristics to be a valid assumption, both the value of η_0 in the original problem and the values of η for curve fitting must be at least larger than 4; however, for $\eta = 4$, $I(\eta) = 3.2 \times 10^{-14}$, which is by far smaller than those of practical interest. Within the range of $I(\eta)$ of practical interest, the asymptotic characteristics is, in this example, not a valid assumption, and the non-asymptotic term (i.e. B/η in Eqn 11) plays an important role in extrapolating the probability integral $I(\eta)$.

Motivated by the successes illustrated in the papers by Naess *et al.* (2009) and Bucher (2009), and by the limitations presented above, another scheme is presented in the following, which can be applied for the cases of both parallel and series systems as well as for the cases where the assumption of the asymptotic characteristics may not be valid.

2.3. General Concept of Probability Integral Solution by Extrapolation

The approach proposed in the papers by Naess *et al.* (2009) and Bucher (2009) may be stated in a slightly generalized form as follows: Consider a scalable parametric representation of the probability integral $I(\lambda)$ where the scalar λ is the scaling factor so that for a certain value λ_0 of λ the probability integral $I(\lambda_0)$ corresponds to the probability integral of interest. Assume a functional form $f(\lambda|\mathbf{q})$ characterized by parameters \mathbf{q} , which approximates the probability integrals $I(\lambda)$, i.e. $I(\lambda) \approx f(\lambda|\mathbf{q})$. Then, estimate the parameters \mathbf{q} by using the estimated values $I(\lambda)$ of the probability integrals by (crude) Monte Carlo simulations for several values of λ that correspond to relatively high probabilities. Substituting the estimated parameters $\hat{\mathbf{q}}$ into the functional form $f(\lambda|\mathbf{q})$, the

probability integral $I(\lambda_0)$ of interest is obtained by extrapolation as $I(\lambda_0) = f(\lambda_0 | \hat{\mathbf{q}})$.

Within the general concept of the probability integral solution by extrapolation outlined above, it is to be noted that the main contribution of the present paper is to propose such a scalable parametric representation, i.e. $I(\lambda)$ with a functional form $f(\lambda | \mathbf{q})$ suitable for the extrapolation.

3. PROPOSED SCHEME FOR PROBABILITY INTEGRAL PARAMETERIZATION

3.1. Scalable Representation of Probability Integrals

A series of papers (Breitung 1984; Breitung and Hohenbichler 1989; Hohenbichler *et al.* 1987) consider, in the context of the evaluation of the probability of failure of systems, multi-normal probability integrals $I(\lambda)$ whose integral domain is characterized by a scaling factor λ as:

$$I(\lambda) = \int_{D(\lambda)} \phi_n(\mathbf{u}_n) d\mathbf{u}_n \quad (16)$$

where $\phi_n(\mathbf{u}_n)$ is the joint probability density function of the standard normal variables $\mathbf{U}_n = (U_1, U_2, \dots, U_n)^T$, and the domain $D(\lambda)$ is the domain of D scaled by the real-valued positive parameter λ with respect to the origin, see Figure 4.

It is pointed out in the papers (Breitung 1984; Breitung and Hohenbichler 1989; Hohenbichler *et al.* 1987) that the integral above is reduced to the following form of integral:

$$I(\lambda) = \int_D \phi_n(\lambda \mathbf{u}_n) d\mathbf{u}_n = \lambda^n \int_D \frac{1}{(2\pi)^{n/2}} \exp\left(-\frac{\lambda^2}{2} |\mathbf{u}_n|^2\right) d\mathbf{u}_n \quad (17)$$

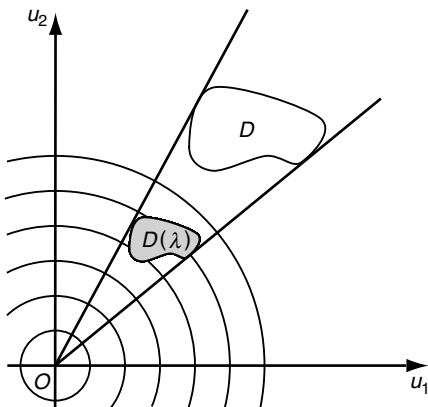

Figure 4. Parametric representation of failure domain by a scaling factor

The integral form in the last equation is a special case of the so-called Laplace-type integral, to which asymptotic approximations have been extensively investigated, see e.g. Bleistein and Handelsman (1975) for the definition of the Laplace-type integral as well as its asymptotic characteristics.

The domain D can be generally given in the form of Eqn 2, and the scaled domain $D(\lambda)$ is written as:

$$D(\lambda) = \left\{ \bigcup_{m=1}^M \bigcap_{j=1}^{J_m} g_{mj}(\mathbf{u}_n / \lambda) < 0 \right\} \quad (18)$$

The present paper employs this scalable parametric representation of the integral domain as the basis for the extrapolation; the domain D is chosen so that for a certain value λ_0 of λ the scaled domain $D(\lambda_0)$ corresponds to the domain of interest.

It should be realized that the scaling factor λ introduced as above plays the role equivalent to the scaling factor η introduced in section 2.2 in regard to the scaling of the probability integral.

Note that in sections 3.2 and 3.3, the random variables are assumed to be independent standard normal variables. General cases where the random variables are not standard normal are considered in section 3.4.

3.2. Functional Form for the Extrapolation in Asymptotic Case

3.2.1. Derivation of the functional form

It is assumed here that the probability integral $I(\lambda)$ has a single design point on the boundary of the integral domain $D(\lambda)$. The applicability of the scheme presented in this section for other cases with two or more design points is discussed in section 5.3 together with the results in the examples in section 4. Applying the Theorem 1 in Breitung and Hohenbichler (1989), under several conditions (see Breitung and Hohenbichler 1989), the following asymptotic approximation form is obtained as $\lambda \rightarrow \infty$:

$$I(\lambda) \sim (2\pi)^{-k/2} |\det(\mathbf{A})|^{-1} \left(\prod_{i=1}^k |\gamma_i|^{-1} \right) \times |\det(\mathbf{B})|^{-1/2} \lambda^{-k} \exp\left(-\frac{\lambda^2}{2} |\mathbf{u}_n^*|^2\right) \quad (19)$$

Here, $|\mathbf{u}_n^*|$ is the distance from the origin to the design point \mathbf{u}_n^* , i.e. $|\mathbf{u}_n^*| = \min_{\mathbf{u}_n \in D} |\mathbf{u}_n|$; k is the number of “active” limit state functions, i.e. the number of the limit state functions whose values are equal to zero at the

design point \mathbf{u}_n^* ; $\det(\bullet)$ represents the determinant of a matrix. Without going into detail, it is said that $|\det(\mathbf{A})|$, $|\det(\mathbf{B})|$, and γ_i ($i = 1, 2, \dots, k$) concern the geometric property of the limit state functions at the design point; i.e. given the limit state functions, the values of these parameters are uniquely determined.

Since there exists a set of positive real numbers c_i ($i = 1, 2, \dots, k$) such that $\sum_{i=1}^k c_i^2 = |\mathbf{u}_n^*|^2$ holds, using these numbers, it is possible to write Eqn 19 as:

$$I(\lambda) \sim |\det(\mathbf{A})|^{-1} |\det(\mathbf{B})|^{-1/2} \left[\prod_{i=1}^k c_i^{-1} |\gamma_i|^{-1} \right] \times \left[\prod_{i=1}^k (2\pi)^{-1/2} (c_i \lambda)^{-1} \exp\left(-\frac{(c_i \lambda)^2}{2}\right) \right] \quad (20)$$

Using the relation $\Phi(-x) \sim (2\pi)^{-1/2} x^{-1} \exp(-x^2/2)$ for $x \rightarrow \infty$, and denoting $a_\infty = |\det(\mathbf{A})|^{-1} |\det(\mathbf{B})|^{-1/2} \times \left[\prod_{i=1}^k c_i^{-1} |\gamma_i|^{-1} \right]$, Eqn 20 is written as (see also Nishijima et al. 2010):

$$I(\lambda) \sim a_\infty \prod_{i=1}^k \Phi(-c_i \lambda) \quad (21)$$

Note that the right hand sides in Eqns 20 and 21 are asymptotically identical as $\lambda \rightarrow \infty$; however, it is empirically known that Eqn 21 better approximates the probability integral $I(\lambda)$ for larger yet finite value of λ . In the context of SORM, the values of these parameters a_∞ and c_i ($i = 1, 2, \dots, k$) are obtained first by searching for the design point, and then, by computing the curvatures of the limit state functions at the design point; seen in the light of the proposed scheme, these are estimated by curve fitting method using a sequence of the values of scaled probability integrals $I(\lambda)$, which are provided by Monte Carlo simulations. This difference is emphasized with an example in the following.

3.2.2. Illustrative example

Consider the following probability integral:

$$I = \int_{D=\{(u_1, u_2) | u_1^2 - u_2 + 1 \leq 0\}} \phi(u_1) \phi(u_2) du_1 du_2 \quad (22)$$

Here, $\phi(\bullet)$ is the standard normal probability density function. Following the proposed scheme, the scaled probability integral $I(\lambda)$ is given as:

$$I(\lambda) = \int_{D(\lambda)} \phi(u_1) \phi(u_2) du_1 du_2 \quad (23)$$

where the scaled integral domain $D(\lambda)$ is defined as:

$$D(\lambda) = \left\{ (u_1, u_2) \mid \left(\frac{u_1}{\lambda}\right)^2 - \frac{u_2}{\lambda} + 1 \leq 0 \right\} \quad (24)$$

The scaled integral domain is shown in Figure 5.

For the purpose of comparison, the values of the scaled probability integrals are first computed by means of Monte Carlo simulations. This is shown in Figure 6 (indicated with ‘‘Exact’’). Furthermore, it is known from the asymptotic theory in the context of SORM that:

$$I(\lambda) \sim \tilde{a}_\infty \Phi(-\tilde{c}_1 \lambda) \quad (25)$$

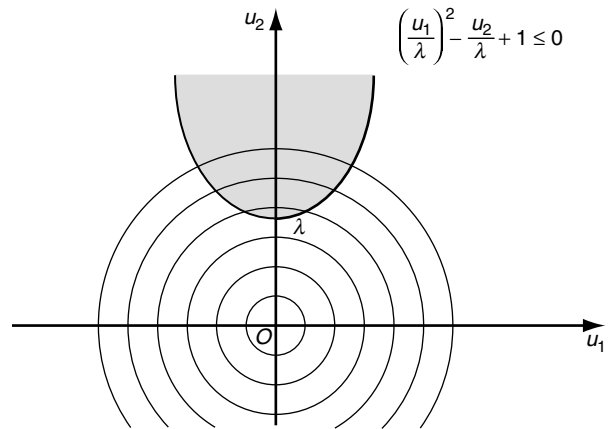

Figure 5. The scaled integral domain in the illustrative example

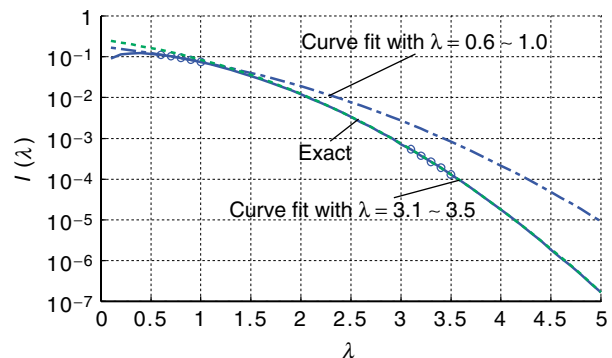

Figure 6. Scaled probability integrals as a function of λ (The circles in the figure represent the points for curve fitting; same for the following figures for the numerical results. Note that the curves ‘‘Exact’’ and ‘‘Curve fit with $\lambda = 3.1\sim 3.5$ ’’ are overlapped in the interval $\lambda \in [2, 5]$)

where $\tilde{a}_\infty = (1 + \tilde{c}_1 \tilde{\alpha}_1)^{-1/2}$, \tilde{c}_1 is the distance from the origin to the design point in the integral domain D , and $\tilde{\alpha}_1$ is the principal curvature of the original limit state function at the design point, which in this case is calculated as: $\tilde{\alpha}_1 = (\partial^2 u_2 / \partial u_1^2) |_{(u_1, u_2)=(0,1)} = 2$, where $u_2 = u_1^2 + 1$. Thus, $\tilde{c}_1 = 1$ and $\tilde{a}_\infty = 0.577$. Note that $k = 1$ for this example since only one limit state function is involved in the definition of the integral domain.

The parameters in Eqn 21 are estimated by a standard curve fitting method first with the points of $\lambda = 3.1, 3.2, 3.3, 3.4, 3.5$. The values of the parameters estimated are: $\hat{a}_\infty = 0.5322$ and $\hat{c}_1 = 0.9965$. The extrapolation result with the values of the estimated parameter is shown in Figure 6 (indicated with ‘‘Curve fit with $\lambda = 3.1 \sim 3.5$ ’’). Besides the performance of the extrapolation, it should be emphasized that the estimated values of the parameters, especially \hat{c}_1 , which is more relevant, are very close to those values calculated based on the asymptotic theory. Note that these values are calculated without identifying the location of the design point and calculating the curvature of the limit state function at the design point; instead, only by means of the curve fitting. In this sense, it can be said that the information of the location of the design point is not required for assessing the system reliability, and the functional form of the extrapolation in Eqn 21 can be seen as a meta-level representation of asymptotic characteristics of the system reliability.

Then, the parameters in Eqn 21 are estimated with the points of $\lambda = 0.6, 0.7, 0.8, 0.9, 1.0$ instead of $\lambda = 3.1, 3.2, 3.3, 3.4, 3.5$ (indicated with ‘‘Curve fit with $\lambda = 0.6 \sim 1.0$ ’’ in Figure 6). In contrast to the case above, the extrapolation with the functional form with the estimated values of the parameters ($\hat{a}_\infty = 0.3601$, $\tilde{c}_1 = 0.81$) fail. The reason for this can be that the functional form utilized for the extrapolation is not appropriate for relatively small values of λ . Mathematically, Eqn 21 is correct only asymptotically, i.e. as $\lambda \rightarrow \infty$; practically, it is said that the values of λ should be ‘‘sufficiently’’ large. However, in general the values to be considered sufficiently large depend on the probability integrals in consideration, and cannot be known a-priori. Thus, the result from this example necessitates the extension of Eqn 21 to the non-asymptotic case such that the extended form is valid for a broader range of the value of λ .

3.3. Extension to Non-Asymptotic Form

The functional form presented in the previous section takes basis in the asymptotic characteristics of the integral $I(\lambda)$. It is, however, in general not known if and to which degree the assumption of the asymptotic characteristics is valid for the integral domains of

interest, as is shown in the previous section. Thus, a functional form of the extrapolation is required which can be applied for a broader range of the scaling factor λ , beyond the range where the asymptotic characteristics is valid. For this purpose, the functional form presented in the previous section is extended.

Consider the integral $I(\lambda)$ defined by Eqn 16. With a rotational transformation of the integral domain, it is possible that the integral $I(\lambda)$ is expressed as:

$$I(\lambda) = \int_{D^*(\lambda)} \phi_n(\mathbf{u}_n) d\mathbf{u}_n \tag{26}$$

where the design point of the transformed integral domain $D^*(\lambda)$ is $(\lambda c_1^*, \dots, \lambda c_k^*, 0, \dots, 0)$ satisfying $\sum_{i=1}^k c_i^2 = |\mathbf{u}_n^*|^2$ and $c_i > 0$ ($i = 1, \dots, k$), see Figure 7 (left). Define an integral $J(\lambda)$ as:

$$J(\lambda) = \int_{\tilde{D}^*(\lambda)} \phi_n(\mathbf{u}_n) d\mathbf{u}_n \tag{27}$$

where the integral domain $\tilde{D}^*(\lambda)$ is given as:

$$\tilde{D}^*(\lambda) = \left\{ (u_1, \dots, u_n) \mid \prod_{i=1}^k \lambda c_i^* < u_i \right\} \tag{28}$$

That is, the two integral domains share the same design point $(\lambda c_1^*, \dots, \lambda c_k^*, 0, \dots, 0)$, see Figure 7 (right).

Further, it should be realized that the integral $J(\lambda)$ is written as:

$$J(\lambda) = \int_{-\infty}^{\infty} \dots \int_{-\infty}^{\infty} \int_{\lambda c_k^*}^{\infty} \int_{\lambda c_{k-1}^*}^{\infty} \dots \int_{\lambda c_1^*}^{\infty} \phi_n(\mathbf{u}_n) d\mathbf{u}_n = \prod_{i=1}^k \Phi(-c_i^* \lambda) \tag{29}$$

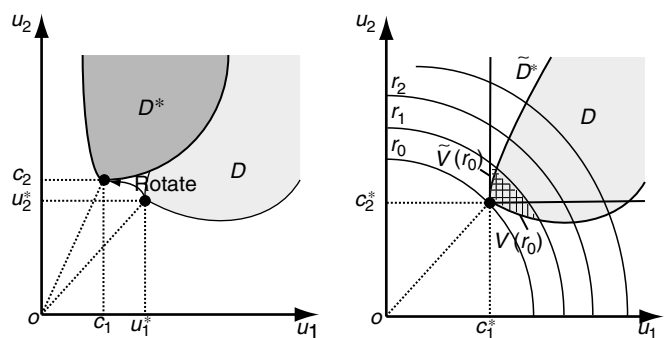

Figure 7. Rotation of the integral domain in the standard space (left) and the domains D and \tilde{D}^* (right)

Denote by $a(\lambda)$ the ratio between the two integrals $I(\lambda)$ and $J(\lambda)$ as: $a(\lambda) = I(\lambda)/J(\lambda)$. From the definition of the ratio $a(\lambda)$, it follows:

$$I(\lambda) = a(\lambda)J(\lambda) = a(\lambda) \prod_{i=1}^k \Phi(-c_i^* \lambda) \quad (30)$$

Thus, the introduction of the ratio $a(\lambda)$ can be seen as an extension of Eqn 21. Note that Eqn 30 is not an approximation but is an identity. In what follows, the approximation of the functional form of the ratio $a(\lambda)$ is investigated, which does not depend on the asymptotic characteristics of the integral $I(\lambda)$. The ratio $a(\lambda)$ can be reformulated and approximated as follows:

$$\begin{aligned} a(\lambda) &= \frac{\int_{\lambda D^*} \phi_n(\mathbf{u}_n) d\mathbf{u}_n}{\int_{\lambda \tilde{D}^*} \phi_n(\mathbf{u}_n) d\mathbf{u}_n} = \frac{\lambda^n \int_D \phi_n(\lambda \mathbf{u}_n) d\mathbf{u}_n}{\lambda^n \int_{\tilde{D}} \phi_n(\lambda \mathbf{u}_n) d\mathbf{u}_n} \\ &= \frac{\int_D \exp(-\lambda^2 |\mathbf{u}_n|^2 / 2) d\mathbf{u}_n}{\int_{\tilde{D}} \exp(-\lambda^2 |\mathbf{u}_n|^2 / 2) d\mathbf{u}_n} \\ &\approx \frac{\sum_{l=0}^{\infty} \exp(-\lambda^2 r_l^2 / 2) V(r_l)}{\sum_{l=0}^{\infty} \exp(-\lambda^2 r_l^2 / 2) \tilde{V}(r_l)} \\ &= \frac{\exp(-\lambda^2 r_0^2 / 2) \left[V(r_0) + \sum_{l=1}^{\infty} \exp(-\lambda^2 (r_l^2 - r_0^2) / 2) V(r_l) \right]}{\exp(-\lambda^2 r_0^2 / 2) \left[\tilde{V}(r_0) + \sum_{l=1}^{\infty} \exp(-\lambda^2 (r_l^2 - r_0^2) / 2) \tilde{V}(r_l) \right]} \quad (31) \\ &= \frac{V(r_0) + \sum_{l=1}^{\infty} \exp(-\lambda^2 (r_l^2 - r_0^2) / 2) V(r_l)}{\tilde{V}(r_0) + \sum_{l=1}^{\infty} \exp(-\lambda^2 (r_l^2 - r_0^2) / 2) \tilde{V}(r_l)} \\ &= \frac{V(r_0) + \sum_{l=1}^{\infty} \exp(-\lambda^2 R_l) V(r_l)}{\tilde{V}(r_0) + \sum_{l=1}^{\infty} \exp(-\lambda^2 R_l) \tilde{V}(r_l)} \end{aligned}$$

Here, for the discretization in the second line, it is utilized that the integrands in the last term of the first line are only functions of the distance $|\mathbf{u}_n|$ from the origin: $\{r_l\}_{l=0}^{\infty}$ is the sequence of the distances from the origin at which the integrals are discretized, and $r_0 = |\mathbf{u}_n^*| > 0$, $r_l = r_0 + l \Delta r$, $\Delta r > 0$; $\{V(r_l)\}_{l=0}^{\infty}$ and $\{\tilde{V}(r_l)\}_{l=0}^{\infty}$ are the sequences of the corresponding volumes at the discretized distances, see Figure 7 (right); $R_l = (r_l^2 - r_0^2)/2$, and it can be approximated as: $R_l = ((r_0 + l\Delta r)^2 - r_0^2)/2 \approx l\Delta r$.

As a next step, the approximation of the summations in the last term of Eqn 31 is considered. The values of the terms $V(r_l)$ and $\tilde{V}(r_l)$ grow at most with the polynomial order of $n-1$ with respect to l , whereas the values of the exponents exponentially decrease as a function of l . Thus, the summations in the last term can be approximated by a finite number of terms in the summations. The change rates of a few subsequent terms of $V(r_l)$ and $\tilde{V}(r_l)$ depend on the local geometry of the failure domain. Focusing on the first few terms of $V(r_l)$ and $\tilde{V}(r_l)$, only which are significant to the overall summations in Eqn 31 due to the exponential decrease of the term, $\exp(-\lambda^2 R_l)$. It is assumed that these change rates are approximated by one of the two extreme situations; i.e. $V(r_l)$ and/or $\tilde{V}(r_l)$ (1) are constant or (2) increase/decrease quasi-exponentially (they grow/decay fast and the rate of growth/decay is close to exponential increase/decrease at least for the first few terms). In both cases, $V(r_l)$ can be represented as: $V(r_l) \approx zw^l (z > 0, w > 0)$ with certain parameters z and w . Assuming the same situations for $\tilde{V}(r_l)$ and substituting these approximations into the last term of Eqn 31, it is found that the ratio $a(\lambda)$ may be approximated in the form of (see also Nishijima et al. 2010):

$$a(\lambda) \approx a_{\infty} \frac{1 - b_1 \exp(-b_2 \lambda^2)}{1 - b_3 \exp(-b_4 \lambda^2)} \quad (32)$$

where the parameters $a_{\infty}, b_1, b_2, b_3, b_4$ are positive. Note that $a(\lambda) \rightarrow a_{\infty}$ (as $\lambda \rightarrow \infty$), which is reduced to the asymptotic functional form of the probability integral in the previous section.

To obtain the probability integral of interest by the fitting and the extrapolation correctly, the proposed formulation of $a(\lambda)$ in Eqn 32 should, at least, have no discontinuity points in the extrapolation and should always be positive. In practice, it may happen that $(1 - b_1 \exp(-b_2 \lambda^2)) / (1 - b_3 \exp(-b_4 \lambda^2))$ becomes negative or the denominator $(1 - b_3 \exp(-b_4 \lambda^2))$ is equal to zero in the extrapolation; for example, assume that the range of λ for curve fitting is $\lambda_1 \leq \lambda \leq \lambda_p$, and the estimated values of the parameters in Eqn 32, b_1, b_2, b_3 , and b_4 , are $\hat{b}_1, \hat{b}_2, \hat{b}_3$, and \hat{b}_4 respectively. If both $\ln \hat{b}_3 < 0$ and $\ln \hat{b}_1 / \hat{b}_2 > \lambda_p^2$ are satisfied, it is easy to prove that $(1 - b_1 \exp(-b_2 \lambda^2)) / (1 - b_3 \exp(-b_4 \lambda^2))$ will be less than zero in the range of $\lambda > \sqrt{\ln \hat{b}_1 / \hat{b}_2}$. On the other hand, if $\ln \hat{b}_3 / \hat{b}_4 > \lambda_p^2$, the zero-value of $1 - b_3 \exp(-b_4 \lambda^2)$ will appear at the point $\lambda = \sqrt{\ln \hat{b}_3 / \hat{b}_4}$ in the range of extrapolation and it is thus a point of discontinuity of the functional form. To circumvent this problem, the parameter b_1 and b_3 may be replaced by $\exp(-b_1')$ and $\exp(-b_3')$ respectively.

Finally, the proposed functional form for the extrapolation in the non-asymptotic (general) case is represented as:

$$f(\lambda | \mathbf{q}) = a_\infty \frac{1 - \exp(-b_1' \lambda) \exp(-b_2 \lambda^2)}{1 - \exp(-b_3' \lambda) \exp(-b_4 \lambda^2)} \prod_{i=1}^k \Phi(-c_i \lambda) \tag{33}$$

$$= a_\infty \frac{1 - \exp(-b_1' - b_2 \lambda^2)}{1 - \exp(-b_3' - b_4 \lambda^2)} \prod_{i=1}^k \Phi(-c_i \lambda)$$

where $\mathbf{q} = (a_\infty, b_1', b_2, b_3', b_4, c_1, \dots, c_k)$. All the parameters are positive. Without loss of generality, it is assumed that $c_1 \geq c_2 \geq \dots \geq c_k$. It is not difficult to prove that $(1 - \exp(-b_1' - b_2 \lambda^2)) / (1 - \exp(-b_3' - b_4 \lambda^2))$ will be always larger than zero and the requirement that both b_1 and b_3 in Eqn 32 are positive is also satisfied. Note here that the number k of the active limit state functions is generally not known a-priori; however, k is equal to or smaller than $\min \left(n, \max_{m=1, \dots, M} J_m \right)$, see Eqns 1 and 2 for the definitions of n , M , and J_m . The choice of the parameter k in practical applications is discussed in section 5.2.

3.4. Extension to Non-Normal Cases

Consider the probability integral in Eqn 1, where the basic random variables \mathbf{X}_n may not be independent standard normal random variables. Denote by T a transformation $\mathbf{U}_n = T^{-1}(\mathbf{X}_n)$ which transforms the basic random variables \mathbf{X}_n into the independent standard normal random variables \mathbf{U}_n . Such transformations are readily available; e.g. Rosenblatt transformation (e.g. Hohenbichler and Rackwitz 1981), Nataf transformation (e.g. Liu and Der Kiureghian 1986) and moment-based transformation (e.g. Winterstein and Bjerager 1987).

Employing a transformation T , the probability integral in Eqn 1 can be rewritten as:

$$I = \int_{D_U} \phi_n(\mathbf{u}_n) d\mathbf{u}_n \tag{34}$$

where the integral domain D_U is given as:

$$D_U = \left\{ \bigcup_{m=1}^M \bigcap_{j=1}^{J_m} g_{mj}(T(\mathbf{u}_n)) < 0 \right\} \tag{35}$$

The scheme presented in the previous section can be straightforwardly applied as:

$$I(\lambda) = \int_{D_U(\lambda)} \phi_n(\mathbf{u}_n) d\mathbf{u}_n \tag{36}$$

where the scaled integral domain $D_U(\lambda)$ is given as follows:

$$D_U(\lambda) = \left\{ \bigcup_{m=1}^M \bigcap_{j=1}^{J_m} g_{mj}(T(\mathbf{u}_n / \lambda)) < 0 \right\} \tag{37}$$

That is, whenever the basic random variables \mathbf{X}_n are not normal variables, in order to estimate the probability integrals $I(\lambda)$ by Monte Carlo sampling, it is required first to generate realizations from the standard normal distribution, then to scale the realizations by the scaling factor λ , and finally to apply the transformation T .

3.5. Implementation into Programming Code

The general procedure for the evaluation of probability integrals by extrapolation can be stated as follows:

Step 1: Choose a value λ_1 of the scaling factor λ that corresponds to a relatively high probability $I(\lambda_1)$.

Step 2: Generate realizations of the set of the random variables \mathbf{U}_n , i.e. $\mathbf{u}_n^{(1)}, \mathbf{u}_n^{(2)}, \dots, \mathbf{u}_n^{(N)}$. Here, N is the number of the realizations.

Step 3: Calculate $T(\mathbf{u}^{(1)}/\lambda_1), T(\mathbf{u}^{(2)}/\lambda_1), \dots, T(\mathbf{u}^{(N)}/\lambda_1)$.

Step 4: Evaluate $\hat{I}(\lambda_1) = \frac{1}{N} \sum_{l=1}^N I \left[\bigcup_{m=1}^M \bigcap_{j=1}^{J_m} g_{mj} \left(T \left(\mathbf{u}_n^{(l)} / \lambda_1 \right) \right) < 0 \right]$.

Here, $I[\bullet]$ is the indicator function which returns 1 if the condition in the bracket is satisfied; otherwise it returns 0.

Step 5: Repeat Step 1 to Step 4 for different values of the scaling factor λ ; the dataset $(\lambda_p, \hat{I}(\lambda_p)), p = 1, 2, \dots, n_p$ is obtained.

Step 6: Estimate the parameters \mathbf{q} of the functional form $f(\lambda | \mathbf{q})$ in Eqn 21 or Eqn 33 using the dataset obtained in Step 5.

Step 7: Evaluate the probability integral of interest by extrapolation as $I = I(1) \approx f(1 | \hat{\mathbf{q}})$ where $\hat{\mathbf{q}}$ are the parameters estimated in Step 6.

Note that in Step 1 trial-and-errors may be required in order to identify the value of λ that corresponds to relatively high probability $I(\lambda)$. In Step 5, several methods are available for estimating the parameters \mathbf{q} , e.g. non-linear least square methods and Bayesian regression methods. It should be mentioned that the programming code for the parameter estimation is independent from the steps until Step 4; that is, once the programming code is established it can be utilized for different applications. Finally, it is recommended that this procedure is repeated using several datasets consisting of different ranges of the

scaling factor λ in order to examine that the probability integrals obtained by the extrapolations are stable.

Before investigating the performance of the proposed scheme with examples, it should be mentioned here that the presence of the nonlinearity in the limit state functions is not an additional difficulty in applying the presented scheme, compare to FORM (or SORM) or the ordinary Monte Carlo simulations. This is because the scaled failure domains are equivalent to the original failure domains in the sense that these still define the same failure events only with different augments of the limit state functions; one with the original basic random variables (\mathbf{U}_n), and the other with the scaled variables (\mathbf{U}_n/λ) (see Eqn 18). The difference appears only in the likelihood of the failure events, due to the scaling of the failure domains. These can be also seen in Step 4 above, where the original limit state functions are evaluated with realizations of the scaled random variables.

4. EXAMPLES

In this section, several examples are investigated to compare the performances of the three schemes as introduced and presented in the foregoing. The orders of magnitudes of the probabilities evaluated by the extrapolation vary in the range from 10^{-5} to 10^{-9} , whereas the ranges of the probabilities with which the parameters of the functional forms are estimated are fixed as $[10^{-2}, 10^{-3}]$; thus, the performances are investigated with different degrees of the extrapolation.

In these examples, the values of the scaled/shifted probability integrals are estimated by means of crude Monte Carlo simulations with 10^6 samples for each, which is sufficient enough to guarantee that the statistical errors associated with the evaluations of the probability integrals are negligible. The parameters \mathbf{q} are estimated with the transformed dataset of $(\lambda_p, \ln I(\lambda_p))$ for the proposed functional forms, $(\eta_p, \beta(\eta_p)/\eta_p)$ for the functional form proposed by Bucher (2009), and $(\gamma_p, \ln I(\gamma_p))$ for the functional form proposed by Naess *et al.* (2009). Since the scaling factor η in the scheme proposed by Bucher (see section 3.1) play the role equivalent to the scaling factor λ in the proposed scheme, for convenience the scaling factor η is symbolized by λ in the following. However, the scaling factor γ is not equivalent to η and λ , and the dataset of λ_p and may have different values with λ_p . In the parameter estimations, a standard non-linear least squares method (i.e. the function `lsqcurvefit` in MATLAB®) is utilized. The initial values of the parameters are set equal to 0.8 for the examples presented.

In the following sections, a selection of representative examples and their results are shown and discussed. Discussion on these numerical results is provided in section 5.1.

4.1. Critical Example from Section 2.1.2

The critical example in section 2.1.2 is reconsidered. In this example, the procedure for the application of the proposed scheme for the case of non-normal random variables is illustrated step-by-step.

The probability integral I in Eqn 7 can be transformed into the probability integral in the standard normal space (u_R, u_S) as:

$$I = \int_{\{F_R^{-1}(\Phi(u_R)) - F_S^{-1}(\Phi(u_S)) < 0\}} \phi(u_R)\phi(u_S) du_R du_S \quad (38)$$

where $F_R(r)$ and $F_S(s)$ respectively are the cumulative distribution functions of the random variables R and S . These are written as:

$$F_R(r) = \begin{cases} 0 & (r \leq 0.99) \\ r - 0.99 & (0.99 < r \leq 1.99) \\ 1 & (r > 1.99) \end{cases} \quad (39)$$

$$F_S(s) = \begin{cases} 0 & (s \leq 0) \\ s & (0 < s \leq 1) \\ 1 & (s > 1) \end{cases} \quad (40)$$

Therefore, Eqn 7 can be rewritten as:

$$I = \int_{\{\Phi(u_R) + 0.99 - \Phi(u_S) < 0\}} \phi(u_R)\phi(u_S) du_R du_S \quad (41)$$

Thus, the scaled probability integral $I(\lambda)$ is formulated as:

$$I(\lambda) = \int_{\{\Phi(u_R/\lambda) + 0.99 - \Phi(u_S/\lambda) < 0\}} \phi(u_R)\phi(u_S) du_R du_S \quad (42)$$

and $I = I(1)$, see also Figure 8.

The parameters in the functional form proposed by Naess *et al.* (2009) are estimated using the points in the range $\gamma \in [0.86, 0.95]$, and the range for other two forms are $\lambda \in [0.42, 0.58]$. The integrals in the ranges are computed by means of Monte Carlo simulations. Here, $k = 1$ since the integral domain involves only one limit state function. The result is shown in Figure 9.

Note that Eqns 41 and 42 shown above are only for the illustrative purpose. In practice, the explicit transformation of the domain is not required; instead, the procedure written in section 3.5 should be followed.

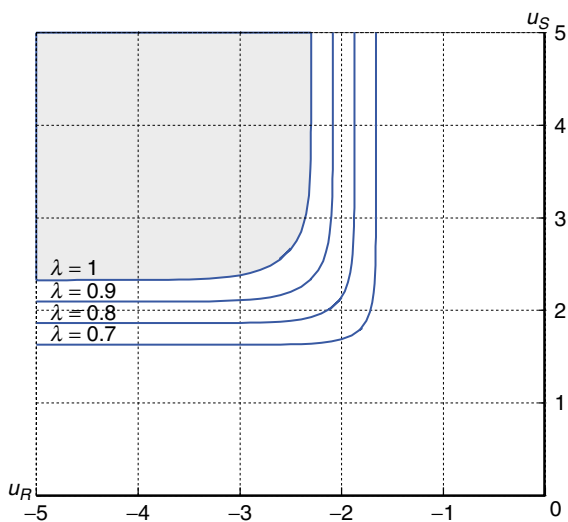

Figure 8. Scaled integral domains for some values of λ in the standard normal space

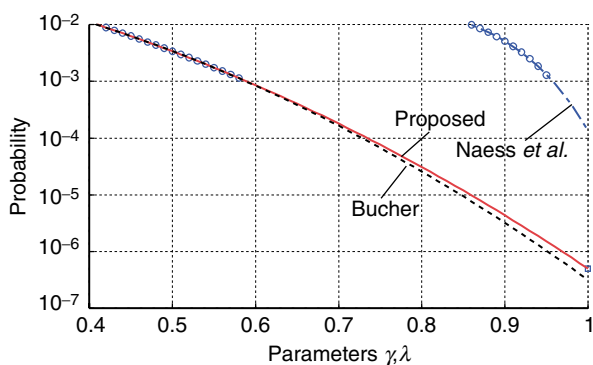

Figure 9. Extrapolation results in the critical example in section 2.1.2 (The square in the figure represents the exact value; same for the following figures for the extrapolation results)

4.2. Critical Example from Section 2.2.2

The critical example shown in section 2.2.2 is considered in the case of $c = 3$ and $\eta_0 = 1$. The result is shown in Figure 10. Here, $k = J_1 = 3$ since there are $J_1 (= 3)$ limit state functions whose values are equal to zero at the design point (c, c, c) . The detailed discussion about the choice of k in the case that the “active” limit state functions is generally unknown a-priori is given in section 5.2.

4.3. Parallel and Series System Reliability

Consider the probability integral in the following form:

$$I = \int_{D_i} \phi(u_1)\phi(u_2)du_1du_2 \quad (43)$$

where the integral domains D_i ($i = 1, 2, 3, 4$) (see also Figure 11 and Figure 12) are:

$$\text{Example 1: } D_1 = \left\{ (u_1, u_2) \mid u_1 > \frac{5}{\sqrt{2}} \cap u_2 > \frac{5}{\sqrt{2}} \right\} \quad (44)$$

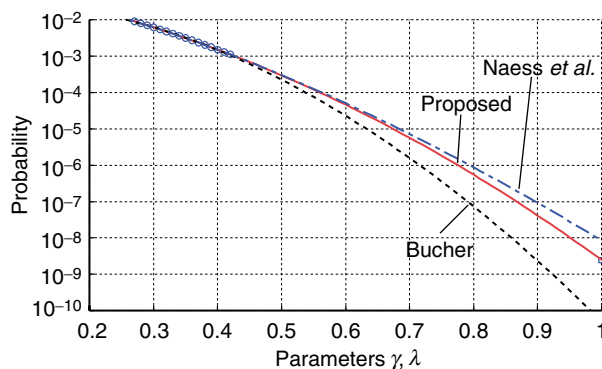

Figure 10. Extrapolation results in the critical example in section 2.2.2 ($c = 3$ and $\eta_0 = 1$)

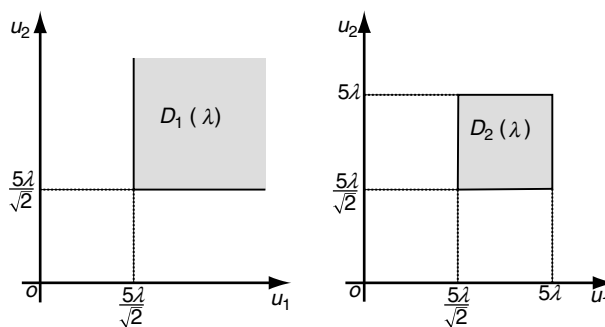

Figure 11. Principal examples of parallel system: Example 1 (left) and Example 2 (right)

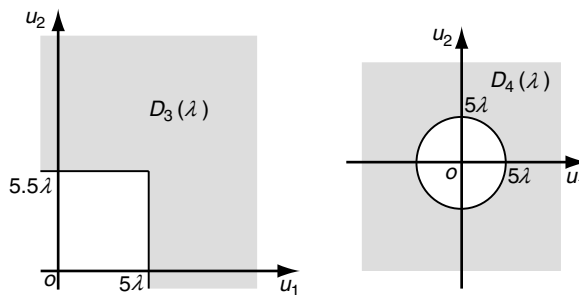

Figure 12. Principal examples of series system: Example 3 (left) and Example 4 (right)

$$\text{Example 2: } D_2 = \left\{ (u_1, u_2) \mid \frac{5}{\sqrt{2}} < u_1 \leq 5 \cap \frac{5}{\sqrt{2}} < u_2 \leq 5 \right\} \quad (45)$$

$$\text{Example 3: } D_3 = \left\{ (u_1, u_2) \mid u_1 > 5 \cup u_2 > 5.5 \right\} \quad (46)$$

$$\text{Example 4: } D_4 = \left\{ (u_1, u_2) \mid u_1^2 + u_2^2 > 5^2 \right\} \quad (47)$$

The probability integrals with the first two integral domains correspond to the reliability analyses of parallel systems, whereas the probability integrals with

the last two domains correspond to the reliability analyses of series systems. Here, note that the integral domain D_4 is considered as a special case of series system where the design points of all (infinite number of) the limit state functions are located at the same distance to the origin. The numerical results are shown in Figure 13.

4.4. Practical Examples

4.4.1. Daniels system

The Daniels system is considered as a typical example of parallel systems in practice, which is taken from Song and Der Kiureghian (2003), see also Figure 14. There are totally six ideally brittle wires in the system. The strengths X_i ($i = 1, 2, \dots, 6$) of the six wires are assumed to identically and independently follow the Weibull distribution:

$$F_{X_i}(x) = 1 - \exp(-0.01x^{10}) \quad (x > 0) \quad (48)$$

The load P is assumed to be deterministic, equal to 4.5, and uniformly distributed to the wires. If some of the wires fail, the load is uniformly redistributed over the surviving wires. The failure of the system is defined as the event that all the six wires fail. The numerical result is shown in Figure 15.

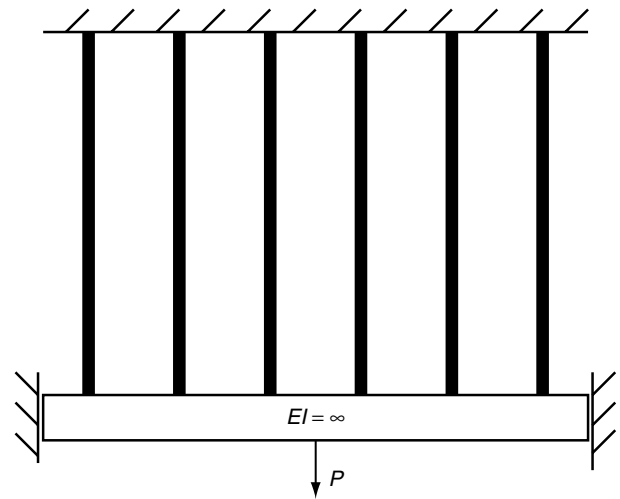

Figure 14. Example of Daniels system

4.4.2. Simple truss structure

The truss bridge example investigated in Naess *et al.* (2009) (originally presented in Thoft-Christensen and Murotsu 1986) is considered, see Figure 16. It is assumed that: the yield stress σ_m of each truss member ($m = 1, 2, \dots, 13$) follows the normal distribution; the loads P_1, P_2, P_3 follow the normal distribution also; all these random variables are assumed to be independent to each other; the cross section A_m of each truss member

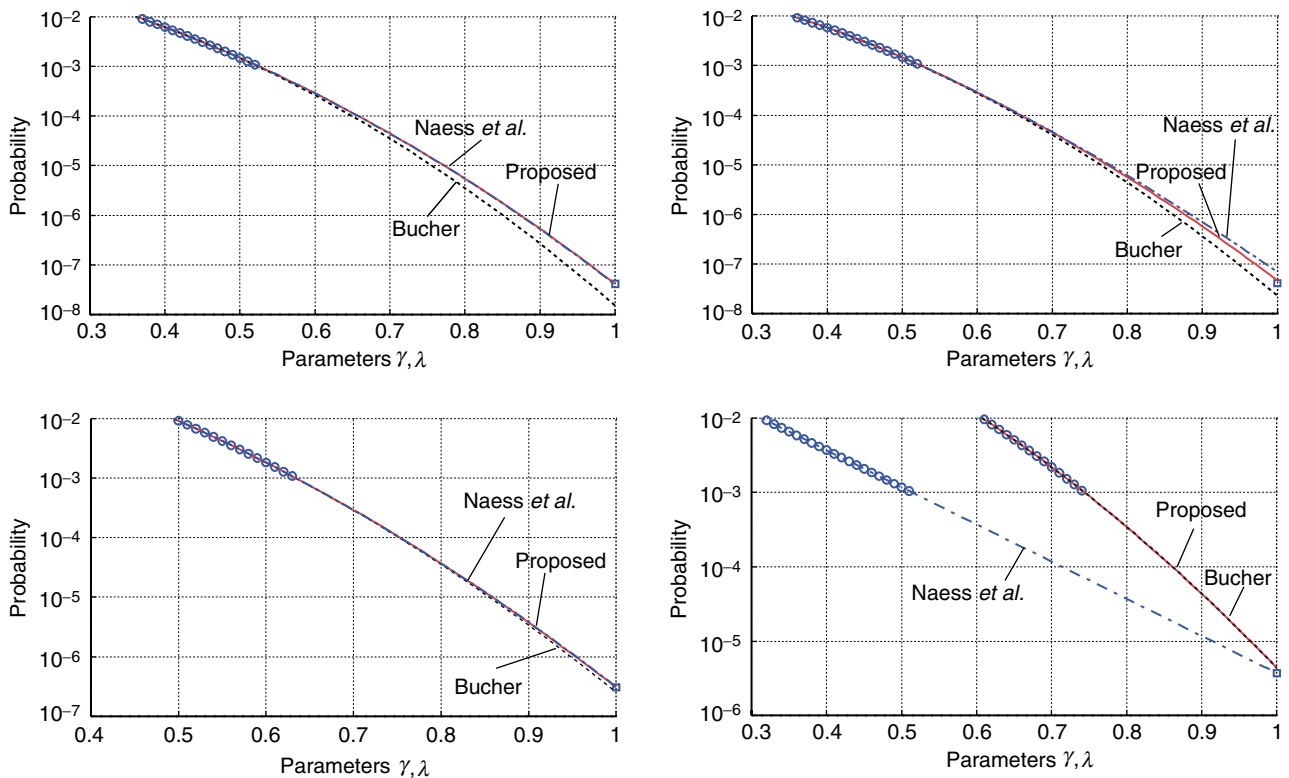

Figure 13. Extrapolation results [Example 1 (left, top), Example 2 (right, top), Example 3 (left, bottom), Example 4 (right, bottom)]

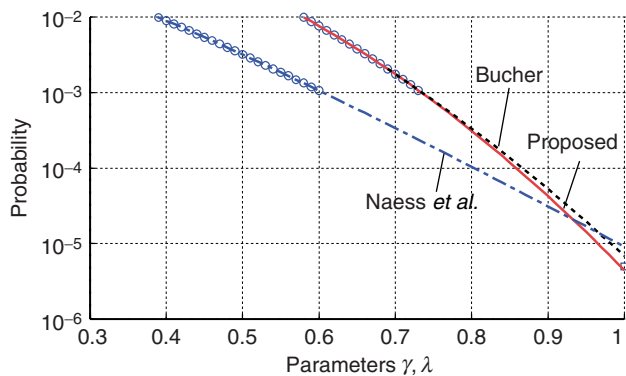

Figure 15. Extrapolation results in the example of Daniels system

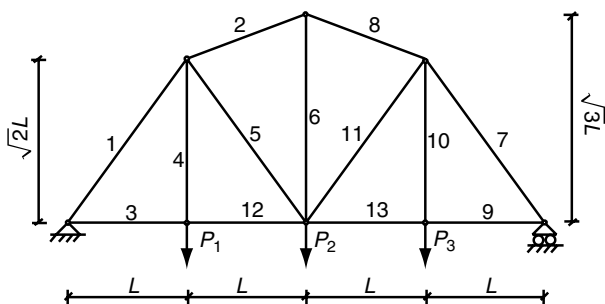

Figure 16. Example of simple truss structure

and the representative length L are deterministic, see Table 1 for the definitions of these random variables and constants. 13 failure modes are considered as the constituents of the series system failure, and the corresponding limit state functions are given as:

$$g_m(\sigma_m, P_1, P_2, P_3) = A_m \sigma_m - (a_{m1} P_1 + a_{m2} P_2 + a_{m3} P_3) \quad (49)$$

Table 1. Variables, constants and coefficients in the example of the simple truss structure ($m = 1, 2, \dots, 13$)

	Probability distribution	Mean value	Coefficient of variation
s_m (MPa)	Normal	275.8	0.15
P_m (kN)	Normal	89	0.15
Deterministic value			
A_m (cm ²)	18.7, 13.1, 11.7, 11.3, 3.3, 8.0, 18.7, 13.1, 11.7, 11.3, 3.3, 11.7, 11.7		
L (m)	2.54		
Coefficient			
a_{m1}	0.9186, 0.3029, 0.5303, 1.0, -0.4186, 0.1835, 0.3062, 0.3029, 0.1768, 1.0, 0.1938, 0.5303, 0.1768		
a_{m2}	0.6124, 0.6058, 0.3535, 0, 0.3876, 0.3670, 0.6124, 0.6058, 0.3535, 0, 0.3876, 0.3536, 0.3536		
a_{m3}	0.3062, 0.3029, 0.1768, 0, 0.1938, 0.1835, 0.9186, 0.3029, 0.5303, 0, 0.4186, 0.1768, 0.5303		

The values of the coefficients a_{m1} , a_{m2} , and a_{m3} are provided in Table 1. The failure domain is written as: $\bigcup_{m=1}^{13} \{g_m(\sigma_m, P_1, P_2, P_3) < 0\}$. The numerical result is illustrated in Figure 17.

4.4.3. Redundant truss structure

The truss structure presented in Thoft-Christensen and Murotsu (1986) is considered, with some changes in the parameters of the structural elements. The geometry of the truss structure is illustrated in Figure 18. The truss structure is subject to a horizontal load P concentrated on the top. Assuming that the elements 1, 2, 5 and 6 are not to fail (i.e. the yield strengths are infinite), two failure modes are considered: In the first mode, the element 3 fails first, the load is redistributed over the surviving elements, then the element 4 fails; in the second mode, the element 4 fails first, the load is redistributed over the surviving elements, then the element 3 fails. The corresponding domain D of failure is written as:

$$D = \left\{ \left[\sigma_3 A_3 < (\sqrt{2} - 1)P \cap \sigma_4 A_4 < \sqrt{2}P \right] \cup \left[\sigma_4 A_4 < (\sqrt{2} - 1)P \cap \sigma_3 A_3 < \sqrt{2}P \right] \right\} \quad (50)$$

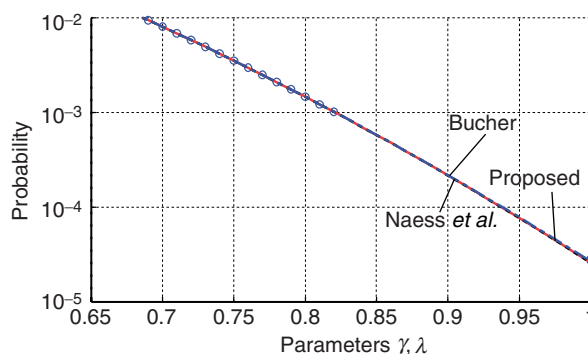

Figure 17. Extrapolation results in the example of the simple truss structure

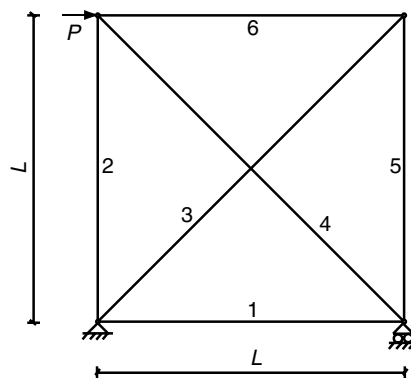

Figure 18. Example of redundant truss structure

Table 2. Random variables and constants in the example of the redundant truss structure

Random variable	Probability distribution	Mean value	Coefficient of variation
σ_3 (MPa)	Normal	300	0.1
σ_4 (MPa)	Normal	300	0.1
P (kN)	Lognormal	250	0.15
Deterministic value			
A_i (m ²)	$A_3 = A_4 = 2 \times 10^{-3}$		

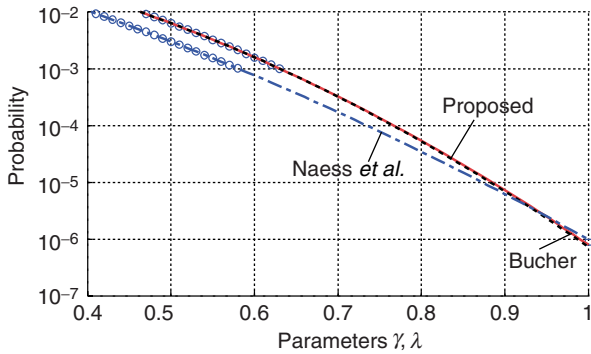

Figure 19. Extrapolation results in the example of the redundant truss structure

where σ_i , A_i ($i = 3, 4$) represent the (random) yielding strength and (deterministic) cross section area of the element i , the properties of which are provided in Table 2. The numerical results are given in Figure 19.

5. DISCUSSIONS

5.1. Performances of the Three Schemes in the Examples

The values of the probability integrals obtained by the three schemes as well as the exact values in the examples in the previous section are presented in Table 3. As shown in the table, the proposed scheme works well for all the examples. The evaluated probabilities by the proposed scheme are generally associated with very small errors as compared to the corresponding “exact” values. The “exact” values are either theoretical solutions or the solutions by sufficiently large number of Monte Carlo simulations. Note whereas the probabilities in the examples are set to vary in the range from 10^{-5} and 10^{-9} , the probabilities of practical interest are often higher. Thus, the degree of the extrapolation in practical applications is smaller, and it is anticipated that the errors of the evaluated probability integrals by the proposed scheme are even smaller. The other two schemes work well for most of the examples except for the critical examples. The scheme proposed by Naess *et al.* (2009) tends to fail for the cases when the basic random variables are significantly different in their tails from the normal random variables (see the example in section 4.1). This is because the extrapolation scheme takes basis in the original space, and the functional form for the extrapolation is postulated based on the asymptotic characteristics of normal variables. The scheme proposed by Bucher (2009) tends to fail for the case of parallel system reliability (see the example in

Table 3. Comparison of the numerical results (values in the brackets are the ratio of the evaluated value by extrapolation over the exact value)

Example	Result			
	Naess <i>et al.</i>	Bucher	Proposed	Exact
Critical example in section 2.1.2	1.35×10^{-4} (2.71×10^2)	3.17×10^{-7} (0.64)	4.99×10^{-7} (1.00)	4.97×10^{-7}
Critical example in section 2.2.2	8.49×10^{-9} (3.45)	5.03×10^{-11} (2.00×10^{-2})	2.46×10^{-9} (1.00)	2.46×10^{-9}
Example 1 (section 4.3)	4.01×10^{-8} (0.97)	1.53×10^{-8} (0.37)	4.14×10^{-8} (1.00)	4.14×10^{-8}
Example 2 (section 4.3)	6.93×10^{-8} (1.67)	2.29×10^{-8} (0.55)	4.66×10^{-8} (1.13)	4.14×10^{-8}
Example 3 (section 4.3)	3.14×10^{-7} (1.03)	2.53×10^{-7} (0.83)	3.05×10^{-7} (1.00)	3.06×10^{-7}
Example 4 (section 4.3)	3.73×10^{-6} (1.00)	4.39×10^{-6} (1.18)	4.38×10^{-6} (1.17)	3.73×10^{-6}
Daniels system	9.11×10^{-6} (1.83)	6.86×10^{-6} (1.38)	4.45×10^{-6} (0.89)	4.99×10^{-6}
Simple truss structure	2.68×10^{-5} (0.96)	2.60×10^{-5} (1.38)	2.60×10^{-5} (1.38)	2.80×10^{-5}
Redundant truss structure	9.94×10^{-7} (1.12)	7.39×10^{-7} (0.83)	7.99×10^{-7} (0.90)	8.88×10^{-7}

section 4.2). Note, however, that the scheme is originally proposed only for the case of component reliability assessment.

5.2. Choice of the Unknown Parameter, k

As mentioned in section 3.3, the number of the active limit state functions k is generally unknown a-priori, yet does not exceed $\tilde{k} = \min \left(n, \max_{m=1, \dots, M} J_m \right)$. A strategy for the choice of the parameter k in the functional form for the extrapolation is to assume $k = \tilde{k}$. The values of k adopted in the examples presented above is listed in Table 4. If the number of the active limit state functions is smaller than \tilde{k} , it is anticipated that the estimated values of $c_i (i = k + 1, \dots, \tilde{k})$ in the curve fitting are close to zero, imposing the restriction $c_i \geq 0$ so that the value of the product term $\prod_{i=k+1}^{\tilde{k}} \Phi(-c_i \lambda)$ varies slowly as a function of λ , hence, it does not significantly contribute to the change of the value of $f(\lambda | \mathbf{q})$ in Eqn 33.

For instance, in the example of Daniels system it is assumed that $k = \tilde{k} = 6$ and the estimated values of $(\hat{c}_1, \hat{c}_2, \hat{c}_3, \hat{c}_4, \hat{c}_5, \hat{c}_6)$ are $(4.97, 1.5 \times 10^{-8}, 1.5 \times 10^{-8}, 1.5 \times 10^{-8}, 1.5 \times 10^{-8}, 1.5 \times 10^{-8})$. Thus, it means that only one of the six limit state functions is effectively active, although the Daniels system is in fact a parallel system. This is consistent with the observation that in the Daniels system the probability of cascading failure given that one of the elements fails is relatively high; hence, the first failure of an element dominantly contributes to the system failure.

5.3. Applicability of the Functional Form for Extrapolation

The asymptotic form (Eqn 21) and its extension thereof (Eqn 33) are derived assuming that there is a single design point on the boundary ∂D of the integral domain D in the standard normal space (see also the derivation of the Theorem 1 in Breitung and Hohenbichler 1989). However, the functional forms are valid for the case of

multiple (yet finite numbers of) design points. In Eqn 19, for all the design points, the values of $|\mathbf{u}_n^*|$ are identical, whereas the values of the

$$\text{constant term } (2\pi)^{-k/2} |\det(\mathbf{A})|^{-1} \left(\prod_{i=1}^k |\gamma_i|^{-1} \right) |\det(\mathbf{B})|^{-1/2}$$

and the exponent $-k$ of λ may differ. In case when the values of k are identical for all the design points, by summing up the respective constant terms, the same form of Eqn 21 is derived. In case when the values of k differ between the design points, only the design point(s) with the largest values of k are asymptotically relevant. By summing up the corresponding constant terms for these design points, the same form of Eqn 21 is derived. For the case when the distances to two or more of the limit state functions are close, and for the case when the number of design points is infinite, the applicability is numerically investigated and is confirmed (Examples 3 and 4 in section 4.3).

Here, it should be mentioned that the term $a(\lambda)$ approximated in Eqn 32 generally plays the role of incorporating all the characteristics of scaled probability integrals $I(\lambda)$ that are not considered in the term $\prod_{i=1}^k \Phi(-c_i \lambda)$, and it is responsible for the asymptotic characteristics of $I(\lambda)$.

5.4. Further Applications of the Proposed Scheme

As further applications of the proposed scheme, reliability assessments of various types of engineered systems, such as high dimensional systems and dynamic systems, are promising. In this respect, Sichani *et al.* (2011a, b) has recently applied the asymptotic approach to high dimensional structural dynamic problems and the first passage probability of high-dimensional nonlinear systems. In these papers, two advantages of the scheme proposed by Bucher (2009) are pointed out. The first advantage is that the method is actually a “black box” method, which does not require any a-priori knowledge of the system. The second advantage is that the scheme has low demand on the data storage of the pre-processing, time history of the previous simulations in terms of excitation or response. Since the proposed scheme in the present paper shares the same principle idea with the scheme by Bucher (2009), it is anticipated that the proposed scheme should have wide applicability as indicated by Sichani *et al.* (2011a, b).

6. CONCLUSIONS

The present paper proposes a new scheme for the probability integral solution by extrapolation for the reliability assessment of complex systems. The idea of

Table 4. Values of k adopted in the examples

Example	k
Critical example in section 2.1.2	1
Critical example in section 2.2.2	3
Example 1 (section 4.3)	2
Example 2 (section 4.3)	2
Example 3 (section 4.3)	1
Example 4 (section 4.3)	1
Daniels system	6
Simple truss structure	1
Redundant truss structure	2

the new scheme comes from the novel class of approaches to the evaluation of probability integrals by Naess *et al.* (2009) and Bucher (2009). The proposed scheme in the present paper is formulated as an extension of the scheme by Nishijima *et al.* (2010) to the cases where the basic random variables are not normal. A number of examples, including critical examples to the approaches by Nishijima *et al.* (2010) and Naess *et al.* (2009), representative series and parallel systems and practical structural systems, are investigated to illustrate the performance of the proposed scheme. It is found that the proposed scheme performs well for all the examples. Finally, technical issues in the implementation of the scheme in practice are discussed.

REFERENCE

- Bleistein, N. and Handelsman, R.A. (1975). *Asymptotic Expansions of Integrals*, Holt, Rinehart and Winston, New York, USA.
- Breitung, K. (1984). "Asymptotic approximations for multinormal integrals", *Journal of Engineering Mechanics*, ASCE, Vol. 110, No. 3, pp. 357–366.
- Breitung, K. and Hohenbichler, M. (1989). "Asymptotic approximations for multivariate integrals with an application to multinormal probabilities", *Journal of Multivariate Analysis*, Vol. 30, No. 1, pp. 80–97.
- Bucher, C. (2009). "Asymptotic sampling for high-dimensional reliability analysis", *Probabilistic Engineering Mechanics*, Vol. 24, No. 4, pp. 504–510.
- Hohenbichler, M., Gollwitzer, S., Kruse, W. and Rackwitz, R. (1987). "New light on first- and second-order reliability methods", *Structural Safety*, Vol. 4, No. 4, pp. 267–284.
- Hohenbichler, M. and Rackwitz, R. (1981). "Non-normal dependent vectors in structural safety", *Journal of Engineering Mechanics Division*, ASCE, Vol. 107, No. 6, pp. 1227–1237.
- Liu, P.L. and Der Kiureghian, A. (1986). "Multivariate distribution models with prescribed marginals and covariances", *Probabilistic Engineering Mechanics*, Vol. 1, No. 2, pp. 105–112.
- Naess, A., Leira, B.J. and Batsevych, O. (2009). "System reliability analysis by enhanced Monte Carlo simulation", *Structural Safety*, Vol. 31, No. 5, pp. 349–355.
- Nishijima, K., Qin, J. and Faber, M.H. (2010). "A scalable parametric approximation to multi-normal probability integrals", *IFIP WG 7.5 Working Conference on Reliability and Optimization of Structural Systems*, Munich, Germany, April, pp. 139–146.
- Sichani, M.T., Nielsen, S.R.K. and Bucher, C. (2011a). "Applications of asymptotic sampling on high dimensional structural dynamic problems", *Structural Safety*, Vol. 33, No. 4–5, pp. 305–316.
- Sichani, M.T., Nielsen, S.R.K. and Bucher, C. (2011b). "Efficient estimation of first passage probability of high-dimensional nonlinear systems", *Probabilistic Engineering Mechanics*, Vol. 26, No. 4, pp. 539–549.
- Song, J. and Der Kiureghian, A. (2003). "Bounds on system reliability by linear programming", *Journal of Engineering Mechanics*, ASCE, Vol. 129, No. 6, pp. 627–636.
- Thoft-Christensen, P. and Murotsu, Y. (1986). *Application of Structural Systems Reliability Theory*, Springer-Verlag Berlin, Heidelberg, Germany.
- Winterstein, S.R. and Bjerager, P. (1987). "The use of higher moments in reliability estimation", *Proceedings of the 11th International Conference on Applications of Statistics and Probability in Civil Engineering*, Vancouver, Canada, pp. 1027–1036.

