

Technical University of Denmark



Post-buckling capacity of bi-axially loaded rectangular steel plates

Jönsson, Jeppe; Bondum, T. H.

Published in:

Proceedings of the 6th International Conference on Coupled Instabilities in Metal Structures

Publication date:

2012

[Link back to DTU Orbit](#)

Citation (APA):

Jönsson, J., & Bondum, T. H. (2012). Post-buckling capacity of bi-axially loaded rectangular steel plates. In Proceedings of the 6th International Conference on Coupled Instabilities in Metal Structures (pp. 571-578)

DTU Library

Technical Information Center of Denmark

General rights

Copyright and moral rights for the publications made accessible in the public portal are retained by the authors and/or other copyright owners and it is a condition of accessing publications that users recognise and abide by the legal requirements associated with these rights.

- Users may download and print one copy of any publication from the public portal for the purpose of private study or research.
- You may not further distribute the material or use it for any profit-making activity or commercial gain
- You may freely distribute the URL identifying the publication in the public portal

If you believe that this document breaches copyright please contact us providing details, and we will remove access to the work immediately and investigate your claim.

POST-BUCKLING CAPACITY OF BI-AXIALLY LOADED RECTANGULAR STEEL PLATES

Jeppe Jönsson^a and Tommi H. Bondum^b

^{a,b} DTU Civil Engineering, Technical University of Denmark

Abstract: Results from a detailed numerical investigation of the post-buckling behaviour of rectangular simply supported steel plates subjected to biaxial in-plane loading are presented. The Steel plates are loaded through forced edge displacements. The effects of initial imperfections, aspect ratio, plate slenderness and edge displacement ratio are included in the investigations presented. Capacity interaction curves are established in the bi-axial stress domain. It turns out that for certain stress ratios the imperfections dominating the ultimate capacity are not affine to the lowest classical buckling mode for biaxial stress. It is of great interest that short wave imperfections of a lower magnitude compared to conventionally used imperfections are seen to lower the capacity of the bi-axially loaded plates. The topic is of major concern in the flange plates of long span bridges with multi box girder configurations.

1. INTRODUCTION

The importance of revisiting this topic has been increasingly recognized in modern long span bridge configurations with multiple box girders joined by transverse girders, thus exposing the common flange plates to varying biaxial loading as for example shown in Fig. 1.

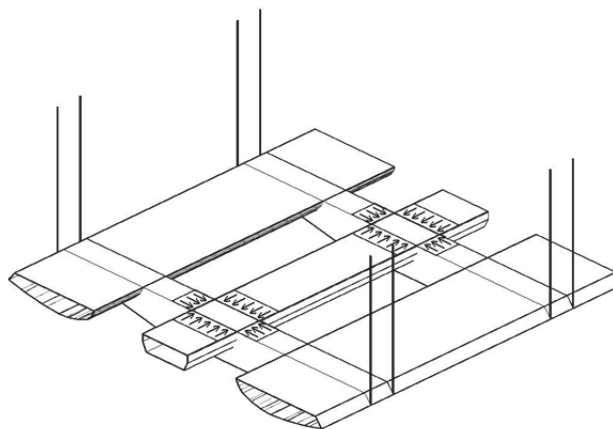

Fig. 1: Sketch of a proposed Messina Strait Bridge configuration

The ultimate state analysis of bridge deck plates or flange plates at the intersections between the main girders and the transverse girder includes bi-axial membrane stresses, which may be in compression or tension. Consequently the flange plates are susceptible to buckling and post-buckling initiated by a combination of actions which need to be accounted for in design. The European standard EN 1993-1-5 [1] offers mainly two methods, namely the effective width approach or the reduced stress approach. However the effective width approach is mainly for situations with a main unidirectional axial stress, with specific interaction formulas for transverse actions and shear. Efficiently it is only the reduced stress method, which tries to cope with the bi-axial stress situation. The reduced stress method is based on the Von Mises yield criterion and on the determination of a single relative slenderness for the complete stress field and the related buckling load. Furthermore it also seems that mainly situations with bi-axial compression have been investigated, whereas situations with compression in one and tension in the other have not been investigated in the same degree.

The presented investigations are based on advanced non-linear finite element analysis of rectangular simply supported plates with proportional uniform in plane edge displacements as shown in Fig. 2. Note that compression stresses are positive. The research includes detailed investigations of the behaviour of plates in the complete interaction domain with a main focus on the influence of the imperfection shape and magnitude. A large number of applied imperfection shapes, constituted by relevant buckling modes, are included in the investigation. The research is based on an imperfection magnitude according to the provisions in EN 1993-1-5 and according to a novel proposal for the short wave imperfection magnitude by the authors. However the influence of residual stresses has been disregarded completely. Based on the obtained results “conservative” capacity interaction curves and corresponding buckling reduction curves are established. The performed analysis is based on a yield stress of $f_y = 350\text{MPa}$, Poisson ratio $\nu = 0.3$, elastic modulus $E = 2.1 \cdot 10^5 \text{MPa}$ and a tangent hardening modulus $E_h = 0.01E$. The plate is considered simply supported and the edges are assumed to remain straight. The loading of the plate is based on forced proportional biaxial edge displacements. The numerical research is based on the provisions in Annex C of EN 1993-1-5 [1] and performed using the finite element program ABAQUS [2]. The geometrical and material non-linear analysis is mainly based on imperfection modes prescribed in Annex C of EN 1993-1-5 as a fraction of the critical (first) buckling mode and on a bi-linear material description using the Von Mises type yield criterion extended to include linear hardening. However further investigations showed that these imperfections may not be conservative in the whole interaction domain.

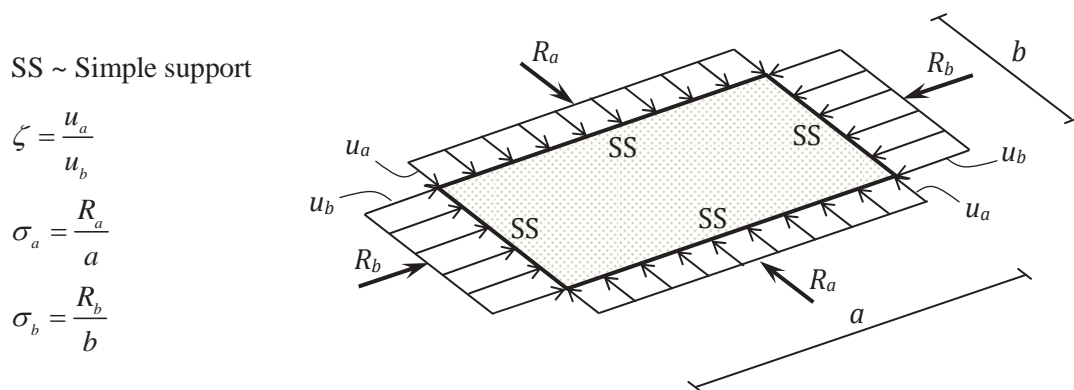

Fig. 2: Bi-axially loaded simply supported plate with proportional edge displacements

In the typical analysis performed in the presented work we first carry out a linear buckling analysis (LBA) in order to obtain the relevant critical buckling loads and buckling mode shapes. Following this a geometrical and material nonlinear imperfect analysis (GMNIA) is carried out to determine the second order elastic-plastic ultimate capacity of the plates and for those susceptible to buckling the post-buckling capacity is determined. In the case of a snap through type behaviour (due to buckling mode transition) the highest peak capacity in the main (dominating) loading direction is used.

Plates subjected to combined loads have been studied extensively during the previous decades. The majority of studies are theoretically based numerical research and only a limited number of experiments have been conducted. In the following a short review on earlier work is performed in order to investigate the influence of the assumptions on which the present research is built. In the thesis of Braun [3] (Section 5.4.4) a numerical study of the influence of edge boundary conditions on the ultimate plate capacity is reported for plates with aspect ratios of $\alpha = 1$ and $\alpha = 3$. In this work Braun compares the interaction curves of plates with respect to constrained versus unconstrained edges as well as clamped versus hinged supports at the edges. He concluded that plates with constrained edges exhibited increasing capacity compared to those with unconstrained edges for increasing slenderness and that these plates have a strength reserve which is not taken into account in EN 1993-1-5 [1]. Braun also found that the capacity of plates with clamped plate support compared to hinged supports increased for increasing slenderness. A plated structure in an actual design situation is commonly supported on edges at webs or at adjacent parts which provide rotational and in-plane stiffness. In other cases the plate is part of a continuous structure whereby load-distribution between the various subpanels is possible. It should be noted that the present study of plates under biaxial loads is based on constrained in plane edge displacements and hinged plate supports. Thereby the results are on one hand favourable in terms of the constrained edges but unfavourable since the plate is free to rotate along the support lines.

Valsgård [4] studied sequential loading of bi-axially loaded plates for a plate with an aspect ratio of $\alpha = 3$. The research was based on initial loading of the short edges to a certain load level and then application of loads on the long edges and vice versa. He clarified that non-proportional loading yields a more favourable plate response than proportional loading. A conservative prediction of the post-buckling capacity of bi-axially loaded plates therefore has to be based on proportional loading. Valsgård's conclusion was later supported by experimental studies carried out by Stonor et al. [5] which were based on proportional and non-proportional loading of plates with aspect ratios of $\alpha = 4$ and 6. Moreover they clarified that for un-welded plates no difference in maximum capacity was noticed.

The paper by Braun [6] describes the research of Dowling et al. [7] who investigated the influence of the imperfection shape on the capacity of plates by superimposing various buckling modes on the geometry. For a plate with aspect ratio of $\alpha = 3$ under biaxial compression, he determined that the least favourable capacities, in a domain with dominating transverse loads, were found for a single half-wave. In the region with dominating longitudinal load the least favourable loads were obtained with three longitudinal half-waves. The present work, however, contradicts this conclusion and reveals that the least favourable interaction curves are based on imperfection shapes consisting of a larger number of longitudinal half-waves. This conclusion particularly concerns slender plates. Additionally the present research reveals that the plate in some interaction domains no longer is able to maintain the mode of imperfection and experiences a mode transition. In order to develop conservative and reliable imperfection curves insight into the various mode transitions in the full interaction domain needs to be established.

Fischer [8] measured the imperfection shapes of fabricated plates and determined that in general plates attain the shape of a single half-wave. The present study shows however, that in

order to establish conservative interaction curves it is necessary to include imperfection shapes with shorter half-waves than conventional “quadratic” half-waves. By including short-waved modes the interaction curves found in this paper are conservative in relation to Fischer’s results.

The investigations presented in this paper have been performed by the authors and in part reported in the master thesis of Bondum [9].

2. BEHAVIOUR OF BI-AXIALLY STRESSED PLATES

The behaviour of bi-axially stressed plates with proportionally displaced straight edges will be briefly described in the present section. For plates, which exhibit buckling and post buckling, the behaviour in the bi-axial stress space is illustrated in Fig. 3. In Fig. 3 (a) two stress paths corresponding to two different proportional displacement load paths are shown for relatively low plate slenderness. In Fig. 3 (b) stress paths corresponding to proportional displacement ratios of $\zeta = 1.0, 0.12$ and 0 are shown dotted for a very slender plate with a single imperfection “buckle” and an aspect ratio of $\alpha = 4$. Furthermore interaction curves are shown (for both dominating transverse loads and dominating longitudinal loads) corresponding to several load paths. The number of peaks related to the interaction curves are indicated together with the number buckles, e.g. 2P5 denotes second peak with five buckles.

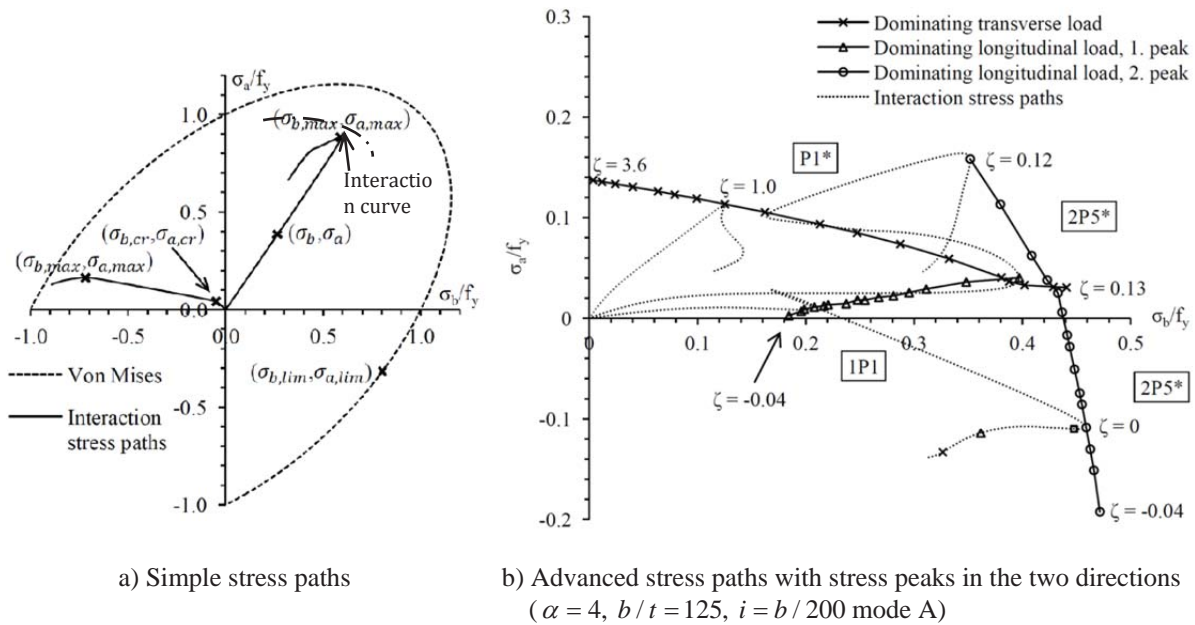

Fig. 3: Examples of stress paths for plates with proportional edge displacements

As seen, the response of plates subjected to bi-axial loads changes significantly for the different domains in the bi-axial interaction plane. The additional peaks observed for the stress values in Fig 3. (b) are explained by the fact that the plate at a certain low edge displacement ratio experiences a mode transition. At this point the plate is no longer able to maintain the single longitudinal half-wave “imperfection buckle” and is forced into a mode transition which results in a shape of the plate consisting of 5 longitudinal half-waves, as shown in Fig. 4. In the following the interaction domain where the transverse compression governs the displacement behaviour with a single longitudinal buckle will be referred to as *dominating transverse compression domain*, whereas the interaction domain where the

longitudinal compression governs the behaviour with multiple buckles is referred to as *dominating longitudinal compression domain*.

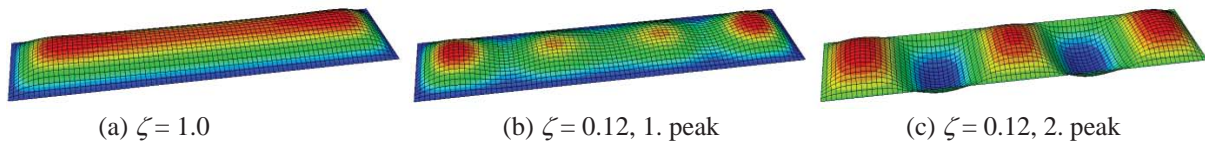

Fig. 4: Out-of-plane displacement state in plate at peak ($\alpha = 4$, $b/t = 125$)

The mode transition provides the plate with additional transverse capacity which is constituted by the transverse sections that remain straight. This is the explanation for the jump or increase in maximum transverse stress after the first peak. The mode transition also causes a drop of the longitudinal capacity since the membrane effect in this direction decreases as the shape of the plate consists of an increasing number of buckles. Since the plate for certain modes and regions in the interaction domain experiences mode transitions, it is of interest to investigate the influence of the imperfection shape on the behaviour and capacity for a wide number of modes in order to establish conservative interaction curves in the full interaction domain.

Imperfections

In the presented work the imperfection modes are labelled as imperfection modes A through J corresponding to 1 to 10 longitudinal half-wave buckles, respectively. The imperfection magnitude according to the provisions in EN 1993-1-5 is given by

$$i = \min\left(\frac{b}{200}, \frac{a}{200}\right) \quad (1)$$

However in order to account for a higher frequency of longitudinal imperfection buckles it is proposed that the imperfection magnitude is related to the smallest longitudinal (or transverse) half-wave length as follows

$$i = \min\left(\frac{b}{n \cdot 200}, \frac{a}{m \cdot 200}\right) \quad (12)$$

In which n and m are the number of half wave buckles in the transverse and longitudinal direction respectively. Fig. 5 illustrates the imperfection magnitude according to EN 1993-1-5 and according to the proposed imperfection magnitude for mode A and G.

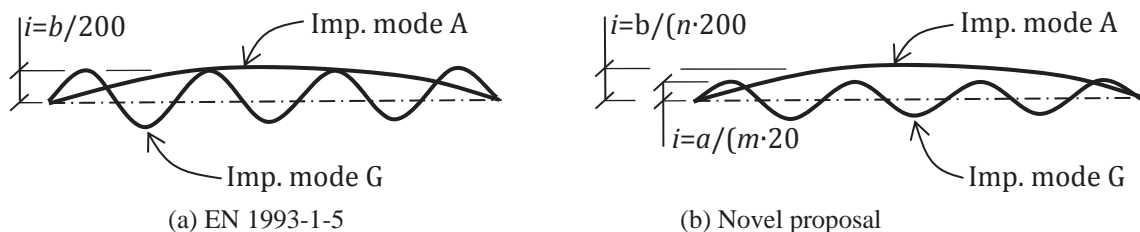
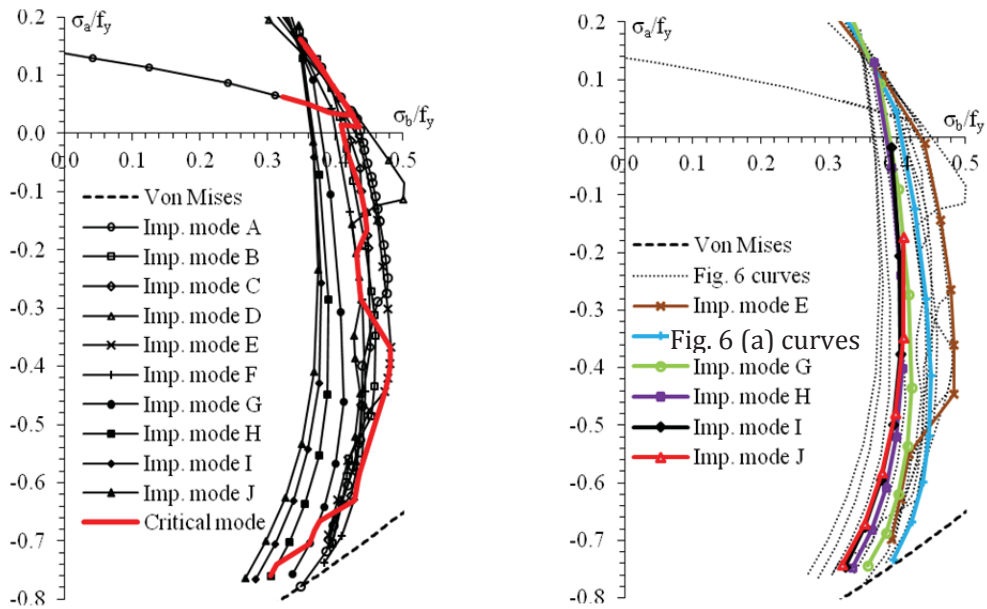

Fig 5: Imperfection magnitude for buckling mode A and G.

Dominating longitudinal compression domain

For numerical design of steel plates both geometric and structural imperfections should be included. Due to the provisions of EN 1993-1-5 these imperfections can be accounted for by superimposing the critical imperfection mode (determined as the mode related to the lowest buckling load factor) on the plate geometry with an imperfection magnitude according to Eq.

(1). In order to determine whether the approach according to EN 1993-1-5 in the interaction domain with dominating longitudinal compression is conservative or not, the interaction curve based on the critical imperfection mode is established using an imperfection magnitude according to Eq. (1), see Fig 6 (a).



(a) EN 1993-1-5 imperfection magnitude, Eq. (1)

(b) Proposed imperfection magnitude, Eq. (2)

Fig. 6: Interaction curves for various imperfection modes including the critical mode shape for dominating longitudinal compression ($\alpha = 4$, $b/t = 125$)

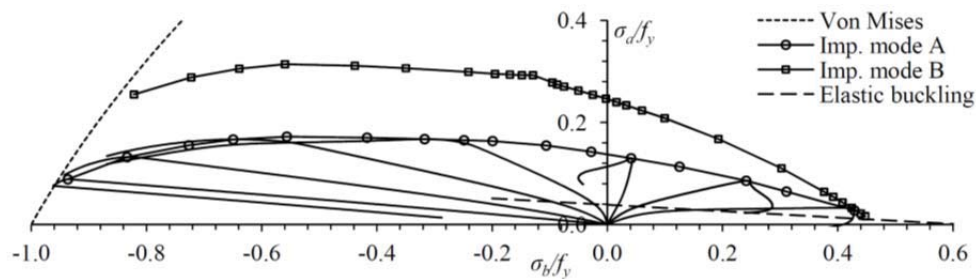

Fig 7: Conservative interaction curve for imperfection mode A and B for dominating transverse compression ($\alpha = 4$, $b/t = 125$)

To clarify the influence of the imperfection shape additional interaction curves are found for imperfection modes A through J. Note that each kink on the curves indicates a mode transition. The figure illustrates that the interaction curve based on an imperfection shape of the critical mode is far from the most conservative. Generally the longitudinal capacity is seen to decrease for the higher imperfection modes which is explained by that energy dissipation of the plate in a larger degree is constituted by bending for increasing half-waves in the shape. As described in the preceding the imperfection magnitude according to EN 1993-1-5 is considered very conservative for the short wave length imperfections (multiple imp. buckles) in the considered interaction domain. For this reason interaction curves are instead found based on the proposed imperfection magnitudes Eq. (2) as illustrated with the dotted curves based on EN 1993-1-5 imperfection magnitudes in Fig 6(b). For the higher imperfection mode the longitudinal capacity is seen to increase compared to the curves based on EN 1993-1-5

imperfection magnitudes which is a consequence of the relative smaller imperfection magnitude for the higher modes. The figure also shows that the most conservative interaction curve for the proposed imperfection magnitudes is constituted by intersecting interaction curves for the various modes. Additionally it is found that the interaction curves constituting the conservative interaction curve do not include any mode transitions thus snap-through behaviour of the plate can be ignored when establishing conservative interaction curves.

Dominating transverse compression domain

The maximum capacity of a plate is investigated for the interaction domain with dominating transverse compression. Interaction curves are established for imperfection mode A and B as shown in Fig. 7 which also illustrates selected stress paths for mode A. The figure reveals a consistency of the interaction curves which is explained by the observation that in the complete interaction domain the imperfection shape is maintained until collapse. The transverse capacity is seen to increase for higher imperfection mode which is obviously as a result of the increasing number of straight transverse sections causing additional transverse post-buckling capacity for the higher mode. Consequently imperfection mode A yields the most conservative capacity of the plate in this domain for the plate with an aspect ratio of 4.

3. ULTIMATE CAPACITY DEPENDENT ON SLENDERNESS AND ASPECT RATIO

The preceding investigations are used as basis for establishment of “conservative” interaction curves or ultimate capacity curves in the complete interaction domain, so that the ultimate capacity can be determined as exemplified in the previous section. To establish the interaction curves in the complete domain distinctive points of transition from the region with dominating transverse to the region with dominating longitudinal compression need to be determined. These points correspond to transitions from a curve with imperfection mode A to a curve with a higher number of imperfection buckles and this point is referred to as a *primary transition*. Next the transitions between the curves with higher order imperfections in the range with dominating longitudinal compression are to be identified. These are referred to as *secondary transitions*. In the investigations performed three slenderness values and three different aspect ratios have been used. The found corresponding conservative interaction curves with indication of primary and secondary transitions are shown in Fig. 8.

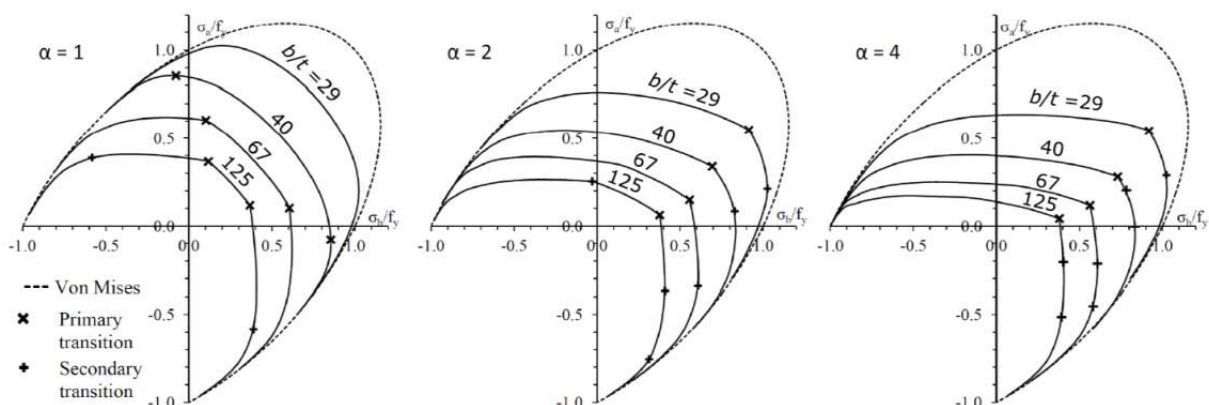

Fig 8: The established ultimate capacity curves in stress space.

4. CONCLUSIONS

Results from a detailed investigation of the ultimate capacity of simply supported rectangular plates subjected to biaxial loads have been reported. The full interaction domain has been investigated for a variety of imperfections. Following conclusions may be drawn:

1. In parts of the interaction domain non-standard imperfection modes lead to lower ultimate capacity than the critical buckling mode imperfections traditionally used.
2. A novel proposal for handling the magnitudes of short-waved imperfections has been given. However it has to be calibrated to measured imperfections of real structures.
3. For plate behavior dominated by transverse compression the conservative interaction curves should be based on the imperfection shape of a single longitudinal half-wave.
4. For plate behavior dominated by longitudinal compression the conservative interaction curves should be based on imperfection modes with a large number of half-waves.
5. For each investigated slenderness and displacement ratio the capacity of the plate converged towards a certain number of longitudinal half-waves for which the most unfavorable value was obtained.
6. It was found that all the final conservative interaction curves are based on stress paths for imperfection shapes that do not involve buckling mode transitions.

Implementation of the effective width concept might be possible since the preceding investigations include both the behaviour and capacity of plates in the complete interaction domain.

References

- [1] EN 1993-1-5. *Eurocode 3 - Design of steel structures - Part 1-5: Plated structural elements*, European Committee for Standardization, Brussels, 2007
- [2] ABAQUS CAE, v6.8, Simulia, 2008
- [3] Braun BT. *Stability of steel plates under combined loading*, Dissertation, No. 2010-3, Institute of Structural Design, University of Stuttgart, 2010
- [4] Valsgård S. "Numerical design prediction of the capacity of plates in biaxial in-plane compression", *Computers and Structures*, vol. 12, 729-739, 1980
- [5] Stonor RWP, Bradfield CD, Moxham KE. "Tests of Long Plates Under Biaxial Compression", *J. Construct. Steel Research* 24, 25-56, 1992
- [6] Braun BT. "Reduced stress design of plates under biaxial compression", *Steel Construction* 5, No. 1, 2012
- [7] Dowling PS, Harding JE, Slatford JE. "Strength of Ships Plating – Plates in biaxial compression", *CESLIC Report SP4*, Department of Civil Engineering, Imperial College, London, 1979
- [8] Fischer M, Grube R, Rieger H, Wenk P. *Messungen der vorverformungen von beulgefährdeten stahlblechen mit und ohne steifen*, University of Dortmund, 1989
- [9] Bondum TH. *Stability Analysis of Biaxially Loaded Steel Plates*, Master Thesis, Department of Civil Engineering, Technical University of Denmark, 2012