

Technical University of Denmark



Danish Experiences with Deposit Probe Measurements in Grate and Pulverized Fuel Biomass Power Boilers

Hansen, Stine Broholm; Jensen, Peter Arendt; Jappe Frandsen, Flemming; Wu, Hao; Sander, Bo; Wadenbäck, J.; Glarborg, Peter

Published in:

Proceedings of the 20th European Biomass Conference and Exhibition

Publication date:

2012

[Link back to DTU Orbit](#)

Citation (APA):

Hansen, S. B., Jensen, P. A., Jappe Frandsen, F., Wu, H., Sander, B., Wadenbäck, J., & Glarborg, P. (2012). Danish Experiences with Deposit Probe Measurements in Grate and Pulverized Fuel Biomass Power Boilers. In Proceedings of the 20th European Biomass Conference and Exhibition

DTU Library

Technical Information Center of Denmark

General rights

Copyright and moral rights for the publications made accessible in the public portal are retained by the authors and/or other copyright owners and it is a condition of accessing publications that users recognise and abide by the legal requirements associated with these rights.

- Users may download and print one copy of any publication from the public portal for the purpose of private study or research.
- You may not further distribute the material or use it for any profit-making activity or commercial gain
- You may freely distribute the URL identifying the publication in the public portal

If you believe that this document breaches copyright please contact us providing details, and we will remove access to the work immediately and investigate your claim.

DANISH EXPERIENCES WITH DEPOSIT PROBE MEASUREMENTS IN GRATE AND PULVERIZED FUEL BIOMASS POWER BOILERS

S.B. Hansen¹, P.A. Jensen¹, F.J. Frandsen¹, H. Wu¹, B. Sander², J. Wadenbäck³, P. Glarborg¹

¹: Department of Chemical and Biochemical Engineering, Technical University of Denmark, Building 229, DK-2800, Lyngby, Denmark.

²: DONG Energy Thermal Power, Kraftværksvej 53, DK-7000 Fredericia, Denmark

³: Vattenfall A/S, Amagerværket, kraftværksvej 37, DK-2300 Copenhagen S, Denmark

ABSTRACT:

Several measuring campaigns with focus on deposition behavior have been conducted at full-scale power plants firing biomass in Denmark. These campaigns have been reviewed in this work. The focus is the obtained experiences on deposit formation, shedding and chemistry.

When comparing results from grate- and suspension-firing, it is found that the rates of deposit formation are comparable, while the chemical composition of the fly ashes are quite different, even for the same type of fuel. The flue gas temperature is considered to be an important parameter in the deposit behavior. Increasing the flue gas temperature leads to increased deposition rates and deposits with higher contents of Si and Ca and lower contents of K and Cl.

The shedding behavior is influenced by both probe surface temperature, flue gas temperature and deposits chemistry. The influence of temperature on the degree of sintering varies with the fuel type. Possibly, increased contents of Si and Ca leads to increases in the sintering temperature and thus altered shedding behavior.

Keywords: dedicated biopower plant, industrial scale application, straw, wood, fly ashes, deposits,

1 INTRODUCTION

As a consequence of Danish and international energy policy during the last 30-35 years, several full-scale measuring campaigns have been conducted in order to investigate the thermal conversion and utilization of straw for heat and power production - either in dedicated, grate-fired plants, in conjunction with coal in PF boilers and lately also in dedicated biomass (wood and/or straw) fired PF boilers.

Utilization of biomass for power production may increase the rate of formation of deposits, which are difficult to remove especially in the boiler chamber and on superheater coil surfaces compared to those formed during coal firing.

The difficulty arises from a high K-content of the biofuels, as potassium partly vaporizes and form chlorides and sulfates, which may condense on heat transfer surfaces. Potassium may also form low-melting Si-rich particles, which may stick to the heat transfer surfaces upon impaction [1]. Deposits are formed in biomass-fired boilers by at least four different mechanisms; Inertial impaction, thermophoresis, condensation and heterogeneous reaction [2]. The four mechanisms apply to different parts of the flue gas or fly ash. The large fly ash particles (>10 μm) are deposited by inertial impaction, when the particles have sufficient inertia to traverse the gas stream lines around a tube. Whether the particles then stick to the probe or are rebound, depends on the stickiness of the particle and deposit surface, thus on the melt fractions. Small aerosol particles (< 1 μm), often KCl or K_2SO_4 , are deposited by thermophoresis, where a temperature gradient is the driving force for the transport of the particles through the gas phase toward the cold probe surface. KCl or K_2SO_4 are also found as gaseous components in the flue gas. These may either condense or react on the deposit surface. The gas components are thus transported toward the surface by diffusion, with a concentration gradient being the driving force [2].

Once formed, the deposits may be removed from heat

transfer surfaces by shedding, either naturally or induced by e.g. soot-blowing. Various mechanisms of natural deposit shedding have been identified; erosion, gravity force (debonding/ melting) and thermal stresses. The occurrence of shedding events depend on various physical parameters of the deposits; tensile and adhesive strengths, elastic properties, viscosity, melting behavior, thermal expansion coefficient and thermal properties. These physical properties leads back to the chemical composition and the temperature of the deposit, but are often complicated to describe [3].

In order to handle ash related boiler problems, careful design of boiler chambers, superheaters and soot-blowing equipment have been developed. To support the development of biomass combustion equipment, deposit probe measurements have been conducted in the last 20 years on many of the power plant boilers in Denmark. The measuring campaigns have been conducted in collaboration between power plant owners (now DONG Energy and Vattenfall) and Technical University of Denmark (DTU).

The focus of the present study is a review of the full-scale measuring campaigns, where biomass is fired without coal. The study includes a review of the applied experimental probe techniques, and an overview of data gained on deposit build-up rates, deposit removal, deposit chemistry and the influence of fuel type and boiler operation conditions on the processes.

2 EXPERIMENTAL

The experiments reviewed in this study have been conducted at several Danish CHP plants, both grate and suspension fired. The data for the plants are seen in Table 1. It should be noted that Avedøre unit 2 includes two boilers; a straw fired grate boiler and a wood/oil/gas fired suspension boiler, which both provides steam for the steam turbine.

Table 1: Power plant data for the plants mentioned in this work [4-11]

	Type	Fuel	input MW _{th}	Steam °C	Year Bar	
Haslev	Cigar	Straw	23	450	67	1989
Slagelse	Grate	Straw	31	450	67	1990
Rudkøbing	Grate	Straw	10.7	450	60	1990
Masnedø	Grate	Straw	33	522	92	1996
Ensted	Grate	Straw	100	470	200	1998
Avedøre	Grate	Straw	100	545	310	2001
Avedøre	Susp.	Wood	800	560	300	2001
Amager 1	Susp.	Straw /wood	350	540	185	1971 /2008
Amager 2	Susp.	Straw /wood	250	480	100	1972 /2003
Jordbro	Susp.	Wood	80			1968

In the investigated grate fired units straw is the primary fuel. The straw is fed to the boiler on a grate where the combustion takes place. Primary combustion air passes through the grate, and the temperature in the fuel-bed on the grate is typically in the range 1000-1200 °C [12]. From the grate, the majority of the ash is dumped into the ash pit at the end of the grate, while only a small fraction (typically less than 20 wt%) is entrained with the flue gas [13]. One of the CHP-plants included in this study, is ‘cigar-fired’, which implies that whole straw bales are introduced to the furnace and burn along the surface of the bale, where primary air is introduced by a jet, thereby stabilizing the combustion on the surface [7].

Table 2 lists the ash related measuring campaigns conducted in grate boilers and the type of examinations performed. For grate-fired boilers, the investigations include both analyses of deposits collected on probes, and of mature deposits collected from superheater tubes in the plant. The data set includes quantification of rate of deposit formation, chemical analyses, and sometimes corrosion studies and shedding observations.

In biomass suspension-fired units, both wood and straw pellets have been utilized as fuels. The fuel is milled to obtain small particle sizes (< 2 mm) before entering the furnace together with the preheated primary combustion air. The combustion then takes place in suspension, at temperatures up to 1600 °C [12]. A small fraction of the fuel ash particles may end up in the bottom ash, while most of the fly ash particles formed will be transported through the furnace with the flue gas [12].

Table 3 lists the ash related measuring campaigns conducted and the type of examinations performed in biomass suspension fired boilers.

In suspension fired units, only probe deposits have been examined, until now. The focus of these examinations has been on rate of deposit formation, chemistry of deposits, and shedding observations.

Two types of deposition probes have been applied in the conducted experiments. Both simple air-cooled probes, as well as more advanced probes for in-situ deposit measurements and soot-blowing have been applied. In the early experiments air-cooled probes were employed. An air-cooled probe is a stainless steel probe with thermocouples placed along the probe surface in order to control the probe temperature to a given set-point by adjusting the air flow-rate. The deposits mass is determined by extracting the probe after each experiment, and subsequently remove the deposits for weighing and analysis [7,9].

In later studies, an advanced shedding probe has been

Table 2: Overview of the full-scale grate experiments performed in Denmark. All furnaces are straw-fired

			Method	Examinations				
Ref.	Boiler	Place*	Probe measurements	Mature deposits samples	Buildup-rate	Chemistry of dep.	Corrosion	Shedding
[7]	Haslev	F, S	X		X	X		
	Slagelse		X		X	X		
[8]	Rudkøb.	F	X		X	X	X	
[9]	Masnedø	S	X	X	X			
[14]	Ensted	S		X	X			
	Masnedø			X				
[15]	Avedøre	CP	X		X	X		X
[16]	Avedøre	S,CP	X		X	X		
	Ensted		X					
[17]	Avedøre	S	X		X			X

*F = Furnace, S = Superheaters, CP = convective pass

Table 3: Overview of the full-scale suspension fired experiments performed in Denmark

			Method	Examinations			
Boiler	Fuel**	Place*	Probe measurements	Mature deposit samples	Buildup-rate	Chemistry of deposits	Shedding
[18]	Jordbro	W	S	X		X	X
[19]	Amager	S	S,T	X		X	
[20]	Avedøre	W/C	F	X		X	X
[11]	Amager	S/W	S,T	X		X	X
[21]	Avedøre	W/C	F	X		X	X (X)
[22]	Avedøre	W/C	F,S	X		X	X (X)

*Place; F = Furnace, S = Superheater, T = Tube bank

**Fuel; W = wood, S = Straw, C = Coal ash added

utilized, see Figure 1.

The in situ deposit probe is constructed of a double annular tube which ensures a uniform cooling of the probe by water and compressed air in counter-current flow. The probe is equipped with a load cell, and online quantification of mass and heat uptake is possible. The flue gas temperature can be measured, both by a thermocouple and by a nearby suction pyrometer, and the deposit formation and shedding can be observed by a video camera [10,11,15,21,22].

3 RESULTS AND DISCUSSION

The results obtained in the full-scale measuring campaigns will be reviewed and compared. The focus is the rate of deposit formation, the chemistry of deposit and the observations on shedding. When examining the

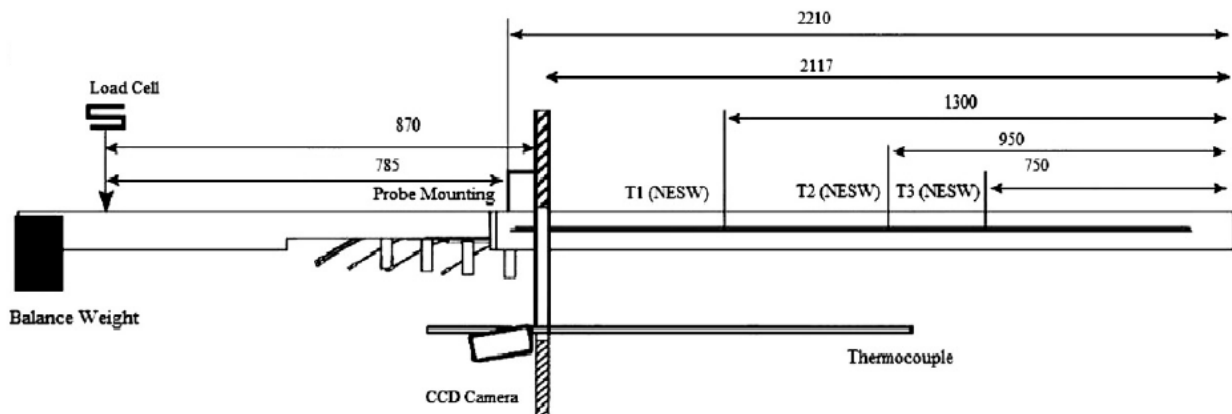

Figure 1: Advanced probe [11]

full-scale experimental results, it should be kept in mind that full-scale boilers are not very well-controlled with respect to operational parameters. Large variations in flows, temperatures, fuel compositions etc. may occur within a relatively short time. Thus, at best only major influences of operational parameters changes may be observed.

3.1 Rates of Deposit Build-up

The rate at which the deposits are formed in a biomass-fired boiler is important, since a decrease in the heat transfer from the flue gas to the steam cycle may be associated with an increase in deposit mass (2).

When looking at the rate of deposit formation [$\text{g}/\text{m}^2/\text{h}$], two definitions of the buildup-rate of deposits have been employed, 1) the Integrated Deposit Formation rate (IDF rate) and 2) the Derivative-based Deposit Formation rate (DDF rate), as defined by Bashir et al. [10]. The IDF-rate is determined by determining the deposit mass on the probe, at a given time after the probe is introduced to the flue gas. The deposit mass is then divided by the probe surface area and the time of exposure, and the rate [$\text{g}/\text{m}^2/\text{h}$] is determined. By this method the build-up rate may be influenced by shedding events, by which deposit is removed from the probe.

The DDF-rate can be obtained by monitoring the mass uptake signal from the advanced probe. The DDF rate is then determined by calculating the time derivative of the deposit mass uptake between two shedding events [g/h] and dividing this rate by the probe surface area. By this method only small shedding events which cannot be separated from the measuring noise are included in the build-up rate. The DDF rate has mainly been employed in recent studies on suspension firing [10,21,22].

In Figure 2, the IDF rates measured are seen as function of local flue gas temperature for grate (or cigar) fired and suspension fired units. It is seen that for grate fired units there seem to be a correlation between the flue gas temperature and the deposit build-up rate. The probe temperatures vary within 400-650 °C in the experiments, with most probes set to around 500 °C. The influence of probe temperature has been examined by Jensen et al. [15], with the conclusion that the probe temperature has limited influence on the deposit formation rate.

For suspension fired units, it can be seen in Figure 2B that the data are rather scattered. For these data, it should be noted that they are obtained in quite different

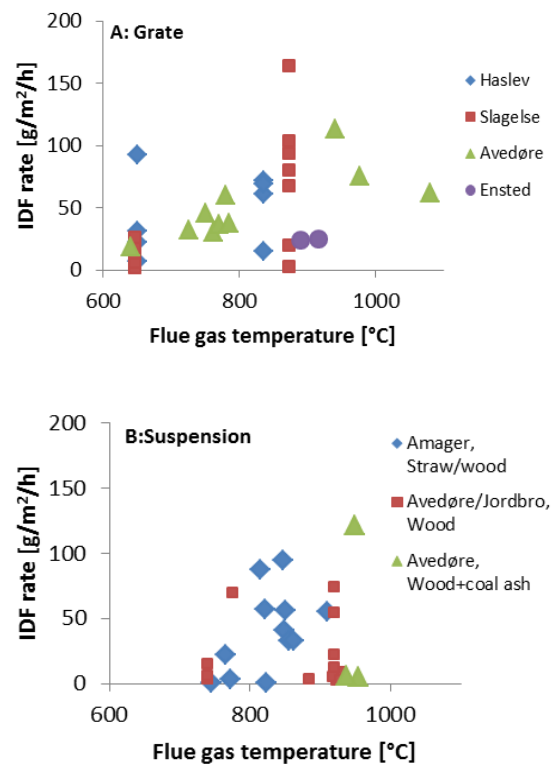

Figure 2: IDF-rates as function of local flue gas temperature.

A: Grate fired units, all straw fired. Probe temperatures are 510 °C at Haslev and Slagelse, 650 °C at Ensted and 400-650 °C at Avedøre [7,15,16].

B: suspension fired units. Probe temperatures are within 470-590 °C [10,11,18,20,22].

scenarios, both with respect to boiler configuration and fuel type.

It can be observed from Figure 2, that the IDF rates for grate and suspension fired units are comparable, as most IDF-rates are in the range 0-100 $\text{g}/\text{m}^2/\text{h}$ for both technologies. This observation is surprising since during grate firing only up to 20 wt% ash is entrained while 80-90 wt% of the ash is expected to end up in the fly ash during suspension firing [13]. For the cigar fired unit, the entrainment is considered to be higher than in grate-fired units [7].

In order to compare the deposit buildup for different fuel and combustion systems an ash propensity has been calculated. The ash propensity is defined as:

$$\text{Ash propensity [\%]} = \frac{\text{Deposit flux [g/m}^2\text{/h]}}{\text{Ash flux [g/m}^2\text{/h]}} \cdot 100\%$$

The deposit flux is the IDF-or the DDF-rate, while the ash flux describes the local ash flow near the probes. The ash flux is calculated by:

$$\text{Ash flux [g/m}^2\text{/h]} = \frac{\text{Fuel flow [g/h]} \cdot \text{Ash content} \cdot \text{Entrainment}}{\text{Cross sectional area at probe position [m}^2\text{]}}$$

Calculation of the ash flux has to rely on some assumptions. The fuel flow in the boilers is assumed to be equal to full load of the boiler, unless stated otherwise in the references. The ash content (as fraction) of the fuel is in all references either provided by analysis of the actual fuel or assumed based on earlier fuel analyses at the plant. The boiler dimensions at the probe positions have been obtained by communications with the owners of the boilers (DONG Energy or Vattenfall A/S). The cross-sectional area of the Haslev cigar boiler could not be obtained. The fraction of ash entrained may vary in the different boilers and can only be roughly estimated. It is assumed that in suspension fired units, the entrainment is 80 % of the fuel ash, while in grate fired units the entrainment is assumed to be 10 %, based on a mass balance provided in ref. [15].

The calculated ash propensities based on IDF rates are seen in Figure 3. It is seen that the ash deposition propensities are much higher for grate fired units than for the suspension fired units. For grate fired units up to 10 % of the ash entrained may deposit on the probe, while for suspension fired units only up to 1 % is deposited. Most of the data is below 0.5 % for suspension-firing. The difference in the ash propensities of the two combustion systems may be explained by differences in the chemical composition of the fly ash, which will be examined later.

It is seen in Figure 2A and Figure 3A that for grate-fired boilers the IDF-rate and the ash deposition propensity increase with the local flue gas temperature. However, as can be seen in the scattering of the data from Slagelse, obtained at the same temperature, other parameters also influence the rate of deposit formation. In Figure 4, the influence of the ash propensity or IDF rate is seen as function of the fuel ash content from the measuring campaigns where the fuel ash was sampled before each experiment [7; 16].

It is seen that there is a correlation between the K-content in the fuel ash and the deposit formation rate whether this is expressed as an IDF-rate or an ash deposition propensity. In the upper figures showing the IDF-rates it is seen that the data from Haslev and Slagelse each may follow linear correlations, as also found in the original work [7].

In the lower figures, the ash deposition propensities are shown, and data from different boilers can be compared. For flue gas temperatures lower than 800 °C, it is seen that there is quite a difference in the data from Avedøre and Slagelse. This may be due to differences in probe temperature (500 °C at Slagelse vs. 650 °C at Avedøre),

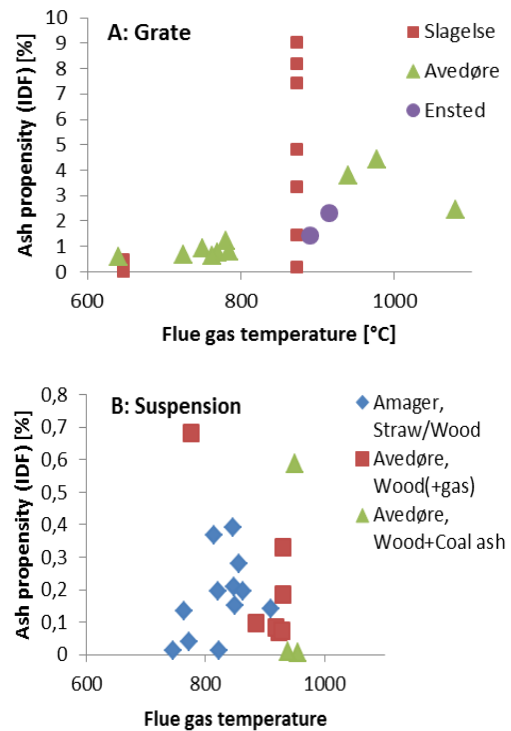

Figure 3: Ash deposition propensities based on IDF rates as function of local flue gas temperature.

A: Grate fired units, all straw fired [7,15,16].

B: Suspension fired units [10,11,18-20,22].

Probe surface temperatures as described in Figure 2.

which may have a rather significant effect at low gas temperatures (650-760 °C). For flue gas temperatures above 800 °C, obtained in or near the furnaces of the plants, it is seen that there is a correlation between the K-content in the fuel ash and the ash deposition propensity which may apply to all grate fired plants included in the comparison. In these data, there are also differences in the probe temperatures (510 °C vs. 650 °C), but this seems to be of minor importance at these temperatures.

For grate fired units it seems that an increased deposition rate can be expected when the fuel ash K-content and the flue gas temperature are increased. For suspension firing, a rather large scattering of data was observed whether the IDF-rate (Figure 2B) or the ash propensity (based on IDF rates, Figure 3B) was shown as function of flue gas temperature. In the experiments performed on suspension firing, chemical analysis of the fuel mixture is not conducted before each experiment, so the IDF-rate cannot be correlated to the K-content of the fuel as was done for the grate fired units. The influence of fuel composition is however examined by plotting the IDF rate as function of the straw share in wood. This is seen in Figure 5. The experiments with wood with coal ash addition are excluded from the comparison. It seems as if the fuel composition does influence the rate of deposit formation. However, any clear trend cannot be determined based on these rather scattered data.

In recent measuring campaigns, where the advanced probe was used, the DDF-rate was calculated by only including the deposit mass change between major shedding events. The DDF-rates are seen as function of flue gas temperature in Figure 6.

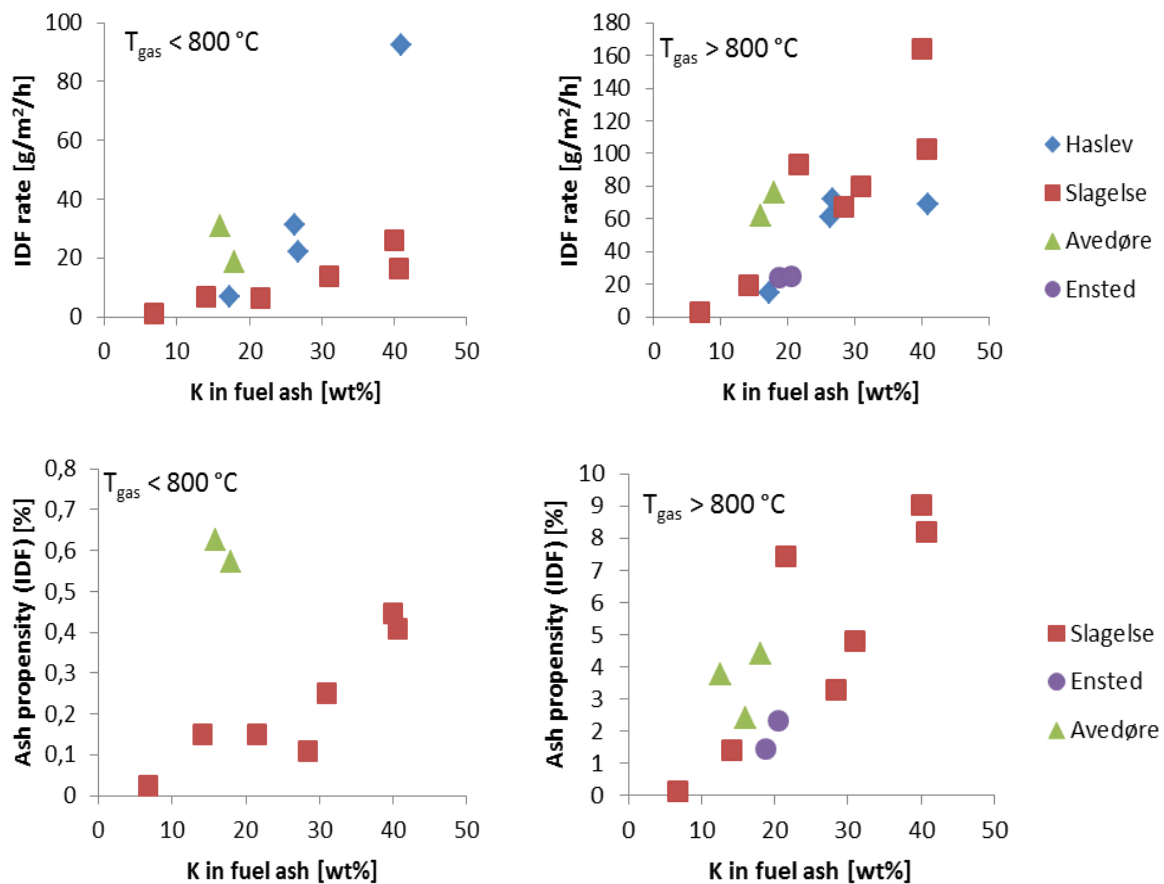

Figure 4: IDF rates (upper figures) and ash propensities (lower figures) as function of the fuel ash K content for grate boilers. Left figures; Flue gas temperatures < 800 °C. Right figures; Flue gas temperatures > 800 °C. Data from refs [7,15,16]. Probe temperatures: Haslev and Slagelse = 510 °C, Avedøre and Ensted = 650 °C

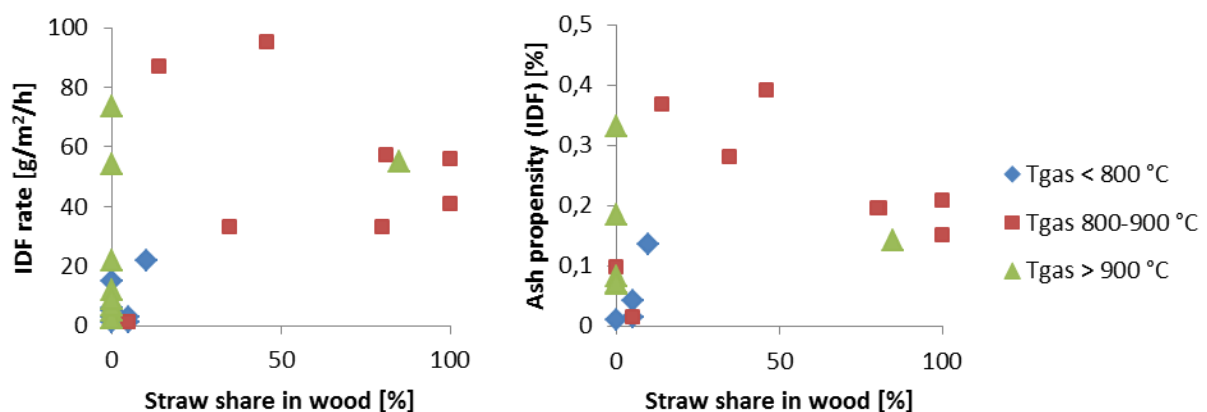

Figure 5: IDF rate (left figure) and ash propensity (right figure) in suspension fired units as function of the straw share in wood. Colors indicate the flue gas temperature. Data from Jorbo, Avedøre and Amager [10,11,18-20,22]. Data with coal ash addition are omitted.

It is seen that there are more data available for the DDF-rates, than for the IDF-rates. This has two explanations; the DDF-rate is calculated several times during each experiment, while only one IDF rate is obtained, typically for the first 12 hours. Secondly, in

some experiments complete shedding of the deposits are observed. In that case it does not make sense to calculate an IDF rate. This behavior is observed for wood and wood + coal ash combustion at high temperatures > 1100 °C.

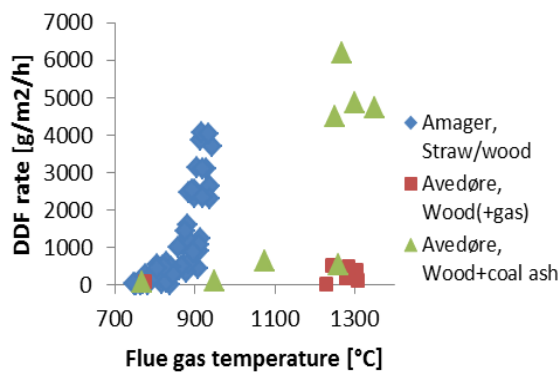

Figure 6: DDF rate vs. flue gas temperature for suspension fired boilers. Data from refs [10,21,22]. The probe surface temperatures are within 470-590 °C

It is seen in Figure 6 that for the straw/wood fuel mixture and the wood with coal ash addition, there seem to be a correlation between the DDF-rate and the flue gas temperature, as the rate of deposit formation increases when the flue gas temperature increases. The temperature dependence is however not similar for the three fuel mixtures. The data with the straw/wood fuel mixture are obtained with flue gas temperatures in the range 750-950 °C. However, combustion of wood at much higher temperatures, above 1200 °C, resulted in much lower deposit formation rates. It thus seems that the fuel ash content and composition as well as the flue gas temperature have an effect on the deposit formation rate.

Again, no fuel chemical analysis is available for each experiment, so the influence of fuel composition is examined by plotting the DDF rate or ash propensity (based on DDF rate) as function of the straw share in wood. The straw share has been estimated by sampling the fuel and determining the fuel ash fraction, for each experiment. The experiments where wood with coal ash addition is used as fuel are excluded from the comparison. It is seen that the influence of fuel composition on the deposit formation is limited.

The difference in the temperature dependence for the various fuels observed in Figure 6, may thus also be caused by other differences in the boilers, as these are quite different in construction.

When examining the IDF- and DDF-rate obtained for suspension firing, the temperature seems to play a role in

the DDF-rate, while the fuel composition mainly seem to influence the IDF-rate, though no clear correlation could be detected. That the fuel composition seems to have a larger influence on the IDF-rate than on the DDF-rate may be explained by the fact that major shedding events are included in the IDF-rate. These shedding events will thus have a large impact on the IDF-rate and not on the DDF-rate. The chemistry of ash and deposits may have more influence on the deposit shedding than on the deposit formation.

3.1 Chemistry of Ash and Deposits

It was seen in the previous section, that the deposit formation rates (IDF) was on similar levels for grate and suspension-fired units (Figure 2). This was explored further by examining the ash propensity of the two systems (Figure 3) and it was found that for grate-fired units up to 10 % of the incoming ash may deposit on the probe, while for suspension-fired units only up to 1 % is deposited (based on IDF-rates). The ash in grate-fired units is thus more prone to end up as deposits than the ash in suspension-fired units. As the temperatures in the systems were similar, the difference may be caused by chemical differences of the fly ashes.

In Figure 8 fuel ash compositions are compared to fly ash compositions obtained from grate and suspension firing. Points on or near the diagonal line indicate that the fuel and fly ash compositions are similar. The chemical examinations in this work mainly focus on the five major ash forming elements; K, Cl, S, Si and Ca. It is seen that for grate-firing, the fly ash composition is quite different from the fuel ash composition. The fly ash is rich in K, Cl and S and depleted of Si and Ca. This is contrary to suspension-firing, where the fly ash to a large extent resembles the fuel ash. Only a slight enrichment of K, Cl and S is found in this combustion system. The difference in the fly ash formation behavior can be explained by the difference in entrainment of ash in the two combustion systems. As K, Cl and S are volatile elements in the fuel, these are to some extent released to the gas phase in the combustion zone, while Ca and Si are retained in the solid fuel (or ash) particles. In grate-firing most of the solid ash particles remain in the bottom of the furnace and Ca and Si are thus only found in the fly ash to a limited extent. Contrary, in suspension-firing the ash particles are entrained to a large extent, which leads to the similar composition of the fuel ash and fly ash.

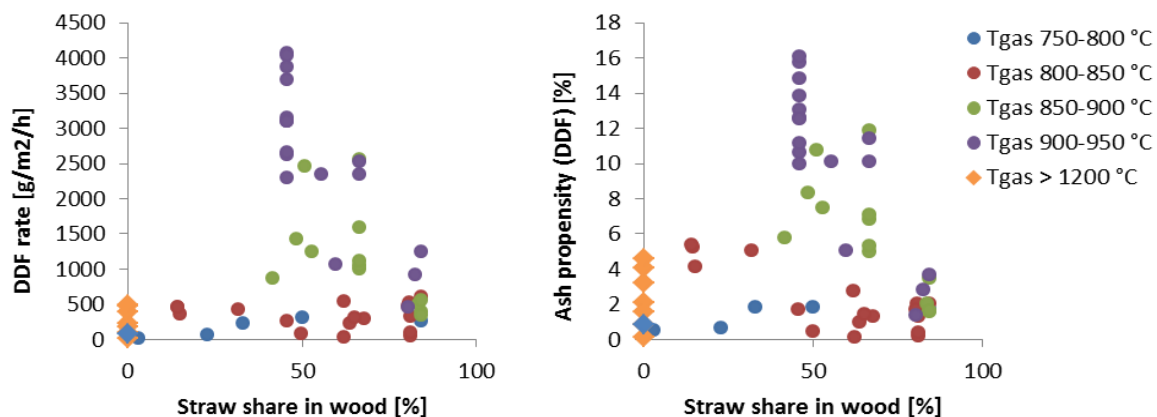

Figure 7: DDF rate (left figure) and ash propensity (right figure) as function of the straw share in wood for suspension firing. Colors indicate the flue gas temperature. Circles: Data from Amager [10] Diamonds: Data from Avedøre [22].

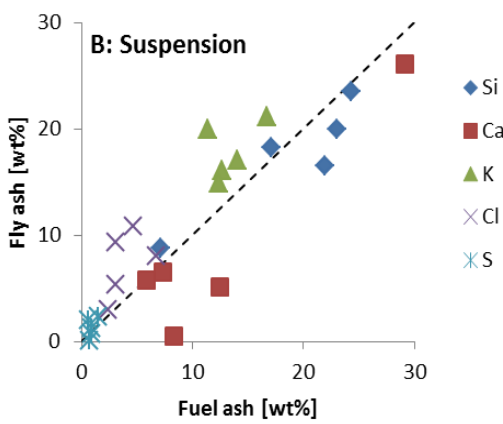
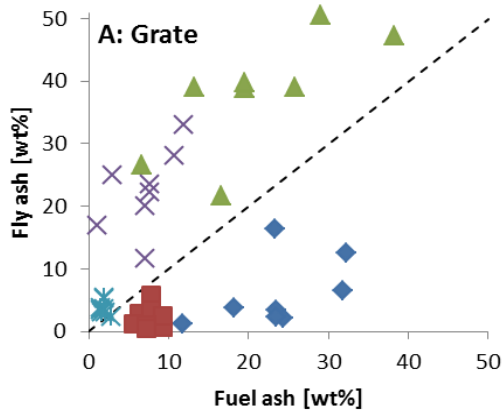

Figure 8: Fly ash composition vs. fuel ash composition. A: Grate; fuels are straw from refs [7,16]. B: Suspension. Fuels are various straw/wood mixtures from refs [10,11,18].

The differences of the chemical composition results in different melting behaviors and thereby stickiness of the fly ash particles as well as of the formed deposits. Zhou [23] has presented empirical correlations for predicting the melt fraction of ashes as function of temperature based on the chemical analysis of the ash. These correlations have been used to calculate melting curves of fly ashes of straw from grate and suspension firing and for a fuel ash of wood. The result is seen in Figure 9.

It is seen that there is significant difference in the melt fraction of straw fly ashes in the temperature range 650-1300 °C, which can partly explain the difference in the deposition behavior observed for grate- respectively suspension-fired units. For comparison a woody fuel ash is included. It is seen that this fuel ash has lower melt fractions than the straw fly ashes.

Furthermore, the differences in ash deposition propensity may be caused by physical form of the fly ashes, which may be quite different in the two combustion systems. In grate fired units K and Cl dominates the fly ash composition and is expected to be found as KCl vapors or aerosols. In suspension fired units K and Si dominates and are mainly found as solid K-silicates.

The deposits are formed from the fly ash. In the following it will be reviewed how the chemical transformations occur in the two combustion systems based on the chemical analysis of fuels, fly ash and deposits collected in the measuring campaigns.

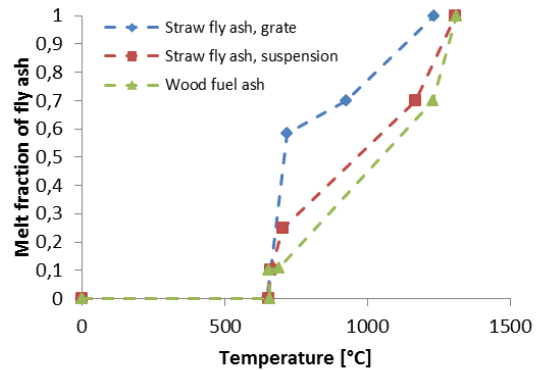

Figure 9: Melting curves of fly ashes from grate and suspension firing of straw along with a melting curve for wood fuel ash. Ash compositions from ref [11].

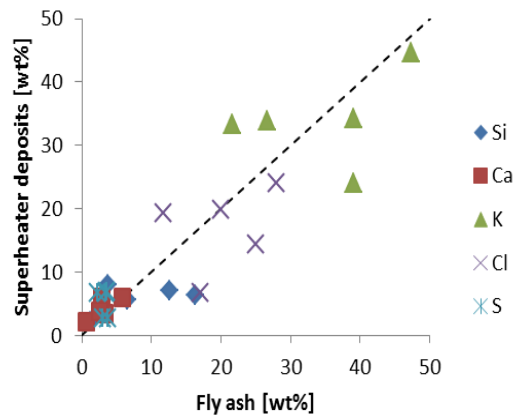
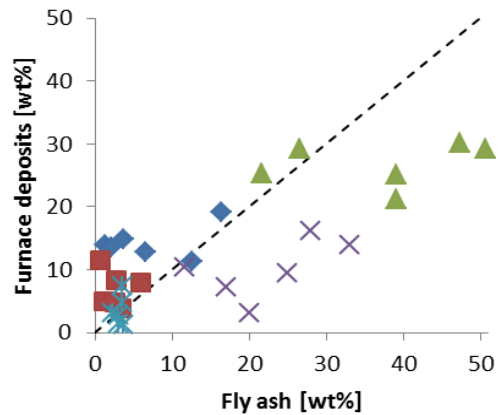

Figure 10: Deposit probe compositions vs. fly ash compositions in grate fired boilers. A: In the furnaces (835-873 °C). B: Near the superheaters (650°C). Data from Haslev and Slagelse [7].

In the measuring campaign conducted in Haslev and Slagelse [7], the fuel and fly ash were sampled in each test along with deposits collected in two positions in the boiler. In Figure 10, the fly ash composition (also seen in Figure 8A) is compared to the compositions of the deposits formed in the furnace chamber at flue gas temperatures of 835 °C or 873 °C, and to the deposits collected near the superheaters at flue gas temperatures near 650 °C.

It is seen that in the furnaces (at high temperatures),

the deposits contain more Ca and Si and less K and Cl compared to the fly ash. At the probes near the superheaters, where the flue gas temperature is 650 °C, the deposits chemical composition resembles that of the fly ash. There is thus a shift in the deposition behavior with flue gas temperature.

This has been explored further by calculation of an enrichment factor for each element;

$$\text{Enrichment factor} = \frac{\text{wt\% in deposit}}{\text{wt\% in fuel ash}}$$

In the calculation of the enrichment factor, the fuel ash composition is used rather than the fly ash composition, since the fuel ash composition has been examined in more measuring campaigns and is often known to a larger extent than the fly ash composition. It

should be kept in mind when examining these data, that the enrichment factor is based on two ash splits; one split occurring in the combustion zone (especially for grate-firing) and one split occurring during deposit buildup, where the elements behave differently.

The enrichment factors for the five main ash forming elements in grate-firing of biomass are seen as function of flue gas temperature in Figure 11. It is seen that for Si and Ca, the enrichment ratio is low at the low temperatures and approaches an enrichment factor around 1 at higher temperatures, except for the deposits at the rear of the probe. A possible explanation for this behavior is that at higher temperatures, the melt fraction of ash particles will increase and the particles will be more prone to sticking to the probe surface than at lower temperatures.

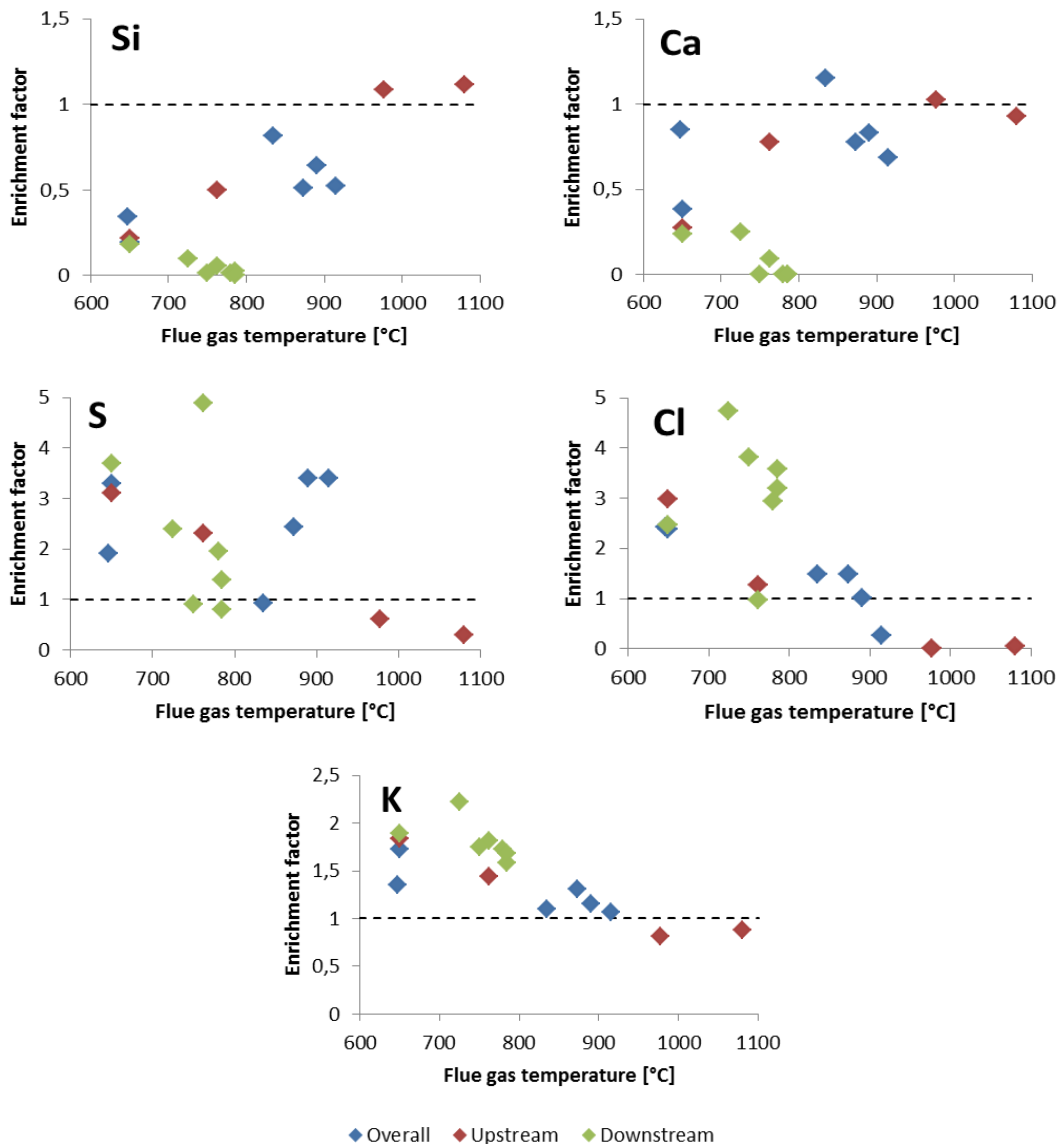

Figure 11: Enrichment factors for the five main ash forming elements as function of flue gas temperature for deposits collected in grate fired boilers; Haslev, Slagelse, Avedøre and Ensted [7,15,16]. The colors indicate at which position on the probe, the deposits are collected; upstream means the half circle of the probe facing the flue gas direction.

For Cl, the enrichment factor is high at low temperatures and then decrease with increasing flue gas temperatures. It seems that deposits formed at high flue gas temperatures can be expected to be depleted of chlorine. A similar behavior is observed for sulfur, although with a much larger scattering of data. The enrichment factors for potassium are between 1 and 2 at the low flue gas temperatures. At higher temperatures the K enrichment factor approaches 1.

The enrichment factors have also been calculated for the deposits collected on probes in suspension fired boilers. The results are seen in Figure 12. It is seen that the influence of the flue gas temperature on the enrichment factors is the same as observed for deposits from the grate fired units in Figure 11. The main differences observed among the enrichment factors from the two combustion technologies are that the enrichment factors of K, Cl and S are higher in suspension-fired units at the low temperatures. Furthermore, the downstream deposits can be expected to contain some Si and Ca, contrary to deposits from grate fired units. These

differences can all be related to the higher entrainment of ash in suspension firing.

The influence of temperature on the deposits chemistry can be explained by the deposit mechanisms involved in deposit buildup. The flue gas contains KCl and K_2SO_4 , which may condense on the cold probe. The rate of condensation is determined by the difference in the flue gas concentration and the saturation concentration of KCl or K_2SO_4 near the surface. At high temperatures the saturation concentration is high and the gaseous species will not be transported toward the surface. The surface temperature of the deposit on the probe is determined by the flue gas temperature after some initial build-up has occurred. This may explain the lower enrichment ratios of K, Cl and S observed at higher temperatures. The saturation concentration of KCl increases drastically around 700 °C, while the saturation concentration of K_2SO_4 is low up to temperatures around 1100 °C [24]. This explains the differences observed between Cl and S, as these two elements are mainly transported to the deposits as KCl and K_2SO_4 .

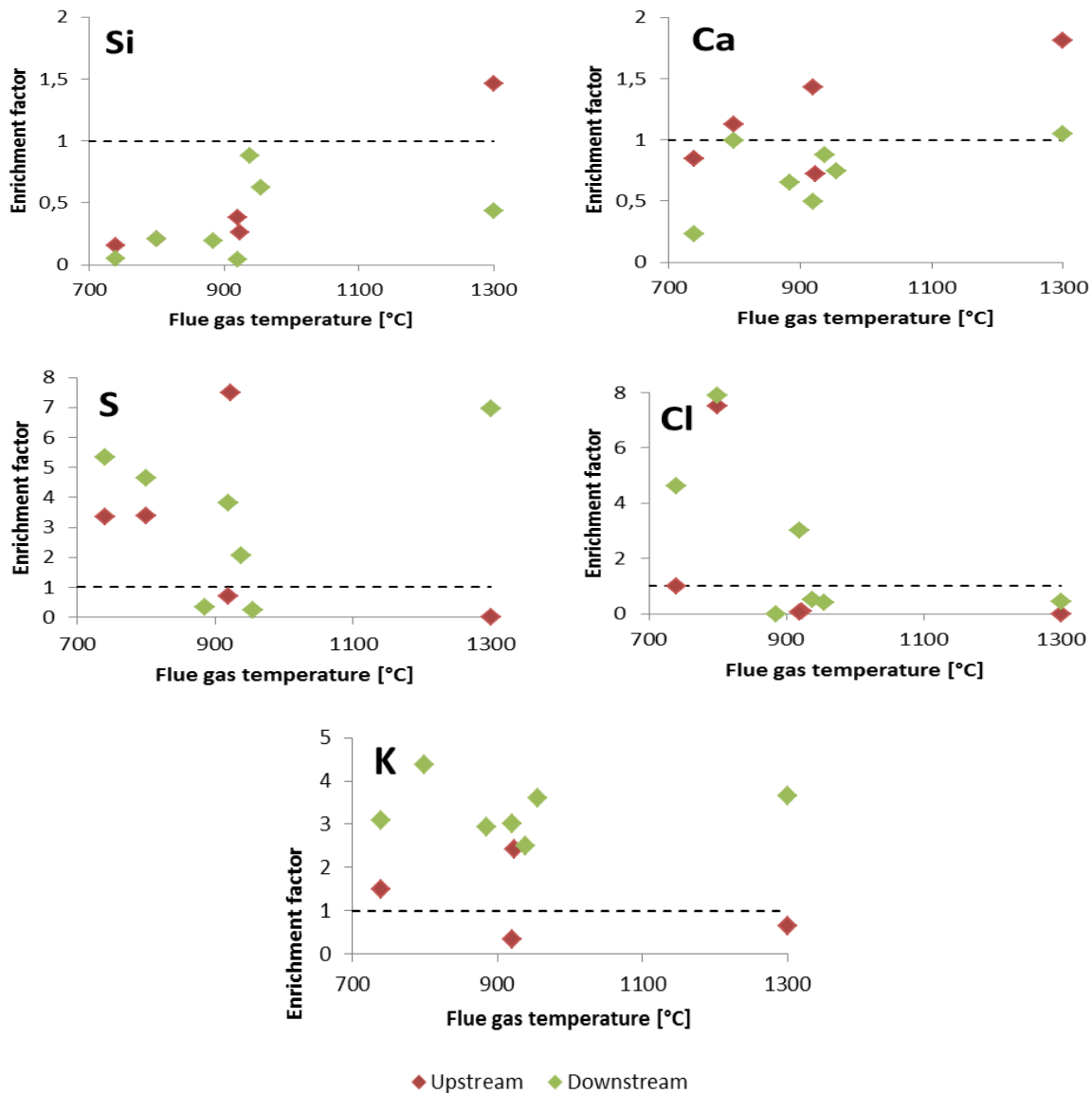

Figure 12: Enrichment factors for the five main ash forming elements as function of flue gas temperature for deposits collected in suspension fired boilers [18,20,22]. The colors indicate at which position on the probe, the deposits are collected; upstream means the half circle of the probe facing the flue gas direction.

The increase in the enrichment factors of Ca and Si with increased flue gas temperatures can be explained by a higher melt fraction of the fly ash particles and the deposit surface at high temperatures. When the melt fraction increases, the particles are more prone for sticking on the probe surface when the particles coincide with the surface by inertial impaction. The higher flue gas temperature also influences the surface temperature of the formed deposits, leading to a higher melt fraction and stickiness of the deposit surface.

It has thus been found that the flue gas temperature influences both the rate of deposit formation and the deposits chemistry. As the flue gas temperature increases the particles and the deposit surface will have an increased melt fraction. This leads to an increased deposit build-up by inertial impaction. As it is the large fly ash particles which are transported by inertial impaction, this mechanism is responsible for a large part of the deposit mass uptake. Thus, the main influence of an increased flue gas temperature is increased inertial impaction which leads to higher build-up rates and more Si and Ca in the deposits.

In one measuring campaign [15], the influence of varied probe temperature has been examined. The flue gas temperature was kept relatively constant within 700-800 °C, while the probe surface temperature was varied within 400-550 °C. It is found that neither the deposition rate nor the deposit chemical composition is varied with these variations in probe temperature, except for the chlorine content of the deposit, which seem to be lowered at higher probe temperature. The deposit patterns however changes with temperature; at 400 °C the deposit is uniform along the probe. At 500 and 550 °C a 'camel-back' like deposit was formed [15].

The influence of the probe temperature on deposit build-up is thus limited. It is however considered that the probe temperature may influence the very initial deposition, but this is considered to be of limited influence on the overall behavior.

The flue gas temperature rather than the probe temperature determines the deposit buildup rate and deposit chemistry. The ability of the fly ash and aerosols to stick on the deposit surface is governed by the melt fraction of the surface, which is controlled by the deposit surface temperature, and thus the flue gas temperature

3.3 Shedding of deposits

Shedding of deposits has been examined in grate fired units in two measuring campaigns, both conducted at Avedøre [15,17]. In one measuring campaign the influence of flue gas temperatures in the range 800-1100 °C is observed with a constant probe temperature at 500 °C [17]. It is found that at these conditions the flue gas temperature governs the state of the deposit; at 900 °C and below, the deposits are solid, porous and particle rich. The build-up rate exceeds the shedding rate, with shedding only occurring by soot-blowing. When the temperature increases to around 1000 °C, the deposits contain both melt and solid particles. The rate of deposit formation and shedding are in the same order of magnitude. At 1100 °C or above, the deposit surface layer is completely melted, and the deposits are rapidly removed as droplets [17].

In the other campaign conducted in the grate-fired plant the flue gas temperature is within 700-800 °C and the probe temperature is varied in the range 400-550 °C [15]. It is found that the probe temperature and the

exposure time influence the removability of the front deposit. Higher temperatures and long exposure times lead to deposits which are difficult to remove. This is considered to be due to sintering and thereby increased deposit-tube adhesion strength. The mechanism of removal is in all cases brittle fracture and debonding induced by the sootblower. For the deposits at the downstream side of the probe it was found that these were melted in all cases, except at the low temperature, 400 °C. However, the downstream deposits were easily removed, except those at the high temperature, 550 °C [15]. As there are found to be differences in the upstream and downstream deposit chemical composition, it seems that both the temperature and the chemistry of deposits influence the strength and removability of deposits.

For suspension fired boilers, shedding has been examined for straw/wood mixtures [25], for wood [22] and for wood with coal ash addition [21; 22].

In the measuring campaign with straw/wood mixture as fuel [25], the influence of probe temperature (500 or 600 °C) and exposure time is examined. It is found that an increase of the probe temperature from 500 °C to 600 °C lowers the shedding rate, both for natural and sootblower induced shedding and that shedding occurs by debonding. The influence of exposure time has been examined by tracking the Peak Impact Pressure (PIP) of a sootblower jet needed for removal of deposits. At 500 °C probe temperature, the needed PIP increases with exposure time. Contrary, at 600 °C probe temperature, the exposure time is less significant and the deposits are difficult to remove even at short residence times.

It is considered that at the high temperature partial melting of the deposits occur and thereby the adhesion strength is enhanced. It is furthermore considered that at the high temperature the deposit layers are thicker and the upstream and downstream layers are connected, making the debonding more difficult [25].

This latter consideration is supported by the observation, that when the deposit mass on the probe increase, the percentage of deposit removed in a shedding event decrease. It is generally observed that the shedding rate is lower than the DDF-rate, which implies that more and more deposits are attached to the probe and less and less can be removed at time goes by. This is found for both natural shedding and soot-blower induced shedding [25].

Shedding observations has also been made for suspension-firing of wood, where probe observations with a 550 °C probe has been made in two positions in the Avedøre boiler [22]. At these positions the flue gas temperatures are 800 °C and 1300 °C. At the location with flue gas temperature 800°C the deposit mass uptake is slow. After some time, the deposit mass on the probe becomes constant, indicating equilibrium between deposition and shedding rates. The type of shedding at this position is not identified, but due to insignificant mass loss, it is probably not by debonding. At the 1300 °C location, the deposit buildup is fast and ended by a sudden shedding event – with almost complete removal of the deposit by debonding [22]. It can thus be concluded that the shedding behavior is quite different from what is observed with the straw/wood mixture as fuel.

The effect of adding coal ash to the wood in suspension fired boilers has also been tested [21,22]. It is found that the overall deposition and shedding patterns are similar at the two positions with flue gas temperatures

800 and 1300 °C with the addition of coal ash. It is however observed that at the 800 °C position, the constant amount of deposit obtained is lower than observed for the pure wood firing. At the position with flue gas temperatures around 1300 °C, it is found that the build-up/complete shedding cycle is shorter than observed for wood firing. Without coal ash addition the cycle is approximately 10 hours, whereas adding coal ash leads to a cycle of approximately 2 hours [22]. The coal ash addition leading to increased amounts of aluminosilicates thus has a positive effect.

From the above mentioned shedding studied, it seems that both fuel composition and temperature are important parameters in the shedding behavior of deposits.

The compression strength of fly ash pellets from suspension firing of straw and from grate firing of straw has been compared in lab scale studies [15]. Fly ash pellets are heat-treated at different temperatures for 4 hours before the compression strength is measured. The results are seen in Figure 13.

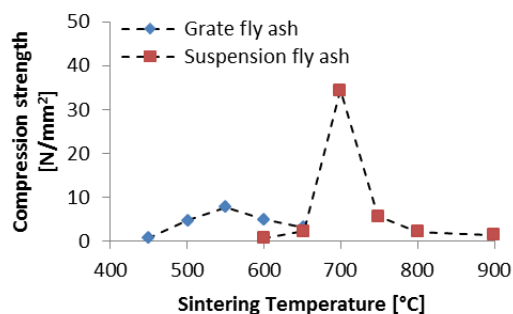

Figure 13: Compression strength as function of sintering temperature for two fly ashes from straw combustion [15].

It is seen that in both cases the compression strength first increases, then decreases as temperature is increased. The increase of compression strength is associated with sintering of the ash pellets, while the decrease in strength is associated with the formation of pores, due to evaporation of some elements. This behavior may not apply completely to real deposits, where long exposure times, additional deposition and possibly collapse of deposits may alter the sintering behavior.

However, it is seen that for the fly ash from suspension-firing the onset of strength increase is high (650 °C) compared to that of fly ash from grate-firing of straw (450 °C). The examined fly ash from suspension firing has a high content of Si and Ca, and a low content of K and Cl compared to the fly ash from grate-firing [15]. It is thus seen that both the chemical composition and the local temperature influence the deposit strength.

The sintering temperature has been compared to results from other laboratory studies. It is found, that wood ashes with higher contents of Si and Ca have even higher sintering temperatures, above 780 °C, while coal ashes have sintering temperatures in the range 920-1010 °C [15].

As the flue gas temperature influences both the deposit temperature and the chemical composition of the deposits, it thus has both a direct and an indirect influence on the sintering of deposits, and thus on the shedding mechanism and rate.

4 CONCLUSION

Within the last 15 years several measuring campaigns with focus on deposition behavior have been conducted at full-scale power plants firing biomass in Denmark. These measuring campaigns have been reviewed in this work. The focus of the review is the obtained experiences on deposit formation, shedding and chemistry.

A general conclusion is that the flue gas temperature is an important parameter in the deposit behavior of biomass-fired boilers. It is found that increases in the flue gas temperature of both grate and suspension fired boilers leads to increased deposition rates and altered chemical composition of the deposits formed. The increased rate of formation of deposits with increased temperature is considered to be caused by increased melt fractions of fly ash particles and of deposits surfaces. This leads to increased stickiness of the surfaces and thus increased capture efficiency of impacted particles. The impacted particles are mainly large (>10 µm) particles, containing Si and Ca. The increased rate of inertial impaction thus leads to increased contents of these elements in the deposits formed at high flue gas temperatures.

When comparing the two combustion technologies, grate- and suspension-firing, it is found that the rates of deposit formation are comparable, while the chemical composition of the fly ashes are quite different, even for the same type of fuel.

The differences in the entrainment of ash particles from the combustion zone to the flue gas lead to the observed differences in the chemical composition of the fly ashes. For grate fired units, the fly ash is dominated by K and Cl, probably in the form of KCl. This compound has a low melting temperature and will stick to surfaces of particles and deposits. A sticky surface of particles and deposits leads to a high propensity for ash deposition. For suspension fired units, the fly ash is dominated by Si, K and for woody fuels also Ca. The compounds formed from these elements have higher melting temperatures and particles will be less prone to sticking to surfaces upon impaction.

The shedding behavior is influenced by both probe surface temperature, flue gas temperature and deposits chemistry. The temperatures of both the probe and the flue gas influence the temperature gradients within the deposits, and thus the degree of sintering. The influence of temperature on the degree of sintering varies with the fuel type. It seems that increased contents of Si and Ca leads to increases in the sintering temperature, and thus to altered shedding behavior. However, the research within this area is limited and based on laboratory scale experiments, so no clear conclusion on the effect of temperature or the chemistry in full-scale applications can be obtained.

Coal ash has been added to woody biomass in suspension firing at Avedøre to possibly limit the deposition behavior of biomass. It is observed that the coal ash addition leads to frequent occurrences of complete shedding events, and the deposit buildup of the biomass ash is thereby minimized. However, as it is planned to substitute all coal combustion with biomass, this solution is only temporarily available.

5 REFERENCES

- [1] Bryers, R.W. Fireside slagging, fouling, and high-temperature corrosion of heat-transfer surface due to impurities in steam-raising fuels. *Prog. Energy Combust. Sci.* 1996, Vol. 22, pp. 29-120.
- [2] Baxter, L.L. Ash deposition during biomass and coal combustion: A mechanistic approach. *Biomass and Bioenergy.* 1993, Vol. 4, 2, pp. 85-102.
- [3] Zbogar, A.; Frandsen, F.; Jensen, P.A.; Glarborg, P.; Shedding of ash deposits. *Progress in Energy and Combustion Science.* 2009, Vol. 35, pp. 31-56.
- [4] Centre for Biomass Technology, (CBT). *Straw for Energy Production - Technology - Environment - Economy.* s.l. : Report, Ed: L. Nikolaisen, 1998.
- [5] <http://www.vattenfall.dk/da/amagervarket.htm>.
- [6] <http://www.dongenergy.com/da/forretningsaktiviteter/generation/elproduktion/pages/elproduktion.aspx>.
- [7] Jensen, P.A.; Stenholm, M.; Hald, P.; Deposit Investigation in Straw-Fired Boilers. *Energy & Fuels.* 1997, Vol. 11, pp. 1048-1055.
- [8] Michelsen, H.P.; Frandsen, F.; Dam-Johansen, K.; Larsen, O.H.; Deposition and high temperature corrosion in a 10 MW straw fired boiler. *Fuel Processing Technology.* 1998, Vol. 54, pp. 95-108.
- [9] Hansen, L.A.; Nielsen, H.P.; Frandsen, F.J.; Dam-Johansen, K.; Hörlyck, S.; Karlsson, A.; Influence of deposit formation on corrosion at a straw-fired boiler. *Fuel Processing Technology.* 2000, Vol. 64, pp. 189-209.
- [10] Bashir, M.S.; Jensen, P.A.; Frandsen, F.; Wedel, S.; Dam-Johansen, K.; Wadenbäck, J.; Pedersen, S.T.; Suspension-Firing of Biomass. Part 1: Full-Scale Measurements of Ash Deposit Build-up. *Energy & Fuels*, in press. 2012.
- [11] Bashir, M.S.; Jensen, P.A.; Frandsen, F.; Wedel, S.; Dam-Johansen, K.; Wadenback, J.; Pedersen, S.T. Ash transformation and deposit build-up during biomass suspension and grate firing: Full-scale experimental studies. *Fuel Processing Technology.* 2012, Vol. 97, pp. 93-106.
- [12] Van Loo, S; Koppejan, J.; *The Handbook of Biomass Combustion and Co-firing.* s.l. : Earthscan, 2008.
- [13] Nielsen, H.P. *Deposition and High-Temperature Corrosion in Biomass-Fired Boilers.* s.l. : Ph.D. Thesis, Department of Chemical Engineering, Technical University of Denmark, 1998.
- [14] Jensen, P.A.; Frandsen, F.J.; Hansen, J.; Dam-Johansen, K.; Henriksen, N.; Hörlyck, S.; SEM Investigations of Superheater Deposits from Biomass-Fired Boilers. *Energy & Fuels.* 2004, Vol. 18, pp. 378-384.
- [15] Jensen, P.A.; Zhou, H.; Zbogar, A.; Hansen, J.; Frandsen, F.J.; Glarborg, P.; Madsen, B.; Stang, H.; Final Report - Ash Deposit Formation and Removal in Biomass-fired Boilers. *Fundamental Data Provided with Deposit Probes.* s.l. : Energinet.dk PSO project 4106 (CHEC Report R0603), 2006.
- [16] Hansen, J.; Jensen, P.A.; Glarborg, P.; Deposit probe measurements in the Avedøre and Ensted straw fired grate boilers. s.l. : CHEC Report R0705 (PSO Project 4792), 2007.
- [17] Zbogar, A.; Jensen, P.A.; Frandsen F.J.; Hansen, J.; Glarborg, P.; Experimental Investigation of Ash Deposit Shedding in a Straw-Fired Boiler. *Energy & Fuels.* 2006, Vol. 20, pp. 512-519.
- [18] Skrifvars, B.-J.; Laurén, T.; Hupa, M.; Korbee, R.; Ljung, P. Ash behavior in a pulverized wood fired boiler - a case study. *Fuel.* 2004, Vol. 83, pp. 1371-1379.
- [19] Tobiasen, L.; Skytte, R.; Pedersen, L.S.; Pedersen, S.T.; Lindberg, M.A. Deposit characteristic after injection of additives to a Danish straw-fired suspension boiler. *Fuel Processing Technology.* 2007, Vol. 88, pp. 1108-1117.
- [20] Jensen, P.A.; Dall'Orta, M.; Lin, W.; Clausen, S.; Hansen, J.; Simonsen, P.; Berg, M.; Jensen, A.D.; Measurements on the 800 MWth Avedøre oil, gas and wood co-fired suspension boiler - Analysis of emission, burnout, deposit and FTIR measurements from April 2005. s.l. : Energinet.dk PSO project 6526 (Appendix E), 2008.
- [21] Bashir, M.S.; Jensen, P.A.; Frandsen, F.; Wedel, S.; Dam-Johansen, K.; Suspension-firing of wood with coal ash addition: Probe measurements of ash deposit build-up at Avedøre Power Plant (AVV2). s.l. : CHEC Report, 2012.
- [22] Wu, H.; Bashir, M.S.; Jensen, P.A.; Glarborg, P.; Frandsen, F.J.; Full-scale deposition measurements at Avedøre Power Plant unit 2 during suspension-firing of wood with and without coal ash addition. s.l. : CHEC Report, 2012.
- [23] Zhou, H.; Jensen, P.A.; Frandsen, F.J.; Dynamic mechanistic model of superheater deposit growth and shedding in a biomass fired grate boiler. *Fuel.* 2007, Vol. 86, pp. 1519-1533.
- [24] Knacke, O., Kubaschewski, O. and Hesselmann, K. *Thermochemical Properties of Inorganic Substances.* 2nd. s.l. : Springer-Verlag, 1991.
- [25] Bashir, M.S.; Jensen, P.A.; Frandsen, F.; Wedel, S.; Dam-Johansen, K.; Wadenbäck, J.; Pedersen, S.T.; Suspension-firing of biomass. Part 2: Boiler measurement of ash deposit shedding. *Energy & Fuels*, submitted. 2012.

9 ACKNOWLEDGEMENTS

This work is part of the GREEN research center (Power Generation from Renewable Energy) funded by the Danish Strategic Research Center. The work is conducted in collaboration between Danish Technical University, DONG Energy Power and Vattenfall A/S.

