



Development and evaluation of methods for recovery of Noroviruses from food, water and air

Uhrbrand, Katrine; Hedlund, Kjell-Olof; Myrmel, Mette; Christensen, Laurids Siig

Publication date:
2012

Document Version
Publisher's PDF, also known as Version of record

[Link back to DTU Orbit](#)

Citation (APA):

Uhrbrand, K., Hedlund, K-O., Myrmel, M., & Christensen, L. S. (2012). Development and evaluation of methods for recovery of Noroviruses from food, water and air. Kgs. Lyngby: Technical University of Denmark (DTU).

DTU Library

Technical Information Center of Denmark

General rights

Copyright and moral rights for the publications made accessible in the public portal are retained by the authors and/or other copyright owners and it is a condition of accessing publications that users recognise and abide by the legal requirements associated with these rights.

- Users may download and print one copy of any publication from the public portal for the purpose of private study or research.
- You may not further distribute the material or use it for any profit-making activity or commercial gain
- You may freely distribute the URL identifying the publication in the public portal

If you believe that this document breaches copyright please contact us providing details, and we will remove access to the work immediately and investigate your claim.

**DEVELOPMENT AND EVALUATION OF
METHODS FOR RECOVERY OF NOROVIRUSES
FROM FOOD, WATER AND AIR**

PHD THESIS BY KATRINE UHRBRAND



Division of Food Microbiology
National Food Institute
Technical University of Denmark

January 2012

Preface and acknowledgements

The present PhD thesis summarises my work as a PhD student at the Division of Food Microbiology, National Food Institute, Technical University of Denmark. The work was carried out as part of the Nordic project “Reducing the risk from foodborne viruses in the Nordic countries” funded by the Nordic Joint Committee for Agricultural Research (grant NKJ-130).

The main supervisor of the project was Senior Scientist Laurids Siig Christensen, Division of Food Microbiology, National Food Institute, Technical University of Denmark. Co-supervisors were Associate Professor Mette Myrmel, Department of Food Safety and Infection Biology, Norwegian School of Veterinary Science and Chief Microbiologist Kjell-Olof Hedlund, Center for Microbiological Preparedness, Swedish Institute for Infectious Disease Control.

I wish to thank all the persons that have contributed in one way or another to my experimental work and in writing this thesis. In this connection I would sincerely like to thank my main and co-supervisors for their help and guidance during the project. A particular heartfelt thank goes to my teamleader Anna Charlotte Schultz for fruitful collaboration, help and support. Sincere thanks also go to Anders Hay Sørensen for his review of the thesis. In addition, I would like to acknowledge Senior Scientist Anne Mette Madsen at the National Research Center for the Working Environment and Associate Professor Börje Sällergren at the Institute of Environmental Research, Dortmund University of Technology, whom I have had the pleasure of collaborating with during my PhD.

Finally, thanks to all of my colleges for making every day special. Special thanks to Grethe, Lille, Pittemut, Anders and Martin for being who you are -a girl couldn't wish for at better daily antidote to PhD-induced despair☺. Moreover, thanks to Biografklubben for social events along the way. Also huge thanks to all my wonderful friends, especially Leise and Vinni, for providing fun times when I needed a break. And above all, I wish to thank to my family for their everlasting love and support.

Abbreviations

AdV	Adenovirus
AGI	All-glas impingers
CaCV	Canine calicivirus
cDNA	Complementary DNA
COPII	Coat protein II
CTAB	Cetyltrimethylammonium bromide
DNA	Deoxyribonucleic acid
EAC	External amplicifaction control
EIA	Enzyme immunoassay
EMA	Ethidium monoazide
EV	Echovirus
FCV	Feline calicivirus
FUT	Fucosyltransferase
HAV	Hepatitis A virus
HBGA	Histo blood group antigen
HHP	High hydrostatic pressure
HUIS	High-intesity ultrasound
IAC	Internal amplification control
ID ₅₀	Infection dose 50%
IRES	Internal ribosomal entry site
LVS	Large volume samplers
LOD ₅₀	Llimit of detection 50%
MC ₀	Mengovirus
MNV	Murine norovirus
mRNA	Messenger ribonucleic acid
MS2	Bacteriophage MS2
NIP	Non-imprinted polymer
NoV	Norovirus
ORF	Open reading frame
PBS	Phosphate buffered saline
PCR	Polymerase chain reaction
PEG	Polyethylenglycol

pI	Isoelectric point
PMA	Propidium monoazide
PV	Poliovirus
PAA	Peroxyacetic acid
RNA	Ribonucleic acid
RT-PCR	Reverse transcriptase polymerase chain reaction
RV	Rotavirus
SNARE	SNARE attachment protein receptor
UV	Ultraviolet
VAP-A	Vesicle-associated membrane protein-associated protein A
VIP	Virus imprinted polymer
VIRADEL	Virus adsorption-elution
VLP	Virus-like particle
VP1	Major structural protein
VP2	Minor structural protein
WWTP	Wastewater treatment plant

Summary

Noroviruses (NoVs) are the principal cause of viral gastroenteritis worldwide. NoVs are extremely infectious with an estimated infectious dose 50% (ID₅₀) of 18 viral particles. Transmission of NoVs occurs via the faecal-oral route directly through person-to-person contact or indirectly via contaminated fomites, water and food. In recent years, numerous outbreak of NoV-associated gastroenteritis have been linked to the consumption of contaminated drinking water, shellfish and fresh produce. In addition, indications of transmission occurring through aerosol formation, especially following projectile vomiting, have been seen, but little is at present known about the possibility and extent of airborne transmission of NoVs.

To reduce transmission of NoV it is imperative to have efficient virus recovery methods available that can be used for routine analysis of the implicated matrices. However, currently no standardised procedures exist for this purpose. The aim of this PhD thesis was to develop and evaluate methods for recovery of NoV from shellfish and drinking water that could contribute to the work done towards finding suitable standardised methods. This was done through three studies, presented in manuscript I-III. Additionally, exposure to airborne NoV transmission and NoV decontamination of food surfaces were addressed in manuscript IV and V, respectively.

In manuscript I five methods were compared for the ability to qualitatively recover NoV GII and feline calicivirus (FCV) spiked in the digestive tissue of oysters and blue mussels. A method based proteinase K digestion followed by NucliSens miniMAG nucleic acid extraction was found to give the best performance. In a subsequent collaborative trial the method was found to robustly recover the NoV GI, NoV GII and HAV bioaccumulated in the both oysters and mussels. Consequently, the method was found to be a good candidate as a future qualitative standard for routine viral analysis of oysters and mussels.

The ability of a rapid method to recover NoV GI, NoV GII and adenovirus (AdV) from Nordic drinking water (tap water) of various types was evaluated in manuscript II. The method was based on filtering using a positively charged membrane followed by direct lysis of the virus adsorbed to the membrane. The average efficiency of the method to recover NoV GI (43±29%) and GII (45±24%) from drinking water was generally found to be better, or at least comparable, to previously published methods, suggesting that the method could be suitable for routine analysis. However, virus and water type were found to significantly affect the recovery.

As an alternative strategy for the recovery of NoVs from drinking water the feasibility of using virus imprinted polymers (VIPs) for capture and selective recognition of NoVs was investigated in manuscript III. Three VIPs targeted for murine norovirus (MNV), NoV GI and NoV GII, respectively, were synthesised and experiments to determine binding of the target viruses and a non-target AdV to the VIPs and to non-imprinted polymers (NIPs) were conducted. Unfortunately, a relative poor selective recognition and high degree of unspecific binding to the VIPs were observed. Thus, VIPs in their current form do not appear to be an optimal approach for recovery of NoVs from drinking water.

Aerosolisation of microorganisms may occur during treatment of wastewater. Therefore, the exposure to aerosolised NoVs and other bioaerosol components at a wastewater treatment plant (WWTP) was examined using personal samples in manuscript IV. NoVs were, for the first time, detected on a dust filter carried by a WWTP worker in concentrations that could pose an occupation risk. Because the workers at the WWTP had previously been found to have an increase frequency of acute gastrointestinal illness, consistent with NoV infection, our finding suggest that that airborne transmission of NoVs do indeed occur at the WWTP.

Finally, manuscript V evaluated the efficiency of a surface decontamination strategy based on combined treatment with steam and ultrasound to inactivate the NoV surrogates FCV, MNV and bacteriophage MS2. The steam-ultrasound treatment was found to be effective for decontamination of plastic surfaces with near complete inactivation observed after treatment for 1 or 3 s, depending on the NoV surrogate. However, steam-ultrasound treatment in its current form was found to be inappropriate for NoV decontamination of raspberries as only 1-log reduction of MS2 was achieved after treatment 1 s at which point unwanted loss in the texture of the raspberries were observed.

Sammendrag (Danish summary)

Norovirus (NoV) er den primære årsag til viral gastroenteritis på verdensplan. Med en estimeret infektiv dosis (ID_{50}) på 18 virus partikler er NoV ekstremt infektiøse. NoV smitter via den fækal-orale rute enten direkte via person-til-person kontakt eller indirekte gennem kontaminerede genstande, vand eller fødevarer. I de senere år er utallige udbrud af gastroenteritis blevet forbundet med indtagelse af NoV kontamineret drikkevand, skaldyr, grøntsager og bær. Endelig er der set indikationer på, at NoV kan smitte gennem luften via aerosoldannelse specielt i forbindelse med voldsomt opkast. Til trods for dette, eksisterer der til stadighed kun sparsom viden omkring risikoen for luftbåren smitte af NoV.

For at reducere spredning af NoV er det essentielt at have effektive virus oprensningmetoder til rådighed, der kan anvendes til rutinemæssigt at analysere for tilstedeværelsen af NoV i fødevarer og drikkevand. På nuværende tidspunkt findes der dog ingen standardiserede procedurer til dette. Formålet med nærværende Ph.d. afhandling var derfor at udvikle og evaluere metoder til at oprense og opkoncentrere NoV fra skaldyr og drikkevand for således at bidrage til processen med at finde velegnede standardiserede metoder. Dette blev gjort gennem tre studier, der er præsenteret i manuskript I-III. Endvidere belyser afhandlingen muligheden for luftbåren smitte af NoV og udforsker en mulig strategi til NoV dekontaminering af fødevareoverflader. Dette blev gjort i henholdsvis manuskript IV og V.

I manuskript I blev fem oprensningsmetoders evne til kvantitativt at genfinde NoV genogruppe II (GII) og feline calicivirus (FCV) tilsat væv fra fordøjelsesorganet i østers og blåmuslinger sammenlignet. Bedste resultat blev fundet med en metode baseret på proteinase K behandling og NucliSens miniMAG nukleinsyre ekstraktion. Metoden blev efterfølgende evalueret i en ringtest, hvor det blev demonstreret, at den kunne anvendes til robust at oprense og genfinde NoV GI, NoV GII and hepatitis A virus (HAV) bioakkumuleret i østers og blåmuslinger. Metoden menes derfor at være en velegnet som en fremtidig standard rutine metode til virus analyse af skaldyr.

I manuskript II blev en hurtigmetodes evne til at genfinde NoV GI, NoV GII og adenovirus (AdV) fra forskellige typer af Nordisk drikkevand evalueret. Metoden var baseret på filtrering med et positivt ladet filter efterfulgt af direkte lysering af vira på filteret. Med en gennemsnitlig genfindelsesprocent på 43 ± 29 for NoV GI og 45 ± 24 for NoV GII var metoden generelt bedre, eller som minimum sammenlignelig, med tidligere publicerede metode. Dette tyder

på at metoden kan være egnet til rutine analyser af drikkevand. Dog fandtes virus og vand type at have en signifikant effekt på virus genfindelsen.

Som en alternativ strategi til opkoncentrering af NoV fra drikkevand blev anvendeligheden af virus imprintede polymere (VIPs) til selektiv genkendelse og binding af NoV udforsket i manuskript III. Tre VIPs til selektiv binding af henholdsvis murine norovirus (MNV), NoV GI og NoV GII blev syntetiseret. Binding af target virus og non-target virus (AdV) til både VIPs og nogle non-imprintede polymere (NIPs) blev undersøgt. Relativ dårlig selektiv virus genkendelse og høj grad af uspecifik binding blev desværre observeret for de syntetiserede VIPs. VIPs i deres nuværende form menes derfor ikke at være anvendelige til opkoncentrering af virus fra drikkevand.

Aerosolisering af mikroorganismer kan finde sted i forbindelse med spildevandsrensning. Eksponering for aerosoliserede NoV og andre bioaerosol komponenter på et rensningsanlæg blev undersøgt med personbårne luftsamlere i manuskript IV. NoV blev for første gang nogensinde påvist på et støvfilter båret af en ansat på rensningsanlægget i koncentrationer, som potentielt kan medføre en erhvervsmæssig risiko. Da øget hyppighed af akutte mave-tarm problemer, matchende symptomerne på Roskildesyge, tidligere var rapporteret blandt de ansatte på rensningsanlægget, indikerer vores fund, at luftbåren smitte med NoV forekommer på rensningsanlægget.

Effektiviteten af damp-ultralydsbehandling til at inaktivere NoV surrogaterne FCV, MNV og bakteriofag MS2 blev evalueret i manuskript V. Damp-ultralydsbehandling var effektiv til virus dekontaminering af plast overflader med næsten komplet inaktivering efter behandling i 1 eller 3 s afhængig af typen af NoV surrogat. Derimod var damp-ultralydsbehandling i den nuværende form utilstrækkelig til NoV dekontaminering af hindbær. Behandling i 1 s medførte nemlig kun 1-log reduktion af MS2 og resulterede i uønsket tekstur ændring af hindbærrene.

Table of content

PREFACE AND ACKNOWLEDGEMENTS.....	I
ABBREVIATIONS	II
SUMMARY	IV
SAMMENDRAG (DANISH SUMMARY)	VI
TABLE OF CONTENT.....	VIII
1 OBJECTIVES AND OUTLINE OF THESIS.....	1
2 CHARACTERISTICS OF NOROVIRUS	4
2.1 CLASSIFICATION AND GENETIC DIVERSITY	5
2.2 GENOMIC ORGANISATION	6
2.3 TRANSLATION AND REPLICATION	7
2.4 FUNCTION OF NON-STRUCTURAL PROTEINS.....	8
2.5 THE NoV CAPSID PROTEIN.....	9
3 EPIDEMIOLOGY, CLINICAL ASPECTS AND IMMUNITY	12
3.1 TRANSMISSION OF NOROVIRUS.....	13
3.2 CLINICAL ILLNESS	14
3.3 HOST SUSCEPTIBILITY.....	15
4 VIRUS RECOVERY STRATEGIES	17
4.1 SAMPLE PREPARATION.....	18
4.1.1 <i>Virus concentration from water</i>	18
4.1.2 <i>Virus concentration from food</i>	24
4.1.3 <i>Sampling of viral aerosols</i>	26
4.1.4 <i>Nucleic acid Extraction</i>	29
4.2 VIRUS DETECTION	30
4.3.1 <i>Real-time RT-PCR assays for detection of NoV</i>	30
4.4 QUALITY CONTROL AND INTERPRETATION OF RESULTS	31
5 INACTIVATION OF NOROVIRUS	33
5.1 STABILITY OF NoV IN THE ENVIRONMENT	34
5.2. HEAT TREATMENT.....	35
5.3. HIGH HYDROSTATIC PRESSURE TREATMENT	37
5.4 OTHER TREATMENTS	39

6 MANUSCRIPT I 41

7 MANUSCRIPT II..... 51

8 MANUSCRIPT III 71

9 MANUSCRIPT IV..... 88

10 MANUSCRIPT V 97

11 SUMMARISING DISCUSSION AND PERSPECTIVES 104

 11.1 VIRUS RECOVERY FROM FOOD AND DRINKING WATER..... 105

 11.2 EXPOSURE TO AIRBORNE NOROVIRUSES..... 108

 11.3 NOROVIRUS DECONTAMINATION 109

 11.4 CONCLUDING REMARKS 110

12 REFERENCES 112

Chapter 1

Objectives and outline of thesis

1 Objectives and outline of thesis

Novoviruses (NoVs) are the primary etiological agent responsible for viral gastrointestinal disease in humans worldwide and has been estimated to be accountable for 65-80% of all outbreaks of gastroenteritis in industrialised countries (Donaldson et al., 2010; Fankhauser et al., 2002). NoVs are excreted in high concentrations in faeces of infected persons and are primarily transmitted by the faecal-oral route, although transmission through airborne droplets also occurs (Atmar, 2010; Koopmans and Duizer, 2004). The infectious dose of NoV is very low and only a few virus particles present in food or water are necessary to seed an outbreak (Teunis et al., 2008). Therefore there is an urgent need for efficient methods to recover viruses from food, water and environmental samples.

The aims of the present PhD project was to: (i) develop new and evaluate existing methods for recovery of NoV and other enteric viruses in food (shellfish) and water that can be used for routine analysis and outbreak investigations; (ii) examine the exposure to airborne NoVs at a wastewater treatment plant in order to contribute with new understanding of the extent of airborne NoV transmission; (iii) evaluate a new steam-ultrasound method for NoV decontamination on food surfaces.

The thesis consists of 11 additional chapters. **Chapter 2** contains a general characterisation of norovirus including a description of its classification, phylogeny, genomic organisation and replication strategy. **Chapter 3** focuses on transmission and clinical aspects of NoV infections. **Chapter 4** presents available strategies for recovery of NoV from food, water and air. **Chapter 5** describes inactivation strategies for NoV. The results obtained in this PhD are presented in **Chapter 6** to **Chapter 10**. **Chapter 6** contains manuscript I “Evaluation of a rapid method for recovery of norovirus and hepatitis A virus from oysters and blue mussels” that has been published in *Journal of Virological Methods*. **Chapter 7** contains manuscript II “Inter-laboratory evaluation of a rapid method for recovery of norovirus and adenovirus from various types of Nordic drinking water”. This manuscript is currently in preparation for submission. **Chapter 8** contains manuscript III “Feasibility of using molecular imprinted polymers for norovirus recognition and capture” which is based on preliminary results. **Chapter 9** contains manuscript IV “Exposure to airborne noroviruses and other bioaerosol components at wastewater treatment plant in Denmark” that has been published in *Food and Environmental Virology*. **Chapter 10** contains manuscript V “Inactivation of norovirus surrogates on surfaces and raspberries by steam-ultrasound treatment” that has been published in *Journal of Food Protection*. **Chapter 11** contains discussion,

perspectivation and conclusion that summarised the results obtained in the manuscripts. **Chapter 12** contains the references cited in chapters 1-5 and chapter 11.

Chapter 2

Characteristics of norovirus

2 Characteristics of norovirus

2.1 Classification and genetic diversity

NoVs are a group of small (~38 nm) non-enveloped, icosahedral viruses, having a positive-sense, single-stranded RNA genome with a length of 7.5-7.7 kilobases (Atmar, 2010; Donaldson et al., 2008). NoVs belong to the genus *Norovirus* (previously referred to as “Norwalk-like viruses” or “Small-round structured viruses”) of the family *Caliciviridae* (Green et al., 2000).

The *Norovirus* genus can be divided into five genogroups based on sequence similarity. Within genogroups, strains can be further divided into genotypes, or genetic clusters, on the basis of the amino acid sequence of the entire major capsid protein (Zheng et al., 2006). Genogroups are designated by a capital “G” and a Roman numeral and genotypes are designated by an Arabic numeral. Furthermore strains are commonly named after the location of the outbreak where they were first found. GI, GII, GIII, GIV and GV consist of at least 9, 19, 2, 1 and 1 genotypes, respectively (Figure 1) (Atmar, 2010). The NoV strains that infect humans are found in GI, GII and GIV, with GI and GII being the most important. GII also contains porcine strains (GII.11, GII.18 and GII.19) and GIV contains strains infecting feline and canine species (GIV.2). GIII and GV viruses infect bovine and murine species, respectively. Although a human GII.4 strain has been shown to be able to infect gnotobiotic pigs and calves (Cheetham et al., 2006; Souza et al., 2008), NoVs tend to be species specific and no infections of humans with animal strains have to date been identified in humans (Atmar, 2010).

The NoV strains are antigenically and genetically diverse due to a hypervariable region located in the capsid gene. Comparison of the full-length major capsid amino acid sequence of 164 NoV strains demonstrated that the five genogroups diverged with 45-60%, while sequences within a genetic cluster differed with 14-44%. This is a much higher level of diversity than seen for other plus-sense single-stranded RNA viruses (Zheng et al., 2006). The great diversity of strains is attributed both to the accumulation of point mutations associated with errorprone RNA replication and to recombination between related viruses (Glass et al., 2009).

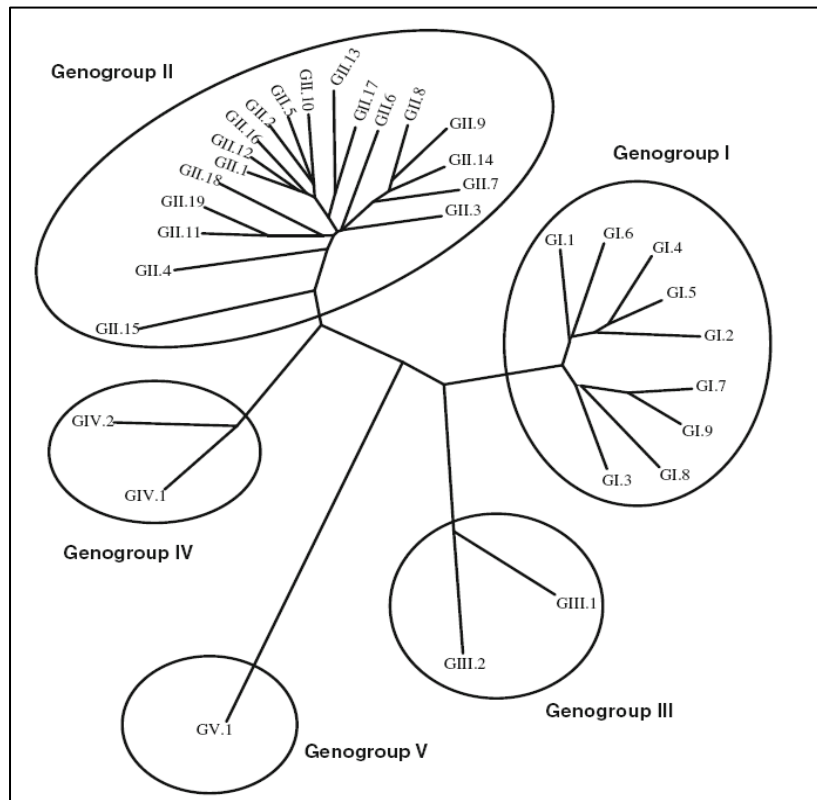

Figure 1. Phylogenetics of noroviruses based on the capsid protein. The Norovirus genus is divided into five genogroups (GI-GV), which each contains from 1 to 19 different genotypes. GIII and GV strains have only been found in animals, while GI, GII and GIV strains primarily infect humans (Atmar, 2010).

2.2 Genomic organisation

The NoV genome encodes three open reading frames (ORF) and is protein-linked at the 5' end and polyadenylated at the 3' end (Figure 2). ORF1 is the largest of the ORFs and encodes a polyprotein precursor of approximately 200 kDa that is cleaved post-translationally by the viral protease (PRO) into mature nonstructural proteins required for virus replication. The coding order in ORF1 proceeds N to C terminus, p48, NTPase, p22, VPg, PRO, and POL. ORF2 encodes the major structural protein VP1 that forms the capsid, and ORF3 encodes the minor structural protein VP2 (Atmar, 2010; Hardy, 2005). ORF1 and ORF3 are located in reading frame 3 of the cDNA, whereas ORF2 is in reading frame 2 (Jiang et al., 1993).

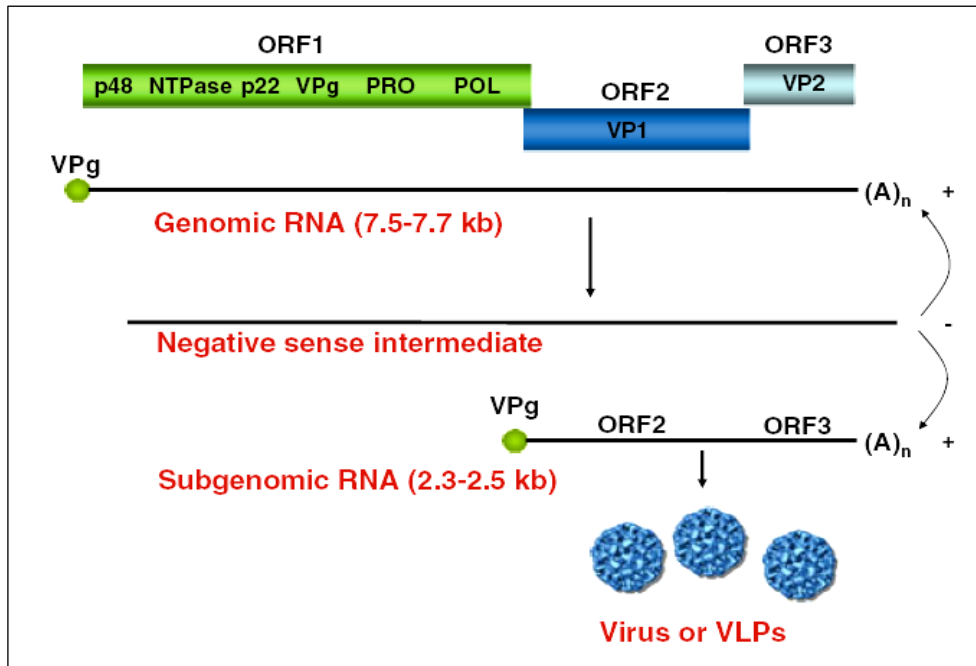

Figure 2. Norovirus genomic organisation and replication strategy. Norovirus is a positive strand RNA virus with three open reading frames (ORFs) encoding two structural proteins, VP1 and VP2, and a large polyprotein from which non-structural proteins are produced by proteolytic cleavage. Replication takes place through a negative sense intermediate, from which the genomic RNA and subgenomic RNA encoding the structural proteins are produced (Atmar, 2010)

2.3 Translation and replication

In the host cell, the NoV genome is used directly as messenger RNA (mRNA) for translation of the non-structural polyprotein precursor encoded by ORF1. After translation of the genomic NoV RNA into the non-structural proteins replication of the NoV genome will occur (Figure 2). Virus replication takes place through a negative sense intermediate from which both positive sense genomic RNA and a positive strand subgenomic RNA containing ORF2 and ORF3 are produced (Atmar, 2010). The replication is catalysed by the RNA-dependent RNA polymerase (POL) made in the process by translation and cleaving of the polyprotein encoded in ORF1.

Subgenomic RNA transcribed from the genomic RNA serves as a template for the translation of the structural proteins VP1 and VP2. VP2 is believed to be regulated relative to VP1, with the termination codon of VP1 being critical for the translation of VP2 (Hardy, 2005). Package of NoV genomic RNA into virus particles has been found only to occur when genomic RNA is co-expressed with subgenomic RNA. The signal for packaging of genomic RNA into virions has

therefore been proposed to reside in the ORF1 region and perhaps require the non-structural proteins (Asanaka et al., 2005).

2.4 Function of non-structural proteins

Little is still known concerning the function of the ORF1 proteins during NoV replication. The VPg, PRO, and POL proteins are best characterized, while only few data exist regarding the function of p48, NTPase and p22, and much of what is known has been inferred from studies of homologous proteins from related viruses (Hyde and Mackenzie, 2010).

The VPg protein is covalently linked to the 5' end of genomic and subgenomic mRNA and is thought to be involved in translation initiation. Most cellular mRNAs are translated by a cap-dependant mechanism driven by protein-protein and protein-RNA interactions between initiation factors (eIF) and cap-mRNA. The cap-dependant translation is initiated by a binding of the eIF4F complex consisting of eIF4E, eIF4G and eIF4A to the 5' end 7-methylguanosine cap structure on the mRNA, which then is recognised by the ribosomal subunit involved in scanning for the AUG start codon for protein synthesis (Daughenbaugh et al., 2006). NoV lack this cap-structure. Instead VPg has been proposed to function in ribosome recruitment to the viral RNA by interaction with the translation initiation factors as VPg protein has been shown to interact directly with eIF3 and eIF4E (Daughenbaugh et al., 2003; Daughenbaugh et al., 2006; Goodfellow et al., 2005). Furthermore, VPg has been found to inhibit cap-dependent and internal ribosomal entry site (IRES)-dependent translation (Daughenbaugh et al., 2003). Finally, it has been suggested that VPg may be involved in VPg-protein-primed initiation of replication of polyadenylated genomic RNA (Rohayem et al., 2006).

The cleaving of the translated polyprotein is made by the viral protease PRO encoded in OFR1. PRO belongs to a family of proteinases that folds into a bilateral beta sheet structure and it contains a functional catalytic dyad comprised of His30 and Cyst139 (Kuyumcu-Martinez et al., 2004; Someya et al., 2002). In addition to cleaving of the polyprotein, PRO has been reported to play a role in down-regulation of host mRNA in infected cells by cleaving the poly(A)-binding protein involved in binding of the translation initiation factor eIF4G to the poly(A)-tail of the host mRNAs in order to synthesize viral proteins more effectively (Kuyumcu-Martinez et al., 2004).

The function of the non-structural N-terminal protein designated p48 is somewhat unclear. However, a hydrophobic region (residues 360-379) in the p48 has been shown to interact

with the vesicle-associated membrane protein-associated protein A (VAP-A), which plays a role in SNARE-mediated vesicle fusion, likely regulating vesicle docking and fusion (Ettayebi and Hardy, 2003). As replication of positive-strand RNA viruses occurs anchored to the cytoplasmic face of the cellular membrane, p48 is also suspected to target NoV replication complexes to specific membranes, functioning as a scaffolding protein for replication complex assembly (Ettayebi and Hardy, 2003; Hardy, 2005). Finally, p48 has been found to interact with the Golgi apparatus in transfected cells and cause disassembly of the Golgi complex, suggesting that p48 may play a role in the induction of intracellular membrane rearrangement associated with positive-strand RNA virus replication (Fernandez-Vega et al., 2004).

The p22 protein has also been suggested to contribute to viral complex formation on intracellular membranes as it has been found to associate with the Golgi apparatus and endosomes and cause alterations in the Golgi morphology (Hyde and Mackenzie, 2010). Furthermore, p22 has been found to antagonize COPII vesicle trafficking resulting in inhibition of cellular protein secretion (Sharp et al., 2010).

The NTPase belongs to the superfamily 3 of RNA helicases. The NTPase has been speculated to be involved in RNA replication and encapsidation by creating a dynamic structural scaffold that responds to the changing requirement during virus replication (Pfister and Wimmer, 2001).

Finally, the POL protein encoded in the c-terminal of ORF1 is an RNA-dependent RNA polymerase essential for the replication of the NoV genome. In addition to the fully processed form of POL the existence of a PRO-POL precursor has been demonstrated. This precursor is a bifunctional enzyme with both proteinase and polymerase activity during replication (Belliot et al., 2005).

2.5 The NoV capsid protein

The NoV virion is assembled by 180 molecules of the major structural protein VP1 organised into 90 dimers and exhibits a T = 3 icosahedral symmetry with defined surface structure, in which cup like depressions or hollows are evident at three- and fivefold axes of symmetry (Figure 3) (Prasad et al., 1994).

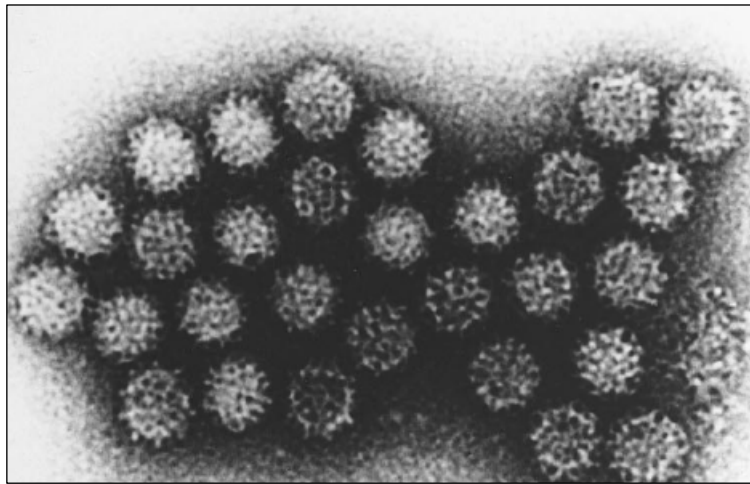

Figure 3. [Negative-contrast electron microscopy of NoV](#) in human stool (Green et al., 2000)

The major capsid protein VP1 has a molecular weight of ~57 kDA and folds into two principal domains designated S for shell domain and P for protruding domain, which are linked together by a flexible hinge region of 10 residues (Jiang et al., 1993; Prasad et al., 1999). The S domain is involved in formation of the core of the icosahedral shell, while the P domain forms arches extending from the shell and stabilise the capsid by a dimeric interaction (Figure 4) (Bertolotti-Ciarlet et al., 2002; Prasad et al., 1999). Based on x-ray chystallographic of a NoV GI.I strain it has be shown that NH₂-terminal 225 residues constitute the S domain. Within the S domain residues 50 to 225 fold into a classical eight-stranded anti-parallel β -sandwich, a common motif seen in many viral capsid proteins. The P domain is formed by residues 225 to the COOH-terminus and is unlike that of any other viral protein. The domain is made of two subdomains: P1, consisting of residues 226 to 278 and 406 to 520; and P2, consisting of residues 279 to 405. The P1 subdomain consists largely of anti-parallel β -strands and a α –helix, whereas the P2 subdomain folds into a compact structure consisting of six β -strands similar to that of the RNA binding domain 2 in the eukaryotic translation elongation factor-Tu (EF-Tu), suggesting a role of P2 in viral or cellular RNA translation and regulation of protein synthesis. The P2 subdomain is located on the exterior of the capsid and residues 280 to 400 in P2 are highly variable among NoV strains. Hence, it is suspected that this hypervariable region contains the determinants of strain specificity and is involved in receptor binding (Prasad et al., 1999).

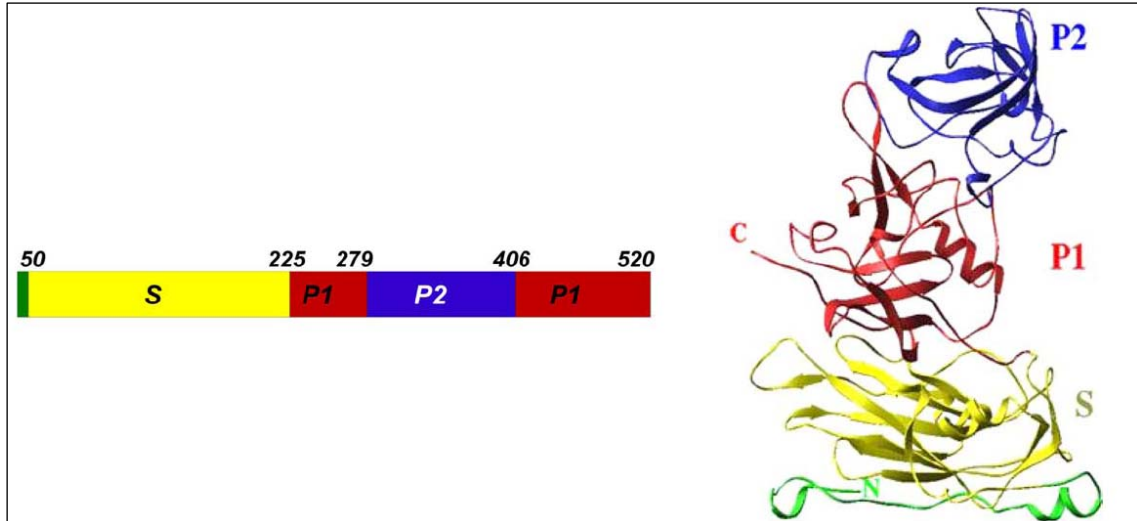

Figure 4. VP1 domains and ribbon representation of a VP1 monomer. The bar illustrates domains of VP1 and the colours correspond to the ribbon structure. The small NH₂-terminal domain (green) faces the interior of the particle, while the hypervariable P2 domain (blue) faces the exterior (Hardy, 2005).

In addition to VP1, 1-2 copies of minor structural protein VP2 is incorporated into the capsid (Glass et al., 2000). The VP2 protein has a predicted isoelectric point of >10 and it has therefore been suggested that VP2 may be involved in RNA genome packaging through binding of the RNA (Glass et al., 2000; Hardy, 2005). Furthermore VP2 has been shown to stabilize the viral capsid (Bertolotti-Ciarlet et al., 2003).

The NoV particle is negatively charged at environmentally relevant pH as theoretical and empirical isoelectric point (pI) values of NoV capsid protein VP1 from several strains have been found to be in the range of 5.2-5.7 and 5.5-6.9 for NoV GI and GII, respectively (Goodridge et al., 2004).

Chapter 3

Epidemiology, clinical aspects and immunity

3 Epidemiology, clinical aspects and immunity

3.1 Transmission of norovirus

NoVs are transmitted directly via the faecal-oral route directly by person-to-person contact or indirectly via contaminated food, water or fomites (D'Souza et al., 2006; Koopmans and Duizer, 2004). In addition, dissemination of NoV through aerosol droplets, especially following vomiting, has been suggested (Cheesbrough et al., 2000; Marks et al., 2000; Marks et al., 2003). Clinical observations as well as detection of NoV RNA on horizontal surfaces 1.5 meters above normal reach (>1.5 m) in a hotel during a NoV outbreak have indicated that aerosolized NoV particles may travel distances beyond 1.5 meters (Cheesbrough et al., 2000).

The infectious dose of NoV is low with an estimated infectious dose 50% (ID₅₀) for the Norwalk virus (strain GI.1) of 18 viral particles (Teunis et al., 2008) and virus particles are shed in high quantities in stool and vomitus of infected persons. During the initial stage of infection up to 10¹¹ genomic NoV copies per gram stool has been reported (Atmar et al., 2008). Shedding of virus may continue after clinical recovery and may last three to four weeks in otherwise healthy people. The shedding period can be even longer for young children (Atmar et al., 2008; EFSA Panel on Biological Hazards (BIOHAZ), 2011). The high degree of shedding in combination with the low infective dose of NoV readily results in a high degree of secondary spread, allowing amplification of an outbreak, particularly in closed settings such as healthcare institutions and cruising ships (Atmar, 2010; Huffman et al., 2003).

NoV contaminated drinking water has been the source of numerous outbreak in the industrialised countries (Borchardt et al., 2011; Carrique-Mas et al., 2003; Maunula et al., 2009a; Maunula et al., 2005; Nygard et al., 2004; Nygard et al., 2003; Räsänen et al., 2010; Riera-Montes et al., 2011; ter Waarbeek et al., 2010). Broken sewage pipes and septic systems may lead to NoV contamination of the drinking water supply (Borchardt et al., 2011; Nygard et al., 2003). In addition, contamination with NoV may arise after heavy rainfall due to discharge of sewage into surface water (Lodder et al., 2010).

Transmission of NoV by contaminated food is a recognised problem. In Denmark, e.g., NoV was found to be the most frequent cause of foodborne outbreaks in 2010 with a total of 1266 registered cases accounting for 61% of all foodborne outbreaks (Anon, 2011a). In particular, consumption of raw or lightly cooked food such as shellfish (Baker et al., 2011; David et al., 2007; Prato et al., 2004; Westrell et al., 2010) and fresh produce such as raspberries (Falkenhorst et al.,

2005; Le Guyader et al., 2004a; Maunula et al., 2009b) and lettuce (Ethelberg et al., 2010; Gallimore et al., 2005; Makary et al., 2009; Wadl et al., 2010) has been associated with NoV outbreaks. Contamination can often be linked to infected food-handlers, but may occur at almost any step in the food chain (Koopmans and Duizer, 2004). Contamination of shellfish may for instance occur through human faecal pollution of the growing areas and fresh produce can be contaminated as a result of pre-harvest and post-harvest practices. Pre-harvest contamination of fresh produce can occur through use of faecal-polluted irrigation water and improperly treated manure and biosolids containing human faecal material for fertilization (Wei and Kniel, 2010). Post-harvest practices representing a risk include the use of polluted water for washing or ice made from polluted water for cooling (Anon, 2002).

NoVs cause infection in person of all ages throughout the year, but exhibit strong wintertime seasonality in temperate climates (Lopman et al., 2009; Mounts et al., 2000). NoV infections are therefore often referred to as “winter vomiting disease”. Certain genotypes are more likely to be associated with specific routes of transmission. For example, GII.4 strains are more commonly associated with person-to-person transmission, while GI strains are identified more frequently in shellfish associated outbreaks (Atmar, 2010).

3.2 Clinical illness

The characteristic symptoms of NoV infections include vomiting, mild to moderate non-bloody diarrhoea, nausea and abdominal discomfort. Other symptoms may be headache, fever, malaise, chills and myalgia (Huffman et al., 2003; Wyatt et al., 1974). The incubation period of NoV is approximately 48 hours, with illness typically lasting 24-48 hours after onset (Wyatt et al., 1974). Asymptomatic infections are common and may contribute to the spread of the infection (Vasickova et al., 2005). Replication is believed to take place in the small intestine. Abnormal intestinal histology with shortening and broadening of the intestinal villi, crypt hypertrophy, and increased mitosis in the crypts have been reported in proximal small intestine of human volunteers 12-48 hours after inoculation with NoV. These abnormalities were found to persist for at least 4 days after clearance of clinical symptoms (Schreiber et al., 1973). Inflammation of the mucosa of the small bowel reduces the adsorptive capacity of the villi contributing to diarrhoea. The crypt hypertrophy and epithelial cell proliferation may represent the body’s response for replacing virus-damaged adsorptive cells (Kingsley and Richards, 2003). In developed countries NoV infections are

generally self-limiting and rarely require hospitalisation. However, severe cases of dehydration and deaths resulting from NoV infections have been reported among elderly or immune compromised persons (Huffman et al., 2003).

3.3 Host susceptibility

Infection by NoV has been found to rely on recognition of human histoblood group antigens (HBGAs) as ligands or receptors for attachment, an early infection event that most likely controls host susceptibility and resistance to NoVs (Tan and Jiang, 2011). HBGAs are a family of complex glycans that are found on the surfaces of red blood cells and on the mucosal epithelia of the respiratory, genitourinary and digestive tracts. They are also present in biological secretions of humans, including saliva (Donaldson et al., 2008; Tan and Jiang, 2005). HBGA expression is regulated by several genes that determine which of three biosynthetic pathways is followed, and this variation leads to polymorphic ABO, Lewis and secretor phenotypes (Figure 5).

Correlations between binding patterns of NoV to HBGAs and susceptibility to infection and illness have been reported in several studies. Particularly the FUT2 enzyme, encoded by the FUT2 gene carried by secretor-positive individuals, has been reported to have important role in the susceptibility to NoV infection. Individuals who do not possess a functional FUT2 enzyme (secretor-negative) have been found to be resistant to infection with GI.1 (Hutson et al., 2005; Lindesmith et al., 2003), GII.3 (Tan et al., 2008) and most GII.4 NoVs (Atmar, 2010; Kindberg et al., 2007; Tan et al., 2008). Secretor-negative individuals constitute about 20% of the white population and are characterized by the absence of HBGAs in the saliva and mucosal tissues (Rydell et al., 2011). Other studies have, however, shown that secretor-negative individuals can be infected with GII.2 (Snow mountain strain) (Lindesmith et al., 2005), GI.3 (Jönköping strain) (Nordgren et al., 2010) and GII.4 (Valencia strain) (Carlsson et al., 2009). This indicates that binding patterns of NoVs to HBGAs may vary between genotypes, and even within a genotype (Atmar, 2010). In addition to the secretor status, the ABO blood group antigens and the Lewis phenotype may also play a role in the susceptibility to NoV infection. An increased susceptibility to GI.1 (Norwalk strain) has for instance been associated with blood group O whereas individuals belonging to group B have been found to have a lower incidence of infection due to weak ligand binding of NoV GI.1 to the type B carbohydrate antigens (Hutson et al., 2002; Lindesmith et al., 2003). Although, individual NoV strains may infect only a subset of the human population, diverse

HBGA-binding affinities in NoVs may collectively allow nearly all individuals to be susceptible to one or more strains (Donaldson et al., 2010).

Acquired immunity is the other mechanism by which resistance to NoV infection occurs (Atmar, 2010). Wyatt et al. (1974) demonstrated that volunteers challenged with the same NoV strain 6-14 weeks after symptomatic infection did not develop illness. However, cross-challenge with antigenic unrelated NoV strains demonstrated the acquired immunity may be strain specific (Wyatt et al., 1974). Furthermore, acquired immunity may not be long lasting as Parrino et al. (1977) found volunteers to be susceptible to reinfection when challenged with the same virus strain 27 to 42 months after symptomatic infection.

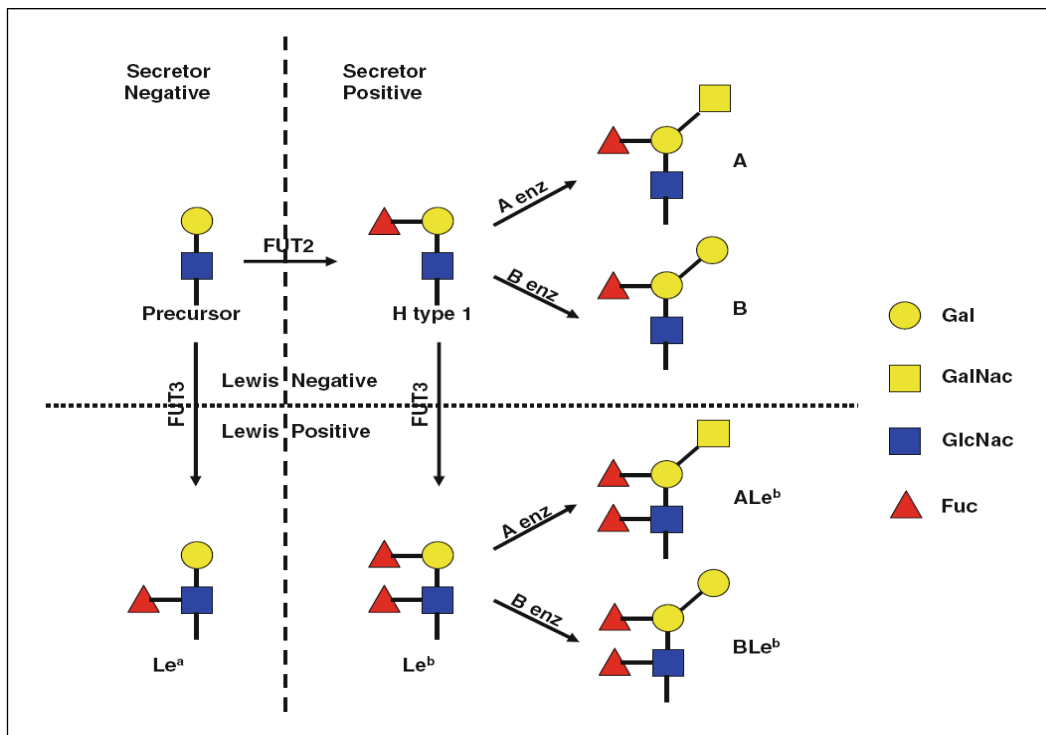

Figure 5. Histoblood group synthetic pathway for blood group ABO and Lewis antigens shown based on a type 1 precursor. The type 1 precursor glycan (Gal β 1-3GlcNAc) can be modified by FUT2, an α (1,2) fucosyltransferase, which adds a fucose residue to the type 1 precursor to produce the H type 1 glycan (H-antigen). H type 1 can be further modified in the presence of FUT3, an α (1,3) or α (1,4)fucosyltransferase, to produce Lewis-b (Le^b) and by enzymes A (N-acetyl-galactosamine-transferase) and B (galactosyltransferase) to produce the A and B histoblood group antigens (HBGAs). If FUT2 is non-functional, then a person is a non-secretor, although the H type 1 precursor can still be modified to produce Le^a in the presence of a functional FUT3. Persons with a functional FUT2 enzyme are called secretor positive because the ABO HBGAs are found in the secretions and on the mucosal surfaces. In the type 2 and 3 pathways actions similar to that seen for type 1 will take place. (Atmar, 2010).

Chapter 4

Virus recovery strategies

4 Virus recovery strategies

4.1 Sample preparation

Successful virus detection in food, water and environmental samples is strongly dependent on sample treatment. Viruses need only to be present in very low numbers to constitute a risk, and they will not multiply in food, water and environment. Efficient and robust concentration and extraction procedures that can deliver viruses from sample to detection assay are therefore crucial (Rzezutka et al., 2005).

4.1.1 Virus concentration from water

Enteric viruses, in particular NoV, play an important role in waterborne disease. Hence, it is essential to have efficient recovery methods available for both screening and outbreak investigations. For recovery of viruses from water an optimal method must fulfil the following criteria: (i) be rapid and easy to perform; (ii) have a high recovery efficiency; (iii) be applicable for concentration of a range of viruses; (iv) provide a small volume of concentrate; (v) not be costly; (vi) be capable of processing large volumes of water; (vii) be repeatable (within laboratory) and be reproducible (between laboratories) (Block and Schwartzbrod, 1989). Although numerous methods have been developed for recovery of enteric viruses from water no single method fulfils all these requirements (Wyn-Jones and Sellwood, 2001).

Virological analysis of water is usually a two-stage process. As the levels of viruses in natural waters are often low the sample must be processed to concentrate the viruses before specific virus detection can be performed (Karim et al., 2009; Wyn-Jones and Sellwood, 2001). A variety of strategies has been used for concentration of viruses from water samples. These include virus adsorption-elution (VIRADEL) techniques, ultrafiltration, precipitation, ultracentrifugation, lyophilisation, two-phase separation with polymers, immunoaffinity, and monolithic chromatographic columns (Bosch et al., 2008; Bosch et al., 2011; Wyn-Jones and Sellwood, 2001). In the following sections the basics of the most important of these concentration techniques will be described.

4.1.1.1 Virus adsorption-elution

The VIRADEL techniques have been the most commonly used methods for recovery of enteric viruses from water for decades (Ikner et al., 2011). These methods include a primary step to concentrate viruses from larger volumes of water using an adsorption matrix, followed by virus elution from the matrix (Ikner et al., 2011). The viruses can be adsorbed onto a number of different matrices by electrostatic and hydrophobic interactions (Karim et al., 2009). Matrices, which have been used for adsorption, included negatively and positively charged membranes or cartridge filters, gauze pads, and glass powder or glass wool. Negatively and positively charged filters are most widely used (Karim et al., 2009).

Positively charged filters can be used directly for adsorption of the viruses owing to the predominantly negative charge present on the surface of viruses in natural waters (Lee et al., 2011; Wyn-Jones and Sellwood, 2001). Despite filters being costly, methods based on positively charged filters are therefore currently among the best possibilities for virus recovery (Bosch et al. 2008). Indeed, the current draft method suggested by the European standardisation group (CEN/TC 275/WG6/TAG4) as a future standard for recovery of NoV and hepatitis A virus in bottled water is a modified version of the method described by Gilgen et al. (1997), which utilises positively charged filters for virus adsorption.

The use of negatively charged filters requires pre-conditioning of the water samples (Lee et al., 2011). Pre-conditioning generally consists of acidification to pH 3.5 or by addition of multivalent cations such as $MgCl_2$ or $AlCl_3$ to adjust the ionic strength of the sample (Karim et al., 2009; Victoria et al., 2009; Wyn-Jones and Sellwood, 2001). Because of this need for conditioning the water the use of negatively charged filters can be difficult for field sampling (Karim et al., 2009).

Gauze pads have been used for adsorption of enteric viruses for field sampling in the past (Fattal and Katzenelson, 1976; Manor et al., 1999; Sekla et al., 1980). However, the recovery efficiency of viruses using this technique has in some cases been reported to be low and recovery of viruses from larger volumes of water has been found to be poor (Fattal and Katzenelson, 1976). Hence, the use of gauze pads seems to be inferior to other more refined methods currently available.

Finally, glass wool or glass powder is an alternative adsorptive material for virus concentration. Glass wool contains both hydrophobic and electropositive sites on the surfaces capable of adsorbing viruses at near-neutral pH and like positively charged filters glass wool requires no conditioning of the water with the exception of pH adjustment under some

circumstances (Lambertini et al., 2008). The advantage of using glass wool for recovery of enteric viruses is that it is cost-effective (Bosch et al., 2011). Glass wool has previously been successfully applied for screening for rotaviruses, adenoviruses, astroviruses and hepatitis A viruses in South Africa (Taylor et al., 2001; van Heerden et al., 2004; van Zyl et al., 2004; van Zyl et al., 2006; Venter et al., 2007). Nevertheless, variability in recovery has been reported using glass wool (Lambertini et al., 2008). Moreover, packaging of the glass wool into columns requires experience.

After adsorption, virus must be eluted from the matrix into a smaller volume. The most commonly used elution solutions have a pH of 9.0-9.5 and consists of 1% to 3.0% beef extract with glycine to provide buffer capacity (Albinana-Gimenez et al., 2009; Gilgen et al., 1997; Karim et al., 2009; Lambertini et al., 2008). Nevertheless, if co-extracted beef extract may confer inhibition of molecular detection assays (Ikner et al., 2011). Alternative elution solutions include sodium hydroxide (Albinana-Gimenez et al., 2009; Haramoto et al., 2004; Haramoto et al., 2005; Haramoto et al., 2009; Katayama et al., 2002; Victoria et al., 2009), urea-arginine phosphate buffer (Jothikumar et al., 1991) and sodium polyphosphate buffer with glycine (Ikner et al., 2011). To increase the virus concentration in the sample, secondary concentration of the eluent is often necessary. Methods for secondary concentration include ultrafiltration, precipitation and ultracentrifugation.

4.1.1.2 Ultrafiltration

Ultrafiltration is an attractive alternative approach for concentration of viruses from water that requires no preconditioning of the sample. Ultrafiltration separates viruses from the water by permitting passage of water and low molecular mass solutes through the membrane of the ultrafilter while retaining viruses and other macromolecules. Most ultrafilters employ tangential flow, where the sample is repeatedly swept past the membrane until the virus containing retentate is reduced sufficiently in volume to allow further processing (Figure 6) (Wyn-Jones and Sellwood, 2001).

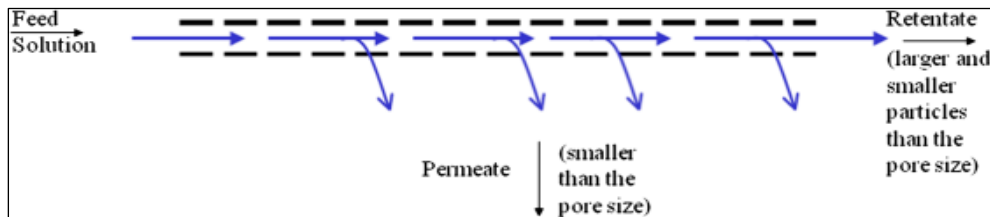

Figure 6. Principle of ultrafiltration using tangential flow. Sample is flowing parallel to the membrane surface, which is permeable to particles smaller than the pore size (e.g. water and salts), while particles larger than the pore size (e.g. viruses) are excluded from crossing the membrane (Pavanasam et al., 2011).

Several parameters influence the efficiency of the ultrafiltration including membrane modules and materials used, operation conditions, virus type as well as water source and quality (Pavanasam et al., 2011). Turbid surface waters samples, for instances, may take a long time to process and tend to clog the membranes (Wyn-Jones and Sellwood, 2001).

A variety of membrane modules and materials has been used for virus concentration and includes cellulose membrane based centrifugal filter devices and hollow fiber ultrafilters. Centrifugal filter devices are often not applicable on larger volumes of water but have been widely used as a secondary concentration method for NoV (Di Pasquale et al., 2010; Gilgen et al., 1997; Haramoto et al., 2004; Haramoto et al., 2005; Haramoto et al., 2009; Katayama et al., 2002; Victoria et al., 2009). Hollow fiber ultrafilters have, however, been successfully used for primary concentration of viruses, such as NoV, MNV, poliovirus (PV), and MS2, from large volumes (50-100 L) of drinking water (Gibson and Schwab, 2011a; Hill et al., 2007; Hill et al., 2009; Hill et al., 2010; Rhodes et al., 2011). The disadvantage of ultrafiltration using hollow fibers is the high initial cost of the equipment (Wyn-Jones and Sellwood, 2001).

4.1.1.3 Precipitation

Precipitation can be used for primary concentration of viruses from water but as precipitation is only applicable to smaller volumes of water it is mainly used for secondary concentration. Precipitation based re-concentration of virus can occur by the means of inorganic (Farrah et al., 1976; Shields and Farrah, 1986) or organic flocculation (Albinana-Gimenez et al., 2009; Hurst et al., 1984; Katzenelson et al., 1976) or polyethylene glycol (PEG) based precipitation. Organic flocculation and PEG precipitation are the most commonly used principles.

Organic flocculation relies upon association of viruses with a *de novo* precipitate that forms spontaneously upon lowering the pH of a protein solution (e.g. beef extract) to pH 3.5 (Hurst

et al., 1984; Katzenelson et al., 1976). The precipitate and associated viruses can subsequently be collected by low-speed centrifugation, and viruses are recovered by dissolving the precipitate in a small amount of moderately alkaline buffer (Hurst et al., 1984).

PEG is a chemically inert, nontoxic, water-soluble, synthetic polymer known to precipitate a number of proteins and viruses. PEG acts as an inert solvent sponge, reducing solvent availability. With increasing concentration of PEG the effective protein concentration is increased until solubility is exceeded and precipitation occurs (Atha and Ingham, 1981; Fahie-Wilson and Halsall, 2008). One disadvantage of using these methods is the possibility of co-precipitation of substance that can inhibit subsequent detection assays.

4.1.1.4 Ultracentrifugation

Viruses can be concentrated from a sample by physical sedimentation or isopycnic separation using ultracentrifugation, provided sufficient g-force and time is used (Bosch et al., 2008; Wyn-Jones and Sellwood, 2001). Although ultracentrifugation have been used as a primary concentration method for recovery of enteric viruses, including NoV, from sewage (Bofill-Mas et al., 2006; Fumian et al., 2010; Pina et al., 1998; Rodriguez-Diaz et al., 2009), limited volumes can be processed and the method is therefore not applicable for primary concentration of virus from larger amounts of natural water. However, it does find a use as a secondary concentration method (Wyn-Jones and Sellwood, 2001). A disadvantage of the method is that the initial cost of an ultracentrifuge is high, but after that the cost per sample is low (Fumian et al., 2010).

4.1.1.5 Recovery efficiency of concentration methods

The various concentration methods each have their own advantages and disadvantages. The applicability and efficiency of the methods depend on factors such as water source, quality and sample volume. The physicochemical quality of the water such as pH, conductivity, turbidity, presence of particulate matter and organic acids can all affect the recovery efficiency (Bosch et al., 2011). Unfortunately, only limited information exists regarding the efficiency of the methods to recover NoV. Table 1 contains a summary of the concentration methods for which the efficiencies to recover NoV or NoV surrogates have been calculated.

Table 1. Recovery efficiencies of methods used for concentration of norovirus or norovirus surrogates from various water types.

Method	Water types/volumes	Recovery efficiency (Mean±Standard deviation)	References
Adsorption-elution methods			
<i>Negatively charged filters</i>			
Preconditioning (MgCl ₂); filtering (Millipore; HA 0.45 µl filter); rinse (H ₂ SO ₄ , pH3.0), elution (NaOH, pH 10.8); neutralisation (TE buffer + H ₂ SO ₄); ultrafiltration (Centrprep YM-50)	Tap water (0.5 L-2L) ^{1,2} River water (0.25 L-2L) ^{1,2} Bottled water (0.5-2L) ^{1,2} Sea water (2L) ³	Tap water: 80±3% NoV ^a (0.5L) ¹ ; 3±1% NoV (2L) ³ River water: 15±5% NoV (0.25L) ¹ ; 18±9% NoV (2L) ³ Bottled water: 167±40% NoV (0.5L) ¹ ; 23±17% NoV (2L) ³ Sea water: 5±7% NoV (2L) ³	¹ Haramoto et al. 2009 ² Victoria et al. 2009
Filtration (AlCl ₃ coated Millipore; HA 0.45 µl filter); rinse (H ₂ SO ₄ , pH3.0); elution (NaOH, pH 10.8); neutralisation (TE buffer + H ₂ SO ₄); ultrafiltration (Centrprep YM-50)	Tap water (0.5L) River water (0.25L) Bottled water (0.5L)	Tap water: 50±19% NoV (0.5L) River water: 35±15 NoV (0.25L) Bottled water: 60±50% NoV (0.5L)	Haramoto et al. 2009
<i>Positively charged filters</i>			
Pre-filtration; filtration (Zetapore; 0.45 µl membrane); elution (Glycine buffer + 1% beef extract, pH 9.5); ultrafiltration (Centricon-100)	Tap water (1L) River water (1L)	Tap water: 1% NoV GIH (1L)	Gilgen et al. 1997
Filtration (Zetapore; MK electropositive 0.45 µl filter); elution (Glycine buffer + 1% beef extract, pH 9.5); flocculation (3% beef extract, pH 3.5); centrifugation	Tap water (50L)	Tap water: <1% NoV GIH (50L)	Albana-Gimenez et al. 2009
Filtration (Zeta Plus Virosep IMDS; glass-cellulose filter); elution (Glycine buffer + 1.5% beef extract, pH 9.0); re-concentration by celite adsorption/elution	Tap water (10-100L) River water (10-100L)	Tap water: 1±1% NoV GIH (10-100L) River water: 0.4±2% NoV GIH (10-100L)	Karim et al. 2009
Filtration (NanoCerami; nano alumina filter); elution (Glycine buffer + 1.5% beef extract, pH 9.0); re-concentration by celite elution	Tap water (10-100L) River water (10-100L)	Tap water: 4±1% NoV GIH (10-100L) River water: 12±16% NoV GIH (10-100L)	Karim et al. 2009
Filtration (Sartorius; 0.45µm polyanamide filter); direct RNA elution (Lysis buffer)	Tap water (1.5L) ¹ Bottled water (1.5L) ²	Tap water: 43±29% NoV GIH (1.5L) ¹ ; 46±24% NoV GIH (1.5L) ¹ Bottled water: 61±0% NoV GIH (1.5L) ² ; 35±25% NoV GIH (1.5L) ²	¹ Manuscript V (This thesis) ² Schultz et al. 2011
Filtration (Sartorius; 0.45µm electropositive polyanamide filter); Elution (Glycine buffer + 1% beef extract, pH 9.4); ultracentrifugation (165,000×g, 4h)	Bottled water (1.5L)	Bottled water: 0.5±0.4% FCV ^a (1.5L) ^{1,2}	¹ Di Pasquale et al. 2010 ² Schultz et al. 2011
<i>Glass wool</i>			
Filtration (Glass wool); elution (Glycine buffer + 3% beef extract, pH 9.5); flocculation (PEG 8000 + NaCl); centrifugation	Tap water (10-1500L) Ground water (10-1597L)	Tap water: 30±27% NoV GIH (20L) Ground water: 39±1% NoV GIH (20L) ¹ ; 24±12% NoV GIH (10-20L)	Lambertini et al. 2008
Pre-acidification (pH 3.5); filtration (Glass wool); elution (Glycine buffer + 3% beef extract, pH 9.5); flocculation (pH 3.5); centrifugation	Tap water (10L)	Tap water: 3% NoV GIH [range 0-19%] (10L)	Albana-Gimenez et al. 2009
Ultrafiltration			
Ultrafiltration (Infilco Degremont cartridge); elution (NaOH); neutralisation; filtration (40-Kd pore filter)	Tap water (10L)	Tap water: <1% NoV GIH (10L)	Albana-Gimenez et al. 2009
Hollow fiber ultrafiltration (Baxter; cellulose triacetate dialyse filter blocked with 0.1% NaPP); Re-concentration (Centricon Plus-70)	Tap water (100L)	Tap water: 41±34% MINV ^b (100L)	Gibson & Schwab 2011
Monolithic chromatographic columns			
Filtration (CIM, positively charged QA monolithic column); elution (Phosphate buffer + NaCl)	Bottled water (1.5L)	Bottled water: 6±6% FCV (1.5L) ^{1,2}	¹ Kovacic et al. 2009 ² Schultz et al. 2011

^aNoV: norovirus; ^bMINV: murine norovirus; ^cFCV: feline calicivirus

4.1.2 Virus concentration from food

Virus analysis of food matrices is complex and many methods have been described. The choice of method for virus release and concentration is depending on the food matrix and the route of contamination involved. Viruses must to be eluted from the surface of the food item or extracted from homogenized tissues in case of intrinsic contamination (e.g. oyster and mussels) (Bosch et al., 2011).

4.1.2.1 Bivalve molluscan shellfish

Bivalve molluscan shellfish are filter-feeders and can filter large volumes of water as part of their feeding activities. In the process they are able to accumulate viruses (e.g. NoV and HAV) present in the environment due to human-faecal pollution (Le Guyader et al., 2009). As shellfish such as oyster are often consumed raw this may lead to a significant health risk (de Roda Husman et al., 2007). Thus, to protect the consumer it is important to have sensitive and rapid methods available for recovery and detection of viruses present in the shellfish.

Numerous different procedures, commonly involving many different sequential steps, have been described for recovery of virus from shellfish (de Roda Husman et al., 2007). The initial steps consist of virus elution from the shellfish tissues, purification and virus concentration. The approaches can be further subdivided based on whether the whole shellfish or dissected tissues are analysed (Le Guyader and Atmar, 2007).

For analysis of whole shellfish, sample sizes of 10-50 g shellfish have generally been used (Le Guyader and Atmar, 2007). In these methods whole shellfish are homogenised and viruses are eluted from the tissue using a large volume of buffer usually containing glycine and with a pH of 9.0-10.0 (Chironna et al., 2002; Croci et al., 2000; Kingsley and Richards, 2001; Muniain-Mujika et al., 2000). Alternatively, acid adsorption of the viruses to the homogenised tissue solids by reducing the conductivity by adding water and adjusting the pH to 4.8-5.0 has been performed prior to the virus elution with a glycine-NaCl buffer with pH 7.5 (Mullendore et al., 2001; Shieh et al., 1999; Sobsey et al., 1978; Suñén and Sobsey, 1999). After virus elution, samples have typically been purified via chloroform or Freon extraction and viruses have been concentrated by PEG precipitation (Chironna et al., 2002; Croci et al., 2000; Kingsley and Richards, 2001; Mullendore et al., 2001; Shieh et al., 1999) or ultracentrifugation (Muniain-Mujika et al., 2000). Analysis of whole

shellfish is a particular useful approach for small species, such as clams or cockles, where dissection is technically difficult (Le Guyader and Atmar, 2007).

Most methods currently in use, however, focus on the dissected bivalve digestive diverticulum (digestive tissue) as a starting material for virus recovery since the majority of accumulated viruses have been shown to be located here (Lees and CEN, 2010). Testing the digestive tissue for virus has several advantages in comparison with testing whole shellfish. Targeting only the digestive tissue reduced processing time, decreases the amount of inhibitory substances present in the sample, and increased sensitivity (Atmar et al., 1995; Bosch et al., 2011; Le Guyader and Atmar, 2007). A number of protocols for the release, concentration and purification of viruses from digestive tissue have been described. Most of these are based on analysis of 1.5-2 g chopped or homogenised digestive tissue (Le Guyader and Atmar, 2007). Viruses have been eluted from the digestive tissue using glycine based buffers (Baert et al., 2007; Comelli et al., 2008; Myrmel et al., 2004) or chloroform-butanol (Atmar et al., 1995; Nishida et al., 2003) before virus being concentrated by PEG precipitation (Atmar et al., 1995; Beuret et al., 2003) or ultracentrifugation (Myrmel et al., 2004; Nishida et al., 2003). However, for virus recovery from digestive tissue, direct lysis of the virus particles is a more simple approach that is frequently used (Bosch et al., 2011; Le Guyader and Atmar, 2007). For direct lysis, proteinase K (Comelli et al., 2008; Gentry et al., 2009; Greening and Hewitt, 2008; Jothikumar et al., 2005; Uhrbrand et al., 2010), Trizol (Boxman et al., 2006), α -amylase (Iizuka et al., 2010) or Ziconia beads together with a denaturing buffer (de Roda Husman et al., 2007) have been employed.

4.1.2.2 Fresh produce

Viruses are believed mainly to be present on the surface of fresh produce. Thus, most methods for recovery for viruses from these matrices are washing procedures focusing on eluting viruses from the surfaces of the fresh produce. For elution mainly alkaline buffers such as glycine (Le Guyader et al., 2004a), glycine-buffered saline (Le Guyader et al., 2004b), Tris-glycine with 1-3% beef extract (Butot et al., 2007; Dubois et al., 2002; Dubois et al., 2007; Stals et al., 2011) as well as sodium bicarbonate with 1% beef extract or 1% soya protein (Rzezutka et al., 2005; Rzezutka et al., 2006) have been used. After elution, food debris is generally removed from the virus containing supernatant by low speed centrifugation. To facilitate this separation some protocols additionally include a flocculation step using Cat-Floc (Le Guyader et al., 2004a; Le Guyader et al., 2004b; Rzezutka et al., 2005; Rzezutka et al., 2006). In soft fruit samples addition of pectinase either before

or after removal of the debris has been used to eliminate residual pectin which can form a gelatinous substance (Butot et al., 2007; Dubois et al., 2002; Dubois et al., 2007; Rzezutka et al., 2005; Rzezutka et al., 2006; Stals et al., 2011). A variety of protocols for concentration of the viruses eluted from fresh produce has been reported and includes PEG precipitation (Dubois et al., 2002; Dubois et al., 2007; Le Guyader et al., 2004a; Le Guyader et al., 2004b; Morales-Rayas et al., 2010; Stals et al., 2011), ultracentrifugation (Rzezutka et al., 2005; Rzezutka et al., 2006), ultrafiltration (Butot et al., 2007), and anion or cation exchange filtration (Morales-Rayas et al., 2010). Finally, the virus concentrate is in some cases subjected to chloroform-butanol extraction to remove inhibitory substance before nucleic acid extraction (Dubois et al., 2002; Stals et al., 2011).

4.1.3 Sampling of viral aerosols

Although there is a concern that airborne-transmission of enteric viruses may occur, the importance of such airborne spread is not well defined and only few studies relating to the detection of airborne enteric viruses exist (Table 2). A crucial issue for detecting airborne viruses is the collection of the virus from the air. Collection of viral aerosols is normally conducted by creating a vacuum through a sampling apparatus. This will result in the air entering the device where bioaerosols present in the air will be retained by physical separation (Gilbert and Duchaine, 2009). Different principles such as impaction, impingement, filtration and electrostatic precipitation have been used for viral aerosol sampling.

Impact samplers use the inertial forces of particles to separate them from the airflow entering the sampler. Air enters the sampler via an inlet nozzle. Particles with enough inertia are deposited onto a solid surface such as an agar medium for culture based analysis or an adhesive-coated surface (Gilbert and Duchaine, 2009). Examples of solid impactors are Andersen samplers, which have multiple stages and can separate particles with different size, slit samplers and cyclone samplers (Verreault et al., 2008). Although solid impactors are usually more efficient at capturing large particles (Verreault et al., 2008), they have previously been used successfully for sampling and culture-based detection of airborne enterovirus and reovirus at WWTPs (Carducci et al., 1995; Carducci et al., 2000). Disadvantages using impaction as a sample method is that dehydration or impact trauma can affect the virus infectivity (Bosch et al., 2011).

Impingers are samplers containing a liquid collection medium. Like solid impactors, aerosol collection using impingers relies on the inertial force of particles (Gilbert and Duchaine, 2009). Air enters the sampler horizontally through a glass tube, which curves to a vertical position,

forcing the air to change direction and flow downward where the largest particles are impacted onto the liquid. Very small particles may be collected by diffusion with small bubbles formed in the liquid of the impinger but reaerosolisation of the particles due to scavenging properties of air bubbles may be a problem. Advantages of impingers are that the liquid collection medium prevents desiccation and facilitates the extraction of genetic material for subsequent analysis (Verreault et al., 2008). Several types of impingers are available and include All-glas impingers (AGI) and BioSamplers. The latter have been used in a study to qualitatively detect NoV genomes present in air downwind from a biosolid land application site by conventional RT-PCR after concentrating the collection medium via ultrafiltration (Brooks et al., 2005). Nevertheless, impingers have been reported to be inefficient for sampling of sub-micrometer and ultrafine virus particles, with collection efficiencies below 10% for viruses in the size range of 30-100 nm (Hogan et al., 2005).

Filter samplers are frequently used for sampling of airborne viruses because they retain particles with an aerodynamic size below 500 nm more efficiently than other samplers (Verreault et al., 2008). Using filter samplers airborne particles are collected by passing air through a porous medium, generally a membrane, to which particles can be retained due to inception, inertial impaction, diffusion, and electrostatic attraction (Gilbert and Duchaine, 2009). Several types of filter materials with various pore sizes are available and include cellulose, polytetrafluoroethylene, polypropylene, polycarbonate and gelatine filters (Verreault et al., 2008). Of these polypropylene filters (Wallis et al., 1985) and polycarbonate filters (Tseng et al., 2010; Uhrbrand et al., 2011) have been used for sampling of enteric viruses. Although, sampling with filters are compatible with molecularly based detection methods that do not require infectious virus particles, the approach is less efficient for recovering airborne infectious viruses as it may cause desiccation and structural damage to the viral particles (Verreault et al., 2008).

Finally, large volumes samplers (LVS) using electrostatic precipitation to sample air have been employed for sampling of enterovirus (Fannin et al., 1985; Moore et al., 1979; Teltsch and Katzenelson, 1978). This type of device can draw up to 10,000 L air per minute by charging particles using a high-voltage corona. The charged particle will be driven to a collection surfaces by electrostatic interactions (Laskin and Cowin, 2002; Verreault et al., 2008). A recirculating fluid is then used to wash of the precipitated viruses (Verreault et al., 2008). LVS are particularly practical for long time sampling which is necessary in case of low aerosol concentration and high variation in aerosol occurrence (Madsen and Sharma, 2008).

Table 2. Overview of methods used for sampling and recover airborne enteric viruses.

Sampler type	Collection medium/filter	Virus	Source	Sample volume	Sample processing	Detection	Reference
Solid Impactors							
Andersen sampler	Trypsose phosphate broth + gelatine	RV ^a , PV ^b	Artificial aerosolisation via nebuliser	28L		Cell culture	Ijaz et al. (1987)
SAS air sampler	Trypsose agar	enteroviruses	WWTP - stationary sampling	0.9m ³	AT dissolved with 3% beef extract; chloroform treatment	Cell culture + serum neutralisation identification	Carducci et al. (1995)
SAS air sampler	Trypsose agar	enteroviruses; reoviruses	WWTP - stationary sampling	1,800- 3,000L	AT dissolved with 3% beef extract; chloroform treatment	Cell culture + RT-PCR + PAGE identification	Carducci et al. (2000)
SAS air sampler	Low melting agarose (LMA)	NoV GI ^c	LMA plates artificially seeded with viral suspensions	3,000L	Direct nucleic acid extraction using NucliSense Lysis buffer (BioMérieux)	QRT-PCR	Ziros et al. (2011)
Impingers							
Multistage liquid impinger	Phosphate buffered saline	PV	Artificial aerosolisation via nebuliser	275L		Cell culture	De Jong et al. (1973)
AGI	Trypsose phosphate broth + antifoam	RV, PV	Artificial aerosolisation via nebuliser	5.6L		Cell culture	Sattar et al. (1984); Ijaz et al. (1985b); Ijaz et al. (1985a); Ijaz et al. (1987)
SKC Biosampler	Peptone buffer + antifoam agent B	NoV	Land application of biosolids	250L	Ultracentrifugation (Centriprep); Nucleic acid extraction (Qiagen kit)	Conventional RT-PCR	Brooks et al. (2005)
Filters							
Aerosol collection device	Filterite polypropylene filter (0.4µm) moistened with glycine	PV	Artificial aerosolisation after toilet flush	200L	Elution with glycine; acidification (pH 3.5), adsorption (filterite filter), elution with glycine (pH 10.0)	Cell culture	Wallis et al. (1985)
GSP sampler	Polycarbonate filter (1µm)	NoV GI	WWTP - personal dust filter from worker	475L	Direct nucleic acid extraction using NucliSense Lysis buffer (BioMérieux)	QRT-PCR	Uhrbrand et al. (2011)
3-piece cassette	Nucleopore polycarbonate filter (0.4µm)	Adv ^d ; enteroviruses	Paediatric department	28,800L	Elution with deionized water; Nucleic acid extraction (MagNA Pure)	QRT-PCR	Tseng et al. (2010)
Electrostatic precipitators							
LVS	Medium essential medium	EV ^e	Land application of treated wastewater	9,000-12,000L		Cell culture + serum neutralisation identification	Tetsch and Katzenelson (1978)
LVS	Brain-heart infusion broth + 0.1% Tween 80	enteroviruses	Land application of treated wastewater	1,440-2,340m ³	Dilution (Hanks balanced salt solution); two-phase polymer concentration (NaDS, PEG, NaCl)	Cell culture	Moore et al. (1979)
LVS	Hank balanced salt solution + nutrient broth	enteroviruses	WWTP - stationary sampling	400-600L	sonication; filtration (0.2µm fetal calf serum-pretreated membrane)	Cell culture + serum neutralisation identification	Famin et al. (1985)

^aRV: rotavirus; ^bPV: poliovirus; ^cNoV: norovirus; ^dAdv: adenovirus; ^eEV: echovirus

4.1.4 Nucleic acid Extraction

Following virus concentration and elution nucleic acid extraction and purification must be performed. For this a variety of protocols may be employed. When choosing an extraction protocol, two parameters have to be considered: recovery of the viral material and elimination of substances that can inhibit the detection assay. The latter are substances of a diverse nature and depend on the sample type and the method used to concentrate viruses from the sample matrix (Arnal et al., 1999). Salts, detergents, phenol, protein (e.g. beef extract), lipids, proteinase, and polysaccharides (e.g. glycogen in shellfish) have all been identified as inhibitors (Arnal et al., 1999; Atmar et al., 1993; Ikner et al., 2011; Wilson, 1997).

Most methods are based on either phenol-chloroform or guanidinium isothiocyanate extraction of the nucleic acids. A variation of the phenol-chloroform based method has been developed for extraction of NoV RNA from shellfish samples. In this method proteinase K is used for digestion of the viruses as well as the shellfish tissue, followed by phenol-chloroform extraction of the nucleic acids and precipitation with cetyltrimethylammonium bromide (CTAB) to remove polysaccharides and other inhibitors (Atmar et al., 1993). This procedure has been successfully applied for detection of NoV in shellfish in several studies (Atmar et al., 1993; Atmar et al., 1995; Le Guyader et al., 1996; Le Guyader et al., 2000; Uhrbrand et al., 2010) as well as in raspberries (Le Guyader et al., 2004a). However, most currently used protocols are variations of the method described by Boom et al. (1990) based on guanidinium isothiocyanate extraction followed by adsorption onto silica particles. Moreover, many of the commercially available extraction kits are based on similar chemistry systems. Examples of these are the column-based QIAamp and RNeasy kits from Qiagen or the semi-automatic NucliSens extraction kit from BioMerieux using paramagnetic silica beads. The latter has successfully been used in connection with recovery of NoV from shellfish (Le Guyader et al., 2009; Uhrbrand et al., 2010), water (Schultz et al., 2011a) and air (Uhrbrand et al., 2011).

4.2 Virus detection

Most enteric viruses can be detected by propagation in cell culture. However, detection of NoV has been problematic as cultivation of NoV until now has been unsuccessful. For many years the only technique available for studying NoV has been electron microscopy, but the method is relatively insensitive with a detection limit of approximately 10^6 particles per gram stool and requires skilled personnel and expensive equipment (Atmar and Estes, 2001). Several enzyme immunoassays (EIAs) for rapid detection of NoV have more recently been developed and are now commercially available. The newer generation of EIA kits has been reported to have a fairly good specificity for a range of NoVs and may be of use as a rapid screening test for clinical samples during NoV outbreak investigation (Costantini et al., 2010; Gray et al., 2007; Morillo et al., 2011). However, they lack sensitivity with an estimated detection limit of 10^4 to 10^7 particles per gram stool (Costantini et al., 2010; Kele et al., 2011). While such numbers can be obtained in clinical samples they are rarely present in contaminated food, water and environmental samples, where very few particles may be present and still constitute a risk. Consequently these methods are not suitable for testing food, water and air samples (Mattison and Bidawid, 2009).

Cloning and characterization of the NoV genome by Jiang et al. (1990) have led to development of new reagents and molecular methods for detection of NoV (Atmar and Estes, 2001). Efforts have especially concentrated on nucleic acids detection using reverse transcriptase-polymerase chain reaction (RT-PCR) and more recently real-time RT-PCR, which in the last decade has revolutionized nucleic acid detection due to high speed, sensitivity, reproducibility, minimization of contamination, and possibility to quantify the target organism (Bosch et al., 2011). This has made the real-time RT-PCR approach the prime choice for detection of NoV and other enteric viruses in drinking water, food, and environmental samples.

4.3.1 Real-time RT-PCR assays for detection of NoV

Numerous real-time RT-PCR assays for detection and quantification of NoV from stool, food, drinking water and environmental samples have been described in the literature. Although, several SYBR Green RT-PCR assays have been described (Laverick et al., 2004; Radin and D'Souza, 2011a; Radin and D'Souza, 2011b; Richards et al., 2004b; Richards et al., 2004a) detection of NoV is commonly performed using TaqMan-based real-time RT-PCR as the latter is generally more sensitive and specific due to the use of the target-specific probe in addition to more or less specific

primers (Trujillo et al., 2006). The majority of these TaqMan-based assays target the OFR1-ORF2 junction region, which has been identified as the most conserved region of the NoV genome. Indeed, several TaqMan-based assays using broadly reactive NoV GI and GII primers and probes targeting this region have been developed and evaluated (da Silva et al., 2007; Dreier et al., 2006; Höhne and Schreier, 2004; Jothikumar et al., 2005; Kageyama et al., 2004; Kageyama et al., 2003; Loisy et al., 2005; Pang et al., 2005; Park et al., 2011b; Schultz et al., 2011b; Svraka et al., 2007). In addition, a few TaqMan-based assay have been developed for detection of NoV GIV (Logan et al., 2007; Trujillo et al., 2006).

Currently, a TaqMan-based RT-PCR assay established by the European standardization group (CEN/TC 275/WG6/TAG4) is being assessed as a future standard in relation to detection of NoV in foodstuff and bottled water. The TaqMan-based assay is, with minor modifications, identical to the assay described by Le Guyader et al. (2009) and employs a combination of previously developed ORF1-ORF2 junction region primers and probes for NoV GI (da Silva et al., 2007; Svraka et al., 2007) and NoV GII (Kageyama et al., 2003; Loisy et al., 2005). In an evaluation on 42 clinical samples positive for NoV the assay was found to detect NoV with 100% specificity in all samples (Butot et al., 2010). Furthermore the assay has been successfully used for quantitative detection of NoV in food and environmental samples containing low viral levels (Le Guyader et al., 2009; Uhrbrand et al., 2011).

4.4 Quality control and interpretation of results

RT-PCR is an extremely sensitive technique known to be vulnerable to cross-contamination events within the laboratory and to matrix interference causing RT-PCR inhibition (Lees and CEN, 2010). Furthermore contamination of the sample or loss of viruses can also occur during sample treatment prior to RT-PCR detection. Consequently both false positive and false negative results may occur. Therefore it is essential to include controls that can verify that the analytical results are reliable. Incorrect performance during either sample treatment or RT-PCR detection can be identified by inclusion of both negative and positive process controls and amplification controls, respectively (Diez-Valcarce et al., 2011a).

The incorporation of a positive process control will verify that the pre-amplification sample treatment has functioned correctly, and identify those samples in which the sample treatment has failed. In addition this positive process control can be used for determination of

recovery efficiency of the method. The positive process control must be added to samples at the start of the analysis and assayed in parallel with the target virus. This positive process control should consist of a non-target virus with similar characteristics as the virus of interest and must not be found naturally in the samples (Diez-Valcarce et al., 2011a). Mengovirus (MC₀) (Costafreda et al., 2006), MNV (Diez-Valcarce et al., 2011a) and FCV (Mattison et al., 2009) have been proposed as process controls. However the latter has been reported to be an inappropriate surrogate for NoV in acidic conditions (Cannon et al., 2006). A negative process control must also be included and taken through the entire concentration, extraction procedure and analysis in order to verify that the samples have not been contaminated by sample treatment reagents, equipment or handling (D'Agostino et al., 2011; EFSA Panel on Biological Hazards (BIOHAZ), 2011).

In real-time RT-PCR detection assays negative and positive amplification controls should also be included in each run to rule out contamination of the PCR reagents and to verify amplification of the target sequence. In addition performance of the detection assay can be controlled by including either an internal or external amplification control (IAC or EAC) which functions as a RT-PCR inhibition control (D'Agostino et al., 2011). A few papers describing the construction of IACs for detection of NoV have recently been published (Diez-Valcarce et al., 2011b; Gregory et al., 2011; Stals et al., 2009).

One of the major limitations of using RT-PCR for detection of viruses is the inability to discriminate between infectious and noninfectious viruses (Bosch et al., 2011). The infection ability of viruses found positive by RT-PCR in samples is still questioned and the correlation between viral particles and genome copies is uncertain. Hence, when interpreting RT-PCR results the possibility of potentially overestimating the number of infectious particles should be considered (Li et al., 2011b). To overcome this limitation various approaches to differentiate between infectious and noninfectious RNA viruses have been evaluated. These approaches include treatment with the DNA intercalating dyes ethidium monoazide (EMA) or propidium monoazide (PMA) in conjunction with RT-PCR (Kim et al., 2011; Parshionikar et al., 2010), pretreatment with proteinase and RNase in order to degrade the RNA genomes originating from damaged viral capsids (Baert et al., 2008c; Nuanualsuwan and Cliver, 2002), and binding-based RT-PCR where infectious virus particles are collected prior to RT-PCR through attachment to a receptor on a cell surface (Li et al., 2011b). However, despite these efforts no ideal approach has yet been found.

Chapter 5

Inactivation of norovirus

5 Inactivation of norovirus

Viruses are obligate intracellular parasites that can only replicate in a suitable living host. As a result, viruses cannot multiply in the environment or foods, so the traditional factors used to control bacterial levels in food systems (e.g., low pH, lowered temperature or reduced water activity) are ineffective as barriers to viral hazards (Grove et al., 2006). Alternative methods for the inactivation of NoV are therefore needed. However, studying the inactivation of NoV has been hampered by the lack of methods for cultivation of human NoV. Inactivation studies have therefore had to rely on the use of cultivable surrogates believed to have similar survival characteristics as NoV.

Most studies on the survival of human NoV have used related viruses such as FCV and MNV. FCV belongs to the genus *Vesivirus* in the family *Caliciviridae* and shares similarities in primary sequence and genomic organisation with human NoV (Grove et al., 2006). Based on similarity of the genome organisation as well as physicochemical properties FCV is believed to be an adequate model for human NoV (Huffman et al., 2003). However, since FCV is transmitted by the respiratory route, it may not predict human NoV environmental stability or inactivation accurately. Instead MNV has been suggested as a better surrogate due to genetic relatedness of MNV and human NoV and ability to survive under gastric pH levels (Cannon et al., 2006). Alternatively, bacteriophages, such as MS2, which similar to NoV is adapted to the gastrointestinal tract and therefore is believed to share physical properties with NoV, can be used as surrogates (Dawson et al., 2005; Dore et al., 2000). In addition the stability of NoV can be studied more directly by using recombinantly expressed monomers self-assembled into virus-like particles (VLPs) with well defined icosahedral structure. These NoV-VLPs constitute very simple and attractive models to study assembly, stability and unfolding of the viral capsid under different environmental conditions, such as pH and temperature (Ausar et al., 2006).

5.1 Stability of NoV in the environment

Due to the lack of cell culture system for NoV there is no precise information on the stability of NoV on food or in the environment and only a few pieces of direct evidence, based on experiments involving human volunteers, are available.

Being an enteric virus, NoV is able to resist the harsh conditions in the gastrointestinal tract, such as low pH and high bile concentrations (Duizer et al., 2004). In a human challenge study NoV has been found to remain infective, producing gastroenteritis after exposure to pH 2.7 for 3

hours (Pirtle and Beran, 1991). Moreover, NoV-VLPs have been demonstrated to be highly stable in the pH range of 3-7, while reversible capsid dissociation occurs at alkaline pH (Ausar et al., 2006).

Circumstantial information from outbreaks has shown that NoV persists well in the environment and can remain infective on fresh produce, within shellfish and on inanimate surfaces for several days (EFSA Panel on Biological Hazards (BIOHAZ), 2011). Moreover NoV can survive chilling and freezing and numerous outbreaks have been related to consumption of frozen raspberries contaminated with NoV. Indeed, freezing is believed to have minimal effect on the infectivity of NoV as no reduction in infectivity of the NoV surrogate MNV seeded on spinach and onions was found after storage at -20°C for 6 months (Baert et al., 2008b). Human challenge studies have found that NoV spiked into groundwater remained infectious after storage at room temperature in the dark for at least 61 days. Moreover, after 1266 days NoV RNA within intact capsids were detected in the groundwater after RNase treatment. There was no significant log₁₀ reduction throughout 427 days and a significant 1.1-log₁₀ reduction by day 1266 (Seitz et al., 2011). Detection of NoV RNA enzymatically pretreated to distinguish non-infective from putative infective NoV particles has also shown that NoVs can persist at 7°C in high relative humidity for 49 days on stainless steel and at least 56 days on PVC. At 20°C NoV persisted on both test surfaces at low and high humidity for 7 and 28 day, respectively (Lamhoujeb et al., 2009).

5.2. Heat treatment

NoV can be inactivated by thermal treatment which will cause capsid protein unfolding (Crocini et al., 2012). Using NoV-VLPs Ausar et al. (2006) showed the NoV capsid to undergo structural changes at the secondary, tertiary, and quaternary structural levels when exposed to temperature changes. The NoV-VLPs were demonstrated to be highly stable up to 55°C, while changes in the quaternary structure characterized by a loss of continuity in the icosahedral capsid were observed above 60°C.

To examine thermal inactivation of NoV several studies using NoV surrogates have been conducted (Table 3). Thermal inactivation has been found to be temperature and time-dependent. Increasing inactivation of both CaCV and FCV has been found to take place between 37° and 100°C, while long-term survival was observed at temperatures below 20°C (Duizer et al., 2004). Nevertheless, the exact temperature and time needed to completely inactivate NoV is

somewhat unclear as there are some discrepancies in the literature. At 50°C 1- \log_{10} reduction in FCV titer has for instance been reported to occur after 15 min by Buchow et al. (Buckow et al., 2008) and after approximately 51 min by Gibson and Schwab (2011b). The inconsistencies may to some extent be due to differences in the methodologies used in the studies (Gibson and Schwab, 2011b). The effect of thermal treatment also seems to be dependent on the NoV surrogate used. MNV has in some studies been found to be more resistant to heat treatment at moderate temperatures and thus be a more conservative surrogate than FCV. A 1- \log_{10} reduction of FCV and MNV in PBS has for example been found to take place at 37°C after 599 min and 1440 min and at 50°C after 51 and 105 min, respectively (Gibson and Schwab, 2011b). At higher temperatures the difference in the efficacy of heat treatment on the different NoV surrogates appears to be less pronounced as FCV and MNV were found to be reduced with 1- \log_{10} at 60°C after 15.1 min and 14.1 min in PBS and at 70°C in cell culture medium after 7 sec and 10 sec, respectively (Cannon et al., 2006; Gibson and Schwab, 2011b). Finally, the efficacy of heat treatment has been found to be matrix specific. In food the lipid, protein and sucrose content may affect virus inactivation to a great degree supposedly through protection of cell receptors or through formation of viral aggregates (Crocì et al., 2012). Indeed, Crocì et al. (2012) have shown the mussel matrix to play a protective role against heat inactivation. Hence caution should be taken when extrapolating virus inactivation data.

It is still uncertain whether NoV will be inactivated completely in many pasteurization processes. Based on heat inactivation studies on FCV and MNV in cell culture medium Cannon et al. (2006) concluded that both low-temperature pasteurization by the batch method (63°C for 30 min), and high-temperature pasteurization by the classical method (72°C for 2 min) or the continuous method (72°C from 15 sec) would most likely result in complete inactivation, unless the initial virus concentration level was high (>4 \log_{10}). When present in a raspberry puree, MNV was reduced with less than 3 \log_{10} after high-temperature pasteurization (72°C for 15 sec), suggesting that the risk of NoV infection remains associated with the pasteurized raspberry puree if a high initial contamination load is present (Baert et al., 2008a). Currently, boiling at 100°C for minimum 1 minute is recommended by the Danish authorities for high-risk products such as raspberries (Anon, 2011b) as this has been found to completely inactivate both FCV and HAV (Duizer et al., 2004; Koopmans and Duizer, 2004). Unfortunately, such a treatment will result in an unwanted loss in quality of the food product.

Table 3. The efficacy of heat treatment to inactivate norovirus surrogates.

Virus	Treatment	Matrix	Reduction (Log₁₀)^a	Reference
FCV ^b	37°C for 599 min	PBS ^c	1	Gibson and Schwab (2011b)
	50°C for 15 min	Cell culture medium	1	Buckow et al. (2008)
	50°C for 50.6 min	PBS	1	Gibson and Schwab (2011b)
	56°C for 1 min; 3 min; 60 min	Cell culture medium	0; 0; 7.5*	Doultree et al. (1999)
	56°C for 6.7 min	Cell culture medium	1	Cannon et al. (2006)
	60°C for 6 min; 15 min	Mussels	1; 2.2	Croci et al. (2012)
	60°C for 15.1 min	PBS	1	Gibson and Schwab (2011b)
	63°C for 25 sec	Cell culture medium	1	Cannon et al. (2006)
	70°C for 1 min; 3 min; 5 min	Cell culture medium	3; 6.5; 7.5*	Doultree et al. (1999)
	70°C for 90 sec	Cell culture medium	6	Buckow et al. (2008)
	72°C for 7 sec	Cell culture medium	1	Cannon et al. (2006)
	80°C for 3 min	Mussels	2.2	Croci et al. (2012)
	95°C for 2.5 min (Steam blanching)	Herbs	3-4	Butot et al. (2009)
	100°C (Boiling) for 1 min	Cell culture medium	7.5*	Doultree et al. (1999)
	100°C (Boiling) for 0.5 min; 1 min	Cockles	1.7; 4.5*	Slomka and Appleton (1998)
FCV; CaCV ^c	37°C for 1440 min	Cell culture medium	3	Duizer et al. (2004)
	56°C for 8 min	Cell culture medium	3	Duizer et al. (2004)
	71.3°C for 1 min	Cell culture medium	3	Duizer et al. (2004)
NV ^d	37°C for 769 min	PBS	1	Gibson and Schwab (2011b)
	50°C for 106 min	PBS	1	Gibson and Schwab (2011b)
	56°C for 3.5 min	Cell culture medium	1	Cannon et al. (2006)
	60°C for 14.1 min	PBS	1	Gibson and Schwab (2011b)
	63°C for 25 sec	Cell culture medium	1	Cannon et al. (2006)
	63°C for 42 sec; 5 min	Milk	1; 3.5*	Hewitt et al. (2009)
	63°C for 54 sec; 10 min	Water	1;3.3	Hewitt et al. (2009)
	65°C for 30 sec	Raspberry puree	1.9	Baert et al. (2008a)
	72°C for 10 sec	Cell culture medium	1	Cannon et al. (2006)
	72°C for < 18 sec; 1 min	Water	1;3.5*	Hewitt et al. (2009)
	72°C for 30 sec; 1 min	Milk	1;3.5*	Hewitt et al. (2009)
	75°C for 15 sec	Raspberry puree	2.8	Baert et al. (2008a)
	80°C for 2.5 min	Cell culture medium	6.5	Baert et al. (2008c)
	90°C for 3 min	Soft-shell clams	5.5*	Sow et al. (2011)

^aLog₁₀ reduction in the infectivity; ^bFCV: feline calicivirus; ^cCaCV: canine calicivirus; ^dMNV: murine norovirus; ^ePBS: Phosphate buffered saline; *Complete inactivation.

5.3. High hydrostatic pressure treatment

High hydrostatic pressure (HHP) is promising as an alternative technique for inactivation of NoV.

HHP is a non-thermal process that has been successfully used to inactivate bacterial pathogens and

spores in foods. HHP has the unique advantage that pressure acts uniformly throughout a food regardless of size, shape, and geometry (Lou et al., 2011) and the effects of HHP the sensory qualities of the food, such as colour and texture, have been reported to be less severe than those experienced using thermal treatments (Kovac et al., 2010).

In recent years numerous studies have been conducted on the efficiency of HHP treatment on NoV surrogates (Buckow et al., 2008; Chen et al., 2005; Grove et al., 2008; Kingsley et al., 2002; Kingsley et al., 2006; Kingsley and Haiqiang, 2008; Kingsley et al., 2007; Kovac et al., 2012; Lou et al., 2011; Murchie et al., 2007; Sharma et al., 2008). Virus inactivation by HHP is believed to stem from disruption of non-covalent bonds, such as ionic, hydrophobic and hydrogen bonds. This causes damage to the quaternary and tertiary structures of the viral proteins impairing functions of the capsid such as attachment, receptor binding and virus entry (Lou et al., 2011).

The effect of the HHP treatment on viruses has been found to be affected by processing parameters such as temperature, time and pressure. The degree of inactivation of virus increases with increasing pressure and time, while the effect of temperature on HHP virus inactivation varies depending on virus type (Kovac et al., 2010). FCV has been reported to be most resistant to HHP at 20°C with temperature above or below this value significantly increasing inactivation of FCV (Chen et al., 2005). MNV has likewise been found to be more susceptible to HHP at 5°C than at 20°C resulting in a log₁₀ reduction of MNV stock after 5 min treatments at 350 MPa of 5.56 and 1.79, respectively (Kingsley et al., 2007). However, cooler temperatures have not been found to enhance inactivation of HAV (Kingsley et al., 2006).

The efficacy of virus inactivation by HHP has also been found to be dependent on the matrix in which the viruses are present as food constituents such as proteins, lipids, or carbohydrates can confer a protective effect (Kovac et al., 2010; Kovac et al., 2012). For instance, HHP treatment for 2 min. at 4°C and 350 MPa has been observed to result in a 6.0 and 8.1-log₁₀ reduction of MNV in a cell culture medium at pH 4.0 and pH 7.0, respectively, compared with only a 2.4, 2.2 and 2.4- log₁₀ reduction in fresh lettuce, freshly-cut strawberry and strawberry puree, respectively (Lou et al., 2011). Similarly HHP treatment for 5 min. at 20°C and 250 MPa was found to result in a log₁₀ reduction of FCV of 3.8, 1.4 and 1.7 when present in cell culture medium, mussels and oysters, respectively (Murchie et al., 2007). Hence, the effect of HHP should be carefully studied in all matrices, to which HHP could potentially be applied. Moreover, as the effect of HHP on enteric viruses has been reported to be diverse (Kovac et al., 2012), the possibility of difference in effect of HHP on NoV and NoV surrogates should be considered. Indeed, a 4-log₁₀

reduction of MNV in oysters after 5 min at 5°C and 400 MPa obtained in a study by Kingsley et al. (2007) indicated that MNV inactivation could perhaps be sufficient at 400 MPa. Nevertheless, a clinical trial showed that HHP treatment of NoV seeded oysters for 5 min at 400 MPa and 6°C was insufficient to prevent NoV infections in humans. At 600 MPa NoV was, however, found to be completely inactivated (Leon et al., 2011).

5.4 Other treatments

The efficacies of a range of other treatments for inactivation of NoV on food have also been studied and include irradiation, ultrasound and washing with chemicals.

Inactivation of NoV surrogates has been studied using both UV light and gamma irradiation. The efficacy of UV light treatment at a dose of 40 mW s/cm² was dependant on matrix as a 3.5, 2.5 and 1.1-log₁₀ reduction of FCV was achieved when present on lettuce, green onions and strawberries, respectively (Fino and Kniel, 2008). Thus the use of UV may be more suitable for some food types than other. In addition FCV has been shown to be more susceptible to UV treatment than MNV (Park et al., 2011a) and caution should therefore be taken when interpreting the effect of UV on NoV from these FCV results. Gamma irradiation with 0.5 kGy has been found to result in a 3-log₁₀ reduction of FCV titer when present in a low protein-containing solution, but little effect of was seen in a high-protein containing solution (De Roda Husman et al., 2004). Furthermore MNV and NoV-VLPs have been found to be resistant to gamma irradiation when present on fresh produce with < 2-log₁₀ reduction observed on spinach, lettuce and strawberries at the maximum dose of 4 kGy currently approved by the US Food and Drug Administration (FDA) (Feng et al., 2011). Gamma irradiation was therefore found to be unsuited for NoV inactivation in food.

High-intensity ultrasound (HIUS) with a frequency of 750 kHz has been found to reduce the infectivity of FCV, MNV and MS2 when present in PBS presumably due to structural damage of capsid protein, viral coat, or host receptor recognition sites. However the effectiveness of HIUS was found to depend on the virus type, initial titer of the viruses, and the virus suspension solution. At an initial titer of 4 log₁₀ in PBS FCV, MS2 and MNV required treatment for 5, 10 and 30 min, respectively, for complete inactivation, yet in orange juice FCV required treatment for 15 min for complete inactivation and only a 1.6-log₁₀ reduction of MNV was observed after 30 min. Hence HIUS alone was not found to be sufficient for inactivation of NoV in food although HIUS

may have a potential in combination with secondary hurdle approaches such as heat or pressure (Su et al., 2010).

Finally, inactivation of NoV on fresh produce by washing with water supplemented with chemicals such as chlorine, hydrogen peroxide and peroxyacetic acid has been studied. A treatment of 200 ppm sodium hypochlorite was found to result in an additional reduction of MNV present on lettuce of 1 log compared with washing with tap water, which alone resulted in approximately 1- \log_{10} reduction (Baert et al., 2009b). However, in another study sodium hypochlorite in this concentration was found not to give additional reduction in FCV on strawberries and lettuce compared to washing with tap water (Gulati et al., 2001). High chlorine concentration would therefore be required to achieve a 2 to 3- \log_{10} reduction of NoV on fresh produce (Baert et al., 2009a). Whereas washing with 150 ppm peroxyacetic acid resulted in a 1 and 2- \log_{10} reduction of FCV on strawberries and lettuce, respectively, compared with water (Gulati et al., 2001), washing with 2.5% hydrogen peroxide was found to be ineffective on MNV on lettuce as no difference in reduction was seen in lettuce treated with hydrogen peroxide and lettuce washed with tap water (Li et al., 2011a).

Chapter 6

Manuscript I

**Evaluation of a rapid method for recovery of norovirus and hepatitis A virus from oysters
and blue mussels**

Katrine Uhrbrand, Mette Myrmel, Leena Maunula, Kirsti Vainio, Ramona Trebbien, Birgit Nørrung
and Anna Charlotte Schultz

Published in Journal of Virological Methods 2010, 169:70-78



Contents lists available at ScienceDirect

Journal of Virological Methods

journal homepage: www.elsevier.com/locate/jviromet

Protocol

Evaluation of a rapid method for recovery of norovirus and hepatitis A virus from oysters and blue mussels

Katrine Uhrbrand^a, Mette Myrmel^b, Leena Maunula^c, Kirsti Vainio^d, Ramona Trebbien^a, Birgit Nørrung^a, Anna Charlotte Schultz^{a,*}^a Division of Microbiology and Risk Assessment, National Food Institute, Technical University of Denmark, Mørkhøj Bygade 19, DK-2860 Søborg, Denmark^b Department of Food Safety and Infection Biology, Norwegian School of Veterinary Science, Oslo, Norway^c Department of Food Hygiene and Environmental Health, University of Helsinki, Helsinki, Finland^d Department of Virology, Norwegian Institute of Public Health, Oslo, Norway

A B S T R A C T

Article history:

Received 11 March 2010

Received in revised form 18 June 2010

Accepted 28 June 2010

Available online 13 July 2010

Keywords:

Norovirus

Hepatitis A virus

Oyster

Mussel

Virus recovery

Real-time RT-PCR detection

Foodborne outbreaks caused by noroviruses (NoVs) and hepatitis A virus (HAV) are often linked to consumption of contaminated shellfish. The objective of this study was to identify an appropriate virus recovery method for real-time reverse transcriptase (RT)-PCR detection and subsequently to evaluate this method on shellfish bioaccumulated with virus in a collaborative study. Five methods were compared for recovery of NoV GII.7 and feline calicivirus from spiked digestive tissue of oysters and mussels. A method based on proteinase K digestion followed by NucliSENS miniMAG extraction was found to be the most efficient with a 50% limit of detection (LOD₅₀) of 62 and 12 RT-PCR U/1.5 g digestive tissue for NoV GII.7 in oysters and mussels, respectively. Evaluation of the method in four laboratories found the percentage of sensitivity, based on low/high levels of virus bioaccumulated in oysters, to be 33/80 for NoV GI.3b, 13/92 for NoV GII.4 and 50/42 for HAV. A specificity of 100% was found for all three viruses in non-bioaccumulated oysters. As process control Mengovirus (vMC₀) showed an average recovery of 1.8% from oysters and 1.2% from mussels. The study demonstrates that this recovery method can be useful for harmonized data generation and routine viral analyses of shellfish.

© 2010 Elsevier B.V. All rights reserved.

1. Introduction

Noroviruses (NoVs) and hepatitis A virus (HAV) are the most common causes of acute, non-bacterial gastroenteritis and hepatitis, respectively, worldwide. The viruses can be readily transmitted via the fecal-oral route by direct contact or indirectly via contaminated water, food, or from the environment (Koopmans and Duizer, 2004).

Numerous outbreaks of viral disease have been associated with the consumption of raw or undercooked bivalve molluscan shellfish (from here on, referred to as shellfish) harvested in fecal-polluted waters (Le Guyader et al., 1996; Lees, 2000; Shieh et al., 2000). Shellfish are filter-feeders and can concentrate and retain viruses, such as NoV and HAV, from the surrounding polluted waters, thus becoming vehicles of transmission to humans (Lees, 2000; Shieh et al., 2000).

Norovirus cannot be propagated using a conventional cell culture method and HAV grows poorly, thus detection of both NoV and HAV in shellfish rely on molecular biological methods such as

reverse transcription-polymerase chain reaction (RT-PCR) (Comelli et al., 2008; Le Guyader et al., 2000). However, shellfish constitute a difficult and variable matrix, known to cause amplification inhibition (Lowther et al., 2008). Effective preliminary sample treatment steps, such as release and concentration of viruses from the shellfish tissue and RNA extraction/purification are therefore essential for final PCR accuracy and reproducibility (Le Guyader et al., 2000). Numerous recovery methods have been developed for this purpose (Atmar et al., 1995; Beuret et al., 2003; de Roda Husman et al., 2007; Jothikumar et al., 2005; Le Guyader et al., 2006b; Lees et al., 1994; Mullendore et al., 2001; Myrmel et al., 2004) and some method comparisons have been performed (Comelli et al., 2008; de Roda Husman et al., 2007; Le Guyader et al., 2009; Schultz et al., 2007). However, direct comparison of the performance of the various protocols is not straight forward as different viral strains, shellfish species and detection procedures have been employed.

The European Committee on Normalization (CEN) has an expert working group (CEN/TC 275/WG6/TAG4) addressing the development of a horizontal EU standard method for the detection of NoV and HAV in foodstuffs and bottled water. However, no methods have been sufficiently validated for the final standard, and it is likely that the protocols have to be matrix specific.

* Corresponding author. Tel.: +45 3588 7000; fax: +45 3588 7028.

E-mail address: acsc@food.dtu.dk (A.C. Schultz).

Table 1

Evaluation of methods (A–E) for qualitative recovery of NoV GII.7 and FCV spiked on digestive tissue from oysters and mussels. Viral RNA was recovered on two distinct occasions and detection of viruses by real-time RT-PCR was carried out in duplicates, resulting in four determinations for each type and load of virus.

Virus	Spiked concentration (RT-PCR U/1.5 g digestive tissue)	No. of positive RT-PCR reactions/Total no.												
		Oysters Recovery method						Mussels Recovery method						
		A ^a	B ^a	C ^a	D ^a	E ^a	E ^b	A ^a	B ^a	C ^a	D ^a	E ^a	E ^b	
NoV GII.7	1.0E+04	4/4	2/4	4/4	1/4	4/4	4/4	4/4	4/4	2/4	2/4	2/4	4/4	4/4
	1.0E+03	2/4	4/4	1/4	3/4	4/4	4/4	2/4	2/4	2/4	2/4	2/4	4/4	4/4
	1.0E+02	2/4	3/4	0/4	0/4	3/4	4/4	3/4	2/4	2/4	1/4	1/4	4/4	4/4
	1.0E+01	1/4	1/4	1/4	1/4	1/4	4/4	1/4	2/4	1/4	1/4	1/4	2/4	4/4
	1.0E+00	0/4	0/4	1/4	1/4	1/4	1/4	1/4	1/4	0/4	1/4	1/4	1/4	3/4
	1.0E–01	NA ^c	NA	NA	NA	0/2	0/2	NA	NA	NA	NA	NA	0/2	0/2
	LOD ₅₀ ^d	621	86	796	554	62	2	216	1128	3236	2164	12	1	
	Mean ΔCt ^e (relative to E ^a)	6.8	7.1	2.4	4.3	0	–5.0	7.0	7.8	7.8	8.4	0	–2.9	
FCV	1.0E+06	NA	2/2	4/4	1/4	4/4	4/4	NA	2/2	3/4	1/4	4/4	4/4	
	1.0E+05	NA	2/2	0/4	0/4	4/4	4/4	NA	2/2	2/4	0/4	4/4	3/4	
	1.0E+04	NA	2/2	2/4	0/4	4/4	4/4	NA	0/2	0/4	0/4	4/4	4/4	
	1.0E+03	4/4	2/2	0/4	0/4	4/4	4/4	2/4	1/2	0/4	0/4	4/4	4/4	
	1.0E+02	4/4	2/4	0/4	0/4	4/4	3/4	3/4	0/4	0/4	0/4	2/4	3/4	
	1.0E+01	2/4	0/2	NA	NA	0/4	0/4	0/4	0/2	NA	NA	1/2	2/2	
	1.0E+00	0/4	0/2	NA	NA	NA	NA	0/4	0/2	NA	NA	NA	NA	
	LOD ₅₀ ^d	17	165	164,872	228,356	32	119	621	16,487	465,444	228,356	22	1	
Mean ΔCt ^e (relative to E ^a)	1.0	4.4	12.8	15.6	0	–1.1	3.3	8.8	11.9	15.6	0	–0.7		

^a Two-step TaqMan RT-PCR.

^b One-step TaqMan RT-PCR.

^c NA, not analysed.

^d LOD₅₀, detection level (RT-PCR U/1.5 g digestive tissue) at which 50% of replicates are positive.

^e Mean ΔCt, mean difference in average Ct-values obtained using either method A, B, C, D and E^b relative to average Ct-values obtained with method E^a.

As oysters (*Ostrea edulis*) and blue mussels (*Mytilus edulis*) constitute the majority of the Nordic shellfish production, the objective of this work was to conduct a comparative study between five methods to identify the most efficient recovery method for TaqMan-based RT-PCR detection of NoV in these matrices. An additional objective was to evaluate the ability of the identified method to robustly recover bioaccumulated NoV and HAV in shellfish in a collaborative study with four participating laboratories.

2. Materials and methods

2.1. Viruses used for spiking and bioaccumulation

Stocks of NoV GII.7 and FCV strain F9 (ATCC VR-782) were used for spiking experiments in the comparative study while NoV GI.3b, NoV GII.4 and HAV (ATCC HM175/18f, kindly provided by Dr. De Medici, Istituto Superiore di Sanità (ISS), Rome, Italy) were used for bioaccumulation experiments. Recombinant Mengovirus, vMC₀, (ATCC VR-2310, kindly provided by Prof Albert Bosch, University of Barcelona, Spain) was used as a process control in the collaborative study.

The three NoV-positive stool samples were stored at –70 °C and had previously been genotyped (Kojima et al., 2002) and quantified by end point titration to contain 1×10^7 RT-PCR U/ml for NoV GII.7 and by plasmid standard curve determination to contain 3×10^7 and 5×10^6 copies/ml for NoV GI.3b and GII.4, respectively.

Reference stocks of FCV, HAV and vMC₀ were propagated in Crandell–Reese feline kidney (CRFK) cells (ATCC CCL-94) (Bidawid et al., 2003), Frp/3 derived from FRhK-4 cells (de Medici et al., 2001; Venuti et al., 1985) and HeLa cells (ATCC CCL-2) (Martin et al., 1996), respectively. Titration (Reed and Muench, 1938) displayed the following titers; FCV: 1×10^7 TCID₅₀/ml, HAV: 2×10^7 TCID₅₀/ml and vMC₀: 1×10^8 TCID₅₀/ml.

Tenfold serial dilutions of viruses were made in phosphate-buffered saline (PBS; 145 mM NaCl, 7.7 mM Na₂HPO₄, and 2.3 mM NaH₂PO₄, pH 7.4) just prior to spiking experiments and bioaccumulation.

2.2. Comparative study

2.2.1. Artificial contamination of shellfish by spiking

Oysters (*Ostrea edulis*) and blue mussels (*Mytilus edulis*) harvested from class A areas (Anon, 2010) in Denmark were collected from the Danish market during 2003–2004. The stomach and digestive diverticula (digestive tissue) were isolated by dissection, pooled and divided into 1.5-g aliquots and stored frozen at –20 °C until use. All batches tested negative for natural content of NoV GI and GII according to the protocol described by Le Guyader et al. (2000) and RT-seminested PCR (Nishida et al., 2003) using the genogroup-specific primers COG1F/G1-SKR and G1-SKF/G1-SKR for NoV GI and COG2F/G2-SKR and G2-SKF/G2-SKR for NoV GII (Kageyama et al., 2003; Kojima et al., 2002).

For the spiking experiments, 1.5-g portions of digestive tissue isolated from oysters and mussels were spiked on two separate occasions with 10-fold dilutions of NoV GII.7 (10^{-1} to 10^4 RT-PCR U) and FCV (10^0 to 10^6 RT-PCR U) (Table 1). On each occasion, a non-spiked oyster and mussel sample were included as negative process controls.

2.2.2. Virus recovery methods

Five methods (A–E) were tested in laboratory 1 for their recovery of viral RNA in 1.5 g of spiked digestive tissue (Fig. 1). The extracted RNA obtained using the methods A–D was resuspended in 100 μl sterile water containing 100 U RNase inhibitor (Invitrogen, Taastrup, Denmark), while 100 μl of NucliSENS elution buffer (BioMerieux, Herlev, Denmark) was used in method E.

2.2.2.1. Method A. Virus elution, lysis and subsequent RNA extraction was carried out according to Jothikumar et al. (2005), but scaled up by the addition of lysis buffer to process the entire sample in one 50-ml Falcon tube. Briefly, digestive tissue was chopped using a razor blade, digested with proteinase K (30 U/mg; Finnzymes, Espoo, Finland) and the released viruses were separated from the tissue debris by centrifugation. RNA was extracted by adding 4.5 ml guanidine thiocyanate lysis buffer (Sigma–Aldrich, Brønby,

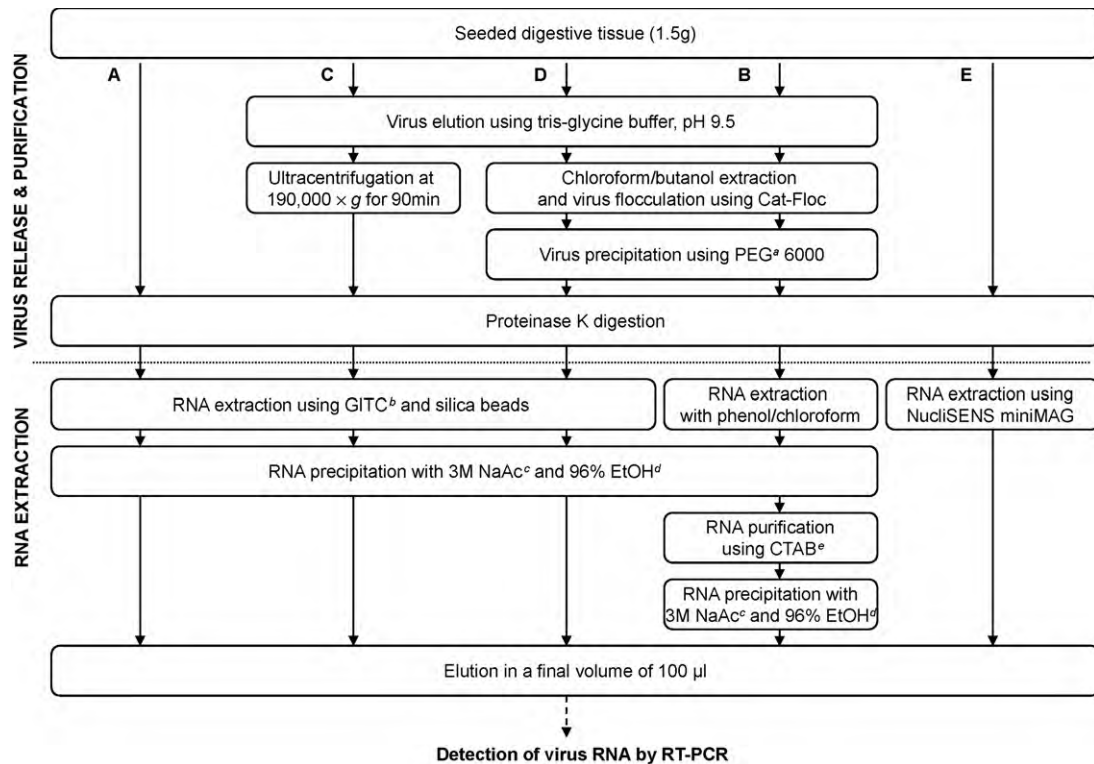

Fig. 1. Principles behind the five methods (A–E) for recovery of virus RNA from shellfish, compared in the present study. Method A (Jothikumar et al., 2005, modified); method B (Le Guyader et al., 2006a,b); method C (Myrmel et al., 2004, modified); method D (Le Guyader et al., 2000; Jothikumar et al., 2005); method E (Jothikumar et al., 2005, modified, in combination with NucliSENS RNA extraction, BioMerieux). ^a PEG, polyethylene glycol; ^b GITC, guanidium isothiocyanate; ^c NaAc, sodium acetate; ^d EtOH, ethanol; ^e CTAB, cetyltrimethylammonium bromide.

Denmark) and silica beads (Glassmilk, Anachem Ltd., Luton, UK) to the entire volume of supernatant. For the remaining steps of the RNA extraction, the protocol described by Jothikumar et al. (2005) was followed.

2.2.2.2. Method B. The shellfish samples were processed as described by Le Guyader et al. (2006b). Briefly, digestive tissue was homogenized, extracted with chloroform–butanol and treated with Cat-Floc (Calgon Corp., Ellwood City, PA, USA), followed by polyethylene glycol 6000 (Sigma, Brønby, Denmark) precipitation. The precipitated viral-containing pellet was digested by proteinase K and virus RNA was extracted using phenol–chloroform and cetyltrimethyl-ammonium bromide (CTAB) (USB, Cleveland, Ohio) as described by Le Guyader et al. (2006b).

2.2.2.3. Method C. Shellfish were processed using a slightly modified version of the method described by Myrmel et al. (2004). Briefly, digestive tissue was homogenized with a Potter Elmer homogeniser, diluted 1:1 with Tris–glycine buffer (pH 9.5, 0.1 M Tris, 0.05 M glycine, 0.15 M NaCl), mixed on a shaker at 150 rpm for 15 min at 4 °C and centrifuged at 10,000 × g for 15 min at 4 °C. The supernatant was ultracentrifuged at 190,000 × g for 90 min at 4 °C and the resulting pellet suspended in 300 µl of sterile water. Proteinase K digestion and RNA extraction was performed subsequently as described by Jothikumar et al. (2005).

2.2.2.4. Method D. Virus elution and lysis were carried out as in method B (Le Guyader et al., 2000). The virus-containing pellet was resuspended in 400 µl sterile water and RNA extracted using the up-scaled protocol of Jothikumar et al. (2005) as described for method A.

2.2.2.5. Method E. Virus elution and lysis were carried out according to Jothikumar et al. (2005). RNA was extracted from the supernatant after proteinase K digestion using the NucliSENS mini-MAG system (BioMerieux, Herlev, Denmark) according to the manufacturers' instructions with the following modification: the entire supernatant was incubated in 4.5 ml of NucliSENS lysis buffer (BioMerieux, Herlev, Denmark) for 10 min at room temperature followed by 10 min incubation after addition of 250 µl of NucliSENS magnetic silica (BioMerieux, Herlev, Denmark).

2.3. Collaborative study

2.3.1. Artificial contamination of shellfish by bioaccumulation

Oysters (*Ostrea edulis*) and blue mussels (*Mytilus edulis*) harvested from commercial class A areas (Anon, 2010) in Norway were collected from a wholesale dealer in April 2008. Shellfish were bioaccumulated on two separate occasions with two different levels of NoV GI.3b, NoV GII.4 and HAV in the water. On one occasion, 46 oysters and 100 mussels were used, while 42 oyster and 66 mussels were used on the other occasion. The shellfish were placed in an aerated aquarium filled with 35 l of fresh seawater (approximately 11 °C) collected from the outer area of the Oslofjord. The shellfish were acclimatised for 3 h and floating shellfish were removed prior to bioaccumulation. Suspensions of NoV GI.3b, GII.4 and HAV were added slowly to the water over a period of 35 min in either low (5.9×10^6 copies, 2.0×10^6 copies or 5.3×10^6 TCID₅₀) or high (2.9×10^8 copies, 9.8×10^7 copies or 2.6×10^8 TCID₅₀) amounts. Bioaccumulation was allowed to take place for 4–4.5 h. The shellfish were removed and divided into separate plastic bags (marked with a blinded code) containing 2–3 oysters or 3–4 mussels representing one sample. A total of 14 test samples, consisting of 12 positive

samples (6 oyster and 6 mussel samples, 3 of each bioaccumulated in high and low virus levels) and 2 negative samples (1 oyster and 1 mussel sample), were distributed on ice to each of the participating laboratories immediately after bioaccumulation. Upon arrival, the shellfish were stored at +4 °C and processed within 24 h.

2.3.2. Recovery of virus bioaccumulated in shellfish

For recovery of the virus bioaccumulated in oysters and mussels method E, previously described in Section 2.2.2.5, was employed.

2.4. Amplification and detection of viral RNA

For the comparison of recovery methods (A–E) a two-step TaqMan RT-PCR was used. In addition, a one-step TaqMan format was included for method E to evaluate the efficiency of the two detection assays. In the collaborative study, the one-step TaqMan format was applied.

2.4.1. Two-step real-time RT-PCR

The RT was performed on 5 µl RNA in a total reaction volume of 25 µl using the SuperScript III reverse transcriptase system (Invitrogen, Taastrup, Denmark) containing 2 µM of the reverse primer, 0.4 mM of each dNTP, 1× First-Strand buffer, 8 mM DTT and 40 U RNase inhibitor (Invitrogen, Taastrup, Denmark). The RT was carried out at 37 °C for 50 min followed by 15 min at 70 °C on a DNA Engine TETRAD2 Peltier thermal cycler (BIO-RAD, Copenhagen, Denmark). Real-time PCR was performed in duplicates on 2 µl of cDNA in a total reaction volume of 25 µl using TaqMan Universal PCR Master Mix (Applied Biosystems, Naerum, Denmark). For detection of NoV GII, the primers QNIF2/COG2R (500 nM of each) and the probe QNIFS (250 nM) (Kageyama et al., 2003; Loisy et al., 2005) were used, while FCV was detected using primers FCVf/FCVr (250 nM of each) and probe FCVp (250 nM) (Lowther et al., 2008). The real-time PCR was performed using ABI Prism 7900HT (Applied Biosystem, Naerum, Denmark) and the following cycling conditions: 2 min at 50 °C, 10 min at 95 °C and 50 cycles at 95 °C (15 s) and 60 °C (60 s). Fluorescence was measured at the end of each cycle.

2.4.2. One-step real-time RT-PCR

One-step real-time RT-PCR was performed in duplicates on 5 µl of RNA in a total volume of 25 µl using the RNA UltraSense one-step quantitative RT-PCR system (Invitrogen, Taastrup, Denmark). The NoV GII and FCV primers and probes were as described for the two-step RT-PCR (Section 2.4.1). The primers QNIF4/NV1LCR and probe NVGG1 were used for detection of NoV GI (da Silva et al., 2007; Svraka et al., 2007), HAV68/HAV240 and HAV150(–) for HAV (Costafreda et al., 2006) and Mengo110/Mengo 209 and Mengo 147 for vMC₀ (Costafreda et al., 2006). For all targets the concentrations of forward primer, reverse primer and FAM-labelled probe were 500, 900 and 250 nM, respectively. Buffer and enzymes were added at concentrations recommended by the manufacturer. The cycling conditions were: 15 min at 50 °C, 2 min at 95 °C and 45 cycles at 95 °C (15 s) and 60 °C (30 s). Fluorescence was measured at the end of each cycle. The real-time assay was performed on 96-well plate format of ABI Prism 7900HT (Applied Biosystems, Naerum, Denmark) by laboratory 1, 96-well plate format of Stratagene Mx3000 (Agilent Technologies, TX, USA) by laboratories 3 and 4 and on a 72-tube format of Rotorgene RG-3000 (Corbett, Sydney, Australia) by laboratory 2.

Each run included RNA transcripts of NoV GI.3b and NoV GII.4 and extracted RNA from HAV and vMC₀ as positive RT-PCR controls and water as negative controls.

2.5. Data analysis

2.5.1. Determination of a 50% limit of detection in the comparative study

In accordance with NordVal (Anon, 2009), a 50% limit of detection value (LOD₅₀) was calculated on the qualitative data obtained in the comparative study in order to evaluate the performances of the methods. Calculations of LOD₅₀ were based on the Spearman–Kärber method and express the viral concentration (RT-PCR U/1.5 g digestive tissue) that corresponds to a 50% probability of a positive result with the test method used. Calculation of LOD₅₀ requires a spiking level giving a 100% response. In cases where none of the spiking levels gave such a response, a spiking level 10 times the uppermost level giving a partial response was assumed to give a 100% response. For the non-spiked negative process controls, a concentration of 0.004 RT-PCR U/1.5 g digestive tissue was allocated.

2.5.2. Statistical analysis of Ct-values obtained in collaborative study

Analysis of variance was used to determine the statistical significance between Ct-values obtained in the collaborative study from shellfish bioaccumulated with low and high levels of viruses. Statistical analyses were carried out using a one-way analysis of variance in Microsoft Office Excel (Microsoft, Redmond, WA, USA). Results with *P* values of <0.05 were considered statistically significant.

2.5.3. Calculation of the percentage of sensitivity and specificity of the recovery method in the collaborative study

For the collaborative study, the real-time RT-PCR results from the participating laboratories were evaluated by laboratory 1. The results were partially analysed according to the recommendations from NordVal (Anon, 2009). The percentage of specificity was calculated for the shellfish samples not subjected to bioaccumulation (negative samples) by the following equation: $SP = (1 - (FP/N-)) \times 100\%$, where *SP* is the percentage of specificity, *FP* the number of false positive results and *N-* refers to the number of samples not bioaccumulated with virus (negative samples).

The percentage of sensitivity was calculated for each level of viral contamination by the following equation: $SE = (TP/N+) \times 100\%$, where *SE* is the percentage of sensitivity, *TP* the number of true positive results and *N+* refers to the number of viral contaminated samples.

2.5.4. Estimation of virus recovery in the collaborative study

The process control vMC₀ was used to estimate the virus recovery of method E in the collaborative study. The shellfish (1.5 g digestive tissue) bioaccumulated with virus were spiked with 10³ TCID₅₀ of vMC₀ after initial chopping, and the recovery was calculated from the number of TCID₅₀ detected in the shellfish extracts as a percentage to the number of spiked TCID₅₀. Quantification was performed using standard curves generated from 10-fold dilution series of vMC₀ RNA.

3. Results

3.1. Comparative study on spiked shellfish

Digestive tissue of oysters and blue mussels were spiked with NoV GII.7 and FCV and analysed on two distinct occasions using the five recovery methods (A–E). Virus recovery was evaluated qualitatively by a two-step TaqMan RT-PCR, in duplicates, resulting in four determinations for each type and load of virus (Table 1).

When estimating the recovery of NoV GII.7 RNA from spiked oyster digestive tissue by endpoint titration, methods C, D and E were found to be the most efficient, as 1 RT-PCR U was detected

in one out of four determinations. A slightly different pattern was seen when expressing the detection limit as LOD_{50} , which showed method E to be the most sensitive method followed by method B. In general, however, only method E gave consistent detection of oyster duplicates and showed a good correlation between levels of spiked NoV GII.7 and Ct-values (data not shown). The Ct-values were generally lower for method E than the Ct-values obtained by the other methods, as demonstrated by the mean difference in Ct-values for method E and the other methods (Table 1). A similar pattern was seen in the detection of spiked levels of NoV GII.7 in mussels, where method E resulted in lower Ct-values than the other methods. In mussels, methods A, B, D and E were all able to detect 1 RT-PCR U of spiked NoV GII.7 in at least one out of four determinations. However, calculation of LOD_{50} (Table 1) indicated that method E was the most sensitive followed by method A, and only method E resulted in consistent detection of duplicates and a good linear relation between Ct-values and viral loads (data not shown).

For the recovery of FCV in both oysters and mussels, methods A and E resulted in the best and most consistent performances (Table 1). In oysters, method A was able to detect 10 RT-PCR U in two out of four determinations, while method E allowed detection of 100 RT-PCR U in all four determinations. In mussels, method E was able to detect 10 RT-PCR U in one of two determinations while method A detected 100 RT-PCR U in three out of four determinations. Expression of the detection limit as LOD_{50} (Table 1) gave similar results.

Altogether, method E was found to be the most efficient method allowing an overall more sensitive and repeatable recovery of viral RNA from shellfish digestive tissue than the other four methods. Hence method E was chosen for the collaborative study on shellfish bioaccumulated with virus.

3.2. One-step versus two-step real-time RT-PCR

A two-step TaqMan real-time RT-PCR was used for virus detection during the evaluation of the five sample treatment methods (A–E). However, as advances in detection move towards the more simple one-step TaqMan format, this approach was also tested on virus RNA recovered by method E. Both assays resulted in repeatable NoV GII.7 and FCV detection showing good linearity with correlation coefficients (R^2) in the range 0.92–1.00, depending on shellfish matrix and virus type (Fig. 2). Generally, the one-step TaqMan assay showed a better linearity than the two-step TaqMan, and for NoV GII.7, the calculated amplification efficiencies (E_a) were slightly improved using the one-step TaqMan assay (Fig. 2). For these reasons, the one-step real-time RT-PCR assay was chosen for the collaborative study on shellfish bioaccumulated with virus.

3.3. Collaborative study on shellfish bioaccumulated with virus

All four participating laboratories had interpretable results for the recovery of NoV GI.3b, NoV GII.4 and HAV in both oysters and mussels using method E. The positive RT-PCR amplification controls had average Ct-values of 29.6 ± 1.4 (NoV GI.3b), 26.7 ± 1.8 (NoV GII.4) and 23.7 ± 2.4 (HAV). Moreover, recovery of the process control, vMC₀, was successful in all samples except for two mussel samples processed by laboratory 3, indicating a flaw in the sample treatment. Average Ct-values for vMC₀ were calculated to be 32.5 ± 1.5 for oysters and 33.6 ± 2.7 for mussels. The slightly high standard deviations observed for amplification and process controls can to some extent be explained by difference in PCR apparatus, baseline and threshold used in the four laboratories, since less significant standard deviations were found within each laboratory. Average recovery efficiencies for vMC₀ of $1.8\% \pm 2.4$ (ranging from 0.001 to 8.84%) in oysters and $1.2\% \pm 1.8$ (ranging from 0.08

to 7.61%) in mussels were calculated based on quantification using standard curves of vMC₀ extracted in each of the four laboratories. All standard curves showed good linearity with correlation coefficients (R^2) in the range 0.99–1.00 and amplification efficiencies (E_a) between 97 and 129% with the exception of one standard curve produced by laboratory 3, resulting in an E_a of 308%.

The mean Ct-values obtained for the various virus bioaccumulation levels were calculated (Table 2). As expected, significantly ($P \leq 0.05$) lower Ct-values were observed in both oyster and mussel samples bioaccumulated with high levels of virus compared with those bioaccumulated with low levels. One exception to this picture, however, was HAV in oysters, where slightly higher Ct-values for unknown reason were found for HAV bioaccumulated in high levels.

Assuming that all the shellfish regardless of species had an equal uptake of viruses during bioaccumulation, the percentages of specificity and sensitivity of method E on both oyster and mussel matrices were calculated (Table 2).

The sensitivity for NoV GI.3b detection was found to be 33.3 and 79.2% for oysters bioaccumulated with low and high levels of NoV GI.3b, respectively. For low and high levels of NoV GII.4 in oysters, the sensitivity was found to be 12.5 and 91.7%, respectively, while the sensitivity for low and high levels of HAV was found to be 50 and 41.7%, respectively. In the mussel samples bioaccumulated with NoV GI.3b, the sensitivity for both low and high levels of NoV GI.3b was 83.3%, while the sensitivity for NoV GII.4 was found to be 83.3 and 91.1% for low and high levels, respectively. Finally, the sensitivity for HAV bioaccumulated in mussels was found to be 54.2 and 83.3% in low and high levels, respectively.

Based on the oysters not subjected to bioaccumulation, the specificity of the method was found to be 100% for all three viruses in this matrix. In mussels, however, the samples not subjected to bioaccumulation tested positive for NoV GI in some laboratories and tested positive for NoV GII in all laboratories. Consequently, we were not able to calculate the percentage of sensitivity for this shellfish matrix. The Ct-values from the mussels that were not bioaccumulated were found to be significantly ($P < 0.05$) higher than the mussel samples bioaccumulated with low levels of NoV GI and NoV GII (Table 2). No contamination of the negative PCR and extraction controls was observed supporting the theory of natural contamination rather than cross-contamination.

In two of the mussel samples, which had been bioaccumulated with high levels of NoV GI.3 and HAV as well as low levels of NoV GII.4, one laboratory (laboratory 3) failed to recover the process control vMC₀. In these samples, the laboratory also failed to detect NoV GI.3b, NoV GII.4 and HAV, showing congruence between detection of the process control and the bioaccumulated viruses.

4. Discussion

Detection of viruses in shellfish is mainly hampered by the low viral load and the co-extraction of RT-PCR inhibitors. Hence, choosing an effective sample treatment prior to RT-PCR detection is essential. Numerous procedures for virus recovery have been described in the literature but there is a need for a standardized method.

Five methods (A–E) were compared qualitatively with regards to recovery of spiked NoV GII.7 and FCV from the digestive tissue of oysters and blue mussels. Method E had the overall best performance for both shellfish types and both virus strains with regards to sensitivity and repeatability. In addition, method E was the least time-consuming and labour-intensive method.

In method E, release and concentration of virus from the digestive tissue is obtained by simple chopping followed by proteinase K digestion and RNA extraction using a commercial

Table 2
Qualitative recoveries and mean Ct-values of NoV GI.3b, NoV GI.4 and HAV bioaccumulated in oysters (A) and mussels (B) tested in four laboratories using a protocol based on proteinase K treatment followed by RNA extraction using NucliSENS miniMAG (method E). For each level of bioaccumulation, viral RNA was extracted in triplicates and detected by RT-PCR in duplicates, resulting in six determinations for each shellfish matrix, virus type and bioaccumulation level. As negative control one sample of oyster or mussel not subjected to bioaccumulation was used.

Laboratory	NoV GI.3b				NoV GI.4				HAV			
	Not accumulated	Low level accumulation	High level accumulation	Total	Not accumulated	Low level accumulation	High level accumulation	Total	Not accumulated	Low level accumulation	High level accumulation	Total
(A) Recovery of virus bioaccumulated in oysters (no. of positive RT-PCR reactions/total no.)												
1	0/2	3/6	6/6	9/12	0/2	0/6	6/6	6/12	0/2	2/6	1/6	3/12
2	0/2	5/6	6/6	11/12	0/2	1/6	6/6	7/12	0/2	6/6	6/6	12/12
3	0/2	0/6	3/6	3/12	0/2	2/6	6/6	8/12	0/2	2/6	0/6	2/12
4	0/2	0/6	4/6	4/12	0/2	0/6	4/6	4/12	0/2	2/6	3/6	5/12
Total	0/8	8/24	19/24	27/48	0/8	3/24	22/24	25/48	0/8	12/24	10/24	22/48
Mean Ct-value ± SD	–	39.8 ± 2.6	36.4 ± 3.1	–	–	39.5 ± 1.0	31.0 ± 2.4	–	–	33.0 ± 1.1	33.0 ± 1.1	–
Percentage of specificity	100.0	–	–	–	100.0	–	–	–	100.0	–	–	–
Percentage of sensitivity	–	33.3	79.2	56.3	–	12.5	91.7	52.1	–	50.0	41.7	45.8
(B) Recovery of virus bioaccumulated in mussels (no. of positive RT-PCR reactions/total no.)												
1	2/2	5/6	6/6	11/12	2/2	6/6	6/6	12/12	0/2	6/6	6/6	12/12
2	2/2	5/6	6/6	11/12	2/2	6/6	6/6	12/12	1/2	4/6	6/6	10/12
3	0/2	4/6	2/6	6/12	2/2	2/6	4/6	6/12	0/2	2/6	2/6	4/12
4	0/2	6/6	6/6	12/12	2/2	6/6	6/6	12/12	0/2	1/6	6/6	7/12
Total	4/8	20/24	20/24	40/48	8/8	20/24	22/24	42/48	1/8	13/24	20/24	33/48
Mean Ct-value ± SD	39.6 ± 2.1	37.5 ± 1.6	32.0 ± 0.8	–	35.7 ± 2.5	34.0 ± 1.6	31.9 ± 2.9	–	39.6	37.8 ± 1.2	31.8 ± 2.1	–
Percentage of sensitivity	–	83.3	83.3	83.3	–	83.3	91.7	87.5	–	54.2	83.3	68.8

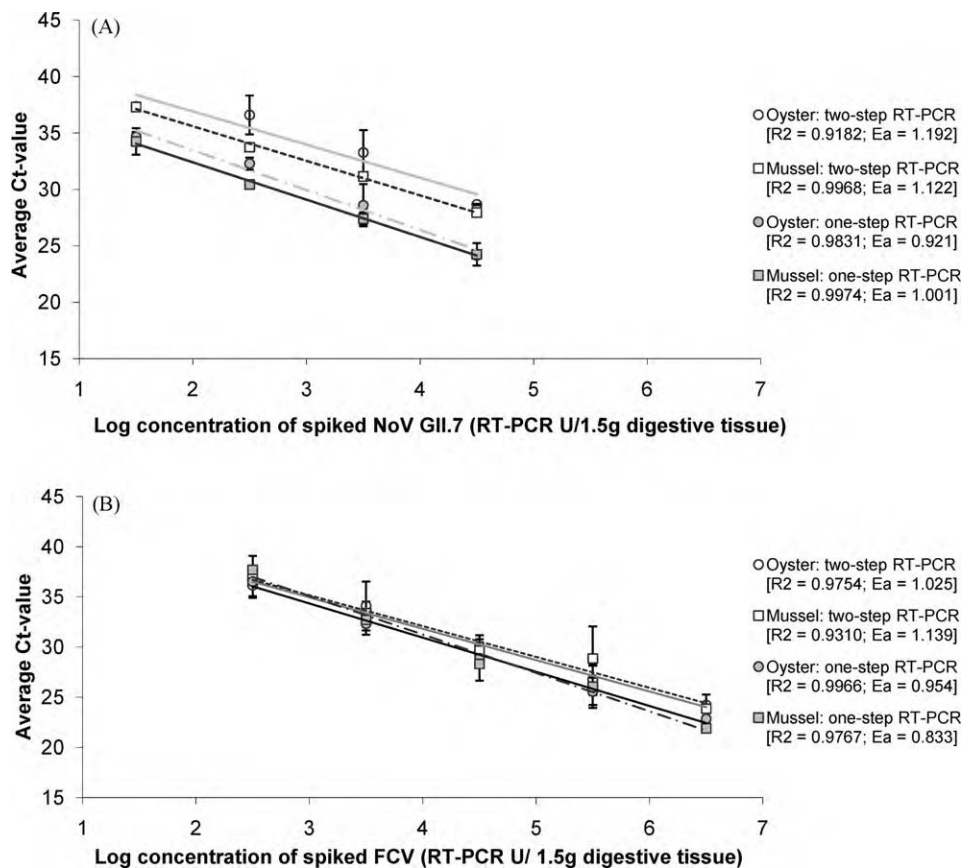

Fig. 2. Detection of NoV genotype II.7 (A) and FCV (B) spiked in the digestive tissue of oysters and blue mussels using a two-step TaqMan RT-PCR and one-step TaqMan RT-PCR.

semi-automatic kit based on a modification of the Boom method (Boom et al., 1990). This approach using paramagnetic silica beads simplifies the otherwise laborious extraction procedures, which normally involve several steps, manual handling and in-house made buffers that may result in variations between batches. Moreover, minimum handling of hazardous chemicals such as the phenol-chloroform is achieved when using method E.

In this study, we found that the performance of the NucliSENS extraction kit is equally good or slightly better than the Boom extraction for detection of NoV in shellfish samples, which is in agreement with the studies of Comelli et al. (2008) and Le Guyader et al. (2009).

The superiority of method E to recover NoV GII.7 and FCV from both oysters and mussels found here is also supported by the study of Comelli et al. (2008), in which they compared the ability of three methods, based on (I) PEG6000 precipitation, (II) ultracentrifugation (method C in the present study), and (III) proteinase K treatment (similar to method E) to recover NoV GI.3b and NoV GII.4 spiked and bioaccumulated in mussels (*M. edulis*). Comelli et al. (2008) found that only the proteinase K based method was able to detect both NoV GI.3b and GII.4, although the ultracentrifugation method showed a slightly better recovery of NoV GII.4 in mussels unlike our observations for NoV GII.7. This difference in results indicates that the success of a particular sample treatment method could be influenced by the strain of NoV.

In the present study the sensitivity and robustness of a two-step TaqMan RT-PCR were compared with a simpler one-step TaqMan RT-PCR on RNA extracts (method E) from mussels and oysters. For the detection of FCV and NoV GII.7, the one-step assay was found to give slightly better results in terms of both linearity and sensitivity. The better sensitivity, however, may be a natural effect of more

cDNA being analysed in the one-step than in the two-step assay. Because the one-step assay has fewer handling steps, it is faster, simpler to implement, easier to harmonize between laboratories and less prone to cross-contamination, thus, it was chosen as the detection method for the collaborative study.

In order for a method to be used as a standard for recovery of virus in shellfish, it must be sensitive and robust. In addition, the method must demonstrate that it can be used for recovery of viruses in naturally contaminated samples where viruses may be bound physiologically within the tissue. This binding may not be simulated correctly in spiked samples as used in the comparative study, although this has a routine approach for comparison of virus recovery methods. Thus, to evaluate the reliability and reproducibility of method E, a small collaboration on shellfish bioaccumulated with NoV GI, NoV GII and HAV was established with four participating laboratories.

On oysters bioaccumulated with high levels of NoV GI.3b and NoV GII.4, the method was found to be fairly robust, with a specificity of 100% and a sensitivity above 79%. However, for low levels of NoV GII.4, a poor percentage of sensitivity was found, which could indicate that the amount of NoV GII.4 used for the bioaccumulation was below the detection limit of the assay and/or that the NoV GII.4 accumulates slower than NoV GI.3b for which slightly better recovery was observed. Another feasible explanation for the observed difference in recovery of low levels of NoV GI.3b and NoV GII.4 is that the strains bind to different receptors in the shellfish. Histo-blood group antigens on human cells function as viral receptors for both NoV GI and GII, but binding patterns of NoV GI and GII with different carbohydrate structures of the histo-blood group family have been reported (Hutson et al., 2004; Shirato et al., 2008). Since similar histo-blood group antigens have been demonstrated to be

present in oysters and mussels (Le Guyader et al., 2006a; Tian et al., 2007), it is likely that specific binding patterns of the NoV GI and GII strains may influence their ability to bioaccumulate in shellfish. This also correlates with data reporting a relative high prevalence of NoV GI strains in shellfish and in shellfish-related outbreaks, despite the fact that most NoV strains circulating in humans are GII (de Roda Husman et al., 2007; Jothikumar et al., 2005; Kageyama et al., 2004; Le Guyader et al., 2003, 2006b, 2009).

Laboratories 1 and 2 seemed to have a higher recovery for some virus strains and matrices compared with the two other laboratories. In particular, laboratory 3 had considerable lower recovery of all viruses from mussels as well as NoV GI.3b from oysters, which is likely due to lack of experience in working with viruses in food matrices. In mussels, the calculated percentages of sensitivity were in some cases influenced by problems in the sample treatment of the two mussel samples, processed by laboratory 3, as seen by a lack of recovery of the process control, vMC₀. An exclusion of these particular samples from the data set would increase sensitivity from 83.3 to 100% for both NoV GI.3b and HAV bioaccumulated in high level as well as for NoV GII.4 in low level. However, since the objective was to evaluate the method performance across several laboratories, all data have been included in order to reflect the reality, where problems such as these might occur.

In the collaborative study, one laboratory found one out of two of the mussel samples not subjected to bioaccumulation to be positive for HAV, although with a higher Ct-value than was obtained for the bioaccumulated samples. This resulted in a specificity of 87.5%. Despite that none of the negative controls gave positive HAV results, a likely explanation could be cross-contamination during the viral extraction or PCR detection.

Several laboratories detected NoV GI and GII in the mussel samples which had not been bioaccumulated. This was probably due to natural contamination during cultivation, as these non-bioaccumulated mussels were handled separately from the bioaccumulated samples and because cross-contamination in all four laboratories is unlikely. Indeed, natural contamination of virus in shellfish is an established problem and detection of NoV and HAV in commercial samples has been reported in several other studies (Boxman et al., 2006; Le Guyader et al., 1996, 2009; Lowther et al., 2008; Myrmel et al., 2004; Simmons et al., 2007). In order to exclude a potential crossover of NoV GI.3b and NoV GII.4 in the laboratories, sequencing of the real-time RT-PCR products from the mussel samples, which had not been bioaccumulated, was attempted but unsuccessful. This presumed natural NoV GI and GII contamination of the mussel samples prevented calculation of the percentage of specificity for mussels. However, in the comparative study, a specificity of 100% for NoV GII.7 was obtained, indicating that the method is specific under normal circumstances. The natural contamination may also be reflected in the calculated percentage of sensitivity. The amount of virus present in the mussel samples will thus be higher than in the oyster samples making a direct comparison on the method performance in these matrixes impossible.

Mengovirus strain vMC₀ was included as a process control from the first step of the sample treatment in order to compare the extraction efficiency between samples and laboratories. As a member of the Picornaviridae family, vMC₀ share structural characteristics with HAV (Costafreda et al., 2006). In addition, vMC₀ is non-pathogenic to humans, can be grown in cell culture, has not been reported to be naturally present in shellfish and shows similar behavior during bioaccumulation in shellfish as NoV GI and NoV GII (Costafreda et al., 2006; Le Guyader et al., 2009). For these reasons vMC₀ was proposed as a process extraction control for HAV (Costafreda et al., 2006) and later for NoV (Le Guyader et al., 2009) in viral analysis of shellfish. The present collaborative study shows the strength of vMC₀ as a process control, in the sense that a poor recovery of vMC₀ was found to correlate with a poor recovery of

NoV GI.3b, NoV GII.4 and HAV in specific samples. To a lesser extent, the study demonstrates that vMC₀ can be employed to compare recovery efficiencies in both oysters and mussels between laboratories, where vMC₀ recovery efficiencies of $1.8\% \pm 2.4$ and $1.2\% \pm 1.8$ were found in oysters and mussels, respectively. The variability of the vMC₀ recoveries was observed both within and between laboratories and indicates that vMC₀ is not completely stable under the conditions used, which also could explain the somewhat low recovery efficiencies. Spiked vMC₀ has previously been shown by Comelli et al. (2008) to be 15–17.5-fold less stable than spiked NoV GI and GII under conditions identical to those used in our study. However, it has recently been demonstrated that both recovery efficiency and variability of spiked vMC₀ could be improved by lowering the secondary incubation temperature of proteinase K from 65 to 60 °C, at which vMC₀ is more stable, without decreasing NoV recovery (James Lowther, CEFAS, personal communication). Although the recovery of spiked vMC₀ may not reflect the recovery of naturally contaminated enteric viruses, it is valuable as a measurement of recovery efficiency. Combined with a scientific defined level of acceptance, information on the quality of the sample treatment can guide the user to accept or repeat the treatment of the specific sample. Currently, a 1% recovery of vMC₀ has been suggested, pragmatically based on extraction efficiencies of 500 shellfish samples, when using method E with secondary proteinase K incubation at 60 °C (James Lowther, CEFAS, personal communication). Analysis of enteric viruses in complex matrices like food and water should not be considered valid without a process control monitoring the entire sample treatment.

The study shows that method E was easily implemented in the four participating laboratories and used to robustly recover NoV GI, NoV GII and HAV bioaccumulated in shellfish.

The method is a good candidate as a future standard for routine analysis of oysters and mussels for the most important viruses known to contaminate shellfish. In fact, method E evaluated in this study is very similar to the draft method developed by the European standardization group (CEN/TC 275/WG6/TAG4), which is currently a prime candidate for a new standard. To our knowledge, this is the first collaborative evaluation of the method on bioaccumulated shellfish. Although a more elaborate validation is necessary for standardization purposes (Anon, 2009), the present study may support the work of the European standardization group (CEN/TC 275/WG6/TAG4) for virus detection in food and water.

Acknowledgments

This study was supported by the Nordic Council of Ministers grant NNM 681048-05320. We thank Linda Alice Bergström for excellent technical assistance.

References

- Anon, 2009. NordVal Protocol for the Validation of Alternative Microbiological Methods.
- Anon, 2010. Regulation (EC) No 854/2004 of the European Parliament and of the Council of 29 April 2004 laying down specific rules for the organisation of official controls on products of animal origin intended for human consumption. Off. J. Eur. Commun. L226, 83–127.
- Atmar, R.L., Neill, F.H., Romalde, J.L., Guyader, F.L., Woodley, C.M., Metcalf, T.G., Estes M.K., 1995. Detection of Norwalk virus and hepatitis A virus in shellfish tissues with the PCR. Appl. Environ. Microbiol. 61, 3014–3018.
- Beuret, C., Baumgartner, A., Schlupe, J., 2003. Virus-contaminated oysters: a three-month monitoring of oysters imported to Switzerland. Appl. Environ. Microbiol. 69, 2292–2297.
- Bidawid, S., Malik, N., Adegunrin, O., Sattar, S.A., Farber, J.M., 2003. A feline kidney cell line-based plaque assay for feline calicivirus, a surrogate for Norwalk virus. J. Virol. Methods 107, 163–167.
- Boom, R., Sol, C.J.A., Salimans, M.M.M., Jansen, C.L., Wertheim van Dillen, P.M.E., Noordaa, J.V.D., 1990. Rapid and simple method for purification of nucleic acids [from cell-rich sources, as exemplified for pathogenic Gram-negative bacteria,

- with suggestions for the wider application of this method in clinical microbiology]. *J. Clin. Microbiol.* 28, 495–503.
- Boxman, I.L., Tilburg, J.J., te Loeke, N.A., Vennema, H., Jonker, K., de Boer, E., Koopmans, M., 2006. Detection of noroviruses in shellfish in the Netherlands. *Int. J. Food Microbiol.* 108, 391–396.
- Comelli, H.L., Rimstad, E., Larsen, S., Myrnel, M., 2008. Detection of norovirus genotype I.3b and II.4 in bioaccumulated blue mussels using different virus recovery methods. *Int. J. Food Microbiol.* 127, 53–59.
- Costafreda, M.L., Bosch, A., Rosa, M., Bosch, A., 2006. Development, evaluation, and standardization of a real-time TaqMan reverse transcription-PCR assay for quantification of hepatitis A virus in clinical and shellfish samples. *Appl. Environ. Microbiol.* 72, 3846–3855.
- da Silva, A., Le Saux, J.-C., Parnaudeau, S., Pommepuy, M., Elimelech, M., Le Guyader, F.S., 2007. Evaluation of removal of noroviruses during wastewater treatment, using real-time reverse transcription-PCR: different behaviors of genogroup I and II. *Appl. Environ. Microbiol.* 73, 7891–7897.
- de Medici, D., Croci, L., Di Pasquale, S., Fiore, A., Toti, L., 2001. Detecting the presence of infectious hepatitis A virus in molluscs positive to RT-nested-PCR. *Lett. Appl. Microbiol.* 33, 362–366.
- de Roda Husman, A.M., Lodder-Verschoor, F., van den Berg, H.H., Le Guyader, F.S., van Pelt, H., van der Poel, W.H., Rutjes, S.A., 2007. Rapid virus detection procedure for molecular tracing of shellfish associated with disease outbreaks. *J. Food Prot.* 70, 967–974.
- Hutson, A.M., Atmar, R.L., Estes, M.K., 2004. Norovirus disease: changing epidemiology and host susceptibility factors. *Trends Microbiol.* 12, 279–287.
- Jothikumar, N., Lowther, J.A., Henshilwood, K., Lees, D.N., Hill, V.R., Vinje, J., 2005. Rapid and sensitive detection of noroviruses by using TaqMan-based one-step reverse transcription-PCR assays and application to naturally contaminated shellfish samples. *Appl. Environ. Microbiol.* 71, 1870–1875.
- Kageyama, T., Kojima, S., Shinohara, M., Uchida, K., Fukushi, S., Hoshino, F.B., Takeda, N., Katayama, K., 2003. Broadly reactive and highly sensitive assay for Norwalk-like viruses based on real-time quantitative reverse transcription-PCR. *J. Clin. Microbiol.* 41, 1548–1557.
- Kageyama, T., Kojima, S., Shinohara, M., Uchida, K., Fukushi, S., Hoshino, F.B., Kojima, S., Takai, R., Oka, T., Takeda, N., Katayama, K., 2004. Coexistence of multiple genotypes, including newly identified genotypes, in outbreaks of gastroenteritis due to norovirus in Japan. *J. Clin. Microbiol.* 42, 2988–2995.
- Kojima, S., Kageyama, T., Fukushi, S., Hoshino, F.B., Shinohara, M., Uchida, K., Natori, K., Takeda, N., Katayama, K., 2002. Genogroup-specific PCR primers for detection of Norwalk-like viruses. *J. Virol. Methods* 100, 107–114.
- Koopmans, M., Duizer, E., 2004. Foodborne viruses: an emerging problem. *Int. J. Food Microbiol.* 90, 23–41.
- Le Guyader, F., Neill, F.H., Estes, M.K., Monroe, S.S., Ando, T., Atmar, R.L., 1996. Detection and analysis of a small round-structured virus strain in oysters implicated in an outbreak of acute gastroenteritis. *Appl. Environ. Microbiol.* 62, 4268–4272.
- Le Guyader, F., Haugarreau, L., Miossec, L., Dubois, E., Pommepuy, M., 2000. Three-year study to assess human enteric viruses in shellfish. *Appl. Environ. Microbiol.* 66, 3241–3248.
- Le Guyader, F.S., Neill, F.H., Dubois, E., Bon, F., Loisy, F., Kohli, E., Pommepuy, M., Atmar, R.L., 2003. A semiquantitative approach to estimate Norwalk-like virus contamination of oysters implicated in an outbreak. *Int. J. Food Microbiol.* 87, 107–112.
- Le Guyader, F., Parnaudeau, S., Schaeffer, J., Bosch, A., Loisy, F., Pommepuy, M., Atmar, R.L., 2009. Detection and quantification of noroviruses in shellfish. *Appl. Environ. Microbiol.* 75, 618–624.
- Le Guyader, F.S., Loisy, F., Atmar, R.L., Hutson, A.M., Estes, M.K., Ruvoen-Clouet, N., Pommepuy, M., Le Pendu, J., 2006a. Norwalk virus-specific binding to oyster digestive tissues. *Emerg. Infect. Dis.* 12, 931–936.
- Le Guyader, F.S., Bon, F., Demedici, D., Parnaudeau, S., Bertone, A., Crudeli, S., Doyle, A., Zidane, M., Suffredini, E., Kohli, E., Maddalo, F., Monini, M., Gallay, A., Pommepuy, M., Pothier, P., Ruggeri, F.M., 2006b. Detection of multiple noroviruses associated with an international gastroenteritis outbreak linked to oyster consumption. *J. Clin. Microbiol.* 44, 3878–3882.
- Lees, D., Henshilwood, K., Dore, W.J., 1994. Development of a method for detection of enteroviruses in shellfish by PCR with poliovirus as a model. *Appl. Environ. Microbiol.* 60, 2999–3005.
- Lees, D., 2000. Viruses and bivalve shellfish. *Int. J. Food Microbiol.* 59, 81–116.
- Loisy, F., Atmar, R.L., Guillon, P., Le Cann, P., Pommepuy, M., Le Guyader, F.S., 2005. Real-time RT-PCR for norovirus screening in shellfish. *J. Virol. Methods* 123, 1–7.
- Lowther, J.A., Henshilwood, K., Lees, D.N., 2008. Determination of norovirus contamination in oysters from two commercial harvesting areas over an extended period, using semiquantitative real-time reverse transcription PCR. *J. Food Prot.* 71, 1427–1433.
- Martin, L.R., Duke, G.M., Osorio, J.E., Hall, D.J., Palmenberg, A.C., 1996. Mutational analysis of the mengovirus poly(C) tract and surrounding heteropolymeric sequences. *J. Virol.* 70, 2027–2031.
- Mullendore, J.L., Sobsey, M.D., Shieh, Y.C., 2001. Improved method for the recovery of hepatitis A virus from oysters. *J. Virol. Methods* 94, 25–35.
- Myrnel, M., Rimstad, E., Berg, E.M.M., Grinde, B., 2004. Detection of enteric viruses in shellfish from the Norwegian coast. *Appl. Environ. Microbiol.* 70, 2678–2684.
- Nishida, T., Kimura, H., Saitoh, M., Kozawa, K., Kato, M., Shinohara, M., Fukuda, S., Munemura, T., Mikami, T., Kawamoto, A., Akiyama, M., Kato, Y., Nishio, O., Nishi, K., 2003. Detection, quantitation, and phylogenetic analysis of noroviruses in Japanese oysters. *Appl. Environ. Microbiol.* 69, 5782–5786.
- Reed, L.J., Muench, H., 1938. A simple method of estimating fifty percent endpoint. *Am. J. Hyg.* 27, 493–497.
- Schultz, A.C., Saadbye, P., Hoorfar, J., Norrung, B., 2007. Comparison of methods for detection of norovirus in oysters. *Int. J. Food Microbiol.* 114, 352–356.
- Shieh, Y.S.C., Monroe, S.S., Fankhauser, R.L., Langlois, G.W., Burkhardt III, W., Baric, R.S., 2000. Detection of Norwalk-like virus in shellfish implicated in illness. *J. Infect. Dis.* 181, S360–S366.
- Shirato, H., Ogawa, S., Ito, H., Sato, T., Kameyama, A., Narimatsu, H., Xiaofan, Z., Miyamura, T., Wakita, T., Ishii, K., Takeda, N., 2008. Noroviruses distinguish between type 1 and type 2 histo-blood group antigens for binding. *J. Virol.* 82, 10756–10767.
- Simmons, G., Garbutt, C., Hewitt, J., Greening, G., 2007. A New Zealand outbreak of norovirus gastroenteritis linked to the consumption of imported raw Korean oysters. *N. Z. Med. J.* 120, U2773.
- Svraka, S., Duizer, E., Vennema, H., de Bruin, E., van der Veer, B., Dorresteyn, B., Koopmans, M., 2007. Etiological role of viruses in outbreaks of acute gastroenteritis in The Netherlands from 1994 through 2005. *J. Clin. Microbiol.* 45, 1389–1394.
- Tian, P., Engelbrektsen, A.L., Jiang, X., Zhong, W., Mandrell, R.E., 2007. Norovirus recognizes histo-blood group antigens on gastrointestinal cells of clams, mussels, and oysters: a possible mechanism of bioaccumulation. *J. Food Prot.* 70, 2140–2147.
- Venuti, A., Di Russo, C., Del Grosso, N., Patti, A.M., Ruggeri, F., De Stasio, P.R., Martiniello, M.G., Pagnotti, P., Degener, A.M., Et, A.L., 1985. Isolation and molecular cloning of a fast-growing strain of human hepatitis A virus from its double-stranded replicative form. *J. Virol.* 56, 579–588.

Chapter 7

Manuscript II

Inter-laboratory evaluation of a rapid method for recovery of norovirus and adenovirus from various types of Nordic drinking water

Katrine Uhrbrand, Mette Myrmel, Leena Maunula, Elisabeth Hallin, Katarina Brus Sjölander, Sveinn Magnússon, Christine Borgen Jochumsen, Jeffrey Hoorfar and Laurids Siig Christensen.

In preparation for submission

Inter-laboratory evaluation of a rapid method for recovery of norovirus and adenovirus from various types of Nordic drinking water

Katrine Uhrbrand¹, Mette Myrmet², Leena Maunula³, Elisabeth Hallin⁴, Katarina Brus Sjölander⁴, Sveinn Magnússon⁵, Christine Borgen Jochumsen⁶, Jeffrey Hoorfar¹ and Laurids Siig Christensen¹.

¹ Division of Microbiology and Risk Assessment, National Food Institute, Technical University of Denmark, DTU, Søborg, Denmark

²Department of Food Safety and Infection Biology, Norwegian School of Veterinary Science, Oslo, Norway

³Department of Food Hygiene and Environmental Health, University of Helsinki, Helsinki, Finland

⁴Center for Microbiological Preparedness, Swedish Institute for Infectious Disease Control, Solna, Sweden

⁵Department of Food Safety and Environment, Matis ohf, Reykjavik, Island

⁶ Department of Informatics and Mathematical Modeling, Technical University of Denmark, DTU, Lyngby, Denmark

Abstract

Enteric viruses, in particular noroviruses (NoVs), have emerged as a major cause of waterborne outbreaks. It is therefore essential to have efficient viral recovery methods available for both screening and outbreak investigations. Recently, a promising method, based on membrane filtration followed by direct lysis of viruses adsorbed to the membrane, was described for efficient recovery of NoV from bottled water. This study evaluated the methods ability to recover ten-fold serial dilutions of NoV genogroup I and II (GI and GII) and adenovirus (AdV) spiked in 20 different types of Nordic drinking water (tap water). A mean 50% limit of detection (LOD₅₀) of 13±9, 9±12 and 12±11 RT-PCR U/1.5 L drinking water was found for NoV GI, NoV GII and AdV, respectively. This was similar to the detection limit previously determined for NoVs using the method on bottled water. The mean percentage of recovery from all drinking water types was 43±29, 45±24 and 15±12 for NoV GI, NoV GII and AdV, respectively, with recovery of AdV being significantly lower than for NoV GI and GII. The recovery of NoV GI and GII was found to be markedly improved using the present method compared to previously described methods also employing positively charged membranes to recover NoVs from drinking water, suggesting that the method could be suitable for routine analysis. However, virus and water type were found to affect the recovery.

1. Introduction

Human enteric viruses cause gastrointestinal disease in humans and are estimated to cause up to 90% of gastroenteritis cases worldwide (Haramoto et al., 2005). These viruses are excreted in high concentration in faeces of infected patients and are transmitted mainly by the faecal-oral route via direct person-to person spread or through contaminated food and water (Haramoto et al., 2005; Koopmans and Duizer, 2004).

In the past decade it has become increasingly evident that enteric viruses, in particular norovirus (NoV), play an important role in waterborne disease. Numerous outbreaks of norovirus-associated gastroenteritis originating from contaminated drinking water have been reported in industrialised countries (Borchardt et al., 2011; Carrique-Mas et al., 2003; Lodder and Roda Husman, 2005; Maunula et al., 2009; Maunula et al., 2005; Nygard et al., 2004; Nygard et al., 2003; Räsänen et al., 2010; ter Waarbeek et al., 2010). Furthermore, in many of the waterborne outbreaks, where the infective agent could not be established, enteric viruses, such as NoVs, are likely to be the culprit (Borchardt et al., 2004).

Viral contamination originates from sewage or other faecal waste sources entering the resource water for the drinking water production. In many countries surface water from rivers and lakes are used as raw water sources. However, sewage containing high concentrations of enteric viruses may be discharged into the surface water during heavy rainfall (Lodder et al., 2010), and can cause outbreaks if viruses survive the subsequent water treatment. Groundwater, on the other hand, is generally considered to be a safe drinking water source, which requires little or no treatment, due to a natural filtration mechanism by soil during gravitational movement (Kvitsand and Fiksdal, 2010; Quanrud et al., 2003; WHO, 2006). However, improper management such as poor sewage disposal or breaks in sewage pipes/septic systems in the vicinity of wells can lead to faecal contamination of ground water and have resulted in several groundwater-related viral outbreaks (Borchardt et al., 2011; Nygard et al., 2004; Nygard et al., 2003; Park et al., 2010). While established methods for analysing bacteria and parasites in drinking water have been available for a long time, standardised methods for recovery of viruses are not at hand. It is an increasing concern at waterworks that viral pathogens cannot be analysed rapidly and reliably, thereby reducing the possibility to evaluate control strategies.

In the Nordic countries drinking water consists of treated surface water or untreated or minimally treated groundwater of various qualities depending on the country and region. There is a lack of knowledge of how different types and qualities of water affect the recovery of virus.

Components present in some types/qualities could possibly result in poor viral recovery due to co-concentration and extraction of inhibitors to the following RT-PCR reaction. Moreover some component could perhaps bind viruses preventing them from being properly concentrated and extracted. Knowledge of the influence of different water types and qualities on the viral detection limit is desirable for screening and outbreak purposes.

Recently, a simple and rapid recovery method for efficient concentration of hepatitis A virus (HAV) from 1.5 L of bottle water was developed by Perelle et al. (2009). The method had higher recovery of HAV and feline calicivirus (FCV), a NoV surrogate, compared with four other methods including the method suggested as standard by the European Committee on Normalisation (CEN) expert working group (CEN/TC 275/WG6/TAG4). Moreover, the method was evaluated on one type of bottle water spiked with HAV, FCV, NoV GI and GII in a collaborative study and considered to be robust enough for routine virus analysis (Schultz et al., 2011). However, it is unknown how the method works on drinking water of different types, which is imperative information if the methods should be employed for routine screening or outbreak investigations of drinking water in general. Hence, the objective of this study was to evaluate the methods ability to recover NoV GI and GII as well as human adenovirus (AdV) from Nordic drinking water of various types.

2. Materials and methods

2.1. Viruses and cells

Stool samples of NoV GI.14, NoV GII.4 variant 2006b and AdV serotype 41 were quantified by endpoint real-time RT-PCR to contain 1×10^9 RT-PCR U/mL, 1×10^7 RT-PCR U/mL and 1×10^{10} PCR U/mL, respectively. Recombinant Mengovirus, MC₀, (ATCC VR-2310, kindly provided by Prof Albert Bosch, University of Barcelona, Spain) was used as a process control. The MC₀ stock was propagated in HeLA cells (ATCC CCL-2) (Martin et al., 1996) and titrated by TCID₅₀ assay (1×10^8 TCID₅₀/mL) (Reed and Muench, 1938).

Stool samples and MC₀ were distributed on ice to the participating laboratories and used for spiking experiments.

Ten-fold serial dilutions of viruses were made in phosphate-buffered saline (PBS; 145mM NaCl, 7.7mM Na₂HPO₄, and 2.3mM NaH₂PO₄, pH 7.4) at the recipient laboratories prior to spiking experiments.

2.2 Collaborative study

Drinking water (tap water) of various types were collected in all five Nordic countries and used for spiking experiments. The chemical/organic composition of the 20 selected drinking water types are listed in Table 1. Spiking, virus concentration, nucleic acid extraction and production of random cDNA were carried out in the respective national laboratory. The cDNA and the extracted AdV DNA were subsequently sent on ice to DTU-FOOD, Denmark, where quantification was performed.

2.3 Spiking of drinking water

A volume of 1.5 L of each water sample was spiked on two separate occasions with 100µl of 10-fold serial dilutions of viruses to a final quantity ranging from 10 to 10^4 RT-PCR U of NoV GI and GII, and 10^2 to 10^5 PCR U of AdV41. In addition 10^5 TCID₅₀ of MC₀ was added to the water samples as a process control. A sample of non-spiked water was used as negative process control in each experiment.

2.4 Method for virus concentration method and nucleic acid extraction

Viruses were concentrated and nucleic acid extracted as described by Schultz et al. (2011). Briefly, viruses were concentrated by membrane filtration under vacuum using a Sartorius

filter (47mm diameter positively charged polyamide, pore size 0.45µm, Sartorius Steadim, Taastrup, Denmark). Filters were subsequently incubated for 15 min at room temperature in a 60mm diameter Petri dish containing 3 ml of NucliSENS lysis buffer (BioMerieux, Herlev, Denmark). The total lysate was used for nucleic acid purification using NucliSENS miniMAG system (BioMerieux, Herlev, Denmark) according to the manufactures' instructions, and eluted in 100µl of NucliSENS elution buffer.

2.5. Amplification and detection of viral genomes

Detection of NoV GI, NoV GII and MC₀ was performed using a two-step reverse transcription (RT) - real-time polymerase reaction (qPCR). Production of cDNA was performed on 12.5µl RNA in a total reaction volume of 50µl containing 500 U Superscript III RT enzyme (Invitrogen), 250 ng random primers (Invitrogen), 0.5 mM of each dNTP (Promega), 1 × First-strand Buffer (Invitrogen), 5 mM DTT (Invitrogen), and 100 U Rnase inhibitor (Applied Biosystems). RT was carried out at 25°C for 5 min, 50°C for 60 min and 70°C for 15 min. qPCR were performed in duplicates on 5µL cDNA in a total reaction volume of 25µL using TaqMan universal PCR mastermix (Applied Biosystems). Previously described primers and probes for NoV GI (da Silva et al., 2007; Svraha et al., 2007), NoV GII (Kageyama et al., 2003; Loisy et al., 2005) and MC₀ (Costafreda et al., 2006) and reaction conditions (Uhrbrand et al., 2010) were used.

AdV41 was detected by qPCR on 2.5 µL of the extracted DNA as described by Jothikumar et al. (2005) using a QuantiTech Probe PCR kit (QIAGEN, Copenhagen, Denmark) with primers JTVXF/JTVXR and probe JTVXP, labeled with FAM in the 3' end and a black hole quencher in the 5' end.

The qPCRs were performed on a 96-well plate format of ABI StepOne (Applied Biosystems, Nærum, Denmark). In all assays fluorescence was measured at the end of each cycle and baseline was calculated between cycle 3 and 15. The cycle threshold (C_t) set at 0.07. Quantification was performed using standard curves from AdV41 DNA, MC₀ RNA and *in vitro* RNA transcripts of NoV GI.3b and NoV GII.4.

2.6. Data analysis

2.6.1. Determination of a 50% limit of detection

In accordance with NordVal (Anon, 2009), a 50% limit of detection value (LOD₅₀) was calculated on the qualitative data in order to evaluate the performance of the method on

different water types. Calculations of LOD_{50} were based on the Spearman-Kärber method and express the viral concentration (RT-PCR U/1.5L drinking water) that corresponds to a 50% probability of a positive result when using the recovery method on the particular water type. Calculation of LOD_{50} requires a spiking level giving a 100% response. In cases where none of the spiking levels gave such a response, a spiking level 10 times the uppermost level giving a partial response was assumed to give a 100% response. For the non-spiked negative process controls, a concentration of 0.004 RT-PCR U/1.5 L drinking water was allocated.

2.6.2. Statistical analysis of quantitative results

The recovery was calculated from the number of viral genomes detected in the samples as a percentage to the number of viral genomes spiked in the sample and was determined for each water type, virus and spiking level.

Statistical analysis, including calculation of average recoveries, was based on all MC_0 results. For NoV GI, NoV GII and AdV41 the results from the two highest spiking levels were used as these were within the quantitative range. The analyses were carried out by mixed models evaluating the relation between the dependent variable given by the recovery proportion and the following dependent variables: Water Type and Laboratory. In addition, Replicate, Water Type \times Replicate and Sample \times Water Type, were included as random variables. All analyses were performed using R.

3. Results

3.1 Qualitative results and LOD_{50}

The qualitative results from virus detection in water type A-T are presented in Table 2. The mean LOD_{50} 's for the 20 different Nordic water types (A-T) were calculated to be 13.0 ± 8.7 and 9.0 ± 12.3 RT-PCR U/1.5 L for NoV GI and GII, respectively and 11.6 ± 10.7 PCR U/1.5 L for AdV.

For NoV GI, water type R, originating from Iceland, resulted in the best recovery with a LOD_{50} of 1.8 RT-PCR U/1.5 L, while the poorest recovery of 32.5 RT-PCR U/1.5 was found for the Swedish water type N followed by water type G and H from Finland, M from Sweden and T from Norway all with a LOD_{50} of 23.4 RT-PCR U/1.5. For NoV GII, recovery was found to be least sensitive for water type T from Norway followed by water type J from Finland and Q from Sweden with LOD_{50} 's of 44.8, 32.3 and 23.4 RT-PCR/1.5 L, respectively. Finally, water types F and J both from Finland were found to give the least sensitive for recovery of AdV with a LOD_{50} of 32.5 PCR U/1.5 L.

3.2 Quantitative results

The calculated mean recoveries (percentage) for NoV GI, NoV GII, AdV41 and MC_0 from the various water types can be found in Table 3. The average recoveries for all water samples (A-T) were 42.6 ± 28.9 (NoV GI), 44.5 ± 24.3 (NoV GII), 15.1 ± 12.4 (AdV41) and $45.6 \pm 27.6\%$ (MC_0), with the recovery of AdV41 being significantly lower than for NoV GI, NoV GII and MC_0 .

For the recovery of NoV GI, NoV GII and AdV41, only water type was found to have a significant effect, while water type and laboratory significantly affected the recovery of MC_0 . The MC_0 recoveries were significantly higher for the Swedish (K-O) than for the Danish, Icelandic and Norwegian water samples. Moreover, the Finish water samples (F-J) had significantly higher MC_0 recoveries than the Danish and Norwegian samples.

The water types that gave significantly different recoveries by pair wise comparison are listed in Table 4. A similar pattern in the recovery across all virus types was only observed for water type P and T for which significantly higher and lower recoveries were generally observed. For the remaining water types recoveries seem to some extent to be dependent on the virus strain.

4. Discussion

In order to reduce the risk of gastrointestinal illness caused by consumption of virally contaminated drinking water there is a need for a standardised recovery method which can be used for routine screening as well as outbreak investigations. Although numerous procedures for recovery of virus in drinking water have been described no method has been evaluated on a broad variety of drinking water types/qualities and sufficiently validated for standardisation. Hence, a method for rapid and sensitive recovery of virus from bottled water was tested for the recovery NoV GI, GII and AdV41 from 20 different Nordic drinking water types.

Based on the qualitative data, the method recovered viruses from all the tested water types. The mean detection limit of 13.0 ± 8.7 RT-PCR U/1.5 L for NoV GI was similar to the 9.0 ± 0 RT-PCR U/1.5 L found by Schultz et al. (2011) using the same method on bottle water. For NoV GII the mean LOD_{50} of 9.0 ± 12.3 RT-PCR U/1.5 L in the present study was similar to the detection limit of NoV GI, but lower than that of 286 ± 184 found for NoV GII on bottled water (Schultz et al., 2011). The fact that a relatively minor variation between LOD_{50} 's was obtained for the different water types and that these LOD_{50} 's furthermore were comparable with, or in case of NoV GII better than, that found on bottle water indicate that the method is relatively robust and is suitable for recovery of NoVs from a broad range of drinking water. In addition, we demonstrated that the method can also be used for recovery of DNA viruses such as AdV with a LOD_{50} similar to that observed for NoV GI and GII.

A variety of methods for recovery of enteric virus from water has been developed. Most of these are adsorption-elution techniques consisting of a primary concentrate viruses from larger volumes of water using an adsorption matrix, followed by virus elution from the matrix and a secondary concentration step prior nucleic acid extraction. The recovery of NoV from drinking water has previously been studied for a few of these methods. Recoveries of less than 5% have been found using positively charged membranes (Albinana-Gimenez et al., 2009; Gilgen et al., 1997; Karim et al., 2009). Methods based on adsorption to glass wool have on average recovered 3 and 30% of NoV GII (Albinana-Gimenez et al., 2009) (Lambertini et al., 2008). A NoV recovery efficiency of 50%, and thus comparable to that found in the present study, was achieved with negatively charged filters coated with $AlCl_3$ for primary concentration (Haramoto et al., 2009), while NoV adsorption to a negatively charged membrane following preconditioning with $MgCl_2$ gave an average recovery of 3% (Victoria et al., 2009) and 80% (Haramoto et al., 2009). The high recovery in the latter study by Haramoto et al. (2009) might, however, be overestimated as an

average recovery of 167% from bottled water was found in the same study. In addition to the above mentioned adsorption-elution based methods, ultrafiltration using a commercial cartridge has been employed but resulted in less than 1% recovery of NoV GII (Albinana-Gimenez et al., 2009). Overall, the recoveries in the present study appear to be higher, or at least comparable, to that previously found using other methods. Moreover, the method used in the present study has the additional advantage of being very rapid as no elution and secondary concentration step is required.

In the present study, the recovery of AdV41 was significantly lower than the recovery of NoV GI, NoV GII and MC₀. This difference could be attributed to AdV41 not being properly adsorbed to the positively charged membrane. Adsorption occurs through electrostatic and hydrophobic interactions and is dependent of the isoelectric point (pI) of the virus. At pH above their pI viruses have an overall negative charged and will bind to the positively charged membrane. While the NoV major structural protein have a pI range from 5.2 to 5.7 and 5.5 to 6.9 for NoV GI and GII, respectively (Goodridge et al., 2004), the AdV41 major structural proteins of hexon, penton base, long fibre (head) and short fibre (head), is predicted to be 5.5, 5.6, 7.5 and 9.31, respectively (Favier et al., 2004). At the pH of the drinking water AdV41 will therefore contain domains that does not favour adsorption due to their positively charge. Another plausible explanation is the presence of non-encapsidated AdV DNA. Whereas free DNA will be detected in the DNA extracts of the AdV stock used to determine the spiking concentration, free DNA spiked into the water samples may not be retained by the filter leading to an underestimation of the recovery efficiency.

The water type significantly affected the recovery of all the virus types. This is probably due to differences in the composition of the drinking water as virus adsorption kinetics are known to be affected by ionic strength, pH and the presence of organic components. Increasing ionic strength gives increasing adsorption of NoV-virus-like particles (NoV-VLPs) (da Silva et al., 2011). Moreover, da Silva et al. (2011) demonstrated that the presence of the divalent cations Ca²⁺ and Mg²⁺ dramatically enhance adsorption of NoV-VLPs compared with monovalent ions, such as Na⁺, while bicarbonate ions decreased adsorption. Similar effects of divalent cations on adsorption of poliovirus, rotavirus and MS2 have also been reported (Gutierrez et al., 2010; Lance and Gerba, 1984; Pham et al., 2009) and have been attributed to cation binding between viruses and surfaces. The exact effect of specific anions and cations on virus adsorption has, however, been found to vary between virus strains, presumably due to differential responses of the unique arrangement of exposed amino acids residues on the capsid surface of the viruses (da Silva et al., 2011; Gutierrez et

al., 2010). In addition to adsorption kinetics, the presence of RT-PCR inhibitors could also be a contributing factor to the variation in recovery between water types. As no inhibitory tests were conducted in this study the possibility of co-extraction of inhibitor cannot be excluded. Hence, in future inhibitory interference of viral recovery from the drinking water should be examined.

In addition to water type, laboratory was found to have a significant effect on the recovery of MC₀ but not for NoV GI, NoV GII and AdV. As the water types tested in the different national laboratories were not identical, the laboratory effect might be a consequence of confounding by water type. Hence, the laboratory effect may stem from national difference in the quality of drinking water, difference in laboratory performance, or a combination hereof. The laboratory effect was only observed for MC₀ and could be due to the fact that one concentration of MC₀ was spiked as a process control into the water samples, while four spiking levels were used for NoV GI, NoV GII and AdV and statistical analysis performed on the two highest levels only. A laboratory effect could be masked for these viruses by too few observations and uncertainties introduced by using more than one spiking level.

Variation in the recovery was generally seen within repetitions from one water type. Although unwanted, such variability is not unusual and has been observed in most studies that have quantitatively recovered NoV from drinking water (Albinana-Gimenez et al., 2009; Haramoto et al., 2009; Karim et al., 2009; Lambertini et al., 2008; Victoria et al., 2009). However, due to the basic level of variation between repetitions and interactions between effects of virus and water type, it is difficult to identify specific water quality parameters that could have an influence on the general virus recovery in the present study. In order to obtain more knowledge regarding the influence of the composition of the water on the recovery more controlled empirical experiments, testing both single and cumulative effects of various chemical and organic components present in water, should be conducted on a selection of viruses.

Overall, the method was easily implemented in the participating laboratories and found to be applicable on all the different Nordic drinking water types tested. The method was simple and sensitive, and good virus recoveries were generally achieved, suggesting that the method could be suitable for routine analysis. Virus recovery was, however, found to be influenced by virus strain and water type. Recovery efficiencies should therefore, ideally, be checked for each water type and virus strain of interest.

Acknowledgments

The work was supported by grant NKJ-130 from the Nordic Joint Committee for Agricultural Research.

References

- Anon., 2009. NordVal protocol for the validation of alternative microbiological methods.
- Albinana-Gimenez,N., Clemente-Casares,P., Calgua,B., Huguet,J.M., Courtois,S., Girones,R., 2009. Comparison of methods for concentrating human adenoviruses, polyomavirus JC and noroviruses in source waters and drinking water using quantitative PCR. *J. Virol. Methods.* 158, 104-109.
- Borchardt,M.A., Haas,N.L., Hunt,R.J., 2004. Vulnerability of drinking-water wells in La Crosse, Wisconsin, to enteric-virus contamination from surface water contributions. *Appl. Environ. Microbiol.* 70, 5937-5946.
- Borchardt,M.A., Bradbury,K.R., Alexander,E.C., Alexander,S.C., Kolberg,R.J., Archer,J.R., Braatz,L.A., Forest,B.M., Green,J.A., Spencer,S.K., 2011. Norovirus Outbreak Caused by a New Septic System in a Dolomite Aquifer. *Ground Water.* 49, 85-97.
- Carrique-Mas,J., Andersson,Y., Petersen,B., Hedlund,K.O., Sjogren,N., Giesecke,J., 2003. A Norwalk-like virus waterborne community outbreak in a Swedish village during peak holiday season. *Epidemiol. Infect.* 131, 737-744.
- Costafreda,M.I., Bosch,A., Rosa,M., 2006. Development, evaluation, and standardization of a real-time TaqMan reverse transcription-PCR assay for quantification of hepatitis A virus in clinical and shellfish samples. *Appl. Environ. Microbiol.* 72, 3846-3855.
- da Silva,A.K., Kavanagh,O.V., Estes,M.K., Elimelech,M., 2011. Adsorption and Aggregation Properties of Norovirus GI and GII Virus-like Particles Demonstrate Differing Responses to Solution Chemistry. *Environ. Sci. Technol.* 45, 520-526.
- da Silva,A.K., Le Saux,J.C., Parnaudeau,S., Pommepuy,M., Elimelech,M., Le Guyader,F., 2007. Evaluation of removal of noroviruses during wastewater treatment, using real-time reverse transcription-PCR: Different behaviors of genogroups I and II. *Appl. Environ. Microbiol.* 73, 7891-7897.
- Favier,A.L., Burmeister,W.P., Chroboczek,J., 2004. Unique physicochemical properties of human enteric Ad41 responsible for its survival and replication in the gastrointestinal tract. *Virology.* 322, 93-104.
- Gilgen,M., Germann,D., Lüthy,J., Hübner,P., 1997. Three-step isolation method for sensitive detection of enterovirus, rotavirus, hepatitis A virus, and small round structured viruses in water samples. *Int. J. Food Microbiol.* 37, 189-199.
- Goodridge,L., Griffiths,M., Goodridge,C., Pawliszyn,J., Wu,J., 2004. Isoelectric point determination of norovirus virus-like particles by capillary isoelectric focusing with whole column imaging detection. *Anal. Chem.* 76, 48-52.
- Gutierrez,L., Mylon,S.E., Nash,B., Nguyen,T.H., 2010. Deposition and Aggregation Kinetics of Rotavirus in Divalent Cation Solutions. *Environmental Science & Technology.* 44, 4552-4557.

- Haramoto,E., Katayama,H., Oguma,K., Ohgaki,S., 2005. Application of cation-coated filter method to detection of noroviruses, enteroviruses, adenoviruses, and torque teno viruses in the Tamagawa River in Japan. *Appl. Environ. Microbiol.* 71, 2403-2411.
- Haramoto,E., Katayama,H., Utagawa,E., Ohgaki,S., 2009. Recovery of human norovirus from water by virus concentration methods. *J. Virol. Methods.* 160, 206-209.
- Jothikumar,N., Cromeans,T.L., Hill,V.R., Lu,X., Sobsey,M.D., Erdman,D.D., 2005. Quantitative real-time PCR assays for detection of human adenoviruses and identification of serotypes 40 and 41. *Appl. Environ. Microbiol.* 71, 3131-3136.
- Kageyama,T., Kojima,S., Shinohara,M., Uchida,K., Fukushi,S., Hoshino,F.B., Takeda,N., Katayama,K., 2003. Broadly Reactive and Highly Sensitive Assay for Norwalk-Like Viruses Based on Real-Time Quantitative Reverse Transcription-PCR. *J. Clin. Microbiol.* 41, 1548-1557.
- Karim,M.R., Rhodes,E.R., Brinkman,N., Fout,G.S., Wymer,L., 2009. New electropositive filter for concentrating enteroviruses and noroviruses from large volumes of water. *Appl. Environ. Microbiol.* 75, 2393-2399.
- Koopmans,M., Duizer,E., 2004. Foodborne viruses: An emerging problem. *Int. J. Food Microbiol.* 90, 23-41.
- Kvitsand,H.M.L., Fiksdal,L., 2010. Waterborne disease in Norway: emphasizing outbreaks in groundwater systems. *Water Sci. Technol.* 61, 563-571.
- Lambertini,E., Loge,F.J., Spencer,S.K., Bertz,P.D., Kieke,B.A., Borchardt,M.A., 2008. Concentration of enteroviruses, adenoviruses, and noroviruses from drinking water by use of glass wool filters. *Appl. Environ. Microbiol.* 74, 2990-2996.
- Lance,J.C., Gerba,C.P., 1984. Effect of ionic composition of suspending solution on virus adsorption by a soil column. *Appl. Environ. Microbiol.* 47, 484-488.
- Lodder,W.J., Roda Husman,A.M., 2005. Presence of noroviruses and other enteric viruses in sewage and surface waters in the Netherlands. *Appl. Environ. Microbiol.* 71, 1453-1461.
- Lodder,W.J., van den Berg,H.H.J.L., Rutjes,S.A., Husman,A.M., 2010. Presence of Enteric Viruses in Source Waters for Drinking Water Production in the Netherlands. *Appl. Environ. Microbiol.* 76, 5965-5971.
- Loisy,F., Atmar,R.L., Guillon,P., Le Cann,P., Pommepuy,M., Le Guyader,F.S., 2005. Real-time RT-PCR for norovirus screening in shellfish. *J. Virol. Methods.* 123, 1-7.
- Martin,L.R., Duke,G.M., Osorio,J.E., Hall,D.J., Palmenberg,A.C., 1996. Mutational analysis of the mengovirus poly(C) tract and surrounding heteropolymeric sequences. *J. Virol.* 70, 2027-2031.

- Maunula,L., Klemola,P., Kauppinen,A., Soderberg,K., Nguyen,T., Pitkanen,T., Kaijalainen,S., Simonen,M.L., Miettinen,I.T., Lappalainen,M., Laine,J., Vuento,R., Kuusi,M., Roivainen,M., 2009. Enteric Viruses in a Large Waterborne Outbreak of Acute Gastroenteritis in Finland. *Food Environ Virol.* 1, 31-36.
- Maunula,L., Miettinen,I.T., von Bonsdorff,C.H., 2005. Norovirus outbreaks from drinking water. *Emerg. Infect. Dis.* 11, 1716-1721.
- Nygard,K., Vold,L., Halvorsen,E., Bringeland,E., Rottingen,J.A., Aavitsland,P., 2004. Waterborne outbreak of gastroenteritis in a religious summer camp in Norway, 2002. *Epidemiol. Infect.* 132, 223-229.
- Nygard,K., Torven,M., Ancker,C., Knauth,S.B., Hedlund,K.O., Giesecke,J., Andersson,Y., Svensson,L., 2003. Emerging genotype (GGIIb) of norovirus in drinking water, Sweden. *Emerg. Infect. Dis.* 9, 1548-1552.
- Park,S.H., Kim,E.J., Yun,T.H., Lee,J.H., Kim,C.K., Seo,Y.H., Oh,S.A., Choi,S.S., Cho,S.J., Kim,M.S., Han,G.Y., Kim,M.Y., Jeong,H.S., Cheon,D.S., Kim,H.S., 2010. Human Enteric Viruses in Groundwater. *Food Environ Virol.* 2, 69-73.
- Perelle,S., Cavellini,L., Burger,C., Blaise-Boisseau,S., Hennechart-Collette,C., Merle,G., Fach,P., 2009. Use of a robotic RNA purification protocol based on the NucliSens® easyMAG; for real-time RT-PCR detection of hepatitis A virus in bottled water. *J. Virol. Methods.* 157, 80-83.
- Pham,M., Mintz,E.A., Nguyen,T.H., 2009. Deposition kinetics of bacteriophage MS2 to natural organic matter: Role of divalent cations. *J. Colloid Interface Sci.* 338, 1-9.
- Quanrud,D.M., Carroll,S.M., Gerba,C.P., Arnold,R.G., 2003. Virus removal during simulated soil-aquifer treatment. *Water Res.* 37, 753-762.
- Räsänen,S., Lappalainen,M., Kaikkonen,S., Hämäläinen,M., Salminen,M., Vesikari,T., 2010. Mixed viral infections causing acute gastroenteritis in children in a waterborne outbreak. *Epidemiol. Infect.* 138, 1227-1234.
- Reed,L.J., Muench,H., 1938. A simple method of estimating fifty per cent endpoint. *Am. J. Hyg.* 27, 493-497.
- Schultz,A.C., Perelle,S., Di Pasquale,S., Kovac,K., De Medici,D., Fach,P., Sommer,H.M.I., Hoorfar,J., 2011. Collaborative validation of a rapid method for efficient virus concentration in bottled water. *Int. J. Food Microbiol.* 145.
- Svraka,S., Duizer,E., Vennema,H., de Bruin,E., van der Veer,B., Dorresteyn,B., Koopmans,M., 2007. Etiological role of viruses in outbreaks of acute gastroenteritis in the Netherlands from 1994 through 2005. *J. Clin. Microbiol.* 45, 1389-1394.
- ter Waarbeek,H.t.L.G., Dukers-Muijers,N.H.T.M., Vennema,H., Hoebe,C.J.P.A., 2010. Waterborne gastroenteritis outbreak at a scouting camp caused by two norovirus genogroups: GI and GII. *J. Clin. Virol.* 47, 268-272.

Uhrbrand,K., Myrmel,M., Maunula,L., Vainio,K., Trebbien,R., Nørrung,B., Schultz,A.C., 2010. Evaluation of a rapid method for recovery of norovirus and hepatitis A virus from oysters and blue mussels. *J. Virol. Methods.* 169, 70-78.

Victoria,M., Guimarães,F., Fumian,T., Ferreira,F., Vieira,C., Leite,J.P., Miagostovich,M., 2009. Evaluation of an adsorption-elution method for detection of astrovirus and norovirus in environmental waters. *J. Virol. Methods.* 156, 73-76.

WHO, 2006. *Protecting Groundwater for Health, Managing the Quality of drinking-water Sources.*

Table 1. Characteristic of the 20 different Nordic water types (A-T) included in the evaluation of the method.

Parameters	Unit	Drinking water type																			
		Denmark					Finland					Sweden					Iceland		Norway		
		A	B	C	D	E	F	G	H	I	J	K	L	M	N	O	P	Q	R	S	T
Water source ^a	-	G	G	G	G	G	S	S	G	G ^b	S	S	S	S	S	S	S	SP	G	S	S
Treatment ^d		Ox	Ox	Ox	Ox	Ox	Ox	CL	Ox	Ox	Ox	CL	CL	CL	CL	CL	CL	UV	RO	SE	MF
		SF	SF	SF	SF	SF	SF	SF	LF	AC	Oz	LF	AC	Oz	AC	UV	UV	CL	UV	MF	UV
				AC					AC	UV	UV	UV	UV	UV	UV	UV	UV				
							CL		CL	CL	CL	CL	CL	CL	CL	CL	CL				
pH	pH	8	8.6	7.2	7.4	7.5	8.5	8	7.8	8	NA	8.5	8.2	7.9	8	8	7.3	9.7	7.3	7.8	7.1
Colour	mg Pt/L	11	2	2	4	3	NA	3	NA	0	<5	6	5	5	<5	10	<5	<5	NA	3	4
Conductivity	mS/m	100	29	136	59	77	16	31	36	11	17	NA	31	11	20	NA	100	82	550	14	NA
Turbidity	FTU	0.17	<0.10	0.22	0.97	0.19	0.08	0.23	NA	0.10	0.12	0.06	0.08	<0.10	<0.05	0.17	0.17	0.26	1.10	<0.10	<0.10
Chlorine, total	mg/L	0	0	0	0	0	0.38	0.46	NA	0.26	0.35	NA	0.30	NA	0.23	0.13	NA	NA	NA	NA	NA
Hardness, total	°dH	9.5	4.6	28.7	18.9	16.7	3.4	6.5	NA	2.6	4.1	NA	6.6	2.8	3.3	NA	0.8	0.9	NA	NA	NA
Coliform 37°C	CFU/100 ml	<1	<1	<1	<1	<1	<1	<1	<1	<1	<1	<1	<1	<1	<1	<1	<1	<1	30	<1	<1
Total CFU, 22°C	CFU/ml	8	<1	1	<1	4	<1	<1	<1	NA	NA	NA	<1	1	<1	3	<1	1	<1	<1	10

NA, not analysed.
^a Source of the drinking water. (G), (S) and (SP) refer to groundwater, surface water and spring water, respectively.
^b Artificially produced groundwater
^c Induced groundwater
^d Treatment employed during production of drinking water. Explanation of abbreviations; (Ox) oxygenation, (SF) sand filtration, (AC) activated carbon, (Oz) ozone, (UV) ultraviolet radiation, (CL) chlorination, (LF) lime filtration, (RO) reverse osmosis, (SE) sedimentation, (MF) membrane filtration.

Table 2. Qualitative virus results (endpoint detection) for various types (A-T) of Nordic drinking water and limit of detection (LOD_{50}). Volumes of 1.5 L of drinking water were spiked with 10-fold serial dilutions of NoV GI, NoV GII and AdvV41. Viral RNA/DNA was recovered on two distinct occasions using filtration followed by extraction from the membrane. Detection of viruses was subsequently carried out in duplicates, giving four determinations for each water type, virus and spiking level.

Viral load ^a	No. of positive detections on water types from each Nordic country																				ALL Total A-T
	DK					FI					SE					IS					
	A	B	C	D	E	F	G	H	I	J	K	L	M	N	O	P	Q	R	S ^d	T	
Nov GI																					
1.0E+03	4	4	4	4	4	4	4	4	4	4	4	4	4	4	4	4	4	4	4	4	
1.0E+02	4	4	4	4	4	4	4	4	4	4	4	4	4	4	4	4	4	4	4	4	
1.0E+01	2	2	4	2	4	3	4	4	4	4	3	4	4	3	3	3	3	4	2	4	
1.0E+00	1	0	1	1	1	1	0	0	3	3	3	1	0	0	1	2	1	4	0	0	
LOD_{50}^b	11.9	16.5	6.2	11.9	6.2	15.6	23.4	23.4	2.6	2.6	3.6	11.3	23.4	32.4	15.6	7.6	15.6	1.8	5.8	23.4	
Mean LOD_{50}^c	10.2±5.0					13.5±10.4					17.3±11.1					8.3±7.0		14.6±12.4		13.0±8.7	
Nov GII																					
1.0E+03	NA	NA	4	4	4	4	4	4	4	4	4	4	4	4	4	4	4	4	4	4	
1.0E+02	NA	NA	4	4	4	4	4	4	4	4	4	4	4	4	4	4	4	4	4	4	
1.0E+01	NA	NA	4	4	3	4	4	4	4	3	4	4	4	4	4	4	4	4	2	2	
1.0E+00	NA	NA	3	3	3	2	2	2	4	0	4	4	4	2	4	4	0	1	0	0	
LOD_{50}^b	-	-	2.6	2.6	3.6	5.5	5.5	5.5	1.3	32.3	1.3	1.3	1.3	5.5	1.3	1.3	23.4	11.3	11.2	44.8	
Mean LOD_{50}^c	2.9±0.6					9.8±12.6					2.1±1.9					12.0±11.1		19.8±23.8		9.0±12.3	
AdvV41																					
1.0E+03	4	4	4	4	4	4	4	4	4	4	4	4	4	4	4	4	4	4	4	4	
1.0E+02	4	4	4	4	4	4	4	4	4	4	4	4	4	4	4	4	4	4	4	4	
1.0E+01	4	2	4	4	4	4	3	4	4	3	4	4	4	4	4	4	3	4	0	4	
1.0E+00	1	1	2	3	0	2	0	0	4	0	3	2	4	3	1	3	1	4	0	0	
LOD_{50}^b	11.3	21.6	5.5	2.6	23.4	5.5	32.4	23.4	1.3	32.4	2.6	5.5	1.3	2.6	11.3	2.6	15.6	1.3	6.4	23.4	
Mean LOD_{50}^c	12.9±9.4					19.0±14.8					4.7±4.0					6.5±7.9		14.9±12.0		11.6±10.7	

NA, not analysed.

^a Viral loads expressed in RT-PCR U for NoV GI and GII and PCR U for Adv.

^b LOD_{50} detection levels at which 50% of replicates are positive.

^c Mean LOD_{50} values and standard deviations calculated for each virus by national water types and as a total of all water types.

^d The viral load used was ¼ of that stated in the table. The calculated LOD_{50} was adjusted accordingly.

Table 3. Mean recovery of NoV GI, NoV GII, AdV41 and MC₀ from 1.5 L of various types of Nordic drinking water tested on two distinct occasions and detected in duplicates. The recovery was calculated from the quantitative results for MC₀ (process control) and the two highest spiking levels of NoV GI, NoV GII and AdV.

Water type	Mean recovery (%) ^a			
	NoV GI	NoV GII	AdV	MC ₀
<i>DK</i>				
A	16.7±11.9	NA	16.2±11.4	37.6±20.6
B	13.5±12.0	NA	4.2±3.0	20.6±17.2
C	26.7±22.2	54.7±25.1	11.0±6.8	67.7±25.2
D	19.9±14.3	39.7±15.0	8.3±1.6	29.2±6.4
E	27.2±18.6	54.5±13.9	29.1±32.4	25.2±15.4
<i>FI</i>				
F	41.5±22.3	34.5±14.1	26.3±16.2	71.3±18.3
G	57.9±24.0	28.6±6.8	16.1±14.0	25.1±16.4
H	29.7±3.0	41.8±18.6	10.0±4.5	74.0±15.5
I	84.5±33.0	30.1±14.3	29.0±4.8	80.0±23.4
J	24.5±9.3	40.0±39.6	15.1±7.0	27.2±17.3
<i>SE</i>				
K	46.0±21.3	67.3±8.2	12.0±3.7	82.9±22.8
L	82.6±25.6	79.5±39.3	11.8±4.7	81.1±27.5
M	56.1±9.8	79.3±32.7	10.8±3.9	60.1±17.9
N	34.3±15.7	33.3±10.7	10.5±5.5	45.6±30.4
O	28.0±6.2	58.1±6.2	8.8±3.3	71.3±28.7
<i>IS</i>				
P	76.0±38.6	56.9±18.6	31.0±9.3	51.7±8.6
Q	21.6±8.9	38.9±4.4	1.5±1.4	34.3±4.8
R	45.4±21.2	38.5±11.6	23.6±11.9	31.0±8.5
<i>NO</i>				
S	69.9±17.9	22.5±5.3	30.0±17.0	26.8±4.3
T	3.3±2.9	13.7±6.3	0.3±0.3	12.8±7.1
<i>ALL</i>				
Total A-T	42.6±28.9	44.5±24.3	15.1±12.4	45.6±27.6

NA, not analysed.

^a Mean recovery (in %) and standard deviation calculated for each virus and water type.

Table 4. Water types found to give significantly different recovery efficiencies by pair wise comparison. Water types found to have significantly higher recovery, comparatively, are shown in bold.

Water type	NoV GI	NOV GII	AdV	Mengo
<i>DK</i>				
A	I, L	NA	-	F, H, I, K, L, O
B	I, L	NA	F, I, P, S	C, F, H, I, K, L, M, O
C	-	T	-	B, D, E, G, J, Q, R, S, T
D	I	-	I, P, S	C, F, H, I, K, L, M, O
E	I, L	-	Q, T	C, F, H, I, K, L, M, O
<i>FI</i>				
F	-	L, M	B, Q, T	A, B, D, E, G, J, Q, R, S, T
G	T	L, M	-	C, F, H, I, K, L, M, O
H	I, L	-	P	A, B, D, E, F, G, J, Q, R, S, T
I	A, B, C, D, E, H, J, O, Q, I, T	M	B, D, Q, T	A, B, D, E, G, J, N, Q, R, S, T
J	I, L	-	-	C, F, H, I, K, L, M, O
<i>SE</i>				
K	-	S, T	-	A, B, D, E, G, J, N, Q, R, S, T
L	J, O, Q, T	F, G, I, N, R, S, T	-	A, B, D, E, G, J, Q, R, S, T
M	T	F, G, I, N, S, T	-	B, D, E, G, J, S, T
N	-	L, M	P	I, K, T
O	I, L	T	P	A, B, D, E, G, J, Q, R, S, T
<i>IS</i>				
P	Q, T	T	B, D, H, N, O, Q, T	T
Q	I, L, P	-	E, F, I, P, R, S	C, F, H, I, K, L, O
R	-	L	Q, P, T	C, F, H, I, K, L, O
<i>SE</i>				
S	T	K, L, M	B, D, Q, T	C, F, H, I, K, L, M, O
T	G, I, L, M, P, Q, S	C, K, L, M, O; P	E, F, I, P, R, S	C, F, H, I, K, L, M, N, O, P

NA, not analysed.

Chapter 8

Manuscript III

Feasibility of using molecularly imprinted polymers for norovirus recognition and capture

Katrine Uhrbrand, Wei Sun, Börje Sellergren and Laurids Siig Christensen

Manuscript based on preliminary results

Feasibility of using molecularly imprinted polymers for norovirus recognition and capture

Katrine Uhrbrand¹, Wei Sun², Börje Sellergren² and Laurids Siig Christensen¹

¹ Division of Microbiology and Risk Assessment, National Food Institute, Technical University of Denmark, DTU, Mørkhøj Bygade 19, DK-2860 Søborg, Denmark

² Institute of Environmental Research, Dortmund University of Technology, Otto-Hahn Str. 6, D-44221 Dortmund, Germany

Abstract

The use of virus imprinted polymers (VIPs) is a potential concentration strategy for selective binding of noroviruses (NoVs) from drinking water. In the present study the feasibility of using VIPs for selective recognition of noroviruses was investigated. Three VIPs targeted for murine norovirus (MNV), NoV genogroup I and II, respectively, were synthesized and experiments to determine binding of the target viruses and a non-target adenovirus (AdV) to the VIPs and to non-imprinted polymers (NIPs) were conducted. In general, a high degree of unspecific binding was observed with no significant difference in the binding of target viruses to the VIPs and NIPs, despite the fact that a higher percentage of binding was found for all VIPs compared with the NIPs. Binding to the MNV-imprinted polymer was found to be significantly lower ($P < 0.03$) for the non-target AdV than MNV indicating a certain degree of selectivity due to geometrical factors. However, no significant difference was found for binding of AdV and target NoVs to the other VIPs. Overall, a poor selective recognition of the VIPs was observed in this study. Therefore the VIPs in their current form do not seem to be a feasible approach for concentration of NoVs from drinking water, albeit with further development and optimization VIPs could still have a potential.

1. Introduction

Viruses, in particular noroviruses (NoVs), are an important cause of waterborne disease and are a matter of serious concern for public health (Butot et al. 2007). Numerous outbreaks of NoV-associated gastroenteritis originating from contaminated drinking or recreational water have for instance been reported in industrialised countries (Lodder & Roda Husman 2005). While established methods for analyzing bacteria and parasites have been available for a long time, both concentration and detection methods for viruses are usually not at hand. It is an increasing concern at waterworks that the viral load of the distributed water cannot be analyzed quickly and reliably.

Molecularly imprinting is a potential concentration strategy for selectively induced binding of a target virus such as NoV. Molecularly imprinted polymers (MIPs) are highly crosslinked polymers formed in the presence of a template molecule (Zhang et al. 2010). Synthesis of MIPs can be achieved through a non-covalent approach in which addition of the template molecule to a pre-polymer mixture containing functional monomers will cause spatial arrangement of the monomers around the template due to non-covalent interactions, such as hydrophobic interactions, hydrogen bonds, Van der Waals forces and electrostatic interactions (Verheyen et al. 2011). The spatial arrangement can then be fixed by polymerization of the monomers and an excess of crosslinker (Verheyen et al. 2011; Zhang et al. 2010). Subsequent disruption of the non-covalent interactions between template molecule and polymer matrix by a washing step will result in removal of the template from the crosslinked matrix (Bolisay & Kofinas 2010). Thus, creating a three-dimensional polymer matrix containing binding cavities that are chemically and sterically complementary to the template, and therefore able to sensitively rebind the template or a template analog (Bolisay & Kofinas 2010; Verheyen et al. 2011). Hence, the MIPs are functional in the sense that they exhibit a memory for the template (or related structures) in a similar manner to the way antibodies bind antigens. However, in contrast to the biological recognition elements, MIPs are remarkably stable against mechanical stress, high temperatures, intense radiation, and resistant to pH and a wide range of solvents (Greibrokk & Sellergren 2009).

Molecular imprinting can be used for concentration of a target molecule, removal of potential interfering compounds, conversion of a target molecule into a more suitable form for detection, or separation (Turiel & Martín-Esteban 2010). Molecular imprinting has proven to be particularly successful for low molecular weight compounds (Verheyen et al. 2011). Imprinting of larger, more complex molecules such as proteins, DNA, whole cells and viruses have also been

studied but is more challenging. Virus recognition using molecular imprinting has been attempted in a few studies (Bolisay et al. 2007; Bolisay & Kofinas 2010; Hayden et al. 2006). Bolisay et al. (2006) investigated the use of virus imprinted polymers (VIPs) for recognition of Tobacco mosaic virus (TMV) and found TMV-imprinted hydrogels to result in increased and selective binding of TMV. In addition, virus surface imprinting combined with mass-sensitive transducers have been developed by Hayden et al. (2006) for sensor based detection of TMV, human rhinovirus and parapox ovis virus.

The objective of this study was to explore the feasibility of using our previously reported surface imprinting approach by Nematollahzadeh et al. (2011) to generate VIPs displaying selective recognition of NoV. Such receptors could subsequently be used for concentration of noroviruses from drinking water. For the production of the VIPs NoV-virus like particles (VLPs) and the human NoV surrogate, murine norovirus (NMV), were used as target molecules. To evaluate the use of VIPs for selective recognition of NoVs a comparison of binding of both the target noroviruses and a non-targeted adenovirus (AdV) to the VIPs and non-imprinted polymers (NIPs) were conducted. AdV was selected as it is non-enveloped with an icosahedral shape, like NoV, but has a diameter of 70-90 nm (Hierholzer 1992) compared with 27-40 nm (Huffman et al. 2003) for NoV and should therefore not fit into the geometrical cavities present in the NoV-imprinted polymers.

2. Methods & Materials

2.1 Virus strains

MNV strain 1 (kindly provided by Dr. Virgin, Washington University School of Medicine, USA) and recombinant VLPs of a NoV genogroup (G)I, Norwalk strain (rNV VLPs), and of a NoV GII, Houston strain (rHOV VLPs), (kindly provided by Prof. Bosch, University of Barcelona, Spain) were used as templates for production of VIPs.

MNV was propagated in RAW264.7 cells (ATCC TIB-71) as previously described (Wobus et al. 2004). After propagation, MNV-1 was harvested and frozen at -70°C in Low-endo media consisting of 0.01M HEPES buffer (Invitrogen), 1x penicillin-streptomycin (Invitrogen), 1 nM sodium pyovate (Invitrogen), 10% Low endotoxin fetal bovine serum (Hyclone) and Dulbecco's Modified Eagles Medium (DMEM) (Invitrogen). Prior to polymer synthesis, MNV was separated from the proteins present in the Low-endo media by ultracentrifugation at 20319 RPM for 30 min at 4°C in a Beckman Coulter 45Ti rotor and resuspended in 1.5 ml of phosphate buffer (PB, 50 mM, pH 6).

The rNV VLPs and rHOV VLPs were synthesized using recombinant baculovirus and purified by ultracentrifugation through a 30% sucrose cushion followed by isopycnic gradient centrifugation as described previously (Hutson et al. 2003).

Using a DC protein assay (Bio-Rad, Denmark) with bovine gamma globulin as a standard the protein concentration of the purified MNV and VLPs stocks used for imprinting was determined to be 0.24 mg/ml (MNV), 6.3 mg/ml (rNV VLPs) and 2.0 mg/ml (rHOV VLPs) corresponding to a particle concentration of 2.10×10^{13} particles/ml, 3.6×10^{14} particles/ml and 1.16×10^{14} , respectively.

Suspensions of a MNV stock and three stool samples positive for NoV GI.8, GII.4 2006b and AdV serotype 40/41, respectively, were used to test the binding efficiency and selectivity of produced polymers. Suspensions were made in sterile milliQ water just prior to experiments.

2.2 Extraction of Viral RNA/DNA from samples

Nucleic acids was extracted using the NucliSENS miniMAG system (BioMerieux, Herlev, Denmark) according to the manufactures' instructions with the following modifications: the entire sample was incubated in 3 ml of NucliSENS lysisbuffer (BioMerieux, Herlev, Denmark) for 15 min at room temperature followed by 10 min incubation after addition of 100 µl of NucliSENS magnetic silica (BioMerieux, Herlev, Denmark).

2.3 Amplification, detection and quantification of viral genomes in samples

Detection of viruses was performed in triplicates on a 96-well plate format of ABI StepOne (Applied Biosystems, Nærum, Denmark).

NoV genogroup GI, GII and MNV RNA were detected by reverse transcription (RT)-real-time polymerase reaction (qPCR) using the RNA UltraSense one-step quantitative RT-PCR system (Invitrogen, Taastrup, Denmark) and previously described primers and probes for NoV GI (Da Silva et al. 2007; Svraka et al. 2007), NoV GII (Kageyama et al. 2003; Loisy et al. 2005) and MNV (Rawsthorne et al. 2009). The RT-qPCR was carried out in a total of 25 µl reaction mixture constituting 5 µl of extracted viral RNA and 20 µl of RT-qPCR reaction mixture containing 1× UltraSense reaction mix, 500 mM forward primer, 900 mM reverse primer, 250 mM Probe, 1× Rox reference dye and 1× UltraSense enzyme mix. Reaction conditions were as previously described (Le Guyader et al. 2009).

AdV serotype 40/41 DNA was detected by qPCR as described by Jothikumar et al. (2005) using a QuantiTech Probe PCR kit (QIAGEN, Copenhagen, Denmark) with primers JTVXF/JTVXR and probe JTVXP.

Quantification was performed using standard curves generated from 10-fold dilution series of NoV GI.3b and NoV GII.4 RNA transcripts (Gentry et al. 2009), extracted MNV RNA or AdV DNA.

2.4 Polymer preparation and characterization

A total of three polymers imprinted with MNV (MNV VIP), rNV VLPs (NoV GI VIP) and rHOV VLPs (NoV GII VIP), respectively, as well as three NIPs (NIP-a, NIP-b and NIP-c) were synthesized.

For viral imprinting 96 µg purified MNV, 89 µg rNV VLPs or 120 µg rHOV VLPs suspended in 400 µl PB (50 mM, pH 6) were added to 100 mg Silica1000 (size 5 µm, pore diameter 1000 Å, pore volume 0.52 ml/g), while 400 µl pure PB (50 mM, pH 6) were added to the non-imprinted controls. Samples were incubated on a shaker (120 rpm) for three hours at 5°C. After incubation the supernatants were filtered and the coverage was monitored with BCA assay at 562 nm and DC assay at 750 nm on a 96-well glass plate. A polymerisation solution were produced by dissolving 70 mg acryl amide (AAM) and 7.7 mg methylene bisacrylamide (MBA) in 100 µl PB (50 mM, pH 7), degassing with nitrogen in an ice bath for 2 minutes, followed by the addition of

1 mg ammonium persulphate (APS) and 1 μ l tetramethylethylenediamine (TMEDA). Filling of the virus immobilised silica pores with polymerisation solution was performed in a glass column. Solvent was removed from the virus-silica packed SPE cartridge by applying N_2 flow from top and vacuum from below for 10 min, and a sample collected for determination of the degree of immobilisation using DC/BCA assays and real-time RT-PCR for quantification of MNV. The upper part of the columns was sealed via silicone rubber. Polymerization solution was injected and pushed into the pores of the silica via nitrogen pressure (1 bar). Trimethylpentane (2 folds of the bed's void volume) was injected to the cartridges to remove inter polymerization solution between silica particles. Columns were kept at 40°C overnight. After completion of the polymerization, the composite was removed from the columns and the samples were measured by thermal gravity analysis (TGA Q50; TA Instrument New Castle, Delaware) and microscopy (DMR; Leica microsystems, Wetzlar, Germany). The composite were placed in SPE columns and the silica was etched in NH_4HF_2 solution (3M) overnight at RT. The etching solution was filtered out and neutralized with concentrated NaOH. The polymers were subsequently washed with 5 \times 1 ml 0.1 M NaOH, followed by 5 \times 1 ml 3 M urea and 1 \times 1 ml 0.5 M NaOH. Finally the polymers were rinsed with sterile milliQ water. All the washing solutions were collected and quantified with DC assay and/or BCA assay.

2.5 Testing of binding capacity and selectivity of the polymers

The binding capacity of the entire amount of synthesized VIPs and NIPs, packed in SPE columns, were tested in parallel on two separate occasions. In addition, selectivity of the polymers was tested on two separate occasions.

Binding capacities were tested by the addition of 3 ml of 3×10^4 PFU MNV to the MNV VIP and NIP-a, 3×10^5 copies NoV GI to NoV GI VIP and NIP-c and 2×10^5 copies NoV GII to NoV GII VIP and NIP-d, while selectivity experiments were carried out by addition of 3 ml AdV suspension containing 2×10^5 PCR U to all VIPs and NIPs. After inoculation, the samples were incubated for 20 min at room temperature.

The virus solution was then slowly filtered through the polymer containing SPE column using a vacuum manifold set at 0.7 bars. The run-through solution was collected, the RNA extracted from the entire sample and q-RT-PCR performed.

Between experiments the polymers were regenerated by washing with 5×1 ml 0.1 M NaOH, followed by 5×1 ml 3 M urea and 1×1 ml 0.5 M NaOH to remove virus still bound to the polymers.

2.6 Polymer flow rates

The flow rates of the synthesis polymers were determined thrice by measuring the time required for 3 ml of milliQ water to pass through the polymers.

2.7 Data analysis

2.7.1 Incorporation of virus template into VIPs

To assess the success of the viral imprinting the percentage of template virus available for incorporation in the VIPs were estimated based on MNV. This was achieved by calculating the number of MNV genomes immobilized to the silica as a percentage to the total number of genomes used for the imprinting.

2.7.2 Calculation of the percentage of virus binding

The binding capacity of the VIPs and NIPs were calculated from the number of genomes retained in the polymer as a percentage to the number of genomes added.

2.7.3 Statistical analysis of results

Analysis of variance was used to determine the statistical significance between the percentages of virus binding to the VIPs and NIPs. Statistical analyses were carried out using a one-way analysis of variance in Microsoft Office Excel (Microsoft, Redmond, WA, USA). Results with *P* values of < 0.05 were considered statistically significant.

3 Results and discussion

The binding capacities of the VIPs and NIPs are shown in Figure 1. The synthesized MNV, NoV GI and NoV GII VIPs were found to bind 62.5 ± 2.3 , 42.9 ± 1.3 and $44.5\pm 4.2\%$ of the added MNV, NoV GI.8 and NoV GII.4, respectively. Unfortunately, a high degree of unspecific virus binding to the NIPs of 55.9 ± 4.8 , 30.3 ± 5.6 and $30.3\pm 7.1\%$ for MNV, NoV GI.8 and NoV GII.4, respectively, was also observed.

A higher percentage of binding was found for all VIPs compared with the NIPs (Table 1). However, the difference in binding capacity of the VIPs and NIPs was not found to be significant. The virus binding to the VIPs may therefore be a result of unspecific binding rather than binding via specific recognition, although more experimental repetitions of the virus binding should be conducted and included in the statistical analysis before reaching such a conclusion. Unspecific binding is, indeed, a well known problem which can be caused by the excess amount of monomer used for the production of the matrix (Zhang et al. 2010). It has been suggested that dimerization (Zhang et al. 2010) or use of urea based monomers could minimize the unspecific binding (Zhang et al. 2011).

Binding of non-target AdV was found to be 50.4 ± 1.9 , 40.2 ± 17.9 and $47.0\pm 5.0\%$ for the MNV, NoV GI and NoV GII VIPs, respectively, while 20.4 ± 10.5 , 24.9 ± 2.9 and $24.0\pm 10.6\%$ bound to the NIPs (Fig. 1). Binding to the MNV VIP was found to be significantly lower ($P<0.03$) for AdV than MNV, which could indicate a certain degree of selectivity due to geometrical factors. However, no significant difference was found for binding of AdV and target viruses, respectively, to the other VIPs. Finally, no significant difference between AdV binding to VIPs and NIPs was found, which was expected as the VIPs do not contain recognition sites specific for the non-target AdV.

A poor selective recognition could of course be a result of overloading i.e. saturation of low abundant binding sites in the polymer. In this study the concentration of viruses added to the polymers was, however, selected to be below the maximal binding sites estimated to be available in the polymers but above the detection limit. The maximal binding sites in the VIPs were estimated to correspond to approximately 99% of the added template based on the percentage of MNV immobilized on the silica and thus available for incorporation in the polymer matrix. However, despite a high percentage of the template seemingly being incorporated into the polymer, the total viral template load used for the polymer synthesis was approximately 10 times lower than that used previously for protein imprints, which could possibly contribute to lower recognition.

Several other factors may contribute to the relative poor selective recognition of the target viruses and high degree of unspecific binding found for the VIPs. Molecular imprinting was an approach initially developed for low molecular weight compounds and expanding the technique to large biomolecules and microorganisms have shown to be extremely challenging. The highly crosslinked gels, which are used for the molecular imprinting, have been selected specifically for low molecular weight compounds in order to ensure preservation of the imprinting cavities after removal of the template. For larger molecules, however, the high crosslink densities can seriously hinder mass transfer of the template, leading to slow template removal and rebinding kinetics or, in worst case, permanent entrapment of the template in the polymer (Verheyen et al. 2011). However, we expected the here used surface imprinting approach would overcome such limitations.

The degree of swelling of the polymer is dependent on the porogenic solvent used during the polymerization of the VIPs and rebinding. The choice of solvent may therefore also influence the recognition and binding characteristics (Kempe & Kempe 2010). The swelling process can affect the shape of the cavities and the distance between functional groups in the polymer and due to this VIPs can lose their specificity when exposed to the wrong conditions. Optimal rebinding generally occurs when the polymer is exposed to the conditions as those used for the polymerization (Turner et al. 2004). In this study, phosphate buffer was used during polymerization, while water was used as rebinding solvent in order to simulate recognition of viruses from drinking water. This difference in solvents used for polymerization and rebinding could possibly contribute to the poor selective binding seen for the VIPs. Moreover, water have been reported to interfere with hydrogen bonds involved in the recognition and cause extensive swelling resulting in cavities too large to specifically bind the target virus (Bolisay & Kofinas 2010; Kempe & Kempe 2010). Such an effect of water on the VIPs is naturally problematic in relation to recognition and concentration of NoVs from drinking water. However, numerous reports demonstrating successful imprinting of proteins in water or buffered media indicates that this is not necessarily hampering the imprinting of large templates (Gai et al. 2010; Manesiotis et al. 2009; Nematollahzadeh et al. 2011). In some cases the addition of ions to the aqueous rebinding solvent have been shown to reduce swelling by associating with the charged functional groups of the polymers matrix and thereby reducing the repulsive forces (Bolisay & Kofinas 2010; Kempe & Kempe 2010). To counteract swelling of the NoV-imprinted polymers in water such strategies should be investigated further.

Another factor likely to have contributed to the poor selective recognition of the target NoVs is that the VIPs are very sensitive to virus aggregation. Aggregation of the individual reagents

(such as polymer and template) during polymer synthesis will result in the three-dimensional polymers containing cavities that are complementary to these aggregates as oppose to the single virus particles. This will lead to nonspecific binding of the target molecule and loss in selectivity (Bolisay et al. 2007). Likewise, the success of the virus recognition using VIPs created to recognize a single NoV virus particle may be hampered if the test sample contains aggregated viruses as the aggregates will not fit into cavities. Aggregation of NoVs has been reported to be affected by solution chemistry such as ionic strength, pH and presence of specific cations and anions (Da Silva et al. 2011). Thus, optimizations of the solvent used in this study for virus suspensions in connection with VIP synthesis and sample preparation should be conducted in the future in order to minimize virus aggregation and hopefully increase the binding capacity of the VIPs. In addition, other strategies for virus disaggregation such as sonication should be investigated.

Insufficient removal of the template molecule from the polymer matrix can hinder rebinding of the target virus to the polymer as no vacant binding cavities will be present (Bolisay et al. 2007). Hence, the washing solvents used to disrupt the non-covalent interactions between the MNV and NoV-VLP template and polymer matrix is essential to the success of the VIPs. Similarly, complete removal of bound target virus between applications is crucial for reuse of the polymers. As measurements of the amount of viral protein removed from the VIPs during the various steps of chemical washing indicated that removal of template viruses from the VIPs after polymerization was successful (data not shown), insufficient template removal is not believed to be a major problem for the VIPs included in this study. Nevertheless, problems with insufficient removal of MNV template were seen for an imprinted polymer not used in the study. Based on the obtained binding results no significant problems with reuse of the polymers could be seen. Although, differences in virus binding to VIPs and NIPs, in most cases, were less pronounced (Table 1) for the second repetition with a mean Δ -binding percentage of 20.5 ± 13.2 and 13.4 ± 8.9 for repetition 1 and 2, respectively, this difference was not significant. The slightly less efficient virus binding properties of the VIPs observed for the second repetition could, however, be a result of the additional washing with NaOH causing some hydrolysis of the amide cross-links in the polymer as problems with increased polymer swelling and partial loss of selectivity and binding due to treatment with NaOH have previously been reported (Jelinkova et al. 1989; Sellergren & Shea 1993). To determine if hydrolysis occurs an infrared transmission spectra of the polymer should be performed.

Despite identical protocol being used for synthesis of the polymers, large differences in the flow rate of 1 ml water were observed for the polymers (Table 2). This would likely have had

an impact on the obtained binding results. The differences in flow rates may either stem from differences in the porosity of the polymer matrix or different yields of the synthesized polymers seeing as the entire amounts of synthesized polymers were used for the binding experiments in this study. Correlating the binding results to the weight of the polymers could adjust for the latter and should therefore be attempted. However, for future application development of more robust and reproducible VIPs is crucial.

Overall, due to these somewhat disappointing results virus imprinting in the current form do not seem to offer a feasible approach for concentration of noroviruses from drinking water. Nevertheless, the results indicate that virus particles have indeed been imprinted and can be reversibly adsorbed to the macroporous gel beads. This is important for further optimization of the imprinting protocol. Furthermore, given that only small amounts of purified template virus could be accessed in this study, numerous parameters remain to be investigated leaving ample room for improvements of the virus recognitive VIPs in the near future.

Acknowledgements

The work was supported by grant NKJ-130 from the Nordic Joint Committee for Agricultural Research.

References

- Bolisay, L. D., Culver, J. N., Kofinas, P., 2006. Molecularly imprinted polymers for tobacco mosaic virus recognition. *Biomaterials*. 27, 4165-4168.
- Bolisay, L. D., Culver, J. N., Kofinas, P., 2007. Optimization of virus imprinting methods to improve selectivity and reduce nonspecific binding. *Biomacromolecules*. 8, 3893-3899.
- Bolisay, L. D., Kofinas, P., 2010. Imprinted polymer hydrogels for the separation of viruses. *Macromol. Sympos.* 291-292, 302-306.
- Butot, S., Putallaz, T., Croquet, C., Lamothe, G., Meyer, R., Joosten, H., Sanchez, G., 2007. Attachment of enteric viruses to bottles. *Appl. Environ. Microbiol.* 73, 5104-5110.
- Da Silva, A. K., Kavanagh, O. V., Estes, M. K., Elimelech, M., ., 2011. Adsorption and aggregation properties of norovirus GI and GII virus-like particles demonstrate differing responses to solution chemistry. *Environ. Sci. Technol.* 45, 520-526.
- Da Silva, A. K., Le Saux, J. C., Parnaudeau, S., Pommepuy, M., Elimelech, M., Le Guyader, F., 2007. Evaluation of removal of noroviruses during wastewater treatment, using real-time reverse transcription-PCR: Different behaviors of genogroups I and II. *Appl. Environ. Microbiol.* 73, 7891-7897.
- Gai, Q., Qu, F., Zhang, Y., 2010. The preparation of BHB-molecularly imprinted gel polymers and its selectivity comparison to BHB and BSA. *Sep. Sci. Technol.* 45, 2394-2399.
- Gentry, J., Vinjé, J., Lipp, E. K., 2009. A rapid and efficient method for quantitation of genogroups I and II norovirus from oysters and application in other complex environmental samples. *J. Virol. Methods*. 156, 59-65.
- Greibrokk, T., Sellergren, B., 2009. Molecular imprinting in Separation Science. *J. Sep. Sci.* 32, 3263-3264.
- Hayden, O., Lieberzeit, P. A., Blaas, D., Dickert, F. L., 2006. Artificial Antibodies for Bioanalyte Detection - Sensing Viruses and Proteins. *Adv. Funct. Mater.* 16, 1269-1278.
- Hierholzer, Jx. C., 1992. Adenoviruses in the immunocompromised host. *Clin. Microbiol. Rev.* 5, 262-274.
- Huffman, D. E., Nelson, K. L., Rose, J. B., 2003. Calicivirus - An emerging contaminant in water: State of the art. *Environmental Engineering Science*. 20, 503-515.
- Hutson, A. M., Atmar, R. L., Marcus, D. M., Estes, M. K., 2003. Norwalk virus-like particle hemagglutination by binding to H histo-blood group antigens. *J. Virol.* 77, 405-415.
- Jelinkova, M., Shataeva, L. K., Tischenko, G. A., Svec, F., 1989. Reactive polymers. 58. Polyampholytes based on macroporous copolymers of glycidyl methacrylate with ethylene glycol dimethacrylate or divinylbenzene. *React. Polym.* 11, 253-260.

- Jothikumar, N., Cromeans, T. L., Hill, V. R., Lu, X., Sobsey, M. D., Erdman, D. D., 2005. Quantitative real-time PCR assays for detection of human adenoviruses and identification of serotypes 40 and 41. *Appl. Environ. Microbiol.* 71, 3131-3136.
- Kageyama, T., Kojima, S., Shinohara, M., Uchida, K., Fukushi, S., Hoshino, F. B., Takeda, N., Katayama, K., 2003. Broadly Reactive and Highly Sensitive Assay for Norwalk-Like Viruses Based on Real-Time Quantitative Reverse Transcription-PCR. *J. Clin. Microbiol.* 41, 1548-1557.
- Kempe, H., Kempe, M., 2010. Influence of salt ions on binding to molecularly imprinted polymers. *Anal. Bioanal. Chem.* 396, 1599-1606.
- Le Guyader, F., Parnaudeau, S., Schaeffer, J., Bosch, A., Loisy, F., Pommepuy, M., Atmar, R. L., 2009. Detection and quantification of noroviruses in shellfish. *Appl. Environ. Microbiol.* 75, 618-624.
- Lodder, W. J., Roda Husman, A. M., 2005. Presence of noroviruses and other enteric viruses in sewage and surface waters in the Netherlands. *Appl. Environ. Microbiol.* 71, 1453-1461.
- Loisy, F., Atmar, R. L., Guillon, P., Le Cann, P., Pommepuy, M., Le Guyader, F. S., 2005. Real-time RT-PCR for norovirus screening in shellfish. *J. Virol. Methods.* 123, 1-7.
- Manesiotis, P., Borrelli, C., Aureliano, C. S. A., Svensson, C., Sellergren, B. +., 2009. Water-compatible imprinted polymers for selective depletion of riboflavine from beverages. *J. Mater. Chem.* 19, 6185-6193.
- Nematollahzadeh, A., Sun, W., Aureliano, C. S. A., Lütkemeyer, D., Stute, J., Abdekhodaie, M. J., Shojaei, A., Sellergren, B., 2011. High Capacity Hierarchically Imprinted Polymer Beads for Protein Recognition and Capture. *Angew. Chem. Int. Ed.* 50, 495-498.
- Rawsthorne, H., Phister, T. G., Jaykus, L. A., 2009. Development of a Fluorescent In Situ Method for Visualization of Enteric Viruses. *Appl. Environ. Microbiol.* 75, 7822-7827.
- Sellergren, B., Shea, K. J., 1993. Influence of polymer morphology on the ability of imprinted network polymers to resolve enantiomers. *J. Chromatogr. A.* 635, 31-49.
- Svraka, S., Duizer, E., Vennema, H., de Bruin, E., van der Veer, B., Dorresteyn, B., Koopmans, M., 2007. Etiological role of viruses in outbreaks of acute gastroenteritis in the Netherlands from 1994 through 2005. *J. Clin. Microbiol.* 45, 1389-1394.
- Turiel, E., Martín-Esteban, A., 2010. Molecularly imprinted polymers for sample preparation: A review. *Anal. Chim. Acta.* 668, 87-99.
- Turner, N. W., Piletska, E. V., Karim, K., Whitcombe, M., Malecha, M., Magan, N., Baggiani, C., Piletsky, S. A., 2004. Effect of the solvent on recognition properties of molecularly imprinted polymer specific for ochratoxin A. *Biosens. Bioelectron.* 20, 1060-1067.
- Verheyen, E., Schillemans, J. P., van Wijk, M., Demeniex, M. A., Hennink, W. E., van Nostrum, C. F., 2011. Challenges for the effective molecular imprinting of proteins. *Biomaterials.* 32, 3008-3020.

- Wobus, C. E., Karst, S. M., Thackray, L. B., Chang, K. O., Sosnovtsev, S. V., Belliot, G., Krug, A., Mackenzie, J. M., Green, K. Y., Virgin, H. W., 2004. Replication of Norovirus in cell culture reveals a tropism for dendritic cells and macrophages. *PLoS Biol.* 2, 2076-2084.
- Zhang, Y., Song, D., Brown, J. C., Shimizu, K. D., 2011. Suppression of background sites in molecularly imprinted polymers via urea-urea monomer aggregation. *Org. Biomol. Chem.* 9, 120-126.
- Zhang, Y., Song, D., Lanni, L. M., Shimizu, K. D., 2010. Importance of Functional Monomer Dimerization in the Molecular Imprinting Process. *Macromolecules.* 43, 6284-6294.

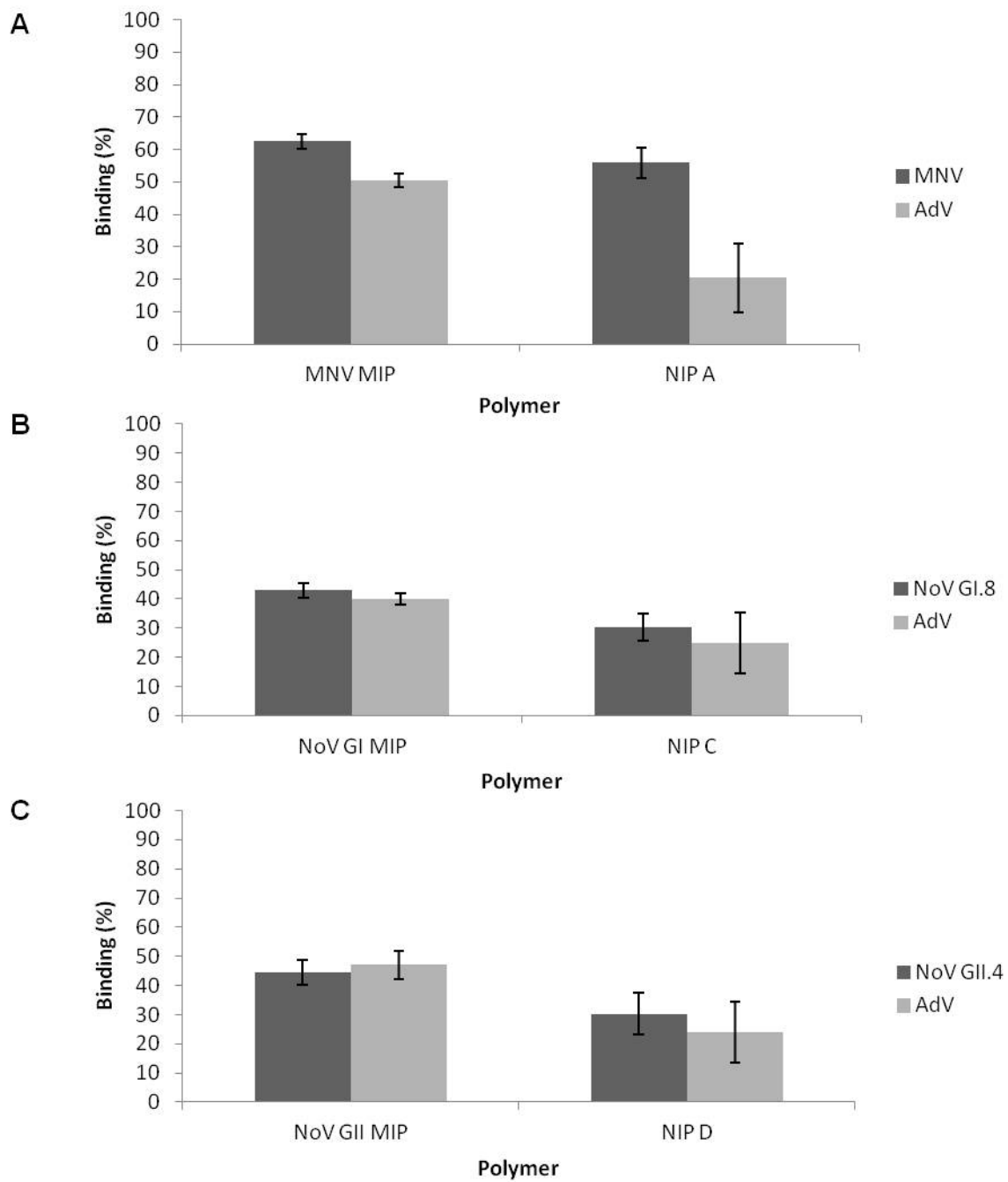

Figure 1. Percentage binding of MNV and AdV to the MNV-imprinted polymer and NIP-a (**A**), NoV GI.8 and AdV to the NoV GI-imprinted polymer and NIP-b (**B**), and NoV GII.4 and AdV to the NoV GII-imprinted polymer and NIP-c (**C**).

Table 1. Difference in percentage virus binding between VIPs and NIPs.

VIP column	NIP column	Virus added	$\Delta\%$ binding (VIP-NIP)			
			Repeat 1	Repeat 2	Mean	Sd
MNV VIP	NIP-a	MNV	11,62	1,54	6,58	7,13
		AdV	38,82	21,21	30,01	12,45
NoV GI VIP	NIP-b	NoV GI.8	17,51	7,75	12,63	6,90
		AdV	4,74	25,87	15,31	14,94
NoV GII VIP	NIP-c	NoV GII.4	16,27	12,17	14,22	2,90
		AdV	33,98	11,99	22,99	15,55

Table 2. Polymer flow rates (min/ml) for water.

Polymer	Repeat 1	Repeat 2	Repeat 3	Mean	Sd
MNV VIP	10,79	8,68	10,05	9,84	1,07
NIP-a	1,74	1,78	1,84	1,79	0,05
NoV GI VIP	7,13	7,88	7,08	7,36	0,45
NIP-b	2,67	2,78	2,74	2,73	0,06
NoV GII VIP	13,45	15,04	15,06	14,52	0,92
NIP-c	0,37	0,42	0,52	0,44	0,08

Chapter 9

Manuscript IV

Exposure to airborne noroviruses and other bioaerosol components at a wastewater treatment plant in Denmark

Katrine Uhrbrand, Anna Charlotte Schultz and Anne Mette Madsen

Published in Food and Environmental Virology 2011, 3:130-137

Exposure to Airborne Noroviruses and Other Bioaerosol Components at a Wastewater Treatment Plant in Denmark

Katrine Uhrbrand · Anna Charlotte Schultz ·
Anne Mette Madsen

Received: 29 August 2011 / Accepted: 30 September 2011 / Published online: 16 October 2011
© Springer Science+Business Media, LLC 2011

Abstract Exposure to bioaerosols associated with wastewater treatment processes may represent an occupational health risk for workers at wastewater treatment plants (WWTPs). A high frequency of acute symptoms in the gastrointestinal tract among the wastewater workers at a Danish WWTP has been reported. The objective of the study was therefore to examine the exposure of the workers to aerosolised microorganisms. Sampling of inhalable endotoxin, bacteria, moulds and viruses was performed on one occasion using personal samplers. Noroviruses (NoVs) and endotoxin were detected at concentrations that could pose an occupational health risk and possibly contribute to the increased frequency of gastrointestinal illness among the workers and should therefore be investigated further. In addition, positive correlations between exposure to endotoxin, bacteria, moulds and NoVs were found and indicate that the exposure to bioaerosols may be related to work tasks. This is the first study directly showing an occupational exposure to airborne NoVs by its detection in airborne dust.

Keywords Aerosols · Exposure · Norovirus · Endotoxin · Wastewater treatment plant · Gastroenteritis

Introduction

Workers at wastewater treatment plants (WWTPs) are potentially exposed to a wide variety of infectious and non-infectious microorganisms and microbial components (Douwes et al. 2001; Van Hooste et al. 2010). Aerosolised microorganisms may be present in many stages of the wastewater and sludge treatment process (Sanchez-Monedero et al. 2008). Thus, WWTP workers may be endangered by inhalation of these potentially harmful agents (Van Hooste et al. 2010). An increased incidence of gastrointestinal illness among workers at WWTPs compared with other control groups has been found (Khuder et al. 1998; Rylander 1999; Thorn et al. 2002). For instance, a prevalence of diarrhoea of 45% among wastewater workers compared with 3% in the control group was found by Rylander (1999). The increased incidence has been related to endotoxin exposure (Ivens et al. 1999; Rylander 1999). In addition, aerosolised bacteria (Lundholm and Rylander 1983) and viruses such as norovirus (NoV) (Clark et al. 1985; Clark 1987) have been suggested as a cause for the increased frequency of gastrointestinal illness.

The health of Danish wastewater workers was examined in questionnaire-based health surveys in 2007 and 2010 and revealed a high frequency (37%) of acute gastrointestinal symptoms among the wastewater workers (Thora Brendstrup & Birgitte Zwicky-Hauschild, personal communication). The objective of this study was therefore to examine whether workers at a WWTP in Copenhagen, Denmark, are exposed to aerosolised NoVs, adenoviruses (AdVs), endotoxins, moulds and bacteria, which could pose an occupational health risk and possibly explain the increased frequency of gastrointestinal illness.

K. Uhrbrand (✉) · A. C. Schultz
Division of Microbiology and Risk Assessment,
National Food Institute, Technical University of Denmark, DTU,
Mørkhøj Bygade 19, 2860 Søborg, Denmark
e-mail: kauhr@food.dtu.dk

A. M. Madsen
National Research Centre for the Working Environment,
Lersø Parkallé 105, 2100 Copenhagen Ø, Denmark

Materials and Methods

Sampling of Inhalable Aerosols

Sampling of bioaerosols was performed on 27 May 2010 by occupational hygienists at a wastewater treatment plant in Copenhagen, Denmark. For investigation of exposure to endotoxin, bacteria and moulds, personal dust sampling was conducted on one laboratory technician, one cleaning assistant, one storage worker and 13 workers performing observations of different wastewater processes. Four of the workers performing observations of the wastewater processes were additionally monitored for personal exposure to viral aerosols. Inhalable GSP samplers (CIS; BGI Inc, Waltham, MA; Madsen 2006b) with Teflon filters (1 µm; Millipore, Copenhagen, Denmark) or polycarbonate filters (1 µm; GE Water & Process Technologies, Trevose, USA) were used to collect either endotoxin or bacteria, moulds and viruses, respectively. Average sampling period was 242 min. Two stationary measurements of 'total dust' were conducted 1.5 m above ground level on an aeration basin. To ensure that the measured bioaerosols originated from the WWTP and not from neighbouring areas, a reference measure was taken upwind from the plant as described previously (Madsen 2006a).

Endotoxin Analysis

Extraction of dust from the Teflon filters and endotoxin analysis was performed as described previously (Madsen 2006b). Briefly, dust was extracted from filters in 10.0 ml pyrogen-free water with 0.05% Tween 20 by orbital shaking (300 rpm) at room temperature for 60 min and centrifugation at 1,000×g for 15 min. The supernatant was then analysed in duplicate for endotoxin using the kinetic Limulus Amoebocyte Lysate test (Kinetic-QCL endotoxin kit; Lonza, Walkersville, USA). A standard curve (ranging from 0.05 to 50) obtained from an *Escherichia coli* O55:B5 reference endotoxin was used to determine the concentrations in terms of endotoxin units (EU) (10.0 EU ≈ 1 ng).

Quantification of Bacteria and Moulds

Bacteria and moulds were extracted from the polycarbonate filters and quantified according to Madsen (2006b) using a modified version of the method for collection of airborne microorganisms on nucleopore filters, estimation and analysis (CAMNEA) developed by Palmgren et al. (1986). Dust from the polycarbonate filters was extracted in 10.0 ml sterile 0.05% Tween 80 and 0.85% NaCl aqueous solution by shaking for 15 min (500 rpm) at room temperature. The number of moulds cultivable on Dichloran Glycerol agar (DG 18 agar; Oxoid, Basingstoke, England)

at 25°C was counted. In addition, agar plates were incubated at 45°C to quantify cultivable *Aspergillus fumigatus*. Dominating mould species were identified using microscopy. Counts were made of the number of bacteria cultivable at 25°C on Nutrient agar (Oxoid, Basingstoke, England) with actidione (cycloheximide; 50 mg l⁻¹). Mesophilic actinomycetes and thermophilic actinomycetes (55°C) cultivable on, respectively, 10 and 100% Nutrient agar with actidione (cycloheximide; 50 mg l⁻¹) were identified, based on morphology and association with the agar medium, and counted. Finally, the total numbers of rod-shaped bacteria were determined using epi-fluorescence microscopy (Orthoplan; Leitz Wetzlar) with a magnification of 1,250 times after staining with 20 ppm acridine orange (Merck, Hellerup, Denmark) in acetate buffer for 30 s and filtration through a polycarbonate filter (25 mm, 0.4 µm; Nuclepore, Cambridge, MA, USA).

Processing and Extraction of Viral Nucleic Acids

Aerosolised viruses were eluted and extracted directly from the personal polycarbonate filters using the method described by Schultz et al. (2011). Briefly, filters were incubated for 15 min in 3 ml of NucliSENS lysis buffer (BioMerieux, Herlev, Denmark). Total nucleic acid purification was performed on the entire lysate using NucliSENS miniMAG system (BioMerieux) according to the manufactures' instructions. Nucleic acids were eluted in 100 µl of NucliSENS elution buffer.

The levels of viruses present in the wastewater on the day of air sampling were also determined. Samples of 100 ml were purified by centrifugation at 5,000×g for 20 min at 4°C. The supernatant was concentrated by filtration using a positively charged polyamid filter (47 mm, 0.45 µm; Sartorius Steadim, Taastrup, Denmark). Viral genomes were extracted from the filter as described above.

Detection and Quantification of Viruses

Viruses were detected in triplicates on a 96-well plate format of ABI StepOne (Applied Biosystems, Nærum, Denmark).

NoV genogroup (G)I, GII and MC₀ RNA were detected by reverse transcription (RT)–real-time polymerase chain reaction (qPCR) using the RNA UltraSense one-step quantitative RT-PCR system (Invitrogen, Taastrup, Denmark) and previously described primers and probes for NoV GI (Da Silva et al. 2007; Svraka et al. 2007), NoV GII (Kageyama et al. 2003; Loisy et al. 2005) and MC₀ (Costafreda et al. 2006). The RT-qPCR was carried out in a total of 25 µl reaction mixture constituting 5 µl of extracted viral RNA and 20 µl of RT-qPCR reaction mixture containing 1× UltraSense reaction mix, 500 mM forward

primer, 900 mM reverse primer, 250 mM Probe, 1× Rox reference dye and 1× UltraSense enzyme mix. Reaction conditions were as previously described (Le Guyader et al. 2009).

AdV serotype 40/41 DNA was detected by qPCR as described by Jothikumar et al. (2005) using a QuantiTech Probe PCR kit (QIAGEN, Copenhagen, Denmark) with primers JTVXF/JTVXR and probe JTVXP.

Quantification was performed using standard curves generated from 10-fold dilution series of NoV GI.3b and NoV GII.4 RNA transcripts (Gentry et al. 2009), extracted MC₀ RNA or AdV DNA.

Estimation of Virus Recovery

Recombinant mengovirus, MC₀ (ATCC VR-2310, kindly provided by Prof. Albert Bosch, University of Barcelona, Spain) was used as a process control in both air and wastewater samples. MC₀ was chosen as it is non-pathogenic to humans and can be grown in cell culture (Costafreda et al. 2006). In addition correlation between recovery of MC₀ and NoV GI.3 and NoV GII.4 was seen in other investigations (Le Guyader et al. 2009; Uhrbrand et al. 2010). Dust filters were spiked with 10³ TCID₅₀ of MC₀ before being transferred to the NucliSENS lysis buffer, while 10³ TCID₅₀ was added to the 100 ml of wastewater after centrifugation. The recovery was calculated from the number of TCID₅₀ detected in the samples as a percentage to the number of spiked TCID₅₀ (Uhrbrand et al. 2010).

Results and Discussion

The personal exposure to endotoxin, presented as 8-h time-weighted averages (TWA), was between 0.2 and 64 EU m⁻³. The lowest exposure was found for a laboratory technician (sample C018), and the highest exposure for a person partly working with wastewater, high-pressure cleaning pumps and grass mowing around the aeration basin (sample C022; Fig. 1a).

The median personal exposure to endotoxin of 13 EU m⁻³ ($n = 16$) was lower than that often found in occupational settings where organic material is handled (Madsen 2006a), but similar to Danish waste collectors (Nielsen et al. 1997). The two stationary measurements were 1.6 and 1.7 EU m⁻³. These were slightly higher than the reference and similar to industrial areas in Denmark in May (Madsen 2006a), but lower than that found in Swiss (Oppliger et al. 2005) and Finnish (Laitinen et al. 1992) WWTPs and Swedish compost plants (Clark et al. 1983).

Exposure to endotoxin has primarily been linked to the development of respiratory problems such as inflammation and symptoms of the airways (Donham et al. 2000). However, a significantly increased rate of diarrhoea in workers exposed to endotoxin levels between 50 and 200 EU m⁻³ was reported among Dutch WWTP workers (Smit et al. 2005). Despite that a high frequency of workers reported diarrhoea (37%) in the health examination and questionnaire preceding our study, only one person, corresponding to 6.3%, exceeded the critical exposure level of 50 EU m⁻³ determined to correlate with increased risk of diarrhoea by Smit et al. (2005). Nevertheless, we cannot

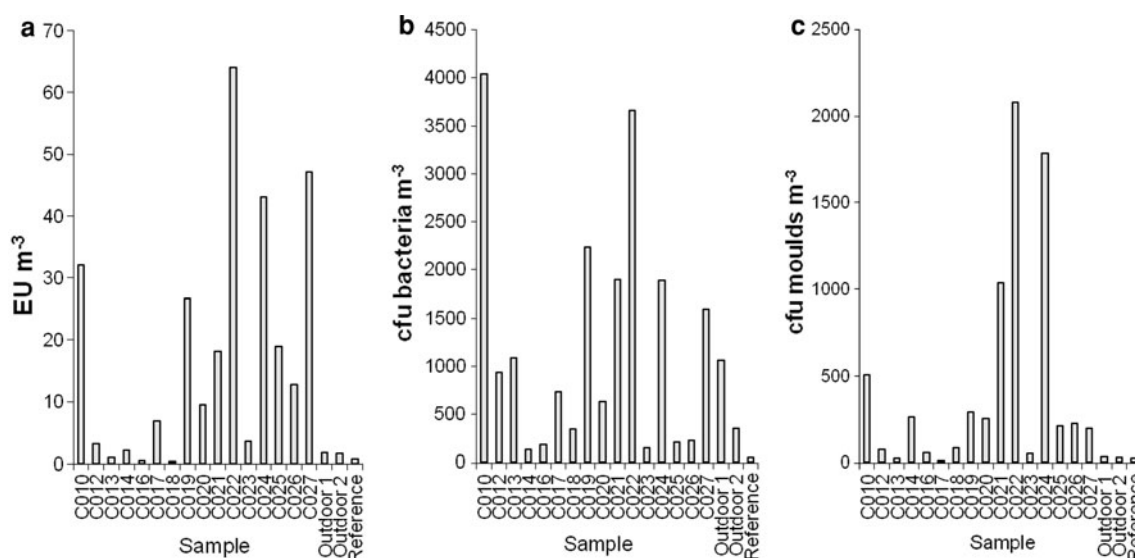

Fig. 1 Exposure to endotoxin [EU m⁻³] (a), mesophilic bacteria (excluding actinomycetes) [cfu m⁻³] (b) and moulds [cfu m⁻³] (c) presented as time-weighted averages. Each sample number

represents a person, 'outdoor' is stationary measurements taken at the plant above an aeration basin, and 'reference' is a reference measurement upwind the plant. EU Endotoxin units

exclude the possibility that endotoxin exposure to some extent may be the cause of some of the reported symptoms of gastroenteritis.

Exposure to mesophilic bacteria, presented as TWA, was between 133 and 4,044 cfu m⁻³ (median = 837 cfu m⁻³, $n = 16$; Fig. 1b). Lowest exposure was found for a person working with spare parts in a storeroom (sample C017), and highest for a person working with wastewater, high-pressure cleaning pumps and grass mowing around the aeration basin (sample C022). The bacterial exposure levels correlate with the lower end of exposures reported for Danish waste collectors (Nielsen et al. 1997). The stationary-measured average bacterial concentration of 710 cfu m⁻³ was higher than the reference sample, but at the level of an Austrian WWTP (Haas et al. 2010). Mesophilic actinomycetes were found in seven of 16 samples in concentrations of 97–525 cfu m⁻³ (median = 174 cfu m⁻³, $n = 16$). Thermophilic actinomycetes were found in two of 16 samples with an average concentration of 109 cfu m⁻³. Thermophilic actinomycetes have been associated with diseases of the airways (Pepys et al. 1963), and actinomycetes have been found in wastewater (Boon et al. 2002). Exposure of compost workers to actinomycetes in concentrations higher than that found in this study has been associated with a significantly higher frequency of health complaints and disease as well as higher concentrations of specific antibodies against actinomycetes (Bünger et al. 2000). Exposure to rod-shaped bacteria at concentrations greater than 600,000 bacteria m⁻³ has been associated with symptoms in the gastrointestinal tract (Melbostad et al. 1994). As the highest exposure (sample

C022) in our study was 6,400 rod-shaped bacteria m⁻³ and thus considerably lower than 600,000 m⁻³, it is doubtful that the gastrointestinal symptoms reported by the WWTP workers are caused by bacteria exposure, although it cannot be completely ruled out.

Personal exposure to moulds, presented as TWA, was between 10 and 2,079 cfu m⁻³ (median = 219 cfu m⁻³, $n = 16$; Fig. 1c). Stationary measurements showed an average concentration of 32 cfu m⁻³, which was higher than the outdoor reference of 25 cfu m⁻³, but well below the suggested occupational exposure limit (OEL) to diverse moulds of 10⁵ spores m⁻³ (Eduard 2009), and in the range of exposure to fungi found at Swiss WWTPs (Oppliger et al. 2005) and for Danish waste collectors (Nielsen et al. 1997). The dominating moulds *Cladosporium* spp., *Aspergillus* spp. and *Penicillium* spp. had previously been detected in an open composting facility and at a WWTP (Grisoli et al. 2009), while *A. fumigatus* found connected with handling of waste or compost by Clark et al. (1983) was not detected.

NoV GI was detected in all three RT-qPCR replicates in one of the four dust filter extracts (Table 1) with a viral load of 1,420 ± 1,140 genomes present on the filter corresponding to a TWA of 1,507 genomes m⁻³. NoV GII or AdV was detected in the airborne dust. The mean recovery efficiency of MC₀ spiked on the dust filters was 12.1 ± 2.3%. NoV GI, GII and AdV were found in both wastewater samples (Table 1) with a ratio between sand filter and aeration tank of 21.4, 18.7 and 34.7 for NoV GI, NoV GII and AdV, respectively. The recovery efficiency of MC₀ in wastewater samples collected from sand filter and

Table 1 Quantification of virus genomes detected on filters using personal dust samplers and in 100 ml wastewater samples

Sample	NoV GI ^a	NoV GII ^b	AdV ^c	MC ₀ ^d	
	Copies ± SD ^e	Copies ± SD	PCR U ± SD	PFU ± SD	Recovery efficiency %
<i>Dust filter</i>					
C019	ND ^f	ND	ND	(12.4 ± 3.33) × 10 ³	12.41
C022	(1.42 ± 1.14) × 10 ³	ND	ND	(14.9 ± 3.84) × 10 ³	14.93
C024	ND	ND	ND	(9.37 ± 1.76) × 10 ³	9.37
C027	ND	ND	ND	(11.6 ± 1.77) × 10 ³	11.60
<i>Wastewater</i>					
Sand filter	(179 ± 27.2) × 10 ³	(0.65 ± 0.22) × 10 ³	(5.76 ± 0.07) × 10 ³	(0.58 ± 0.20) × 10 ³	0.57
Aeration tank	(8.37 ± 3.34) × 10 ³	(0.04 ± 0.01) × 10 ³	(0.17 ± 0.06) × 10 ³	(0.77 ± 0.04) × 10 ³	0.77

The mean amount of detected genomes is based on 3 RT-qPCR replicates. For each sample, the recovery efficiency was calculated using the MC₀ process control

^a NoV GI norovirus genogroup I

^b NoV GII norovirus genogroup II

^c AdV adenovirus

^d MC₀ mengovirus

^e SD standard deviation

^f ND not detected

aeration tank was calculated to be 0.6 and 0.8%, respectively. The lower recovery efficiency of MC₀ observed for the wastewater samples compared with the air samples can be attributed to the difference in filter types used for the two matrixes as well MC₀ being added at slightly different steps. In addition, more RT-PCR inhibitors are likely to be present in the wastewater as it is a more impure matrix. Overall, the recovery of MC₀ process control found in our study may not directly reflect the recovery of enteric viruses naturally present in the air and wastewater samples. Spiked MC₀ has, for example, preciously been found to be less stable than spiked NoV under certain conditions during recovery from oysters and blue mussels (Comelli et al. 2008; Uhrbrand et al. 2010). Despite this, the percentage of MC₀ recovery is a valuable measurement of the relative method efficiency, which in this study shows a fairly robust recovery within the different samples types. The low recovery of MC₀ does, however, indicate that a fraction of the NoV and AdV present in both air and wastewater samples will most likely have been lost during processing.

Airborne transmission of NoV is believed to occur via inhalation and subsequent ingestion of virus particles (Cheesbrough et al. 2000; Marks et al. 2000, 2003). The level of aerosol exposure required to cause a NoV infection is unknown, but the infective dose (ID₅₀) of ingested NoVs is as low as 18 viral particles (Teunis et al. 2008). The 1,420 NoV GI copies detected on the dust filter might therefore indeed pose a risk to the worker. Moreover, the NoV exposure reported here is most likely underestimated as virus recovery was less than 100%.

The GSP samplers used in the study have not previously been applied for the collection of airborne viruses but has a high sampling efficiency for particles with aerodynamic diameters <50 µm at both high and low wind speeds (Aizenberg et al. 2000; Kenny et al. 1997, 1999). Furthermore, the samplers have previously been shown to be good for collecting bioaerosols (Madsen and Sharma 2008) and carbon black particles with physical diameters of 40–60 nm (Kerr et al. 2002). Filters with pore size of 1 µm were used in order to keep a constant airflow through the filter during the sampling. For future applications, optimisation of the method with regard to the selection of sampler, filter type and pore size could possibly increase the recovery efficiency.

The higher level of NoV GI found in the wastewater compared with NoV GII and AdV may explain why only NoV GI was detected on the dust filters as only a fraction of the virus present in the wastewater will probably be aerosolised and exceed the detection limit of the method. The lower amount of NoV GII present in the wastewater samples is slightly surprising since most other studies have reported NoV GII to be more prevalent than NoV GI in wastewater throughout the year with peaks during the

winter months (Haramoto et al. 2006; Katayama et al. 2008). Our findings are, however, concordant with a Swedish study of the wastewater, demonstrating a higher prevalence of NoV GI during summer months beginning in May (Nordgren et al. 2009). Since we have only monitored for NoV in the wastewater on one occasion, our findings may of course merely reflect epidemiological patterns in the community with emergence of NoV GI strains at the time of sampling rather than seasonal changes in NoV genogroups.

The risk of viral exposure to the workers may vary according to the time of year as seasonal variation in the concentration of viruses is known to occur (Haramoto et al. 2006; Katayama et al. 2008; Nordgren et al. 2009). Therefore, the workers might at some point be exposed to higher levels of aerosolised viruses than that detected in this study. Furthermore, the level of exposure to aerosols might be affected by factors such as geographical location, weather conditions, type and capacity of the treatment facility (Van Hooste et al. 2010). For instance, a higher number of airborne microorganisms such as coliphages have been found to correlate with the amount of wastewater treated in specific sites at one WWTP (Heinonen-Tanski et al. 2009). The exposure level may also be influenced by the degree of automation and optimised process operations, e.g. casing of dirty processes and use of equipment producing less aerosols (Heinonen-Tanski et al. 2009). Finally, meteorological conditions such as wind speed and direction, rainfall, humidity and temperature may affect the release and dispersal of the aerosols (Jones and Harrison 2004).

Upon exposure to NoV, the risk of developing illness will depend on the protective immunity status of the person, as some individuals will develop gastroenteritis, while others will develop asymptomatic infection and some show no sign of infection (Lopman et al. 2008). Hence, assessing the actual risk of a worker getting infected and developing symptomatic disease following exposure to NoV is complicated. Nevertheless, when disregarding possible innate resistance, the workers may be at risk of repeated NoV infections, especially if exposed to a variety of different strains, as only strain-specific short-term immunity is thought to occur (Vinjé 2010).

Overall, positive correlations were found between exposures to endotoxin, mould and bacteria as congruence between the workers exposure to the highest and lowest levels of these agents was found. The calculated Pearson correlation between the exposure to bacteria and mould ($r = 0.64$, $P = 0.008$), bacteria and endotoxin ($r = 0.77$, $P = 0.0002$), and mould and endotoxin ($r = 0.79$, $P = 0.0001$) was in all cases significant. Moreover, the fact that NoV GI was detected on the dust filter originating from the worker (sample C022) exposed to high levels of

endotoxin, mould and bacteria suggests that a correlation between the exposure to viruses and these agents may also exist. Finally, the correlations indicate that the exposure level to bioaerosols may be related to work tasks and possibly also to the location of the workers and their proximity to the source within the WWTP. In order to minimise the occupational exposure of aerosolised agents, we therefore recommend that further investigations should be conducted to identify the source of the contamination and determine specific work tasks and sites at the WWTP with high risk of exposure. Control strategies like implementation of sanitary measures, such as respiratory protection, should subsequently be established for high-risk classified sites and working tasks.

In summary, exposure to bacteria and moulds was well below suggested OELs for all studied workers, while the exposure to endotoxin reached a critical level for one of 16 workers and NoV was detected in airborne dust in concentrations above the known infectious dose. The workers at this Danish WWTP might therefore potentially be at risk of exposure to endotoxin and infections caused by gastrointestinal viruses like NoVs, which could possibly contribute to the increased frequency of gastrointestinal illness among the workers at the WWTP. However, the present study is limited by the low number of samples, and the fact the results obtained in this study cannot be related to the actual frequency of gastrointestinal illness as the health survey on the workers was not performed simultaneously with the exposure study. Hence, a more extensive study is needed to definitely determine whether there is indeed a connection between the exposure and gastroenteritis. To our knowledge, this is the first study that demonstrates occupational exposure to aerosolised NoV by its detection and quantification on a workers dust filter. Since little is known about exposure and transmission of airborne NoVs, more research should be done to investigate the extent and actual risk of exposure to aerosolised NoVs.

Acknowledgments The work was partially supported by grant NKJ-130 from the Nordic Joint Committee for Agricultural Research. We highly acknowledged Thora Brendstrup and Birgitte Zwicky-Hauschild at Occupational Health Consultancy, City of Copenhagen, as well as Albert Dam for initiating this study. We thank Margit W. Frederiksen for skilful technical assistance and the WWTP workers for their participation in the project.

References

- Aizenberg, V., Grinshpun, S. A., Willeke, K., Smith, J., & Baron, P. A. (2000). Performance characteristics of the button personal inhalable aerosol sampler. *AIHAJ*, *61*, 398–404.
- Boon, N., De Windt, W., Verstraete, W., & Top, E. M. (2002). Evaluation of nested PCR-DGGE (denaturing gradient gel electrophoresis) with group-specific 16S rRNA primers for the analysis of bacterial communities from different wastewater treatment plants. *FEMS Microbiology and Ecology*, *39*, 101–112.
- Bünger, J., Antlauf-Lammers, M., Schulz, T. G., Westphal, G. A., Müller, M. M., Ruhnau, P., et al. (2000). Health complaints and immunological markers of exposure to bioaerosols among biowaste collectors and compost workers. *Occupational and Environmental Medicine*, *57*, 458–464.
- Cheesbrough, J. S., Green, J., Gallimore, C. I., Wright, P. A., & Brown, D. W. G. (2000). Widespread environmental contamination with Norwalk-like viruses (NLV) detected in a prolonged hotel outbreak of gastroenteritis. *Epidemiology and Infection*, *125*, 93–98.
- Clark, C. S. (1987). Potential and actual biological related health risks of wastewater industry employment. *Journal of Water Pollution Control Federation*, *59*, 999–1008.
- Clark, C. S., Linnemann, J., & Gartside, P. S. (1985). Serologic survey of rotavirus, Norwalk agent and prototheca wickerhamii in wastewater workers. *American Journal of Public Health*, *75*, 83–85.
- Clark, C. S., Rylander, R., & Larsson, L. (1983). Levels of gram-negative bacteria, *Aspergillus fumigatus*, dust, and endotoxin at compost plants. *Applied and Environmental Microbiology*, *45*, 1501–1505.
- Comelli, H. L., Rimstad, E., Larsen, S., & Myrnel, M. (2008). Detection of norovirus genotype I.3b and II.4 in bioaccumulated blue mussels using different virus recovery methods. *International Journal of Food Microbiology*, *127*, 53–59.
- Costafreda, M. I., Bosch, A., & Rosa, M. (2006). Development, evaluation, and standardization of a real-time TaqMan reverse transcription-PCR assay for quantification of hepatitis A virus in clinical and shellfish samples. *Applied and Environmental Microbiology*, *72*, 3846–3855.
- Da Silva, A. K., Le Saux, J. C., Parnaudeau, S., Pommepuy, M., Elimelech, M., & Le Guyader, F. (2007). Evaluation of removal of noroviruses during wastewater treatment, using real-time reverse transcription-PCR: Different behaviors of genogroups I and II. *Applied and Environmental Microbiology*, *73*, 7891–7897.
- Donham, K. J., Cumro, D., Reynolds, S. J., & Merchant, J. A. (2000). Dose-response relationships between occupational aerosol exposures and cross-shift declines of lung function in poultry workers: Recommendations for exposure limits. *Journal of Occupational and Environmental Medicine*, *42*, 260–269.
- Douwes, J., Mannetje, A., & Heederik, D. (2001). Work-related symptoms in sewage treatment workers. *Annals of Agricultural and Environmental Medicine*, *8*, 39–45.
- Eduard, W. (2009). Fungal spores: A critical review of the toxicological and epidemiological evidence as a basis for occupational exposure limit setting. *Critical Reviews in Toxicology*, *39*, 799–864.
- Gentry, J., Vinjé, J., & Lipp, E. K. (2009). A rapid and efficient method for quantitation of genogroups I and II norovirus from oysters and application in other complex environmental samples. *Journal of Virological Methods*, *156*, 59–65.
- Grisoli, P., Rodolfi, M., Villani, S., Grignani, E., Cottica, D., Berri, A., et al. (2009). Assessment of airborne microorganism contamination in an industrial area characterized by an open composting facility and a wastewater treatment plant. *Environmental Research*, *109*, 135–142.
- Haas, D., Unteregger, M., Habib, J., Galler, H., Marth, E., & Reinthaler, F. F. (2010). Exposure to Bioaerosol from sewage systems. *Water, Air, and Soil Pollution*, *207*, 49–56.
- Haramoto, E., Katayama, H., Oguma, K., Ohgaki, S., Yamashita, H., Tajima, A., et al. (2006). Seasonal profiles of human noroviruses and indicator bacteria in a wastewater treatment plant in Tokyo, Japan. *Water Science and Technology*, *54*, 301–308.

- Heinonen-Tanski, H., Reponen, T., & Koivunen, J. (2009). Airborne enteric coliphages and bacteria in sewage treatment plants. *Water Research*, *43*, 2558–2566.
- Ivens, U. I., Breum, N. O., Ebbelohj, N., Nielsen, B. H., Poulsen, O. M., & Wurtz, H. (1999). Exposure-response relationship between gastrointestinal problems among waste collectors and bioaerosol exposure. *Scandinavian Journal of Work, Environment and Health*, *25*, 238–245.
- Jones, A. M., & Harrison, R. M. (2004). The effects of meteorological factors on atmospheric bioaerosol concentrations—A review. *Science of the Total Environment*, *326*, 151–180.
- Jothikumar, N., Cromeans, T. L., Hill, V. R., Lu, X., Sobsey, M. D., & Erdman, D. D. (2005). Quantitative real-time PCR assays for detection of human adenoviruses and identification of serotypes 40 and 41. *Applied and Environmental Microbiology*, *71*, 3131–3136.
- Kageyama, T., Kojima, S., Shinohara, M., Uchida, K., Fukushi, S., Hoshino, F. B., et al. (2003). Broadly reactive and highly sensitive assay for Norwalk-like viruses based on real-time quantitative reverse transcription-PCR. *Journal of Clinical Microbiology*, *41*, 1548.
- Katayama, H., Haramoto, E., Oguma, K., Yamashita, H., Tajima, A., Nakajima, H., et al. (2008). One-year monthly quantitative survey of noroviruses, enteroviruses, and adenoviruses in wastewater collected from six plants in Japan. *Water Research*, *42*, 1441–1448.
- Kenny, L. C., Aitken, R. J., Baldwin, P. E. J., Beaumont, G. C., & Maynard, A. D. (1999). The sampling efficiency of personal inhalable aerosol samplers in low air movement environments. *Journal of Aerosol Science*, *30*, 627–638.
- Kenny, L. C., Aitken, R., Chalmers, C., Fabrières, J. F., Gonzalez-Fernandez, E., Kromhout, H., et al. (1997). A collaborative European study of personal inhalable aerosol sampler performance. *Annals of Occupational Hygiene*, *41*, 135–153.
- Kerr, S. M., Muranko, H. J., & Vincent, J. H. (2002). Personal sampling for inhalable aerosol exposures of carbon black manufacturing industry workers. *Applied Occupational and Environmental Hygiene*, *17*, 681–692.
- Khuder, S. A., Arthur, T., Bisesi, M. S., & Schaub, E. A. (1998). Prevalence of infectious diseases and associated symptoms in wastewater treatment workers. *American Journal of Industrial Medicine*, *33*, 571–577.
- Laitinen, S., Nevalainen, A., Kotimaa, M., Liesivuori, J., & Martikainen, P. J. (1992). Relationship between bacterial counts and endotoxin concentrations in the air of wastewater treatment plants. *Applied and Environmental Microbiology*, *58*, 3774–3776.
- Le Guyader, F., Parnaudeau, S., Schaeffer, J., Bosch, A., Loisy, F., Pommepuy, M., et al. (2009). Detection and quantification of noroviruses in shellfish. *Applied and Environmental Microbiology*, *75*, 618–624.
- Loisy, F., Atmar, R. L., Guillon, P., Le Cann, P., Pommepuy, M., & Le Guyader, F. S. (2005). Real-time RT-PCR for norovirus screening in shellfish. *Journal of Virological Methods*, *123*, 1–7.
- Lopman, B., Zambon, M., & Brown, D. W. (2008). The evolution of Norovirus, “the Gastric Flu”. *PloS Medicine*, *5*, 187–189.
- Lundholm, M., & Rylander, R. (1983). Work related symptoms among sewage workers. *British Journal of Industrial Medicine*, *40*, 325–329.
- Madsen, A. M. (2006a). Airborne endotoxin in different background environments and seasons. *Annals of Agricultural and Environmental Medicine*, *13*, 81–86.
- Madsen, A. M. (2006b). Exposure to airborne microbial components in autumn and spring during work at Danish biofuel plants. *Annals of Occupational Hygiene*, *50*, 821–831.
- Madsen, A. M., & Sharma, A. K. (2008). Sampling of high amounts of bioaerosols using a high-volume electrostatic field sampler. *Annals of Occupational Hygiene*, *52*, 167–176.
- Marks, P. J., Vipond, I. B., Carlisle, D., Deakin, D., Fey, R. E., & Caul, E. O. (2000). Evidence for airborne transmission of norwalk-like virus (NLV) in a hotel restaurant. *Epidemiology and Infection*, *124*, 481–487.
- Marks, P. J., Vipond, I. B., Regan, F. M., Wedgwood, K., Fey, R. E., & Caul, E. O. (2003). A school outbreak of Norwalk-like virus: Evidence for airborne transmission. *Epidemiology and Infection*, *131*, 727–736.
- Melbostad, E., Eduard, W., Skogstad, A., Sandven, P., Lassen, J., Sostrand, P., et al. (1994). Exposure to bacterial aerosols and work-related symptoms in sewage workers. *American Journal of Industrial Medicine*, *25*, 59–63.
- Nielsen, E. M., Breum, N. O., Nielsen, B. H., Würtz, H., Poulsen, O. M., & Midtgaard, U. (1997). Bioaerosol exposure in waste collection: A comparative study on the significance of collection equipment, type of waste and seasonal variation. *Annals of Occupational Hygiene*, *41*, 325–344.
- Nordgren, J., Matussek, A., Mattsson, A., Svensson, L., & Lindgren, P. E. (2009). Prevalence of norovirus and factors influencing virus concentrations during one year in a full-scale wastewater treatment plant. *Water Research*, *43*, 1117–1125.
- Oppliger, A., Duc, T. V., & Hilfiker, S. (2005). Influence of seasons and sampling strategy on assessment of bioaerosols in sewage treatment plants in Switzerland. *Annals of Occupational Hygiene*, *49*, 393–400.
- Palmgren, U., Ström, G., Blomquist, G., & Malmberg, P. (1986). Collection of airborne microorganisms on nucleopore filters, estimation and analysis-CAMNEA method. *Journal of Applied Bacteriology*, *61*, 401–406.
- Pepys, J., Jenkins, P. A., Festenstein, G. N., Gregory, P. H., Lacey, M. E., & Skinner, F. A. (1963). Farmer’s lung. Thermophilic actinomycetes as a source of “Farmer’s Lung Hay” antigen. *Lancet*, *2*, 607–611.
- Rylander, R. (1999). Health effects among workers in sewage treatment plants. *Occupational and Environmental Medicine*, *56*, 354–357.
- Sanchez-Monedero, M. A., Aguilar, M. I., Fenoll, R., & Roig, A. (2008). Effect of the aeration system on the levels of airborne microorganisms generated at wastewater treatment plants. *Water Research*, *42*, 3739–3744.
- Schultz, A. C., Perelle, S., Di Pasquale, S., Kovac, K., De Medici, D., Fach, P., et al. (2011). Collaborative validation of a rapid method for efficient virus concentration in bottled water. *International Journal of Food Microbiology*, *145*, 158–166.
- Smit, L. A. M., Spaan, S., & Heederik, D. (2005). Endotoxin exposure and symptoms in wastewater treatment workers. *American Journal of Industrial Medicine*, *48*, 30–39.
- Svraka, S., Duizer, E., Vennema, H., Bruin, E. D., Veer, B. V. D., Dorresteyn, B., et al. (2007). Etiological role of viruses in outbreaks of acute gastroenteritis in the Netherlands from 1994 through 2005. *Journal of Clinical Microbiology*, *45*, 1389–1394.
- Teunis, P. F. M., Moe, C. L., Liu, P., Miller, S. E., Lindesmith, L., Baric, R. S., et al. (2008). Norwalk virus: How infectious is it? *Journal of Medical Virology*, *80*, 1468–1476.
- Thorn, J., Beijer, L., & Rylander, R. (2002). Work related symptoms among sewage workers: A nationwide survey in Sweden. *Occupational and Environmental Medicine*, *59*, 562–566.
- Uhrbrand, K., Myrmel, M., Maunula, L., Vainio, K., Trebbien, R., Nørrung, B., et al. (2010). Evaluation of a rapid method for recovery of norovirus and hepatitis A virus from oysters

- and blue mussels. *Journal of Virological Methods*, 169, 70–78.
- Van Hooste, W., Charlier, A. M., Rotsaert, P., Bulterys, S., Moens, G., van Sprundel, M., et al. (2010). Work-related *Helicobacter pylori* infection among sewage workers in municipal wastewater treatment plants in Belgium. *Occupational and Environmental Medicine*, 67, 91–97.
- Vinje, J. (2010). A Norovirus vaccine on the horizon? *Journal of Infectious Diseases*, 202, 1623–1625.

Chapter 10

Manuscript V

Inactivation of norovirus surrogates on surfaces and raspberries by steam-ultrasound treatment

Anna Charlotte Schultz, Katrine Uhrbrand, Birgit Nørrung and Anders Dalsgaard

Published in Journal of Food Protection 2012, 2:376-381

Research Note

Inactivation of Norovirus Surrogates on Surfaces and Raspberries by Steam-Ultrasound Treatment

ANNA CHARLOTTE SCHULTZ,^{1,2*} KATRINE UHRBRAND,¹ BIRGIT NØRRUNG,² AND ANDERS DALSGAARD²

¹Division of Microbiology and Risk Assessment, National Food Institute, Technical University of Denmark, DTU, Mørkhøj Bygade 19, DK-2860 Søborg, Denmark; and ²Department of Veterinary Disease Biology, Faculty of Life Sciences, University of Copenhagen, Grønnegaardsvej 15, DK-1870 Frederiksberg C, Denmark

MS 11-271: Received 2 June 2011/Accepted 23 September 2011

ABSTRACT

Human disease outbreaks caused by norovirus (NoV) following consumption of contaminated raspberries are an increasing problem. An efficient method to decontaminate the fragile raspberries and the equipment used for processing would be an important step in ensuring food safety. A potential surface treatment that combines pressurized steam and high-power ultrasound (steam-ultrasound) was assessed for its efficacy to inactivate human NoV surrogates: coliphage (MS2), feline calicivirus (FCV), and murine norovirus (MNV) inoculated on plastic surfaces and MS2 inoculated on fresh raspberries. The amounts of infectious virus and viral genomes were determined by plaque assay and reverse transcription–real time quantitative PCR (RT-qPCR), respectively. On plastic surfaces, an inactivation of >99.99% was obtained for both MS2 and FCV, corresponding to a 9.1-log and >4.8-log reduction after 1 or 3 s of treatment, respectively; while a 3.7-log (99.97%) reduction of MNV was reached after 3 s of treatment. However, on fresh raspberries only a 1-log reduction (~89%) of MS2 could be achieved after 1 s of treatment, at which point damage to the texture of the fresh raspberries was evident. Increasing treatment time (0 to 3 s) resulted in negligible reductions of viral genome titers of MS2, FCV, and MNV on plastic surfaces as well as of MS2 inoculated on raspberries. Steam-ultrasound treatment in its current format does not appear to be an appropriate method to achieve sufficient decontamination of NoV-contaminated raspberries. However, steam-ultrasound may be used to decontaminate smooth surface areas and utensils in food production and processing environments.

Human noroviruses (NoVs) cause gastroenteritis and are transmitted through the fecal-oral route (4). Infected persons may excrete up to 10⁸ viral particles per ml of feces and vomitus (22). With an infective dose as low as 18 viral particles (44), the infection is highly contagious and spreads rapidly through direct person-to-person contact or indirectly via contaminated food and water. NoVs are extremely resistant to environmental stress, which enables them to survive and spread outside their host. NoVs have repeatedly been implicated in large-scale disease outbreaks worldwide (17, 18, 22) and have been identified as the most frequent cause of foodborne disease outbreaks in most Western countries, including Denmark (3) and the United States (11).

Recently, reports of NoV disease outbreaks associated with soft fruits have increased (16, 20, 24, 27). Fresh produce may be contaminated with NoV at any point in the production chain (26). NoVs persist in the environment and can be found in the influent and effluent of wastewater treatment plants (12, 30). Due to limited water resources, contaminated, poor-quality surface water is increasingly used for irrigation of food crops, which may subsequently be implicated in NoV disease outbreaks (38, 42, 45, 47). Moreover, the surface of soft fruits may be fecally

contaminated by infected food handlers as a result of inadequate personal hygiene (22, 38).

Decontamination of soft fruits, e.g., raspberries, is complicated by their fragile nature. Consequently, postharvest sanitizing technologies used by the industry are minimal and, even if used, have a limited effect on the removal or inactivation of NoVs (1) as they are relatively resistant to heat (18), disinfection (19), and alkaline as well as acid conditions (10). This lack of appropriate decontamination methods, combined with the fact that soft fruits are often eaten raw, makes them particularly hazardous to consumers (36, 39).

Human NoV cannot be cultivated *in vitro*, and inactivation studies of human NoV in food are rare and have relied on reverse transcription (RT)–real time quantitative PCR (RT-qPCR) detection for the determination of NoV reduction during mild thermal pasteurization, freezing, and frozen storage of berries and herbs (5, 8, 9). As a response to this, various studies of persistence against heat treatment, high-intensity ultrasound, or high pressure processing have been conducted with the cultivable surrogates of NoV, i.e., the F-RNA coliphage MS2 and the genetically related feline calicivirus (FCV) and murine norovirus (MNV) (5, 10, 15, 21, 43, 46), which like the human NoV, are nonenveloped viruses belonging to the family *Caliciviridae*.

* Author for correspondence. Tel: +45 35887000; Fax: +45 35887001; E-mail: acsc@food.dtu.dk.

Steam-ultrasound technology is a new potential decontamination method for microorganisms on food and food contact surfaces. The technology combines pressurized steam and high-power ultrasound to give an enhanced effect of the steam by the efficient removal of the protective boundary air present on the surface by setting the air in a state of intensified molecular oscillation (41). This allows the steam to penetrate into the microstructures and cavities on surfaces more easily, thus resulting in a reduction of microorganisms on surfaces within seconds. Such a rapid treatment could be particularly valuable for decontamination of food surfaces as it would result in minimal changes in the quality of the food product. Previously, a few seconds of steam-ultrasound treatment has, with success, been shown to reduce *Campylobacter* spp. by 2.5 log CFU per broiler carcass (7) and *Salmonella* spp. on skin and meat surfaces of pork samples by 1.1 log and 3.3 log CFU/cm², respectively (28). As a sanitizing process, steam-ultrasound is attractive as it has advantages compared with chemical disinfection such as chlorine or peroxyacetic acids (1). The steam-ultrasound process is, for example, unlikely to produce cytotoxicity, and its efficacy has been shown not to be affected by the number of bacteria inoculated on skin and meat surfaces (28).

The objectives of the present study were (i) to assess the efficiency of the steam-ultrasound technology to inactivate MS2, FCV, and MNV on contaminated surfaces and MS2 on artificially contaminated raspberries and (ii) to evaluate possible negative impacts of the use of steam-ultrasound on the quality and texture of the raspberries. Also, the reduction in viral infectivity was compared with the stability of viral RNA.

MATERIALS AND METHODS

Viruses used for inactivation experiments. Reference strains of MS2 (NCO12487), FCV (F9, ATCC VR-782), and MNV (kindly provided by Dr. Herbert Skip Virgin, Washington University, St. Louis, MO) were propagated in *Salmonella* Typhimurium WG49 type 3 Nal^r (F'42 lac::Tn5) (NCTC 12484), Crandell-Reese feline kidney (CRFK) cells (ATCC CCL-94), and RAW 264.7 cells (ATCC TIB-71), respectively. The resulting viral stocks of MS2, FCV, and MNV were titrated by plaque assay (2, 6, 10) to 6.32×10^{10} , 3.17×10^7 , and 2.67×10^7 PFU/ml, respectively.

Virus preparation. The virucidal effect of steam-ultrasound treatment was tested on the NoV surrogates: MS2, FCV, and MNV. Determination of infectious viruses using plaque assay and quantification of viral genomes using RT-qPCR were performed in parallel on three separate experiments for each virus. Surfaces of petri dishes (49-mm diameter; Hounisen, Risskov, Denmark) and fresh raspberries (10-g portions) were inoculated by distributing 140 μ l of MS2 stock solution in 10- μ l droplets. Likewise, surfaces of petri dishes were inoculated with 100 μ l of FCV and MNV stock solutions. All samples were air dried in a laminar flow hood for 30 min and stored on ice until steam-ultrasound treatment was given.

Plaque assays. Quantification of infective viruses present in the samples was done using plaque assays. Viruses were released from the surfaces of the petri dishes by rinsing with 6.0 ml of Tris-HCl (0.1 M)-glycine (0.05 M)-beef extract (1%, wt/vol) (Sigma-Aldrich, Brønby, Denmark) pH 9.5 (TGBE) buffer for MS2 and 1.0 ml of phosphate-buffered saline (PBS) pH 7.2 \pm 0.2 (Oxoid,

Greve, Denmark) for FCV and MNV. Infectious viruses were determined using double layer agar plaque assays in duplicate of 10-fold dilutions of MS2 in 0.1% peptone water (Oxoid) (2) and in triplicate of 10-fold dilutions of FCV or MNV in PBS pH 7.2 \pm 0.2 (10).

MS2 inoculated on raspberries was released by the addition of 16.0 ml of TGBE buffer, followed by gentle shaking for 20 min at room temperature before MS2 was separated from the berry tissue by centrifugation at $10,000 \times g$ for 30 min at 4°C. Tenfold serial dilutions were prepared in 0.1% peptone water, and MS2 plaque assays were done as described above.

Extraction of viral RNA. Viral RNA was extracted directly from the plastic surfaces using the QIAamp viral RNA minikit (Qiagen, Sollentuna, Sweden) for MS2 particles and the NucliSens magnetic kit and miniMAG instrument (bioMérieux, Herlev, Denmark) for FCV and MNV. The protocols recommended by the manufacturers were followed, and the RNA was eluted in a final volume of 100 μ l.

From the raspberry, MS2 was released using a modified version of the method described by Dubois et al. (14). Briefly, 16.0 ml of TGBE buffer was added to the raspberries, followed by gentle shaking for 20 min at room temperature and then by centrifugation at $10,000 \times g$ for 30 min. The virus-containing solution was adjusted to pH 7.0 \pm 0.2 with 9.5 M HCl and incubated with 114 U of pectinase (Pectinex, Sigma-Aldrich) for 10 min at room temperature. Viruses were precipitated by the addition of 4 ml of a solution of 10% polyethylene glycol 8000 (Sigma-Aldrich) per 0.3 M NaCl, incubated for 1 h with gentle shaking at 4°C, and concentrated by centrifugation at $10,000 \times g$ at 4°C for 30 min. The pellet was resuspended in 0.4 ml of PBS pH 7.2 \pm 0.2, and the virus suspension was clarified by extraction with one volume of chloroform-butanol (1:1) followed by centrifugation at $6,000 \times g$ at 4°C for 15 min. Finally, MS2 RNA was extracted using the QIAamp viral RNA minikit from 140 μ l of the virus extract according to the manufacturer's instructions. RNA was eluted in 100 μ l and was either immediately analyzed by RT-qPCR or stored at -80°C until use.

Viral genome quantification. The genome stability of MS2, FCV, and MNV after steam-ultrasound treatment was determined by RT-qPCR in duplicate from each suspension of extracted nucleic acids. The following oligonucleotide forward and reverse primers and probe were used: MS2-TM2-f, MS2-TM2-r, and MS2-TM2-pr for MS2 (13), G54763F, G54863R, and G54808P for MNV (37), and FCVf, FCVr, and FCVp for FCV (25). Detection was performed on a 96-well plate format of an ABI Prism 7900HT (Applied Biosystems, Naerum, Denmark).

Detection of MS2 RNA, extracted from steam-ultrasound-treated virus on petri dishes and raspberry samples, was performed using a two-step TaqMan RT-PCR. cDNA was synthesized from 10 μ l of RNA in a 20- μ l reaction volume using SuperScript III reverse transcriptase kit (Invitrogen, Taastrup, Denmark) containing 200 nM reverse primer, 0.4 mM (each) deoxynucleoside triphosphate, $1 \times$ First-Strand Buffer ($5 \times$), 8 mM dithiothreitol, and 40 U of RNase Inhibitor (Invitrogen). The RT was carried out at 48°C for 50 min followed by 15 min at 70°C on a DNA Engine TETRAD2 Peltier Thermal Cycler (Bio-Rad, Denmark). Then 2.0 μ l of cDNA was amplified in a total of 25.0 μ l of TaqMan universal PCR master mix (Qiagen), containing 12.5 μ l of $2 \times$ TaqMan U.P. mix (Applied Biosystems), 500 nM primers, and 200 nM probe. The following reaction conditions were applied: 50°C for 2 min and 95°C for 10 min, followed by 50 cycles at 95°C for 15 s and 60°C for 1 min.

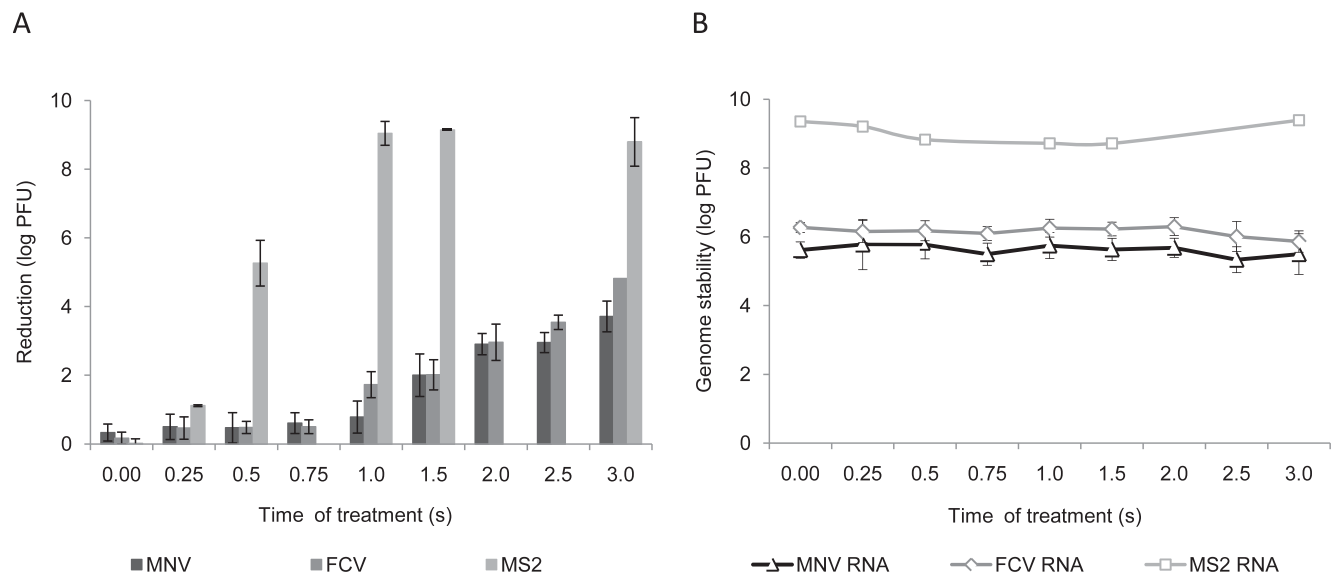

FIGURE 1. Inactivation by plaque assay (A) and genome stability by real-time RT-PCR (B) of pure MS2, feline calicivirus (FCV), and murine norovirus (MNV) on plastic surfaces after steam-ultrasound treatment for various lengths of time.

Detection of FCV and MNV RNA extracted from steam-ultrasound-treated virus on petri dishes was done using the RNA Ultrasense one-step qRT-PCR kit (Invitrogen). The RT-qPCR was carried out in a total of 25 μ l of reaction mixture consisting of 5 μ l of extracted viral RNA and 20 μ l of RT-qPCR reaction mixture (containing 1 \times UltraSense reaction mix, 500 mM forward primer, 900 mM reverse primer, 250 mM probe, 1 \times Rox reference dye, and 1 \times UltraSense enzyme mix) under the following RT-qPCR reaction conditions: 55°C for 1 h and 95°C for 5 min, followed by 45 cycles at 95°C for 15 s, 60°C for 1 min, and 65°C for 1 min.

Quantification was done using standard curves generated from 10-fold dilution series of extracted nucleic acids from the virus stocks using QIAamp viral RNA minikit for MS2 and NucliSens reagents and miniMAG platform for FCV and MNV.

Inactivation by steam-ultrasound treatment. Samples were treated with steam in combination with ultrasound using the SonoSteam technique. A proof-of-concept treatment apparatus generating a frequency of ultrasound between 30 and 40 kHz, a sound pressure level (SPL) up to 160 dB (2,000 Pa), and a steam temperature at 130°C during treatment was used (41). Petri dishes containing pure virus and virus-contaminated raspberries were treated individually in a closed treatment chamber mounted with a row of specially designed nozzles that generated airborne ultrasound by the means of a high-pressure feed of steam. During the treatment the petri dishes containing the samples were secured with clamps to an iron grid in the chamber and covered with a wire mesh. Treatment times of 0, 0.25, 0.5, 1.0, and 3.0 s were given to the MS2-contaminated petri dishes; 0, 0.25, 0.5, 0.75, 1.0, 1.5, 2.0, 2.5, or 3.0 s to the dishes containing FCV and MNV; and 0, 0.25, 0.5, or 1 s to the contaminated raspberries.

Texture of raspberries after treatment. To test the effect of 0.25, 0.5, and 1 s of steam-ultrasound treatment on the appearance of the raspberries, the texture was visually evaluated immediately after treatment and after 1 and 12 days of storage at 4°C and was compared with the texture of nontreated raspberry controls. The evaluation was done subjectively according to the parameters fluid loss and firmness of the raspberries.

Statistical analysis. The significance of genome reductions as a function of treatment time and the inactivation of MS2 on raspberries immediately after steam-ultrasound treatment and after further frozen storage was analyzed using one-way analysis of variance in Microsoft Office Excel (Microsoft, Redmond, WA). Results with *P* values <0.05 were considered statistically significant.

RESULTS AND DISCUSSION

The inactivation and genome stability of viruses were examined after steam-ultrasound treatment of petri dish plastic surfaces containing pure dried samples of MS2, FCV, and MNV and of raspberries artificially contaminated with MS2.

Effect of steam-ultrasound treatment on viral infectivity. The reduction in infective MS2, FCV, and MNV on plastic surfaces after receiving steam-ultrasound treatments for various lengths of time is depicted in Figure 1A. The reduction in infective MS2 present on fresh raspberries analyzed immediately after receiving steam-ultrasound treatment for various lengths of time, as well as after subsequent storage at -20°C for 3 weeks, is shown in Figure 2. In all cases, the average recovery of PFU was based on three experiments. In samples in which no virus was detected, the theoretical detection limits of the plaque assays equal to 3 PFU for MS2 per sample and 333 PFU for both FCV and MNV per sample were applied. In general, an increased time of exposure to steam-ultrasound correlated with an increased inactivation of virus.

The steam-ultrasound treatment was found to be very efficient for inactivation of viruses on plastic surfaces (Fig. 1A). Of the initial 8.85×10^9 PFU of MS2, an average reduction of 9.6 ± 0.4 log was observed after 1 s, while the initial 3.17×10^6 PFU of FCV and 2.67×10^6 PFU of MNV were reduced by $\geq 4.8 \pm 0.0$ log PFU and 3.71 ± 0.45 log PFU, respectively, after 3 s of treatment (Fig. 1A). The higher reduction in PFU per sample seen for

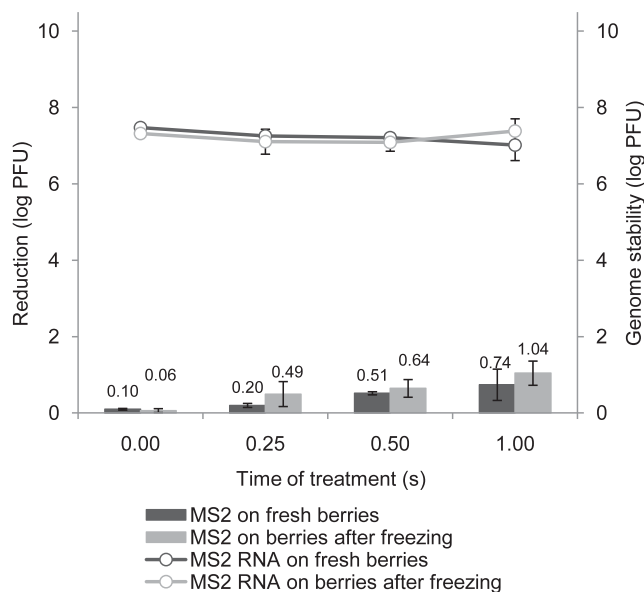

FIGURE 2. Inactivation by plaque assay (bars and etiquettes) and genome stability by real-time RT-PCR (curves) of MS2 inoculated on raspberries after steam-ultrasound treatment for various lengths of time.

MS2 cannot be directly compared with FCV and MNV because the initial virus titer, as well as the assay detection limit for MS2 compared with FCV and MNV, differed. However, assessing the efficiency of the treatment as percent inactivation showed fairly comparable effects of the treatment on MS2, FCV, and MNV, as an inactivation of >99.99% was found for MS2 and FCV after 1 or 3 s, respectively, and $99.97\% \pm 0.03\%$ for MNV after 3 s.

On raspberries, a reduction of infective MS2 of approximately 1 log ($\sim 89\%$) was observed for fresh raspberries that were stored frozen for 3 weeks after 1 s of steam-ultrasound treatment, while approximately 0.8-log ($\sim 77\%$) reduction was found for raspberries analyzed immediately after receiving the same exposure. However, this difference was found not to be statistically significant.

The reduced effect on MS2 infectivity on the surface of raspberries compared with petri dishes may be ascribed to the virus being protected in the depth of the pockets on the rough structure of the raspberry's surface. The steam-ultrasound method is known to have little effect on microorganisms in suspensions (23), in which the heat is likely prevented from rapidly reaching and destroying the surface of the microorganisms, e.g., the virus capsids. Although the inoculated raspberries were dried in a laminar flow hood prior to receiving treatment, some fluid that could shield the virus may have remained in the pockets, resulting in a reduced effect of the steam-ultrasound treatment. Hence, matrix-specific protective effects (e.g., petri dish or raspberries) and the conduct of the treatment process (presence of water condensed on raspberries while storing on ice before treatment) can affect the steam-ultrasound inactivation of virus. Indeed, matrix-derived protective effects have been described for different combinations of food commodities and viruses in connection with heat treatments (29, 40). For instance, spiced tomato sauce was

shown to provide protection against heat treatment of NoV (29), and increased fat content of milk appeared to provide increased heat stability of hepatitis A virus (40). In addition to the topological characteristics of the raspberry surface, the poor efficiency of the steam-ultrasound treatment after the short exposure time (1 s) may also contribute to the steam not being properly diffused over the entire raspberry surface. If this is the case, the location of the viruses would have an impact on the efficiency of the treatment.

It should be noted that approximately 10^{10} PFU was inoculated on 10-g portions of raspberries to ensure detectable results. However, contamination levels of this magnitude may be unlikely to be found in raspberries naturally contaminated with NoV.

Effect of the steam-ultrasound treatment on raspberries. Visual evaluation of raspberries 1 day after exposure to steam-ultrasound treatment for 0, 0.25, 0.5, and 1 s showed that 1 s of exposure resulted in raspberries that leaked fluid and had a fairly soft and sloppy texture compared with those not receiving any treatment or exposed for 0.25 and 0.5 s. Hence, further increase in treatment time to increase viral inactivation will probably not be possible with the current technology without significantly damaging the quality of the raspberries.

Stability of viral genomes after steam-ultrasound treatment. To test the stability of the viral genomes after receiving steam-ultrasound treatment, RT-qPCR was performed in duplicate on extracts from samples treated with steam-ultrasound on three different occasions.

For MS2, FCV, and MNV inoculated on plastic surfaces, similar genome copy numbers were found in the untreated controls and in samples treated for different lengths of time, as shown in Figure 1B for each of the three viruses. Despite a significant decrease in MS2 copies from 0 to 1 s of treatment, the copy numbers reached the level as obtained in the untreated samples after 3 s of treatment, and no significant reduction was found in the amounts of detected FCV or MNV RNA after 0.25 to 3 s of treatment. Likewise, no significant reduction was observed in genome levels of MS2 inoculated on raspberries after receiving increased treatment times (0 to 1 s) of steam-ultrasound, as indicated in Figure 2. The deficiency of RT-PCR detection to differentiate between infectious and noninfectious virus particles is, however, well known (8, 9). Heat treatment processes like steam-ultrasound may eliminate the infectivity of the viruses by altering or destroying their capsids (33), while still preserving RT-PCR detectable genomes. Indeed, Duizer et al. (15) have previously demonstrated that a reduction in FCV infectivity does not necessarily correlate with diminished ability to detect the viral genome. Using RT-PCR detection following heat treatment may therefore result in overestimating the amount of infectious viruses present in the sample, which seems to be the case in our study. Hence, existing RT-PCR methods cannot be used to evaluate whether a virus is inactivated by steam-ultrasound treatment. To solve this dilemma, new methods for detection of only infectious viruses have been proposed

(33, 35). One approach includes the use of proteinase K and/or RNase treatment prior to RNA extraction to cleave the capsids of noninfectious virus particles and, thereby, expose the genomic RNA for degradation by RNase. Another approach is the use of a DNA intercalating dye, propidium monoazide, which contains a photo-inducible azide group that covalently cross-links to DNA upon exposure to bright light (31). Studies of PCR in conjunction with propidium monoazide have been used to distinguish between viable and nonviable bacteria (31, 32, 34) and fungi (48) and, recently, infectious and noninfectious enteric RNA viruses (35).

Koopmans and Duizer (22) classified the risk of infection for the consumer as negligible, low, moderate, and high if the reduction of the virus titer is at least 4, 3, 2, or 1 log, respectively. Using this classification, our data suggest that steam-ultrasound could be a good decontamination method for surface areas (e.g., of utensils and plastic equipment), as 9.6-, 4.8-, or 3.7-log reductions were obtained for the NoV surrogates, MS2, FCV, and MNV, respectively. However, for reduction of the NoV surrogate MS2 on raspberry surfaces, steam-ultrasound treatment in its current format is not an appropriate method, since only a 1-log reduction could be achieved without damaging the quality of the raspberries. Therefore, further research into methods that simultaneously eliminate NoV from raspberries and other soft fruits and berries without damaging the texture of the produce is warranted to control future disease outbreaks associated with such produce contaminated with NoV.

In conclusion, our experiments reveal that the decrease in stability of viruses present on the surface of plastic during heat treatment by steam-ultrasound cannot be generalized to another product surface as shown here for raspberries, since there may be individual matrix-food-surface-specific protective effects that prevent virus inactivation. The steam-ultrasound treatment should be further tested for viral decontamination efficiency, using NoVs and other surface materials like steel commonly used in the food production industry as well as food products that are less fragile or that have smoother surfaces than raspberries.

ACKNOWLEDGMENTS

This work was supported by the Nordic Joint Committee for Agricultural Research (NKJ)-funded project "Reducing the risk from food-borne viruses in the Nordic countries" (acronym *FOOD-VIRUS*, contract no. NKJ 013-130) and by the Danish Veterinary and Food Administration. We thank Vice President Niels Krebs, SonoSteam A/S, Force technology, Denmark, for allowing us access to the steam-ultrasound apparatus, and Resadije Idrizi, the Technical University of Denmark, for excellent technical assistance.

REFERENCES

- Allwood, P. B., Y. S. Malik, C. W. Hedberg, and S. M. Goyal. 2004. Effect of temperature and sanitizers on the survival of feline calicivirus, *Escherichia coli*, and F-specific coliphage MS2 on leafy salad vegetables. *J. Food Prot.* 67:1451-1456.
- Anonymous. 1995. Water quality: detection and enumeration of bacteriophages, part 1. Enumeration of F-specific RNA bacteriophages. ISO 10705-1. International Organization for Standardization, Geneva.
- Anonymous. 2010. Annual report on zoonoses in Denmark 2009, National Food Institute, Technical University of Denmark, Søborg. Available at: www.dfvf.dk/Default.asp?ID=9606. Accessed 1 June 2010.
- Atmar, R. L., and M. K. Estes. 2006. The epidemiologic and clinical importance of norovirus infection. *Gastroenterol. Clin. N. Am.* 35: 275-90, viii.
- Baert, L., M. Uyttendaele, C. E. Van, and J. Debevere. 2008. The reduction of murine norovirus 1, *B. fragilis* HSP40 infecting phage B40-8 and *E. coli* after a mild thermal pasteurization process of raspberry puree. *Food Microbiol.* 25:871-874.
- Bidawid, S., N. Malik, O. Adegbonrin, S. A. Sattar, and J. M. Farber. 2003. A feline kidney cell line-based plaque assay for feline calicivirus, a surrogate for Norwalk virus. *J. Virol. Methods* 107: 163-167.
- Boysen, L., and H. Rosenquist. 2009. Reduction of thermotolerant *Campylobacter* species on broiler carcasses following physical decontamination at slaughter. *J. Food Prot.* 72:497-502.
- Butot, S., T. Putallaz, R. Amoroso, and G. Sánchez. 2009. Inactivation of enteric viruses in minimally processed berries and herbs. *Appl. Environ. Microbiol.* 75:4155-4161.
- Butot, S., T. Putallaz, and G. Sanchez. 2008. Effects of sanitation, freezing and frozen storage on enteric viruses in berries and herbs. *Int. J. Food Microbiol.* 126:30-35.
- Cannon, J. L., E. Papafragkou, G. W. Park, J. Osborne, L. A. Jaykus, and J. Vinje. 2006. Surrogates for the study of norovirus stability and inactivation in the environment: a comparison of murine norovirus and feline calicivirus. *J. Food Prot.* 69:2761-2765.
- Centers for Disease Control and Prevention. 2009. Surveillance for foodborne disease outbreaks—United States, 2006. *Morb. Mortal. Wkly. Rep.* 58:609-615.
- da Silva, A. K., J. C. Le Saux, S. Parnaudeau, M. Pommepey, M. Elimelech, and F. S. Le Guyader. 2007. Evaluation of removal of noroviruses during wastewater treatment, using real-time reverse transcription-PCR: different behaviors of genogroups I and II. *Appl. Environ. Microbiol.* 73:7891-7897.
- Dreier, J., M. Stormer, and K. Kleesiek. 2005. Use of bacteriophage MS2 as an internal control in viral reverse transcription-PCR assays. *J. Clin. Microbiol.* 43:4551-4557.
- Dubois, E., C. Hennechart, G. Merle, C. Burger, N. Hmila, S. Ruelle, S. Perelle, and V. Ferre. 2007. Detection and quantification by real-time RT-PCR of hepatitis A virus from inoculated tap waters, salad vegetables, and soft fruits: characterization of the method performances. *Int. J. Food Microbiol.* 117:141-149.
- Duizer, E., P. Bijkerk, B. Rockx, G. A. De, F. Twisk, and M. Koopmans. 2004. Inactivation of caliciviruses. *Appl. Environ. Microbiol.* 70:4538-4543.
- Falkenhorst, G., L. Krusell, M. Lisby, S. B. Madsen, B. Bottiger, and K. Molbak. 2005. Imported frozen raspberries cause a series of norovirus outbreaks in Denmark, 2005. *Euro Surveill.* 10:E050922.
- Glass, R. I., U. D. Parashar, and M. K. Estes. 2009. Norovirus gastroenteritis. *N. Engl. J. Med.* 361:1776-1785.
- Green, K. Y. 2007. *Caliciviridae: the noroviruses*, p. 949-979. In D. M. Knipe, P. M. Howley, D. E. Griffin, R. A. Lamb, M. A. Martin, B. Roizman, and S. E. Straus (ed.), *Fields virology*, 5th ed. Lippincott Williams and Wilkins, Philadelphia.
- Gulati, B. R., P. B. Allwood, C. W. Hedberg, and S. M. Goyal. 2001. Efficacy of commonly used disinfectants for the inactivation of calicivirus on strawberry, lettuce, and a food-contact surface. *J. Food Prot.* 64:1430-1434.
- Hjertqvist, M., A. Johansson, N. Svensson, P. E. Abom, C. Magnusson, M. Olsson, K. O. Hedlund, and Y. Andersson. 2006. Four outbreaks of norovirus gastroenteritis after consuming raspberries, Sweden, June-August 2006. *Euro Surveill.* 11:E060907.
- Kingsley, D. H., D. R. Holliman, K. R. Calci, H. Chen, and G. J. Flick. 2007. Inactivation of a norovirus by high-pressure processing. *Appl. Environ. Microbiol.* 73:581-585.
- Koopmans, M., and E. Duizer. 2004. Foodborne viruses: an emerging problem. *Int. J. Food Microbiol.* 90:23-41.
- Krebs, N. (SonoSteam A/S). 2010. Personal communication.

24. Le Guyader, F. S., C. Mittelholzer, L. Haugarreau, K. O. Hedlund, R. Alsterlund, M. Pommepuy, and L. Svensson. 2004. Detection of noroviruses in raspberries associated with a gastroenteritis outbreak. *Int. J. Food Microbiol.* 97:179–186.
25. Lowther, J. A., K. Henshilwood, and D. N. Lees. 2008. Determination of norovirus contamination in oysters from two commercial harvesting areas over an extended period, using semiquantitative real-time reverse transcription PCR. *J. Food Prot.* 71:1427–1433.
26. Lynch, M. F., R. V. Tauxe, and C. W. Hedberg. 2009. The growing burden of foodborne outbreaks due to contaminated fresh produce: risks and opportunities. *Epidemiol. Infect.* 137:307–315.
27. Maunula, L., M. Roivainen, M. Keranen, S. Makela, K. Soderberg, M. Summa, C. H. von Bonsdorff, M. Lappalainen, T. Korhonen, M. Kuusi, and T. Niskanen. 2009. Detection of human norovirus from frozen raspberries in a cluster of gastroenteritis outbreaks. *Euro Surveill.* 14:19435.
28. Morild, R. K., P. Christiansen, A. H. Sorensen, U. Nonboe, and S. Aabo. 2011. Inactivation of pathogens on pork by steam-ultrasound treatment. *J. Food Prot.* 74:769–775.
29. Mormann, S., M. Dabisch, and B. Becker. 2010. Effects of technological processes on the tenacity and inactivation of norovirus genogroup II in experimentally contaminated foods. *Appl. Environ. Microbiol.* 76:536–545.
30. Myrnel, M., E. M. Berg, B. Grinde, and E. Rimstad. 2006. Enteric viruses in inlet and outlet samples from sewage treatment plants. *J. Water Health* 4:197–209.
31. Nocker, A., C. Y. Cheung, and A. K. Camper. 2006. Comparison of propidium monoazide with ethidium monoazide for differentiation of live vs. dead bacteria by selective removal of DNA from dead cells. *J. Microbiol. Methods* 67:310–320.
32. Nocker, A., K. E. Sossa, and A. K. Camper. 2007. Molecular monitoring of disinfection efficacy using propidium monoazide in combination with quantitative PCR. *J. Microbiol. Methods* 70:252–260.
33. Nuanualsuwan, S., and D. O. Cliver. 2002. Pretreatment to avoid positive RT-PCR results with inactivated viruses. *J. Virol. Methods* 104:217–225.
34. Pan, Y., and F. Breidt, Jr. 2007. Enumeration of viable *Listeria monocytogenes* cells by real-time PCR with propidium monoazide and ethidium monoazide in the presence of dead cells. *Appl. Environ. Microbiol.* 73:8028–8031.
35. Parshionikar, S., I. Laseke, and G. S. Fout. 2010. Use of propidium monoazide in reverse transcriptase polymerase chain reactions to distinguish between infectious and non-infectious enteric viruses in water. *Appl. Environ. Microbiol.* 76:4318–4326.
36. Pebody, R. G., T. Leino, P. Ruutu, L. Kinnunen, I. Davidkin, H. Nohynek, and P. Leinikki. 1998. Foodborne outbreaks of hepatitis A in a low endemic country: an emerging problem? *Epidemiol. Infect.* 120:55–59.
37. Rawsthorne, H., T. G. Phister, and L. A. Jaykus. 2009. Development of a fluorescent in situ method for visualization of enteric viruses. *Appl. Environ. Microbiol.* 75:7822–7827.
38. Richards, G. P. 2001. Enteric virus contamination of foods through industrial practices: a primer on intervention strategies. *J. Ind. Microbiol. Biotechnol.* 27:117–125.
39. Rosenblum, L. S., I. R. Mirkin, D. T. Allen, S. Safford, and S. C. Hadler. 1990. A multifocal outbreak of hepatitis A traced to commercially distributed lettuce. *Am. J. Public Health* 80:1075–1079.
40. Sattar, S. A., T. Jason, S. Bidawid, and J. Farber. 2000. Foodborne spread of hepatitis A: recent studies on virus survival, transfer and inactivation. *Can. J. Infect. Dis.* 11:159–163.
41. SonoSteam. Force technology. Working principle: impact on surfaces. Available at: <http://www.sonosteam.com/cms/site.aspx?p=8559>. Accessed 1 May 2011.
42. Steele, M., and J. Odumeru. 2004. Irrigation water as source of foodborne pathogens on fruit and vegetables. *J. Food Prot.* 67:2839–2849.
43. Su, X., S. Zivanovic, and D. H. D'Souza. 2010. Inactivation of human enteric virus surrogates by high-intensity ultrasound. *Foodborne Pathog. Dis.* 7:1055–1061.
44. Teunis, P. F., C. L. Moe, P. Liu, E. Miller, L. Lindesmith, R. S. Baric, P. J. Le, and R. L. Calderon. 2008. Norwalk virus: how infectious is it? *J. Med. Virol.* 80:1468–1476.
45. Tierney, J. T., R. Sullivan, and E. P. Larkin. 1977. Persistence of poliovirus 1 in soil and on vegetables grown in soil previously flooded with inoculated sewage sludge or effluent. *Appl. Environ. Microbiol.* 33:109–113.
46. Topping, J. R., H. Schnerr, J. Haines, M. Scott, M. J. Carter, M. M. Willcocks, K. Bellamy, D. W. Brown, J. J. Gray, C. I. Gallimore, and A. I. Knight. 2009. Temperature inactivation of feline calicivirus vaccine strain FCV F-9 in comparison with human noroviruses using an RNA exposure assay and reverse transcribed quantitative real-time polymerase chain reaction—a novel method for predicting virus infectivity. *J. Virol. Methods* 156:89–95.
47. Venglovsky, J., J. Martinez, and I. Placha. 2006. Hygienic and ecological risks connected with utilization of animal manures and biosolids in agriculture. *Livestock Sci.* 102:197–203.
48. Vesper, S., C. McKinstry, C. Hartmann, M. Neace, S. Yoder, and A. Vesper. 2008. Quantifying fungal viability in air and water samples using quantitative PCR after treatment with propidium monoazide (PMA). *J. Microbiol. Methods* 72:180–184.

Chapter 11

Summarising discussion and perspectives

11 Summarising discussion and perspectives

In this chapter, the results from manuscripts I-V presented in this PhD-thesis will be discussed. This final discussion should be seen as a supplement to the individual discussions. Important findings are summarised and future directions, perspectives and concluding remarks are incorporated.

11.1 Virus recovery from food and drinking water

Outbreaks of gastroenteritis caused by the consumption of food and drinking water contaminated with enteric viruses, in particular NoV, are an increasing problem. Because only a few virus particles are enough to cause illness (Teunis et al., 2008) it is important to have rapid and efficient methods available to recover viruses that can be used for routine analysis and outbreak investigations from these matrices. Since NoV cannot be propagated in a cell culture, molecular methods such as RT-PCR are relied upon for detection. Therefore, it is imperative that such methods efficiently eliminate substances that are inhibitory to RT-PCR in the process.

Until now no standard harmonized procedures have been published for the recovery of non-cultivable enteric viruses from food and drinking water. In recent years, efforts have been made to identify and evaluate methods that could potentially function as a standard. For a method to become a standard it must be characterized according to a range of parameters including limit of detection, repeatability, limit of quantification, recovery efficiency, sensitivity, specificity, reproducibility (between laboratories), measurement uncertainties, and applicability (matrix) (Anon, 2003; Anon, 2009; Lees and CEN, 2010). As a contribution to the work done towards finding suitable standard methods for virus testing we evaluated the performance of methods for the recovery of NoV and other enteric viruses from shellfish (manuscript I) and drinking water (manuscript II) in relation to a selection of the parameters. In addition, we initiated an investigation into the feasibility of using a novel strategy, based on virus imprinted polymers (VIPs), to recover of NoVs from drinking water (manuscript III).

The ability of five methods to qualitatively recover NoV GII and FCV spiked in the digestive tissue of oysters and blue mussels were compared in manuscript I. A method based on a simple chopping followed by proteinase K digestion and RNA extraction using the semi-automated NucliSens kit followed by one-step real-time RT-PCR detection was found to give the best performance in regards to detection limit, repeatability, rapidity and simplicity. The method was

further evaluated in a collaborative trial with four participating laboratories for its ability to qualitatively recover NoV GI, NoV GII and HAV bioaccumulated in mussels and oysters. The method was easily implemented in the participating laboratories and could generally be used to robustly recover the NoV GI, NoV GII and HAV bioaccumulated in the both oysters and mussels. Consequently, we found the method to be a good candidate as a future qualitative standard for routine analysis of oysters and mussels for the presence of the most important viruses known to contaminate shellfish. This conclusion is further supported by the fact that the method in several cases has been used successfully for screening of NoV in oysters (Doré et al., 2010; Flannery et al., 2009) and has recently been used for quantitative recovery of NoV from oysters implicated in an outbreak of gastroenteritis at a restaurant in the UK (Baker et al., 2011). In fact, the method, which is similar to that developed by the European standardisation group (CEN/TC 275/WG6/TAG4) is currently in the final stage of being approved as an ISO standard and is expected to be published in 2012 (Lees and CEN, 2010).

In manuscript II we evaluated a rapid method's ability to recover NoV GI, NoV GII and AdV41 from Nordic drinking water (tap water) of various types. The method was based on filtering using a positively charged membrane followed by direct lysis of the virus adsorbed to the membrane. We found the method to be applicable on the 20 kinds of drinking water that were tested with 50% limits of detection similar to that found by Schultz et al. (2011a) using the same procedure to recover NoVs from bottled water. The average efficiency of the method to recover NoVs from drinking water was generally found to be better (Albinana-Gimenez et al., 2009; Gilgen et al., 1997; Karim et al., 2009; Lambertini et al., 2008; Victoria et al., 2009) or comparable (Haramoto et al., 2009) to previously described methods, suggesting that the method could be suitable for routine analysis. However, water type was found to significantly affect the recovery of all the tested virus types. As ionic strength (da Silva et al., 2011; Lance and Gerba, 1984), pH (Sobsey and Jones, 1979) and presence of organic components (Sobsey and Glass, 1984) have been reported to affect virus adsorption kinetics, we hypothesise that this difference is due to small variations in the composition of the drinking water. In concordance with other studies (Lambertini et al., 2008; Sobsey et al., 1981; Sobsey and Glass, 1984) our results also indicated that recovery was dependant on virus type. Consequently, the recovery efficiency of the method should, ideally, be checked for each water type and virus of interest.

As an alternative strategy for the recovery of NoVs from drinking water the feasibility of using VIPs for capture and selective recognition of NoVs was investigated in manuscript III.

Three VIPs targeted for MNV, NoV GI and NoV GII, respectively, were synthesised and experiments to determine binding suspensions of the target viruses and a non-target AdV strain to the VIPs and to non-imprinted polymers (NIPs) were conducted. Despite a higher percentage of binding was found for all VIPs compared with the NIPs, the difference in binding capacity was not significant, indicating that the virus binding may be a result of unspecific binding rather than binding via specific recognition. Unspecific binding is, indeed, a well known problem that can be caused by an excess amount of monomer used for production of polymer (Zhang et al., 2010). In addition, a high degree of unspecific binding to the VIPs was observed as no significant differences between binding of target NoVs and the non-target AdV strain were found. We hypothesise that the poor selective recognition and unspecific binding observed, in addition to an excess amount of monomers, may be attributed to factors such as saturation of low abundant binding sites in the polymer, virus aggregation, insufficient virus removal hindering rebinding, binding results not being correlated to the polymer mass, and swelling of the polymer. Excess swelling of polymers in water, resulting in cavities too large to selectively bind a target virus has for instance been reported previously (Bolisay and Kofinas, 2010). Based on the results achieved in manuscript III virus imprinting in its current form does not seem to be a feasible approach for selective recovery of NoV from drinking water and can at present not compete with the filter-based method described in manuscript II. Nevertheless, with further development and optimisation VIPs could have a potential as a means to selectively recover NoVs from drinking water. Numerous other studies have previously demonstrated that imprinted polymers coupled to a sensor systems can be used for detection of environmental contaminants (Alizadeh et al., 2012; Birnbaumer et al., 2009; Hayden et al., 2006). The possibility of coupling VIPs with a sensor is a particular intriguing future aspect of virus imprinting as it could enable on-line monitoring for NoV in drinking water at waterworks.

For any standardised method, inclusion of a process control that monitors the sample treatment process is a prerequisite in order to verify that the sample treatment has functioned correctly, and to identify samples in which the sample treatment has failed (Baert et al., 2011; Diez-Valcarce et al., 2011a). MC₀ was used as a process control in the method evaluation studies performed on shellfish (manuscript I) and drinking water (manuscript II). In addition MC₀ was used as a process control to monitor the success of virus recovery from air (dust filters) and wastewater in manuscript IV. MC₀ was selected as a process control due to its similarities in structural characteristics and behaviour with the target viruses. Moreover, it is non-pathogenic to humans, can easily be cultivated and is not believed to be naturally present in the tested matrices (Costafreda et

al., 2006; Le Guyader et al., 2009). The value of vMC_0 as a process control was clearly demonstrated in manuscript I where a poor recovery of vMC_0 was found to correlate with a poor recovery of NoV GI.3b, NoV GII.4 and HAV in specific samples. Moreover, as demonstrated in manuscripts I, II and IV, MC_0 can be used to determine the efficiency of a method to recover viruses. Such information is useful for comparison and harmonization of data between laboratories. Finally, the recovery efficiency of MC_0 may also be used to correct the number of virus genomic copies present in a naturally contaminated samples as it has recently been demonstrated in shellfish studies (Le Guyader et al., 2004a; Pinto et al., 2009). When using the recovery efficiency for MC_0 for such an application one should take in to consideration that the recovery of MC_0 may not always directly reflect the recovery of enteric viruses present in naturally contaminated samples. We, for instance, saw indications of MC_0 not being completely stable under the conditions used during recovery from shellfish in manuscript I. Our observation was in agreement with Comelli et al. (2008), which found spiked MC_0 to be less stable than spiked NoV during recovery from shellfish tissue.

11.2 Exposure to airborne noroviruses

Based on epidemiological information from outbreaks, the transmission of NoV through aerosol formation, especially following vomiting, has been suggested (Marks et al., 2000; Marks et al., 2003). However, unlike foodborne and waterborne transmission, little is known regarding the significance of airborne transmission of NoV. Until now, qualitative detection of NoV genomes in air downwind from a biosolid land application site (Brooks et al., 2005) and on horizontal surfaces above normal reach (>1.5 m) in a hotel during a NoV outbreak (Cheesbrough et al., 2000) has been the only direct evidence indicating that aerosolisation and air dispersal of NoV takes place.

To contribute with a new understanding of the extent of airborne transmission of NoV and other enteric viruses we investigated the exposure to airborne NoVs and Adv40/41 at a Danish WWTP in manuscript IV. NoV GI was detected on the personal dust filter carried by one out of four workers in a concentration above the oral infective dose (ID_{50}) of 18 viral particles determined by Teunis et al. (2008). This finding could explain the high frequency of acute symptoms in gastrointestinal tract, consistent with a NoV infection, which had been reported among the workers at the WWTP. Consequently, we hypothesise that airborne transmission of NoVs do indeed occur, and that exposure to aerosolised NoVs may pose an occupational health risk. However, as the

evidence obtained in the study is only circumstantial and limited by the low number of samples, a more elaborate study should be conducted in the future to definitively connect exposure to aerosolised NoVs with NoV infections in humans. The study also revealed a positive correlation between exposure to endotoxin, mould, bacteria and virus suggesting that exposure to NoVs at the WWTP may be related to specific work tasks and the proximity to the source. To enable implementation of targeted control strategies that can minimise occupational exposure, future effort should go into identifying the source of the contamination at the WWTP and level of NoV dispersal. Moreover, the influence of factors, such as seasonality, meteorological conditions and type and capacity of treatment facility on the aerosol exposure should be examined.

In manuscript IV sampling of the viral aerosols was carried out using personal samplers containing polycarbonate filters with a pore size of 1 µm. Viruses were recovered from the filters using an identical approach to that used to recover viruses from drinking water in manuscript II. Although the air sampling strategy employed in manuscript IV appears to be applicable, optimisation of the method with regards to the selection of sampler, filter and pore type should be performed to maximise virus recovery. Gelatin and PTFE filters have, for instance, been reported to have higher collection efficiencies for MS2 than polycarbonate filters (Burton et al., 2007). Thus, similar collection properties of the filters might exist for NoV.

11.3 Norovirus decontamination

To prevent foodborne NoV outbreaks, suitable decontamination strategies that permit effective inactivation of NoV without affecting food quality are required, especially for the foods such as fresh produce that are often associated with NoV outbreaks. High temperature heat treatments e.g. boiling for 1 min and thermal sterilisation (121°C for 15 min), are believed to inactivate NoV effectively. However, such treatments will result in adverse changes in sensory and textural attributes of these food commodities. To minimize negative impact of the heat treatment, we investigated the potential of using a new surfaces decontamination technique that combines pressurised steam and high-power ultrasound to give an enhanced effect of the steam, thereby substantially reducing the thermal exposure time necessary to inactivate NoV.

Using MS2, FCV and MNV as NoV surrogates steam-ultrasound treatment was found to be efficient for decontamination of smooth surface areas as near complete inactivation was achieved after treatment for 1 s for MS2 and 3 s for both FCV and MNV. However, only a 1-log

reduction of MS2 could be achieved on raspberry surfaces at which point a loss of texture was evident. This is comparable to the effect reported for treatments with 40 mW s/cm² UV light for reduction of FCV on strawberries (Fino and Kniel, 2008), 40 kGY gamma irradiation for reduction of MNV on spinach, lettuce and strawberries (Feng et al., 2011), washing with 200 ppm sodium hypochlorite for reduction of MNV on lettuce (Baert et al., 2009a), and washing with 150 ppm peroxyacetic acid for reduction of MNV on strawberries (Gulati et al., 2001). Nonetheless, such a reduction is insufficient to considerably reduce the risk of foodborne related NoV outbreaks. Because the treatment time cannot be increased without destruction of the raspberry quality, steam-ultrasound treatment in its current form does not appear to be an appropriate method for decontamination of NoV on raspberries and other likewise fragile berry types. Hence, other strategies for decontamination of like products should be exploited.

Strategies based on chemical washing are generally not well accepted by the consumer and therefore may not be a viable treatment form for NoV inactivation. Furthermore, as chemical washing so far only has been found to result in a marginal reduction of viruses on fresh produce, high concentrations will likely be required to achieve adequate viral reduction. This will limit the applicability of this type of treatment due to sensorial changes and toxicological aspects. The use of irradiation may also be problematic due to legislative restrictions. Gamma irradiation on food commodities other than herbs are for instance not allowed in Denmark (Anon, 2000) and in countries such as the US (Anon, 1999), where gamma irradiation can be employed, the maximum allowed dose will most likely not result in adequate NoV inactivation. The use of HHP treatment for NoV decontamination may, however, have potential as it has been reported to result in less severe changes in the food quality than thermal treatment and has been found to result in more plausible reductions of NoV surrogates in food under certain conditions. Thus, the prospect of using HHP for decontamination of food should be further elucidated in the future.

11.4 Concluding remarks

This thesis has contributed to the work done towards finding standardised methods suitable for routine testing and outbreak investigations of non-cultivable enteric viruses by providing valuable data on the performance of various methods for recovery of NoV from both shellfish and drinking water. Furthermore, the thesis has contributed with new knowledge on the transmission route of NoV by being the first to demonstrate occupational exposure to airborne NoV through its detection

and quantification on WWTP workers' dust filters. Finally, the thesis has elucidated the possibility of using steam-ultrasound in hopes of finding a way to reduce the substantial number of foodborne-related NoV outbreaks occurring worldwide. Although, the treatment was found to be inappropriate for NoV decontamination of raspberries, the obtained results will help direct future research in the area.

Chapter 12

References

12 References

- Anon., 1999. U.S. FDA. Irradiation in the production, processing and handling of food. Ionizing radiation for the treatment of food. Code of Federal Regulations 21CFR179.26.
- Anon., 2000. Bekendtgørelse om fremstilling, markedsføring og indførelse af fødevarer og fødevaringredienser, der er behandlet med ioniserende stråling. BEK nr. 796 af 22/08/2000.
- Anon., 2002. Opinion of the scientific committee on veterinary measures relating to public health on Norwalk-like viruses. European Commission, Health & Consumer Protection Directorate-General, Directorate-Scientific Opinions, C2.
- Anon., 2003. ISO16140:2003. Microbiology of food and animal feeding stuffs - protocol for the validation of alternative methods.
- Anon., 2009. NordVal protocol for the validation of alternative microbiological methods.
- Anon., 2011a. Annual Report on Zoonoses in Denmark 2010. National Food Institute, Technical University of Denmark.
- Anon., 2011b. Fakta om norovirus. The Danish Veterinary and Food Administration, Ministry of Food, Agriculture and Fisheries.
http://www.foedevarestyrelsen.dk/Foedevarer/Bakterier_og_virus/Norovirus/Sider/forside.aspx.
- Albinana-Gimenez,N., Clemente-Casares,P., Calgua,B., Huguet,J.M., Courtois,S., Girones,R., 2009. Comparison of methods for concentrating human adenoviruses, polyomavirus JC and noroviruses in source waters and drinking water using quantitative PCR. *J. Virol. Methods.* 158, 104-109.
- Alizadeh,T., Ganjali,M.R., Zare,M., Norouzi,P., 2012. Selective determination of chloramphenicol at trace level in milk samples by the electrode modified with molecularly imprinted polymer. *Food Chem.* 130, 1108-1114.
- Arnal,C., Ferré-Aubineau,V., Besse,B., Mignotte,B., Schwartzbrod,L., Billaudel,S., 1999. Comparison of seven RNA extraction methods on stool and shellfish samples prior to hepatitis A virus amplification. *J. Virol. Methods.* 77, 17-26.
- Asanaka,M., Atmar,R.L., Ruvolo,V., Crawford,S.E., Neill,F.H., Estes,M.K., 2005. Replication and packaging of Norwalk virus RNA in cultured mammalian cells. *Proceedings of the National Academy of Sciences of the United States of America.* 102, 10327-10332.
- Atha,D.H., Ingham,K.C., 1981. Mechanism of precipitation of proteins by polyethylene glycols - analysis in terms of excluded volume. *J. Biol. Chem.* 256, 2108-2117.
- Atmar,R.L., Metcalf,T.G., Neill,F.H., Estes,M.K., 1993. Detection of enteric viruses in oysters by using the polymerase chain reaction. *Appl. Environ. Microbiol.* 59, 631-635.
- Atmar,R.L., Neill,F.H., Romalde,J.L., Guyader,F.I., Woodley,C.M., Metcalf,T.G., Estes,M.K., 1995. Detection of Norwalk virus and hepatitis A virus in shellfish tissues with the PCR. *Appl. Environ. Microbiol.* 61, 3014-3018.

- Atmar,R.L., 2010. Noroviruses: State of the art. *Food Environ. Virol.* 2, 117-126.
- Atmar,R.L., Estes,M.K., 2001. Diagnosis of noncultivable gastroenteritis viruses, the human caliciviruses. *Clin. Microbiol. Rev.* 14, 15-37.
- Atmar,R.L., Opekun,A.R., Gilger,M.A., Estes,M.K., Crawford,S.E., Neill,F.H., Graham,D.Y., 2008. Norwalk virus shedding after experimental human infection. *Emerging Infect. Dis.* 14, 1553-1557.
- Ausar,S.F., Middaugh,C.R., Foubert,T.R., Hudson,M.H., Vedvick,T.S., Middaugh,C.R., 2006. Conformational stability and disassembly of norwalk virus-like particles: Effect of pH and temperature. *J. Biol. Chem.* 281, 19478-19488.
- Baert,L., Debevere,J., Uyttendaele,M., 2009a. The efficacy of preservation methods to inactivate foodborne viruses. *Int. J. Food Microbiol.* 131, 83-94.
- Baert,L., Mattison,K., Loisy-Hamon,F., Harlow,J., Martyres,A., Lebeau,B., Stals,A., van Coillie,E., Herman,L., Uyttendaele,M., 2011. Review: Norovirus prevalence in Belgian, Canadian and French fresh produce: A threat to human health? *Int. J. Food Microbiol.* 151, 261-269.
- Baert,L., Uyttendaele,M., Debevere,J., 2007. Evaluation of two viral extraction methods for the detection of human noroviruses in shellfish with conventional and real-time reverse transcriptase PCR. *Lett. Appl. Microbiol.* 44, 106-111.
- Baert,L., Uyttendaele,M., van Coillie,E., Debevere,J., 2008a. The reduction of murine norovirus 1, *B. fragilis* HSP40 infecting phage B40-8 and *E. coli* after a mild thermal pasteurization process of raspberry puree. *Food Microbiol.* 25, 871-874.
- Baert,L., Uyttendaele,M., Vermeersch,M., van Coillie,E., Debevere,J., 2008b. Survival and transfer of murine norovirus 1, a surrogate for human noroviruses, during the production process of deep-frozen onions and spinach. *J. Food Protect.* 71, 1590-1597.
- Baert,L., Vandekinderen,I., Devlieghere,F., van Coillie,E., Debevere,J., Uyttendaele,M., 2009b. Efficacy of sodium hypochlorite and peroxyacetic acid to reduce murine norovirus 1, B40-8, *Listeria monocytogenes*, and *Escherichia coli* O157:H7 on shredded iceberg lettuce and in residual wash water. *J. Food Protect.* 72, 1047-1054.
- Baert,L., Wobus,C.E., van Coillie,E., Thackray,L.B., Debevere,J., Uyttendaele,M., 2008c. Detection of murine norovirus 1 by using plaque assay, transfection assay, and real-time reverse transcription-PCR before and after heat exposure. *Appl. Environ. Microbiol.* 74, 543-546.
- Baker,K., Morris,J., McCarthy,N., Saldana,L., Lowther,J., Collinson,A., Young,M., 2011. An outbreak of norovirus infection linked to oyster consumption at a UK restaurant, February 2010. *J. Public Health.* 33, 205-211.
- Belliot,G., Sosnovtsev,S.V., Chang,K.O., Babu,V., Uche,U., Arnold,J.J., Cameron,C.E., Green,K.Y., 2005. Norovirus proteinase-polymerase and polymerase are both active forms of RNA-dependent RNA polymerase. *J. Virol.* 79, 2393-2403.

- Bertolotti-Ciarlet,A., Crawford,S.E., Hutson,A.M., Estes,M.K., 2003. The 3' end of Norwalk virus mRNA contains determinants that regulate the expression and stability of the viral capsid protein VP1: A novel function for the VP2 protein. *J. Virol.* 77, 11603-11615.
- Bertolotti-Ciarlet,A., White,L.J., Chen,R., Prasad,B.V.V., Estes,M.K., 2002. Structural requirements for the assembly of Norwalk virus-like particles. *J. Virol.* 76, 4044-4055.
- Beuret,C., Baumgartner,A., Schluup,J., 2003. Virus-contaminated oysters: A three-month monitoring of oysters imported to Switzerland. *Appl. Environ. Microbiol.* 69, 2292-2297.
- Birnbaumer,G.M., Lieberzeit,P.A., Richter,L., Schirhagl,R., Milnera,M., Dickert,F.L., Bailey,A., Ertl,P., 2009. Detection of viruses with molecularly imprinted polymers integrated on a microfluidic biochip using contact-less dielectric microsensors. *Lab Chip.* 9, 3549-3556.
- Block,J.C., Schwartzbrod,L., 1989. Viruses in water systems. Detection and identification.
- Bofill-Mas,S., binana-Gimenez,N., Clemente-Casares,P., Hundesa,A., Rodriguez-Manzano,J., Girones,R., Calvo,M., Allard,A., 2006. Quantification and stability of human adenoviruses and polyomavirus JCPyV in wastewater matrices. *Appl. Environ. Microbiol.* 72, 7894-7896.
- Bolisay,L.D., Kofinas,P., 2010. Imprinted polymer hydrogels for the separation of viruses. *Macromol. Symp. (Germany).* 291-292, 302-306.
- Boom,Rx., Sol,Cx.J.A., Salimans,M.M.M., Jansen,C.L., Wertheim-van Dillen,P.M.E., van der Noordaa,J., 1990. Rapid and simple method for purification of nucleic acids. *J. Clin. Microbiol.* 28, 495-503.
- Borchardt,M.A., Bradbury,K.R., Alexander,E.C., Alexander,S.C., Kolberg,R.J., Archer,J.R., Braatz,L.A., Forest,B.M., Green,J.A., Spencer,S.K., 2011. Norovirus Outbreak Caused by a New Septic System in a Dolomite Aquifer 84. *Ground Water.* 49, 85-97.
- Bosch,A., Guix,S., Sano,D., Pinto,R.M., 2008. New tools for the study and direct surveillance of viral pathogens in water. *Curr. Opin. Biotechnol.* 19, 295-301.
- Bosch,A., Sanchez,G., Abbaszadegan,M., Carducci,A., Guix,S., Le Guyader,F.S., Netshikweta,R., Pinto,R.M., Poel,W.H.M., Rutjes,S., Sano,D., Taylor,M.B., van Zyl,W.B., Rodríguez-Lázaro,D., Kovac,K., Sellwood,J., 2011. Analytical methods for virus detection in water and food. *Food Anal. Methods.* 4, 4-12.
- Boxman,I.L.A., Tilburg,J.J.H.C., te Loeke,N.A.J.M., Vennema,H., Jonker,K., de Boer,E., Koopmans,M., 2006. Detection of noroviruses in shellfish in the Netherlands. *Int. J. Food Microbiol.* 108, 391-396.
- Brooks,J.P., Tanner,B.D., Josephson,K.L., Gerba,C.P., Haas,C.N., Pepper,I.L., 2005. A national study on the residential impact of biological aerosols from the land application of biosolids. *J. Appl. Microbiol.* 99, 310-322.

- Buckow,R., Knorr,D., Heinz,V., Isbarn,S., Lehmacher,A., 2008. Predictive model for inactivation of feline calicivirus, a norovirus surrogate, by heat and high hydrostatic pressure. *Appl. Environ. Microbiol.* 74, 1030-1038.
- Burton,N.C., Grinshpun,S.A., Reponen,T.I.I.N., 2007. Physical collection efficiency of filter materials for bacteria and viruses. *Ann. Occup. Health.* 51, 143-151.
- Butot,S., Putallaz,T., Amoroso,R., Sanchez,G., 2009. Inactivation of enteric viruses in minimally processed berries and herbs. *Appl. Environ. Microbiol.* 75, 4155-4161.
- Butot,S., Putallaz,T., Sanchez,G., 2007. Procedure for rapid concentration and detection of enteric viruses from berries and vegetables. *Appl. Environ. Microbiol.* 73, 186-192.
- Butot,S., Le Guyader,F.S., Krol,J., Putallaz,T., Amoroso,R., Sanchez,G., 2010. Evaluation of various real-time RT-PCR assays for the detection and quantitation of human norovirus. *J. Virol. Methods.* 167, 90-94.
- Cannon,J.L., Papafragkou,E., Geunwoo,W.P., Osborne,J., Jaykus,L.A., Vinje,J., 2006. Surrogates for the study of norovirus stability and inactivation in the environment: a comparison of murine norovirus and feline calicivirus. *J. Food Protect.* 69, 2761-2765.
- Carducci,A., Arrighi,S., Ruschi,A., 1995. Detection of coliphages and enteroviruses in sewage and aerosol from an activated sludge wastewater treatment plant. *Lett. Appl. Microbiol.* 21, 207-209.
- Carducci,A., Tozzi,E., Rubulotta,E., Casini,B., Cantiani,L., Rovini,E., Muscillo,M., Pacini,R., 2000. Assessing airborne biological hazard from urban wastewater treatment. *Water Res.* 34, 1173-1178.
- Carlsson,B., Kindberg,E., Buesa,J., Rydell,G.E., Lidón,M.F., Montava,R., Abu Mallouh,R., Grahn,A., Rodriguez-Manzano,J., Bellido,J., Arnedo,A., Larson,G., Svensson,L., 2009. The G428A nonsense mutation in FUT2 provides strong but not absolute protection against symptomatic GII.4 Norovirus infection. *PLoS One.* 4, e5593.
- Carrique-Mas,J., Andersson,Y., Petersen,B., Hedlund,K.O., Sjogren,N., Giesecke,J., 2003. A Norwalk-like virus waterborne community outbreak in a Swedish village during peak holiday season
87. *Epidemiol. Infect.* 131, 737-744.
- Cheesbrough,J.S., Green,J., Gallimore,C.I., Wright,P.A., Brown,D.W.G., 2000. Widespread environmental contamination with Norwalk-like viruses (NLV) detected in a prolonged hotel outbreak of gastroenteritis. *Epidemiol. Infect.* 125, 93-98.
- Cheetham,S., Souza,M., Meulia,T., Grimes,S., Han,M.G., Saif,L.J., 2006. Pathogenesis of a genogroup II human norovirus in gnotobiotic pigs. *J. Virol.* 80, 10372-10381.
- Chen,H., Hoover,D.G., Kingsley,D.H., 2005. Temperature and treatment time influence high hydrostatic pressure inactivation of feline calicivirus, a norovirus surrogate. *J. Food Protect.* 68, 2389-2394.

- Chironna, M., Germinario, C., Medici, D.d., Fiore, A., Pasquale, S.d., Quarto, M., Barbuti, S., 2002. Detection of hepatitis A virus in mussels from different sources marketed in Puglia region (South Italy). *Int. J. Food Microbiol.* 75, 11-18.
- Comelli, H.L., Rimstad, E., Larsen, S., Myrmel, M., 2008. Detection of norovirus genotype I.3b and II.4 in bioaccumulated blue mussels using different virus recovery methods. *Int. J. Food Microbiol.* 127, 53-59.
- Costafreda, M.I., Bosch, A., Rosa, M., 2006. Development, evaluation, and standardization of a real-time TaqMan reverse transcription-PCR assay for quantification of hepatitis A virus in clinical and shellfish samples. *Appl. Environ. Microbiol.* 72, 3846-3855.
- Costantini, V., Grenz, L., Fritzinger, A., Lewis, D., Biggs, C., Hale, A., Vinje, J., 2010. Diagnostic accuracy and analytical sensitivity of ideia norovirus assay for routine screening of human norovirus. *J. Clin. Microbiol.* 48, 2770-2778.
- Croci, L., De Medici, D., Scalfaro, C., Fiore, A., Divizia, M., Donia, D., Cosentino, A.M., Moretti, P., Costantini, G., 2000. Determination of enteroviruses, hepatitis A virus, bacteriophages and *Escherichia coli* in Adriatic Sea mussels. *J. Appl. Microbiol.* 88, 293-298.
- Croci, L., Suffredini, E., Di Pasquale, S., Cozzi, L., 2012. Detection of norovirus and feline calicivirus in spiked molluscs subjected to heat treatments. *Food Control.* 25, 17-22.
- D'Agostino, M., Cook, N., Rodriguez-Lazaro, D., Rutjes, S., 2011. Nucleic acid amplification-based methods for detection of enteric viruses: Definition of controls and interpretation of results. *Food Environ. Virol.* 3, 55-60.
- D'Souza, D.H., Sair, A., Williams, K., Papafragkou, E., Jean, J., Moore, C., Jaykus, L., 2006. Persistence of caliciviruses on environmental surfaces and their transfer to food. *Int. J. Food Microbiol.* 108, 84-91.
- da Silva, A.K., Elimelech, M., Le Saux, J.C., Parnaudeau, S., Pommepuy, M., Le Guyader, F.S., 2007. Evaluation of removal of noroviruses during wastewater treatment, using real-time reverse transcription-PCR: Different behaviors of genogroups I and II. *Appl. Environ. Microbiol.* 73, 7891-7897.
- da Silva, A.K., Kavanagh, O.V., Estes, M.K., Elimelech, M., 2011. Adsorption and aggregation properties of norovirus GI and GII virus-like particles demonstrate differing responses to solution chemistry. *Environ. Sci. Technol.* 45, 520-526.
- Daughenbaugh, K.F., Fraser, C.S., Hershey, J.W.B., Hardy, M.E., 2003. The genome-linked protein VPg of the Norwalk virus binds eIF3, suggesting its role in translation initiation complex recruitment. *EMBO J.* 22, 2852-2859.
- Daughenbaugh, K.F., Wobus, C.E., Hardy, M.E., 2006. VPg of murine norovirus binds translation initiation factors in infected cells. *Virol. J.* 3.
- David, S.T., McIntyre, L., MacDougall, L., Kelly, D., Liem, S., Schallié, K., McNabb, A., Houde, A., Mueller, P., Ward, P., Trottier, Y.L., Brassard, J., 2007. An Outbreak of Norovirus Caused by

- Consumption of Oysters from Geographically Dispersed Harvest Sites, British Columbia, Canada, 2004. *Foodborne Pathog. Dis.* 4, 349-358.
- Dawson,D.J., Paish,A., Staffell,L.M., Seymour,I.J., Appleton,H., 2005. Survival of viruses on fresh produce, using MS2 as a surrogate for norovirus. *J. Appl. Microbiol.* 98, 203-209.
- De Jong,J.C., Harmsen,M., Trouwborst,T., 1973. The infectivity of the nucleic acid of aerosol-inactivated poliovirus. *J. Gen. Virol.* 18, 83-86.
- de Roda Husman,A.M., Lodder-Verschuur,F., van den Berg,H.H.J.L., Guyader,F.S., van Pelt,H., van der Poel,W.H.M., Rutjes,S.A., 2007. Rapid virus detection procedure for molecular tracing of shellfish associated with disease outbreaks. *J. Food Protect.* 70, 967-974.
- De Roda Husman,A.M., Lodder,W., Van Den Berg,H., Bijkerk,P., Duizer,E., Pribil,W., Sommer,R., Cabaj,A., Gehringer,P., 2004. Calicivirus inactivation by nonionizing (253.7-nanometer-wavelength [UV]) and ionizing (gamma) radiation. *Appl. Environ. Microbiol.* 70, 5089-5093.
- Di Pasquale,S., Paniconi,M., Auricchio,B., Orefice,L., Schultz,A.C., De Medici,D., 2010. Comparison of different concentration methods for the detection of hepatitis A virus and calicivirus from bottled natural mineral waters. *J. Virol. Methods.* 165, 57-63.
- Diez-Valcarce,M., Cook,N., Hernández,M., Rodríguez-Lázaro,D., 2011a. Analytical application of a sample process control in detection of foodborne viruses. *Food Anal. Methods.* 4, 614-618.
- Diez-Valcarce,M., Kovac,K., Cook,N., Rodriguez-Lazaro,D., Hernández,M., 2011b. Construction and analytical application of internal amplification controls (IAC) for detection of food supply chain-relevant viruses by real-time PCR-based assays. *Food Anal. Methods.* 4, 437-445.
- Donaldson,E.F., Lindesmith,L.C., Lobue,A.D., Baric,R.S., 2008. Norovirus pathogenesis: mechanisms of persistence and immune evasion in human populations. *Immunol. Rev.* 225, 190-211.
- Donaldson,E.F., Lindesmith,L.C., Lobue,A.D., Baric,R.S., 2010. Viral shape-shifting: norovirus evasion of the human immune system. *Nat. Rev. Microbiol.* 8, 231-241.
- Doré,Bx., Keaveney,S., Flannery,J., Rajko-Nenow,P., 2010. Management of health risks associated with oysters harvested from a norovirus contaminated area, Ireland, February-March 2010. *Euro surveillance.* 15. <http://www.eurosurveillance.org/ViewArticle.aspx?ArticleId=19567> .
- Dore,W.J., Henshilwood,K., Lees,D.N., 2000. Evaluation of F-specific RNA bacteriophage as a candidate human enteric virus indicator for bivalve molluscan shellfish. *Appl. Environ. Microbiol.* 66, 1280-1285.
- Doultree,J.C., Druce,J.D., Birch,C.J., Bowden,D.S., Marshall,J.A., 1999. Inactivation of feline calicivirus, a Norwalk virus surrogate. *J. Hosp. Infect.* 41, 51-57.
- Dreier,J., Stoermer,M., Maede,D., Burkhardt,S., Kleesiek,K., 2006. Enhanced reverse transcription-PCR assay for detection of norovirus genogroup I. *J. Clin. Microbiol.* 44, 2714-2720.

- Dubois,E., Agier,C., Traore,O., Hennechart,C., Merle,G., Cruciere,C., Laveran,H., 2002. Modified concentration method for the detection of enteric viruses on fruits and vegetables by reverse transcriptase-polymerase chain reaction or cell culture. *J. Food Protect.* 65, 1962-1969.
- Dubois,E., Hennechart,C., Merle,G., Burger,C., Hmila,N., Ruelle,S., Perelle,S., Ferre,V., 2007. Detection and quantification by real-time RT-PCR of hepatitis A virus from inoculated tap waters, salad vegetables, and soft fruits: Characterization of the method performances. *Int. J. Food Microbiol.* 117, 141-149.
- Duizer,E., Bijkerk,P., Rockx,B., De Groot,A., Twisk,F., Koopmans,M., Duizer,E., 2004. Inactivation of caliciviruses. *Appl. Environ. Microbiol.* 70, 4538-4543.
- EFSA Panel on Biological Hazards (BIOHAZ), 2011. Scientific Opinion on an update on the present knowledge on the occurrence and control of foodborne viruses. *EFSA Journal.* 9.
- Ethelberg,S., Lisby,M., Bottiger,B., Schultz,A.C., Villif,A., Jensen,T., Olsen,K.E., Scheutz,F., Kjelson,C., Muller,L., 2010. Outbreaks of gastroenteritis linked to lettuce, Denmark, January 2010. *Euro surveillance.* 15.
- Ettayebi,K., Hardy,M.E., 2003. Norwalk virus nonstructural protein p48 forms a complex with the SNARE regulator VAP-A and prevents cell surface expression of vesicular stomatitis virus G protein. *J. Virol.* 77, 11790-11797.
- Fahie-Wilson,M., Halsall,D., 2008. Polyethylene glycol precipitation: proceed with care. *Ann. Clin. Biochem.* 45, 233-235.
- Falkenhorst,G., Krusell,L., Lisby,M., Madsen,S.B., Böttiger,B., Mølbak,K., 2005. Imported frozen raspberries cause a series of norovirus outbreaks in Denmark, 2005. *Euro Surveill.* 10. <http://www.eurosurveillance.org/ViewArticle.aspx?ArticleId=2795>.
- Fankhauser,R.L., Monroe,S.S., Noel,J.S., Humphrey,C.D., Bresee,J.S., Parashar,U.D., Ando,T., Glass,R.I., 2002. Epidemiologic and molecular trends of "Norwalk-like viruses" associated with outbreaks of gastroenteritis in the United States. *J. Infect. Dis.* 186, 1-7.
- Fannin,K.F., Vana,S.C., Jakubowski,W., 1985. Effect of an activated sludge wastewater treatment plant on ambient air densities of aerosols containing bacteria and viruses. *Appl. Environ. Microbiol.* 49, 1191-1196.
- Farrah,S.R., Gerba,C.P., Wallis,C., Melnick,J.L., 1976. Concentration of viruses from large volumes of tap water using pleated membrane filters. *Appl. Environ. Microbiol.* 31, 221-226.
- Fattal,B., Katzenelson,E., 1976. Evaluation of gauze pad method to recover viruses from water. *Water Res.* 10, 1135-1140.
- Feng,K., Divers,E., Ma,Y., Li,J., 2011. Inactivation of a human norovirus surrogate, human norovirus virus-like particles, and vesicular stomatitis virus by Gamma irradiation. *Appl. Environ. Microbiol.* 77, 3507-3517.

- Fernandez-Vega, V., Sosnovtsev, S.V., Belliot, G., King, A.D., Mitra, T., Gorbalenya, A., Green, K.Y., 2004. Norwalk virus N-terminal nonstructural protein is associated with disassembly of the Golgi complex in transfected cells. *J. Virol.* 78, 4827-4837.
- Fino, V.R., Kniel, K.E., 2008. UV light inactivation of hepatitis A virus, Aichi virus, and feline calicivirus on strawberries, green onions, and lettuce. *J. Food Protect.* 71, 908-913.
- Flannery, J., Keaveney, S., Dore, W., 2009. Use of FRNA bacteriophages to indicate the risk of norovirus contamination in Irish oysters. *J. Food Protect.* 72, 2358-2362.
- Fumian, T.M., Leite, J.P., Castello, A.A., Gaggero, A., Caillou, M.S., Miagostovich, M.P., 2010. Detection of rotavirus A in sewage samples using multiplex qPCR and an evaluation of the ultracentrifugation and adsorption-elution methods for virus concentration. *J. Virol. Methods.* 170, 42-46.
- Gallimore, C.I., Pipkin, C., Shrimpton, H., Green, A.D., Pickford, Y., McCartney, C., Sutherland, G., Brown, D.W.G., Gray, J.J., 2005. Detection of multiple enteric virus strains within a foodborne outbreak of gastroenteritis: an indication of the source of contamination. *Epidemiol. Infect.* 133, 41-47.
- Gentry, J., Vinje, J., Lipp, E.K., 2009. A rapid and efficient method for quantitation of genogroups I and II norovirus from oysters and application in other complex environmental samples. *J. Virol. Methods.* 156, 59-65.
- Gibson, K.E., Schwab, K.J., 2011a. Tangential-flow ultrafiltration with integrated inhibition detection for recovery of surrogates and human pathogens from large-volume source water and finished drinking water. *Appl. Environ. Microbiol.* 77, 385-391.
- Gibson, K.E., Schwab, K.J., 2011b. Thermal inactivation of human norovirus surrogates. *Food Environ. Virol.* 3, 74-77.
- Gilbert, Y., Duchaine, C., 2009. Bioaerosols in industrial environments: A review. *Can. J. Civ. Eng.* 36, 1873-1886.
- Gilgen, M., Germann, D., Lüthy, J., Hübner, P., 1997. Three-step isolation method for sensitive detection of enterovirus, rotavirus, hepatitis A virus, and small round structured viruses in water samples. *Int. J. Food Microbiol.* 37, 189-199.
- Glass, P.J., White, L.J., Ball, J.M., Leparac-Goffart, I., Hardy, M.E., Estes, M.K., 2000. Norwalk virus open reading frame 3 encodes a minor structural protein. *J. Virol.* 74, 6581-6591.
- Glass, R.I., Parashar, U.D., Estes, M.K., 2009. Norovirus gastroenteritis. *New Engl. J. Med.* 361, 1776-1785.
- Goodfellow, I., Chaudhry, Y., Gioldasi, I., Gerondopoulos, A., Natoni, A., Labrie, L., Laliberté, J.F., Roberts, L., 2005. Calicivirus translation initiation requires an interaction between VPg and eIF 4 E. *EMBO Rep.* 6, 968-972.

- Goodridge,L., Griffiths,M., Goodridge,C., Pawliszyn,J., Wu,J., 2004. Isoelectric point determination of norovirus virus-like particles by capillary isoelectric focusing with whole column imaging detection. *Anal. Chem.* 76, 48-52.
- Gray,J.J., Kohli,E., Ruggeri,F.M., Vennema,H., Sanchez-Fauquier,A., Schreier,E., Gallimore,C.I., Iturriza-Gomara,M., Giraudon,H., Pothier,P., Di Bartolo,I., Inglese,N., de Bruin,E., van der Veer,B., Moreno,S., Montero,V., de Llano,M.C., Hoehne,M., Diedrich,S.M., 2007. European multicenter evaluation of commercial enzyme immunoassays for detecting norovirus antigen in fecal samples. *Clin. Vacc. Immunol.* 14, 1349-1355.
- Green,K.Y., Ando,T., Balayan,M.S., Berke,T., Clarke,I.N., Estes,M.K., Matson,D.O., Nakata,S., Neill,J.D., Studdert,M.J., Thiel,H.J., 2000. Taxonomy of the Caliciviruses. *J. Infec. Dis.* 181, S332.
- Greening,G.E., Hewitt,J., 2008. Norovirus detection in shellfish using a rapid, sensitive virus recovery and real-time RT-PCR detection protocol. *Food Anal. Methods.* 1, 109-118.
- Gregory,J.B., Webster,L.F., Griffith,J.F., Stewart,J.R., 2011. Improved detection and quantitation of norovirus from water. *J. Virol. Methods.* 172, 38-45.
- Grove,S.F., Lee,A., Lewis,T., Stewart,C.M., Haiqiang,C., Hoover,D.G., 2006. Inactivation of foodborne viruses of significance by high pressure and other processes. *J. Food Protect.* 69, 957-968.
- Grove,S.F., Forsyth,S., Wan,J., Coventry,J., Cole,M., Stewart,C.M., Lewis,T., Ross,T., Lee,A., 2008. Inactivation of hepatitis A virus, poliovirus and a norovirus surrogate by high pressure processing. *Innov. Food Sci. Technol.* 9, 206-210.
- Gulati,B.R., Allwood,P.B., Hedberg,C.W., Goyal,S.M., 2001. Efficacy of commonly used disinfectants for the inactivation of calicivirus on strawberry, lettuce, and a food-contact surface. *J. Food Protect.* 64, 1430-1434.
- Haramoto,E., Katayama,H., Oguma,K., Ohgaki,S., 2005. Application of cation-coated filter method to detection of noroviruses, enteroviruses, adenoviruses, and torque teno viruses in the Tamagawa River in Japan. *Appl. Environ. Microbiol.* 71, 2403-2411.
- Haramoto,E., Katayama,H., Utagawa,E., Ohgaki,S., 2009. Recovery of human norovirus from water by virus concentration methods. *J. Virol. Methods.* 160, 206-209.
- Haramoto,E., Ohgaki,S., Katayama,H., Haramoto,E., 2004. Detection of noroviruses in tap water in Japan by means of a new method for concentrating enteric viruses in large volumes of freshwater. *Appl. Environ. Microbiol.* 70, 2154-2160.
- Hardy,M.E., 2005. Norovirus protein structure and function. *FEMS Microbiol. Lett.* 253, 1-8.
- Hayden,O., Lieberzeit,P.A., Blaas,D., Dickert,F.L., 2006. Artificial Antibodies for Bioanalyte Detection - Sensing Viruses and Proteins. *Adv. Funct. Mater.* 16, 1269-1278.
- Hewitt,J., Rivera-Aban,M., Greening,G.E., 2009. Evaluation of murine norovirus as a surrogate for human norovirus and hepatitis A virus in heat inactivation studies. *J. Appl. Microbiol.* 107, 65-71.

- Hill,V.R., Kahler,A.M., Jothikumar,N., Johnson,T.B., Hahn,D., Cromeans,T.L., 2007. Multistate evaluation of an ultrafiltration-based procedure for simultaneous recovery of enteric microbes in 100-liter tap water samples. *Appl. Environ. Microbiol.* 73, 4218-4225.
- Hill,V.R., Mull,B., Jothikumar,N., Ferdinand,K., Vinje,J., 2010. Detection of GI and GII noroviruses in ground water using ultrafiltration and TaqMan real-time RT-PCR. *Food Environ. Virol.* 2, 218-224.
- Hill,V.R., Polaczyk,A.L., Kahler,A.M., Cromeans,T.L., Hahn,D., Amburgey,J.E., 2009. Comparison of hollow-fiber ultrafiltration to the USEPA VIRADEL technique and USEPA method 1623. *J. Environ. Qual.* 38, 822-825.
- Hogan,C.J., Kettleison,E.M., Lee,M.H., Ramaswami,B., Angenent,L.T., Biswas,P., 2005. Sampling methodologies and dosage assessment techniques for submicrometre and ultrafine virus aerosol particles. *J. Appl. Microbiol.* 99, 1422-1434.
- Höhne,M., Schreier,E., 2004. Detection and characterization of norovirus outbreaks in Germany: Application of a one-tube RT-PCR using a fluorogenic real-time detection system. *J. Med. Virol.* 72, 312-319.
- Huffman,D.E., Nelson,K.L., Rose,J.B., 2003. Calicivirus - An emerging contaminant in water: State of the art. *envir eng sci.* 20, 503-515.
- Hurst,C.J., Dahling,D.R., Safferman,R.S., Goyke,T., 1984. Comparison of commercial beef extract and similar materials for recovering viruses from environmental samples. *Can. J. Microbiol.* 30, 1253-1263.
- Hutson,A.M., Airaud,F., LePendou,J., Estes,M.K., Atmar,R.L., 2005. Norwalk virus infection associates with secretor status genotyped from sera. *J. Med. Virol.* 77, 116-120.
- Hutson,A.M., Atmar,R.L., Graham,D.Y., Estes,M.K., 2002. Norwalk virus infection and disease is associated with ABO histo-blood group type. *J. Infect. Dis.* 185, 1335-1337.
- Hyde,J.L., Mackenzie,J.M., 2010. Subcellular localization of the MNV-1 ORF1 proteins and their potential roles in the formation of the MNV-1 replication complex. *Virology.* 406, 138-148.
- Iizuka,S., Oka,T., Tabara,K., Omura,T., Katayama,K., Takeda,N., Noda,M., 2010. Detection of sapoviruses and noroviruses in an outbreak of gastroenteritis linked genetically to shellfish. *J. Med. Virol.* 82, 1247-1254.
- Ijaz,M.K., Karim,Y.G., Sattar,S.A., Johnson-Lussenburg,C.M., 1987. Development of methods to study the survival of airborne viruses. *J. Virol. Methods.* 18, 87-106.
- Ijaz,M.K., Sattar,S.A., Johnson-Lussenburg,C.M., Springthorpe,V.S., 1985a. Comparison of the airborne survival of calf rotavirus and poliovirus type 1 sabin aerosolized as a mixture. *Appl. Environ. Microbiol.* 49, 289-293.
- Ijaz,M.K., Sattar,S.A., Johnson-Lussenburg,C.M., Springthorpe,V.S., Nair,R.C., 1985b. Effect of relative humidity atmospheric temperature and suspending medium on the airborne survival of human rotavirus. *Can. J. Microbiol.* 31, 681-685.

- Ikner,L.A., Soto-Beltran,M., Bright,K.R., 2011. New method using a positively charged microporous filter and ultrafiltration for concentration of viruses from tap water. *Appl. Environ. Microbiol.* 77, 3500-3506.
- Jiang,X., Graham,D.Y., Wang,K., Estes,M.K., 1990. Norwalk virus genome cloning and characterization. *Science.* 250, 1580-1583.
- Jiang,X., Wang,M., Wang,K., Estes,M.K., 1993. Sequence and genomic organization of Norwalk virus. *Virology.* 195, 51-61.
- Jothikumar,N., Dwarkadas,A., Khanna,P., 1991. Evaluation of urea-arginine phosphate buffer (u-apb) for reconcentration of viruses in field samples. *Int. J. Environ. Stud.* 39, 231-236.
- Jothikumar,N., Lowther,J.A., Henshilwood,K., Lees,D.N., Hill,V.R., Vinje,J., 2005. Rapid and sensitive detection of noroviruses by using TaqMan-based one-step reverse transcription-PCR assays and application to naturally contaminated shellfish samples. *Appl. Environ. Microbiol.* 71, 1870-1875.
- Kageyama,T., Shinohara,M., Uchida,K., Fukushi,S., Hoshino,F.B., Kojima,S., Takai,R., Oka,T., Takeda,N., Katayama,K., 2004. Coexistence of multiple genotypes, including newly identified genotypes, in outbreaks of gastroenteritis due to norovirus in Japan. *J. Clin. Microbiol.* 42, 2988-2995.
- Kageyama,T., Kojima,S., Shinohara,M., Uchida,K., Fukushi,S., Hoshino,F.B., Takeda,N., Katayama,K., 2003. Broadly reactive and highly sensitive assay for Norwalk-like viruses based on real-time quantitative reverse transcription-PCR. *J. Clin. Microbiol.* 41, 1548-1557.
- Karim,M.R., Rhodes,E.R., Brinkman,N., Fout,G.S., Wymer,L., 2009. New electropositive filter for concentrating enteroviruses and noroviruses from large volumes of water. *Appl. Environ. Microbiol.* 75, 2393-2399.
- Katayama,H., Shimasaki,A., Ohgaki,S., 2002. Development of a virus concentration method and its application to detection of enterovirus and Norwalk virus from coastal seawater. *Appl. Environ. Microbiol.* 68, 1033-1039.
- Katzenelson,E., Fattal,B., Hostovesky,T., 1976. Organic flocculation: an efficient second-step concentration method for the detection of viruses in tap water. *Appl. Environ. Microbiol.* 32, 638-639.
- Kele,B., Lengyel,G., Deak,J., 2011. Comparison of an ELISA and two reverse transcription polymerase chain reaction methods for norovirus detection. *Diagn. Microbiol. Infect. Dis.* 70, 475-478.
- Kim,K., Katayama,H., Kitajima,M., Ohgaki,S., Tohya,Y., 2011. Development of a real-time RT-PCR assay combined with ethidium monoazide treatment for RNA viruses and its application to detect viral RNA after heat exposure. *Water Sci. Technol.* 63, 502-507.
- Kindberg,E., Akerlind,B., Johnsen,C., Knudsen,J.D., Heltberg,O., Larson,G., Boettiger,B., Svensson,L., 2007. Host genetic resistance to symptomatic norovirus (GGII.4) infections in denmark. *J. Clin. Microbiol.* 45, 2720-2722.

- Kingsley,D.H., Dongsheng,G., Hoover,D.G., Haiqiang,C., 2006. Inactivation of hepatitis A virus by high-pressure processing: the role of temperature and pressure oscillation. *J. Food Protect.* 69, 2454-2459.
- Kingsley,D.H., Haiqiang,C., 2008. Aqueous matrix compositions and pH influence feline calicivirus inactivation by high pressure processing. *J. Food Protect.* 71, 1598-1603.
- Kingsley,D.H., Hoover,D.G., Papafragkou,E., Richards,G.P., 2002. Inactivation of hepatitis A virus and a calicivirus by high hydrostatic pressure. *J. Food Protect.* 65, 1605-1609.
- Kingsley,D.H., Richards,G.P., 2001. Rapid and efficient extraction method for reverse transcription-PCR detection of hepatitis A and Norwalk-like viruses in shellfish. *Appl. Environ. Microbiol.* 67, 4152-4157.
- Kingsley,D.H., Richards,G.P., 2003. Caliciviruses. In *International Handbook of Foodborne Pathogens*. Editors Miliotis,M.D and Bier,J.W. p1-13. New York: Marcel Dekker, Inc.
- Kingsley,D.H., Holliman,D.R., Flick,G.J., Calci,K.R., Chen,H., 2007. Inactivation of a norovirus by high-pressure processing. *Appl. Environ. Microbiol.* 73, 581-585.
- Koopmans,M., Duizer,E., 2004. Foodborne viruses: an emerging problem. *Int. J. Food Microbiol.* 90, 23-41.
- Kovac,K., Diez-Valcarce,M., Hernandez,M., Raspor,P., Rodriguez-Lazaro,D., 2010. High hydrostatic pressure as emergent technology for the elimination of foodborne viruses. *Trends Food Sci. Technol.* 21, 558-568.
- Kovac,K., Diez-Valcarce,M., Raspor,P., Hernandez,M., Rodriguez-Lazaro,D., 2012. Effect of high hydrostatic pressure processing on norovirus infectivity and genome stability in strawberry puree and mineral water. *Int. J. Food Microbiol.* 152, 35-39.
- Kuyumcu-Martinez,M., Belliot,G., Sosnovtsev,S.V., Kyeong-Ok,C., Green,K.Y., Lloyd,R.E., 2004. Calicivirus 3C-like proteinase inhibits cellular translation by cleavage of poly(A)-binding protein. *J. Virol.* 78, 8172-8182.
- Lambertini,E., Loge,F.J., Spencer,S.K., Bertz,P.D., Kieke,B.A., Borchardt,M.A., 2008. Concentration of enteroviruses, adenoviruses, and noroviruses from drinking water by use of glass wool filters. *Appl. Environ. Microbiol.* 74, 2990-2996.
- Lamhoujeb,S., Fliss,I., Ngazoa,S.E., Jean,J., 2009. Molecular study of the persistence of infectious human norovirus on food-contact surfaces. *Food Environ. Virol.* 1, 51-56.
- Lance,J.C., Gerba,C.P., 1984. Effect of ionic composition of suspending solution on virus adsorption by a soil column. *Appl. Environ. Microbiol.* 47, 484-488.
- Laskin,A., Cowin,J.P., 2002. On deposition efficiency of point-to-plate electrostatic precipitator. *Journal of Aerosol Science.* 33, 405-409.
- Laverick,M.A., Wyn-Jones,A.P., Carter,M.J., 2004. Quantitative RT-PCR for the enumeration of noroviruses (Norwalk-like viruses) in water and sewage. *Lett. Appl. Microbiol.* 39, 127-136.

- Le Guyader, F.S., Atmar, R.L., 2007. Chapter 10 Viruses in Shellfish. In *Perspectives in Medical Virology vol 17. Human Viruses in Water*. Editor Bosch, A. p205-226. Oxford: Elsevier.
- Le Guyader, F.S., Haugarreau, L., Miossec, L., Dubois, E., Pommepuy, M., 2000. Three-year study to assess human enteric viruses in shellfish. *Appl. Environ. Microbiol.* 66, 3241-3248.
- Le Guyader, F.S., Mittelholzer, C., Haugarreau, L., Hedlund, K.O., Alsterlund, R., Pommepuy, M., Svensson, L., 2004a. Detection of noroviruses in raspberries associated with a gastroenteritis outbreak. *Int. J. Food Microbiol.* 97, 179-186.
- Le Guyader, F.S., Neill, F.H., Estes, M.K., Monroe, S.S., Ando, T., Atmar, R.L., 1996. Detection and analysis of a small round-structured virus strain in oysters implicated in an outbreak of acute gastroenteritis. *Appl. Environ. Microbiol.* 62, 4268-4272.
- Le Guyader, F.S., Parnaudeau, S., Schaeffer, J., Bosch, A., Loisy, F., Pommepuy, M., Atmar, R.L., 2009. Detection and quantification of noroviruses in shellfish. *Appl. Environ. Microbiol.* 75, 618-624.
- Le Guyader, F.S., Schultz, A.C., Haugarreau, L., Croci, L., Maunula, L., Duizer, E., Lodder-Verschoor, F., Bonsdorff, C.H., Suffredini, E., Poel, W.M.M., Reymundo, R., Koopmans, M., 2004b. Round-robin comparison of methods for the detection of human enteric viruses in lettuce. *J. Food Protect.* 67, 2315-2319.
- Lee, H., Kim, M., Paik, S.Y., Lee, C.H., Jheong, W.H., Kim, J., Ko, G., 2011. Evaluation of electropositive filtration for recovering norovirus in water. *J. Water Health.* 9, 27-36.
- Lees, D., CEN, W.G., 2010. International standardisation of a method for detection of human pathogenic viruses in molluscan shellfish. *Food Environ. Virol.* 2, 146-155.
- Leon, J.S., Montes, J.S., Fernandez, M.L., Teunis, P.F., Moe, C.L., Kingsley, D.H., Richards, G.P., Lyon, G.M., Abdulhafid, G.M., Seitz, S.R., Flick, G.J., 2011. Randomized, double-blinded clinical trial for human norovirus inactivation in oysters by high hydrostatic pressure processing. *Appl. Environ. Microbiol.* 77, 5476-5482.
- Li, D., Baert, L., de Jonghe, M., Devlieghere, F., Uyttendaele, M., van Coillie, E., Ryckeboer, J., 2011a. Inactivation of murine norovirus 1, coliphage ϕ X174, and *Bacillus fragilis* phage B40-8 on surfaces and fresh-cut iceberg lettuce by hydrogen peroxide and UV light. *Appl. Environ. Microbiol.* 77, 1399-1404.
- Li, D., Baert, L., van Coillie, E., Uyttendaele, M., 2011b. Critical studies on binding-based RT-PCR detection of infectious Noroviruses. *J. Virol. Methods.* 177, 153-159.
- Lindesmith, L., Moe, C., LePendou, J., Frelinger, J.A., Treanor, J., Baric, R.S., 2005. Cellular and humoral immunity following Snow Mountain virus challenge. *J. Virol.* 79, 2900-2909.
- Lindesmith, L., Moe, C., Marionneau, S., Ruvoen, N., Jiang, X., Lindblad, L., Stewart, P., LePendou, J., Baric, R., 2003. Human susceptibility and resistance to Norwalk virus infection. *Nat. Med.* 9, 548-553.

- Lodder,W.J., van den Berg,H.H.J.L., Rutjes,S.A., Husman,A.M., 2010. Presence of enteric viruses in source waters for drinking water production in the Netherlands 80. *Appl. Environ. Microbiol.* 76, 5965-5971.
- Logan,C., O'Leary,J.J., O'Sullivan,N., 2007. Real-time reverse transcription PCR detection of norovirus, sapovirus and astrovirus as causative agents of acute viral gastroenteritis. *J. Virol. Methods.* 146, 36-44.
- Loisy,F., Atmar,R.L., Guillon,P., Le Cann,P., Pommepuy,M., Le Guyader,F.S., 2005. Real-time RT-PCR for norovirus screening in shellfish. *J. Virol. Methods.* 123, 1-7.
- Lopman,B., Armstrong,B., Atchison,C., Gray,J.J., 2009. Host, weather and virological factors drive norovirus epidemiology: Time-series analysis of laboratory surveillance data in England and Wales. *PLoS One.* 4, e6671.
- Lou,F., Li,J., Neetoo,H., Chen,H., 2011. Inactivation of a human norovirus surrogate by high-pressure processing: Effectiveness, mechanism, and potential application in the fresh produce industry. *Appl. Environ. Microbiol.* 77, 1862-1871.
- Madsen,A.M., Sharma,A.K., 2008. Sampling of High Amounts of Bioaerosols Using a High-Volume Electrostatic Field Sampler. *Ann. Occup. Health.* 52, 167-176.
- Makary,P., Maunula,L., Niskanen,T., Kuusi,M., Virtanen,M., Pajunen,S., Ollgren,J., Tran Minh,N.N., 2009. Multiple norovirus outbreaks among workplace canteen users in Finland, July 2006. *Epidemiol. Infect.* 137, 402-407.
- Manor,Y., Handsher,R., Halmut,T., Neuman,M., Bobrov,A., Rudich,H., Vonsover,A., Shulman,L., Kew,O., Mendelson,E., 1999. Detection of poliovirus circulation by environmental surveillance in the absence of clinical cases in Israel and the Palestinian Authority. *J. Clin. Microbiol.* 37, 1670-1675.
- Marks,P.J., Vipond,I.B., Carlisle,D., Deakin,D., Fey,R.E., Caul,E.O., 2000. Evidence for airborne transmission of Norwalk-like virus (NLV) in a hotel restaurant. *Epidemiol. Infect.* 124, 481-487.
- Marks,P.J., Vipond,I.B., Regan,F.M., Wedgwood,K., Fey,R.E., Caul,E.O., 2003. A school outbreak of Norwalk-like virus: Evidence for airborne transmission. *Epidemiol. Infect.* 131, 727-736.
- Mattison,K., Bidawid,S., 2009. Analytical methods for food and environmental viruses. *Food Environ. Virol.* 1, 107-122.
- Mattison,K., Brassard,J., Gagné,M.J., Ward,P., Houde,A., Lessard,L., Simard,C., Shukla,A., Pagotto,F., Jones,T.H., Trottier,Y.L., 2009. The feline calicivirus as a sample process control for the detection of food and waterborne RNA viruses. *Int. J. Food Microbiol.* 132, 73-77.
- Maunula,L., Klemola,P., Kauppinen,A., Soderberg,K., Nguyen,T., Pitkanen,T., Kaijalainen,S., Simonen,M.L., Miettinen,I.T., Lappalainen,M., Laine,J., Vuento,R., Kuusi,M., Roivainen,M., 2009a. Enteric Viruses in a Large Waterborne Outbreak of Acute Gastroenteritis in Finland 82. *Food Environ. Virol.* 1, 31-36.

- Maunula,L., Roivainen,M., Ker+ñinen,M., M+ñkela,S., S+Âderberg,K., Summa,M., von Bonsdorff,C.H., Lappalainen,M., Korhonen,T., Kuusi,M., Niskanen,T., 2009b. Detection of human norovirus from frozen raspberries in a cluster of gastroenteritis outbreaks. *Euro. Surveill.* 14.
- Maunula,L., Miettinen,I.T., von Bonsdorff,C.H., 2005. Norovirus outbreaks from drinking water 79. *Emerging Infect. Dis.* 11, 1716-1721.
- Moore,B.E., Sagik,B.P., Sorber,C.A., 1979. Procedure for the recovery of airborne human enteric viruses during spray irrigation of treated wastewater. *Appl. Environ. Microbiol.* 38, 688-693.
- Morales-Rayas,R., Wolffs,P.F.G., Griffiths,M.W., 2010. Simultaneous separation and detection of hepatitis A virus and norovirus in produce. *Int. J. Food Microbiol.* 139, 48-55.
- Morillo,S.G., Luchs,A., Cilli,A., Ribeiro,C.D., Calux,S.J., Carmona,R.d.C.C., Timenetsky,M.d.C.S.T., 2011. Norovirus 3rd Generation kit: An improvement for rapid diagnosis of sporadic gastroenteritis cases and valuable for outbreak detection. *J. Virol. Methods.* 173, 13-16.
- Mounts,A.W., Ando,T., Koopmans,M., Bresee,J.S., Noel,J., Glass,R.I., 2000. Cold weather seasonality of gastroenteritis associated with Norwalk-like viruses. *J. Infect. Dis.* 181, S284-S287.
- Mullendore,J.L., Sobsey,M.D., Shieh,Y.S.C., 2001. Improved method for the recovery of hepatitis A virus from oysters. *J. Virol. Methods.* 94, 25-35.
- Muniain-Mujika,I., Girones,R., Lucena,F., 2000. Viral contamination of shellfish: evaluation of methods and analysis of bacteriophages and human viruses. *J. Virol. Methods.* 89, 109-118.
- Murchie,L.W., Kelly,A.L., Wiley,M., Adair,B.M., Patterson,M., 2007. Inactivation of a calicivirus and enterovirus in shellfish by high pressure. *Innov. Food Sci. Technol.* 8, 213-217.
- Myrmel,M., Rimstad,E., Berg,E.M.M., Grinde,B., 2004. Detection of enteric viruses in shellfish from the Norwegian coast. *Appl. Environ. Microbiol.* 70, 2678-2684.
- Nishida,T., Kimura,H., Saitoh,M., Kozawa,K., Kato,M., Shinohara,M., Fukuda,S., Munemura,T., Mikami,T., Kawamoto,A., Akiyama,M., Kato,Y., Nishio,O., Nishi,K., Kimura,H., 2003. Detection, quantitation, and phylogenetic analysis of noroviruses in Japanese oysters. *Appl. Environ. Microbiol.* 69, 5782-5786.
- Nordgren,J., Kindberg,E., Lindgren,P.E., Matussek,A., Svensson,L., 2010. Norovirus gastroenteritis outbreak with a secretor-independent susceptibility pattern, Sweden. *Emerging Infect. Dis.* 16, 81-87.
- Nuanualsuwan,S., Cliver,D.O., 2002. Pretreatment to avoid positive RT-PCR results with inactivated viruses. *J. Virol. Methods.* 104, 217-225.
- Nygaard,K., Vold,L., Halvorsen,E., Bringeland,E., Rottingen,J.A., Aavitsland,P., 2004. Waterborne outbreak of gastroenteritis in a religious summer camp in Norway, 2002 81. *Epidemiol. Infect.* 132, 223-229.

- Nygaard,K., Torven,M., Ancker,C., Knauth,S.B., Hedlund,K.O., Giesecke,J., Andersson,Y., Svensson,L., 2003. Emerging genotype (GGIIb) of norovirus in drinking water, Sweden 86. *Emerging Infect. Dis.* 9, 1548-1552.
- Pang,X.L., Preiksaitis,J.K., Lee,B., 2005. Multiplex real time RT-PCR for the detection and quantitation of norovirus genogroups I and II in patients with acute gastroenteritis. *J. Clin. Virol.* 33, 168-171.
- Park,G.W., Linden,K.G., Sobsey,M.D., 2011a. Inactivation of murine norovirus, feline calicivirus and echovirus 12 as surrogates for human norovirus (NoV) and coliphage (F+) MS2 by ultraviolet light (254 nm) and the effect of cell association on UV inactivation. *Lett. Appl. Microbiol.* 52, 162-167.
- Park,Y., Cho,Y.H., Ko,G., 2011b. A duplex real-time RT-PCR assay for the simultaneous genogroup-specific detection of noroviruses in both clinical and environmental specimens. *Virus Genes.* 43, 192-200.
- Parrino,T.A., Schreiber,D.S., Trier,J.S., Kapikian,A.Z., Blacklow,N.R., 1977. Clinical immunity in acute gastroenteritis caused by Norwalk agent. *New Engl. J. Med.* 297, 86-89.
- Parshionikar,S., Laseke,I., Fout,G.S., 2010. Use of propidium monoazide in reverse transcriptase PCR to distinguish between infectious and noninfectious enteric viruses in water samples. *Appl. Environ. Microbiol.* 76, 4318-4326.
- Pavanasam,A.K., Chen,V., Abbas,A., 2011. Influence of particle size and operating parameters on virus ultrafiltration efficiency. *Water Sci. Technol. Water Supply.* 11, 31-38.
- Pfister,T., Wimmer,E., 2001. Polypeptide p41 of a Norwalk-like virus is a nucleic acid-independent nucleoside triphosphatase. *J. Virol.* 75, 1611-1619.
- Pina,S., Puig,M., Lucena,F., Jofre,J., Girones,R., 1998. Viral pollution in the environment and in shellfish: human adenovirus detection by PCR as an index of human viruses. *Appl. Environ. Microbiol.* 64, 3376-3382.
- Pinto,R.M., Costafreda,M.I., Bosch,A., 2009. Risk assessment in shellfish-borne outbreaks of hepatitis A. *Appl. Environ. Microbiol.* 75, 7350-7355.
- Pirtle,E.C., Beran,G.W., 1991. Virus survival in the environment. *Rev. Sci. Tech.* 10, 733-748.
- Prasad,B.V., Hardy,M.E., Dokland,T., Bella,J., Rossmann,M.G., Estes,M.K., 1999. X-ray crystallographic structure of the Norwalk virus capsid. *Science* 286, 287-290.
- Prasad,B.V., Matson,D.O., Smith,A.W., 1994. Three-dimensional Structure of Calicivirus. *Journal of Molecular Biology.* 240, 256-264.
- Prato,R., Lopalco,P.L., Chironna,M., 2004. Norovirus gastroenteritis general outbreak associated with raw shellfish consumption in South Italy. *BMC Infectious Diseases.* 4.

- Radin,D., D'Souza,D.H., 2011a. Evaluation of two primer sets using newly developed internal amplification controls for rapid human norovirus detection by SYBR green I based real-time RT-PCR. *Food Environ. Virol.* 3, 61-69.
- Radin,D., D'Souza,D.H., 2011b. Simple and rapid detection of human norovirus from produce using SYBR green I-based real-time RT-PCR. *Food Environ. Virol.* 3, 121-129.
- Räsänen,S., Lappalainen,M., Kaikkonen,S., Hämäläinen,M., Salminen,M., Vesikari,T., 2010. Mixed viral infections causing acute gastroenteritis in children in a waterborne outbreak 83. *Epidemiol. Infect.* 138, 1227-1234.
- Rhodes,E.R., Hamilton,D.W., See,M.J., Wymer,L., 2011. Evaluation of hollow-fiber ultrafiltration primary concentration of pathogens and secondary concentration of viruses from water. *J. Virol. Methods.* 176, 38-45.
- Richards,G.P., Watson,M.A., Fankhauser,R.L., Monroe,S.S., 2004a. Genogroup I and II noroviruses detected in stool samples by real-time reverse transcription-PCR using highly degenerate universal primers. *Appl. Environ. Microbiol.* 70, 7179-7184.
- Richards,G.P., Watson,M.A., Kingsley,D.H., 2004b. A SYBR green, real-time RT-PCR method to detect and quantitate Norwalk virus in stools. *J. Virol. Methods.* 116, 63-70.
- Riera-Montes,M., Sjolander,K.B., Allestam,G., Hallin,E., Hedlund,K.O., Lofdahl,M., 2011. Waterborne norovirus outbreak in a municipal drinking-water supply in Sweden. *Epidemiol. Infect.* 139, 1928-1935.
- Rodriguez-Diaz,J., Querales,L., Caraballo,L., Vizzi,E., Liprandi,F., Takiff,H., Betancourt,W.Q., 2009. Detection and characterization of waterborne gastroenteritis viruses in urban sewage and sewage-polluted river waters in Caracas, Venezuela. *Appl. Environ. Microbiol.* 75, 387-394.
- Rohayem,J., Robel,I., Jaeger,K., Scheffler,U., Rudolph,W., 2006. Protein-primed and de novo initiation of RNA synthesis by norovirus 3D(pol). *J. Virol.* 80, 7060-7069.
- Rydell,G.E., Kindberg,E., Larson,G., Svensson,L., 2011. Susceptibility to winter vomiting disease: a sweet matter. *Rev. Med. Virol.* 21, 370-382.
- Rzewutka,A., Alotaibi,M., D'Agostino,M., Cook,N., Agostino,M.d., 2005. A centrifugation-based method for extraction of norovirus from raspberries. *J. Food Protect.* 68, 1923-1925.
- Rzewutka,A., D'Agostino,M., Cook,N., 2006. An ultracentrifugation-based approach to the detection of hepatitis A virus in soft fruits. *Int. J. Food Microbiol.* 108, 315-320.
- Sattar,S.A., Ijaz,M.K., Johnson-Lussenburg,C.M., Springthorpe,V.S., 1984. Effect of relative humidity on the airborne survival of rotavirus SA-11. *Appl. Environ. Microbiol.* 47, 879-881.
- Schreiber,D.S., Blacklow,N.R., Trier,J.S., 1973. The mucosal lesion of the proximal small intestine in acute infectious nonbacterial gastroenteritis. *New Engl. J. Med.* 288, 1318-1323.

- Schultz,A.C., Perelle,S., Pasquale,S.d., Kovac,K., Medici,D.d., Fach,P., Sommer,H.M., Hoorfar,J., 2011a. Collaborative validation of a rapid method for efficient virus concentration in bottled water. *Int. J. Food Microbiol.* 145, S158-S166.
- Schultz,A.C., Vega,E., Dalsgaard,A., Christensen,L.S., Nørrung,B., Hoorfar,J., Vinje,J., 2011b. Development and evaluation of novel one-step TaqMan realtime RT-PCR assays for the detection and direct genotyping of genogroup I and II noroviruses. *J. Clin. Virol.* 50, 230-234.
- Seitz,S.R., Leon,J.S., Schwab,K.J., Lyon,G.M., Dowd,M., McDaniels,M., Abdulhafid,G., Fernandez,M.L., Lindesmith,L.C., Baric,R.S., Moe,C.L., 2011. Norovirus infectivity in humans and persistence in water. *Appl. Environ. Microbiol.* 77, 6884-6888.
- Sekla,L., Stackiw,W., Kay,C., VanBuckenhouet,L., 1980. Enteric viruses in renovated water in Manitoba. *Can. J. Microbiol.* 26, 518-523.
- Sharma,M., Shearer,A.E.H., Hoover,D.G., Liu,M.N., Solomon,M.B., Kniel,K.E., 2008. Comparison of hydrostatic and hydrodynamic pressure to inactivate foodborne viruses. *Innov. Food Sci. Technol.* 9, 418-422.
- Sharp,T.M., Guix,S., Katayama,K., Crawford,S.E., Estes,M.K., 2010. Inhibition of cellular protein secretion by Norwalk virus nonstructural protein p22 requires a mimic of an endoplasmic reticulum export signal. *PLoS One.* 5, e13130.
- Shieh,Y.S.C., Calci,K.R., Baric,R.S., 1999. A method to detect low levels of enteric viruses in contaminated oysters. *Appl. Environ. Microbiol.* 65, 4709-4714.
- Shields,P.A., Farrah,S.R., 1986. Concentration of viruses in beef extract by flocculation with ammonium sulfate. *Appl. Environ. Microbiol.* 51, 211-213.
- Slomka,M.J., Appleton,H., 1998. Feline calicivirus as a model system for heat inactivation studies of small round structured viruses in shellfish. *Epidemiol. Infect.* 121, 401-407.
- Sobsey,M.D., Carrick,R.J., Jensen,H.R., 1978. Improved methods for detecting enteric viruses in oysters. *Appl. Environ. Microbiol.* 36, 121-128.
- Sobsey,M.D., Glass,J.S., 1984. Influence of water quality on enteric virus concentration by microporous filter methods. *Appl. Environ. Microbiol.* 47, 956-960.
- Sobsey,M.D., Jones,B.L., 1979. Concentration of poliovirus from tap water using positively charged microporous filters. *Appl. Environ. Microbiol.* 37, 588-595.
- Sobsey,M.D., Moore,R.S., Glass,J.S., 1981. Evaluating adsorbent filter performance for enteric virus concentrations in tap water. *J. Am. Water Works Assoc.* 73, 542-548.
- Someya,Y., Takeda,N., Miyamura,T., 2002. Identification of active-site amino acid residues in the Chiba virus 3C-like protease. *J. Virol.* 76, 5949-5958.
- Souza,M., Azevedo,M.S.P., Jung,K., Cheetham,S., Saif,L.J., 2008. Pathogenesis and immune responses in gnotobiotic calves after infection with the genogroup II.4-HS66 strain of human norovirus. *J. Virol.* 82, 1777-1786.

- Sow,H., Desbiens,M., Morales-Rayas,R., Ngazoa,S.E., Jean,J., 2011. Heat inactivation of hepatitis A virus and a norovirus surrogate in soft-shell clams (*Mya arenaria*). *Foodborne Pathog. Dis.* 8, 387-393.
- Stals,A., Baert,L., Botteldoorn,N., Werbrouck,H., Herman,L., Uyttendaele,M., van Coillie,E., 2009. Multiplex real-time RT-PCR for simultaneous detection of GI/GII noroviruses and murine norovirus 1. *J. Virol. Methods.* 161, 247-253.
- Stals,A., Baert,L., van Coillie,E., Uyttendaele,M., 2011. Evaluation of a norovirus detection methodology for soft red fruits. *Food Microbiol.* 28, 52-58.
- Su,X., Zivanovic,S., D'Souza,D.H., 2010. Inactivation of human enteric virus surrogates by high-intensity ultrasound. *Foodborne Pathog. Dis.* 7, 1055-1061.
- Suñén,E., Sobsey,M.D., 1999. Recovery and detection of enterovirus, hepatitis A virus and Norwalk virus in hardshell clams (*Mercenaria mercenaria*) by RT-PCR methods. *J. Virol. Methods.* 77, 179-187.
- Svraka,S., Duizer,E., Vennema,H., Bruin,E.d., Veer,B.v.d., Dorresteyn,B., Koopmans,M., 2007. Etiological role of viruses in outbreaks of acute gastroenteritis in the Netherlands from 1994 through 2005. *J. Clin. Microbiol.* 45, 1389-1394.
- Tan,M., Jiang,X., 2005. Norovirus and its histo-blood group antigen receptors: an answer to a historical puzzle. *Trends Microbiol.* 13, 285-293.
- Tan,M., Jiang,X., 2011. Norovirus-host interaction: Multi-selections by human histo-blood group antigens. *Trends Microbiol.* 19, 382-388.
- Tan,M., Jin,M., Xie,H., Duan,Z., Jiang,X., Fang,Z., 2008. Outbreak studies of a GII-3 and a GII-4 norovirus revealed an association between HBGA phenotypes and viral infection. *J. Med. Virol.* 80, 1296-1301.
- Taylor,M.B., Cox,N., Vrey,M.A., Grabow,W.O.K., 2001. The occurrence of hepatitis A and astroviruses in selected river and dam waters in South Africa. *Water Res.* 35, 2653-2660.
- Teltsch,B., Katzenelson,E., 1978. Airborne enteric bacteria and viruses from spray irrigation with wastewater. *Appl. Environ. Microbiol.* 35, 290-296.
- ter Waarbeek,H.L.G., Dukers-Muijers,N.H.T.M., Vennema,H., Hoebe,C.J.P.A., 2010. Waterborne gastroenteritis outbreak at a scouting camp caused by two norovirus genogroups: GI and GII 85. *J. Clin. Virol.* 47, 268-272.
- Teunis,P.F.M., Moe,C.L., Liu,P., Miller,E., Lindesmith,L., Baric,R.S., Le Pendu,J., Calderon,R.L., 2008. Norwalk virus: How infectious is it? *J. Med. Virol.* 80, 1468-1476.
- Trujillo,A.A., McCaustland,K.A., Du-Ping,Z., Hadley,L.A., Vaughn,G., Adams,S.M., Ando,T., Glass,R.I., Monroe,S.S., 2006. Use of TaqMan real-time reverse transcription-PCR for rapid detection, quantification, and typing of norovirus. *J. Clin. Microbiol.* 44, 1405-1412.

- Tseng,C.C., Chang,L.Y., Li,C.S., 2010. Detection of airborne viruses in a pediatrics department measured using real-time qPCR coupled to an air-sampling filter method. *J. Environ. Health.* 73, 22-28.
- Uhrbrand,K., Myrnel,M., Maunula,L., Vainio,K., Trebbien,R., Nørrung,B., Schultz,A.C., 2010. Evaluation of a rapid method for recovery of norovirus and hepatitis A virus from oysters and blue mussels. *J. Virol. Methods.* 169, 70-78.
- Uhrbrand,K., Schultz,A.C., Madsen,A.M., 2011. Exposure to airborne noroviruses and other bioaerosol components at a wastewater treatment plant in Denmark. *Food Environ. Virol.* 3, 130-137.
- van Heerden,J., Ehlers,M.M., van Zyl,W.B., Grabow,W.O.K., 2004. Prevalence of human adenoviruses in raw and treated water. *Water Sci. Technol.* 50, 39-43.
- van Zyl,W.B., Page,N.A., Grabow,W.O.K., Steele,A.D., Taylor,M.B., 2006. Molecular epidemiology of group A rotaviruses in water sources and selected raw vegetables in Southern Africa. *Appl. Environ. Microbiol.* 72, 4554-4560.
- van Zyl,W.B., Williams,P.J., Grabow,W.O.K., Taylor,M.B., 2004. Application of a molecular method for the detection of group A rotaviruses in raw and treated water. *Water Sci. Technol.* 50, 223-228.
- Vasickova,P., Dvorska,L., Lorencova,A., Pavlik,I., 2005. Viruses as a cause of foodborne diseases: a review of the literature. *Vet. Med.* 50, 89-104.
- Venter,J.M.E., van Heerden,J., Vivier,J.C., Grabow,W.O.K., Taylor,M.B., 2007. Hepatitis A virus in surface water in South Africa: what are the risks? *J. Water Health.* 5, 229-240.
- Verreault,D., Moineau,S., Duchaine,C., 2008. Methods for sampling of airborne viruses. *Microbiol. Mol. Biol. Rev.* 72, 413-444.
- Victoria,M., Guimarães,F., Fumian,T., Ferreira,F., Vieira,C., Leite,J.P., Miagostovich,M., 2009. Evaluation of an adsorption-elution method for detection of astrovirus and norovirus in environmental waters. *J. Virol. Methods.* 156, 73-76.
- Wadl,M., Scherer,K., Nielsen,S., Diedrich,S., Ellerbroek,L.+, Frank,C., Gatzer,R., Hoehne,M., Johne,R., Klein,G.+, Koch,J., Schulenburg,J.+, Thielbein,U., Stark,K., Bernard,H., 2010. Food-borne norovirus-outbreak at a military base, Germany, 2009. *BMC Infectious Diseases.* 10.
- Wallis,C., Melnick,J.L., Rao,C.C., Sox,T.E., 1985. Method for detecting viruses in aerosols. *Appl. Environ. Microbiol.* 50, 1181-1186.
- Wei,J., Kniel,K.E., 2010. Pre-harvest Viral Contamination of Crops Originating from Fecal Matter. *Food Environ. Virol.* 2, 195-206.
- Westrell,T., Dusch,V., Ethelberg,S., Harris,J., Hjertqvist,M., Jourdan-da Silva,N., Koller,A., Lenglet,A., Lisby,M., Vold,L., 2010. Norovirus outbreaks linked to oyster consumption in the United Kingdom, Norway, France, Sweden and Denmark, 2010. *Euro surveillance.* 15.

Wilson,I.G., 1997. Inhibition and facilitation of nucleic acid amplification. *Appl. Environ. Microbiol.* 63, 3741-3751.

Wyatt,Rx.Gx., Dolin,Rx., Blacklow,N.R., Dupont,H.L., Buscho,R.F., Thornhill,T.S., Kapikian,A.Z., Chanock,R.M., 1974. Comparison of 3 agents of acute infectious nonbacterial gastroenteritis by cross-challenge in volunteers. *J. Infect. Dis.* 129, 709-714.

Wyn-Jones,A.P., Sellwood,J., 2001. Enteric viruses in the aquatic environment. *J. Appl. Microbiol.* 91, 945-962.

Zhang,Y., Song,D., Lanni,L.M., Shimizu,K.D., 2010. Importance of Functional Monomer Dimerization in the Molecular Imprinting Process. *Macromolecules.* 43, 6284-6294.

Zheng,D.P., Ando,T., Fankhauser,R.L., Beard,R.S., Glass,R.I., Monroe,S.S., 2006. Norovirus classification and proposed strain nomenclature. *Virology.* 346, 312-323.

Ziros,P.G., Kokkinos,P.A., Legaki,E., Vantarakis,A., 2011. Development of an optimized method for the detection of airborne viruses with real-time PCR analysis. *Virol. J.* 8, 369.