

Technical University of Denmark



Investigation and Retrofitting Proposal for a Panbo Type House in Sisimiut, Greenland

Qu, Jing; Vladyková, Petra; Villumsen, Arne

Publication date:
2012

[Link back to DTU Orbit](#)

Citation (APA):

Qu, J., Vladyková, P., & Villumsen, A. (2012). Investigation and Retrofitting Proposal for a Panbo Type House in Sisimiut, Greenland. Paper presented at Artek Event , Sisimiut, Greenland.

DTU Library

Technical Information Center of Denmark

General rights

Copyright and moral rights for the publications made accessible in the public portal are retained by the authors and/or other copyright owners and it is a condition of accessing publications that users recognise and abide by the legal requirements associated with these rights.

- Users may download and print one copy of any publication from the public portal for the purpose of private study or research.
- You may not further distribute the material or use it for any profit-making activity or commercial gain
- You may freely distribute the URL identifying the publication in the public portal

If you believe that this document breaches copyright please contact us providing details, and we will remove access to the work immediately and investigate your claim.

Investigation and Retrofitting Proposal for a Panbo Type House in Sisimiut, Greenland

Jing Qu^{1*}, Petra Vladyková², Arne Villumsen¹

¹ The Arctic Technology Centre, Department of Civil Engineering, Technical University of Denmark. DK-2800 Lyngby, Denmark

² Swegon AB, PO Box 336, 401 25 Göteborg, Sweden

* Speaker, e-mail: jinq@byg.dtu.dk

Abstract

The 'Blue House' is a standard family detached house built by Panbo Huse A/S in 1985 in Sisimiut, Greenland. As an old building, it has many problems such as poor thermal comfort and high energy consumption, and therefore, the house has a potential to be retrofitted. The investigation of the 'Blue House' was carried out in August 2011, including collection of original documentation, visual inspection, blower-door test, thermography test, the indoor climate monitoring, questionnaire and interview with the occupants. The indoor climate, including temperature and relative humidity, has been recorded since December 2010. The results of the investigation show that the house has some serious problems influencing proper functions, such as thermal bridges, poor thermal comfort and high energy consumption. A retrofitting plan, including having an additional paper insulation layer and exterior climate shield, has been proposed and will be carried out in 2012. Although the blower-door test shows that comparing with the considerably large number of houses built in past times in Greenland, the 'Blue House' has a relatively high air tightness, the thermal performance of the house needs to be improved. Due to the harsh climate in Greenland and the low building standard in the earlier period, it is still a major challenge for Greenlandic building industry to retrofit existing buildings.

1. Introduction

Located in Sisimiut, Greenland, the 'Blue House' is owned by the Municipality of Qeqqata and rented to a local family. It is a standard family detached house built by Panbo Huse A/S in 1985. Since 2010 an investigation on the blue house has started. The inhabitants' feedback and the investigation show that this old building has many problems, such as poor thermal comfort, high energy consumption and some

static problems. Therefore it is decided that the house will be retrofitted.

2. Design and construction of the house

At the beginning in 1985, the house was designed and built as a one-storey house with concrete foundation standing directly on the ground. Crawl space is underneath the house inside the concrete foundation.

Wooden structure with mineral wool insulation encloses a building area of 109m², including an entrance hall, a living room, a kitchen, a bathroom, a utility room and 3 bedrooms (figure 1, 2, 3). Afterwards the house has been reconstructed. A whole storey was added inside the crawl space and therefore the house has a basement. On the original ground floor, a bedroom was changed to hold a staircase and in the basement a technical room, new bedrooms, storage and a study were added (figure 3, 4).



Figure 3: The current view of the blue house with the basement

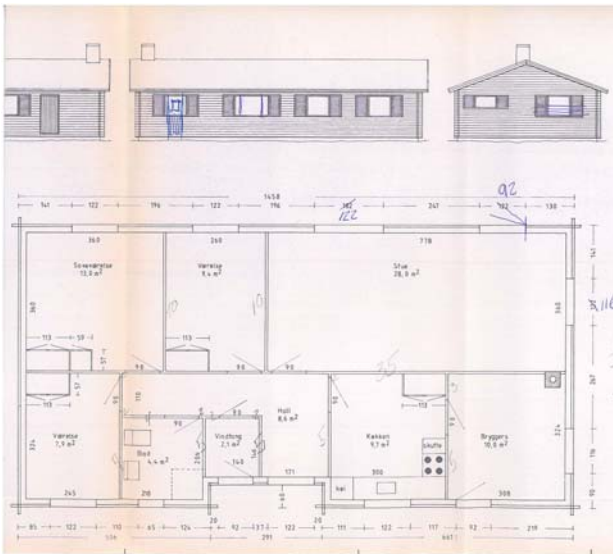

Figure 1: Original plan and façades of the blue house

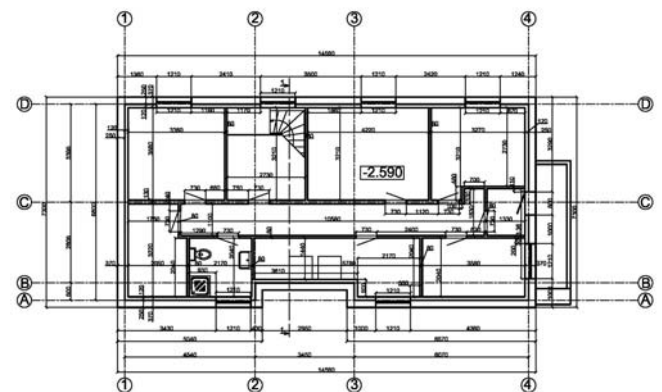

Figure 4: The plan of the basement

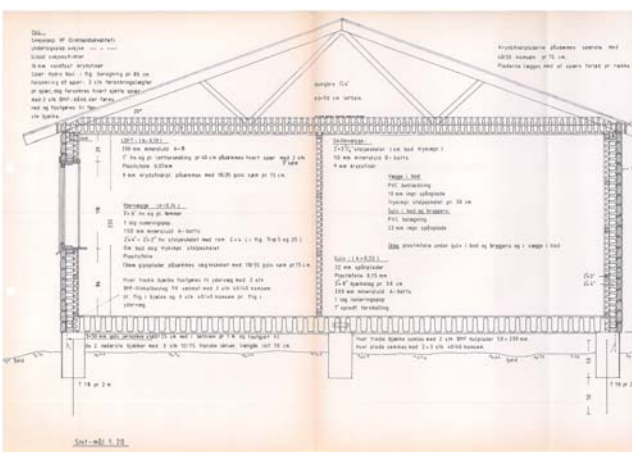

Figure 2: Original cross-section of the blue house

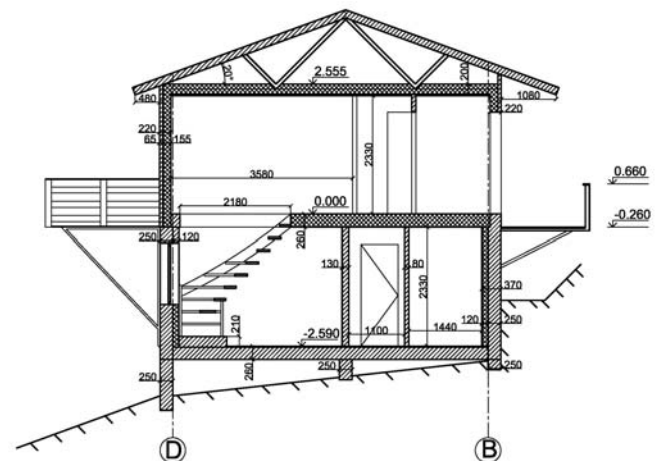

Figure 5: The cross-section (current situation)

The construction of the exterior walls of the ground floor is wooden structure with 150mm mineral wool insulation inside.

13mm gypsum board is used on the interior side (figure 6). The construction of the ground floor is wooden structure with 200mm mineral wool insulation. The exterior walls of the basement consists of 250mm concrete, 80mm insulation, air gap and 1-2 layers of gypsum board. The total thickness is 370mm. The basement floor is built with concrete with interior insulation. Self-carrying roof structure with 200mm mineral wool insulation is used for the pitched roof, which has an inclination of 20°.

Wooden insulated exterior doors and wooden-frame double glazing windows are used for the house.

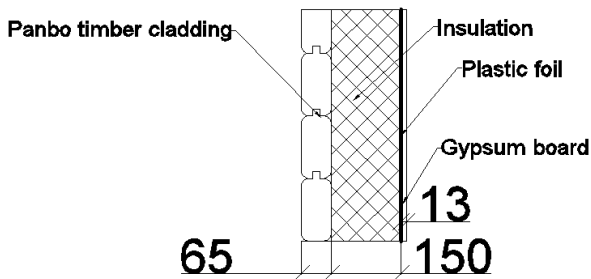

Figure 6: The construction of the exterior wall (ground floor)

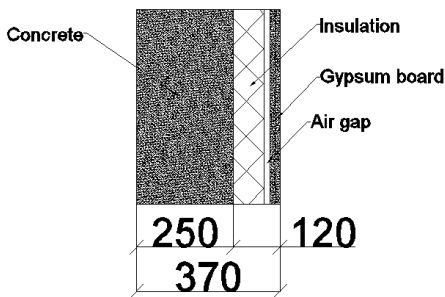

Figure 7: The construction of the exterior wall (basement)

3. Indoor environment measurement

Since December 7, 2010, 4 sensors have been measuring and logging the indoor temperature and relative humidity. 1 sensor has been used to measure exterior temperature and relative humidity. The temperature and relative humidity of the

coldest and the warmest week are taken as examples (figure 8, 9, 10, 11).

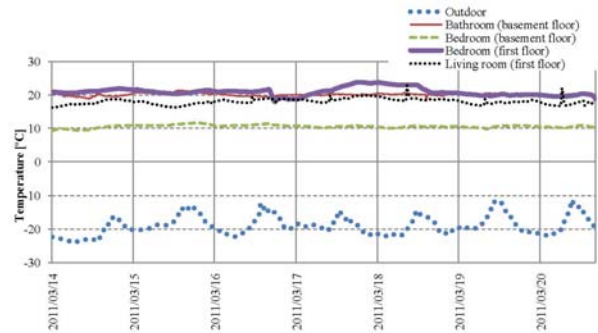

Figure 8: Measured temperature in the coldest week of 2011

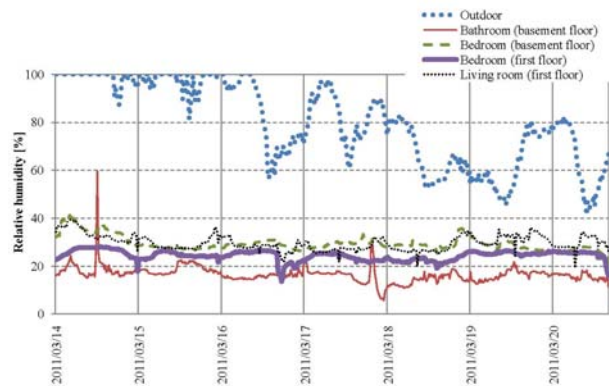

Figure 9: Measured relative humidity in the coldest week of 2011

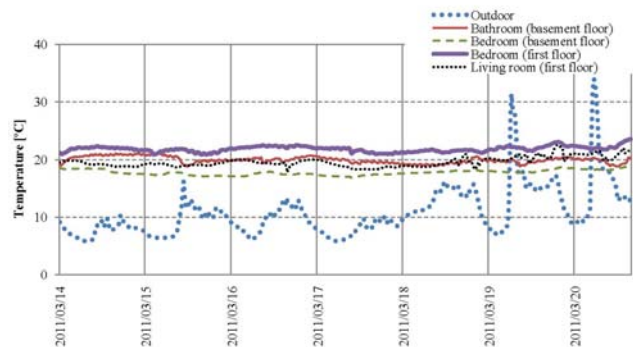

Figure 10: Measured temperature in the warmest week of 2011

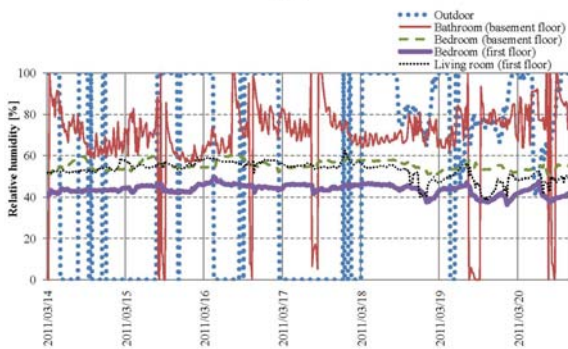

Figure 11: Measured relative humidity in the warmest week of 2011

The figures show that in the summer the house does not have a problem of overheating. In the winter the bedroom in the basement is probably not used because the temperature of the bedroom is around 10°C. But in the warmest week of 2011 the measure relative humidity often reaches 100% and it might show a malfunction of the sensors. In addition, there are also some problems with where the sensors are placed. The sensors are placed too close to the floor. However ideal position should be between 1m and 2m on the wall. Therefore the results of the TinyTags measurement could be taken for reference but in the future the sensors should be replaced and more precise results would be used to analyze the indoor climate.

4. Blower-door test and thermography

4.1 Result and analysis of blower-door test

Blower-door test was used to measure the air change rate through the building envelope of the blue house. The equipment used is RETROTEC 2000 DOOR FAN with digital gauge DM-2 together with software Door Fan 3.0 Enclosure Leakage Analysis Software (version 3.247).

The initial data and boundary conditions of the blower door tests carried out for the blue house are shown in table 1. 12 steps ranging from 10 pa to 60 pa with each step of 4.2 pa were used during the tests. 4 sets of tests were performed, including both 2

sets of pressurization and depressurization using method A and the same using method B. For method A all vents in the house were only closed, and for method B all vents were sealed and taped over as in accordance with EN 13829.

Table 1 Initial data and boundary conditions for the blower-door tests

Initial data		Boundary conditions	
Net floor area A_{net}	183.76 m ²	Interior temperature	22.8 °C
Internal surface area A_E	382 m ²	Outside temperature	14.0 °C
Internal Volume V	453.89 m ³	Wind speed	5m/s
Elevation	37 m	Weather	sunny

The measured results from the blower door test using method A and method B are shown in table 2 and table 3.

Table 2 Results from the blower-door test (Method A)

Data	Symbol	Result for 'Method A'			Unit
		Depressurize	Pressurize	Average	
Airflow at 50 Pa	V_{50}	469.0	479.0	474.0	l/s
Air change at 50 Pa	n_{50}	3.72	3.80	3.76	h ⁻¹
Permeability at 50 Pa	q_{50}	1.23	1.25	1.24	l/s/m ²
Specific leakage rate at 50 Pa	W_{50}	2.55	2.61	2.58	l/s/m ²

Table 3 Results from the blower-door test (Method B)

Data	Symbol	Result for 'Method B'			Unit
		Depressurize	Pressurize	Average	
Airflow at 50 Pa	V_{50}	386.0	401.0	393.5	l/s
Air change at 50 Pa	n_{50}	3.06	3.18	3.12	h ⁻¹
Permeability at 50 Pa	q_{50}	1.01	1.05	1.03	l/s/m ²
Specific leakage rate at 50 Pa	W_{50}	2.10	2.18	2.14	l/s/m ²

The results of air tightness of the building envelope show that the blue house fulfils the Danish Standard request where the air permeability, or respectively q_{50} at 50 Pa pressure difference, must be below 1.5 l/s/m^2 (DBR, 2008). The air change rate at 50 Pa of the Blue House is approximately $n_{50} = 3.1 \text{ h}^{-1}$. Comparing with the standard wooden family houses in Greenland built in 1960s which have the air tightness varying from $n_{50} = 11.3 - 18.5 \text{ h}^{-1}$, the blue house presents a higher quality of younger buildings in Greenland. In comparison to a newly built Low-energy house in Sisimiut with mechanical ventilation system with $n_{50} = 3.1 \text{ h}^{-1}$, the blue house represents a good example of a house with natural ventilation system.

4.2 Result and analysis of thermography test

Thermography test was used for detection of the irregularities in the building structure and the detection of surface temperatures of the blue house. The testing equipment used for performing a thermography test was an infrared camera HotFind-D and digital camera. The results were evaluated using ThermoView software and were evaluated in accordance with EN 13187.

Two thermography tests were performed of the interior of the house with depressurizing of 50 Pa and of the exterior of the house with neutral pressure. The boundary conditions for both tests are listed in Table 4.

Table 4

Elements	Thermography from inside	Thermography from outside
Interior temperature	22.8 °C	22.0 °C
Outside temperature	14.0 °C	5.0 °C
Wind speed	5m/s	-
Weather – current	Sunny	At night
Weather – 12 prior	Sunny	Cloudy
Temperature difference	8.8 °C, not OK	17.0 °C, OK

The thermography tests show that there are some problems with the building envelope, such as leaky windows, doors and building component joints. Some pictures are taken as examples to see the problems. (Figure 12, 13 and 14)



Figure 12: The leaking balcony door in the living room

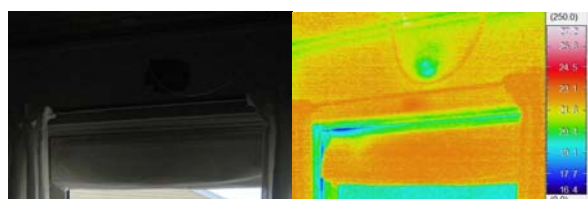

Figure 13: Untight window, natural vent and joints between the wall and the ceiling



Figure 14: A comparison between a picture of the west façade of the house and the thermographic picture of the west façade

From the thermography tests it can be seen that although the building envelope of the blue house is rather tight, the house has many weak points. Except for the problematic windows, doors, natural vents and some joints between building components, the heat loss through the building envelope of the ground floor (wood) differs from heat lost through the envelope of the basement (concrete). The result of the testing reveals that heat loss through the thermally weak parts could be quite high. It means in the retrofitting, improvement of the wind barrier and continualization of the whole building envelope must be considered.

5. Retrofitting proposal

According to the result of the investigation, the retrofitting work mainly consists of applying extra paper insulation layer and new climate shield, replacement of windows and doors, levelling up the living room floor and installation of mechanical ventilation system.

'Thermal Bridge Breaker (TBB)' will be used to fix the new wind barrier and climate shield, at the meantime it will make room for the paper insulation (figure 15). TBB 80mm height will be mounted every 450mm vertical and horizontal. To the exterior Cembritt windstopper 9mm, additional wooden board and new climate shield will be used. 105mm Paper insulation for the wooden walls and 120mm for the concrete walls will be blown behind the windstopper through a pipe. To protect the paper insulation from the moisture, 100mm EPS board will be installed at the lower part of the outer walls where the walls touch the ground. Except for the outer walls, the attic and the basement floor will also be insulated with additional paper insulation.

Fiberline profiles 120mm x 120mm will be used to fix the current balcony and catwalk and to stabilize the new windshield.

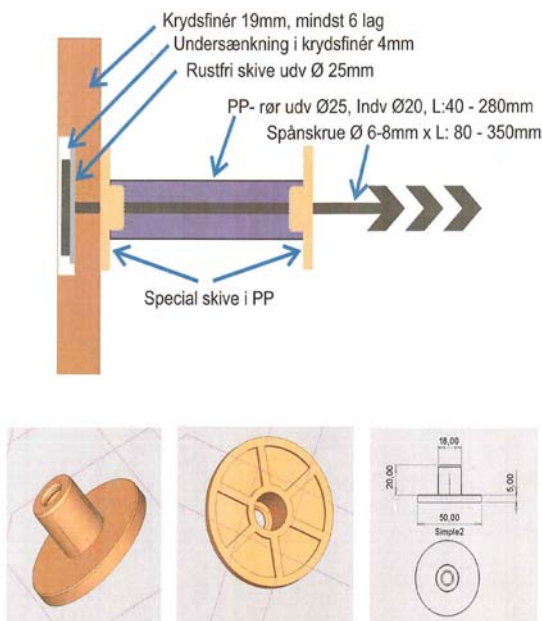

Figure 15: The Thermal Bridge Breaker

6. Conclusions

The thickness of the paper insulation will be further discussed according to energy analysis and calculation. The actual energy consumption will be monitored after the house is retrofitted.

The performance of the additional paper insulation should be measured using a simple online system with in-built sensors which should monitor temperature, dew point and humidity at the different levels of the paper insulation, e.g. between current outer surface of the concrete and new additional layer of the insulation; also the same for current wooden part and new additional paper insulation; around windows, etc.

Furthermore, continuous collection of measured data in the blue house (temperature, relative humidity, oil bill, questionnaires, etc.) to ensure the further documentation of energy savings achieved by application of the paper insulation and the mechanical ventilation system in the blue house will be carried out to further investigate the energy saving effect of the whole retrofitting plan.

Considering the huge amount of existing buildings that need to be improved in Greenland, the experiences from the Blue House project could be used for reference for other Greenlandic buildings.

Acknowledgements

The gratitude is expressed to the inhabitants, the Olsen family for their support during the whole measurement and cooperation with the questionnaire. Thanks to Poul Linnert Christensen, Ulvis Silins, Sandijs Vasilevskis and Martin Kotol for participating in the measurement. Special thanks to Ole Villumsen for his help with the investigation. The 'Blue House' Project is part of the Northern Periphery Programme project 'Natural Energy Efficiency and

Sustainability (NEES)' of ARTEK, Technical University of Denmark.

References

Bjarløv, S.P., Vladykova, P. (2011): The potential and need for energy saving in standard family detached and semi-detached wooden houses in arctic Greenland, *Building and Environment*, Vol. 46, pp. 1525-1536.

Vladykova, Petra, Qu, Jing (2011): Initial Investigation of the Blue House, Internal Report of Department of Civil Engineering, Technical University of Denmark.