

Loop transfer recovery for general observer architecture

Niemann, Hans Henrik; Søgaard-Andersen, Per ; Stoustrup, Jakob

Published in:
International Journal of Control

Publication date:
1991

Document Version
Publisher's PDF, also known as Version of record

[Link back to DTU Orbit](#)

Citation (APA):
Niemann, H. H., Søgaard-Andersen, P., & Stoustrup, J. (1991). Loop transfer recovery for general observer architecture. *International Journal of Control*, 53(5), 1177-1203.

DTU Library

Technical Information Center of Denmark

General rights

Copyright and moral rights for the publications made accessible in the public portal are retained by the authors and/or other copyright owners and it is a condition of accessing publications that users recognise and abide by the legal requirements associated with these rights.

- Users may download and print one copy of any publication from the public portal for the purpose of private study or research.
- You may not further distribute the material or use it for any profit-making activity or commercial gain
- You may freely distribute the URL identifying the publication in the public portal

If you believe that this document breaches copyright please contact us providing details, and we will remove access to the work immediately and investigate your claim.

Loop transfer recovery for general observer architectures

HANS HENRIK NIEMANN†, PER SØGAARD-ANDERSEN‡
and JAKOB STOUSTRUP§

A general and concise formulation is given of the loop transfer recovery (LTR) design problem based on recovery errors. Three types of recovery errors are treated: open loop recovery, sensitivity recovery and input-output recovery errors. The three corresponding versions of the asymptotic recovery problem turn out to be equivalent, since the minimization of the recovery errors all amount to the minimization of a certain matrix, the recovery matrix. Using the recovery error definitions, simple necessary and sufficient conditions for the controllers are derived both for the exact and asymptotic recovery cases. This general recovery formulation covers all known observer based compensator types as special cases. The conditions given in this setting are effectively the aim of all known LTR design methods. The recovery formulation is interpreted in terms of a model-matching problem as well, which is examined by means of the Q -parametrization. It is shown how the general controller obtained by the Q -parametrization can be written as a Luenberger observer based controller. In all cases, n controller states suffice to achieve recovery. The compensators are characterized for errors both on the input- and on the output-node (dual case).

1. Introduction

In the last decade, the concept of loop transfer recovery (LTR) has emerged as an important approach to the design of robust feedback controllers. The attractive theoretical properties of such controllers in combination with their conceptual and computational simplicity has motivated their popularity and spread in the control community (see Athans 1986, Dowdle 1979, Doyle and Stein 1979, 1981, Goodman 1984, Saberi and Sannuti 1988, Stein and Athans 1987, and Søgaard-Andersen 1986 for continuous time systems and Dowdle 1979, Goodman 1984, Maciejowski 1985 and Niemann and Søgaard-Andersen 1988 for discrete time systems). Yet the methodology suffers from several drawbacks.

In the usual LTR-setting, design rules are developed based on *sufficient* conditions for recovery only. A consequence of this is that the design rules might not necessarily point out the 'best' controller from an LTR point of view.

Another drawback lies in the assumed controller structure in previous approaches. Thus, it has not been investigated if different choices of controller types would yield better general performance, or, conversely, which special performance properties are associated with the different classes of compensators.

A third drawback is the lack of effective design rules for non-minimum phase plants. Some design results have been outlined by Niemann and Jannerup (1990),

Received 20 May 1990. Revised 16 October 1990.

† Institute of Automatic Control Systems, Technical University of Denmark, Building 326, DK-2800, Lyngby, Denmark.

‡ SimCorp A/S, Kompagnistræde 20, DK-1208 København K, Denmark.

§ Mathematical Institute, Technical University of Denmark, Building 303, DK-2800 Lyngby, Denmark.

Stein and Athans (1987), and Zhang and Freudenberg (1990), but no general results have been available.

Yet another drawback in the usual setting has been the 'unsystematic' nature of the recovery design step. Typically, certain design parameters (e.g. quadratic weights, eigenvalues, or the like) are adjusted until 'reasonable' recovery is achieved. The adjustment procedure is, hence, rather *ad hoc*, and no algorithms are available for the fine tuning. The only result in this connection is the fact that arbitrarily good recovery is achieved in the limit for minimum phase plants under certain assumptions.

The purpose of this paper is to present some of the previous approaches in a survey form, as well as to overcome some of their limitations.

Based on the concept of recovery errors (originally introduced by Goodman 1984) we derive necessary and sufficient conditions for the controller parameters to obtain LTR. These conditions are formulated for observers satisfying the Luenberger conditions, which actually apply to *all* stabilizing compensators (see below). It turns out that a certain matrix, which we shall call the recovery matrix, plays a fundamental role in the LTR-problem. Independently of the way the recovery problem has been formulated, asymptotic LTR becomes equivalent to minimizing the norm of this matrix.

Thereafter we show how these results can be specialized into the well-known results for full and minimal order observers, and further we derive new strong results for PI-observers (both full and minimal order).

More importantly, however, we use these necessary and sufficient conditions to develop a much more general formulation of the recovery problem. By augmenting the standard full state observer architecture with an additional dynamical feedback structure attached at the estimation error node, we parametrize all possible compensators which internally stabilize the closed loop system in the LTR context. The structure thus obtained can be interpreted in terms of a model-matching problem. It is possible to eliminate the n superfluous states introduced in this way by a merging technique as described by Niemann *et al.* (1990 b).

The remainder of this paper is organized as follows.

In § 2 the necessary and sufficient conditions for LTR are derived for the Luenberger observer. In § 3 these conditions are specialized to a number of well-known observer architectures, and the most general controller structure, the Youla-parametrized controller, is shown to be a Luenberger observer based controller as well. The minimization of the associated recovery matrix is shown to be a model-matching problem in the Youla parameter. The solution to this model-matching problem is given by some recent results. Section 4 treats the dual case. Finally, some concluding remarks are given.

2. General LTR-conditions

In this chapter we describe the significance of LTR and give a brief introduction to the Luenberger observer. Thereafter, necessary and sufficient conditions for achieving recovery are derived for the general Luenberger observer.

2.1. Significance of loop transfer recovery

Loop transfer recovery is a tool applied in robust multivariable control. LTR-design is the last step in a three step design procedure for constructing dynamic

compensators. The first step in this procedure is a specification of the desired properties for the final feedback control system. The second step is the design of the target loop, using a *state feedback*, for which the specifications are satisfied, followed by the LTR step, in which the target loop is 'recovered' by an *admissible* measurement based compensator.

To apply LTR in robust control, suppose the robust stability and nominal performance specifications are posed in the frequency domain via singular value inequalities. In this paper, these specifications are primarily reflected back to the plant input. Let the nominal plant be denoted by $\mathbf{G}(s)$, and let the true plant be $\mathbf{G}_a(s)$. The sensitivity and the complementary sensitivity functions for the plant input node are denoted by $\mathbf{S}(s)$ and $\mathbf{T}(s)$. Then,

$$\left. \begin{aligned} \mathbf{G}_a(s) &= \mathbf{G}(s)[1 + \Delta(s)], \quad s = j\omega \\ \bar{\sigma}[\Delta(j\omega)] &\equiv l(j\omega) \end{aligned} \right\} \quad (2.1)$$

Details of this assumption and some consequences thereof have been discussed by Doyle and Stein (1981). The specifications can now be posed as

$$\left. \begin{aligned} \bar{\sigma}[\mathbf{S}(j\omega)] &< p(j\omega) \\ \bar{\sigma}[\mathbf{T}(j\omega)] &< 1/l(j\omega) \end{aligned} \right\} \quad (2.2)$$

where $p(\cdot)$ is some weight on the sensitivity functions which reflects the performance specifications (e.g. asymptotic tracking, bandwidth), and $l(\cdot)$ is the uncertainty bound.

If the controller is a model-based compensator, a systematic procedure has been derived for satisfying the constraints (2.2). First, a full-state design which satisfies (2.2) is designed (see Athans 1986, Stein and Athans 1987, Søgaard-Andersen 1986). This design is then recovered systematically for each frequency. Normally, the system is assumed to be minimum phase (which, as shown later in this paper, guarantees asymptotic recovery), i.e. the recovery can be arbitrarily well approximated at all frequencies.

Note that the specifications might also have been stated for the plant output node. The results in this paper facilitate both formulations of the specifications—although only details of the first type are given, whereas results for the plant output node are summarized at the end of the paper.

At this point we should stress that the state feedback design can be performed completely independently of the specific LTR procedure chosen. For non-minimum phase systems, though, it might in special cases be convenient to choose a state feedback with certain given properties (see Niemann *et al.* 1990 b).

2.2. Luenberger observer

Let the FDLTI plant model Σ be represented by a minimal state-space realization $(\mathbf{A}, \mathbf{B}, \mathbf{C})$:

$$\Sigma: \begin{cases} \dot{\mathbf{x}} = \mathbf{A}\mathbf{x} + \mathbf{B}\mathbf{u}, & \mathbf{x} \in \mathbb{R}^n, \mathbf{u} \in \mathbb{R}^r \\ \mathbf{y} = \mathbf{C}\mathbf{x}, & \mathbf{y} \in \mathbb{R}^m \end{cases} \quad (2.3)$$

with $m \geq r$, $n > m$, (\mathbf{C}, \mathbf{A}) observable and \mathbf{C}, \mathbf{B} of full rank.

Now let the plant be controlled by an observer-based compensator containing a state feedback

$$\mathbf{u} = -\mathbf{K}\hat{\mathbf{x}} + \mathbf{r} = \mathbf{r} - \mathbf{w} \quad (2.4)$$

2.3. Recovery types and LTR conditions

The loop transfer recovery (LTR) design method (see Athans 1986, Doyle and Stein 1979, 1981, Stein and Athans 1987) is now applied to the compensator. In order to formulate the loop-shape robustness constraints the uncertainties (disturbances, noise and modelling errors) are reflected back to the plant input node (see Goodman 1984, Stein and Athans 1987). The target loop transfer is then the full-state loop transfer $\mathbf{G}_{\text{TFL}}(s)$:

$$\mathbf{G}_{\text{TFL}}(s) = \mathbf{K}\Phi(s)\mathbf{B} \quad (2.11)$$

where \mathbf{K} is the target design and the full loop transfer is $\mathbf{G}_1(s)$ (see Athans 1986, Stein and Athans 1987):

$$\begin{aligned} \mathbf{G}_1(s) &= \mathbf{C}(s)\mathbf{G}(s) \\ &= \mathbf{V}\mathbf{C}\Phi(s)\mathbf{B} + \mathbf{P}(s\mathbf{I} - \mathbf{D} + \mathbf{G}\mathbf{P})^{-1}(\mathbf{E} - \mathbf{G}\mathbf{V})\mathbf{C}\Phi(s)\mathbf{B} \end{aligned} \quad (2.12)$$

The difference between the target and the full loop transfer is defined as the loop recovery error $\mathbf{E}_1(s)$ at the input loop breaking point:

$$\mathbf{E}_1(s) = \mathbf{K}\Phi(s)\mathbf{B} - \mathbf{C}(s)\mathbf{G}(s) \quad (2.13)$$

The recovery error was first introduced by Goodman (1984) for full-order observer based compensators. It is now possible to rewrite the recovery error $\mathbf{E}_1(s)$ into a more convenient form, as follows.

Lemma 1

Define

$$\mathbf{M}_1(s) = \mathbf{P}(s\mathbf{I} - \mathbf{D})^{-1}\mathbf{G} \quad (2.14)$$

Then

$$\mathbf{E}_1(s) = \mathbf{M}_1(s)(\mathbf{I} + \mathbf{M}_1(s))^{-1}(\mathbf{I} + \mathbf{G}_{\text{TFL}}(s)) \quad (2.15)$$

The proof of Lemma 1 is given in Appendix A.

The matrix-valued function \mathbf{M}_1 turns out to be of great significance in what follows. It describes the mismatch between the actual and the desired transfer function. Therefore we will refer to \mathbf{M}_1 as the *recovery matrix* for the plant input node.

However, when the plant $\mathbf{G}(s)$ is unstable, the recovery error transfer function $\mathbf{E}_1(s)$ will also be an unstable transfer function. Instead of using open-loop transfer functions, the recovery error can be defined in an equivalent way in terms of the sensitivity functions. Let the sensitivity recovery error at the plant input-loop breaking point be defined as

$$\mathbf{E}_{\text{S},1}(s) = \mathbf{S}_{\text{TFL}}(s) - \mathbf{S}_1(s) \quad (2.16)$$

where

$$\mathbf{S}_{\text{TFL}}(s) = (\mathbf{I} + \mathbf{G}_{\text{TFL}}(s))^{-1} \quad \text{and} \quad \mathbf{S}_1(s) = (\mathbf{I} + \mathbf{G}_1(s))^{-1}$$

Both the target and the full-loop sensitivity functions are stable, which implies that the sensitivity recovery error transfer function $\mathbf{E}_{\text{S},1}(s)$ is stable.

The power of \mathbf{M}_1 is indicated by the following two lemmas.

Lemma 1

With \mathbf{M}_1 as above, $\mathbf{E}_{S,1}(s)$ becomes:

$$\mathbf{E}_{S,1}(s) = -\mathbf{S}_{\text{TFL}}(s)\mathbf{M}_1(s) \quad (2.17)$$

For the proof, see Appendix A or Sogaard-Andersen and Niemann (1989).

The recovery problem has in a simple way been formulated as a sensitivity recovery problem in Lemma 2 by means of the recovery matrix from the original formulation in Lemma 1.

The third type of recovery we define is input-output recovery (IO recovery). In this case, we look at the closed-loop transfer functions between input \mathbf{r} and output \mathbf{y} in the control feedback system. The IO recovery error is defined at the plant input-loop breaking point as

$$\begin{aligned} \mathbf{E}_{\text{IO},1}(s) &= \mathbf{G}_{\text{T,cl}}(s) - \mathbf{G}_{\text{I,cl}}(s) & (2.18) \\ \mathbf{G}_{\text{T,cl}}(s) &= \mathbf{C}(s\mathbf{I} - \mathbf{A} + \mathbf{BK})^{-1}\mathbf{B} \\ \mathbf{G}_{\text{I,cl}}(s) &= (\mathbf{I} + \mathbf{C}\Phi(s)\mathbf{B}\mathbf{C}(s))^{-1}\mathbf{C}\Phi(s)\mathbf{B} \end{aligned}$$

Again the introduction of \mathbf{M}_1 simplifies the expression, as follows.

Lemma 3

With \mathbf{M}_1 as above, $\mathbf{E}_{\text{IO},1}(s)$ becomes

$$\begin{aligned} \mathbf{E}_{\text{IO},1}(s) &= -\mathbf{C}\Phi(s)\mathbf{B}\mathbf{S}_{\text{TFL}}(s)\mathbf{M}_1(s) \\ &= -\mathbf{G}_{\text{T,cl}}(s)\mathbf{M}_1(s) \end{aligned} \quad (2.19)$$

Lemma 3 follows from Lemma 2.

By these three formulations of the recovery problem in Lemmas 1, 2 and 3 the very useful recovery matrix \mathbf{M}_1 has been introduced. Most of the analysis in the rest of this paper is based on this recovery matrix, owing to the results in the following theorem.

By recovery in the rest of this paper we mean sensitivity recovery as defined by Lemma 2, if nothing else is declared.

Let us look at the condition for achieving exact recovery, which is achieved if $\mathbf{S}_{\text{TFL}}(s) = \mathbf{S}_1(s)$. This implies that the recovery error given in (2.16) or (2.17) must be zero. Based on this result, it is possible to give four equivalent descriptions of the event of exact recovery, as follows.

Theorem 1

Exact recovery is obtained if and only if one of the following equivalent conditions holds:

$$\left. \begin{aligned} \text{(i)} & \quad \mathbf{E}_{S,1}(s) = 0 \\ \text{(ii)} & \quad \mathbf{M}_1(s) = 0 \\ \text{(iii)} & \quad \langle \mathbf{D}, \text{Im } \mathbf{G} \rangle \subset \ker \mathbf{P} \end{aligned} \right\} \quad (2.20)$$

If we assume that \mathbf{D} is non-defective, all of these are equivalent to

$$\text{(iv)} \quad \mathbf{P}\mathbf{v}_i = 0 \vee \mathbf{w}_i^T \mathbf{G} = 0, \quad \text{for } i = 1, \dots, p$$

where \mathbf{v}_i and \mathbf{w}_i^T are right and left eigenvectors, respectively, associated with the eigenvalue λ_i of \mathbf{D} , $p = \dim \mathbf{D}$.

Theorem 1 is proved in Appendix B.

The third condition in Theorem 1 can be checked very easily (see Appendix B). The conditions (iii) and (iv) are given in terms of the Luenberger parameters, rather than in the system data. Hence, the theorem provides a necessary and sufficient test which a given controller has to satisfy to solve the exact recovery problem; so, in the present form these conditions are not so interesting from an applied point of view. To derive easily checkable conditions for direct solvability in the system data, one has to exploit the structure of the desired controller architecture. This has been done in § 3 for full-order and minimal-order observer based controllers. In general, the conditions might look very different for the various controller architectures.

Only in rather special cases, however, will it be possible to achieve exact recovery with a free target design \mathbf{K} , see § 3.2. Therefore the conditions in Theorem 2.1 do not have a great significance of their own. But, as appears in what follows, these conditions generalize within the framework of *asymptotic* recovery and become the basis for this.

Asymptotic recovery is defined as follows.

Definition 1

Asymptotic recovery is said to be achievable if and only if for all $\varepsilon > 0$ there exists a controller $\mathbf{C}_\varepsilon(s)$ such that

$$\|\mathbf{S}_{\text{TFL}}(\cdot) - \mathbf{S}_{\text{I},\varepsilon}(\cdot)\|_{\text{H}} < \varepsilon \quad (2.21)$$

where $\mathbf{S}_{\text{I},\varepsilon}(\cdot)$ is the closed loop sensitivity function corresponding to $\mathbf{C}_\varepsilon(s)$, and $\|\cdot\|_{\text{H}}$ is a suitable norm.

The possible choices of the norm $\|\cdot\|_{\text{H}}$ are numerous, and should in principle reflect the application. Note, though, that if asymptotic recovery is possible in any norm it is achievable in (almost) any other norm as well, since as ε tends to zero, there has to exist a sequence of controllers that makes the error tend uniformly to zero. Nevertheless, from an applied point of view the norm involved is not unimportant, since the control objective whenever asymptotic recovery is possible would typically be to satisfy a norm bound which 'suffices' and is attainable with acceptable gains. An important special choice of norm is the \mathcal{H}_∞ norm. Niemann *et al.* (1990 b) have dealt with \mathcal{H}_∞ guaranteed norm bounds for the asymptotic recovery problem, as well as for the general non-minimum phase case. Non-iterative procedures to fulfil the norm bounds were provided.

The following is an immediate consequence of Lemma 2:

Corollary 1

Asymptotic recovery is possible if and only if for all $\varepsilon > 0$ there exists a controller $\mathbf{C}_\varepsilon(s)$ such that

$$\|\mathbf{M}_{\text{I},\varepsilon}(\cdot)\|_{\text{H}} < \varepsilon \quad (2.22)$$

where $\mathbf{M}_{\text{I},\varepsilon}(\cdot)$ is the recovery matrix corresponding to $\mathbf{C}_\varepsilon(s)$.

In terms of the system data, solvability of the asymptotic recovery problem can be expressed by means of the almost controlled invariant subspace $\mathcal{V}_{b,g}^*(\Sigma_F)$ (see e.g. Trentelman 1986) associated with the following auxiliary system:

$$\Sigma_F: \begin{cases} \dot{\mathbf{x}} = \mathbf{A}^T \mathbf{x} - \mathbf{C}^T \mathbf{u} + \mathbf{K}^T \mathbf{w} \\ \mathbf{z} = \mathbf{B}^T \mathbf{x} \end{cases}$$

In this notation we have the following result.

Theorem 2

Asymptotic recovery can be achieved for the system $\Sigma: (\mathbf{A}, \mathbf{B}, \mathbf{C})$ if and only if the inclusion $\text{Im } \mathbf{K}^T \subset \mathcal{V}_{b,g}^*(\Sigma_F)$ holds.

The theorem has been proved by Niemann *et al.* (1990 a).

The necessary and sufficient condition for asymptotic recovery given by Theorem 2 is easily checked by the subspace algorithms given by Trentelman (1986).

At last, the recovery matrix is not just an abstract matrix which should be minimized for achieving recovery, but \mathbf{M}_I really exists as an open loop transfer function in the compensator. To show this, let us look at the signal \mathbf{u}' as function of the input signal \mathbf{u} and the output signal \mathbf{y} (see Fig. 1). The signal \mathbf{u}' inside the compensator is given by

$$\left. \begin{aligned} \mathbf{u}'(s) &= \mathbf{M}_I(s)\mathbf{u}(s) + \mathbf{N}_I(s)\mathbf{y}(s) \\ \mathbf{N}_I(s) &= \mathbf{V} + \mathbf{P}(s\mathbf{I} - \mathbf{D})^{-1}\mathbf{E} \end{aligned} \right\} \quad (2.23)$$

Using (2.23), Fig. 1 then takes the form shown in Fig. 2. This form can be interpreted as the compensator transformed into what could be called the *recovery form*.

This formulation shows that the physical effect in the compensator by achieving recovery is that the coupling between \mathbf{u} and \mathbf{u}' will be minimized. The same observer-form has been described by Kailath (1980) in connection with a coprime factorization of full-order observers.

3. LTR conditions for specific observer types

The conditions for achieving recovery based on the recovery matrix \mathbf{M}_I derived in § 2.3 will be used on compensators based on different observer types of the Luenberger type.

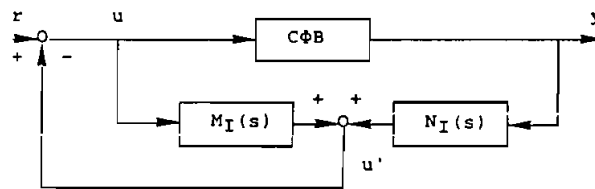

Figure 2. Feedback system in the recovery form.

3.1. Full-order observer

The full-order observer is the most used observer type and is included in the Luenberger observer. The full-order observer appears from the Luenberger observer by the following selection of the matrices in (2.5) (Luenberger 1971, O'Reilly 1983):

$$\left. \begin{aligned} \mathbf{D} &= \mathbf{A} - \mathbf{FC} \\ \mathbf{G} &= \mathbf{B} \\ \mathbf{P} &= \mathbf{K} \\ \mathbf{E} &= \mathbf{F} \\ \mathbf{V} &= \mathbf{0} \\ \mathbf{T} &= \mathbf{I} \end{aligned} \right\} \quad (3.1)$$

where \mathbf{F} is the observer gain matrix.

Based on these matrices, the recovery matrix is given by

$$\mathbf{M}_1(s) = \mathbf{K}(s\mathbf{I} - \mathbf{A} + \mathbf{FC})^{-1}\mathbf{B} \quad (3.2)$$

This result was first found by Goodman (1984) and later used by Sogaard-Andersen and Niemann (1989).

To formulate the next result, we need to consider the auxiliary system

$$\Sigma_F: \begin{cases} \dot{\mathbf{x}} = \mathbf{A}^T\mathbf{x} - \mathbf{C}^T\mathbf{u} + \mathbf{K}^T\mathbf{w} \\ \mathbf{z} = \mathbf{B}^T\mathbf{x} \end{cases}$$

By $\mathcal{V}^*(\Sigma_F)$ we denote the supremal controlled invariant subspace (see Wonham (1985) for this auxiliary system. Now we have the following result.

Lemma 4

Exact recovery is possible by the above full-order observer if and only if one of the following three conditions is satisfied:

$$\left. \begin{aligned} \text{(i)} & \quad \mathbf{M}_1(s) = 0 \\ \text{(ii)} & \quad \langle \mathbf{A} - \mathbf{FC} \mid \text{Im } \mathbf{B} \rangle \subset \ker \mathbf{K} \\ \text{(iii)} & \quad \text{Im } \mathbf{K}^T \subset \mathcal{V}^*(\Sigma_F) \end{aligned} \right\} \quad (3.3)$$

Conditions (i) and (ii) are immediate from Theorem 1. Condition (iii) follows from condition (ii) by applying Theorem 4.2 of Wonham (1985). The constructive solution to the exact disturbance decoupling problem of Wonham (1985) can be applied to solve the exact LTR problem. An explicit LTR design method for achieving exact recovery based on condition (iv) in Theorem 1 has been derived by Sogaard-Andersen (1987 a).

However, exact recovery cannot in general be achieved by observer design. Instead, asymptotic recovery might be obtained by a suitable parametrization of the observer gain, $\mathbf{F} = \mathbf{F}(q)$, $q \in \mathbb{R}^+$ such that

$$\|\mathbf{M}_1(j\omega)\| \rightarrow 0 \quad \forall \omega, \text{ as } q \rightarrow \infty \quad (3.4)$$

A sufficient condition on $\mathbf{F}(q)$ for obtaining asymptotic recovery was first given by Doyle and Stein (1979, 1981), as follows. If

$$\frac{\mathbf{F}(q)}{q} \rightarrow \mathbf{B}\mathbf{W} \quad \text{for } q \rightarrow \infty \quad (3.5)$$

where $\det \mathbf{W} \neq 0$, we achieve asymptotic recovery, i.e. $\mathbf{M}_1 \rightarrow 0$ for $q \rightarrow \infty$, provided $(\mathbf{A}, \mathbf{B}, \mathbf{C})$ is minimum phase. Observer gains which satisfy the asymptotic recovery condition in (3.5) can be designed by using LQG with suitable selections of the weight matrices (see Athans 1986, Dowdle 1979, Goodman 1984, Stein and Athans 1987, Sogaard-Andersen 1986) or by using eigenstructure assignment (see Sogaard-Andersen 1986, 1989). Later, the sufficient condition on \mathbf{F} was relaxed by Matson and Maybeck (1987) for square plants and by Saberi and Sannuti (1988) for left invertible plants.

Asymptotic recovery is normally impossible for non-minimum phase plants (see Niemann *et al.* 1990 b). The recovery matrix will converge to a non-zero matrix function, $\mathbf{M}_{1,\text{RHP}}$, when the LTR design method is applied to non-minimum phase systems. Explicit expressions for this non-zero function can be found in the work of Niemann and Jannerup (1990), Sogaard-Andersen and Niemann (1989) and Zhang and Freudenberg (1990). $\mathbf{M}_{1,\text{RHP}}$ turns out to be dependent on both the target design and the RHP zeros $(\mathbf{A}, \mathbf{B}, \mathbf{C})$.

3.2. Minimal-order observer

The general LTR condition developed in § 2.3 is now related to the minimal-order observer.

First, let the plant $(\mathbf{A}, \mathbf{B}, \mathbf{C})$ be partitioned as

$$\left. \begin{aligned} \mathbf{A} &= \begin{bmatrix} \mathbf{A}_{11} & \mathbf{A}_{12} \\ \mathbf{A}_{21} & \mathbf{A}_{22} \end{bmatrix}, & \mathbf{B} &= \begin{bmatrix} \mathbf{B}_1 \\ \mathbf{B}_2 \end{bmatrix} \\ \mathbf{C} &= [\mathbf{I}_m \quad \mathbf{0}] \end{aligned} \right\} \quad (3.6)$$

There is no loss of generality in assuming that $\mathbf{C} = [\mathbf{I}_m \quad \mathbf{0}]$. This can always be achieved by change of coordinates when \mathbf{C} has full row rank.

The minimal-order observer of the 'parametric class' for the system $(\mathbf{A}, \mathbf{B}, \mathbf{C})$ defined in (3.6) has been given by O'Reilly (1983) as

$$\left. \begin{aligned} \mathbf{D} &= \mathbf{A}_{22} - \mathbf{V}_2 \mathbf{A}_{12} \\ \mathbf{G} &= \mathbf{B}_2 - \mathbf{V}_2 \mathbf{B}_1 \\ \mathbf{P} &= \mathbf{K} \begin{bmatrix} \mathbf{0} \\ \mathbf{I}_{n-m} \end{bmatrix} \\ \mathbf{E} &= \mathbf{A}_{21} - \mathbf{V}_2 \mathbf{A}_{11} + \mathbf{A}_{22} \mathbf{V}_2 - \mathbf{V}_2 \mathbf{A}_{12} \mathbf{V}_2 \\ \mathbf{V} &= \mathbf{K} \begin{bmatrix} \mathbf{I}_m \\ \mathbf{V}_2 \end{bmatrix} \\ \mathbf{K} &= [\mathbf{K}_1 \quad \mathbf{K}_2] \\ \mathbf{T} &= [-\mathbf{V}_2 \quad \mathbf{I}] \end{aligned} \right\} \quad (3.7)$$

where the matrices \mathbf{D} , \mathbf{G} , \mathbf{P} , \mathbf{E} and \mathbf{V} are the Luenberger observer parameters in (2.5). \mathbf{V}_2 is the observer gain.

Based on the matrices in (3.7) the recovery matrix for the minimal-order observer then becomes

$$\mathbf{M}_1(s) = \mathbf{K}_2(s\mathbf{I} - \mathbf{A}_{22} + \mathbf{V}_2\mathbf{A}_{12})^{-1}(\mathbf{B}_2 - \mathbf{V}_2\mathbf{B}_1) \quad (3.8)$$

Again we introduce an auxiliary system:

$$\Sigma_M: \begin{cases} \dot{\mathbf{x}} = \mathbf{A}_{11}^T \mathbf{x} + \mathbf{A}_{12}^T \mathbf{u} + \mathbf{K}_2^T \mathbf{w} \\ \mathbf{z} = \mathbf{B}_2^T \mathbf{x} + \mathbf{B}_1^T \mathbf{u} \end{cases}$$

By $\mathcal{V}^*(\Sigma_M)$ we denote the supremal controlled invariant subspace (see Stoorvogel 1990) for this auxiliary system. Now, we have the following result.

Lemma 5

Exact recovery is achieved if and only if one of the following conditions holds:

$$\left. \begin{array}{ll} \text{(i)} & \mathbf{M}_1(s) = 0 \\ \text{(ii)} & \langle \mathbf{A}_{22} - \mathbf{V}_2\mathbf{A}_{12} \mid \text{Im}(\mathbf{B}_2 - \mathbf{V}_2\mathbf{B}_1) \rangle \subset \ker \mathbf{K}_2 \\ \text{(iii)} & \text{Im} \mathbf{K}_2^T \subset \mathcal{V}^*(\Sigma_M) \end{array} \right\} \quad (3.9)$$

The second condition follows directly by using the Luenberger matrices for the minimal-order observer in the third condition in Theorem 1. The third condition follows from (ii) by applying the solution to the exact disturbance decoupling problem for systems with direct feedthrough terms (Stoorvogel 1990).

It is possible to achieve exact recovery in the following case. Assume the system is left invertible and $\text{rank}(\mathbf{B}_1) = r$, i.e. the system includes the maximal number of zeros $= n - r$ (a rare case). Then exact recovery can be obtained for minimum phase systems (Søgaard-Andersen 1986, 1987 b) by:

$$\mathbf{V}_2 = \mathbf{B}_2 \mathbf{B}_1^{-1} \quad (3.10)$$

When exact recovery cannot be obtained, asymptotic recovery can be achieved for minimum phase systems as in the full-order case.

Asymptotic recovery is achieved if the minimal-order observer gain \mathbf{V}_2 is designed as (Søgaard-Andersen 1986, 1987 b):

$$\left. \begin{array}{l} \mathbf{V}_2 = \mathbf{V}_2(q), \quad q \in \mathbb{R}^+ \\ \frac{\mathbf{V}_2(q) - \mathbf{B}_2\beta}{q} \rightarrow \mathbf{B}_2\alpha, \quad q \rightarrow \infty \end{array} \right\} \quad (3.11)$$

where $\alpha \in \ker \mathbf{B}_2$, $\beta = \mathbf{B}_1^\dagger$ and $(\mathbf{A}, \mathbf{B}, \mathbf{C})$ is minimum phase.

Equation (3.11) is a sufficient condition. The sufficient condition on \mathbf{V}_2 can be relaxed and is given by Saberi and Sannuti (1988). Observer gains satisfying (3.11) can again be designed by using LQG (Dowdle 1979, Madiwale and Williams 1985, Søgaard-Andersen 1986, 1987 b) or eigenstructure assignment (Søgaard-Andersen 1986).

As in the full-order case, the recovery matrix will converge towards a non-zero matrix function $\mathbf{M}_{I,RHP}$ in the non-minimum phase case. Explicit expressions for $\mathbf{M}_{I,RHP}$ can be found in the work of Niemann and Jannerup (1990).

Madiwale and Williams (1985) have found sufficient condition for achieving exact recovery:

$$\mathbf{V}_2(\mathbf{I} + \mathbf{A}_{12}\Phi_{22}(s)\mathbf{V}_2)^{-1}\mathbf{A}_{12}\Phi_{22}(s)(\mathbf{B}_2 - \mathbf{V}_2\mathbf{B}_1) = \mathbf{B}_1 - \mathbf{V}_2\mathbf{B}_1 \quad (3.12)$$

where

$$\Phi_{22}(s) = (s\mathbf{I} - \mathbf{A}_{22})^{-1}$$

and shown that (3.12) is satisfied if:

$$\mathbf{K}_2(s\mathbf{I} - \mathbf{A}_{22} + \mathbf{V}_2\mathbf{A}_{12})^{-1}(\mathbf{B}_2 - \mathbf{V}_2\mathbf{B}_1) = 0 \quad (3.13)$$

which is the same as $\mathbf{M}_1 = 0$.

3.3. Full-order PI observer

A proportional integral observer (PI observer) will now be used in the recovery design. The PI observer for the system $(\mathbf{A}, \mathbf{B}, \mathbf{C})$ has been given by Beale and Shafai (1989) and Shafai and Carroll (1985):

$$\left. \begin{aligned} \dot{\hat{\mathbf{x}}} &= \mathbf{A}\hat{\mathbf{x}} + \mathbf{F}(\mathbf{y} - \mathbf{C}\hat{\mathbf{x}}) + \mathbf{B}\mathbf{u} + \mathbf{H}\mathbf{w} \\ \dot{\mathbf{w}} &= \mathbf{y} - \mathbf{C}\hat{\mathbf{x}} \end{aligned} \right\} \quad (3.14)$$

where $\mathbf{w} \in \mathbb{R}^m$, \mathbf{F} is the P observer gain and \mathbf{H} the I observer gain. It is required that the observer given by (3.14) be stable, which is satisfied if

$$\lim_{t \rightarrow \infty} \mathbf{e}(t), \quad \mathbf{r} = 0$$

and

$$\lim_{t \rightarrow \infty} \mathbf{w}(t) = 0 \quad (3.15)$$

where $\mathbf{e}(t) = \hat{\mathbf{x}}(t) - \mathbf{x}(t)$ represents the observer error. Equation (3.15) is equivalent to the requirement that all the eigenvalues of the matrix

$$\mathbf{R} = \begin{bmatrix} \mathbf{A} - \mathbf{FC} & \mathbf{H} \\ -\mathbf{C} & \mathbf{0} \end{bmatrix} \quad (3.16)$$

have negative real parts (see Beale and Shafai 1989).

Note that the two gains \mathbf{F} and \mathbf{H} cannot be designed independently, which complicates the observer design. The PI observer is shown in Fig. 3.

Now the recovery matrix for the PI observer can be developed by using the equation for \mathbf{M}_1 from the Luenberger observer, because the PI observer is included in the Luenberger observer. The Luenberger matrices related to the PI observer are given by

$$\left. \begin{aligned} \mathbf{D} &= \begin{bmatrix} \mathbf{A} - \mathbf{FC} & \mathbf{H} \\ -\mathbf{C} & \mathbf{0} \end{bmatrix} \\ \mathbf{G} &= \begin{bmatrix} \mathbf{B} \\ \mathbf{0} \end{bmatrix} \\ \mathbf{P} &= [\mathbf{K} \quad \mathbf{0}] \\ \mathbf{E} &= \begin{bmatrix} \mathbf{F} \\ \mathbf{I}_m \end{bmatrix} \\ \mathbf{V} &= \mathbf{0} \\ \mathbf{T} &= \begin{bmatrix} \mathbf{I}_n \\ \mathbf{0} \end{bmatrix} \end{aligned} \right\} \quad (3.17)$$

The following result is proved in Appendix C.

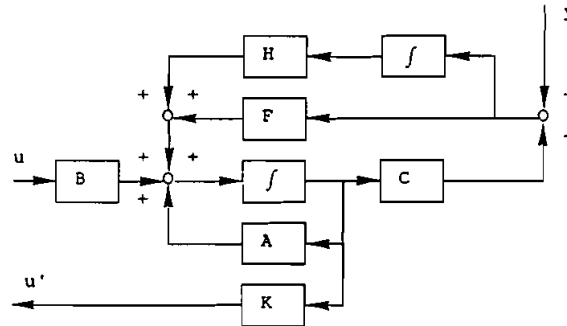

Figure 3. PI-observer.

Lemma 6

The recovery matrix is given by

$$\begin{aligned} \mathbf{M}_I(s) &= \mathbf{P}(s\mathbf{I} - \mathbf{D})^{-1}\mathbf{G} \\ &= s\mathbf{K}[s^2\mathbf{I} - s(\mathbf{A} - \mathbf{FC}) + \mathbf{HC}]^{-1}\mathbf{B} \end{aligned} \quad (3.18)$$

\mathbf{M}_I could also be interpreted as the transfer function between \mathbf{u} and \mathbf{u}' .

Lemma 7

Exact recovery is achieved if and only if one of the following conditions holds

- (i) $\mathbf{M}_I(s) = 0$
- (ii) $\left\langle \begin{bmatrix} \mathbf{A} - \mathbf{FC} & \mathbf{H} \\ -\mathbf{C} & \mathbf{0} \end{bmatrix} \middle| \text{Im} \begin{bmatrix} \mathbf{B} \\ \mathbf{0} \end{bmatrix} \right\rangle \subset \ker [\mathbf{K} \ \mathbf{0}]$

The result is again an immediate consequence of Theorem 1. Note that the recovery matrix given in Lemma 6 might equal zero in the steady state ($s \rightarrow 0$). We denote this as *time recovery*. The conditions for time recovery are given in the following lemma.

Lemma 8

Time recovery is obtained if and only if the I observer gain \mathbf{H} satisfies

$$\text{Im } \mathbf{B} \subset \text{Im } \mathbf{H} + \mathbf{A}(\ker \mathbf{C} \cap \ker \mathbf{K}) \quad (3.20)$$

For the proof, see Appendix C. This steady-state property of the PI observer indicates some advantages in the LTR design in comparison to a normal full-order observer. However, the design of PI observers is not simple (Beale and Shafai 1989, Shafai and Carroll 1985), and therefore no systematic LTR design method for PI observers has been developed until now.

PI observers have also been used in connection with LTR design by Beale and Shafai (1989) and a sufficient recovery condition has also been found by Beale and Shafai (1989):

$$(s\mathbf{F} + \mathbf{H})(s\mathbf{I} - \mathbf{C}(s\mathbf{I} - \mathbf{A})^{-1}(s\mathbf{F} + \mathbf{H}))^{-1} = \mathbf{B}(\mathbf{C}(s\mathbf{I} - \mathbf{A})^{-1}\mathbf{B})^{-1} \quad (3.21)$$

This condition can be derived from the original Doyle–Stein (Doyle and Stein 1979, 1981) sufficient recovery condition for the normal full-order observer case by substituting $\mathbf{F} + s^{-1}\mathbf{H}$ for \mathbf{F} .

Note that the recovery condition given by (3.21) concerns only square systems, and it is only satisfied in the steady state if the I observer gain is selected as $\mathbf{H} = \mathbf{B}\mathbf{W}$, where $\det(\mathbf{W}) \neq 0$, which is a reduction of the freedom in the observer design compared to the necessary and sufficient condition in Lemma 8.

3.4. Minimal-order PI observers

PI observers also exist in a minimal-order form (see Shafai and Carroll 1985). The equations for minimal-order PI observers have been given by Shafai and Carroll (1985):

$$\left. \begin{aligned} \dot{\hat{\mathbf{x}}}_2 &= (\mathbf{A}_{22} - \mathbf{V}_2\mathbf{A}_{12})\hat{\mathbf{x}}_2 + (\mathbf{A}_{22}\mathbf{V}_2 - \mathbf{V}_2\mathbf{A}_{12}\mathbf{V}_2 - \mathbf{V}_2\mathbf{A}_{11} + \mathbf{A}_{21} + \mathbf{H}_2)\mathbf{y} \\ &\quad + (\mathbf{B}_2 - \mathbf{V}_2\mathbf{B}_1)\mathbf{u} + \mathbf{H}_2\mathbf{w} \\ \dot{\mathbf{w}} &= -(\mathbf{A}_{11} + \mathbf{A}_{12}\mathbf{V}_2)\mathbf{y} - \mathbf{B}_1\mathbf{u} - \mathbf{A}_{12}\hat{\mathbf{x}}_2 \end{aligned} \right\} \quad (3.23)$$

where \mathbf{V}_2 is the P observer gain, \mathbf{H}_2 is the I observer gain and the partition of the system $(\mathbf{A}, \mathbf{B}, \mathbf{C})$ is given by (3.6).

The observer given by (3.22) is stable if all the eigenvalues of the matrix

$$\mathbf{R} = \begin{bmatrix} \mathbf{A}_{22} - \mathbf{V}_2\mathbf{A}_{12} & \mathbf{H}_2 \\ -\mathbf{A}_{12} & \mathbf{0} \end{bmatrix} \quad (3.23)$$

have negative real parts (Shafai and Carroll 1985).

As in the full-order case, the two gains \mathbf{V}_2 and \mathbf{H}_2 cannot be designed independently, which complicates the observer design.

The minimal-order PI observer is also a Luenberger observer with the following Luenberger matrices:

$$\left. \begin{aligned} \mathbf{D} &= \begin{bmatrix} \mathbf{A}_{22} - \mathbf{V}_2\mathbf{A}_{12} & \mathbf{H}_2 \\ -\mathbf{A}_{12} & \mathbf{0} \end{bmatrix} \\ \mathbf{G} &= \begin{bmatrix} \mathbf{B}_2 - \mathbf{V}_2\mathbf{B}_1 \\ -\mathbf{B}_1 \end{bmatrix} \\ \mathbf{P} &= [\mathbf{K} \quad \mathbf{0}] \begin{bmatrix} \mathbf{0} & \mathbf{0} \\ \mathbf{I}_{n-m} & \mathbf{0} \\ \mathbf{0} & \mathbf{0} \end{bmatrix} \\ \mathbf{E} &= \begin{bmatrix} \mathbf{A}_{21} - \mathbf{V}_2\mathbf{A}_{11} + \mathbf{A}_{22}\mathbf{V}_2 - \mathbf{V}_2\mathbf{A}_{12}\mathbf{V}_2 + \mathbf{H}_2 \\ -\mathbf{A}_{11} - \mathbf{A}_{12}\mathbf{V}_2 \end{bmatrix} \\ \mathbf{V} &= [\mathbf{K} \quad \mathbf{0}] \begin{bmatrix} \mathbf{I}_m \\ \mathbf{V}_2 \\ \mathbf{0} \end{bmatrix} \\ \mathbf{K} &= [\mathbf{K}_1 \quad \mathbf{K}_2] \\ \mathbf{T} &= \begin{bmatrix} -\mathbf{V}_2 & \mathbf{I} \\ -\mathbf{I} & \mathbf{0} \end{bmatrix} \end{aligned} \right\} \quad (3.24)$$

The recovery matrix can now be computed for the observer by using the matrices defined by (3.24) in (2.14).

Lemma 9

For the minimal PI observer, the recovery matrix is

$$\begin{aligned} \mathbf{M}_1(s) &= \mathbf{P}(s\mathbf{I} - \mathbf{D})^{-1}\mathbf{G} \\ &= s\mathbf{K}_2(s^2\mathbf{I} - s(\mathbf{A}_{22} - \mathbf{V}_2\mathbf{A}_{12}) + \mathbf{H}_2\mathbf{A}_{12})^{-1}(\mathbf{B}_2 - \mathbf{V}_2\mathbf{B}_1) \\ &\quad + \mathbf{K}_2(s^2\mathbf{I} - s(\mathbf{A}_{22} - \mathbf{V}_2\mathbf{A}_{12}) + \mathbf{H}_2\mathbf{A}_{12})^{-1}\mathbf{B}_1 \end{aligned} \quad (3.25)$$

The proof of Lemma 9 is omitted, because it is similar in spirit to the proof of Lemma 6.

The following result is easily obtained by exploiting (3.20).

Lemma 10

The recovery matrix given by (3.25) equals zero in the steady-state if the I observer gain \mathbf{H}_2 and the input matrices satisfy

$$\mathbf{B}_1 = \mathbf{0} \wedge \text{Im } \mathbf{B}_2 \subset \text{Im } \mathbf{H}_2 + \mathbf{A}_{22}(\ker \mathbf{A}_{12} \cap \ker \mathbf{K}_2) \quad (3.26)$$

From an LTR design point of view, the minimal-order PI observer is only interesting for systems where $\mathbf{B}_1 = \mathbf{0}$, i.e. cascade-connected systems, in which the directly excited states have to propagate through the system before reaching the output. If $\mathbf{B}_1 \neq \mathbf{0}$ the steady-state value recovery error will in general be different from zero and therefore even asymptotic recovery will not be possible.

3.5. *Q parametrized observer*

The last observer type which is treated in this section is the *Q* parametrized compensator $\mathbf{C}(\mathbf{Q})$ implemented as an observer-based compensator. The motivation for considering the *Q* structure lies in the powerful fact that it is possible to parametrize all stabilizing compensators $\mathbf{C}(\mathbf{Q})$ for $\mathbf{G}(s)$ with an arbitrary $\mathbf{Q} \in \mathcal{RH}_\infty$, as has been pointed out by Francis and Doyle (1987).

3.5.1. *Q parametrization.* The derivation of the *Q* parametrization can be performed in several ways. The normal way to find a *Q* parametrized compensator is to start with a preliminary compensator that stabilizes the plant. Doyle has shown one nice way to realize a *Q* parametrization by using an observer-based compensator as shown in Fig. 4 (for further details, see Boyd *et al.* 1988). Thus, Fig. 4 illustrates the class of *all* possible controllers which internally stabilizes the plant. It is required that the state-feedback and the observer are stable. The basic idea in the construction is that the transfer function from the terminals of the 'new' compensator \mathbf{Q} is zero. Hence, the closed-loop transfer function becomes affine in \mathbf{Q} , as shown by Boyd *et al.* (1988).

$\mathbf{Q}(s)$ in Fig. 4 is a stable proper transfer function with the realization

$$\Sigma_{\mathbf{Q}} : \begin{cases} \dot{\mathbf{x}}_q = \mathbf{A}_q \mathbf{x}_q + \mathbf{B}_q \mathbf{u}_q \\ \mathbf{y}_q = \mathbf{C}_q \mathbf{x}_q + \mathbf{D}_q \mathbf{u}_q \end{cases} \quad (3.27)$$

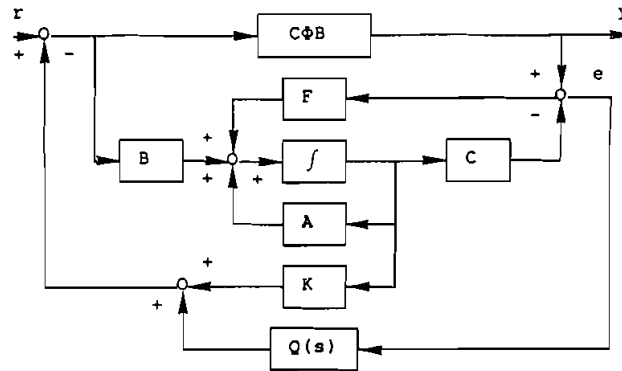

Figure 4. Class of all stabilizing compensators.

Based on the equations for the full-order observer in § 3.1 and $\mathbf{Q}(s)$ in (3.27), a state-space description of the composite system in Fig. 4 can be determined. With state vector composed \mathbf{x} , \mathbf{x}_q and $\mathbf{e} = \mathbf{x} - \hat{\mathbf{x}}$, the composite system yields

$$\begin{bmatrix} \dot{\mathbf{x}} \\ \dot{\mathbf{x}}_q \\ \dot{\mathbf{e}} \end{bmatrix} = \begin{bmatrix} \mathbf{A} - \mathbf{BK} & \mathbf{BC}_q & \mathbf{BK} + \mathbf{BD}_q\mathbf{C} \\ \mathbf{0} & \mathbf{A}_q & \mathbf{B}_q\mathbf{C} \\ \mathbf{0} & \mathbf{0} & \mathbf{A} - \mathbf{FC} \end{bmatrix} \begin{bmatrix} \mathbf{x} \\ \mathbf{x}_q \\ \mathbf{e} \end{bmatrix} \quad (\text{for } r = 0) \quad (3.28)$$

Equation (3.28) shows that poles for the state feedback, the observer and $\mathbf{Q}(s)$ can be assigned separately.

3.5.2. *LTR condition for the Q-based system.* Before the recovery matrix \mathbf{M}_1 is determined for the Q -parametrized compensator, the observer is transformed into the Luenberger form:

$$\left. \begin{aligned} \mathbf{D} &= \begin{bmatrix} \mathbf{A} - \mathbf{FC} & \mathbf{0} \\ \mathbf{B}_q\mathbf{C} & \mathbf{A}_q \end{bmatrix} \\ \mathbf{G} &= \begin{bmatrix} \mathbf{B} \\ \mathbf{0} \end{bmatrix} \\ \mathbf{P} &= [\mathbf{K} + \mathbf{D}_q\mathbf{C} \quad \mathbf{C}_q] \\ \mathbf{E} &= \begin{bmatrix} \mathbf{F} \\ \mathbf{B}_q \end{bmatrix} \\ \mathbf{V} &= -\mathbf{D}_q \\ \mathbf{T} &= \begin{bmatrix} \mathbf{I}_n \\ \mathbf{0} \end{bmatrix} \end{aligned} \right\} \quad (3.29)$$

Lemma 11

The recovery matrix for the above system is given by

$$\begin{aligned} \mathbf{M}_1(s) &= \mathbf{P}(s\mathbf{I} - \mathbf{D})^{-1}\mathbf{G} \\ &= \mathbf{K}\Phi_{\mathbf{F}}\mathbf{B} + \mathbf{Q}(s)\mathbf{C}\Phi_{\mathbf{F}}\mathbf{B} \end{aligned} \quad (3.30)$$

where $\Phi_{\mathbf{F}} = (s\mathbf{I} - \mathbf{A} + \mathbf{FC})^{-1}$.

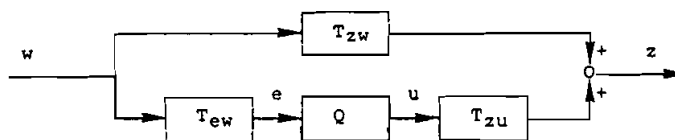

Figure 5. Model matching problem.

A proof of this result is given in Appendix D.

At first glance the minimization of \mathbf{M}_1 seems to have become more complicated by the introduction of $\mathbf{Q}(s)$. However, the minimization of \mathbf{M}_1 in Lemma 11 now has the form of a standard \mathcal{H}_∞ model-matching problem (if the infinity-norm is used instead of the 2-norm), where the constant observer gain \mathbf{F} and $\mathbf{Q}(s)$ are the design parameters.

The model matching problem is shown in Fig. 5 where the transfer matrix \mathbf{T}_{zw} represents a 'model' which is to be matched by the cascade $\mathbf{T}_{zu}\mathbf{Q}\mathbf{T}_{ew}$ of the two given transfer matrices \mathbf{T}_{zu} , \mathbf{T}_{ew} and the 'controller' \mathbf{Q} which are to be designed. It is assumed that \mathbf{T}_{zw} , \mathbf{T}_{zu} and $\mathbf{T}_{ew} \in \mathcal{RH}_\infty$ and it is required that $\mathbf{Q} \in \mathcal{RH}_\infty$. Thus the four blocks in Fig. 5 represent stable linear systems.

The model-matching criterion is to satisfy the following (Francis and Doyle 1987):

$$\sup \{ \|\mathbf{z}\|_2 \mid \mathbf{w} \in \mathcal{L}_2, \|\mathbf{w}\|_2 \leq 1 \} < \gamma \quad (3.31)$$

where $\gamma > 0$ is the prescribed matching level. Thus the energy of the error \mathbf{z} is to be within the specified bound for the worst input \mathbf{w} of unit energy. An equivalent criterion for (3.31) is (Francis and Doyle 1987):

$$\|\mathbf{T}_{zw} + \mathbf{T}_{zu}\mathbf{Q}\mathbf{T}_{ew}\|_\infty < \gamma \quad (3.32)$$

It is now simple to see, using $\mathbf{T}_{zw} = \mathbf{K}\Phi_F\mathbf{B}$, $\mathbf{T}_{zu} = \mathbf{I}$ and $\mathbf{T}_{ew} = \mathbf{C}\Phi_F\mathbf{B}$ (which are all stable), that minimizing the infinity norm of \mathbf{M}_1 is a special case of the model-matching problem in \mathcal{H}_∞ .

Since \mathbf{T}_{zw} is strictly proper, the \mathcal{H}_∞ /LTR formulated here *always* involve a standard problem in which the direct feedthrough matrices does not have full rank, i.e. a so-called singular problem. Therefore the well-known approach of Doyle *et al.* (1989) cannot be applied. Instead, the approach of Stoorvogel (1989) and Stoorvogel and Trentelman (1990) must be taken. This problem has been solved by Niemann *et al.* (1990 a). Here we briefly summarize the solution.

In order to formulate the result, we first need to introduce the following matrix function:

$$\mathbf{Z}_\gamma(\mathbf{P}) = \mathbf{A}_F\mathbf{P} + \mathbf{P}\mathbf{A}_F^T + \mathbf{B}\mathbf{B}^T + \gamma^{-2}\mathbf{P}\mathbf{K}^T\mathbf{K}\mathbf{P} \quad (3.33)$$

Where $\gamma > 0$ is a given constant specifying the desired recovery level. We assume that $(\mathbf{A}, \mathbf{B}, \mathbf{C}, \mathbf{0})$ has no transmission zeros on the imaginary axis. Under this assumption, we have the following theorem.

Theorem 3

There exists an internally stabilizing FDLTI compensator $\mathbf{Q}(s)$ which satisfies (3.32) **if and only if** there exists a $\mathbf{P} \geq 0$ satisfying

$$(1) \quad \mathbf{Z}_\gamma(\mathbf{P}) := \tilde{\mathbf{B}}\tilde{\mathbf{B}}^T \geq 0$$

- (2) $\mathbf{C}\mathbf{P} = \mathbf{0}$
 (3) $\text{rank } \tilde{\mathbf{B}} = \text{rank } \mathbf{B}$
 (4) $(\mathbf{A}_F + \gamma^{-2}\mathbf{P}\mathbf{K}^T\mathbf{K}, \tilde{\mathbf{B}}, \mathbf{C}, \mathbf{0})$

is a minimum phase system.

Moreover, a feasible choice of controller is

$$\mathbf{Q}(s) = \mathbf{K}(s\mathbf{I} - \mathbf{A}_F - \mathbf{G}\mathbf{C})^{-1}\mathbf{G} \quad (3.34)$$

where \mathbf{G} is any matrix satisfying

$$\|\mathbf{K}(s\mathbf{I} - \mathbf{A}_F - \gamma^{-2}\mathbf{P}\mathbf{K}^T\mathbf{K} - \mathbf{G}\mathbf{C})^{-1}\tilde{\mathbf{B}}\|_{\infty} < \gamma \quad (3.35)$$

The theorem has been proved by Niemann *et al.* (1990 a), who also showed that for a *minimum phase system*, (1)–(4) of Theorem 3 is satisfied for $\mathbf{P} = \mathbf{0}$, for all γ . For non-minimum phase systems, γ has to be chosen sufficiently large. The proof of the theorem is based on the work of Stoorvogel (1989), in which the conditions (1)–(4) are reduced to the solvability of an algebraic Riccati equation. Hence, the general non-minimum phase case is reduced to the solution of a reduced order Riccati equation and the almost disturbance decoupled estimation problem (3.35), which have both been thoroughly treated in the literature.

At first glance, the overall controllers emerging from the \mathcal{H}_{∞} /LTR method based on the Q observer structure appears to be of order $2n$. Fortunately, however, it turns out that the overall controller, i.e. the preliminary full-order observer paralleled with the controller (3.34), can *always* be reduced to an n th-order controller, which can be implemented as a normal full-order observer based controller. This fact is reflected in the following corollary.

Corollary 2

Let \mathbf{G} be as in Theorem 3, where γ has been chosen sufficiently large. Then the n th-order controller

$$\mathbf{C}(s) = \mathbf{K}(s\mathbf{I} - \mathbf{A}_F - \mathbf{G}\mathbf{C} + \mathbf{B}\mathbf{K})^{-1}(\mathbf{F} - \mathbf{G}) \quad (3.36)$$

when applied to the original plant $(\mathbf{A}, \mathbf{B}, \mathbf{C})$ makes the norm of the recovery matrix smaller than γ .

This easy corollary has been proved by Niemann *et al.* (1990 a).

The requirement that γ should be ‘sufficiently large’ refers to the fact that in the non-minimum phase case, arbitrarily good recovery cannot in general be achieved. However, γ might be specified as any number greater than the theoretical infimum. In the minimum phase case, γ can be chosen arbitrarily.

As a result of Corollary 2, \mathcal{H}_{∞} /LTR designed observers provide an attractive alternative to the ‘standard’ LTR design methods, since the controllers are of the same order. Furthermore, for both minimum phase and non-minimum phase systems the \mathcal{H}_{∞} based approach is more systematic in the sense that for a given level of recovery, the controllers can be directly computed by the method described by Niemann *et al.* (1990 b). This is in contrast to the usual iterative design techniques. Stoustrup and Niemann (1990) proposed a more direct \mathcal{H}_{∞} /LTR design approach in which the \mathcal{H}_{∞} optimization problem is formulated directly for

Introducing $\eta = x + Sz$ and using z and η as coordinates yields the composite system

$$\begin{bmatrix} \dot{\eta} \\ \dot{z} \end{bmatrix} = \begin{bmatrix} \mathbf{A} + \mathbf{FC} & \mathbf{0} \\ \mathbf{MC} & \mathbf{D} \end{bmatrix} \begin{bmatrix} \eta \\ z \end{bmatrix} \quad (4.5)$$

which is the dual of (2.9), and again the separation principle holds for the dual observer.

The full-loop transfer for the system in Fig. 6 at the output loop breaking point is given by

$$\mathbf{G}_0(s) = \mathbf{C}\Phi(s)\mathbf{B}\mathbf{C}(s) \quad (4.6)$$

with

$$\mathbf{C}(s) = \mathbf{N} + (\mathbf{J} + \mathbf{NCS})(s\mathbf{I} - \mathbf{D} - \mathbf{MCS})^{-1}\mathbf{M}$$

Equivalently, we define as follows the various kinds of recovery errors as the duals of those described in § 2.2.

Definition 2

By the *dual loop transfer recovery error* $\mathbf{E}_0(s)$, the *dual sensitivity recovery error* $\mathbf{E}_{S,0}(s)$ and the *dual input-output recovery error* $\mathbf{E}_{I0,0}(s)$, respectively, we denote

$$\left. \begin{aligned} \mathbf{E}_0(s) &= \mathbf{G}_{\text{TFL}}(s) - \mathbf{G}_0(s) \\ \mathbf{E}_{S,0}(s) &= \mathbf{S}_{\text{TFL}}(s) - \mathbf{S}_0(s) \\ \mathbf{E}_{I0,0}(s) &= \mathbf{G}_{\text{T,cl}}(s) - \mathbf{G}_{0,cl}(s) \end{aligned} \right\} \quad (4.7)$$

By introducing the dual of $\mathbf{M}_1(s)$ in these expressions we obtain the following lemma.

Lemma 12

Let the dual recovery matrix \mathbf{M}_0 be defined by

$$\mathbf{M}_0(s) = \mathbf{CS}(s\mathbf{I} - \mathbf{D})^{-1}\mathbf{M} \quad (4.8)$$

Then

$$\left. \begin{aligned} \mathbf{E}_0(s) &= (\mathbf{I} - \mathbf{G}_{\text{TFL}}(s))(\mathbf{I} - \mathbf{M}_0(s))^{-1}\mathbf{M}_0(s) \\ \mathbf{E}_{S,0}(s) &= \mathbf{M}_0(s)\mathbf{S}_{\text{TFL}}(s) \\ \mathbf{E}_{I0,0}(s) &= \mathbf{M}_0(s)\mathbf{S}_{\text{TFL}}(s)\mathbf{C}\Phi(s)\mathbf{B} \end{aligned} \right\} \quad (4.9)$$

The proof of Lemma 12 is equivalent to the proof of Lemmas 1, 2 and 3. Therefore it is omitted here.

The recovery matrix \mathbf{M}_0 possesses the same properties as \mathbf{M}_1 , so these can be exploited for \mathbf{M}_0 and henceforth we have the following theorem.

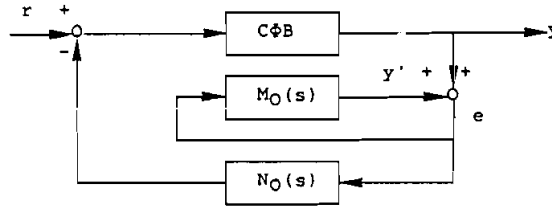

Figure 7. Dual recovery form.

Theorem 4

The exact dual recovery can be obtained if and only if one of the following equivalent conditions holds:

$$\left. \begin{array}{l}
 \text{(i)} \quad \mathbf{E}_{s,0}(s) = 0 \\
 \text{(ii)} \quad \mathbf{M}_0(s) = 0 \\
 \text{(iii)} \quad \langle \mathbf{D} \mid \text{Im } \mathbf{CS} \rangle \subset \text{ker } \mathbf{M}
 \end{array} \right\} \quad (4.10)$$

If \mathbf{D} is non-defective, (i)–(iii) are all equivalent to

$$\text{(iv)} \quad \mathbf{CS}\mathbf{v}_i = 0 \vee \mathbf{w}_i^T \mathbf{M} = 0, \quad \text{for } i = 1, \dots, p$$

where \mathbf{v}_i and \mathbf{w}_i^T are right and left eigenvectors, respectively, associated with the eigenvalues λ_i of \mathbf{D} , $p = \text{dim } \mathbf{D}$.

The proof is omitted.

Finally, the feedback system in Fig. 6 can also be transformed into the recovery form, or, more correctly, into the dual recovery form as shown in Fig. 7:

$$\mathbf{N}_0(s) = \mathbf{N} + \mathbf{J}(s\mathbf{I} - \mathbf{D})^{-1}\mathbf{M} \quad (4.11)$$

This formulation of the dual Luenberger observer shows that the coupling between \mathbf{e} and \mathbf{y}' is minimized when recovery is achieved.

5. Conclusion

In this paper we have derived necessary and sufficient conditions for the exact recovery problem as well as for the asymptotic recovery problem for general observer architectures. Three types of recovery have been considered: open loop recovery, sensitivity recovery, and input–output (or closed loop) recovery. For all observer architectures, the exact (respectively the asymptotic) recovery problem has been reduced to the problem of making the norm of the rational matrix $\mathbf{M}_1(s)$ (i.e. the recovery matrix) equal to zero (respectively ‘sufficiently’ small).

The minimization of the recovery matrix has been studied for various observer architectures proposed in the literature. For all observer types we have characterized the observer parameters for which exact recovery is achieved. For full- and minimal-order observer based controllers, these conditions have been further studied to yield necessary and sufficient conditions directly in the plant parameters for solvability of both the exact and the asymptotic recovery problem.

For PI observers, conditions for time recovery have been given, i.e. conditions for which the steady-state recovery error is zero. Conditions have been derived both for full and minimal-order PI observers.

A special structure, the Q observer, introduced by Boyd *et al.* (1988) has been considered. This general class of controller, which is based on the Youla parametrization, has been shown to be a special form of the Luenberger observer. Further, the minimization of the maximum singular value of the recovery matrix with this architecture turned out to be a model-matching problem. Hence, the linear fractional transformation appearing for Q parametrized controllers has been simplified. The model-matching problem can be solved using some recent results, both in the minimum phase and the non-minimum phase case. The resulting controllers are of order at most n . The solution to the model matching problem appearing here is thoroughly treated by Niemann *et al.* (1990 b), where results from singular \mathcal{H}_∞ theory are used.

Appendix A

Proof of Lemma 1

$$\begin{aligned} \mathbf{G}_{\text{TFL}}(s) &= \mathbf{K}\Phi(s)\mathbf{B} \\ &= (\mathbf{P}\mathbf{T} + \mathbf{V}\mathbf{C})\Phi(s)\mathbf{B} \end{aligned} \quad (\text{A } 1)$$

$$\begin{aligned} \mathbf{C}(s) &= \mathbf{V} + \mathbf{P}(s\mathbf{I} - \mathbf{D} + \mathbf{G}\mathbf{P})^{-1}(\mathbf{E} - \mathbf{G}\mathbf{V}) \\ &= \mathbf{V} + \mathbf{P}(\mathbf{I} + (s\mathbf{I} - \mathbf{D})^{-1}\mathbf{G}\mathbf{P})^{-1}(s\mathbf{I} - \mathbf{D})^{-1}(\mathbf{E} - \mathbf{G}\mathbf{V}) \\ &= \mathbf{V} + (\mathbf{I} + \mathbf{P}\Phi_{\text{D}}\mathbf{G})^{-1}\mathbf{P}\Phi_{\text{D}}(\mathbf{E} - \mathbf{G}\mathbf{V}) \\ &= (\mathbf{I} + \mathbf{P}\Phi_{\text{D}}\mathbf{G})^{-1}(\mathbf{V} + \mathbf{P}\Phi_{\text{D}}\mathbf{E}) \end{aligned} \quad (\text{A } 2)$$

$$\begin{aligned} \mathbf{G}_i(s) &= \mathbf{C}(s)\mathbf{G}(s) \\ &= (\mathbf{I} + \mathbf{P}\Phi_{\text{D}}\mathbf{G})^{-1}(\mathbf{V}\mathbf{C} + \mathbf{P}\Phi_{\text{D}}\mathbf{E}\mathbf{C})\Phi\mathbf{B} \end{aligned} \quad (\text{A } 3)$$

$$\begin{aligned} \mathbf{E}_i(s) &= (\mathbf{V}\mathbf{C} + \mathbf{P}\mathbf{T})\Phi\mathbf{B} - (\mathbf{I} + \mathbf{P}\Phi_{\text{D}}\mathbf{G})^{-1}(\mathbf{V}\mathbf{C} + \mathbf{P}\Phi_{\text{D}}\mathbf{E}\mathbf{C})\Phi\mathbf{B} \\ &= (\mathbf{I} + \mathbf{P}\Phi_{\text{D}}\mathbf{G})^{-1}(\mathbf{P}\mathbf{T} + \mathbf{P}\Phi_{\text{D}}\mathbf{G}\mathbf{V}\mathbf{C} + \mathbf{P}\Phi_{\text{D}}\mathbf{G}\mathbf{P}\mathbf{T} - \mathbf{P}\Phi_{\text{D}}\mathbf{E}\mathbf{C})\Phi\mathbf{B} \\ &= (\mathbf{I} + \mathbf{P}\Phi_{\text{D}}\mathbf{G})^{-1}\mathbf{P}\Phi_{\text{D}}((s\mathbf{I} - \mathbf{D})\mathbf{T} + \mathbf{G}\mathbf{V}\mathbf{C} + \mathbf{G}\mathbf{P}\mathbf{T} - \mathbf{E}\mathbf{C})\Phi\mathbf{B} \end{aligned} \quad (\text{A } 4)$$

Using $\mathbf{V}\mathbf{C} + \mathbf{P}\mathbf{T} = \mathbf{K}$ in (A 4) we obtain

$$\mathbf{E}_i(s) = (\mathbf{I} + \mathbf{P}\Phi_{\text{D}}\mathbf{G})^{-1}\mathbf{P}\Phi_{\text{D}}(s\mathbf{T} - \mathbf{D}\mathbf{T} + \mathbf{G}\mathbf{K} - \mathbf{E}\mathbf{C})\Phi\mathbf{B} \quad (\text{A } 5)$$

and

$$\mathbf{E}_i(s) = (\mathbf{I} + \mathbf{P}\Phi_{\text{D}}\mathbf{G})^{-1}\mathbf{P}\Phi_{\text{D}}(s\mathbf{T} - \mathbf{T}\mathbf{A} + \mathbf{T}\mathbf{B}\mathbf{K})\Phi\mathbf{B} \quad (\text{A } 6)$$

by using $\mathbf{T}\mathbf{A} - \mathbf{D}\mathbf{T} = \mathbf{E}\mathbf{C}$ in (A 5).

$$\begin{aligned} \mathbf{E}_i(s) &= (\mathbf{I} + \mathbf{P}\Phi_{\text{D}}\mathbf{G})^{-1}\mathbf{P}\Phi_{\text{D}}(\mathbf{T}(s\mathbf{I} - \mathbf{A}) + \mathbf{T}\mathbf{B}\mathbf{K})\Phi\mathbf{B} \\ &= (\mathbf{I} + \mathbf{P}\Phi_{\text{D}}\mathbf{G})^{-1}\mathbf{P}\Phi_{\text{D}}\mathbf{T}\mathbf{B}(\mathbf{I} + \mathbf{K}\Phi\mathbf{B}) \\ &= \mathbf{M}_i(s)(\mathbf{I} + \mathbf{M}_i(s))^{-1}(\mathbf{I} + \mathbf{G}_{\text{TFL}}(s)) \end{aligned} \quad (\text{A } 7)$$

Proof of Lemma 2

$$\begin{aligned}
 \mathbf{E}_1(s) &= \mathbf{K}\Phi(s)\mathbf{B} - \mathbf{C}(s)\mathbf{G}(s) \\
 &= \mathbf{I} + \mathbf{K}\Phi\mathbf{B} - (\mathbf{I} + \mathbf{C}(s)\mathbf{G}(s)) \\
 \mathbf{S}_1^{-1} &= \mathbf{I} + \mathbf{C}(s)\mathbf{G}(s) = \mathbf{I} + \mathbf{K}\Phi\mathbf{B} - \mathbf{E}_1(s) \\
 &= \mathbf{S}_{\text{TFL}}^{-1}(s) - \mathbf{M}_1(s)(\mathbf{I} + \mathbf{M}_1(s))^{-1}\mathbf{S}_{\text{TFL}}^{-1}(s) \\
 &= (\mathbf{I} + \mathbf{M}_1(s))^{-1}\mathbf{S}_{\text{TFL}}^{-1}(s)
 \end{aligned} \tag{A 8}$$

and hence

$$\mathbf{S}_1(s) = \mathbf{S}_{\text{TFL}}(s)(\mathbf{I} + \mathbf{M}_1(s)) \tag{A 9}$$

which implies

$$\mathbf{E}_{s,1}(s) = -\mathbf{S}_{\text{TFL}}(s)\mathbf{M}_1(s) \tag{A 10}$$

Appendix B

Proof of Theorem 1

The first two statements are due to Goodman (1984).

Proof of (i) \Leftrightarrow (ii). If $\mathbf{M}_1(s) = \mathbf{0}$ then Lemma 2 implies $\mathbf{E}_{s,1}(s) = \mathbf{0}$. Assume $\mathbf{E}_{s,1}(s) = \mathbf{0}$. Now, the stability of $\mathbf{A} - \mathbf{BK}$ implies that $\mathbf{I} + \mathbf{K}\Phi\mathbf{B}$ is non-singular and therefore $\mathbf{M}_1(s) = \mathbf{0}$ by Lemma 2.

Proof of (ii) \Leftrightarrow (iv). First let the recovery matrix be rewritten in the residual form as

$$\Lambda = \text{diag}(\lambda_1, \dots, \lambda_p)$$

where λ_i is the i th eigenvalue of \mathbf{D} .

$$\mathbf{V} = [\mathbf{v}_1 \ \dots \ \mathbf{v}_p], \quad \mathbf{W} = [\mathbf{w}_1 \ \dots \ \mathbf{w}_p]$$

with $\mathbf{v}_i, \mathbf{w}_i$ scaled such that

$$\mathbf{V}\mathbf{W}^H = \mathbf{W}^H\mathbf{V} = \mathbf{I} \tag{B 1}$$

It follows that

$$\mathbf{D} = \mathbf{V}\Lambda\mathbf{W}^H \tag{B 2}$$

and the recovery matrix can be rewritten as

$$\mathbf{M}_1(s) = \sum_{i=1}^p \frac{\mathbf{P}\mathbf{v}_i\mathbf{w}_i^H\mathbf{G}}{s - \lambda_i} \tag{B 3}$$

if \mathbf{D} is non-defective.

If condition (iii) holds then (B 3) implies that $\mathbf{M}_1(s) = \mathbf{0}$.

Assume $\mathbf{M}_1(s) = \mathbf{0}$. Then (B 3) implies that

$$\mathbf{0} = \mathbf{P}\mathbf{v}_i\mathbf{w}_i^H\mathbf{G} \quad \text{for all } i = 1, \dots, p \tag{B 4}$$

Let $\alpha_i \in \mathbb{R}^m$ and $\beta_i \in \mathbb{R}^r$ such that $\alpha_i = \mathbf{P}\mathbf{v}_i$ and $\beta_i^H = \mathbf{w}_i^H\mathbf{G}$. Then (B 4) implies $\alpha_i\beta_i^H = \mathbf{0}$ which implies, using (B 1), either $\alpha_i = \mathbf{0}$ or $\beta_i^H = \mathbf{0}$ (or both) for all i .

Proof of (i) \Leftrightarrow (iii). Consider a formal series expansion of $\mathbf{P}(s\mathbf{I} - \mathbf{D})^{-1}\mathbf{G}$:

$$\mathbf{P}(s\mathbf{I} - \mathbf{D})^{-1}\mathbf{G} = \mathbf{P}\mathbf{G} + s^{-1}\mathbf{P}\mathbf{D}\mathbf{G} + s^{-2}\mathbf{P}\mathbf{D}^2\mathbf{G} + \dots$$

$\mathbf{P}(s\mathbf{I} - \mathbf{D})^{-1}\mathbf{G} = \mathbf{0}$ for all s if and only if all the coefficients of its series expansion vanish. Thus,

$$\mathbf{P}(s\mathbf{I} - \mathbf{D})^{-1}\mathbf{G} \equiv \mathbf{0}$$

\Leftrightarrow

$$\mathbf{P}\mathbf{G} = \mathbf{P}\mathbf{D}\mathbf{G} = \dots = \mathbf{P}\mathbf{D}^{p-1}\mathbf{G} = \mathbf{0}$$

\Leftrightarrow

$$\mathbf{P}[\mathbf{G} \quad \mathbf{D}\mathbf{G} \quad \dots \quad \mathbf{D}^{p-1}\mathbf{G}] = \mathbf{0}$$

\Leftrightarrow

$$\text{Im} [\mathbf{G} \quad \mathbf{D}\mathbf{G} \quad \dots \quad \mathbf{D}^{p-1}\mathbf{G}] = \mathbf{0} \subset \ker \mathbf{P}$$

\Leftrightarrow

$$\langle \mathbf{D} \mid \text{Im } \mathbf{G} \rangle \subset \ker \mathbf{P}$$

Where $\langle \mathbf{D} \mid \text{Im } \mathbf{G} \rangle$ denotes the reachable subspace for the system (\mathbf{D}, \mathbf{G}) . This completes the proof of Theorem 1.

Appendix C

Proof of Lemma 6

$$\mathbf{M}_1(s) = [\mathbf{K} \quad \mathbf{0}] \begin{bmatrix} s\mathbf{I} - \mathbf{A} + \mathbf{F}\mathbf{C} & -\mathbf{H} \\ \mathbf{C} & s\mathbf{I} \end{bmatrix}^{-1} \begin{bmatrix} \mathbf{B} \\ \mathbf{0} \end{bmatrix} \quad (\text{C } 1)$$

$$= \mathbf{K}(\Phi_{\mathbf{F}} - \Phi_{\mathbf{F}}\mathbf{H}(s\mathbf{I} + \mathbf{C}\Phi_{\mathbf{F}}\mathbf{H})^{-1}\mathbf{C}\Phi_{\mathbf{F}})\mathbf{B} \quad (\text{C } 2)$$

where $\Phi_{\mathbf{F}} = (s\mathbf{I} - \mathbf{A} + \mathbf{F}\mathbf{C})^{-1}$

$$\mathbf{M}_1(s) = \mathbf{K}(\Phi_{\mathbf{F}}^{-1} + s^{-1}\mathbf{H}\mathbf{C})^{-1}\mathbf{B} \quad (\text{C } 3)$$

by using $\mathbf{A}^{-1} - \mathbf{A}^{-1}\mathbf{B}(\mathbf{C}^{-1} + \mathbf{D}\mathbf{A}^{-1}\mathbf{B})^{-1}\mathbf{D}\mathbf{A}^{-1} = (\mathbf{A} + \mathbf{B}\mathbf{C}\mathbf{D})^{-1}$

$$\mathbf{M}_1(s) = s\mathbf{K}(s\Phi_{\mathbf{F}}^{-1} + \mathbf{H}\mathbf{C})^{-1}\mathbf{B} \quad (\text{C } 4)$$

Proof of Lemma 8

By substituting $s = 0$ in (C 1) we obtain

$$\mathbf{M}_1(\mathbf{0}) = \mathbf{0}$$

\Leftrightarrow

$$[\mathbf{K} \quad \mathbf{0}] \begin{bmatrix} -\mathbf{A} + \mathbf{F}\mathbf{C} & -\mathbf{H} \\ \mathbf{C} & \mathbf{0} \end{bmatrix}^{-1} \begin{bmatrix} \mathbf{B} \\ \mathbf{0} \end{bmatrix} = \mathbf{0}$$

\Leftrightarrow

$$\text{Im} \begin{bmatrix} \mathbf{B} \\ \mathbf{0} \end{bmatrix} \subset \begin{bmatrix} -\mathbf{A} + \mathbf{F}\mathbf{C} & -\mathbf{H} \\ \mathbf{C} & \mathbf{0} \end{bmatrix} \ker [\mathbf{K} \quad \mathbf{0}]$$

\Leftrightarrow

$$\text{Im } \mathbf{B} \subset \text{Im } \mathbf{H} + (-\mathbf{A} + \mathbf{F}\mathbf{C})(\ker \mathbf{C} \cap \ker \mathbf{K})$$

\Leftrightarrow

$$\text{Im } \mathbf{B} \subset \text{Im } \mathbf{H} + \mathbf{A}(\ker \mathbf{C} \cap \ker \mathbf{K})$$

which proves the necessity and sufficiency of condition (ii) for achieving $\mathbf{E}_{S,1}(t) \rightarrow 0$ as $t \rightarrow \infty$.

Appendix D

Proof of Lemma 11

$$\begin{aligned} \mathbf{M}_1(s) &= \mathbf{P}(s\mathbf{I} - \mathbf{D})^{-1}\mathbf{G} \\ &= [\mathbf{P}_1 \quad \mathbf{P}_2] \left[s\mathbf{I} - \begin{pmatrix} \mathbf{D}_{11} & \mathbf{D}_{12} \\ \mathbf{D}_{21} & \mathbf{D}_{22} \end{pmatrix} \right]^{-1} \begin{bmatrix} \mathbf{G}_1 \\ \mathbf{0} \end{bmatrix} \end{aligned} \quad (\text{D } 1)$$

where

$$\left. \begin{aligned} \mathbf{P}_1 &= \mathbf{K} + \mathbf{D}_q \mathbf{C}, & \mathbf{P}_2 &= \mathbf{C}_q \\ \mathbf{D}_{11} &= \mathbf{A} - \mathbf{F}\mathbf{C}, & \mathbf{D}_{12} &= \mathbf{0}_q \\ \mathbf{D}_{21} &= -\mathbf{B}_q \mathbf{C}, & \mathbf{D}_{22} &= \mathbf{A}_q \\ \mathbf{G}_1 &= \mathbf{B} \end{aligned} \right\} \quad (\text{D } 2)$$

Define

$$\begin{aligned} \Phi_{11} &= (s\mathbf{I} - \mathbf{D}_{11})^{-1} \quad \text{and} \quad \Phi_{22} = (s\mathbf{I} - \mathbf{D}_{22})^{-1} \\ \mathbf{M}_1(s) &= [\mathbf{P}_1 \quad \mathbf{P}_2] \begin{bmatrix} \Phi_{11}^{-1} & \mathbf{0} \\ \mathbf{D}_{21} & \Phi_{22}^{-1} \end{bmatrix}^{-1} \begin{bmatrix} \mathbf{B} \\ \mathbf{0} \end{bmatrix} \\ &= [\mathbf{P}_1 \quad \mathbf{P}_2] \begin{bmatrix} \Phi_{11} & \mathbf{0} \\ -\Phi_{22} \mathbf{D}_{21} \Phi_{11} & \Phi_{22} \end{bmatrix} \begin{bmatrix} \mathbf{B} \\ \mathbf{0} \end{bmatrix} \\ &= \mathbf{P}_1 \Phi_{11} \mathbf{B} - \mathbf{P}_2 \Phi_{22} \mathbf{D}_{21} \Phi_{11} \mathbf{B} \quad (\text{D } 3) \\ &= \mathbf{K} \Phi_{11} \mathbf{B} + \mathbf{D}_q \mathbf{C} \Phi_{11} \mathbf{B} + \mathbf{C}_q \Phi_{22} \mathbf{B}_q \mathbf{C} \Phi_{11} \mathbf{B} \quad (\text{D } 4) \\ &= \mathbf{K} \Phi_{11} \mathbf{B} + (\mathbf{D}_q + \mathbf{C}_q \Phi_{22} \mathbf{B}_q) \mathbf{C} \Phi_{11} \mathbf{B} \quad (\text{D } 5) \\ &= \mathbf{K} \Phi_{11} \mathbf{B} + \mathbf{Q}(s) \mathbf{C} \Phi_{11} \mathbf{B} \quad (\text{D } 6) \end{aligned}$$

REFERENCES

- ATHANS, M., 1986, A tutorial on the LQG/LTR method. *Proceedings of the American Control Conference*, Seattle, Washington, pp. 1289–1296.
- BEALE, S., and SHAFAI, B., 1989, Robust control system design with a proportional integral observer. *International Journal of Control*, **50**, 97–111.
- BOYD, S. P., BALAKRISHNAN, V., BARRATT, C. H., KHRAISHI, N. M., LI, X., MEYER, D. G., and NORMAN, S. A., 1988, A new CAD method and associated architectures for linear controllers. *I.E.E.E. Transactions on Automatic Control*, **33**, 268–283.
- DOWDLE, J. R., 1979, Robust observer-based compensators. Ph.D. thesis, MIT, Cambridge, Massachusetts.
- DOYLE, J., GLOVER, K., KHARGONEKAR, P., and FRANCIS, B. A., 1989, State-space solutions to standard \mathcal{H}_2 and \mathcal{H}_∞ control problems. *I.E.E.E. Transactions on Automatic Control*, **34**, 831–847.

- DOYLE, J., and STEIN, G., 1979, Robustness with observers. *I.E.E.E. Transactions on Automatic Control*, **24**, 607–611; 1981, Multivariable feedback design: Concepts for a classical/modern synthesis. *I.E.E.E. Transactions on Automatic Control*, **26**, 4–16.
- FRANCIS, B. A., and DOYLE, J. C., 1987, Linear control theory with an \mathcal{H}_∞ optimality criterion. *SIAM Journal on Control and Optimization*, **25**, 815–844.
- GOODMAN, G. C., 1984, The LQG/LTR method and discrete-time control systems. M.Sc. thesis, Report No. LIDS-TH-1392, MIT, Cambridge, Massachusetts.
- KAILATH, T., 1980, *Linear Systems* (New York: Prentice Hall).
- LUENBERGER, D. G., 1971, An introduction to observers. *I.E.E.E. Transactions on Automatic Control*, **16**, 596–602.
- MACIEJOWSKI, J. M., 1985, Asymptotic recovery for discrete-time systems. *I.E.E.E. Transactions on Automatic Control*, **30**, 602–605.
- MADIWALE, A. N., and WILLIAMS, D. E., 1985, Some extensions of loop transfer recovery. *Proceedings of the American Control Conference*, Boston, Massachusetts, pp. 790–795.
- MATSON, C. L., and MAYBECK, P. S., 1987, On an assumed convergence result in the LQG/LTR technique. *Proceedings of the 26th I.E.E.E. Conference on Decision and Control*, Los Angeles, California, pp. 951–952.
- MOORE, J. B., and TAY, T. T., 1989, Loop recovery via $\mathcal{H}_\infty/\mathcal{H}_2$ sensitivity recovery. *International Journal of Control*, **49**, 1249–1271.
- NIEMANN, H. H., and JANNERUP, O., 1990, An analysis of pole/zero cancellation in LTR-based feedback design. *Proceedings of the American Control Conference 1990*, San Diego, California, pp. 848–853.
- NIEMANN, H. H., and SØGAARD-ANDERSEN, 1988, New results in discrete-time loop transfer recovery. *Proceedings of the American Control Conference*, Atlanta, pp. 2483–2489.
- NIEMANN, H. H., SØGAARD-ANDERSEN, and STOUSTRUP, J., 1990 a, Loop transfer recovery: analysis and design for general observer architectures. MAT-Report No. 1990-02, Feb. 16th, Mathematical Institute, Technical University of Denmark; 1990 b, \mathcal{H}_∞ optimization of the recovery matrix using the Q observer structure. MAT-Report No. 1990-27, Mathematical Institute, Technical University of Denmark.
- O'REILLY, J., 1983, *Observers for Linear Systems* (London: Academic Press).
- SABERI, A., and SANNUTI, P., 1988, Observer design for loop transfer recovery and for uncertain dynamical systems. *Proceedings of the American Control Conference*, Atlanta, Georgia, pp. 803–808, also submitted for publication in *I.E.E.E. Transactions on Automatic Control*.
- SHAFAI, B., and CARROLL, R. L., 1985, Design of proportional–integral observer for linear time-varying multivariable systems. *Proceedings of the 24th Conference on Decision and Control*, Ft. Lauderdale, Florida, pp. 597–599.
- SØGAARD-ANDERSEN, P., 1986, Issues in robust multivariable observer-based feedback design. Ph.D. thesis, Control Engineering Institute, Technical University of Denmark; 1987 a, Explicit solution to the problem of exact loop transfer recovery. *Proceedings of the American Control Conference*, Minneapolis, Minnesota, pp. 150–151; 1987 b, Loop transfer recovery with minimal-order observers. *Proceedings of the I.E.E.E. Conference on Decision and Control*, Los Angeles, California, pp. 933–938; 1989, Loop transfer

- recovery—an eigenstructure interpretation. *Control Theory and Advanced Technology*, **5**, 351–365.
- SØGAARD-ANDERSEN, P., and NIEMANN, H. H., 1989, Trade-offs in LTR-based feedback design. *Proceedings of the American Control Conference*, Pittsburgh, Pennsylvania, pp. 922–928.
- STEIN, G., and ATHANS, M., 1987, pp. 1987, The LQG/LTR procedure for multivariable feedback control design. *I.E.E.E. Transactions on Automatic Control*, **32**, 105–114.
- STOORVOGEL, A. A., 1989, The singular \mathcal{H}_∞ control problem with dynamic measurement feedback. *SIAM Journal on Control and Optimization*, to be published; 1990, The \mathcal{H}_∞ problem: a state space approach. Ph.D. dissertation, Eindhoven University of Technology.
- STOORVOGEL, A. A., and TRENTELMAN, H. H., 1990, The quadratic matrix inequality in singular \mathcal{H}_∞ control with state feedback. *SIAM Journal of Control and Optimization*, **28**, 1190–1208.
- STOUSTRUP, J., and NIEMANN, H. H., 1990, State space solutions to the \mathcal{H}_∞ /LTR design problem. Submitted for publication.
- TRENTELMAN, H. L., 1986, Almost invariant subspaces and high gain feedback. Ph.D. dissertation; Amsterdam, CWI Tract 29.
- WONHAM, W. M., 1985, *Linear Multivariable Control: a Geometric Approach*, third edition (New York: Springer-Verlag).
- ZHANG, Z., and FREUDENBERG, J. S., 1990, Loop transfer recovery for non-minimum phase plants. *I.E.E.E. Transactions on Automatic Control*, **35**, 547–553.