

## State-space solutions to the $h_{\infty}/l_{tr}$ design problem

**Niemann, Hans Henrik**

*Published in:*  
International Journal of Robust and Nonlinear Control

*Publication date:*  
1993

*Document Version*  
Publisher's PDF, also known as Version of record

[Link back to DTU Orbit](#)

*Citation (APA):*  
Niemann, H. H. (1993). State-space solutions to the  $h_{\infty}/l_{tr}$  design problem. International Journal of Robust and Nonlinear Control, 3, 1-45.

## DTU Library

Technical Information Center of Denmark

---

### General rights

Copyright and moral rights for the publications made accessible in the public portal are retained by the authors and/or other copyright owners and it is a condition of accessing publications that users recognise and abide by the legal requirements associated with these rights.

- Users may download and print one copy of any publication from the public portal for the purpose of private study or research.
- You may not further distribute the material or use it for any profit-making activity or commercial gain
- You may freely distribute the URL identifying the publication in the public portal

If you believe that this document breaches copyright please contact us providing details, and we will remove access to the work immediately and investigate your claim.

# STATE-SPACE SOLUTIONS TO THE $\mathcal{H}_\infty$ /LTR DESIGN PROBLEM

JAKOB STOUSTRUP AND HANS HENRIK NIEMANN

*Mathematical Institute, Technical University of Denmark, Building 303, DK-2800 Lyngby, Denmark*

## SUMMARY

The LTR design problem using an  $\mathcal{H}_\infty$  optimality criterion is presented for two types of recovery errors, the sensitivity recovery error and the input-output recovery error. For both errors two different approaches are presented. First, following the classical LTR design philosophy, a Luenberger observer based approach is proposed, where the  $\mathcal{H}_\infty$  part of the controller is appended to a standard full-order observer. Second, allowing for general controllers, an  $\mathcal{H}_\infty$  state-space problem is formulated directly from the recovery errors. Both approaches lead to controller orders of at most  $2n$ . In the minimum phase case, though, the order of the controllers can be reduced to  $n$  in all cases. The control problems corresponding to the various controller types are given as four different singular  $\mathcal{H}_\infty$  state-space problems, and the solutions are given in terms of the relevant equations and inequalities.

KEY WORDS Loop transfer recovery Singular  $\mathcal{H}_\infty$  theory Luenberger observer  
Youla parameterization

## 1. INTRODUCTION

In the last decade the concept of loop transfer recovery (LTR) has emerged as an important approach to the design of robust feedback controllers. The attractive theoretical properties of such controllers in combination with its conceptual and computational simplicity has motivated its popularity and spread in the control community for continuous time systems<sup>1,4,5,8,11,18,19,24,25</sup> and for discrete time systems.<sup>8,10,13</sup> The LTR philosophy establishes a systematic two-step method for the design of dynamical measurement feedback controllers. The first step is to design a static state feedback which performs according to the specifications. The second step is to design a dynamical measurement feedback controller, which 'behaves almost' like the static state feedback. In the two steps entirely different design methodologies can be applied, which make LTR an attractive alternative to 'one-shot' methods. The objective of this paper is to provide a complete  $\mathcal{H}_\infty$  design method for the second step.

Design methods as LQG/LTR, ES/LTR (i.e. eigenstructure assignment LTR) and singular perturbation LTR are all based on sufficient conditions for obtaining recovery. Further, practically only controllers based on full-order or minimal-order observers have been used for recovery design. As a result of these two drawbacks no guarantee can be given that the best controller type is selected for a given problem.

This work is supported in part by the Danish Technical Research Council, under grant no. 16-4885-1.

*This paper was recommended for publication by editor M. J. Grimble*

A first step towards a more systematic description of conditions for obtaining recovery has been done by Goodman<sup>8</sup> by the introduction of the open loop recovery error for full order observer based controllers. In Reference 14 the recovery error concept has been extended to both open and closed loop recovery errors and more general controllers have been investigated: the Luenberger observed based controller and the output feedback controller (the unknown input observer based controller). In this work, it was shown that a certain matrix-valued function, the so-called recovery matrix, plays a crucial role in the LTR problem. In the asymptotic recovery case, it turns out that both recovery error types tend to zero if and only if the recovery matrix does. Accordingly, both necessary and sufficient conditions for achieving asymptotic recovery were obtained by the study of the recovery matrix.

Methods as LQG/LTR, ES/LTR and singular perturbation LTR are mainly ad hoc, in the sense that they try to reduce a more or less unspecified part of the system. In References 21 and 23 an  $\mathcal{H}_\infty$ /LTR problem is formulated in order to reduce the norm of the recovery matrix. We shall refer to this method as an *indirect* design method. One significant problem caused by using indirect design methods is that no guarantee exists that the norm of the recovery errors decreases when the norm of the recovery matrix decreases (except in the asymptotic recovery case—see above). In fact, in the course of this paper we shall study an example, where the recovery errors even increase when the norm of the recovery matrix decreases.

Moreover, for non-minimum phase systems, most contributions so far deal only with analysis.<sup>17,19,29</sup> Hence, there is a need for systematic design procedures. A more advantageous approach to LTR controller design is therefore to use the recovery errors directly in the recovery design problem formulation, which we shall call the direct LTR design method. Till this point, only one such method has been investigated.<sup>12</sup> This recovery method imposes an  $\mathcal{H}_\infty$  constraint on the sensitivity recovery error. The method is based on coprime factorizations of the sensitivity recovery error for a system where the direct feedthrough term is assumed to have full rank. This method has two drawbacks: first, the order of the final observer based controllers is  $2n$  for square system and  $3n - 1$  otherwise in the minimum phase case. However, it is always possible to reduce the  $\mathcal{H}_\infty$  norm of the recovery errors by  $n$ th order controllers in the minimum phase case.<sup>21,23</sup> Second, for non-minimum phase systems, only the minimum phase part is considered in Reference 12 and no norm bounds are guaranteed for the overall system. But, as a matter of fact, the main importance of direct design methods, are their application to non-minimum phase systems, as will appear in the course of this paper.

The key contribution of this paper is to formulate the recovery design problem as a direct  $\mathcal{H}_\infty$  optimization problem of the recovery errors and to derive the associated  $\mathcal{H}_\infty$ /LTR controller in state-space form. The basis of this contribution is the general recovery description given in Reference 14 which is summarized in Section 2. Concurrently, two different controller structures are considered for both the sensitivity recovery problem and the input-output recovery problem. First, the so-called Q-observer is considered which is a structure, where the  $\mathcal{H}_\infty$  part of the controller is appended (in a block-diagram sense) to a standard full order observer based controller. Second, a description is given, where the  $\mathcal{H}_\infty$  standard problem emerges directly from the recovery errors.<sup>22</sup> Effectively, five different  $\mathcal{H}_\infty$  problem formulations are given at the end of Section 2.

The five  $\mathcal{H}_\infty$  problem formulated in Section 2, are all singular, i.e., they do not fulfil the usual assumptions about the rank of the direct feedthrough term. This problem is often overcome by approximation techniques, but a complete generalization of the  $\mathcal{H}_\infty$  problem to include singular  $\mathbf{D}$  matrices have been given by Stoorvogel.<sup>20</sup> The results needed in this presentation are cited in Appendix A, along with some easy corollaries. In Appendix B the relevant algorithms for the singular  $\mathcal{H}_\infty$  approach are given.

In the following two sections (Sections 3 and 4) the solutions to the four direct  $\mathcal{H}_\infty$  problems are given. State-space formulations of the  $\mathcal{H}_\infty$  problems are given; the controllers are given in state-space form and are expressed in terms of certain quadratic matrix inequalities which are generalizations of the matrix Riccati equations known from Reference 3 (and solved by similar techniques).

The results from Sections 3 and 4 are briefly summarized in Section 5. In Section 6 an exhaustive discussion of a non-minimum phase example is given. Finally, some concluding remarks are given in Section 7.

## 2. THE LTR PROBLEM FORMULATION

In this section we shall shortly describe the significance of LTR and give a brief introduction of the Luenberger observer. Further, Q-parameterized controllers will be introduced, both as Luenberger observer based controllers and as general controllers.

### 2.1. The principle of recovery design

Loop transfer recovery (LTR) is a tool applied in robust multivariable control. LTR design is the last step in a two-step design procedure for constructing dynamic compensators. The first step in the procedure is a specification of the desired properties for the final feedback control system and the design of a target loop, using a state feedback for which the specifications are satisfied. Then the LTR step follows, where the target loop is 'recovered' by an admissible measurement based controller.

Suppose the design specifications are given as bounds on the sensitivity transfer function  $S(\cdot)$  and the complementary sensitivity transfer function  $T(\cdot)$ .

$$\begin{aligned} \| \mathbf{W}_1(s)S(s) \|_\infty &< \gamma \\ \| \mathbf{W}_2(s)T(s) \|_\infty &< \gamma \end{aligned} \quad (1)$$

where  $\| \cdot \|_\infty$  is the  $\mathcal{H}_\infty$  norm. The performance specifications (e.g. asymptotic tracking, bandwidth) are expressed by the weight function  $\mathbf{W}_1(\cdot)$  on the sensitivity function.<sup>5</sup> The weight  $\mathbf{W}_2(\cdot)$  on  $T(\cdot)$  reflects system uncertainties such as disturbances, noise and modelling errors. In the sequel, the specifications will always be reflected to the input node. Independent of the selected dynamic controller type, see Sections 2.2–2.6, the systematic LTR design procedure can be applied to the design problem. First a state feedback design, the target design, which satisfies (1), is designed,<sup>1,19</sup> resulting in the target loop transfer function. Second, the LTR step is performed, where the target design is recovered systematically for each frequency by using a dynamic controller  $C(s)$ . Often the system is assumed to be minimum phase, which has been shown to be a sufficient condition<sup>14</sup> for achieving asymptotic recovery, i.e. recovering each frequency arbitrarily well. The minimum phase condition is not necessary for asymptotic recovery. Necessary and sufficient conditions are known but rather complicated. The LTR design originated as an approach to design of full order observer based controllers,<sup>4,5</sup> but it is possible to design other controller types by the LTR principle.<sup>14</sup> At this point we would like to stress, that the target design can be performed completely independent of the specific LTR procedure chosen. For non-minimum phase systems, though, it might in some cases be beneficial to design a state feedback which facilitates asymptotic recovery.<sup>17</sup>

## 2.2. Recovery errors

Let us consider a finite-dimensional, linear, time-invariant (FDLTI) plant model, represented by a state-space realization  $(\mathbf{A}, \mathbf{B}, \mathbf{C}, \mathbf{0})$ :

$$\Sigma: \begin{cases} \dot{\mathbf{x}} = \mathbf{A}\mathbf{x} + \mathbf{B}\mathbf{u} \\ \mathbf{z} = \mathbf{C}\mathbf{x} \end{cases} \quad (2)$$

with transfer function:

$$\mathbf{G}(s) = \mathbf{C}(s\mathbf{I} - \mathbf{A})^{-1}\mathbf{B} \quad (3)$$

where  $\mathbf{x} \in \mathbb{R}^n$ ,  $\mathbf{u} \in \mathbb{R}^m$ ,  $\mathbf{z} \in \mathbb{R}^r$ , with  $m > r$  and  $\mathbf{A}$ ,  $\mathbf{B}$  and  $\mathbf{C}$  are matrices of appropriate dimensions. The system is assumed to be stabilizable, detectable and left invertible. Moreover, we shall make the technical assumption, that  $\Lambda(\mathbf{A}) \cap \mathbb{C}_0 = \emptyset$ . Note, however, that this can always be achieved by applying a preliminary static output feedback. Furthermore, this preliminary static output feedback can be chosen arbitrarily small.

The associated sensitivity and input–output transfer functions for the target design and the full loop design are given by:

$$\mathbf{S}_{\text{TFL}}(s) = (\mathbf{I} - \mathbf{F}(s\mathbf{I} - \mathbf{A})^{-1}\mathbf{B})^{-1} \quad (4)$$

$$\mathbf{S}_I(s) = (\mathbf{I} - \mathbf{C}(s)\mathbf{G}(s))^{-1} \quad (5)$$

$$\mathbf{G}_{\text{TFL}}(s) = \mathbf{C}(s\mathbf{I} - \mathbf{A})^{-1}\mathbf{B}\mathbf{S}_{\text{TFL}}(s) \quad (6)$$

$$\mathbf{G}_{\text{IO}}(s) = \mathbf{C}(s\mathbf{I} - \mathbf{A})^{-1}\mathbf{B}\mathbf{S}_I(s) \quad (7)$$

where  $\mathbf{F}$  is the target static state feedback, and  $\mathbf{C}(s)$  is the controller to be designed. Using these transfer functions, two possible types of recovery errors can be defined.

### Definition 2.1

The sensitivity recovery error  $\mathbf{E}_S$  and the input–output recovery error  $\mathbf{E}_{\text{IO}}$  are defined by

$$\mathbf{E}_S(s) = \mathbf{S}_{\text{TFL}}(s) - \mathbf{S}_I(s) \quad (8)$$

$$\mathbf{E}_{\text{IO}}(s) = \mathbf{G}_{\text{TFL}}(s) - \mathbf{G}_{\text{IO}}(s) \quad (9)$$

The objective in the rest of this paper is to describe how the norm of these two recovery errors can be made small when applying different kinds of controllers, using  $\mathcal{H}_\infty$  methods. The various controller types will be introduced in the following.

## 2.3. The Luenberger observer based controller

Suppose that we wish to control the plant by a control law of the form:

$$\mathbf{u} = \mathbf{F}\hat{\mathbf{x}} + \mathbf{r} = \mathbf{w} + \mathbf{r} \quad (10)$$

where  $\hat{\mathbf{x}}$  is an estimate of the plant state. In the Luenberger observer  $\mathbf{w} = \mathbf{F}\hat{\mathbf{x}}$  is given by the following equations:

$$\Sigma_L: \begin{cases} \dot{\mathbf{z}} = \mathbf{D}\mathbf{z} + \mathbf{G}\mathbf{u} + \mathbf{E}\mathbf{y} \\ \mathbf{w} = \mathbf{P}\mathbf{z} + \mathbf{V}\mathbf{y} \end{cases} \quad (11)$$

The Luenberger matrices **T**, **D**, **E**, **G**, **P**, **V** have to satisfy:<sup>9</sup>

- (i)  $\Lambda(\mathbf{D}) \subset \mathbb{C}^-$
- (ii)  $\mathbf{TA} - \mathbf{DT} = \mathbf{EC}$
- (iii)  $\mathbf{G} = \mathbf{TB}$
- (iv)  $\mathbf{F} = \mathbf{PT} + \mathbf{VC}$

The controller obtained when applying this observer has the following transfer function:

$$\mathbf{C}(s) = \mathbf{V} + \mathbf{P}(s\mathbf{I} - \mathbf{D} - \mathbf{GP})^{-1}(\mathbf{E} + \mathbf{GV}), \mathbf{C}(s): p \times m \quad (13)$$

When the Luenberger observer based controller is applied, the two recovery errors of Definition 2.1 can be written in a more convenient form.

*Lemma 2.2*

Define

$$\mathbf{M}_I(s) = \mathbf{P}(s\mathbf{I} - \mathbf{D})^{-1}\mathbf{G} \quad (14)$$

Then

$$\mathbf{E}_S(s) = \mathbf{S}_{TFL}(s)\mathbf{M}_I(s) \quad (15)$$

$$\mathbf{E}_{IO}(s) = \mathbf{G}_{TFL}(s)\mathbf{M}_I(s) \quad (16)$$

*Proof.* The proof of Lemma 2.2 can be found in Reference 14.

The matrix-valued function  $\mathbf{M}_I(\cdot)$  turns out to be of great significance in the sequel. It describes the mismatch between the actual and the desired transfer function. Therefore we will refer to  $\mathbf{M}_I(\cdot)$  as the *recovery matrix* (for the plant input node). The recovery matrix is not just an abstract quantity, but it has a nice interpretation, namely as the transfer function from **u** to **w** in Figure 1.

One of the pay-offs of considering  $\mathbf{M}_I(s)$  for Luenberger observer based controllers is illustrated by the following lemma.

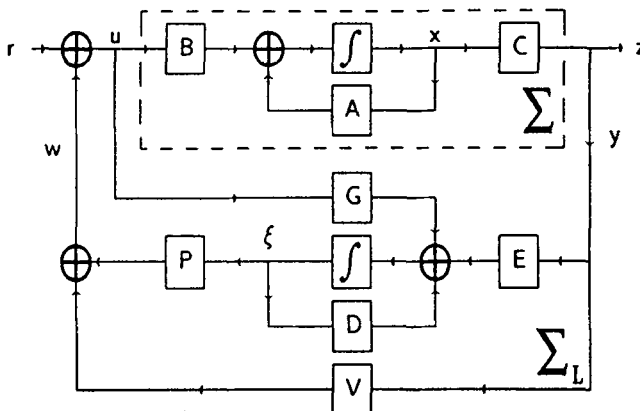

Figure 1. The Luenberger observer

*Lemma 2.3*

With  $\mathbf{M}_I$  as above, then,

$$\frac{|\sigma_i(\mathbf{S}_I) - \sigma_i(\mathbf{S}_{TFL})|}{\sigma_{\max}(\mathbf{S}_{TFL})} \leq \|\mathbf{M}_I(\cdot)\|_{\infty} \quad (17)$$

and

$$\frac{|\sigma_i(\mathbf{G}_{IO}) - \sigma_i(\mathbf{G}_{TFL})|}{\sigma_{\max}(\mathbf{G}_{TFL})} \leq \|\mathbf{M}_I(\cdot)\|_{\infty} \quad (18)$$

where  $\sigma_i(\cdot)$  is the  $i$ th singular value.

*Proof.* See Reference 26.

The two norm inequalities in Lemma 2.3 provide two measures of the relative mismatch between the full loop and the target loop, where  $\|\mathbf{M}_I(\cdot)\|_{\infty}$  is a common bound for these two measures (for all  $i$ ).  $\|\mathbf{M}_I(\cdot)\|_{\infty}$  is therefore in a certain sense a measure for the quality of the recovery design. In 26 the strong dependency of the recovery design on  $\|\mathbf{M}_I(\cdot)\|_{\infty}$  has been used in analysing the trade-off between good recovery (i.e. small  $\|\mathbf{M}_I(\cdot)\|_{\infty}$ ) and relatively low controller gains, which is inevitable for 'generic' systems. Moreover, the two inequalities also suggest that the task of reducing the norm of  $\mathbf{S}_I$  or  $\mathbf{G}_{IO}$  amounts just to the task of reducing  $\|\mathbf{M}_I(\cdot)\|_{\infty}$ , which is true in the minimum phase case (see 21 and 23). In Section 6, however, we shall give an example to illustrate, that  $\mathbf{E}_I$  or  $\mathbf{E}_{IO}$  is not always 'minimized' when  $\mathbf{M}_I$  is 'minimized'.

In the following we shall use two special cases of the Luenberger observer, the full-order observer and the Q-observer.

*2.4. The full-order observer*

The full-order observer is the most commonly used observer type. The full-order observer appears from the Luenberger expressions by the following selection of matrices:<sup>9,15</sup>

$$\begin{aligned} \mathbf{D} &= \mathbf{A} + \mathbf{K}\mathbf{C} \\ \mathbf{G} &= \mathbf{B} \\ \mathbf{P} &= \mathbf{F} \\ \mathbf{E} &= -\mathbf{K} \\ \mathbf{V} &= \mathbf{0} \\ \mathbf{T} &= \mathbf{I} \end{aligned} \quad (19)$$

where  $\mathbf{K}$  is the observer gain. The recovery matrix becomes:

$$\mathbf{M}_I(s) = \mathbf{F}(s\mathbf{I} - \mathbf{A} - \mathbf{K}\mathbf{C})^{-1}\mathbf{B} \quad (20)$$

for these Luenberger parameters.

*2.5. The Q-observer*

The second Luenberger observer based controller type to be considered in this section is the Q-parameterized controller implemented according to the construction in Reference 2. In the sequel we shall consider the reduction of the norm of the recovery errors in an  $\mathcal{H}_{\infty}$  framework.

To that end, we wish to compare the performance of controllers with a certain structure to that of general controllers, i.e., controllers that are only required to be FDLTI and internally stabilizing. One approach to characterize general controllers is the Youla parameterization of all stabilizing controllers. Briefly, the principle in the well-known Youla (or Q-) parameterization is to take *any* stabilizing controller which is thereafter fixed, and then make a certain interconnection structure. Now, the class of all stabilizing controllers is parameterized by applying the class of all  $\mathcal{H}_\infty$  systems at the interconnection nodes. In Reference 2 it is shown that the simple construction shown in Figure 2 is an implementation of the Youla parameterization. In the sequel we shall use this implementation, which we shall denote the *Q-observer*.

In the following sections, we shall need the following result from Reference 14.

*Lemma 2.4*

Assume that  $\mathbf{Q} \in \mathcal{RH}_\infty$ , with a state-space representation, say,

$$\Sigma_{\mathbf{Q}}: \begin{cases} \dot{\mathbf{x}}_{\mathbf{Q}} = \mathbf{A}_{\mathbf{Q}}\mathbf{x}_{\mathbf{Q}} + \mathbf{B}_{\mathbf{Q}}\mathbf{u}_{\mathbf{Q}} \\ \mathbf{z}_{\mathbf{Q}} = \mathbf{C}_{\mathbf{Q}}\mathbf{x}_{\mathbf{Q}} + \mathbf{D}_{\mathbf{Q}}\mathbf{u}_{\mathbf{Q}} \end{cases} \quad (21)$$

Here  $\mathbf{x}_{\mathbf{Q}} \in \mathbb{R}^q$ , where  $q$  is the order of  $\mathbf{Q}$ .

Then the corresponding Q-observer is a Luenberger observer with the following parameters:

$$\begin{aligned} \mathbf{D} &= \begin{bmatrix} \mathbf{A} + \mathbf{K}\mathbf{C} & \mathbf{0} \\ \mathbf{B}_{\mathbf{Q}}\mathbf{C} & \mathbf{A}_{\mathbf{Q}} \end{bmatrix} \\ \mathbf{G} &= \begin{bmatrix} \mathbf{B} \\ \mathbf{0} \end{bmatrix} \\ \mathbf{P} &= [\mathbf{F} + \mathbf{D}_{\mathbf{Q}}\mathbf{C} \quad \mathbf{C}_{\mathbf{Q}}] \\ \mathbf{E} &= \begin{bmatrix} -\mathbf{K} \\ -\mathbf{B}_{\mathbf{Q}} \end{bmatrix} \\ \mathbf{V} &= -\mathbf{D}_{\mathbf{Q}} \\ \mathbf{T} &= \begin{bmatrix} \mathbf{I} \\ \mathbf{0} \end{bmatrix} \end{aligned} \quad (22)$$

The corresponding recovery matrix becomes:

$$\mathbf{M}_{\mathbf{T}}(s) = \mathbf{F}(s\mathbf{I} - \mathbf{A} - \mathbf{K}\mathbf{C})^{-1}\mathbf{B} + \mathbf{Q}(s)\mathbf{C}(s\mathbf{I} - \mathbf{A} - \mathbf{K}\mathbf{C})^{-1}\mathbf{B} \quad (23)$$

*2.6. The  $\mathcal{H}_\infty$  standard setup*

The traditional LTR design approach using observer based controllers, especially the Q-observer structure, has been treated in the above section. Alternatively, we can directly formulate the  $\mathcal{H}_\infty$ /LTR design problem as an  $\mathcal{H}_\infty$  standard problem. The  $\mathcal{H}_\infty$  standard philosophy is to define a fictitious plant  $\Sigma_{\mathbf{T}}$  which is a realization of the compound transfer function on which the  $\mathcal{H}_\infty$  constraint is posed, rather than of the plant itself (see, for example, Reference 6).

Consider the closed loop system in Figure 3. Denote the transfer function of the controller  $\Sigma_{\mathcal{H}_\infty}$  by  $\mathbf{Q}(s) \in \mathcal{RH}_\infty$ . Then the closed loop transfer function from  $\mathbf{w}$  to  $\mathbf{z}$  becomes:

$$\mathbf{G}_{\mathbf{zw}}(s) = \mathbf{T}_{\mathbf{zw}}(s) + \mathbf{T}_{\mathbf{zu}}(s)\mathbf{Q}(s)(\mathbf{I} - \mathbf{T}_{\mathbf{yu}}(s)\mathbf{Q}(s))^{-1}\mathbf{T}_{\mathbf{yw}}(s) \quad (24)$$



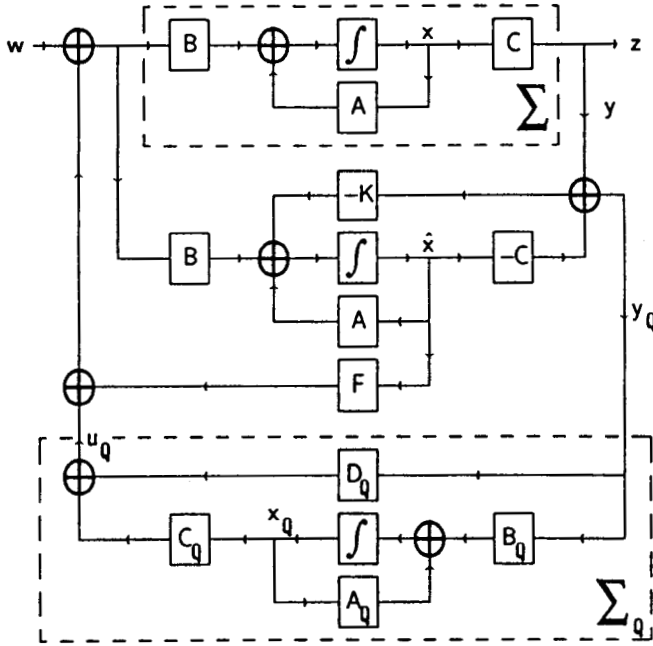
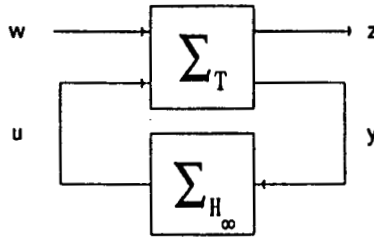

Figure 2. The Q-observer

Figure 3. The  $\mathcal{H}_\infty$  standard problem

where  $T_{zw}(s)$ ,  $T_{zu}(s)$ ,  $T_{yu}(s)$  and  $T_{yw}(s)$  are the open loop transfer function from  $w \mapsto z$ ,  $u \mapsto z$ ,  $u \mapsto y$  and  $w \mapsto y$  respectively.

Now, with  $G_{zw}(s)$  being the sensitivity recovery error  $E_S(s)$  introduced in Definition 2.1, we have:

*Lemma 2.5*

A linear fractional transformation of  $E_S(s)$  in the form (24) is given by the following transfer functions:

$$\begin{aligned}
 T_{zw}(s) &= (\mathbf{I} - \mathbf{F}(s\mathbf{I} - \mathbf{A})^{-1}\mathbf{B})^{-1} - \mathbf{I} \\
 T_{zu}(s) &= -\mathbf{I} \\
 T_{yu}(s) &= \mathbf{C}(s\mathbf{I} - \mathbf{A})^{-1}\mathbf{B} \\
 T_{yw}(s) &= \mathbf{C}(s\mathbf{I} - \mathbf{A})^{-1}\mathbf{B}
 \end{aligned} \tag{25}$$

*Proof.* The proof is omitted. It follows directly from the definition of  $\mathbf{E}_S(s)$ .

Similarly, for  $\mathbf{E}_{IO}(s)$  we have:

*Lemma 2.6*

A linear fractional transformation of  $\mathbf{E}_{IO}(s)$  in the form (24) is given by the following transfer functions:

$$\begin{aligned} \mathbf{T}_{zw}(s) &= \mathbf{C}(s\mathbf{I} - \mathbf{A} - \mathbf{BF})^{-1}\mathbf{B} - \mathbf{C}(s\mathbf{I} - \mathbf{A})^{-1}\mathbf{B} \\ \mathbf{T}_{zu}(s) &= -\mathbf{C}(s\mathbf{I} - \mathbf{A})^{-1}\mathbf{B} \\ \mathbf{T}_{yu}(s) &= \mathbf{C}(s\mathbf{I} - \mathbf{A})^{-1}\mathbf{B} \\ \mathbf{T}_{yw}(s) &= \mathbf{C}(s\mathbf{I} - \mathbf{A})^{-1}\mathbf{B} \end{aligned} \quad (26)$$

*Proof.* The proof is straightforward.

State-space representations for these two models of  $\mathbf{E}_S(s)$  and  $\mathbf{E}_{IO}(s)$  are given in Sections 3 and 4.

*2.7.  $\mathcal{H}_\infty$  formulation of the loop transfer recovery problem*

The  $\mathcal{H}_\infty$  version of the LTR design problem can be stated in a number of ways which will turn out to have slightly different answers.

In References 21 and 23 the following problem was treated:

*Problem 1*

Let  $\gamma > 0$  be given. Find, if possible, a FDLTI system  $\mathbf{Q}(s)$  such that:

$$\|\mathbf{M}_I(\cdot)\|_\infty < \gamma \quad (27)$$

or, equivalently,

$$\|\mathbf{F}(s\mathbf{I} - \mathbf{A} - \mathbf{KC})^{-1}\mathbf{B} + \mathbf{Q}(s)\mathbf{C}(s\mathbf{I} - \mathbf{A} - \mathbf{KC})^{-1}\mathbf{B}\|_\infty < \gamma \quad (28)$$

is achieved, and the closed loop system is internally stable. Here  $\|\cdot\|_\infty$  is the  $\mathcal{H}_\infty$  norm.

Thus, using the Q-observer structure in this formulation, the solution will immediately give us a Luenberger observer based controller, with the structure of Lemma 2.4.

For the asymptotic recovery case, any series of controllers which make the norm of  $\mathbf{M}_I(s)$  tend to zero, also make the norms of the two recovery errors in Definition 2.1 tend to zero. Consequently, we can just apply the simple procedure outlined in 21 and 23 for reducing  $\mathbf{M}_I(\cdot)$ , even if the original goal was to reduce  $\mathbf{E}_S(\cdot)$  or  $\mathbf{E}_{IO}(\cdot)$ . This will be called *indirect design*. The resulting controllers turn out to be of dynamic order not greater than  $n$ .

It might be, though that in the case where asymptotic recovery is not possible, we are in a situation where the norms of  $\mathbf{E}_S(\cdot)$  and  $\mathbf{E}_{IO}(\cdot)$  are not 'minimized' by the controller which 'minimize' the norm of  $\mathbf{M}_I(\cdot)$ . An example of this is given in Section 6. Hence, it is of interest to make a problem statement which directly involves the norms of  $\mathbf{E}_S(\cdot)$  and  $\mathbf{E}_{IO}(\cdot)$ . This can be formulated either as a standard  $\mathcal{H}_\infty$  problem, or as a standard  $\mathcal{H}_\infty$  problem where we furthermore require the solution to be in the Q-observer form.

*Problem 2*

Let  $\gamma > 0$  be given. Find, if possible, a FDLTI system  $\mathbf{Q}(s)$  such that when applied in a Q-observer the closed loop is internally stable, and:

$$\|\mathbf{E}_S(\cdot)\|_\infty < \gamma \quad (29)$$

or, equivalently,

$$\|(\mathbf{I} + \mathbf{F}(s\mathbf{I} - \mathbf{A} - \mathbf{BF})^{-1}\mathbf{B})(\mathbf{F}(s\mathbf{I} - \mathbf{A} - \mathbf{KC})^{-1}\mathbf{B} + \mathbf{Q}(s)\mathbf{C}(s\mathbf{I} - \mathbf{A} - \mathbf{KC})^{-1}\mathbf{B})\|_\infty < \gamma \quad (30)$$

The Q-observer expression for  $\mathbf{E}_S(s)$  and the following for  $\mathbf{E}_{IO}(s)$  has been derived in Reference 14. With no constraints on the controller type we get the following formulation.

*Problem 3*

Let  $\gamma > 0$  be given. Find, if possible, a FDLTI controller  $\mathbf{Q}(s)$  such that when applied as a dynamic measurement feedback controller we achieve:

$$\|\mathbf{E}_S(\cdot)\|_\infty < \gamma \quad (31)$$

or, equivalently,

$$\|\mathbf{F}(s\mathbf{I} - \mathbf{A} - \mathbf{BF})^{-1}\mathbf{B} - \mathbf{Q}(s)(\mathbf{I} - \mathbf{C}(s\mathbf{I} - \mathbf{A})^{-1}\mathbf{B}\mathbf{Q}(s))^{-1}\mathbf{C}(s\mathbf{I} - \mathbf{A})^{-1}\mathbf{B}\|_\infty < \gamma \quad (32)$$

is achieved, and the closed loop system is internally stable.

Problems 2 and 3 are treated in Section 3. Correspondingly, we consider the  $\mathcal{H}_\infty$  problem formulated for  $\mathbf{E}_{IO}$ , both with a Q-observer based controller, and directly as a standard problem.

*Problem 4*

Let  $\gamma > 0$  be given. Find, if possible, a FDLTI system  $\mathbf{Q}(s)$  such that when applied in a Q-observer:

$$\|\mathbf{E}_{IO}(\cdot)\|_\infty < \gamma \quad (33)$$

or, equivalently,

$$\|\mathbf{C}(s\mathbf{I} - \mathbf{A} - \mathbf{BF})^{-1}\mathbf{B}(\mathbf{F}(s\mathbf{I} - \mathbf{A} - \mathbf{KC})^{-1}\mathbf{B} + \mathbf{Q}(s)\mathbf{C}(s\mathbf{I} - \mathbf{A} - \mathbf{KC})^{-1}\mathbf{B})\|_\infty < \gamma \quad (34)$$

is achieved, and the closed loop system is internally stable.

*Problem 5*

Let  $\gamma > 0$  be given. Find, if possible, a FDLTI controller  $\mathbf{Q}(s)$  such that when applied as a dynamic measurement feedback controller we achieve:

$$\|\mathbf{E}_{IO}(\cdot)\|_\infty < \gamma \quad (34)$$

or, equivalently,

$$\|\mathbf{C}(s\mathbf{I} - \mathbf{A} - \mathbf{BF})^{-1}\mathbf{B} - \mathbf{C}(s\mathbf{I} - \mathbf{A})^{-1}\mathbf{B} - \mathbf{C}(s\mathbf{I} - \mathbf{A})^{-1}\mathbf{B}\mathbf{Q}(s)(\mathbf{I} - \mathbf{C}(s\mathbf{I} - \mathbf{A})^{-1}\mathbf{B}\mathbf{Q}(s))^{-1}\mathbf{C}(s\mathbf{I} - \mathbf{A})^{-1}\mathbf{B}\|_\infty < \gamma \quad (36)$$

is achieved, and the closed loop system is internally stable.

Problems 4 and 5 will be treated in Section 4.

Note that from the results of Reference 2, it follows that solvability of Problem 2 (resp. 4) is equivalent to solvability of Problem 3 (resp. 5).

### 3. THE SENSITIVITY $\mathcal{H}_\infty$ /LTR DESIGN PROBLEM

In the following we shall consider the sensitivity recovery problem formulated with an  $\mathcal{H}_\infty$  optimality criterion. Two different formulations will be considered, which both impose an  $\mathcal{H}_\infty$  norm constraint on the sensitivity recovery error. Following the approach of References 14, 21 and 23, observer based controllers will be studied, which possess the Q-observer structure introduced in Section 2 which is based on the Youla (Q-) parameterization (Problem 2). In Section 3.3, a more direct approach will be taken (Problem 3), where no preliminary compensator is introduced, and the  $\mathcal{H}_\infty$  optimization problem is formulated without restrictions on the controller structure. Hence, the latter follows strictly the ‘standard problem’ philosophy of  $\mathcal{H}_\infty$  theory, whereas the former is more conceptually clear from an LTR point of view, since the corresponding controllers simply are classical, full state, observer based controllers, augmented (in a block diagram sense) by the required  $\mathcal{H}_\infty$  dynamics. As a drawback this implies that the controller order is initially larger than the ‘standard problem’ controllers. Fortunately, though, the superfluous controller states can easily be dismissed, as will be shown in the sequel. For the Q-observer based  $\mathcal{H}_\infty$  problem, the sensitivity error is affine in the controller, whereas the sensitivity error is a general linear fractional transformation for the  $\mathcal{H}_\infty$  standard problem formulation. In the course of this section it will turn out that the two controller types, solving the  $\mathcal{H}_\infty$ /LTR problem in the two formulations, will have significant similarities, and design methods will be given for each controller type.

#### 3.1. Preliminaries and notation

In the following we shall subscribe extensively to the so-called singular  $\mathcal{H}_\infty$  theory in the approach of Reference 20. An introduction to this approach as well as a summary of the most important results for our needs is given in Appendix A. The algorithms involved are described in Appendix B.

Briefly the principle in the approach of Reference 20 is the following. First, a certain *quadratic matrix inequality* is considered, which along with two algebraic constraints (rank conditions) guarantees uniqueness of a solution. Once this solution to the quadratic matrix inequality has been obtained, a new system is constructed through the *full information transformation* (see Appendix A). For this transformed system another inequality, the *dual quadratic matrix inequality* is considered, again with two associated rank conditions. Eventually, once the unique solution to the dual quadratic matrix inequality has been determined, the transformed system is itself transformed by a dual transformation, the *full control transformation*. It so happens that the doubly transformed system (1) has the same controllers as solution to the  $\mathcal{H}_\infty$  problem as the original system, and (2) is minimum phase. These two facts imply that after the two transformations the solution to the original problem is easily obtained — see Appendix A.

For further details of the applied singular  $\mathcal{H}_\infty$  approach please refer to Appendix A. Here we shall introduce some required concepts and notation. Consider the following dynamic system:

$$\Sigma: \begin{cases} \dot{\mathbf{x}} = \mathbf{A}\mathbf{x} + \mathbf{B}\mathbf{u} + \mathbf{E}\mathbf{w} & \mathbf{x} \in \mathbb{R}^n, \mathbf{u} \in \mathbb{R}^m, \mathbf{w} \in \mathbb{R}^q \\ \mathbf{y} = \mathbf{C}_1\mathbf{x} + \mathbf{D}_1\mathbf{w} & \mathbf{y} \in \mathbb{R}^p \\ \mathbf{z} = \mathbf{C}_2\mathbf{x} + \mathbf{D}_2\mathbf{u} & \mathbf{z} \in \mathbb{R}^r \end{cases} \quad (37)$$

where  $\mathbf{A}, \mathbf{B}, \mathbf{E}, \mathbf{C}_1, \mathbf{D}_1, \mathbf{C}_2$  and  $\mathbf{D}_2$  are matrices of appropriate dimensions. Based on these matrices, we define the following two matrix valued functions:

$$\mathbf{F}_\gamma(\mathbf{P}) = \begin{bmatrix} \mathbf{A}^T \mathbf{P} + \mathbf{P} \mathbf{A} + \mathbf{C}_2^T \mathbf{C}_2 + \gamma^{-2} \mathbf{P} \mathbf{E} \mathbf{E}^T \mathbf{P} & \mathbf{P} \mathbf{B} + \mathbf{C}_2^T \mathbf{D}_2 \\ \mathbf{B}^T \mathbf{P} + \mathbf{D}_2^T \mathbf{C}_2 & \mathbf{D}_2^T \mathbf{D}_2 \end{bmatrix} \quad (38)$$

$$\mathbf{G}_\gamma(\mathbf{Q}) = \begin{bmatrix} \mathbf{A} \mathbf{Q} + \mathbf{Q} \mathbf{A}^T + \mathbf{E} \mathbf{E}^T + \gamma^{-2} \mathbf{Q} \mathbf{C}_2^T \mathbf{C}_2 \mathbf{Q} & \mathbf{Q} \mathbf{C}_1^T + \mathbf{E} \mathbf{D}_1^T \\ \mathbf{C}_1 \mathbf{Q} + \mathbf{D}_1 \mathbf{E}^T & \mathbf{D}_1 \mathbf{D}_1^T \end{bmatrix} \quad (39)$$

Then we shall say that  $\mathbf{P} \geq \mathbf{0}$  is a *solution to the quadratic matrix inequality* if and only if the following three conditions are all satisfied:

$$\mathbf{F}_\gamma(\mathbf{P}) \geq \mathbf{0} \quad (40)$$

$$\text{rank } \mathbf{F}_\gamma(\mathbf{P}) = \text{normrank } \mathbf{C}_2(s\mathbf{I} - \mathbf{A})^{-1} \mathbf{B} + \mathbf{D}_2 \quad (41)$$

$$\text{rank} \begin{bmatrix} s\mathbf{I} - \mathbf{A} - \gamma^{-2} \mathbf{E} \mathbf{E}^T \mathbf{P} - \mathbf{B} \\ \mathbf{F}_\gamma(\mathbf{P}) \end{bmatrix} = n + \text{normrank } \mathbf{C}_2(s\mathbf{I} - \mathbf{A})^{-1} \mathbf{B} + \mathbf{D}_2, \quad \forall s \in \mathbb{C}^+ \cup \mathbb{C}^0 \quad (42)$$

where  $\text{normrank } \mathbf{M}(\cdot)$  is the maximal rank of  $\mathbf{M}(s)$  over all  $s \in \mathbb{C}$ . An algorithm for finding  $\mathbf{P}$  satisfying (40–42) is given in Appendix B. We also need to introduce the *dual quadratic matrix inequality*. We say that  $\mathbf{Q} \geq \mathbf{0}$  is a *solution to the dual quadratic matrix inequality* if:

$$\mathbf{G}_\gamma(\mathbf{Q}) \geq \mathbf{0} \quad (43)$$

$$\text{rank } \mathbf{G}_\gamma(\mathbf{Q}) = \text{normrank } \mathbf{C}_1(s\mathbf{I} - \mathbf{A})^{-1} \mathbf{E} + \mathbf{D}_1 \quad (44)$$

$$\text{rank} \begin{bmatrix} s\mathbf{I} - \mathbf{A} - \gamma^{-2} \mathbf{Q} \mathbf{C}_2^T \mathbf{C}_2 & \mathbf{G}_\gamma(\mathbf{Q}) \\ -\mathbf{C}_1 & \end{bmatrix} = n + \text{normrank } \mathbf{C}_1(s\mathbf{I} - \mathbf{A})^{-1} \mathbf{E} + \mathbf{D}_1, \quad \forall s \in \mathbb{C}^+ \cup \mathbb{C}^0 \quad (45)$$

### 3.2. Sensitivity recovery using the Q-observer

Using the Q-observer introduced in Section 2, the sensitivity recovery error is given by:

$$\mathbf{E}_S(s) = \mathbf{S}_{\text{TFL}}(s) \mathbf{M}_I(s) = (\mathbf{I} + \mathbf{F} \Phi_{\mathbf{F}} \mathbf{B})(\mathbf{F} \Phi_{\mathbf{K}} \mathbf{B} + \mathbf{Q}(s) \mathbf{C} \Phi_{\mathbf{K}} \mathbf{B}) \quad (46)$$

The state-space formulation of equation (46) is given by:

$$\Sigma_{S,Q}: \begin{cases} \dot{\mathbf{x}} = \begin{bmatrix} \mathbf{A} + \mathbf{K} \mathbf{C} & \mathbf{0} \\ \mathbf{B} \mathbf{F} & \mathbf{A} + \mathbf{B} \mathbf{F} \end{bmatrix} \mathbf{x} + \begin{bmatrix} \mathbf{0} \\ \mathbf{B} \end{bmatrix} \mathbf{u} + \begin{bmatrix} \mathbf{B} \\ \mathbf{0} \end{bmatrix} \mathbf{w} \\ \mathbf{y} = \begin{bmatrix} \mathbf{C} & \mathbf{0} \end{bmatrix} \mathbf{x} + \mathbf{0} \mathbf{w} \\ \mathbf{z} = \begin{bmatrix} \mathbf{F} & \mathbf{F} \end{bmatrix} \mathbf{x} + \mathbf{I} \mathbf{u} \end{cases} \quad (47)$$

or, in short

$$\Sigma_{S,Q}: \begin{cases} \dot{\mathbf{x}} = \bar{\mathbf{A}} \mathbf{x} + \bar{\mathbf{B}} \mathbf{u} + \bar{\mathbf{E}} \mathbf{w} \\ \mathbf{y} = \bar{\mathbf{C}}_1 \mathbf{x} + \bar{\mathbf{D}}_1 \mathbf{w} \\ \mathbf{z} = \bar{\mathbf{C}}_2 \mathbf{x} + \bar{\mathbf{D}}_2 \mathbf{u} \end{cases} \quad (48)$$

For this system Assumption A.1 amounts to the condition that  $(\mathbf{A}, \mathbf{B}, \mathbf{C}, \mathbf{0})$  has neither zeros nor poles on the imaginary axis (see Appendix C). This is assumed throughout this section.

Note that  $\mathbf{D}_2 = \mathbf{I}$  is injective and  $\mathbf{D}_1 = \mathbf{0}$ , which means that the quadratic matrix inequality is regular and that the dual quadratic matrix inequality is totally singular. First, we wish to

find a solution to the quadratic matrix inequality, so we can perform the full information transformation (see Appendix A). Using injectiveness of  $\mathbf{D}_2$  to apply Corollary A.3 the solution to the quadratic matrix inequality is found:

*Theorem 3.1*

For the system  $\Sigma_{S,Q}$  described by (47), the solution of the quadratic matrix inequality with the associated rank conditions, is:

$$\bar{\mathbf{P}} = \begin{bmatrix} \mathbf{0} & \mathbf{0} \\ \mathbf{0} & \mathbf{P} \end{bmatrix} \quad (49)$$

where  $\mathbf{P}$  is the unique solution to the algebraic Riccati equation:

$$\mathbf{A}^T \mathbf{P} + \mathbf{P} \mathbf{A} - \mathbf{P} \mathbf{B} \mathbf{B}^T \mathbf{P} = \mathbf{0} \quad (50)$$

$\mathbf{P}$  is given by:

$$\mathbf{P} = -\Pi^T (\Pi \mathbf{G}_c \Pi^T)^{-1} \Pi \quad (51)$$

Here,  $\mathbf{G}_c$  is the controllability gramian, and  $\Pi$  is the orthogonal projection on to  $\mathcal{X}(\mathbf{A})^\perp$  along  $\mathcal{X}(\mathbf{A})$ , the space of generalized stable eigenvectors of  $\mathbf{A}$ .

$\bar{\mathbf{F}}_\gamma(\bar{\mathbf{P}})$  factorizes as:

$$\bar{\mathbf{F}}_\gamma(\bar{\mathbf{P}}) = \begin{bmatrix} \mathbf{F}^T \\ \mathbf{P} \mathbf{B} + \mathbf{F}^T \\ \mathbf{I} \end{bmatrix} [\mathbf{F} \ \mathbf{B}^T \mathbf{P} + \mathbf{F} \ \mathbf{I}] = \begin{bmatrix} \bar{\mathbf{C}}_{2,P}^T \\ \bar{\mathbf{D}}_P^T \end{bmatrix} [\bar{\mathbf{C}}_{2,P} \ \bar{\mathbf{D}}_P] \quad (52)$$

*Proof.* See Appendix C.

Note that the solution of the quadratic matrix inequality does not depend on  $\gamma$ . Further, in the special case when  $\mathbf{A}$  is stable,  $\bar{\mathbf{P}} = \mathbf{0}$  is the unique solution, and the resulting full information transformation (see Appendix A) in this case is the identity.

In general, performing the full information transformation (see Appendix A), we get the following matrices:

$$\begin{aligned} \bar{\mathbf{A}}_P &= \bar{\mathbf{A}} \\ \bar{\mathbf{C}}_{1,P} &= \bar{\mathbf{C}}_1 \\ \bar{\mathbf{C}}_{2,P} &= [\mathbf{F} \ \mathbf{B}^T \mathbf{P} + \mathbf{F}] \\ \bar{\mathbf{D}}_P &= \bar{\mathbf{D}}_2 \end{aligned} \quad (53)$$

Now a solution  $\bar{\mathbf{Y}}$  to the dual quadratic matrix inequality for the transformed system has to be found in order to determine the corresponding full control transformation. Using the dual of Corollary A.4 one can easily see that:

*Lemma 3.2*

Let the matrices  $\bar{\mathbf{A}}_P, \bar{\mathbf{B}}, \bar{\mathbf{E}}, \bar{\mathbf{C}}_{1,P}, \bar{\mathbf{C}}_{2,P}, \bar{\mathbf{D}}_1$  and  $\bar{\mathbf{D}}_P$  be as in (47), (48) and (53). Then the solution of the associated dual quadratic matrix inequality,

$$\bar{\mathbf{Y}} = \begin{bmatrix} \mathbf{Y}_{11} & \mathbf{Y}_{12} \\ \mathbf{Y}_{12}^T & \mathbf{Y}_{22} \end{bmatrix} \quad (54)$$

satisfies:

$$\mathbf{C}\mathbf{Y}_{11} = \mathbf{0} \quad \text{and} \quad \mathbf{C}\mathbf{Y}_{12} = \mathbf{0}$$

$\bar{\mathbf{G}}_\gamma(\bar{\mathbf{Y}})$  factorizes as:

$$\bar{\mathbf{G}}_\gamma(\bar{\mathbf{Y}}) = \begin{bmatrix} \bar{\mathbf{E}}_{P,Q} \\ \mathbf{0} \end{bmatrix} \times [\bar{\mathbf{E}}_{P,Q}^T \quad \mathbf{0}] \quad (55)$$

The conditions under which the dual quadratic matrix inequality has the solution  $\bar{\mathbf{Y}} = \mathbf{0}$  are different from the conditions under which the (primary) quadratic matrix inequality has the solution  $\bar{\mathbf{P}} = \mathbf{0}$  as it is seen from the following corollary.

### Corollary 3.3

Assume that the system  $(\mathbf{A}, \mathbf{B}, \mathbf{C}, \mathbf{0})$  is invertible and minimum phase. Then  $\bar{\mathbf{Y}} = \mathbf{0}$  is a solution of the dual quadratic matrix inequality satisfying the involved rank conditions. Conversely,  $\bar{\mathbf{Y}} = \mathbf{0}$  is a solution of the dual quadratic matrix inequality only if  $(\mathbf{A}, \mathbf{B}, \mathbf{C}, \mathbf{0})$  is invertible and minimum phase. In this case no second (full control) transformation is needed.

*Proof.* See Appendix C.

For  $\bar{\mathbf{Y}} \neq \mathbf{0}$  the full control transformation proceeds as follows:

$$\bar{\mathbf{A}}_{P,Q} = \bar{\mathbf{A}}_P + \gamma^{-2} \bar{\mathbf{Y}} \bar{\mathbf{C}}_{2,P}^T \bar{\mathbf{C}}_{2,P} = \begin{bmatrix} \mathbf{A}_{P,Q}^{11} & \mathbf{A}_{P,Q}^{12} \\ \mathbf{A}_{P,Q}^{21} & \mathbf{A}_{P,Q}^{22} \end{bmatrix} \quad (56)$$

with:

$$\begin{aligned} \mathbf{A}_{P,Q}^{11} &= \mathbf{A}_K + \gamma^{-2} \mathbf{Y}_{11} \mathbf{F}^T \mathbf{F} + \gamma^{-2} \mathbf{Y}_{12} (\mathbf{P} \mathbf{B} \mathbf{F} + \mathbf{F}^T \mathbf{F}) \\ \mathbf{A}_{P,Q}^{12} &= \gamma^{-2} \mathbf{Y}_{11} (\mathbf{F}^T \mathbf{B}^T \mathbf{P} + \mathbf{F}^T \mathbf{F}) + \gamma^{-2} \mathbf{Y}_{12} (\mathbf{P} \mathbf{B} \mathbf{B}^T \mathbf{P} + \mathbf{F}^T \mathbf{F}) \\ \mathbf{A}_{P,Q}^{21} &= \mathbf{B} \mathbf{F} + \gamma^{-2} \mathbf{Y}_{12} \mathbf{F}^T \mathbf{F} + \gamma^{-2} \mathbf{Y}_{12} (\mathbf{P} \mathbf{B} \mathbf{F} + \mathbf{F}^T \mathbf{F}) \\ \mathbf{A}_{P,Q}^{22} &= \mathbf{A}_F + \gamma^{-2} \mathbf{Y}_{12} (\mathbf{F}^T \mathbf{B}^T \mathbf{P} + \mathbf{F}^T \mathbf{F}) + \gamma^{-2} \mathbf{Y}_{22} (\mathbf{P} \mathbf{B} \mathbf{B}^T \mathbf{P} + \mathbf{F}^T \mathbf{F}) \end{aligned}$$

and

$$\bar{\mathbf{B}}_{P,Q} = \bar{\mathbf{B}} + \gamma^{-2} \bar{\mathbf{Y}} \bar{\mathbf{C}}_{2,P}^T \bar{\mathbf{D}}_P = \begin{bmatrix} \gamma^{-2} \mathbf{Y}_{11} \mathbf{F}^T + \gamma^{-2} \mathbf{Y}_{12} (\mathbf{P} \mathbf{B} + \mathbf{F}^T) \\ \mathbf{B} + \gamma^{-2} \mathbf{Y}_{12} \mathbf{F}^T + \gamma^{-2} \mathbf{Y}_{22} (\mathbf{P} \mathbf{B} + \mathbf{F}^T) \end{bmatrix} \quad (57)$$

After the full information and full control transformations (see Appendix A), the controller  $\mathbf{U} = \mathbf{Q}(s)\mathbf{y}$  described in Theorem A.5 can now be designed in order to satisfy the two norm inequalities in (A.12) and (A.13). It is readily seen that (A.12) is trivially satisfied for:

$$\mathbf{L} = -\bar{\mathbf{C}}_{2,P} \quad (58)$$

since this solves an (exact) disturbance decoupling problem.

### Lemma 3.4

Let  $\mathbf{P}$  be given by (51) and let  $\mathbf{M} = [\mathbf{M}_1^T \quad \mathbf{M}_2^T]^T$  be any matrix satisfying

$$\| (s\mathbf{I} - \bar{\mathbf{A}}_{P,Q} - \mathbf{M} \bar{\mathbf{C}}_{1,P})^{-1} \bar{\mathbf{E}}_{P,Q} \|_\infty < \gamma / \| \bar{\mathbf{C}}_{2,P} \| \quad (59)$$

Then an admissible controller for the above  $\mathcal{H}_\infty$  problem is given by:

$$\begin{aligned}
 \mathbf{Q}(s) &= [\mathbf{F} \ \mathbf{B}^T \mathbf{P} + \mathbf{F}] \begin{bmatrix} s\mathbf{I} - \mathbf{A} - \mathbf{K}\mathbf{C} - \mathbf{M}_1\mathbf{C} & \mathbf{0} \\ -\mathbf{M}_2\mathbf{C} & s\mathbf{I} - \mathbf{A} + \mathbf{B}\mathbf{B}^T \mathbf{P} \end{bmatrix}^{-1} \begin{bmatrix} \mathbf{M}_1 \\ \mathbf{M}_2 \end{bmatrix} \\
 &= \mathbf{F}(s\mathbf{I} - \mathbf{A} - \mathbf{K}\mathbf{C} - \mathbf{M}_1\mathbf{C})^{-1} \mathbf{M}_1 \\
 &\quad + (\mathbf{B}^T \mathbf{P} + \mathbf{F})s\mathbf{I} - \mathbf{A} + \mathbf{B}\mathbf{B}^T \mathbf{P})^{-1} \mathbf{M}_2 \mathbf{C} (s\mathbf{I} - \mathbf{A} - \mathbf{K}\mathbf{C} - \mathbf{M}_1\mathbf{C})^{-1} \mathbf{M}_1 \\
 &\quad + (\mathbf{B}^T \mathbf{P} + \mathbf{F})(s\mathbf{I} - \mathbf{A} + \mathbf{B}\mathbf{B}^T \mathbf{P})^{-1} \mathbf{M}_2
 \end{aligned} \tag{60}$$

*Proof.* The lemma follows directly by substituting the above matrices in Theorem A.6.

The controller derived in Lemma 3.4 has dynamic order  $2n$ . When inserted in the overall controller structure, as described in Section 2, we get a controller of order  $3n$ , if no reduction is carried out. It turns out, though, that a structural reduction can be performed. The basic idea is to use the remaining freedom in the observer gain  $\mathbf{K}$  designed in Section 2 to obtain some of the desired controller dynamics. This is done by means of a procedure as follows. First a full ( $n$ th)-order observer  $\Sigma_{\text{obs}}$  with any stabilizing gain  $\mathbf{K}$  is designed. Using the Q-observer construction we append a dynamic compensator  $\Sigma_{\mathcal{H}_\infty}$  of order  $2n$  such that the  $\mathcal{H}_\infty$  constraints are satisfied by the overall compensator. Now the original full order observer is returned, allowing for a dynamic compensator  $\Sigma_{\mathcal{H}_\infty}^*$  of order  $n$  to be substituted for  $\Sigma_{\mathcal{H}_\infty}$ , maintaining the same transfer function for the cascade of the two compensators: the modified full order observer  $\Sigma_{\text{obs}}^*$  and the modified  $\mathcal{H}_\infty$  controller  $\Sigma_{\mathcal{H}_\infty}^*$ , as we achieved for the original full order observer  $\Sigma_{\text{obs}}$  cascaded with the  $\mathcal{H}_\infty$  controller  $\Sigma_{\mathcal{H}_\infty}$  — see Figure 4. The validity of the method described above, follows from Theorem 3.5.

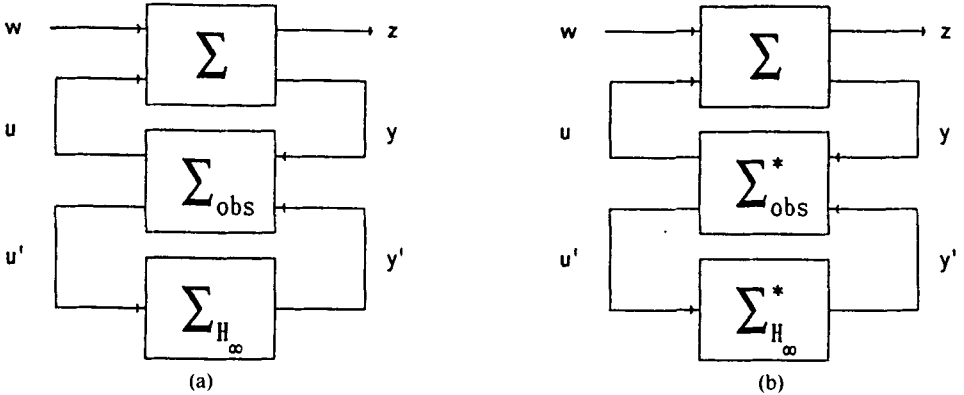

Figure 4. (a) Original system with  $3n$ th-order controller. (b) Transformed system with  $2n$ th-order controller

### Theorem 3.5

Let the transfer function  $\mathbf{Q}^*(s)$  for the output feedback compensator system  $\Sigma_{\mathcal{H}_\infty}^*$  be given by its transfer function  $\mathbf{Q}^*(s) = (\mathbf{B}^T \mathbf{P} + \mathbf{F})(s\mathbf{I} - \mathbf{A} + \mathbf{B}\mathbf{B}^T \mathbf{P})^{-1} \mathbf{M}_2$ . When applying  $\Sigma_{\mathcal{H}_\infty}^*$  to a Q-observer configuration with observer gain  $\mathbf{K}^* = \mathbf{K} + \mathbf{M}_1$  (see Figure 4(b)), the  $\mathcal{H}_\infty$  norm of the transfer function from  $w$  to  $z$  equals the  $\mathcal{H}_\infty$  norm obtained when applying  $\Sigma_{\mathcal{H}_\infty}$  described by (47) to a similar system with observer gain  $\mathbf{K}$ .

*Proof.* Please refer to Appendix C.



In the minimum phase case it can be seen that an  $n$ th-order admissible controller is obtained by choosing  $\mathbf{M}_2 = \mathbf{0}$ .  $\mathbf{M}_1$  must then satisfy:

$$\| (s\mathbf{I} - \mathbf{A} - \mathbf{K}\mathbf{C} - \mathbf{M}_1\mathbf{C})^{-1}\mathbf{B} \|_\infty < \gamma / \| \mathbf{S}_{\text{TFL}}(\cdot)\mathbf{F} \|_\infty \quad (61)$$

which follows directly from the statement of the sensitivity recovery design problem. Luenberger observer parameters in both the minimum phase and the non-minimum phase case is given in the following theorem.

### Theorem 3.6

The cascade of  $\Sigma_{\text{obs}}^*$  and  $\Sigma_{\mathcal{H}_\infty}^*$  (described above) is a Luenberger observer, described by the following matrices:

<i>Non-minimum phase systems:</i>	<i>Minimum phase systems:</i>
$\mathbf{D} = \begin{bmatrix} \mathbf{A} + \mathbf{K}\mathbf{C} + \mathbf{M}_1\mathbf{C} & \mathbf{0} \\ \mathbf{M}_2\mathbf{C} & \mathbf{A} - \mathbf{B}\mathbf{B}^T\mathbf{P} \end{bmatrix}$	$\mathbf{D} = \mathbf{A} + \mathbf{K}\mathbf{C} + \mathbf{M}_1\mathbf{C}$
$\mathbf{G} = \begin{bmatrix} \mathbf{B} \\ \mathbf{0} \end{bmatrix}$	$\mathbf{G} = \mathbf{B}$
$\mathbf{P} = [\mathbf{F} \ \mathbf{B}^T\mathbf{P} + \mathbf{F}]$	$\mathbf{P} = \mathbf{F}$
$\mathbf{E} = \begin{bmatrix} \mathbf{K} + \mathbf{M}_1 \\ \mathbf{M}_2 \end{bmatrix}$	$\mathbf{E} = \mathbf{K} + \mathbf{M}_1$
$\mathbf{V} = \mathbf{0}$	$\mathbf{V} = \mathbf{0}$
$\mathbf{T} = \begin{bmatrix} \mathbf{I} \\ \mathbf{0} \end{bmatrix}$	$\mathbf{T} = \mathbf{I}$

Moreover, the closed loop transfer function obtained by applying this Luenberger observer has  $\mathcal{H}_\infty$  norm smaller than  $\gamma$ .

*Proof.* See Appendix C.

Note that the overall controller is of order  $n$  in the minimum phase case, and  $2n$  in the non-minimum phase case. The reason, why the controller reduction from  $3n$  to  $2n$  is possible, is the remaining freedom in the preliminary observer design. The dynamics from this observer will be cancelled by the  $\mathcal{H}_\infty$  controller and substituted by a more feasible one in the resulting Q-observer structure.

Note that only the output injection  $\mathbf{M}$  in the  $\mathcal{H}_\infty$ /LTR controller depends on  $\gamma$ ;  $\mathbf{L}$  does not.

### 3.3. Sensitivity recovery in the $\mathcal{H}_\infty$ standard formulation

When applying a general controller  $\mathbf{Q}$ ,  $\mathbf{Q} \in \mathcal{RH}_\infty$ , the sensitivity recovery error introduced in Section 2.2 has the form in Section 2.6:

$$\mathbf{E}_s(s) = \mathbf{F}(s\mathbf{I} - \mathbf{A} - \mathbf{B}\mathbf{F})^{-1}\mathbf{B} - \mathbf{Q}(s)(\mathbf{I} - \mathbf{C}(s\mathbf{I} - \mathbf{A})^{-1}\mathbf{B}\mathbf{Q}(s))^{-1}\mathbf{C}(s\mathbf{I} - \mathbf{A})^{-1}\mathbf{B} \quad (62)$$

which is a linear fractional transformation in  $\mathbf{Q}(s)$ .

The state-space formulation equivalent to (62) is:

$$\Sigma_{S,St}: \begin{cases} \dot{\mathbf{x}} = \begin{bmatrix} \mathbf{A} & \mathbf{0} \\ \mathbf{0} & \mathbf{A} + \mathbf{BF} \end{bmatrix} \mathbf{x} + \begin{bmatrix} \mathbf{B} \\ \mathbf{0} \end{bmatrix} \mathbf{u} + \begin{bmatrix} \mathbf{B} \\ \mathbf{B} \end{bmatrix} \mathbf{w} \\ \mathbf{y} = \begin{bmatrix} \mathbf{C} & \mathbf{0} \end{bmatrix} \mathbf{x} + \mathbf{0}\mathbf{w} \\ \mathbf{z} = \begin{bmatrix} \mathbf{0} & \mathbf{F} \end{bmatrix} \mathbf{x} - \mathbf{I}\mathbf{u} \end{cases} \quad (63)$$

or, in short

$$\Sigma_{S,St}: \begin{cases} \dot{\mathbf{x}} = \bar{\mathbf{A}}\mathbf{x} + \bar{\mathbf{B}}\mathbf{u} + \bar{\mathbf{E}}\mathbf{w} \\ \mathbf{y} = \bar{\mathbf{C}}_1\mathbf{x} + \bar{\mathbf{D}}_1\mathbf{w} \\ \mathbf{z} = \bar{\mathbf{C}}_2\mathbf{x} + \bar{\mathbf{D}}_2\mathbf{u} \end{cases} \quad (64)$$

Like the problem in Section 3.2 this is neither a regular nor a totally singular  $\mathcal{H}_\infty$  problem, the state feedback subproblem (the quadratic matrix inequality) is regular and the estimation subproblem (the dual quadratic matrix inequality) is totally singular. In the sequel the structure of the solutions to the quadratic matrix inequality and the dual quadratic matrix inequality will be described as well as the full information and the full control transformations.

### Theorem 3.7

For the system  $\Sigma_{S,St}$  describes by (63), the solution  $\bar{\mathbf{P}}$  of the quadratic matrix inequality is:

$$\bar{\mathbf{P}} = \begin{bmatrix} \mathbf{P} & -\mathbf{P} \\ -\mathbf{P} & \mathbf{P} \end{bmatrix} \quad (65)$$

where  $\mathbf{P}$  is given in Theorem 3.1. The associated quadratic matrix becomes:

$$\bar{\mathbf{F}}_\gamma(\bar{\mathbf{P}}) = \begin{bmatrix} -\mathbf{PB} \\ \mathbf{PB} + \mathbf{F}^T \\ -\mathbf{I} \end{bmatrix} \times [-\mathbf{B}^T\mathbf{P} \quad \mathbf{B}^T\mathbf{P} + \mathbf{F} \quad -\mathbf{I}] \quad (66)$$

*Proof.* See Appendix D.

Note that solvability of, and the solution to, the quadratic matrix inequality does not depend on  $\gamma$ . Hence solvability of the  $\mathcal{H}_\infty$  problem is equivalent to solvability of the transformed dual quadratic matrix inequality below.

From Appendix A we achieve the following matrices associated with the  $\mathcal{H}_\infty$  problem (63–64) by the full information transformation:

$$\begin{aligned} \bar{\mathbf{A}}_P &= \bar{\mathbf{A}} \\ \bar{\mathbf{C}}_P &= \bar{\mathbf{C}}_1 \\ \bar{\mathbf{C}}_{2,P} &= [-\mathbf{B}^T\mathbf{P} \quad \mathbf{B}^T\mathbf{P} + \mathbf{F}] \\ \bar{\mathbf{D}}_P &= \bar{\mathbf{D}}_2 \end{aligned} \quad (67)$$

Now, the dual version of Corollary A.4 can be applied to the full information transform of the original system to obtain of the dual quadratic matrix inequality.

### Lemma 3.8

For the system described by (63) with the modified matrices given by (67) the solution to the

dual quadratic matrix inequality:

$$\bar{\mathbf{Y}} = \begin{bmatrix} \mathbf{Y}_{11} & \mathbf{Y}_{12} \\ \mathbf{Y}_{12}^T & \mathbf{Y}_{22} \end{bmatrix} \quad (68)$$

satisfies

$$\mathbf{C}\mathbf{Y}_{11} = \mathbf{0} \quad \text{and} \quad \mathbf{C}\mathbf{Y}_{12} = \mathbf{0}$$

in addition to the conditions (4) and (6) of Theorem A.2.  $\bar{G}_\gamma(\bar{\mathbf{Y}})$  factorizes as:

$$\bar{G}_\gamma(\bar{\mathbf{Y}}) = \begin{bmatrix} \bar{\mathbf{E}}_{P,Q} \\ \mathbf{0} \end{bmatrix} \times [\bar{\mathbf{E}}_{P,Q}^T \quad \mathbf{0}] \quad (69)$$

This time the special case  $\bar{\mathbf{Y}} = \mathbf{0}$  appears in the following situation:

### Corollary 3.9

Assume that the system  $(\mathbf{A}, \mathbf{B}, \mathbf{C}, \mathbf{0})$  is invertible and minimum phase. Then  $\bar{\mathbf{Y}} = \mathbf{0}$  is a solution to the dual quadratic matrix inequality, satisfying the involved rank conditions.

*Proof.* Equivalent to the proof of Corollary 3.3.

For  $\bar{\mathbf{Y}} \neq \mathbf{0}$  the full control transformation proceeds as follows:

$$\bar{\mathbf{A}}_{P,Q} = \bar{\mathbf{A}} + \gamma^{-2} \bar{\mathbf{Y}} \bar{\mathbf{C}}_{2,P}^T \bar{\mathbf{C}}_{2,P} = \begin{bmatrix} \mathbf{A}_{P,Q}^{11} & \mathbf{A}_{P,Q}^{12} \\ \mathbf{A}_{P,Q}^{21} & \mathbf{A}_{P,Q}^{22} \end{bmatrix} \quad (70)$$

with:

$$\begin{aligned} \mathbf{A}_{P,Q}^{11} &= \mathbf{A} + \gamma^{-2} (\mathbf{Y}_{11} - \mathbf{Y}_{12}) \mathbf{P} \mathbf{B} \mathbf{B}^T \mathbf{P} - \gamma^{-2} \mathbf{Y}_{12} \mathbf{F}^T \mathbf{B}^T \mathbf{P} \\ \mathbf{A}_{P,Q}^{21} &= \gamma^{-2} (\mathbf{Y}_{12}^T - \mathbf{Y}_{22}) \mathbf{P} \mathbf{B} \mathbf{B}^T \mathbf{P} - \gamma^{-2} \mathbf{Y}_{22} \mathbf{F}^T \mathbf{B}^T \mathbf{P} \\ \mathbf{A}_{P,Q}^{12} &= \gamma^{-2} (\mathbf{Y}_{12} - \mathbf{Y}_{11}) (\mathbf{P} \mathbf{B} \mathbf{B}^T \mathbf{P} + \mathbf{P} \mathbf{B} \mathbf{F}) + \gamma^{-2} \mathbf{Y}_{12} (\mathbf{F}^T \mathbf{B}^T \mathbf{P} + \mathbf{F}^T \mathbf{F}) \\ \mathbf{A}_{P,Q}^{22} &= \mathbf{A}_F + \gamma^{-2} (\mathbf{Y}_{22} - \mathbf{Y}_{12}^T) (\mathbf{P} \mathbf{B} \mathbf{B}^T \mathbf{P} + \mathbf{P} \mathbf{B} \mathbf{F}) + \gamma^{-2} \mathbf{Y}_{22} (\mathbf{F}^T \mathbf{B}^T \mathbf{P} + \mathbf{F}^T \mathbf{F}) \\ \bar{\mathbf{B}}_{P,Q} &= \bar{\mathbf{B}} + \gamma^{-2} \bar{\mathbf{Y}} \bar{\mathbf{C}}_{2,P}^T \bar{\mathbf{D}}_P = \begin{bmatrix} \mathbf{B} + \gamma^{-2} (\mathbf{Y}_{11} - \mathbf{Y}_{12}) \mathbf{P} \mathbf{B} - \gamma^{-2} \mathbf{Y}_{12} \mathbf{F}^T \\ -\gamma^{-2} (\mathbf{Y}_{12}^T - \mathbf{Y}_{22}) \mathbf{P} \mathbf{B} - \gamma^{-2} \mathbf{Y}_{22} \mathbf{F}^T \end{bmatrix} \end{aligned} \quad (71)$$

After these two transformations, the final controller  $\mathbf{Q}(s)$  can be designed directly, by means of solutions to the two norm inequalities given by (A.12) and (A.13). It is readily seen that (A.12) is trivially satisfied for:

$$\mathbf{L} = [-\mathbf{B}^T \mathbf{P} \quad \mathbf{B}^T \mathbf{P} + \mathbf{F}] \quad (72)$$

since this choice solves an (exact) disturbance decoupling problem.

### Lemma 3.10

Let  $\mathbf{P}$  be as above and let  $\mathbf{M} = [\mathbf{M}_1^T \quad \mathbf{M}_2^T]^T$  be an output injection satisfying:

$$\| (s\mathbf{I} - \bar{\mathbf{A}}_{P,Q} - \mathbf{M} \bar{\mathbf{C}}_1)^{-1} \bar{\mathbf{E}}_{P,Q} \|_\infty < \gamma / \| \bar{\mathbf{C}}_{2,P} \| \quad (73)$$

Then an admissible controller for the above  $\mathcal{H}_\infty$  problem is given by:

$$\mathbf{Q}(s) = - [-\mathbf{B}^T \mathbf{P} \quad \mathbf{B}^T \mathbf{P} + \mathbf{F}] \begin{bmatrix} s\mathbf{I} - \mathbf{A} + \mathbf{B} \mathbf{B}^T \mathbf{P} - \mathbf{M}_1 \mathbf{C} & -\mathbf{B} \mathbf{B}^T \mathbf{P} - \mathbf{B} \mathbf{F} \\ -\mathbf{M}_2 \mathbf{C} & s\mathbf{I} - \mathbf{A} - \mathbf{B} \mathbf{F} \end{bmatrix}^{-1} \begin{bmatrix} \mathbf{M}_1 \\ \mathbf{M}_2 \end{bmatrix} \quad (74)$$

*Proof.* Lemma 3.10 follows by substituting the above matrices in the expression of Theorem A.5. The relaxed norm bound in (73) (compared to (A.12)) is achieved by exploiting that  $\mathbf{L}$  solves an exact disturbance decoupling problem.

Note that the controller depends on  $\bar{\mathbf{Y}}$  only indirectly (through  $\mathbf{M}$ ).

As in Section 3.2 it is possible to obtain an  $n$ th-order controller if the system  $(\mathbf{A}, \mathbf{B}, \mathbf{C}, \mathbf{0})$  is invertible and minimum phase. The following controller results from substituting  $\bar{\mathbf{Y}} = \mathbf{0}$  in Theorem A.5.

#### Lemma 3.11

Assume that  $\bar{\mathbf{Y}} = \mathbf{0}$  is the solution to the dual quadratic matrix inequality. Then an admissible controller for the above  $\mathcal{H}_\infty$  problem is given by:

$$\mathbf{Q}(s) = \mathbf{F}(s\mathbf{I} - \mathbf{A} - \mathbf{BF} - \mathbf{NC})^{-1}\mathbf{N} \quad (75)$$

where  $\mathbf{N}$  makes  $\mathbf{A} + \mathbf{NC}$  stable and further satisfies:

$$\| (s\mathbf{I} - \mathbf{A} - \mathbf{NC})^{-1}\mathbf{B} \|_\infty < \gamma / \| \mathbf{S}_{\text{TFL}}(\cdot)\mathbf{F} \|_\infty \quad (76)$$

*Proof.* See Appendix D.

## 4. THE INPUT-OUTPUT $\mathcal{H}_\infty$ /LTR DESIGN PROBLEM

In this section we shall consider the input-output recovery problem with an  $\mathcal{H}_\infty$  optimality criterion. As in Section 3, two different approaches will be taken. In Section 4.1 the  $\mathcal{H}_\infty$  problem is treated by the Q-observer formulation from Section 2, Problem 4. In Section 4.2 the problem is formulated with no constraints on the imposed controller type, the standard  $\mathcal{H}_\infty$  setup (Problem 5).

### 4.1. Input-output recovery using the Q-observer

With the Q-observer structure introduced in Section 2, the input-output recovery error becomes:

$$\mathbf{E}_{\text{IO}}(s) = \mathbf{G}_{\text{TFL}}(s)\mathbf{M}_{\text{I}}(s) = \mathbf{C}(s\mathbf{I} - \mathbf{A} - \mathbf{BF})^{-1}\mathbf{B}(\mathbf{F}(s\mathbf{I} - \mathbf{A} - \mathbf{KC})^{-1}\mathbf{B} + \mathbf{Q}(s)\mathbf{C}(s\mathbf{I} - \mathbf{A} - \mathbf{KC})^{-1}\mathbf{B}) \quad (77)$$

The state-space model of the input-output recovery error transfer function is:

$$\Sigma_{\text{IO,Q}}: \begin{cases} \dot{\mathbf{x}} = \begin{bmatrix} \mathbf{A} + \mathbf{KC} & \mathbf{0} \\ \mathbf{BF} & \mathbf{A} + \mathbf{BF} \end{bmatrix} \mathbf{x} + \begin{bmatrix} \mathbf{0} \\ \mathbf{B} \end{bmatrix} \mathbf{u} + \begin{bmatrix} \mathbf{B} \\ \mathbf{0} \end{bmatrix} \mathbf{w} \\ \mathbf{y} = \begin{bmatrix} \mathbf{C} & \mathbf{0} \end{bmatrix} \mathbf{x} + \mathbf{0}\mathbf{w} \\ \mathbf{z} = \begin{bmatrix} \mathbf{0} & \mathbf{C} \end{bmatrix} \mathbf{x} + \mathbf{0}\mathbf{u} \end{cases} \quad (78)$$

or, in short

$$\Sigma_{\text{IO,Q}}: \begin{cases} \dot{\mathbf{x}} = \bar{\mathbf{A}}\mathbf{x} + \bar{\mathbf{B}}\mathbf{u} + \bar{\mathbf{E}}\mathbf{w} \\ \mathbf{y} = \bar{\mathbf{C}}_1\mathbf{x} + \bar{\mathbf{D}}_1\mathbf{w} \\ \mathbf{z} = \bar{\mathbf{C}}_2\mathbf{x} + \bar{\mathbf{D}}_2\mathbf{u} \end{cases} \quad (79)$$

The corresponding  $\mathcal{H}_\infty$  problem is seen to be totally singular. Now, following the line of Section 3.1, the solutions to the quadratic matrix inequality and the dual quadratic matrix inequality are found, using Corollary A.4 and the associated transformations. For the quadratic matrix inequality we have the following.

*Theorem 4.1*

The quadratic matrix inequality associated with the system  $\Sigma_{10,Q}$  has the solution

$$\bar{\mathbf{P}} = \begin{bmatrix} \mathbf{0} & \mathbf{0} \\ \mathbf{0} & \mathbf{P} \end{bmatrix} \quad (80)$$

where  $\mathbf{P}$  is the unique matrix satisfying:

- (i)  $\mathbf{A}^T \mathbf{P} + \mathbf{P} \mathbf{A} + \mathbf{C}^T \mathbf{C} = \mathbf{C}_{2,P}^T \mathbf{C}_{2,P} \geq \mathbf{0}$
- (ii)  $\mathbf{P} \mathbf{B} = \mathbf{0}$
- (iii)  $\text{rank}(\mathbf{A}^T \mathbf{P} + \mathbf{P} \mathbf{A} + \mathbf{C}^T \mathbf{C}) = \text{normrank } \mathbf{G}(s)$  (81)
- (iv)  $\text{rank} \begin{bmatrix} s\mathbf{I} - \mathbf{A} & -\mathbf{B} \\ \mathbf{C}_{2,P} & \mathbf{0} \end{bmatrix} = n + \text{normrank } \mathbf{G}(s), \forall s \in \bar{\mathbf{C}}^+$

with  $\mathbf{G}(s) = \mathbf{C}(s\mathbf{I} - \mathbf{A} - \mathbf{B}\mathbf{F})^{-1}\mathbf{B}$ .

*Proof.* See Appendix E.

Note, that the quadratic matrix inequality in this case reduces to a dissipation inequality (known from classical LQG theory, see for example, Reference 7) of  $n$ th order. This equation can be solved by a much simplified version of the algorithm in Appendix B.

Also in the case the solution of the quadratic matrix inequality is independent of  $\gamma$ . Solvability of the  $\mathcal{H}_\infty$ /LTR problem will effectively depend only on solvability of the transformed dual quadratic matrix inequality.

As a consequence of Theorem 4.1 we have the following corollary.

*Corollary 4.2*

Assume that  $(\mathbf{A}, \mathbf{B}, \mathbf{C}, \mathbf{0})$  is minimum phase. Then  $\bar{\mathbf{P}} = \mathbf{0}$  is the unique solution to the quadratic matrix inequality. Conversely, if  $\bar{\mathbf{P}} = \mathbf{0}$  solves the quadratic matrix inequality (and the associated rank conditions),  $(\mathbf{A}, \mathbf{B}, \mathbf{C}, \mathbf{0})$  is minimum phase.

*Proof.* Corollary 4.2 follows directly from Theorem 4.1.

In general, however, the full information transformation (see Appendix A) will be non-trivial, and amount to:

$$\begin{aligned} \bar{\mathbf{A}}_P &= \hat{\mathbf{A}} \\ \bar{\mathbf{C}}_{1,P} &= \bar{\mathbf{C}}_1 \\ \bar{\mathbf{C}}_{2,P} &= [\mathbf{0} \quad \mathbf{C}_{2,p}] \end{aligned} \quad (82)$$

On this system, obtained by the full information transformation, the dual version of Corollary A.4 can now be applied to derive the solution of the dual quadratic matrix inequality.

**Lemma 4.3**

For the dual quadratic matrix inequality associated with the system  $\Sigma_{10,Q}$  with matrices modified as in (82), the solution:

$$\bar{\mathbf{Y}} = \begin{bmatrix} \mathbf{Y}_{11} & \mathbf{Y}_{12} \\ \mathbf{Y}_{12}^T & \mathbf{Y}_{22} \end{bmatrix} \text{ satisfies: } \mathbf{C}\mathbf{Y}_{11} = \mathbf{0} \quad \text{and} \quad \mathbf{C}\mathbf{Y}_{12} = \mathbf{0} \quad (83)$$

in addition to the conditions (4) and (6) of Theorem A.2.  $\bar{\mathbf{G}}_\gamma(\bar{\mathbf{Y}})$  factorizes as:

$$\bar{\mathbf{G}}_\gamma(\bar{\mathbf{Y}}) = \begin{bmatrix} \bar{\mathbf{E}}_{P,Q} \\ \mathbf{0} \end{bmatrix} \times [\bar{\mathbf{E}}_{P,Q}^T \quad \mathbf{0}] \quad (84)$$

*Proof.* The proof of Lemma 4.3 proceeds exactly as the proof of Lemma 3.2.

As in the sensitivity recovery error case, it will be possible to simplify the solution of the dual quadratic matrix inequality in special cases, as it appears from the following Corollary.

**Corollary 4.4**

If (and only if) the system  $(\mathbf{A}, \mathbf{B}, \mathbf{C}, \mathbf{0})$  is minimum phase and invertible,  $\bar{\mathbf{Y}} = \mathbf{0}$  is a solution to the transformed dual quadratic matrix inequality.

More generally, though, the full control transformation will result in the following matrices:

$$\bar{\mathbf{A}}_{P,Q} = \begin{bmatrix} \mathbf{A} + \mathbf{K}\mathbf{C} & \gamma^{-2}\mathbf{Y}_{12}\mathbf{C}_{2,P}^T\mathbf{C}_{2,P} \\ \mathbf{B}\mathbf{F} & \mathbf{A} + \mathbf{B}\mathbf{F} + \gamma^{-2}\mathbf{Y}_{22}\mathbf{C}_{2,P}^T\mathbf{C}_{2,P} \end{bmatrix} \quad \text{and} \quad \bar{\mathbf{B}}_{P,Q} = \bar{\mathbf{B}} \quad (85)$$

Performing both transformations, we eventually obtain the controller, solving the  $\mathcal{H}_\infty$  problem.

**Lemma 4.5**

Assume that  $\gamma$  has been chosen sufficiently large. Let  $\mathbf{L} = [\mathbf{L}_1 \quad \mathbf{L}_2]$  be a state feedback satisfying (A.12) and let  $\mathbf{M} = [\mathbf{M}_1^T \quad \mathbf{M}_2^T]^T$  be an output injection satisfying (A.13). Then a controller, making the closed loop internally stable, and making the  $\mathcal{H}_\infty$  norm of the transfer from  $w$  to  $z$  smaller than  $\gamma$  is given by:

$$\mathbf{Q}(s) = -[\mathbf{L}_1 \quad \mathbf{L}_2] \times \begin{bmatrix} s\mathbf{I} - \mathbf{A} - \mathbf{K}\mathbf{C} - \mathbf{M}_1\mathbf{C} & -\gamma^{-2}\mathbf{Y}_{12}\mathbf{C}_{2,P}^T\mathbf{C}_{2,P} \\ -\mathbf{B}\mathbf{F} - \mathbf{B}\mathbf{L}_1 - \mathbf{M}_2\mathbf{C} & s\mathbf{I} - \mathbf{A} - \mathbf{B}\mathbf{F} - \gamma^{-2}\mathbf{Y}_{22}\mathbf{C}_{2,P}^T\mathbf{C}_{2,P} - \mathbf{B}\mathbf{L}_2 \end{bmatrix}^{-1} \times \begin{bmatrix} \mathbf{M}_1 \\ \mathbf{M}_2 \end{bmatrix} \quad (86)$$

Moreover, whenever a solution exists, it can be seen that  $\mathbf{L}$  might always be chosen as  $\mathbf{L} = [-\mathbf{F} \quad \mathbf{L}_2]$ . Hence, the problem can always be solved by applying a controller of the form:

$$\mathbf{Q}(s) = [\mathbf{F} \quad -\mathbf{L}_2] \times \begin{bmatrix} s\mathbf{I} - \mathbf{A} - \mathbf{K}\mathbf{C} - \mathbf{M}_1\mathbf{C} & -\gamma^{-2}\mathbf{Y}_{12}\mathbf{C}_{2,P}^T\mathbf{C}_{2,P} \\ -\mathbf{M}_2\mathbf{C} & s\mathbf{I} - \mathbf{A} - \mathbf{B}\mathbf{F} - \gamma^{-2}\mathbf{Y}_{22}\mathbf{C}_{2,P}^T\mathbf{C}_{2,P} - \mathbf{B}\mathbf{L}_2 \end{bmatrix}^{-1} \times \begin{bmatrix} \mathbf{M}_1 \\ \mathbf{M}_2 \end{bmatrix} \quad (87)$$

*Proof.* (86) follows directly from Theorem A.5.  $\mathbf{L}_1 = -\mathbf{F}$  is proven in Appendix E.

The Q-term, given by (87), of the controller is of dynamic order  $2n$ , which means that the complete controller will be of order  $3n$ . In Section 3 it was possible by careful selection of the preliminary observer gain  $\mathbf{K}$  to obtain a  $2n$ th-order controller. Also for the IO-recovery problem, if the preliminary full order observer gain had been chosen as  $\mathbf{K}^* = \mathbf{K} + \mathbf{M}_1$  rather than  $\mathbf{K}$ , it can be shown that the resulting controller with  $3n$  controller states would have had a transfer function of dynamic order  $2n$  (when selecting  $\mathbf{M} = [\mathbf{0} \ \mathbf{M}_2^T]^T$  which is admissible in this case). In Section 3 this  $2n$ th-order transfer function could itself be implemented as a Q-observer with an  $n$ th-order Q-term. This is not possible for the IO-recovery problem. However, the  $2n$ th-order transfer function can still be implemented as a Luenberger observer based controller, whose parameters are given in Theorem 4.6. In the minimum phase case,  $\mathbf{M}_2 = \mathbf{0}$  is an admissible choice which reduces the order of the controller to  $n$ . The minimum phase controller is now obtained by selecting  $\mathbf{M}_1$  such that:

$$\|(s\mathbf{I} - \mathbf{A} - \mathbf{K}\mathbf{C} - \mathbf{M}_1\mathbf{C})^{-1}\mathbf{B}\|_\infty < \gamma(\|\mathbf{G}_{\text{TFL}}(\cdot)\mathbf{F}\|_\infty)^{-1} \quad (88)$$

This is verified directly from the definition of the input-output recovery problem. The minimum phase controller can be implemented as a full order observer based controller with observer gain  $\mathbf{K}^*$ . In comparison we have:

#### Theorem 4.6

The Luenberger observer based controller with the following characteristic matrices is internally stabilizing and makes the  $\mathcal{H}_\infty$  norm of  $\mathbf{E}_{\text{IO}}(\cdot)$  smaller than  $\gamma$ :

*Non-minimum phase systems:*

$$\mathbf{D} = \begin{bmatrix} \mathbf{A} + \mathbf{K}\mathbf{C} + \mathbf{M}_1\mathbf{C} & \gamma^{-2}\mathbf{Y}_{12}\mathbf{C}_{2,P}^T\mathbf{C}_{2,P} \\ \mathbf{M}_2\mathbf{C} & \mathbf{A} + \mathbf{B}\mathbf{F} + \mathbf{B}\mathbf{L}_2 + \gamma^{-2}\mathbf{Y}_{22}\mathbf{C}_{2,P}^T\mathbf{C}_{2,P} \end{bmatrix}$$

$$\mathbf{G} = \begin{bmatrix} \mathbf{B} \\ \mathbf{0} \end{bmatrix}$$

$$\mathbf{P} = [\mathbf{F} \quad -\mathbf{L}_2]$$

$$\mathbf{E} = \begin{bmatrix} \mathbf{K} + \mathbf{M}_1 \\ \mathbf{M}_2 \end{bmatrix}$$

$$\mathbf{V} = \mathbf{0}$$

$$\mathbf{T} = \begin{bmatrix} \mathbf{I} \\ \mathbf{0} \end{bmatrix}$$

*Minimum phase systems:*

$$\mathbf{D} = \mathbf{A} + \mathbf{K}\mathbf{C} + \mathbf{M}_1\mathbf{C}$$

$$\mathbf{G} = \mathbf{B}$$

$$\mathbf{P} = \mathbf{F}$$

$$\mathbf{E} = \mathbf{K} + \mathbf{M}_1$$

$$\mathbf{V} = \mathbf{0}$$

$$\mathbf{T} = \mathbf{I}$$

This Luenberger observer based controller, when applied to the system described by (78) makes the  $\mathcal{H}_\infty$  norm of the closed loop transfer function from  $\mathbf{w}$  to  $\mathbf{z}$  smaller than  $\gamma$ .

*Proof.* The proof is given in Appendix E.

#### 4.2. Input-output recovery in the $\mathcal{H}_\infty$ standard formulation

When applying a general controller  $\mathbf{Q}$ ,  $\mathbf{Q} \in \mathcal{RH}_\infty$ , the input-output recovery error introduced in Section 2.2 has the form:

$$\begin{aligned} \mathbf{E}_{\text{IO}} = & \mathbf{C}(s\mathbf{I} - \mathbf{A} - \mathbf{B}\mathbf{F})^{-1}\mathbf{B} - \mathbf{C}(s\mathbf{I} - \mathbf{A})^{-1}\mathbf{B} \\ & - \mathbf{C}(s\mathbf{I} - \mathbf{A})^{-1}\mathbf{B}\mathbf{Q}(s)(\mathbf{I} - \mathbf{C}(s\mathbf{I} - \mathbf{A})^{-1}\mathbf{B}\mathbf{Q}(s))^{-1}\mathbf{C}(s\mathbf{I} - \mathbf{A})^{-1}\mathbf{B} \end{aligned} \quad (89)$$

which is again a linear fraction transformation in  $Q(s)$ . The state-space formulation equivalent to (89) is:

$$\Sigma_{10,St}: \begin{cases} \dot{\mathbf{x}} = \begin{bmatrix} \mathbf{A} & \mathbf{0} \\ \mathbf{0} & \mathbf{A} + \mathbf{BF} \end{bmatrix} \mathbf{x} + \begin{bmatrix} \mathbf{B} \\ \mathbf{0} \end{bmatrix} \mathbf{u} + \begin{bmatrix} \mathbf{B} \\ \mathbf{B} \end{bmatrix} \mathbf{w} \\ \mathbf{y} = \begin{bmatrix} \mathbf{C} & \mathbf{0} \end{bmatrix} \mathbf{x} + \mathbf{0}\mathbf{w} \\ \mathbf{z} = \begin{bmatrix} -\mathbf{C} & \mathbf{C} \end{bmatrix} \mathbf{x} + \mathbf{0}\mathbf{u} \end{cases} \quad (90)$$

or, in short

$$\Sigma_{10,St}: \begin{cases} \dot{\mathbf{x}} = \bar{\mathbf{A}}\mathbf{x} + \bar{\mathbf{B}}\mathbf{u} + \bar{\mathbf{E}}\mathbf{w} \\ \mathbf{y} = \bar{\mathbf{C}}_1\mathbf{x} + \bar{\mathbf{D}}_1\mathbf{w} \\ \mathbf{z} = \bar{\mathbf{C}}_2\mathbf{x} + \bar{\mathbf{D}}_2\mathbf{u} \end{cases} \quad (91)$$

Thus, the  $\mathcal{H}_\infty$  problem to be considered in the following is again totally singular, and consequently Corollary A.4 can be applied to solve the associated quadratic matrix inequality and the dual quadratic matrix inequality.

*Theorem 4.7*

Consider the system  $\Sigma_{10,St}$  given by (90). The solution  $\bar{\mathbf{P}}$  to the associated quadratic matrix inequality has the following form:

$$\bar{\mathbf{P}} = \begin{bmatrix} \mathbf{P} & -\mathbf{P} \\ -\mathbf{P} & \mathbf{P} \end{bmatrix} \quad (92)$$

where  $\mathbf{P}$  is given by Theorem 4.1.

The full information transformation (see Appendix A) corresponding to Theorem 4.7 becomes:

$$\begin{aligned} \bar{\mathbf{A}}_P &= \bar{\mathbf{A}} \\ \bar{\mathbf{C}}_{1,P} &= \bar{\mathbf{C}}_1 \\ \bar{\mathbf{C}}_{2,P} &= [\mathbf{C}_{2,P} \quad -\mathbf{C}_{2,P}] \end{aligned} \quad (93)$$

where  $\mathbf{C}_{2,P}$  is given as a square root by:

$$\bar{\mathbf{F}}_\gamma(\bar{\mathbf{P}}) = \begin{bmatrix} \mathbf{C}_{2,P}^T \\ -\mathbf{C}_{2,P}^T \\ \mathbf{0} \end{bmatrix} \times [\mathbf{C}_{2,P} \quad -\mathbf{C}_{2,P} \quad \mathbf{0}] \quad (94)$$

*Proof.* See Appendix F.

When  $\bar{\mathbf{P}} = \mathbf{0}$  or  $\bar{\mathbf{Y}} = \mathbf{0}$  are solutions to the quadratic matrix inequality or the dual quadratic matrix inequality, resp., the associated rank conditions are satisfied in the following case:

*Lemma 4.8*

Assume that the system  $(\mathbf{A}, \mathbf{B}, \mathbf{C}, \mathbf{0})$  is minimum phase. Then  $\bar{\mathbf{P}} = \mathbf{0}$  is the unique solution to the quadratic matrix inequality satisfying the involved rank conditions. Further if  $(\mathbf{A}, \mathbf{B}, \mathbf{C}, \mathbf{0})$  is also invertible, then  $\bar{\mathbf{Y}} = \mathbf{0}$  is the unique solution to the dual quadratic matrix inequality satisfying the two rank conditions.



*Proof.* Follows from Theorem 4.7 and Theorem A.2.

These conditions are exactly the same as the conditions derived in Section 4.1. For non-trivial transformations we obtain the following matrices for the transformed system:

$$\bar{\mathbf{A}}_{P,Q} = \begin{bmatrix} \mathbf{A}_{P,Q}^{11} & \mathbf{A}_{P,Q}^{12} \\ \mathbf{A}_{P,Q}^{21} & \mathbf{A}_{P,Q}^{22} \end{bmatrix}$$

where:

$$\begin{aligned} \mathbf{A}_{P,Q}^{11} &= \mathbf{A} + \gamma^{-2}(\mathbf{Y}_{11} - \mathbf{Y}_{12})\mathbf{C}_{2,P}^T\mathbf{C}_{2,P} \\ \mathbf{A}_{P,Q}^{12} &= \gamma^{-2}(\mathbf{Y}_{12} - \mathbf{Y}_{11})\mathbf{C}_{2,P}^T\mathbf{C}_{2,P} \\ \mathbf{A}_{P,Q}^{21} &= \gamma^{-2}(\mathbf{Y}_{12}^T - \mathbf{Y}_{22})\mathbf{C}_{2,P}^T\mathbf{C}_{2,P} \\ \mathbf{A}_{P,Q}^{22} &= \mathbf{A} + \mathbf{B}\mathbf{F} + \gamma^{-2}(\mathbf{Y}_{22} - \mathbf{Y}_{12}^T)\mathbf{C}_{2,P}^T\mathbf{C}_{2,P} \\ \bar{\mathbf{B}}_{P,Q} &= \bar{\mathbf{B}} \\ \bar{\mathbf{E}}_{P,Q} &= \begin{bmatrix} \mathbf{E}_{P,Q}^1 \\ \mathbf{E}_{P,Q}^2 \end{bmatrix} \\ \bar{\mathbf{C}}_{1,P} &= \bar{\mathbf{C}}_1 \\ \bar{\mathbf{C}}_{2,P} &= [\mathbf{C}_{2,P} \quad -\mathbf{C}_{2,P}] \end{aligned} \quad (95)$$

Eventually, an admissible controller, solving the  $\mathcal{H}_\infty$  problem is obtained in terms of these transformed matrices.

#### Lemma 4.9

Let  $\mathbf{L} = [\mathbf{L}_1 \quad \mathbf{L}_2]$  be a state feedback satisfying (A.12) and let  $\mathbf{M} = [\mathbf{M}_1^T \quad \mathbf{M}_2^T]^T$  be an output injection satisfying (A.13). Then, an internally stabilizing controller, making the  $\mathcal{H}_\infty$  norm of the closed loop transfer function from  $\mathbf{w}$  to  $\mathbf{z}$  smaller than  $\gamma$  is given by:

$$\mathbf{Q}(s) = [\mathbf{L}_1 \quad \mathbf{L}_2] \times \begin{bmatrix} s\mathbf{I} - \mathbf{A}_{P,Q}^{11} - \mathbf{B}\mathbf{L}_1 - \mathbf{M}_1\mathbf{C} & -\mathbf{A}_{P,Q}^{12} - \mathbf{B}\mathbf{L}_2 \\ -\mathbf{A}_{P,Q}^{21} - \mathbf{M}_2\mathbf{C} & s\mathbf{I} - \mathbf{A}_{P,Q}^{22} \end{bmatrix}^{-1} \times \begin{bmatrix} \mathbf{M}_1 \\ \mathbf{M}_2 \end{bmatrix} \quad (96)$$

*Proof.* Lemma 4.9 follows from (A.14).

In the case where the transfer function  $\mathbf{C}(s\mathbf{I} - \mathbf{A})^{-1}\mathbf{B}$  is minimum phase and square with full rank, then  $\bar{\mathbf{P}} = \bar{\mathbf{Y}} = \mathbf{0}$  and we have the following controller reduction.

#### Lemma 4.10

Assume that  $\bar{\mathbf{P}} = \mathbf{0}$  and  $\bar{\mathbf{Y}} = \mathbf{0}$  are the solutions to the quadratic matrix inequality and the dual quadratic matrix inequality, respectively. Then an admissible controller for the above  $\mathcal{H}_\infty$  problem is given by:

$$\mathbf{Q}(s) = \mathbf{F}(s\mathbf{I} - \mathbf{A} - \mathbf{B}\mathbf{F} - \mathbf{N}\mathbf{C})^{-1}\mathbf{N} \quad (97)$$

where  $\mathbf{N}$  satisfies:

$$\| (s\mathbf{I} - \mathbf{A} - \mathbf{N}\mathbf{C})^{-1}\mathbf{B} \|_\infty < \gamma / \| \mathbf{G}_{\text{IO}}(\cdot)\mathbf{F} \|_\infty \quad (98)$$

with  $\mathbf{A} + \mathbf{N}\mathbf{C}$  stable.

*Proof.* See Appendix F.

5. SUMMARY OF  $\mathcal{H}_\infty$ /LTR CONTROLLERS

In this section we shall give a brief comparison of the order of the  $\mathcal{H}_\infty$ /LTR controllers elaborated in the previous two sections.

In Table I, the solutions to the quadratic matrix inequality (QMI) are compared for the four  $\mathcal{H}_\infty$ /LTR problems from Sections 3 and 4. Note, that the solutions to the four quadratic matrix inequalities are very intimately related. The  $\bar{\mathbf{P}}$  solution for the Q-observer has the same structure for both the sensitivity and the input-output recovery problem, and equivalently for the standard  $\mathcal{H}_\infty$  setup. Moreover the  $\mathbf{P}$  parameter satisfies the same  $n$ th-order Riccati equation for both controller types in the sensitivity recovery case. Equivalently, for the input-output recovery case, the  $\mathbf{P}$  parameter satisfies the same  $n$ th-order dissipation inequality for both controller types. The conditions for the special solutions  $\bar{\mathbf{P}} = \mathbf{0}$ , respectively  $\bar{\mathbf{Y}} = \mathbf{0}$ , are the same for both controller types in the sensitivity recovery case. Equivalently for the input-output recovery case.

In Table II the sufficient controller orders are given for the solutions to the five  $\mathcal{H}_\infty$ /LTR problems given in Section 2.7.

In general, the question of determining the minimal order of an admissible  $\mathcal{H}_\infty$  controller, is answered by means of careful parameter selection, and subsequent application of model reduction techniques. There are, though, special cases where an  $n$ th-order standard observer based controller suffices for structural reasons [23].

Let us consider the sensitivity recovery error. We define the following two bounds:

$$\gamma_{2n}^* = \inf_{\mathcal{E}_{2n}} \|\mathbf{E}_S\|_\infty \tag{99}$$

Table I. Solutions to the quadratic matrix inequality (QMI)

QMI solution	$\mathbf{E}_S$	$\mathbf{E}_{IO}$
Q-observer based controller	$\bar{\mathbf{P}} = \begin{bmatrix} \mathbf{0} & \mathbf{0} \\ \mathbf{0} & \mathbf{P} \end{bmatrix}$	$\bar{\mathbf{P}} = \begin{bmatrix} \mathbf{0} & \mathbf{0} \\ \mathbf{0} & \mathbf{P} \end{bmatrix}$
General controller	$\bar{\mathbf{P}} = \begin{bmatrix} \mathbf{P} & -\mathbf{P} \\ -\mathbf{P} & \mathbf{P} \end{bmatrix}$	$\bar{\mathbf{P}} = \begin{bmatrix} \mathbf{P} & -\mathbf{P} \\ -\mathbf{P} & \mathbf{P} \end{bmatrix}$
Where $\mathbf{P}$ satisfies:	Sing. Riccati equation: $\mathbf{A}^T \mathbf{P} + \mathbf{P} \mathbf{A} - \mathbf{P} \mathbf{B} \mathbf{B}^T \mathbf{P} = 0$	Dissipation inequality: $\mathbf{A}^T \mathbf{P} + \mathbf{P} \mathbf{A} + \mathbf{C}^T \mathbf{C} \geq 0$

Table II. The order of the various  $\mathcal{H}_\infty$ /LTR controllers

Design problem	$\ \mathbf{H}(\cdot)\ _\infty < \gamma$	Controller type	Min. phase	Non-min. phase
Problem # 1	$\mathbf{H}(s) = \mathbf{M}_I(s)$	Full order obs.	$n$ th order	$n$ th order
Problem # 2	$\mathbf{H}(s) = \mathbf{E}_S(s)$	Q-obs. based	$n$ th order	$2n$ th order
Problem # 3	$\mathbf{H}(s) = \mathbf{E}_S(s)$	General	$n$ th order	$2n$ th order
Problem # 4	$\mathbf{H}(s) = \mathbf{E}_{IO}(s)$	Q-obs. based	$n$ th order	$2n$ th order
Problem # 5	$\mathbf{H}(s) = \mathbf{E}_{IO}(s)$	General	$n$ th order	$2n$ th order

where the 'inf' is taken over all internally stabilizing FDLTI controllers of order no greater than  $2n$ . Correspondingly, we define:

$$\gamma_n^* = \inf_{\mathcal{C}_n} \|E_S\|_\infty \quad (100)$$

where the 'inf' is taken over all internally stabilizing FDLTI controllers of order no greater than  $n$ .

Clearly  $\gamma_{2n}^* \leq \gamma_n^*$ . Only in the special case, where  $\gamma_{2n}^* = \gamma_n^*$ , we are guaranteed that an  $n$ th-order standard observer based controller will suffice. Otherwise controllers of order higher than  $n$  are required for near-optimal performance, in general.

In the special cases of a symptotic recovery, i.e.  $\gamma_{2n}^* = 0$ , it can be shown that  $\gamma_n^* = \gamma_{2n}^* = 0$ . Necessary and sufficient conditions for obtaining asymptotic recovery are given in [14].

In Reference 12 the sensitivity recovery case has also been treated as an  $\mathcal{H}_\infty$  problem. The approach in Reference 12 is based on frequency-domain methods, using coprime factorizations of the systems, and the solutions are found using the regular  $\mathcal{H}_\infty$  theory. However, to make the  $\mathcal{H}_\infty$  problem regular, it has been necessary to consider plants including direct terms, i.e. plants given by:

$$\mathbf{G}(s) = \mathbf{C}(s\mathbf{I} - \mathbf{A})^{-1}\mathbf{B} + \mathbf{D} \quad (101)$$

where  $\mathbf{D}$  has full column rank. When  $\mathbf{D}$  does not have full column rank, only approximative solutions are given, whereas our results give exact answers. Further, the controller order in Reference 12 is  $3n - 1$  if no model reduction is carried out, whereas the order for the state-space approach based controllers introduced in this paper never exceed  $2n$ . In the minimum phase case, our controllers are of order  $n$ , where the controllers in Reference 12 are of order  $3n - 1$  for non-square systems.

In the rest of this section, we will demonstrate how the presented  $\mathcal{H}_\infty$ /LTR design very easily can be extended to include non-strictly proper plants as given by (101), except that  $\mathbf{D}$  is not required to have full column rank. In this case it is easily seen that the recovery matrix is:

$$\mathbf{M}_1(s) = \mathbf{F}(s\mathbf{I} - \mathbf{A} - \mathbf{K}\mathbf{C})^{-1}(\mathbf{B} + \mathbf{K}\mathbf{D}) + \mathbf{Q}(s)\mathbf{C}(s\mathbf{I} - \mathbf{A} - \mathbf{K}\mathbf{C})^{-1}(\mathbf{B} + \mathbf{K}\mathbf{D}) \quad (102)$$

for non-strictly proper plants, when the Q-observer is used,  $\mathbf{Q} \in \mathcal{RH}_\infty$ . The recovery error is then given by the following lemma.

#### Lemma 5.1

Let the errors  $\mathbf{E}_S(s)$  and  $\mathbf{E}_{IO}(s)$  be as in Definition 2.1, and the recovery matrix  $\mathbf{M}_1(s)$  as in (102). Then we get:

$$\begin{aligned} \mathbf{E}_S(s) = & (\mathbf{I} + \mathbf{F}(s\mathbf{I} - \mathbf{A} - \mathbf{B}\mathbf{F})^{-1}\mathbf{B})(\mathbf{F}(s\mathbf{I} - \mathbf{A} - \mathbf{K}\mathbf{C})^{-1}(\mathbf{B} + \mathbf{K}\mathbf{D}) \\ & + \mathbf{Q}(s)\mathbf{C}(s\mathbf{I} - \mathbf{A} - \mathbf{K}\mathbf{C})^{-1}(\mathbf{B} + \mathbf{K}\mathbf{D})) \end{aligned} \quad (103)$$

$$\begin{aligned} \mathbf{E}_{IO}(s) = & (\mathbf{C} + \mathbf{D}\mathbf{F})(s\mathbf{I} - \mathbf{A} - \mathbf{B}\mathbf{F})^{-1}\mathbf{B}(\mathbf{F}(s\mathbf{I} - \mathbf{A} - \mathbf{K}\mathbf{C})^{-1}(\mathbf{B} + \mathbf{K}\mathbf{D}) \\ & + \mathbf{Q}(s)\mathbf{C}(s\mathbf{I} - \mathbf{A} - \mathbf{K}\mathbf{C})^{-1}(\mathbf{B} + \mathbf{K}\mathbf{D})) \end{aligned} \quad (104)$$

where  $\mathbf{Q} \in \mathcal{RH}_\infty$ .

Solutions to the two more general problems associated with these expressions for  $\mathbf{E}_S(s)$  and  $\mathbf{E}_{IO}(s)$  can be obtained by straightforward extensions of the results in this paper. Note, that only the dual quadratic matrix inequality are modified. Instead of being totally singular they will be neither regular nor totally singular. For reasons of brevity, we shall not pursue this subject further here.

The standard  $\mathcal{H}_\infty$  setup can equivalently be extended to handle non-strictly proper plants.

## 6. A NON-MINIMUM PHASE EXAMPLE

In this section we shall study an example of a non-minimum phase system to which the various controllers of this paper will be applied. We shall give comparisons of the recovery achieved by LQG/LTR controllers and  $\mathcal{H}_\infty$ /LTR controllers designed by the four different techniques described in this paper. We shall consider design based on both types of recovery errors, which will also be compared to the  $\mathcal{H}_\infty$ /LTR design which results from considering the recovery matrix, a design method which has been treated in References [21, 23]. At this point, we would like to stress that the controller designs carried out in this section only aim to make the  $\mathcal{H}_\infty$  norm for the specified problem 'very small'. Hence, we shall in all cases design controllers having closed loop performance very close to the infimally achievable  $\mathcal{H}_\infty$  norm  $\gamma^*$ . This will in general have some drawbacks in terms of bandwidth etc., and in practice one wouldn't normally design controllers with  $\gamma \approx \gamma^*$ . The example is, however, merely meant to illustrate the theoretical results and design methods outlined in this paper.  $\gamma^*$  is determined in the sequel by an iteration technique.

### 6.1. The recovery matrix

We shall consider the system given by the following state-space matrices:

$$\mathbf{A} = \begin{bmatrix} -5.5000 & -0.6325 \\ 0.6325 & 0.0000 \end{bmatrix}, \quad \mathbf{B} = \begin{bmatrix} 1.0000 \\ 0.0000 \end{bmatrix}, \quad \mathbf{C} = [1.0000 \quad -1.5811]$$

This system has a right half plane zero,  $z = 1.000$ .

As the target state feedback let us take:

$$\mathbf{F} = [1.0000 \quad -8.9525]$$

A standard LQG/LTR calculation gives the following observer gain:

$$\mathbf{K} = \begin{bmatrix} -22453 \\ 5797 \end{bmatrix}$$

Applying the LQG/LTR controller the maximal singular value of  $\mathbf{M}_I(s)$  becomes  $1.35 \sim 2.62$  dB. For the  $\mathcal{H}_\infty$  problem described in References [21, 23], the infimally achievable  $\mathcal{H}_\infty$  norm is  $\gamma^* = 0.67 \sim -3.36$  dB, and we can hence improve the LQG/LTR design by 6 dB by the technique described in References [21, 23]. As a bound for the  $\mathcal{H}_\infty$  problem we have to select  $\gamma > \gamma^*$  so we choose, for example,  $\gamma = 0.68 \sim -3.35$  dB.

By the technique outlined in References [21, 23], we find:

$$\mathbf{K} = \begin{bmatrix} 11100 \\ 7337 \end{bmatrix}$$

to satisfy the  $\mathcal{H}_\infty$  bound.

The recovery matrices achieved by applying these two second-order controllers are shown in Figure 5. The  $\mathcal{H}_\infty$  plot has a maximum peak which is 6 dB lower than the maximum peak of the LQG plot. However, because of the restricted freedom of a second-order controller this gain in recovery level is paid for by a higher roll-off frequency.

### 6.2. The sensitivity recovery error

With the above system, we consider the problem of minimizing the sensitivity recovery error by means of a Q-observer based controller as described in Section 3. For this problem, the

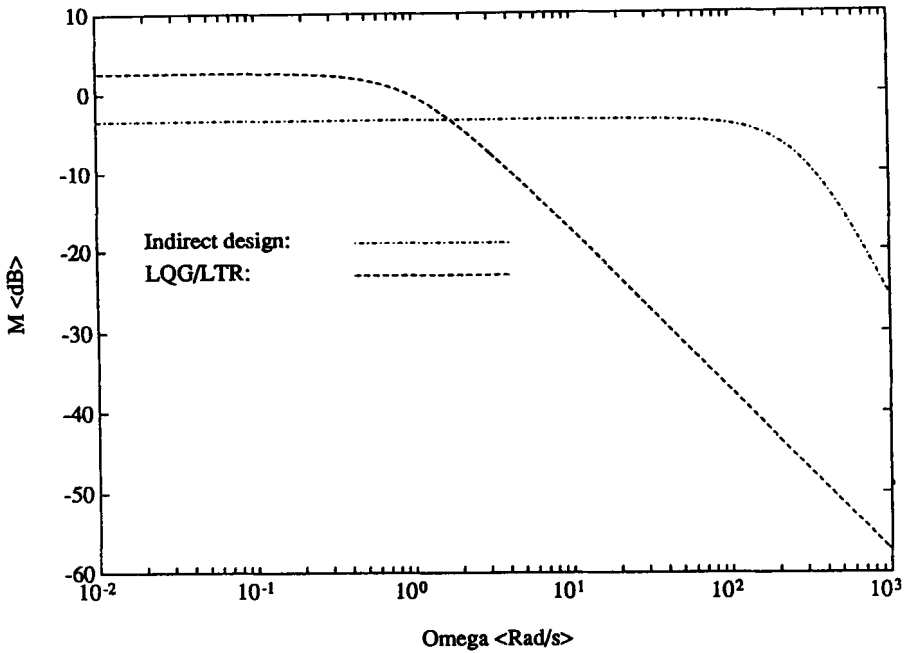

Figure 5. The recovery matrix

infimally achievable  $\mathcal{H}_\infty$  norm turns out to be  $\gamma^* = 0.40 \sim -7.75$  dB so let us choose  $\gamma = 0.41 \sim -7.74$  dB as a specification level of sensitivity recovery.

According to Theorem 3.1, the solution to the quadratic matrix inequality is  $\bar{\mathbf{P}} = \mathbf{0}$ , since  $\mathbf{A}$  is stable.

The dual quadratic matrix inequality is solved using the algorithm in Appendix B giving:

$$\bar{\mathbf{Q}} = \begin{bmatrix} 1.2815 & 0.8105 & -0.5167 & -0.3268 \\ 0.8105 & 0.5126 & -0.3268 & -0.2067 \\ -0.5167 & -0.3268 & 0.2084 & 0.1318 \\ -0.3268 & -0.2067 & 0.1318 & 0.0833 \end{bmatrix}$$

The condition (A.19) is satisfied for:

$$\mathbf{L} = -\bar{\mathbf{C}}_{2,P} = -[\mathbf{F} \ \mathbf{F}] = [-1.0000 \quad 8.9525 \quad -1.0000 \quad 8.9525]$$

Now, defining:

$$\bar{\mathbf{A}}_{P,Q} = \bar{\mathbf{A}} + \gamma^{-2} \bar{\mathbf{Q}} \bar{\mathbf{C}}_2^T \bar{\mathbf{C}}_2$$

we obtain a minimum phase system  $(\bar{\mathbf{A}}_{P,Q}^T, \bar{\mathbf{C}}_1^T, \bar{\mathbf{E}}^T, \mathbf{0})$ . Consequently, we can determine  $\mathbf{M}$  such that:

$$\|\bar{\mathbf{E}}^T (s\mathbf{I} - \bar{\mathbf{A}}_{P,Q}^T - \bar{\mathbf{C}}_1^T \mathbf{M}^T)^{-1}\|_\infty < \gamma / \|\bar{\mathbf{C}}_2\|$$

This is for instance achieved by:

$$\mathbf{M} = \begin{bmatrix} 8337 \\ 5941 \\ -3789 \\ -2396 \end{bmatrix}$$

and the controller becomes:

$$\mathbf{Q}(s) = \bar{\mathbf{C}}_2(s\mathbf{I} - \bar{\mathbf{A}} + \bar{\mathbf{B}}\bar{\mathbf{C}}_2 - \mathbf{M}\bar{\mathbf{C}}_1)^{-1}\mathbf{M}$$

Now, let us consider the solution to the same problem in the standard formulation in Section 3.3. Of course the infimally achievable  $\mathcal{H}_\infty$  norm is the same in either formulation so we choose the same  $\gamma$  as above as our specification.

Since  $\mathbf{A}$  is stable, according to Theorem 3.7,  $\bar{\mathbf{P}} = \mathbf{0}$  is the unique solution to the quadratic matrix inequality. For the dual quadratic matrix inequality we apply Algorithm B.1 to obtain:

$$\bar{\mathbf{Q}} = \begin{bmatrix} 1.2815 & 0.8105 & 0.7648 & 0.4837 \\ 0.8105 & 0.5126 & 0.4837 & 0.3059 \\ 0.7648 & 0.4837 & 0.4564 & 0.2887 \\ 0.4837 & 0.3059 & 0.2887 & 0.1826 \end{bmatrix}$$

From (72) we obtain:

$$\mathbf{L} = [\mathbf{0} \ \mathbf{F}] = [0.0000 \quad 0.0000 \quad 1.0000 \quad -8.9525]$$

Calculating:

$$\bar{\mathbf{A}}_{\mathbf{P},\mathbf{Q}} = \bar{\mathbf{A}} + \gamma^{-2}\bar{\mathbf{Q}}\bar{\mathbf{C}}_2^T\bar{\mathbf{C}}_2$$

we are able to determine  $\mathbf{M}$  such that:

$$\|\bar{\mathbf{E}}^T(s\mathbf{I} - \bar{\mathbf{A}}_{\mathbf{P},\mathbf{Q}} - \bar{\mathbf{C}}_1^T\mathbf{M}^T)^{-1}\|_\infty < \gamma / \|\bar{\mathbf{C}}_2\|$$

Since an almost disturbance decoupling problem is solvable for the transformed system. One possible choice is:

$$\mathbf{M} = \begin{bmatrix} -1464 \\ -1050 \\ -796 \\ -627 \end{bmatrix}$$

The resulting controller is:

$$\mathbf{Q}(s) = -\bar{\mathbf{C}}_2(s\mathbf{I} - \bar{\mathbf{A}} - \bar{\mathbf{B}}\bar{\mathbf{C}}_2 - \mathbf{M}\bar{\mathbf{C}}_1)^{-1}\mathbf{M}$$

Figure 6 shows the sensitivity recovery errors achieved by applying these two fourth-order controllers compared to the two second-order controllers given above.

The two fourth-order controllers both have max peaks close to  $\gamma$  which is an improvement of 6 dB and 7 dB compared to the LQG controller and the ' $\mathbf{M}_I$  minimizing' controller, respectively. Note that the discrepancies in achieved  $\mathcal{H}_\infty$  norm is not due to the different controller orders, but simply illustrates the fact that, when design is based on an  $\mathcal{H}_\infty$  bound for  $\mathbf{M}_I$ , we are not guaranteed anything about the  $\mathcal{H}_\infty$  norm of  $\mathbf{E}_S$ .

### 6.3. The input-output recovery error

For the  $\mathcal{H}_\infty$  problem described by (78) the corresponding fourth-order quadratic matrix inequality can by Theorem 4.1 be reduced to a second-order dissipation inequality, which in Algorithm B.1 reduces to a scalar quadratic equation.  $\gamma^*$  equals  $0.11 \sim -18.6$  dB. Let us

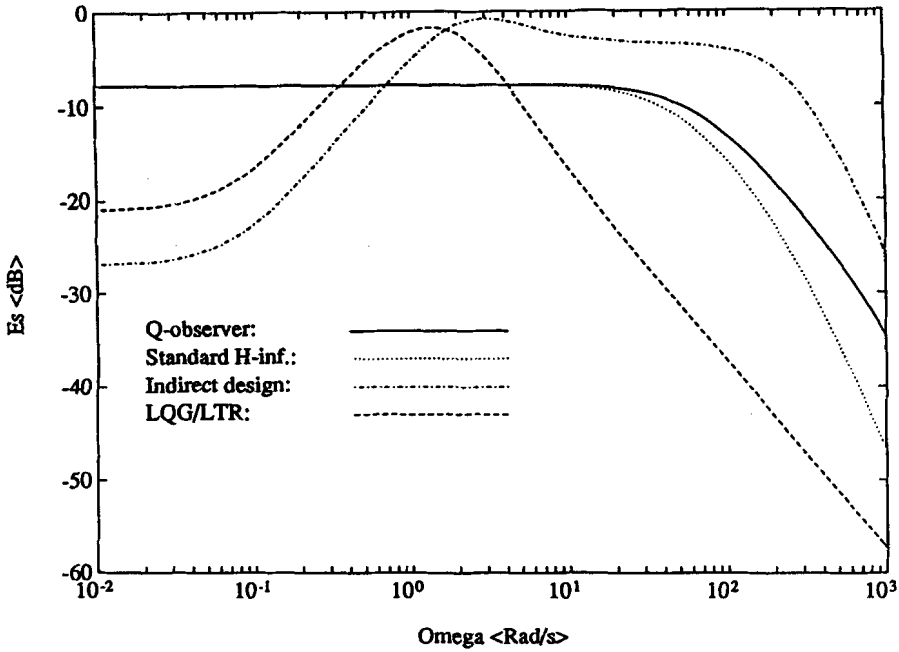

Figure 6. The sensitivity recovery error

choose  $\gamma = 0.12 \sim -18.4$  dB. We get:

$$\bar{P} = \begin{bmatrix} 0 & 0 & 0 & 0 \\ 0 & 0 & 0 & 0 \\ 0 & 0 & 0 & 0 \\ 0 & 0 & 0 & 4.9995 \end{bmatrix}$$

The dual quadratic matrix inequality is solved by Algorithm B.1 and yields:

$$\bar{Q} = \begin{bmatrix} 0.8172 & 0.5169 & -0.3295 & -0.2084 \\ 0.5169 & 0.3269 & -0.2084 & -0.1318 \\ -0.3295 & -0.2084 & 0.1329 & 0.0840 \\ -0.2084 & -0.1318 & 0.0840 & 0.0532 \end{bmatrix}$$

We perform the transformations and obtain the following solutions to the almost disturbance decoupling problem and the almost disturbance decoupled estimation problem,

$$L = [-1.0000 \quad 8.9525 \quad -383.4 \quad -602.2] \text{ resp. } M = \begin{bmatrix} 3658 \\ 2809 \\ -1793 \\ -1133 \end{bmatrix}$$

Note that  $L = [-F \quad L_2]$  as stated in Lemma 4.5.

For the general controller structure of Section 4.2, the  $\mathcal{H}_\infty$  problem associated with  $E_{IO}$ , the

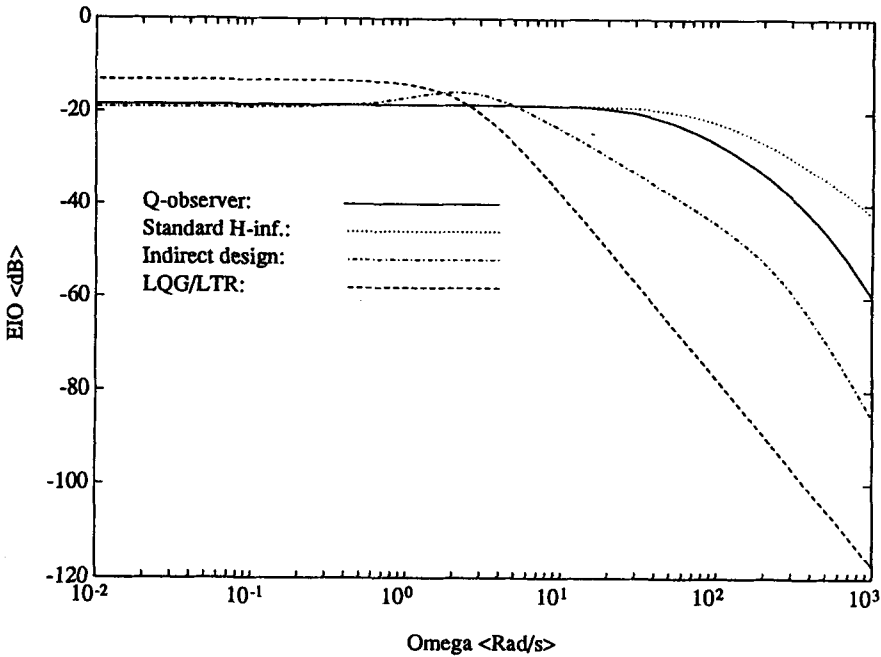

Figure 7. The input-output recovery error

quadratic matrix inequality has the following solution:

$$\bar{\mathbf{P}} = \begin{bmatrix} \mathbf{P} & -\mathbf{P} \\ -\mathbf{P} & \mathbf{P} \end{bmatrix} = \begin{bmatrix} 0 & 0 & 0 & 0 \\ 0 & 4.9995 & 0 & -4.9995 \\ 0 & 0 & 0 & 0 \\ 0 & -4.9995 & 0 & 4.9995 \end{bmatrix}$$

which is effectively obtained by solving a scalar quadratic equation, when Theorem 4.7 is applied. The dual quadratic matrix inequality has the following solution:

$$\bar{\mathbf{Q}} = \begin{bmatrix} 0.0420 & 0.0266 & 0.0251 & 0.0159 \\ 0.0266 & 0.0168 & 0.0159 & 0.0100 \\ 0.0251 & 0.0159 & 0.0150 & 0.0095 \\ 0.0159 & 0.0100 & 0.0095 & 0.0060 \end{bmatrix}$$

We perform the transformation, and achieve the following two gain matrices associated with the controller given by Lemma 4.9:

$$\mathbf{L} = [-1276 \quad -2024 \quad 1277 \quad 2015] \text{ and } \mathbf{M} = \begin{bmatrix} 39 & 142 \\ 27 & 018 \\ 21 & 916 \\ 16 & 123 \end{bmatrix}$$

The input-output recovery achieved by these two fourth-order controllers is displayed in Figure 7. Also the recovery of the two second-order controllers of Section 6.1 is shown. This time the fourth-order controllers have an  $\mathcal{H}_\infty$  norm which is 2.7 dB better than the  $\mathcal{H}_\infty$  second-order controller and 5.4 dB better than the LQG controller. Again, the improvement is not



due to the extra dynamics but is explained by the fact, that the fourth-order controllers aimed directly at a good input–output recovery.

#### 6.4. Conclusions concerning the example

As our main conclusion, let us emphasize that a compensator solving a control problem, performs in accordance with the specifications for which the problem was posed, and the behaviour concerning different specifications might be arbitrarily bad in general. Hence, if we wish a closed loop system to have good sensitivity recovery, for example, the control problem should be stated as a sensitivity recovery problem, since a recovery matrix reduction does not yield any specific guarantees for the sensitivity recovery in the non-minimum phase case.

In the example, a controller which ‘minimizes’ the  $\mathcal{H}_\infty$  norm of  $\mathbf{M}_I(s)$  gives a better input–output recovery than the LQG controller, but a (slightly) worse sensitivity recovery. Both controllers, though, behave considerably worse than the dedicated  $\mathcal{H}_\infty$  controllers in both cases.

Another matter is the question of controller order. In the authors’ opinion the best way to achieve an  $n$ th-order controller, in the case where no specific simplifying conditions such as described in Sections 3 and 4 exist, is to design a  $2n$ th-order dedicated controller and then perform frequency-weighted model reduction. It should be noted, however, that the best approach to this, is to start with a  $\gamma$  which is not too close to  $\gamma^*$ . Otherwise, the states of the  $2n$ th-order controller all tend to get ‘important’, as computing experience with the above example has shown.

## 7. CONCLUSIONS

In this paper we have given a precise formulation of the  $\mathcal{H}_\infty$ /LTR problem based on the sensitivity recovery error and the input–output recovery error, where the  $\mathcal{H}_\infty$  constraint has been imposed directly on these recovery errors.

The  $\mathcal{H}_\infty$ /LTR problem has been treated in two ways: (1) in a straightforward fashion allowing for a general controller structure, and (2) with the constraint that the controller should be a Q-observer based controller as described in Reference 2. The Q-observer structure allows the  $\mathcal{H}_\infty$  contribution to the controller to be appended (in a block-diagram sense) to a standard full-order observer based controller, which is appealing from a practical point of view.

The four resulting controllers are given in terms of the unique solution to the dual quadratic matrix inequality of order  $2n$ , and additionally by the solution to an  $n$ th-order (singular) matrix Riccati equation (the two sensitivity cases) or, respectively, a  $n$ th-order dissipation inequality (the input–output cases). By the algorithms in Appendix B, the quadratic matrix inequality is in turn reduced to a reduced order matrix Riccati equation. Let us emphasize that all results in this paper are completely constructive, and controllers can be found using well-known computational techniques.

Comparing the  $\mathcal{H}_\infty$ /LTR design methods proposed above to traditional LTR methods, a major advantage is that non-minimum phase systems can be treated by exactly the same techniques as minimum phase systems after a preliminary transformation has been performed. This preliminary transformation involves a state-space transformation and the solution to a reduced order Riccati equation. The preliminary transformation is a one-shot process requiring no iterations.

The four controllers considered in this paper are all of dynamic order at most  $2n$  in the non-minimum phase case. For the controllers, though, a reduction can be carried out if the system

considered fulfils a minimum phase condition (although the reduction is possible also for certain non-minimum phase systems) yielding an  $n$ th-order standard full-order observer based controller structure.

As it has been mentioned in Section 6,  $n$ th-order controllers can also be achieved by doing frequency-weighted model order reduction (which should probably emphasize cross-over frequencies). But, if model order reduction is intended from the start, the recovery specification level  $\gamma$  should not be chosen too close to the infimally achievable value  $\gamma^*$ , since this tends to make the condition numbers of the gramians small, i.e. the smallest singular values become important to the design as well as the larger ones.

Not surprisingly the LQG controller does not compete with the  $\mathcal{H}_\infty$  controllers in the example of Section 6, when the maximal singular values are considered. This is rather obvious, owing to the fact that when a controller is designed with a certain optimality criterion it will behave optimal with respect to *that* criterion, and arbitrarily bad for other criteria. There are, though, some good reasons for applying the  $\mathcal{H}_\infty$  norm as opposed to other norms to LTR problems, since LTR typically is the last step in an overall design procedure, where the first step is robustness loop shaping. But to design for robustness the design objective must be posed in the  $\mathcal{H}_\infty$  norm.

On closing, it is important to note some of the limitations of an automatic design procedure such as the one described in this paper. First of all, we have not been dealing with the first part of the design procedure, the state feedback design. For uncertain systems one should pay attention to the fact that not all robustness properties are guaranteed simply by the use of state feedbacks. State feedbacks themselves have to be designed such that the knowledge of the uncertainty structure is exploited. Then in our approach robust stability with respect to unmodelled dynamics is preserved in the dynamic output feedback controller implementation. Other kinds of uncertainties have to be taken care of separately. Finally, in this paper we have studied the  $\mathcal{H}_\infty$  norm of two recovery errors. In some practical applications, the given control objective is instead to reduce the norm of the recovery errors in certain frequency windows only. Hence, it would be relevant to incorporate weighting functions for the recovery errors in the theory. This can be done of course. However, the price is twofold. First, the order of the controllers will be even higher than  $2n$ . Second, part of the structure of the solutions will vanish, implying that the algorithms will be slightly further complicated. Thus, a subject for further research is to consider weighed recovery errors by lower-order controllers.

## APPENDIX A

The required preliminaries for the  $\mathcal{H}_\infty$  method used in this paper will be introduced in this appendix. The approach taken is based on the results in Reference 20, the so-called singular  $\mathcal{H}_\infty$  approach. This is a very general approach which includes the well-known approach by Doyle *et al.*<sup>3</sup> as a special case.

In the state-space approach to  $\mathcal{H}_\infty$  the standard problem is as follows. Consider a finite-dimensional, linear, time-invariant system:

$$\Sigma: \begin{cases} \dot{\mathbf{x}} = \mathbf{A}\mathbf{x} + \mathbf{B}\mathbf{u} + \mathbf{E}\mathbf{w} & \mathbf{x} \in \mathbb{R}^n, \mathbf{u} \in \mathbb{R}^m, \mathbf{w} \in \mathbb{R}^q \\ \mathbf{y} = \mathbf{C}_1\mathbf{x} + \mathbf{D}_1\mathbf{w} & \mathbf{y} \in \mathbb{R}^p \\ \mathbf{z} = \mathbf{C}_2\mathbf{x} + \mathbf{D}_2\mathbf{u} & \mathbf{z} \in \mathbb{R}^r \end{cases} \quad (\text{A.1})$$

We assume that  $\gamma > 0$  has been given. We wish to design, if possible, an internally stabilizing FDLTI compensator  $\mathbf{u} = \mathbf{Q}(s)\mathbf{y}$  such that the  $\mathcal{H}_\infty$  norm of the resulting closed loop transfer function from  $\mathbf{w}$  to  $\mathbf{z}$  is smaller than  $\gamma$ .

### Assumption A.1

It is assumed that the systems  $(\mathbf{A}, \mathbf{B}, \mathbf{C}_2, \mathbf{D}_2)$  and  $(\mathbf{A}, \mathbf{E}, \mathbf{C}_1, \mathbf{D}_1)$  have no invariant zeros in  $\mathbb{C}^0$ .

The main result is:

*Theorem A.2*

Consider the system  $\Sigma$  above satisfying Assumption A.1. Let  $\gamma > 0$  be given. Then, there exists a FDLTI compensator  $\mathbf{u} = \mathbf{Q}(s)\mathbf{y}$  for which the  $\mathcal{H}_\infty$  norm of the resulting closed-loop transfer function from  $\mathbf{w}$  to  $\mathbf{z}$  is smaller than  $\gamma$ , if and only if there exist  $\mathbf{P} \geq 0$  and  $\mathbf{Q} \geq 0$  for which:

- (1)  $\mathbf{F}_\gamma(\mathbf{P}) \geq 0$
- (2)  $\mathbf{G}_\gamma(\mathbf{Q}) \geq 0$
- (3)  $\text{rank } \mathbf{F}_\gamma(\mathbf{P}) = \text{normrank } \mathbf{G}$
- (4)  $\text{rank } \mathbf{G}_\gamma(\mathbf{Q}) = \text{normrank } \mathbf{H}$
- (5)  $\text{rank} \begin{bmatrix} \mathbf{L}_\gamma(\mathbf{P}, s) \\ \mathbf{F}_\gamma(\mathbf{P}) \end{bmatrix} = n + \text{normrank } \mathbf{G}, \forall s \in \mathbb{C}^+ \cup \mathbb{C}^0$
- (6)  $\text{rank} [\mathbf{M}_\gamma(\mathbf{Q}, s) \ \mathbf{G}_\gamma(\mathbf{Q})] = n + \text{normrank } \mathbf{H}, \forall s \in \mathbb{C}^+ \cup \mathbb{C}^0$
- (7)  $\rho(\mathbf{P}\mathbf{Q}) < \gamma^2$

where the notation used is as follows:

$$\mathbf{F}_\gamma(\mathbf{P}) = \begin{bmatrix} \mathbf{A}^T\mathbf{P} + \mathbf{P}\mathbf{A} + \mathbf{C}_2^T\mathbf{C}_2 + \gamma^{-2}\mathbf{P}\mathbf{E}\mathbf{E}^T\mathbf{P} & \mathbf{P}\mathbf{B} + \mathbf{C}_2^T\mathbf{D}_2 \\ \mathbf{B}^T\mathbf{P} + \mathbf{D}_2^T\mathbf{C}_2 & \mathbf{D}_2^T\mathbf{D}_2 \end{bmatrix} \quad (\text{A.2})$$

$$\mathbf{G}_\gamma(\mathbf{Q}) = \begin{bmatrix} \mathbf{A}\mathbf{Q} + \mathbf{Q}\mathbf{A}^T + \mathbf{E}\mathbf{E}^T + \gamma^{-2}\mathbf{Q}\mathbf{C}_2^T\mathbf{C}_2\mathbf{Q} & \mathbf{Q}\mathbf{C}_1^T + \mathbf{E}\mathbf{D}_1^T \\ \mathbf{C}_1\mathbf{Q} + \mathbf{D}_1\mathbf{E}^T & \mathbf{D}_1\mathbf{D}_1^T \end{bmatrix} \quad (\text{A.3})$$

$$\mathbf{L}_\gamma(\mathbf{P}, s) = [s\mathbf{I} - \mathbf{A} - \gamma^{-2}\mathbf{E}\mathbf{E}^T\mathbf{P} - \mathbf{B}], \quad \mathbf{M}_\gamma(\mathbf{Q}, s) = \begin{bmatrix} s\mathbf{I} - \mathbf{A} - \gamma^{-2}\mathbf{Q}\mathbf{C}_2^T\mathbf{C}_2 \\ -\mathbf{C}_1 \end{bmatrix} \quad (\text{A.4})$$

$$\mathbf{G}(s) = \mathbf{C}_2(s\mathbf{I} - \mathbf{A})^{-1}\mathbf{B} + \mathbf{D}_2, \quad \mathbf{H}(s) = \mathbf{C}_1(s\mathbf{I} - \mathbf{A})^{-1}\mathbf{E} + \mathbf{D}_1 \quad (\text{A.5})$$

The proof of Theorem A.2 can be found in Reference 20. We shall refer to condition (1) as the *quadratic matrix inequality*, and any  $\mathbf{P} \geq 0$  satisfying (1) will be called a solution to the quadratic matrix inequality. Analogously we shall call (2) the *dual quadratic matrix inequality*, and refer to as solutions to the dual quadratic matrix inequality any  $\mathbf{Q} \geq 0$  satisfying (2). Conditions (3) and (5) guarantees that a solution to the quadratic matrix inequality is unique and of minimal rank (and dually for the dual quadratic matrix inequality with (4) and (6)). (7) is a typical  $\mathcal{H}_\infty$  coupling condition, which also appears in Reference 3.

Further, we shall need a couple of corollaries.

*Corollary A.3. The regular case*

Assume that  $\mathbf{D}_2$  is injective. Then (1), (3) and (5) are satisfied if and only if

$$\mathbf{A}^T\mathbf{P} + \mathbf{P}\mathbf{A} + \mathbf{C}_2^T\mathbf{C}_2 + \gamma^{-2}\mathbf{P}\mathbf{E}\mathbf{E}^T\mathbf{P} - (\mathbf{P}\mathbf{B} + \mathbf{C}_2^T\mathbf{D}_2)(\mathbf{D}_2^T\mathbf{D}_2)^{-1}(\mathbf{B}^T\mathbf{P} + \mathbf{D}_2^T\mathbf{C}_2) = 0$$

and

$$\Lambda(\mathbf{A} + \gamma^{-2}\mathbf{E}\mathbf{E}^T\mathbf{P} - \mathbf{B}(\mathbf{D}_2^T\mathbf{D}_2)^{-1}(\mathbf{B}^T\mathbf{P} + \mathbf{D}_2^T\mathbf{C}_2)) \subset \mathbb{C}^-$$

*Corollary A.4. The totally singular case*

Assume  $\mathbf{D}_2 = 0$ . Then (1) is equivalent to:

$$\mathbf{A}^T\mathbf{P} + \mathbf{P}\mathbf{A} + \mathbf{C}_2^T\mathbf{C}_2 + \gamma^{-2}\mathbf{P}\mathbf{E}\mathbf{E}^T\mathbf{P} \geq 0$$

where  $\mathbf{P}$  satisfies  $\mathbf{P}\mathbf{B} = 0$ .

The two corollaries have straightforward duals, which are also used in this paper.

Expressions for admissible controllers will be given in the following in terms of the matrices for certain transformations of  $\Sigma$ . First we defined  $\mathbf{C}_{2,\mathbf{P}}$  and  $\mathbf{D}_\mathbf{P}$  by the following factorization:

$$\mathbf{F}_\gamma(\mathbf{P}) = [\mathbf{C}_{2,\mathbf{P}} \ \mathbf{D}_\mathbf{P}]^T \times [\mathbf{C}_{2,\mathbf{P}} \ \mathbf{D}_\mathbf{P}] \quad (\text{A.6})$$

Moreover, we will need the following matrices:

$$\mathbf{A}_P = \mathbf{A} + \gamma^{-2} \mathbf{E} \mathbf{E}^T \mathbf{P}, \quad \mathbf{C}_{1,P} = \mathbf{C}_1 + \gamma^{-2} \mathbf{D}_1 \mathbf{E}^T \mathbf{P} \quad (\text{A.7})$$

$$\mathbf{Y} = (\mathbf{I} - \gamma^{-2} \mathbf{Q} \mathbf{P})^{-1} \mathbf{Q} \quad (\text{A.8})$$

$$\mathbf{A}_{P,Q} = \mathbf{A}_P + \gamma^{-2} \mathbf{Y} \mathbf{C}_{2,P}^T \mathbf{C}_{2,P}, \quad \mathbf{B}_{P,Q} = \mathbf{B} + \gamma^{-2} \mathbf{Y} \mathbf{C}_{2,P}^T \mathbf{D}_P \quad (\text{A.9})$$

We shall refer to the system where  $\mathbf{A}_P$ ,  $\mathbf{C}_{1,P}$ ,  $\mathbf{C}_{2,P}$  and  $\mathbf{D}_P$  substitute  $\mathbf{A}$ ,  $\mathbf{C}_1$ ,  $\mathbf{C}_2$  and  $\mathbf{D}_2$  as the *full information transformation* of the system  $\Sigma$ . The dual quadratic matrix inequality for the system obtained by the full information transformation becomes:

$$\tilde{G}_\gamma(\mathbf{Y}) = \begin{bmatrix} \mathbf{A}_P \mathbf{Y} + \mathbf{Y} \mathbf{A}_P^T + \mathbf{E} \mathbf{E}^T + \gamma^{-2} \mathbf{Y} \mathbf{C}_{2,P}^T \mathbf{C}_{2,P} \mathbf{Y} & \mathbf{Y} \mathbf{C}_{1,P}^T + \mathbf{E} \mathbf{D}_1^T \\ \mathbf{C}_{1,P} \mathbf{Y} + \mathbf{D}_1 \mathbf{E}^T & \mathbf{D}_1 \mathbf{D}_1^T \end{bmatrix} = [\mathbf{E}_{P,Q}^T \ \mathbf{D}_{P,Q}^T]^T \times [\mathbf{E}_{P,Q}^T \ \mathbf{D}_{P,Q}^T] \geq 0 \quad (\text{A.10})$$

Substituting  $\mathbf{A}_{P,Q}$ ,  $\mathbf{B}_{P,Q}$ ,  $\mathbf{E}_{P,Q}$  and  $\mathbf{D}_{P,Q}$  for the corresponding variables in the previous system will be referred to as the *full control transformation*. The system obtained by the full control transformation becomes:

$$\Sigma_{P,Q}: \begin{cases} \dot{\mathbf{x}} = \mathbf{A}_{P,Q} \mathbf{x} + \mathbf{B}_{P,Q} \mathbf{u} + \mathbf{E}_{P,Q} \mathbf{w} \\ \mathbf{y} = \mathbf{C}_{1,P} \mathbf{x} + \mathbf{D}_{P,Q} \mathbf{w} \\ \mathbf{z} = \mathbf{C}_{2,P} \mathbf{x} + \mathbf{D}_P \mathbf{u} \end{cases} \quad (\text{A.11})$$

In terms of these transformed system matrices we can compute the desired  $\mathcal{H}_\infty$  controller:

*Theorem A.5*

Let  $\mathbf{A}_{P,Q}$ ,  $\mathbf{B}_{P,Q}$  and  $\mathbf{C}_{1,P}$  be as above. Let  $\mathbf{L}$  be a state feedback, such that  $\mathbf{A}_{P,Q} + \mathbf{B}_{P,Q} \mathbf{L}$  is stable, and such that:

$$\| (\mathbf{C}_{2,P} + \mathbf{D}_P \mathbf{L}) (\mathbf{sI} - \mathbf{A}_{P,Q} - \mathbf{B}_{P,Q} \mathbf{L})^{-1} \|_\infty < \gamma / (3 \cdot \| \mathbf{E}_{P,Q} \|) \quad (\text{A.12})$$

Let  $\mathbf{M}$  be an output injection, such that  $\mathbf{A}_{P,Q} + \mathbf{M} \mathbf{C}_{1,P}$  is stable and further:

$$\| (\mathbf{sI} - \mathbf{A}_{P,Q} - \mathbf{M} \mathbf{C}_{1,P})^{-1} (\mathbf{E}_{P,Q} + \mathbf{M} \mathbf{D}_{P,Q}) \|_\infty < \tilde{\gamma} \quad (\text{A.13})$$

where

$$\tilde{\gamma} = \min \{ \gamma / (3 \cdot \| \mathbf{D}_P \mathbf{L} \|), \| \mathbf{E}_{P,Q} \| / \| \mathbf{B}_{P,Q} \mathbf{L} \| \}$$

Then the controller:

$$\mathbf{u} = -\mathbf{L} (\mathbf{sI} - \mathbf{A}_{P,Q} - \mathbf{B}_{P,Q} \mathbf{L} - \mathbf{M} \mathbf{C}_{1,P})^{-1} \mathbf{M} \mathbf{y} \quad (\text{A.14})$$

makes the  $\mathcal{H}_\infty$  norm of the resulting closed loop transform function from  $\mathbf{w}$  to  $\mathbf{z}$  in  $\Sigma$  smaller than  $\gamma$ .

The significance of Theorem A.5 is to transform the original  $\mathcal{H}_\infty$  problem to two disturbance attenuation problems, which can be solved by well known methods, see, for example, References 16, 27, and 28.

APPENDIX B

In Appendix A solvability condition were given for the standard  $\mathcal{H}_\infty$  ‘singular’ problem, which were used in Sections 3 and 4 in terms of solvability of the quadratic matrix inequality. In this appendix we shall describe an explicit algorithm for solving the quadratic matrix inequality in the case of a totally singular system, i.e. to a system without a ‘D’ matrix. The solution to the quadratic matrix inequality is based on the subspaces  $\mathcal{R}_a^*$  and  $\mathcal{R}_b^*$  which are concepts from geometric control theory.<sup>27</sup> In Reference 20 the notation  $\mathcal{H}(\Sigma)$  has been used for  $\mathcal{R}_b^*$ , the strongly controllable subspace. For the convenience of the reader, we have listed the complete algorithm for the solution of the quadratic matrix inequality in the totally singular case, in matrix notation.

We shall introduce some notation:

$\mathbf{M}^\perp$  denotes a maximal kernel matrix of  $\mathbf{M}^T$ , i.e.,  $\mathbf{M}^\perp$  is a matrix satisfying  $\mathbf{M}^T \mathbf{M}^\perp = \mathbf{0}$ , with a maximal number of columns, and having full column Rank.

$\mathbf{K}$  denotes a right kernel matrix of  $\mathbf{C}_2$ , i.e.,  $\mathbf{K} = (\mathbf{C}_2^T)^\perp$ .

*Algorithm B.1*

Inputs:  $\gamma > 0$ . System matrices  $\mathbf{A}$ ,  $\mathbf{B}$ ,  $\mathbf{E}$  and  $\mathbf{C}_2$ .

- (1) Initializing:  $\mathbf{R}_0 = [\mathbf{K}^\perp \ \mathbf{B}^\perp]^\perp$ ,  $k = 1$ .
- (2) Calculate  $\mathbf{W} = [\mathbf{A}\mathbf{R}_k \ \mathbf{B}]$
- (3) Next iterate:  $\mathbf{R}_{k+1} = [\mathbf{K}^\perp \ \mathbf{W}^\perp]^\perp$ ,  $k = k + 1$ .
- (4) If  $k = n$  proceed to (5), else go to (2).
- (5) Define  $\mathbf{T}_2 = \mathbf{R}_n$  and let  $\mathbf{T}_1$  and  $\mathbf{T}_3$  be matrices such that  $\text{Im } \mathbf{W} = \text{Im } [\mathbf{T}_2 \ \mathbf{T}_3]$ , and  $\text{Rank } [\mathbf{T}_1 \ \mathbf{T}_2 \ \mathbf{T}_3] = n$ . In short,  $\mathbf{T}_3$  consists of columns from  $\mathbf{W}$  which are linearly independent of the columns in  $\mathbf{T}_2$ , and  $\mathbf{T}_1$  consist of arbitrary columns linearly interdependent of  $\mathbf{W}$ .
- (6) Calculate

$$[\mathbf{T}_1 \ \mathbf{T}_2 \ \mathbf{T}_3]^{-1} = \begin{bmatrix} \mathbf{S}_1 \\ \mathbf{S}_2 \\ \mathbf{S}_3 \end{bmatrix}$$

- (7) Define the following transformed matrices:

$$\begin{aligned} \tilde{\mathbf{A}}_{11} &= \mathbf{S}_1 \mathbf{A} \mathbf{T}_1, & \tilde{\mathbf{A}}_{13} &= \mathbf{S}_1 \mathbf{A} \mathbf{T}_3, & \tilde{\mathbf{C}}_{21} &= \mathbf{C}_2 \mathbf{T}_1, & \tilde{\mathbf{C}}_{23} &= \mathbf{C}_2 \mathbf{T}_3, & \tilde{\mathbf{A}} &= \tilde{\mathbf{A}}_{11} - \tilde{\mathbf{A}}_{13} (\tilde{\mathbf{C}}_{23}^\top \tilde{\mathbf{C}}_{23})^{-1} \tilde{\mathbf{C}}_{23}^\top \tilde{\mathbf{C}}_{21}, \\ \tilde{\mathbf{E}}_1 &= \mathbf{S}_1 \mathbf{E}, & \tilde{\mathbf{R}} &= \gamma^{-2} \tilde{\mathbf{E}}_1 \tilde{\mathbf{E}}_1^\top - \tilde{\mathbf{A}}_{13} (\tilde{\mathbf{C}}_{23}^\top \tilde{\mathbf{C}}_{23})^{-1} \tilde{\mathbf{A}}_{13}, & \tilde{\mathbf{Q}} &= \mathbf{C}_{21}^\top \tilde{\mathbf{C}}_{21} - \tilde{\mathbf{C}}_{21}^\top \tilde{\mathbf{C}}_{23} (\tilde{\mathbf{C}}_{23}^\top \tilde{\mathbf{C}}_{23})^{-1} \tilde{\mathbf{C}}_{23}^\top \tilde{\mathbf{C}}_{21}. \end{aligned}$$

- (8) Find the stabilizing solution to the reduced order Riccati equation:

$$\tilde{\mathbf{P}} \tilde{\mathbf{A}} + \tilde{\mathbf{A}}^\top \tilde{\mathbf{P}} + \tilde{\mathbf{P}} \tilde{\mathbf{R}} \tilde{\mathbf{P}} + \tilde{\mathbf{Q}} = 0$$

- (9) Calculate  $\mathbf{P} = \mathbf{S}_1^\top \tilde{\mathbf{P}} \mathbf{S}_1$ .

Output:  $\mathbf{P}$ .

*Theorem B.2*

Let matrices  $\mathbf{A}$ ,  $\mathbf{B}$ ,  $\mathbf{E}$  and  $\mathbf{C}_2$  be given as input for Algorithm B.1. Assume  $\gamma$  has been chosen sufficiently large, i.e.  $\gamma > \gamma^*$ . Then the output  $\mathbf{P}$  from Algorithm B.1 satisfies:

$$\begin{aligned} \mathbf{F}_\gamma(\mathbf{P}) &= \begin{bmatrix} \mathbf{A}^\top \mathbf{P} + \mathbf{P} \mathbf{A} + \mathbf{C}_2^\top \mathbf{C}_2 + \gamma^{-2} \mathbf{P} \mathbf{E} \mathbf{E}^\top \mathbf{P} & \mathbf{P} \mathbf{B} \\ \mathbf{B}^\top \mathbf{P} & \mathbf{0} \end{bmatrix} = \begin{bmatrix} \tilde{\mathbf{C}}_2^\top \\ \mathbf{0} \end{bmatrix} [\tilde{\mathbf{C}}_2 \ \mathbf{0}] \geq 0 \\ \text{rank } \mathbf{F}_\gamma(\mathbf{P}) &= \text{rank } \tilde{\mathbf{C}}_2 = \text{normrank } \mathbf{C}_2 (s\mathbf{I} - \mathbf{A})^{-1} \mathbf{B} \\ \text{rank } \begin{bmatrix} s\mathbf{I} - \mathbf{A} - \gamma^{-2} \mathbf{E} \mathbf{E}^\top \mathbf{P} & -\mathbf{B} \\ \tilde{\mathbf{C}}_2 & \mathbf{0} \end{bmatrix} &= n + \text{normrank } \mathbf{C}_2 (s\mathbf{I} - \mathbf{A})^{-1} \mathbf{B}, \quad \forall s \in \mathbb{C}^+ \cup \mathbb{C}^0 \end{aligned}$$

i.e.  $\mathbf{P}$  is the unique solution to the totally singular quadratic matrix inequality.

*Proof.* The purpose of steps (1)–(4) is to calculate the subspaces  $\mathcal{R}_a^*$  and  $\mathcal{R}_b^*$ . The present algorithm is merely matrix interpretations, merging some well-known algorithms in ‘geometrical’ style which can be found, for example, in References 20, 27, and 28. They are:

$$\text{ACSA: } \begin{cases} \mathcal{R}_0 = \emptyset \\ \mathcal{R}_{k+1} = \mathcal{K} \cap (\mathbf{A} \mathcal{R}_k + \mathcal{B}) \end{cases} \quad \text{and} \quad \text{ACSA': } \begin{cases} \mathcal{S}_0 = \emptyset \\ \mathcal{S}_{k+1} = \mathcal{B} + \mathbf{A}(\mathcal{K} \cap \mathcal{S}_k) \end{cases}$$

It is well known that  $\mathcal{R}_n = \mathcal{R}_a^*$  and  $\mathcal{S}_n = \mathcal{R}_b^*$  (in fact fewer iterations will always suffice). The effect of step (5) is to define a basis for the strongly controllable subspace  $\mathcal{R}_a^*$ , the columns of  $[\mathbf{T}_2 \ \mathbf{T}_3]$ , and a basis for a complement, the columns of  $\mathbf{T}_1$ . In Reference 20 it has been shown that  $\mathbf{P}$  only relates to the subsystem corresponding to  $\mathbf{T}_1$  which is then exploited in steps (6) and (7) to generate the *reduced order* Riccati equation in step (8).

The algorithms in this section and the solution to the reduced-order Riccati equation in Algorithm B.1 has been implemented as MATLAB programs, which are available on request (including floppy disk) to the authors.

APPENDIX C

In this appendix we shall give proofs of the results in Section 3.2.

The  $\mathcal{H}_\infty$ /LTR problem considered corresponds to the following standard problem:

$$\begin{aligned} \dot{x} &= \bar{A}x + \bar{B}u + \bar{E}w \\ y &= \bar{C}_1x + \bar{D}_1w \\ z &= \bar{C}_2x + \bar{D}_2u \end{aligned} \quad (C.1)$$

where:

$$\bar{A} = \begin{bmatrix} A + KC & 0 \\ BF & A + BF \end{bmatrix}, \quad \bar{B} = \begin{bmatrix} 0 \\ B \end{bmatrix}, \quad \bar{E} = \begin{bmatrix} B \\ 0 \end{bmatrix}, \quad \bar{C}_1 = [C \ 0], \quad \bar{D}_1 = 0, \quad \bar{C}_2 = [F \ F] \text{ and } \bar{D}_2 = I.$$

To apply the results from Section 3, we have to require that Assumption A.1 is satisfied, which means that the systems  $(\bar{A}, \bar{B}, \bar{C}_2, \bar{D}_2)$  and  $(\bar{A}, \bar{E}, \bar{C}_1, \bar{D}_1)$  have no zeros on the imaginary axis.

$$\text{rank} \begin{bmatrix} sI - \bar{A} & -\bar{B} \\ \bar{C}_2 & \bar{D}_2 \end{bmatrix} = 2n + m, \quad \forall s \in \mathbb{C}^0$$

⇕

$$\begin{bmatrix} sI - A - KC & 0 & 0 \\ -BF & sI - A - BF & -B \\ F & F & I \end{bmatrix} = 2n + m, \quad \forall s \in \mathbb{C}^0$$

⇕

$$\text{rank}[sI - A - KC] = n \wedge \text{rank} \begin{bmatrix} sI - A - BF & -B \\ F & I \end{bmatrix} = n + m, \quad \forall s \in \mathbb{C}^0$$

⇕

$$\text{rank}[sI - A - KC] = n \wedge \text{rank} \begin{bmatrix} sI - A & -B \\ 0 & I \end{bmatrix} = n + m, \quad \forall s \in \mathbb{C}^0$$

⇕

$$\Lambda(A + KC) \cap \mathbb{C}^0 = \Lambda(A) \cap \mathbb{C}^0 = \{ \} \quad (C.2)$$

$\Lambda(A + KC) \cap \mathbb{C}^0 = \{ \}$  follows from stability of  $A + KC$ , but  $\Lambda(A) \cap \mathbb{C}^0 = \{ \}$  is a condition which has to be taken into consideration.

Let  $\bar{m} = \text{normrank } \bar{D}_1 + \bar{C}_1(sI - \bar{A})^{-1}\bar{E} = \text{normrank } C(sI - A - KC)^{-1}B$ . Then, as above, we get:

$$\text{rank} \begin{bmatrix} sI - \bar{A} & -\bar{E} \\ \bar{C}_1 & \bar{D}_1 \end{bmatrix} = 2n + \bar{m}, \quad \forall s \in \mathbb{C}^0$$

⇕

$$\begin{bmatrix} sI - A - KC & 0 & -B \\ -BF & sI - A - BF & 0 \\ C & 0 & 0 \end{bmatrix} = 2n + \bar{m}, \quad \forall s \in \mathbb{C}^0$$

⇕

$$\text{rank}[sI - A - BF] = n \wedge \text{rank} \begin{bmatrix} sI - A - KC & -B \\ C & 0 \end{bmatrix} = n + \bar{m}, \quad \forall s \in \mathbb{C}^0$$

⇕

$$\text{rank}[sI - A - BF] = n \wedge \text{rank} \begin{bmatrix} sI - A & -B \\ C & 0 \end{bmatrix} = n + \bar{m}, \quad \forall s \in \mathbb{C}^0$$

⇕

$$\Lambda(A + BF) \cap \mathbb{C}^0 = \{ \} \text{ and } \mathcal{Z}(A, B, C, 0) \cap \mathbb{C}^0 = \{ \} \quad (C.2)$$

again  $\Lambda(A + BF) \cap \mathbb{C}^0 = \{ \}$  follows from stability of  $A + BF$ , whereas  $\mathcal{Z}(A, B, C, 0) \cap \mathbb{C}^0 = \{ \}$  is a non-trivial condition. Conclusively,  $(A, B, C, 0)$  must have neither zeros nor poles on the imaginary axis if we wish to apply the results from Appendix A.

*Proof of Theorem 3.1*

Let  $P$  be the stabilizing solution to the algebraic Riccati equation:

$$A^T P + PA - PBB^T P = 0 \quad (C.4)$$

We define:

$$\bar{\mathbf{P}} = \begin{bmatrix} \mathbf{0} & \mathbf{0} \\ \mathbf{0} & \mathbf{P} \end{bmatrix} \quad (\text{C.5})$$

Evaluating  $\bar{\mathbf{F}}_\gamma(\bar{\mathbf{P}})$  we get:

$$\begin{aligned} \bar{\mathbf{F}}_\gamma(\bar{\mathbf{P}}) &= \begin{bmatrix} \mathbf{F}^T \mathbf{F} & \mathbf{F}^T \mathbf{B}^T \mathbf{P} + \mathbf{F}^T \mathbf{F} & \mathbf{F}^T \\ \mathbf{P} \mathbf{B} \mathbf{F} + \mathbf{F}^T \mathbf{F} & \mathbf{A}^T \mathbf{P} + \mathbf{P} \mathbf{A} \mathbf{F} + \mathbf{F}^T \mathbf{F} & \mathbf{P} \mathbf{B} + \mathbf{F}^T \\ \mathbf{F} & \mathbf{B}^T \mathbf{P} + \mathbf{F} & \mathbf{I} \end{bmatrix} \\ &= \begin{bmatrix} \mathbf{F}^T \\ \mathbf{P} \mathbf{B} + \mathbf{F}^T \\ \mathbf{I} \end{bmatrix} \times [\mathbf{F} \ \mathbf{B}^T \mathbf{P} + \mathbf{F} \ \mathbf{I}] \geq \mathbf{0} \end{aligned} \quad (\text{C.6})$$

The last identity holds because:

$$(\mathbf{A} + \mathbf{B} \mathbf{F})^T \mathbf{P} + \mathbf{P} (\mathbf{A} + \mathbf{B} \mathbf{F}) + \mathbf{F}^T \mathbf{F} = \mathbf{P} \mathbf{B} \mathbf{B}^T \mathbf{P} + \mathbf{F}^T \mathbf{B}^T \mathbf{P} + \mathbf{P} \mathbf{B} \mathbf{F} + \mathbf{F}^T \mathbf{F} = (\mathbf{P} \mathbf{B} + \mathbf{F}^T) \times (\mathbf{B}^T \mathbf{P} + \mathbf{F}) \quad (\text{C.7})$$

Hence, for the full information transform we get  $\mathbf{C}_{2,\mathbf{P}} = [\mathbf{F} \ \mathbf{B}^T \mathbf{P} + \mathbf{F}]$  and  $\mathbf{D}_{\mathbf{P}} = \mathbf{I}$ .

The stability condition of Corollary A.3 amounts to:

$$\Lambda(\bar{\mathbf{A}} + \gamma^{-2} \bar{\mathbf{E}} \bar{\mathbf{E}}^T \mathbf{P} - \bar{\mathbf{B}} (\bar{\mathbf{D}}_2^T \bar{\mathbf{D}}_2)^{-1} (\bar{\mathbf{B}}^T \bar{\mathbf{P}} + \bar{\mathbf{D}}_2^T \bar{\mathbf{C}}_2)) \subset \mathbb{C}^-$$

⇕

$$\Lambda \begin{bmatrix} \mathbf{A} + \mathbf{K} \mathbf{C} & \mathbf{0} \\ \mathbf{0} & \mathbf{A} - \mathbf{B} \mathbf{B}^T \mathbf{P} \end{bmatrix} \subset \mathbb{C}^-$$

⇕

$$\Lambda(\mathbf{A} + \mathbf{K} \mathbf{C}) \subset \mathbb{C}^- \quad \text{and} \quad \Lambda(\mathbf{A} - \mathbf{B} \mathbf{B}^T \mathbf{P}) \subset \mathbb{C}^-$$

which is always satisfied, since  $\mathbf{A} + \mathbf{K} \mathbf{C}$  is stable by assumption, and  $\mathbf{P}$  is the stabilizing solution, which exists according to Theorem A.5. Note, that in the special case when  $\mathbf{A}$  is stable,  $\mathbf{P} = \mathbf{0}$  is the unique solution to (C.4), and thus  $\bar{\mathbf{P}} = \mathbf{0}$  is the unique solution to the quadratic matrix inequality.

### Proof of Corollary 3.3

For  $\bar{\mathbf{Y}} = \mathbf{0}$  we get:

$$\bar{\mathbf{G}}_\gamma(\bar{\mathbf{Y}}) = \begin{bmatrix} \mathbf{B} \mathbf{B}^T & \mathbf{0} & \mathbf{0} \\ \mathbf{0} & \mathbf{0} & \mathbf{0} \\ \mathbf{0} & \mathbf{0} & \mathbf{0} \end{bmatrix} = \begin{bmatrix} \mathbf{B} \\ \mathbf{0} \\ \mathbf{0} \end{bmatrix} \times [\mathbf{B}^T \ \mathbf{0} \ \mathbf{0}] \geq \mathbf{0}$$

Since  $\mathbf{H}(s) = \mathbf{C}(s\mathbf{I} - \mathbf{A} - \mathbf{K} \mathbf{C})^{-1} \mathbf{B}$ , from

$$\text{rank } \bar{\mathbf{G}}_\gamma(\bar{\mathbf{Y}}) = \mathbf{H}(s)$$

we obtain the condition that  $(\mathbf{A}, \mathbf{B}, \mathbf{C}, \mathbf{0})$  is right invertible, i.e., we have effectively at least as many inputs as outputs.

From Theorem A.2(6) we get the following.

⇕

$$\text{rank } [\bar{\mathbf{M}}_\gamma(\bar{\mathbf{Y}}, s) \ \bar{\mathbf{G}}_\gamma(\bar{\mathbf{Y}})] = 2n + \text{normrank } \mathbf{H}(s), \quad \forall s \in \bar{\mathbb{C}}^+$$

$$\text{rank} \begin{bmatrix} s\mathbf{I} - \mathbf{A} - \mathbf{K} \mathbf{C} & \mathbf{0} & \mathbf{B} \\ \mathbf{B} \mathbf{F} & s\mathbf{I} - \mathbf{A} - \mathbf{B} \mathbf{F} & \mathbf{0} \\ -\mathbf{C} & \mathbf{0} & \mathbf{0} \end{bmatrix} = 2n + \text{normrank } \mathbf{H}(s), \quad \forall s \in \bar{\mathbb{C}}^+$$

⇕

$$\text{rank } [s\mathbf{I} - \mathbf{A} - \mathbf{B} \mathbf{F}] = n \wedge \begin{bmatrix} s\mathbf{I} - \mathbf{A} - \mathbf{K} \mathbf{C} & \mathbf{B} \\ -\mathbf{C} & \mathbf{0} \end{bmatrix} = n + \text{normrank } \mathbf{H}(s), \quad \forall s \in \bar{\mathbb{C}}^+$$

⇕

$$\text{rank } [s\mathbf{I} - \mathbf{A} - \mathbf{B} \mathbf{F}] = n \wedge \begin{bmatrix} s\mathbf{I} - \mathbf{A} & \mathbf{B} \\ -\mathbf{C} & \mathbf{0} \end{bmatrix} = n + \text{normrank } \mathbf{H}(s), \quad \forall s \in \bar{\mathbb{C}}^+$$

Thus, necessary and sufficient conditions for  $\bar{\mathbf{Y}} = \mathbf{0}$  to be a solution is that  $\mathbf{A} + \mathbf{B} \mathbf{F}$  is stable, and that  $(\mathbf{A}, \mathbf{B}, \mathbf{C}, \mathbf{0})$  is minimum phase and right-invertible.

*Proof of Theorem 3.5*

Theorem 3.5 is proved by showing that the closed loop transfer functions between  $w$  to  $z$  is the same for the two systems in Figure 4. Utilizing:

$$E_S(s) = S_{TFL}(s)M_1(s)$$

and

$$E_S^*(s) = S_{TFL}(s)M_1^*(s)$$

it is seen, that it suffices to prove that  $M_1(s) = M_1^*(s)$

$$\begin{aligned} M_1(s) &= T_1(s) + Q(s)T_2(s) \\ &= F(sI - A - KC)^{-1}B + Q(s)C(sI - A - KC)^{-1}B \\ &= F(sI - A - KC)^{-1}B \\ &\quad + [F(sI - A - KC - M_1C)^{-1}M_1 + (B^T P + F)(sI - A + BB^T P)^{-1}M_2C(sI - A - KC - M_1C)^{-1}M_1 \\ &\quad + (B^T P + F)(sI - A + BB^T P)^{-1}M_2]C(sI - A - KC)^{-1}B \\ &= F(I + (sI - A + BB^T P)^{-1}M_2C)(I + (sI - A - KC - M_1C)^{-1}M_1C)(sI - A - KC)^{-1}B \\ &\quad + B^T P(sI - A + BB^T P)^{-1}M_2C(I + (sI - A - KC - M_1C)^{-1}M_1C)(sI - A - KC)^{-1}B \\ &= [F(I + (sI - A + BB^T P)^{-1}M_2C) + B^T P(sI - A + BB^T P)^{-1}M_2C](sI - A - KC - M_1C)^{-1}B \\ &= F(sI - A - (K + M_1)C)^{-1}B + (F + B^T P)(sI - A + BB^T P)^{-1}M_2C(sI - A - (K + M_1)C)^{-1}B \\ &= T_1^*(s) + Q^*(s)T_2^*(s) \\ &= M_1^*(s) \end{aligned}$$

APPENDIX D

*Proof of Theorem 3.7*

Let  $P$  be the stabilizing solution to the algebraic Riccati equation:

$$A^T P + PA - PBB^T P = 0 \tag{D.1}$$

We define

$$\bar{P} = \begin{bmatrix} P & -P \\ -P & P \end{bmatrix} \tag{D.2}$$

The associated quadratic matrix becomes:

$$\begin{aligned} \bar{F}_\gamma(\bar{P}) &= \begin{bmatrix} A^T P + PA & -A^T P - PA - PBF & PB \\ -A^T P - F^T B^T P - PA & A^T P + F^T B^T P + PA + PBF + F^T F & -PB - F^T \\ B^T P & -B^T P - F & I \end{bmatrix} \\ &= \begin{bmatrix} PBB^T P & -PBB^T P - PBF & PB \\ -PBB^T P - F^T B^T P & PBB^T P + PBF + F^T B^T P + F^T F & -PB - F^T \\ B^T P & -B^T P - F & I \end{bmatrix} \end{aligned} \tag{D.4}$$

$$= \begin{bmatrix} -PB \\ PB + F^T \\ -I \end{bmatrix} \times \begin{bmatrix} -B^T P & B^T P + F & -I \end{bmatrix} \tag{D.5}$$

The Riccati equation (D.1) has been exploited to obtain (D.4).

The stability condition of Corollary A.3 amounts to:

$$\Lambda(\bar{A} + \gamma^{-2} \bar{E} \bar{E}^T \bar{P} - \bar{B}(\bar{D}_2^T \bar{D}_2)^{-1}(\bar{B}^T \bar{P} + \bar{D}_2^T \bar{C}_2)) \subset \mathbb{C}^-$$

⇕

$$\Lambda \begin{bmatrix} A - BB^T P & B(F - B^T P) \\ 0 & A + BF \end{bmatrix} \subset \mathbb{C}^-$$

⇕

$$\Lambda(A + BF) \subset \mathbb{C}^- \quad \text{and} \quad \Lambda(A - BB^T P) \subset \mathbb{C}^-$$



which is always satisfied, since  $\mathbf{A} + \mathbf{B}\mathbf{F}$  is stable by assumption, and  $\mathbf{P}$  is the stabilizing solution to (D.1), which exists according to Theorem A.5. Note, that in the special case when  $\mathbf{A}$  is stable,  $\mathbf{P} = \mathbf{0}$  is the unique solution to (D.1), and consequently  $\bar{\mathbf{P}} = \mathbf{0}$  is the unique solution to the quadratic matrix inequality.

*Proof of Lemma 3.11*

Let the observer gain  $\mathbf{M}$  be given by:

$$\mathbf{M} = \begin{bmatrix} \mathbf{N} \\ \mathbf{N} \end{bmatrix} \quad (\text{D.6})$$

where  $\mathbf{N}$  satisfies  $\Lambda(\mathbf{A} + \mathbf{N}\mathbf{C}) \in \mathbb{C}^-$ . Then  $\mathbf{N}$  stabilizes  $\bar{\mathbf{A}} + \mathbf{M}\bar{\mathbf{C}}_1$  since:

$$\Lambda(\bar{\mathbf{A}} + \mathbf{M}\bar{\mathbf{C}}_1) = \Lambda \begin{bmatrix} \mathbf{A} + \mathbf{N}\mathbf{C} & \mathbf{0} \\ \mathbf{N}\mathbf{C} & \mathbf{A} + \mathbf{B}\mathbf{F} \end{bmatrix} + \Lambda(\mathbf{A} + \mathbf{N}\mathbf{C}) \uplus \Lambda(\mathbf{A} + \mathbf{B}\mathbf{F}) \in \mathbb{C}^- \quad (\text{D.7})$$

and both  $\mathbf{A} + \mathbf{N}\mathbf{C}$  and  $\mathbf{A} + \mathbf{B}\mathbf{F}$  are stable by definition.

For the norm bound in (73) we have:

$$\begin{aligned} & \| \bar{\mathbf{C}}_{2,P}(s\mathbf{I} - \bar{\mathbf{A}}_{P,Q} - \mathbf{M}\bar{\mathbf{C}}_1)^{-1} \mathbf{E}_{P,Q} \|_\infty \\ &= \left\| \begin{bmatrix} -\mathbf{B}^T\mathbf{P} & \mathbf{B}^T\mathbf{P} + \mathbf{F} \end{bmatrix} \begin{bmatrix} s\mathbf{I} - \mathbf{A} - \mathbf{N}\mathbf{C} & \mathbf{0} \\ -\mathbf{N}\mathbf{C} & s\mathbf{I} - \mathbf{A} - \mathbf{B}\mathbf{F} \end{bmatrix}^{-1} \begin{bmatrix} \mathbf{B} \\ \mathbf{B} \end{bmatrix} \right\|_\infty \\ &= \| (-\mathbf{B}^T\mathbf{P} + (\mathbf{B}^T\mathbf{P} + \mathbf{F})(s\mathbf{I} - \mathbf{A} - \mathbf{B}\mathbf{F})^{-1}(s\mathbf{I} - \mathbf{A})) (s\mathbf{I} - \mathbf{A} - \mathbf{N}\mathbf{C})^{-1} \mathbf{B} \|_\infty \\ &= \| (\mathbf{F} + (\mathbf{B}^T\mathbf{P} + \mathbf{F})(s\mathbf{I} - \mathbf{A} - \mathbf{B}\mathbf{F})^{-1} \mathbf{B}\mathbf{F})(s\mathbf{I} - \mathbf{A} - \mathbf{N}\mathbf{C})^{-1} \mathbf{B} \|_\infty \end{aligned} \quad (\text{D.8})$$

Hence, if:

$$\| (s\mathbf{I} - \mathbf{A} - \mathbf{N}\mathbf{C})^{-1} \mathbf{B} \|_\infty < \tilde{\gamma} \quad (\text{D.9})$$

where:

$$\tilde{\gamma} = \gamma / \| \mathbf{F} + (\mathbf{B}^T\mathbf{P} + \mathbf{F})(s\mathbf{I} - \mathbf{A} - \mathbf{B}\mathbf{F})^{-1} \mathbf{B}\mathbf{F} \|_\infty \quad (\text{D.10})$$

then we have:

$$\| \bar{\mathbf{C}}_{2,P}(s\mathbf{I} - \bar{\mathbf{A}}_{P,Q} - \mathbf{M}\bar{\mathbf{C}}_1)^{-1} \bar{\mathbf{E}}_{P,Q} \|_\infty < \gamma \quad (\text{D.11})$$

The existence of  $\mathbf{N}$  satisfying (D.9) is guaranteed by the hypothesis  $\bar{\mathbf{Y}} = \mathbf{0}$ , since it is easily seen that this implies that  $(\mathbf{A}, \mathbf{B}, \mathbf{C}, \mathbf{0})$  is a minimum phase system, i.e. that the  $\mathcal{H}_\infty$  norm of  $(s\mathbf{I} - \mathbf{A} - \mathbf{N}\mathbf{C})^{-1} \mathbf{B}$  can be made arbitrarily small.

The 2 $n$ th-order controller  $\mathbf{Q}(s)$  in (74) with  $\mathbf{M} = [\mathbf{N}^T \ \mathbf{N}^T]^T$  becomes:

$$\mathbf{Q}(s) = \begin{bmatrix} -\mathbf{B}^T\mathbf{P} & \mathbf{B}^T\mathbf{P} + \mathbf{F} \end{bmatrix} \begin{bmatrix} s\mathbf{I} - \mathbf{A} + \mathbf{B}\mathbf{B}^T\mathbf{P} - \mathbf{N}\mathbf{C} & -\mathbf{B}\mathbf{B}^T\mathbf{P} - \mathbf{B}\mathbf{F} \\ -\mathbf{N}\mathbf{C} & s\mathbf{I} - \mathbf{A} - \mathbf{B}\mathbf{F} \end{bmatrix}^{-1} \begin{bmatrix} \mathbf{N} \\ \mathbf{N} \end{bmatrix} \quad (\text{D.12})$$

By introducing the following similarity transformation of the controller states:

$$\mathbf{T} = \begin{bmatrix} \mathbf{I} & \mathbf{0} \\ -\mathbf{I} & \mathbf{I} \end{bmatrix}, \quad \mathbf{T}^{-1} = \begin{bmatrix} \mathbf{I} & \mathbf{0} \\ \mathbf{I} & \mathbf{I} \end{bmatrix} \quad (\text{D.13})$$

we obtain:

$$\begin{aligned} \mathbf{Q}(s) &= \begin{bmatrix} -\mathbf{B}^T\mathbf{P} & \mathbf{B}^T\mathbf{P} + \mathbf{F} \end{bmatrix} \mathbf{T}^{-1} \mathbf{T} \begin{bmatrix} s\mathbf{I} - \mathbf{A} + \mathbf{B}\mathbf{B}^T\mathbf{P} - \mathbf{N}\mathbf{C} & -\mathbf{B}\mathbf{B}^T\mathbf{P} - \mathbf{B}\mathbf{F} \\ -\mathbf{N}\mathbf{C} & s\mathbf{I} - \mathbf{A} - \mathbf{B}\mathbf{F} \end{bmatrix}^{-1} \mathbf{T}^{-1} \mathbf{T} \begin{bmatrix} \mathbf{N} \\ \mathbf{N} \end{bmatrix} \\ &= \begin{bmatrix} \mathbf{F} & \mathbf{B}^T\mathbf{P} + \mathbf{F} \end{bmatrix} \begin{bmatrix} s\mathbf{I} - \mathbf{A} - \mathbf{B}\mathbf{F} - \mathbf{N}\mathbf{C} & -\mathbf{B}\mathbf{B}^T\mathbf{P} - \mathbf{B}\mathbf{F} \\ \mathbf{0} & s\mathbf{I} - \mathbf{A} + \mathbf{B}\mathbf{B}^T\mathbf{P} \end{bmatrix}^{-1} \begin{bmatrix} \mathbf{N} \\ \mathbf{0} \end{bmatrix} \\ &= \mathbf{F}(s\mathbf{I} - \mathbf{A} - \mathbf{B}\mathbf{F} - \mathbf{N}\mathbf{C})^{-1} \mathbf{N} \end{aligned} \quad (\text{D.14})$$

This is obviously an  $n$ th-order controller, actually a standard full-order observer based controller. Applying this controller the sensitivity recovery error becomes:

$$\begin{aligned} \mathbf{E}_S(s) &= \mathbf{F}(s\mathbf{I} - \mathbf{A} - \mathbf{BF})^{-1}\mathbf{B} - \mathbf{Q}(s) [\mathbf{I} - \mathbf{C}(s\mathbf{I} - \mathbf{A})^{-1}\mathbf{B}\mathbf{Q}(s)]^{-1}\mathbf{C}(s\mathbf{I} - \mathbf{A})^{-1}\mathbf{B} \\ &= \mathbf{F}(s\mathbf{I} - \mathbf{A} - \mathbf{BF})^{-1}\mathbf{B} - \mathbf{F}(s\mathbf{I} - \mathbf{A} - \mathbf{BF} - \mathbf{NC})^{-1}\mathbf{N}[\mathbf{I} - \mathbf{C}(s\mathbf{I} - \mathbf{A})^{-1} \\ &\quad \times \mathbf{BF}(s\mathbf{I} - \mathbf{A} - \mathbf{BF} - \mathbf{NC})^{-1}\mathbf{N}]^{-1}\mathbf{C}(s\mathbf{I} - \mathbf{A})^{-1}\mathbf{B} \\ &= (\mathbf{I} + \mathbf{F}(s\mathbf{I} - \mathbf{A} - \mathbf{BF})^{-1}\mathbf{B})\mathbf{F}(s\mathbf{I} - \mathbf{A} - \mathbf{NC})^{-1}\mathbf{B} \end{aligned} \quad (\text{D.15})$$

Since  $(\mathbf{A}, \mathbf{B}, \mathbf{C}, \mathbf{0})$  is minimum phase  $\|(s\mathbf{I} - \mathbf{A} - \mathbf{NC})^{-1}\mathbf{B}\|_\infty$  can be made arbitrarily small. Especially we can choose  $\mathbf{N}$  such that:

$$\|(s\mathbf{I} - \mathbf{A} - \mathbf{NC})^{-1}\mathbf{B}\|_\infty < \gamma (\|(\mathbf{I} + \mathbf{F}(s\mathbf{I} - \mathbf{A} - \mathbf{BF})^{-1}\mathbf{B})\mathbf{F}\|_\infty)^{-1} \quad (\text{D.16})$$

or

$$\|\mathbf{E}_S(\cdot)\|_\infty \leq \|(s\mathbf{I} - \mathbf{A} - \mathbf{NC})^{-1}\mathbf{B}\|_\infty \|(\mathbf{I} + \mathbf{F}(s\mathbf{I} - \mathbf{A} - \mathbf{BF})^{-1}\mathbf{B})\mathbf{F}\|_\infty < \gamma \quad (\text{D.17})$$

This completes the proof of Lemma 3.11.

## APPENDIX E

### Proof of Theorem 4.1

We consider the system  $\Sigma_{10,Q}$  described by (78). But first we introduce the following auxiliary system:

$$\Sigma^*: \begin{cases} \dot{\mathbf{x}} = \mathbf{A}\mathbf{x} + \mathbf{B}\mathbf{u} + \mathbf{0}\mathbf{w} \\ \mathbf{y} = \mathbf{C}\mathbf{x} \quad + \mathbf{0}\mathbf{w} \\ \mathbf{z} = \mathbf{C}\mathbf{x} + \mathbf{0}\mathbf{u} \end{cases} \quad (\text{E.1})$$

Since this system is stabilizable and detectable, for  $\gamma$  sufficiently large the corresponding quadratic matrix inequality has a solution,  $\mathbf{P}$ . According to Corollary A.4 the quadratic matrix inequality for  $\Sigma^*$  reduced to:

$$\mathbf{A}^T\mathbf{P} + \mathbf{P}\mathbf{A} + \mathbf{C}^T\mathbf{C} \geq \mathbf{0} \quad (\text{E.2})$$

which is *independent of*  $\gamma$ . Also the associated rank conditions are independent of  $\gamma$ :

$$\text{rank}(\mathbf{A}^T\mathbf{P} + \mathbf{P}\mathbf{A} + \mathbf{C}^T\mathbf{C}) = \text{rank} \mathbf{C}_{2,P}^T \mathbf{C}_{2,P} = r \quad (\text{E.3})$$

and

$$\text{rank} \begin{bmatrix} s\mathbf{I} - \mathbf{A} & \mathbf{B} \\ \mathbf{C}_{2,P} & \mathbf{0} \end{bmatrix} = n + r, \quad \forall s \in \mathbb{C}^+ \quad (\text{E.4})$$

Hence, the unique solution to the quadratic matrix inequality for all  $\gamma$  is the solution to the dissipation inequality for the system  $\Sigma^*$ . (The almost disturbance decoupling problem is solvable for  $\Sigma^*$ , since  $\Sigma^*$  is stabilizable and  $\text{Im } \mathbf{E} \subset \text{Im } \mathbf{B}$ ). We claim that

$$\bar{\mathbf{P}} = \begin{bmatrix} \mathbf{0} & \mathbf{0} \\ \mathbf{0} & \mathbf{P} \end{bmatrix} \quad (\text{E.5})$$

is a solution to the quadratic matrix inequality for  $\Sigma_{10,Q}$ . By evaluating  $\bar{\mathbf{F}}_\gamma(\bar{\mathbf{P}})$  we get:

$$\bar{\mathbf{F}}_\gamma(\bar{\mathbf{P}}) = \begin{bmatrix} \mathbf{0} & \mathbf{0} & \mathbf{0} \\ \mathbf{0} & \mathbf{A}^T\mathbf{P} + \mathbf{P}\mathbf{A} + \mathbf{C}^T\mathbf{C} & \mathbf{0} \\ \mathbf{0} & \mathbf{0} & \mathbf{0} \end{bmatrix} = \begin{bmatrix} \mathbf{0} \\ \mathbf{C}_{2,P}^T \\ \mathbf{0} \end{bmatrix} \times [\mathbf{0} \ \mathbf{C}_{2,P} \ \mathbf{0}] \geq \mathbf{0} \quad (\text{E.6})$$

For the rank condition (3) in Theorem A.2 we get:  $\text{rank } \bar{\mathbf{F}}_\gamma(\bar{\mathbf{P}}) = \text{rank } \mathbf{C}_{2,P} = r$ , by (E.3). The other rank

condition, Theorem A.2(5), amounts to:

$$\begin{aligned}
 & \text{rank} \begin{bmatrix} s\mathbf{I} - \bar{\mathbf{A}} & -\bar{\mathbf{B}} \\ \bar{\mathbf{C}}_{2,P} & \bar{\mathbf{D}}_P \end{bmatrix} = n + \text{normrank } \bar{\mathbf{G}}, \quad \forall s \in \bar{\mathbf{C}}^+ \\
 \Downarrow & \\
 & \text{rank} \begin{bmatrix} s\mathbf{I} - \mathbf{A} - \mathbf{KC} & \mathbf{0} & \mathbf{0} \\ -\mathbf{B} & s\mathbf{I} - \mathbf{A} - \mathbf{BF} & -\mathbf{B} \\ \mathbf{0} & \mathbf{C}_{2,P} & \mathbf{0} \end{bmatrix} = 2n + \text{normrank}(\mathbf{C}(s\mathbf{I} - \mathbf{A} - \mathbf{BF})^{-1}\mathbf{B}), \quad \forall s \in \bar{\mathbf{C}}^+ \\
 \Downarrow & \\
 \Downarrow & \\
 & \text{rank}[s\mathbf{I} - \mathbf{A} - \mathbf{KC}] + \text{rank} \begin{bmatrix} s\mathbf{I} - \mathbf{A} - \mathbf{BF} & -\mathbf{B} \\ \mathbf{C}_{2,P} & \mathbf{0} \end{bmatrix} = 2n + \text{normrank}(\mathbf{C}(s\mathbf{I} - \mathbf{A} - \mathbf{BF})^{-1}\mathbf{B}), \quad \forall s \in \bar{\mathbf{C}}^+ \\
 \Downarrow & \\
 & \text{rank}[s\mathbf{I} - \mathbf{A} - \mathbf{KC}] = n \wedge \text{rank} \begin{bmatrix} s\mathbf{I} - \mathbf{A} & -\mathbf{B} \\ \mathbf{C}_{2,P} & \mathbf{0} \end{bmatrix} = n + r, \quad \forall s \in \bar{\mathbf{C}}^+ \tag{E.7}
 \end{aligned}$$

which follows by (E.4) and stability of  $\mathbf{A} + \mathbf{KC}$ .

#### Proof of Lemma 4.5

Consider the system:

$$\Sigma_{P,Q}: \begin{cases} \dot{\mathbf{x}} = (\mathbf{A} + \mathbf{BF} + \gamma^{-2}\mathbf{Y}_{22}\mathbf{C}_{2,P}^T\mathbf{C}_{2,P})\mathbf{x} + \mathbf{B}u \\ \mathbf{z} = \mathbf{C}_{2,P}\mathbf{x} + \mathbf{0}u \end{cases} \tag{E.8}$$

The system  $\Sigma_{P,Q}$  is minimum phase<sup>20</sup> since:

$$\text{rank} \begin{bmatrix} s\mathbf{I} - \mathbf{A} - \mathbf{BF} - \gamma^{-2}\mathbf{Y}_{22}\mathbf{C}_{2,P}^T\mathbf{C}_{2,P} & -\mathbf{B} \\ \mathbf{C}_{2,P} & \mathbf{0} \end{bmatrix} = \text{rank} \begin{bmatrix} s\mathbf{I} - \mathbf{A} & -\mathbf{B} \\ \mathbf{C}_{2,P} & \mathbf{0} \end{bmatrix} = n + \text{rank } \mathbf{C}_{2,P} \quad \forall s \in \bar{\mathbf{C}}^+ \tag{E.9}$$

where the last identity holds according to (81).

Thus, by the minimum phase property,<sup>20</sup>  $\forall \epsilon > 0$  there exists an  $\mathbf{L}$  such that  $\mathbf{A} + \mathbf{BF} + \gamma^{-2}\mathbf{Y}_{22}\mathbf{C}_{2,P}^T\mathbf{C}_{2,P} + \mathbf{BL}$  is stable, and

$$\|\mathbf{C}_{2,P}(s\mathbf{I} - \mathbf{A} - \mathbf{BF} - \gamma^{-2}\mathbf{Y}_{22}\mathbf{C}_{2,P}^T\mathbf{C}_{2,P} - \mathbf{BL})^{-1}\| < \epsilon \tag{E.9}$$

Now substituting  $\mathbf{L}_1 = -\mathbf{F}$  in:

$$[\mathbf{0} \ \mathbf{C}_{2,P}] \times \begin{bmatrix} s\mathbf{I} - \mathbf{A} - \mathbf{KC} & -\gamma^{-2}\mathbf{Y}_{12}\mathbf{C}_{2,P}^T\mathbf{C}_{2,P} \\ -\mathbf{BF} - \mathbf{BL}_1 & s\mathbf{I} - \mathbf{A} - \mathbf{BF} - \gamma^{-2}\mathbf{Y}_{22}\mathbf{C}_{2,P}^T\mathbf{C}_{2,P} - \mathbf{BL}_2 \end{bmatrix}^{-1} \tag{E.10}$$

we obtain:

$$\begin{aligned}
 & [\mathbf{0} \ \mathbf{C}_{2,P}] \times \begin{bmatrix} s\mathbf{I} - \mathbf{A} - \mathbf{KC} & -\gamma^{-2}\mathbf{Y}_{12}\mathbf{C}_{2,P}^T\mathbf{C}_{2,P} \\ \mathbf{0} & s\mathbf{I} - \mathbf{A} - \mathbf{BF} - \gamma^{-2}\mathbf{Y}_{22}\mathbf{C}_{2,P}^T\mathbf{C}_{2,P} - \mathbf{BL}_2 \end{bmatrix}^{-1} \\
 & = \mathbf{C}_{2,P}(s\mathbf{I} - \mathbf{A} - \mathbf{BF} - \gamma^{-2}\mathbf{Y}_{22}\mathbf{C}_{2,P}^T\mathbf{C}_{2,P} - \mathbf{BL}_2)^{-1} \tag{E.11}
 \end{aligned}$$

The  $\mathcal{H}_\infty$  norm of this expression can be made arbitrarily small, i.e., especially smaller than  $\gamma/(3 \cdot \|\mathbf{E}_{P,Q}\|)$ , hence satisfying (A.12) and eventually proving Lemma 4.5.

#### Proof of Theorem 4.6

The controller obtained in Lemma 4.5 was;

$$\begin{aligned}
 \mathbf{Q}(s) &= [\mathbf{F} \ -\mathbf{L}_2] \times \begin{bmatrix} s\mathbf{I} - \mathbf{A} - \mathbf{KC} - \mathbf{M}_1\mathbf{C} & -\gamma^{-2}\mathbf{Y}_{12}\mathbf{C}_{2,P}^T\mathbf{C}_{2,P} \\ -\mathbf{M}_2\mathbf{C} & s\mathbf{I} - \mathbf{A} - \mathbf{BF} - \gamma^{-2}\mathbf{Y}_{22}\mathbf{C}_{2,P}^T\mathbf{C}_{2,P} - \mathbf{BL}_2 \end{bmatrix}^{-1} \times \begin{bmatrix} \mathbf{M}_1 \\ \mathbf{M}_2 \end{bmatrix} \\
 &= [\mathbf{F} \ -\mathbf{L}_2] \times \begin{bmatrix} d_{11} & d_{12} \\ d_{21} & d_{22} \end{bmatrix} \times \begin{bmatrix} \mathbf{M}_1 \\ \mathbf{M}_2 \end{bmatrix} \tag{E.12}
 \end{aligned}$$

where

$$\begin{aligned} d_{11} &= (s\mathbf{I} - \mathbf{A} - \mathbf{K}\mathbf{C} - \mathbf{M}_1\mathbf{C})^{-1} + \gamma^{-2}(s\mathbf{I} - \mathbf{A} - \mathbf{K}\mathbf{C} - \mathbf{M}_1\mathbf{C})^{-1}\mathbf{Y}_{12}\mathbf{C}_{2,P}^T\mathbf{C}_{2,P}\Delta^{-1}\mathbf{M}_2\mathbf{C}(s\mathbf{I} - \mathbf{A} - \mathbf{K}\mathbf{C} - \mathbf{M}_1\mathbf{C})^{-1} \\ d_{12} &= \gamma^{-2}(s\mathbf{I} - \mathbf{A} - \mathbf{K}\mathbf{C} - \mathbf{M}_1\mathbf{C})^{-1}\mathbf{Y}_{12}\mathbf{C}_{2,P}^T\mathbf{C}_{2,P}\Delta^{-1} \\ d_{21} &= \Delta^{-1}\mathbf{M}_2\mathbf{C}(s\mathbf{I} - \mathbf{A} - \mathbf{K}\mathbf{C} - \mathbf{M}_1\mathbf{C})^{-1} \\ d_{22} &= \Delta^{-1} = (s\mathbf{I} - \mathbf{A} - \mathbf{B}\mathbf{F} - \gamma^{-2}\mathbf{Y}_{22}\mathbf{C}_{2,P}^T\mathbf{C}_{2,P} - \mathbf{B}\mathbf{L}_2 - \gamma^{-2}\mathbf{M}_2\mathbf{C}(s\mathbf{I} - \mathbf{A} - \mathbf{K}\mathbf{C} - \mathbf{M}_1\mathbf{C})^{-1}\mathbf{Y}_{12}\mathbf{C}_{2,P}^T\mathbf{C}_{2,P})^{-1} \\ &= \Phi + \gamma^{-2}\Phi\mathbf{M}_2\mathbf{C}(\gamma^{-2}\mathbf{Y}_{12}\mathbf{C}_{2,P}^T\mathbf{C}_{2,P}\Phi\mathbf{M}_2\mathbf{C} - (s\mathbf{I} - \mathbf{A} - \mathbf{K}\mathbf{C} - \mathbf{M}_1\mathbf{C}))^{-1}\mathbf{Y}_{12}\mathbf{C}_{2,P}^T\mathbf{C}_{2,P}\Phi \end{aligned}$$

with:

$$\Phi = (s\mathbf{I} - \mathbf{A} - \mathbf{B}\mathbf{F} - \gamma^{-2}\mathbf{Y}_{22}\mathbf{C}_{2,P}^T\mathbf{C}_{2,P} - \mathbf{B}\mathbf{L}_2)^{-1}$$

In this notation we have

$$\mathbf{Q}(s) = \mathbf{F}d_{11}\mathbf{M}_1 + \mathbf{F}d_{12}\mathbf{M}_2 - \mathbf{L}_2d_{21}\mathbf{M}_1 - \mathbf{L}_2d_{22}\mathbf{M}_2$$

Using this we obtain the following expression for  $\mathbf{M}_1$ :

$$\begin{aligned} \mathbf{M}_1(s) &= \mathbf{F}\Phi\mathbf{K}\mathbf{B} + \mathbf{Q}(s)\mathbf{C}\Phi\mathbf{K}\mathbf{B} \\ &= \mathbf{F}\Phi\mathbf{K}\mathbf{B} + \mathbf{F}d_{11}\mathbf{M}_1\mathbf{C}\Phi\mathbf{K}\mathbf{B} + \mathbf{F}d_{12}\mathbf{M}_2\mathbf{C}\Phi\mathbf{K}\mathbf{B} - \mathbf{L}_2d_{21}\mathbf{M}_1\mathbf{C}\Phi\mathbf{K}\mathbf{B} - \mathbf{L}_2d_{22}\mathbf{M}_2\mathbf{C}\Phi\mathbf{K}\mathbf{B} \\ &= [\mathbf{F} + \mathbf{F}(s\mathbf{I} - \mathbf{A} - \mathbf{K}\mathbf{C} - \mathbf{M}_1\mathbf{C})^{-1}\mathbf{M}_1\mathbf{C} \\ &\quad + \gamma^{-2}\mathbf{F}(s\mathbf{I} - \mathbf{A} - \mathbf{K}\mathbf{C} - \mathbf{M}_1\mathbf{C})^{-1}\mathbf{Y}_{12}\mathbf{C}_{2,P}^T\mathbf{C}_{2,P}\Delta^{-1}\mathbf{M}_2\mathbf{C}(s\mathbf{I} - \mathbf{A} - \mathbf{K}\mathbf{C} - \mathbf{M}_1\mathbf{C})^{-1}\mathbf{M}_1\mathbf{C} \\ &\quad + \gamma^{-2}\mathbf{F}(s\mathbf{I} - \mathbf{A} - \mathbf{K}\mathbf{C} - \mathbf{M}_1\mathbf{C})^{-1}\mathbf{Y}_{12}\mathbf{C}_{2,P}^T\mathbf{C}_{2,P}\Delta^{-1}\mathbf{M}_2\mathbf{C} \\ &\quad - \mathbf{L}_2\Delta^{-1}\mathbf{M}_2\mathbf{C}(s\mathbf{I} - \mathbf{A} - \mathbf{K}\mathbf{C} - \mathbf{M}_1\mathbf{C})^{-1}\mathbf{M}_1\mathbf{C} - \mathbf{L}_2\Delta^{-1}\mathbf{M}_2\mathbf{C}] \Phi\mathbf{K}\mathbf{B} \\ &= (\mathbf{F} + \gamma^{-2}\mathbf{F}(s\mathbf{I} - \mathbf{A} - \mathbf{K}\mathbf{C} - \mathbf{M}_1\mathbf{C})^{-1}\mathbf{Y}_{12}\mathbf{C}_{2,P}^T\mathbf{C}_{2,P}\Delta^{-1}\mathbf{M}_2\mathbf{C} - \mathbf{L}_2\Delta^{-1}\mathbf{M}_2\mathbf{C}) \\ &\quad \times (\mathbf{I} + (s\mathbf{I} - \mathbf{A} - \mathbf{K}\mathbf{C} - \mathbf{M}_1\mathbf{C})^{-1}\mathbf{M}_1\mathbf{C})\Phi\mathbf{K}\mathbf{B} \\ &= (\mathbf{F} + \gamma^{-2}\mathbf{F}(s\mathbf{I} - \mathbf{A} - \mathbf{K}\mathbf{C} - \mathbf{M}_1\mathbf{C})^{-1}\mathbf{Y}_{12}\mathbf{C}_{2,P}^T\mathbf{C}_{2,P}\Delta^{-1}\mathbf{M}_2\mathbf{C} - \mathbf{L}_2\Delta^{-1}\mathbf{M}_2\mathbf{C})(s\mathbf{I} - \mathbf{A} - \mathbf{K}\mathbf{C} - \mathbf{M}_1\mathbf{C})^{-1}\mathbf{B} \\ &= \mathbf{F}(s\mathbf{I} - \mathbf{A} - \mathbf{K}\mathbf{C} - \mathbf{M}_1\mathbf{C})^{-1}\mathbf{B} + \gamma^{-2}\mathbf{F}(s\mathbf{I} - \mathbf{A} - \mathbf{K}\mathbf{C} - \mathbf{M}_1\mathbf{C})^{-1}\mathbf{Y}_{12}\mathbf{C}_{2,P}^T\mathbf{C}_{2,P}\Delta^{-1}\mathbf{M}_2\mathbf{C} \\ &\quad \times (s\mathbf{I} - \mathbf{A} - \mathbf{K}\mathbf{C} - \mathbf{M}_1\mathbf{C})^{-1}\mathbf{B} - \mathbf{L}_2\Delta^{-1}\mathbf{M}_2\mathbf{C}(s\mathbf{I} - \mathbf{A} - \mathbf{K}\mathbf{C} - \mathbf{M}_1\mathbf{C})^{-1}\mathbf{B} \\ &= \mathbf{F}d_{11}\mathbf{B} - \mathbf{L}_2d_{21}\mathbf{B} \\ &= [\mathbf{F} \quad -\mathbf{L}_2] \times \begin{bmatrix} d_{11} & d_{12} \\ d_{21} & d_{22} \end{bmatrix} \times \begin{bmatrix} \mathbf{B} \\ \mathbf{0} \end{bmatrix} \\ &= [\mathbf{F} \quad -\mathbf{L}_2] \times \begin{bmatrix} s\mathbf{I} - \mathbf{A} - \mathbf{K}\mathbf{C} - \mathbf{M}_1\mathbf{C} & -\gamma^{-2}\mathbf{Y}_{12}\mathbf{C}_{2,P}^T\mathbf{C}_{2,P} \\ -\mathbf{M}_2\mathbf{C} & s\mathbf{I} - \mathbf{A} - \mathbf{B}\mathbf{F} - \gamma^{-2}\mathbf{Y}_{22}\mathbf{C}_{2,P}^T\mathbf{C}_{2,P} - \mathbf{B}\mathbf{L}_2 \end{bmatrix} \times \begin{bmatrix} \mathbf{B} \\ \mathbf{0} \end{bmatrix} \end{aligned}$$

From this recovery matrix, we can immediately write down the parameters listed in Theorem 4.6.

## APPENDIX F

### Proof of Theorem 4.7

Let  $\mathbf{P}$  be the unique matrix satisfying  $\mathbf{A}^T\mathbf{P} + \mathbf{P}\mathbf{A} + \mathbf{C}^T\mathbf{C} = \mathbf{C}_{2,P}^T\mathbf{C}_{2,P}$ , with  $\text{rank } \mathbf{C}_{2,P} = r$ , and further that  $(\mathbf{A}, \mathbf{B}, \mathbf{C}_{2,P}, \mathbf{0})$  is a minimum phase system (see Appendix E).

We claim that

$$\bar{\mathbf{P}} = \begin{bmatrix} \mathbf{P} & -\mathbf{P} \\ -\mathbf{P} & \mathbf{P} \end{bmatrix} \quad (\text{F.1})$$

is the solution to the quadratic matrix inequality associated with  $\Sigma_{10, S_1}$  given by (90). Indeed, by substituting this  $\bar{\mathbf{P}}$ ,  $\bar{\mathbf{F}}_\gamma(\bar{\mathbf{P}})$  becomes:

$$\bar{\mathbf{F}}_\gamma(\bar{\mathbf{P}}) = \begin{bmatrix} \mathbf{A}^T\mathbf{P} + \mathbf{P}\mathbf{A} + \mathbf{C}^T\mathbf{C} & -\mathbf{A}^T\mathbf{P} - \mathbf{P}\mathbf{A} - \mathbf{C}^T\mathbf{C} & \mathbf{0} \\ -\mathbf{A}^T\mathbf{P} - \mathbf{P}\mathbf{A} - \mathbf{C}^T\mathbf{C} & \mathbf{A}^T\mathbf{P} + \mathbf{P}\mathbf{A} + \mathbf{C}^T\mathbf{C} & \mathbf{0} \\ \mathbf{0} & \mathbf{0} & \mathbf{0} \end{bmatrix} = \begin{bmatrix} \mathbf{C}_{2,P}^T \\ -\mathbf{C}_{2,P}^T \\ \mathbf{0} \end{bmatrix} [\mathbf{C}_{2,P} - \mathbf{C}_{2,P} \quad \mathbf{0}] \quad (\text{F.2})$$

which is obviously positive semi-definite. Moreover, we have:

$$\text{rank } \bar{\mathbf{F}}_\gamma(\bar{\mathbf{P}}) = \text{rank } [\mathbf{C}_{2,P} \quad -\mathbf{C}_{2,P}] = \text{rank } \mathbf{C}_{2,P} = r \quad (\text{F.3})$$

and

$$\text{rank} \begin{bmatrix} s\mathbf{I} - \bar{\mathbf{A}} & \mathbf{B} \\ \bar{\mathbf{F}}_\gamma(\bar{\mathbf{P}}) & \mathbf{0} \end{bmatrix} = \text{rank} \begin{bmatrix} s\mathbf{I} - \mathbf{A} & \mathbf{0} & \mathbf{B} \\ \mathbf{0} & s\mathbf{I} - \mathbf{A}_F & \mathbf{0} \\ \mathbf{C}_{2,P} & -\mathbf{C}_{2,P} & \mathbf{0} \end{bmatrix} = \text{rank} [s\mathbf{I} - \mathbf{A}_F] + \text{rank} \begin{bmatrix} s\mathbf{I} - \mathbf{A} & \mathbf{B} \\ \mathbf{C}_{2,P} & \mathbf{0} \end{bmatrix} = 2n + r, \quad \forall s \in \bar{\mathbb{C}}^+ \quad (\text{F.4})$$

Since  $\mathbf{P}$  does not depend on  $\gamma$ , neither do  $\bar{\mathbf{P}}$ .

*Proof of Lemma 4.10*

First we choose  $\mathbf{L} = [\mathbf{L}_1 \ \mathbf{L}_2] = [\mathbf{F} \ \mathbf{0}]$  which satisfies (A.12), since then:

$$\left\| \begin{bmatrix} -\mathbf{C} & \mathbf{C} \end{bmatrix} \times \begin{bmatrix} s\mathbf{I} - \mathbf{A} - \mathbf{B}\mathbf{L}_1 & -\mathbf{B}\mathbf{L}_2 \\ \mathbf{0} & s\mathbf{I} - \mathbf{A} - \mathbf{B}\mathbf{F} \end{bmatrix}^{-1} \right\|_\infty \\ = \left\| -\mathbf{C}(s\mathbf{I} - \mathbf{A} - \mathbf{B}\mathbf{L}_1)^{-1} - \mathbf{C}(s\mathbf{I} - \mathbf{A} - \mathbf{B}\mathbf{L}_1)^{-1}\mathbf{B}\mathbf{L}_2(s\mathbf{I} - \mathbf{A} - \mathbf{B}\mathbf{F})^{-1} + \mathbf{C}(s\mathbf{I} - \mathbf{A} - \mathbf{B}\mathbf{F})^{-1} \right\|_\infty = 0 \quad (\text{F.5})$$

and

$$\Lambda \begin{bmatrix} s\mathbf{I} - \mathbf{A} - \mathbf{B}\mathbf{L}_1 & -\mathbf{B}\mathbf{L}_2 \\ \mathbf{0} & s\mathbf{I} - \mathbf{A} - \mathbf{B}\mathbf{F} \end{bmatrix} = \Lambda(\mathbf{A} + \mathbf{B}\mathbf{F}) \uplus \Lambda(\mathbf{A} + \mathbf{B}\mathbf{F}) \subset \mathbb{C}^- \quad (\text{F.6})$$

Hence  $\mathbf{L} = [\mathbf{F} \ \mathbf{0}]$  is an admissible choice.

We shall show that the gain  $\mathbf{M}$  can be chosen as:

$$\mathbf{M} = \begin{bmatrix} \mathbf{N} \\ \mathbf{0} \end{bmatrix} \quad (\text{F.7})$$

where  $\mathbf{N}$  satisfies  $\Lambda(\mathbf{A} + \mathbf{N}\mathbf{C}) \in \mathbb{C}^-$ , and hence also stabilizes  $\bar{\mathbf{A}} + \mathbf{M}\bar{\mathbf{C}}_1$ :

$$\Lambda(\bar{\mathbf{A}} + \mathbf{M}\bar{\mathbf{C}}_1) = \Lambda \begin{bmatrix} \mathbf{A} + \mathbf{N}\mathbf{C} & \mathbf{0} \\ \mathbf{0} & \mathbf{A} + \mathbf{B}\mathbf{F} \end{bmatrix} = \Lambda(\mathbf{A} + \mathbf{N}\mathbf{C}) \uplus \Lambda(\mathbf{A} + \mathbf{B}\mathbf{F}) \in \mathbb{C}^- \quad (\text{F.8})$$

For the left-hand side of the norm bound (A.13) we now have:

$$\left\| \bar{\mathbf{C}}_2(s\mathbf{I} - \bar{\mathbf{A}} - \bar{\mathbf{B}}\mathbf{L})^{-1}\bar{\mathbf{B}}\mathbf{L}(s\mathbf{I} - \bar{\mathbf{A}} - \mathbf{M}\bar{\mathbf{C}}_1)^{-1}\bar{\mathbf{E}} \right\|_\infty \\ = \left\| \mathbf{C}(s\mathbf{I} - \mathbf{A})^{-1}\mathbf{B}(\mathbf{I} - \mathbf{F}(s\mathbf{I} - \mathbf{A})^{-1}\mathbf{B})^{-1}[\mathbf{F} \ \mathbf{0}] \begin{bmatrix} s\mathbf{I} - \mathbf{A} - \mathbf{N}\mathbf{C} & \mathbf{0} \\ \mathbf{0} & s\mathbf{I} - \mathbf{A} - \mathbf{B}\mathbf{F} \end{bmatrix}^{-1} \begin{bmatrix} \mathbf{B} \\ \mathbf{0} \end{bmatrix} \right\|_\infty \\ = \left\| \mathbf{C}(s\mathbf{I} - \mathbf{A})^{-1}\mathbf{B}(\mathbf{I} - \mathbf{F}(s\mathbf{I} - \mathbf{A})^{-1}\mathbf{B})^{-1}\mathbf{F}(s\mathbf{I} - \mathbf{A} - \mathbf{N}\mathbf{C})^{-1}\mathbf{B} \right\|_\infty = \left\| \mathbf{G}_{\text{TFL}}(s)\mathbf{F}(s\mathbf{I} - \mathbf{A} - \mathbf{N}\mathbf{C})^{-1}\mathbf{B} \right\|_\infty \\ \leq \left\| \mathbf{G}_{\text{TFL}}(s)\mathbf{F} \right\|_\infty \left\| (s\mathbf{I} - \mathbf{A} - \mathbf{N}\mathbf{C})^{-1}\mathbf{B} \right\|_\infty \quad (\text{F.9})$$

Since  $(\mathbf{A}, \mathbf{B}, \mathbf{C}, \mathbf{0})$  is minimum phase,  $\left\| (s\mathbf{I} - \mathbf{A} - \mathbf{N}\mathbf{C})^{-1}\mathbf{B} \right\|_\infty$  can be made arbitrarily small, i.e. we can solve the following optimization problem:

$$\left\| (s\mathbf{I} - \mathbf{A} - \mathbf{N}\mathbf{C})^{-1}\mathbf{B} \right\|_\infty < \gamma (\left\| \mathbf{G}_{\text{TFL}}(\cdot)\mathbf{F} \right\|_\infty)^{-1} \quad (\text{F.10})$$

This is guaranteed to satisfy (A.13) by (F.9). The corresponding controller is then given by:

$$\mathbf{Q}(s) = [\mathbf{F} \ \mathbf{0}] \begin{bmatrix} s\mathbf{I} - \mathbf{A} - \mathbf{B}\mathbf{F} - \mathbf{N}\mathbf{C} & \mathbf{0} \\ \mathbf{0} & s\mathbf{I} - \mathbf{A} - \mathbf{B}\mathbf{F} \end{bmatrix}^{-1} \begin{bmatrix} \mathbf{N} \\ \mathbf{0} \end{bmatrix} = \mathbf{F}(s\mathbf{I} - \mathbf{A} - \mathbf{B}\mathbf{F} - \mathbf{N}\mathbf{C})^{-1}\mathbf{N} \quad (\text{F.11})$$

which is an  $n$ th-order controller.

#### REFERENCES

1. Athans, M., 'A tutorial on the LQG/LTR method', *Proc. American Control Conf.*, Seattle, WA, pp. 1289–1296 (1986).
2. Boyd, S. P., V. Balakrishnan, C. H. Barratt, N. M. Khraishi, X. Li, D. G. Meyer and S. A. Norman, 'A new CAD method and associated architectures for linear controllers', *IEEE Trans. Automatic Control*, **AC-33**, 268–283 (1988).
3. Doyle, J., K. Glover, P. Khargonekar and B. A. Francis, 'State-space solutions to standard  $\mathcal{H}_2$  and  $\mathcal{H}_\infty$  control problems', *IEEE Trans. Automatic Control*, **AC-34**, 831–847 (1989).
4. Doyle, J., and G. Stein, 'Robustness with observers', *IEEE Trans. Automatic Control*, **AC-24**, 607–611 (1979).

Page number 45 missing