

Technical University of Denmark



Reproducibility of a reaming test

Pilny, Lukas; Müller, Pavel; De Chiffre, Leonardo

Published in:

Proceedings of the 5th International Swedish Production Symposium

Publication date:

2012

[Link back to DTU Orbit](#)

Citation (APA):

Pilny, L., Müller, P., & De Chiffre, L. (2012). Reproducibility of a reaming test. In Proceedings of the 5th International Swedish Production Symposium (pp. 199-205)

DTU Library

Technical Information Center of Denmark

General rights

Copyright and moral rights for the publications made accessible in the public portal are retained by the authors and/or other copyright owners and it is a condition of accessing publications that users recognise and abide by the legal requirements associated with these rights.

- Users may download and print one copy of any publication from the public portal for the purpose of private study or research.
- You may not further distribute the material or use it for any profit-making activity or commercial gain
- You may freely distribute the URL identifying the publication in the public portal

If you believe that this document breaches copyright please contact us providing details, and we will remove access to the work immediately and investigate your claim.

Reproducibility of a reaming test

L. Pilný, P. Müller, L. De Chiffre
Technical University of Denmark,
Department of Mechanical Engineering, Kgs. Lyngby, Denmark
lupi@mek.dtu.dk

ABSTRACT

The reproducibility of a reaming test was analysed to document its applicability as a performance test for cutting fluids. Reaming tests were carried out on a drilling machine using HSS reamers. Workpiece material was an austenitic stainless steel, machined using $4.75 \text{ m}\cdot\text{min}^{-1}$ cutting speed and $0.3 \text{ mm}\cdot\text{rev}^{-1}$ feed. A mineral straight oil and a water-based lubricant at two different oil concentrations were compared with respect to hole quality, evaluated in terms of surface finish (conventional average roughness parameter R_a and roughness profiles), and hole geometry (hole diameter and roundness). Process reproducibility was assessed as the ability of different operators to ensure a consistent rating of individual lubricants. Absolute average values as well as experimental standard deviations of the evaluation parameters were calculated, and uncertainty budgeting was performed. Results document a built-up edge occurrence hindering a robust evaluation of cutting fluid performance, if the data evaluation is based on surface finish only. Measurements of hole geometry provide documentation to recognize systematic error distorting the performance test.

Keywords: Cutting fluid test, reaming, process reproducibility, test uncertainty, surface finish, hole geometry, built-up edge.

1. INTRODUCTION

An application of cutting fluids in machining operations is well known to provide greater tool life, reduction of cutting forces, improved surface characteristics and geometrical accuracy, thus resulting in improved process efficiency. This is due to cooling and lubrication properties of the cutting fluid and their interaction [1, 2].

There is no single test method of cutting fluid efficiency embracing all machining operations. Selection of an appropriate cutting fluid has to be based on testing under practical operating conditions but keeping all influence parameters under close laboratory control [3]. The difficulty of identifying the best cutting fluid, especially when several different machining methods were employed, was experimentally documented in [4]. Prioritization of the output measures and specification of the relative importance of each machining operation was suggested.

An extensive research on the effects of cutting fluids in drilling operations was carried out in [5]. Results indicated no significant effect between two water-soluble oils (2 and 8% concentrations respectively). On the contrary, significantly larger average surface finish and its variation when cutting dry compared to the use of cutting fluid were observed.

In [6], a reaming test was proposed as a method for cutting fluid lubrication efficiency assessment, based on previous researches related to the development of performance tests for cutting fluids at the Technical

University of Denmark (DTU) [3,6-12]. From an operation point of view, requirement on lubricating efficiency of cutting fluid is pronounced for reaming operation due to low speeds and feed rates generally utilized, allowing built-up edge (BUE) occurrence. From a test point of view, reaming test provides easier surface quality evaluation compared to e.g. tapping, proposed as standardized test procedure in [13].

This study is related to the research at DTU concerning the development of performance tests for cutting fluids, in particular those involving measurements of product quality [3,6,7]. This paper aims to document and provide more robust test procedure for comparison of lubricants.

2. EXPERIMENTAL CONDITIONS

All the reaming tests were carried out on a 3.7 kW Modig vertical drilling machine. Three high speed steel 6-flute left hand helix (-7°) machine reamers $\varnothing 10.8 \text{ H7 DIN 212 form D, HSS-E}$ were used for the tests. The reamers were clamped in a floating holder SK30 x MK3 Gewefa, which enables to accurately align with the pre-manufactured hole (i.e. pilot hole).

Specimens were austenitic steel AISI 316L. An investigation using the same specimens (material and dimensions) was performed in [10-12], to investigate the efficiency of cutting fluids in multiple machining operations and to document a process capability using metrological approach, respectively. The workpiece material characteristics are summarized in Table 1. Such material is difficult to machine owing to

its ductility, low thermal conductivity, and high strain hardening. Such properties cause ease of work hardening if machining parameters are not chosen correctly.

Workpiece material		AISI 316 L Stainless steel	
Vickers Hardness		258.1 HV20	
Composition analysis			
Element	Mass in %	Element	Mass in %
C	0.016	Cr	17.31
Si	0.39	Mo	2.11
Mn	1.4	S	0.026
P	0.027	N	0.052
Ni	11.21		

Table 1: Workpiece material characteristics [11].

The test workpieces were rings of diameter 29 and height of 30 mm with pre-manufactured holes of 10.3 mm in diameter by reaming. The dimensional characteristics and surface roughness specifications of the workpieces were previously specified in [10]. Workpieces were clamped in a dedicated holder so that the workpieces were fully immersed in the cutting fluid.

Three cutting fluids, selected in accordance with [7], were used throughout the test (see Table 2). The workpieces were fully immersed in the cutting fluid during the cutting. The order of the application of each lubricant will be discussed in section 5 – Experimental plan.

Code	Description	Oil concentration in %
WB1	Amine-free water-based cooling lubricant	1
WB10	Amine-free water-based cooling lubricant	10
MO	Mineral straight oil	100

Table 2: Summary of tested cutting fluids.

Cutting conditions based on previous experience in reaming austenitic stainless steel with HSS reamers were selected. In particular, cutting speed of $4.75 \text{ m}\cdot\text{min}^{-1}$ and feed per revolution of 0.3 mm were selected.

3. MEASUREMENT PROCEDURES

3.1 Surface roughness measurement

Surface topography of the reamed holes was characterized in terms of conventional surface roughness parameters R_a , defined in ISO 4287 [14]. Measurements were carried out using a stylus roughness tester, Surtronic 4+, equipped with a skid pick-up and a $2 \mu\text{m}$ radius tip according to ISO 3274:1975 [15]. The instrument was calibrated before the actual measurement series using an optical flat, to determine the background noise and an

ISO 5436 type C roughness standard, to determine the repeatability of the measurement.

Surface profiles were recorded at three different positions on the reamed specimens, approx. equally distributed around the hole circumference, at a distance approx. 5 mm from the top surface (see Fig. 1). Then the specimens were turned and measured, following the same strategy, at the bottom at a distance approx. 5 mm from the bottom face of the workpiece. An evaluation length $l_n = 4 \text{ mm}$, low-pass $\lambda_s = 0 \mu\text{m}$ and high-pass $\lambda_c = 0.8 \text{ mm}$ profile filtering, according to ISO 3274:1996 [16], were applied.

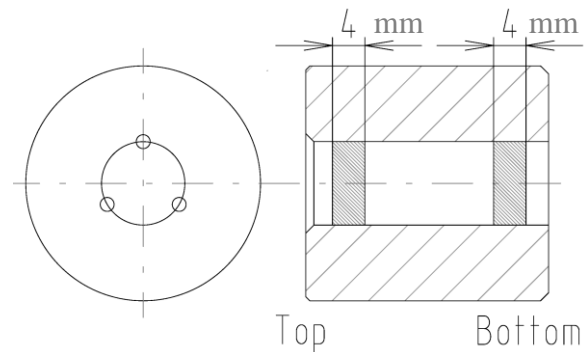

Fig. 1: Indication of the measured positions for surface roughness measurements.

3.2 Hole geometry measurement

Geometrical characteristics of the workpieces – diameter and roundness – were measured using a tactile coordinate measuring machine (CMM).

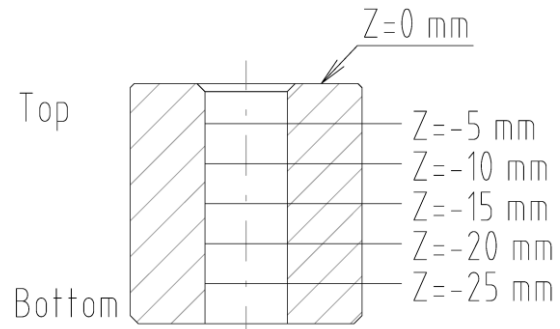

Fig. 2: Indication of the measured vertical positions for hole diameter and roundness measurements.

The reamed holes were measured at five levels determined along the workpiece height (see Fig. 2). 12 points equally distributed around the hole circumference were taken at each level of the hole. Measuring strategy with five levels and 12 points was applied to better understand the effect of the cutting fluids on selected parameters, which could not be achieved if less levels or number of points were chosen. The selection of the measuring strategy (12 points, five levels) was based on preliminary measurements carried out on a master piece. Since

the machine was checked for accuracy prior measurement by measuring a reference ring (standard uncertainty was estimated to be $0.1 \mu\text{m}$) and uncertainty due to measuring repeatability was assessed on a master piece (standard uncertainty was estimated to be $1.6 \mu\text{m}$), workpieces were measured only once.

4. UNCERTAINTY ASSESSMENT FOR SURFACE ROUGHNESS

Uncertainty for surface roughness measurement was calculated according to the GUM [14] as follows:

$$U_{ROUGH}(Ra) = k \cdot \sqrt{u_{INS}^2 + u_S^2} \quad (1)$$

where

- $U_{ROUGH}(Ra)$ = expanded uncertainty of surface roughness measurements on reamed holes for Ra surface roughness parameter;
- k = coverage factor ($k=2$ for a confidence level of 95%);
- u_{INS} = standard uncertainty of the instrument, taking into account uncertainty from calibration of the instrument using a roughness standard, repeatability of the instrument and uncertainty caused due to the background noise;
- u_S = standard uncertainty caused by variations in the roughness of the specimen in different locations, considering different workpieces from the same batch and different operators; $u_S = STD_S/\sqrt{n}$, where n is the number of measurements carried out on all the specimens for one cutting fluid with standard deviation STD_S .

Estimated expanded measurement uncertainty due to the instrument calibration was $0.014 \mu\text{m}$.

5. EXPERIMENTAL PLAN

Cutting conditions specified in section 2 were applied by three operators, performing the test in different days. The influence of the operator on defined evaluation parameters (measurands) in terms of surface roughness and reamed hole geometry (diameter and roundness) was investigated. Each operator randomly chosen 18 specimens from a production batch, and assigned each six specimens to be reamed using different cutting fluids. Each operator used the three cutting fluids in the same following order: WB1-WB10-M.O. The tool and the reservoir were cleaned during each cutting fluid change. A new reamer was used by each operator performing the test in different days. The reamers were measured before the tests to control the actual diameter of the hole and reaming of five workpieces was used as run-in preceding the actual test.

6. RESULTS AND DISCUSSION

Different lubrication efficiency of the cutting fluids could already be seen during the cutting, where different types of chips were observed. Cutting with

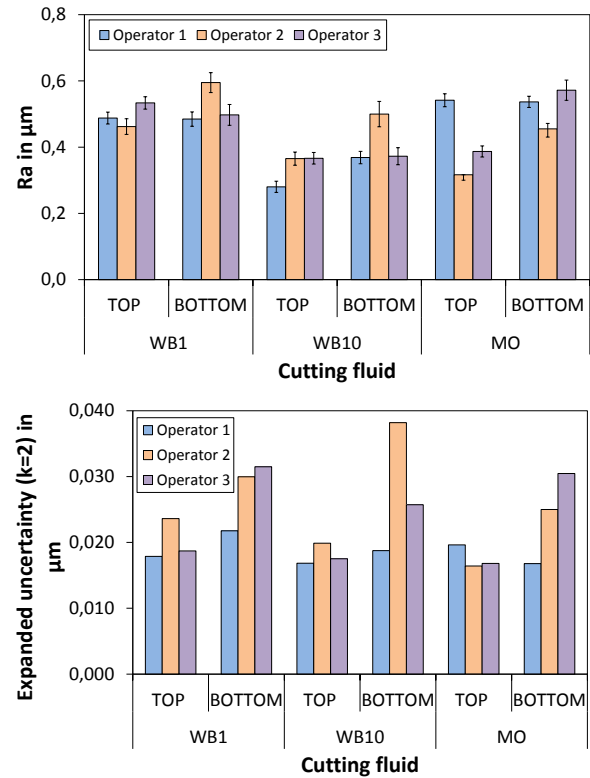

Fig. 3: Results of the average surface roughness parameter Ra (top), measured by three operators at the top and at the bottom of reamed holes for each tested cutting fluid, and associated expanded uncertainties (bottom).

water-based cutting fluids (WB1 and WB10) provided lamellar chips having very short length for WB1 and slightly longer for WB10. While the process using pure mineral oil (MO) provided long flow chips. Different chip formation mechanisms were caused by different lubricating conditions where better lubricant causes greater restriction of contact area between the tool rake face and workpiece being cut off in form of chip. Smaller contact area results in smaller friction, less inclination to the occurrence of BUE, smaller cutting forces required and smaller degree of deformation of the chip (e.g. flow type chips).

6.1 Surface roughness measurement

6.1.1 Ra parameter

Results of the surface roughness parameter Ra (see Fig. 3 top) indicate that generally this parameter is slightly smaller for measurements at the top of the hole and bigger at the bottom of the hole. However, the difference is small. Comparing different cutting fluids, one can observe smaller Ra values by approx. $0.1 \mu\text{m}$ when cutting using WB10. However, the difference is not substantial compared with the other cutting fluids. Taking into account stochastic nature of surface roughness [3], such a variation will not provide robust information if one lubricant is better than the other. All the three operators performed the

cutting with a moderate reproducibility (considering the average values only). The results of measurement uncertainties, calculated at a confidence level of 95% ($k=2$), are shown in Fig. 3 bottom. Measurement uncertainties obtained for measurements at the top of the bores are of approx. the same magnitude for all tested cutting fluids (cca. $0.020 \mu\text{m}$) with small variability. On the contrary, uncertainties for measurements at the bottom are of bigger magnitude with great variability, directly indicating instability of the process. The uncertainties calculated for measurements at the top and the bottom of the hole are in the similar range for all three cutting fluids.

Table 3 presents results of a COV parameter. This parameter represents a variation (standard deviation) of measurement with a given cutting fluid, expressed in percentage of the average test result. In [3] it is discussed that generally reaming tests, particularly tests involving cutting of the stainless steel, yield the COV parameter in the range 5-60 % when using water-based and 5-30 % when using oil as a lubricant. In this study, the COV parameter was also calculated in this range.

6.1.2 Surface roughness profiles

Surface roughness profiles measured in the reamed holes are generally reproducible for all three cutting fluids, considering nine randomly selected workpieces from the batch, as well as different operators.

Oper. no.	WB1		WB10		MO	
	Top	Bottom	Top	Bottom	Top	Bottom
1	20	31	30	30	16	23
2	25	33	31	43	19	20
3	15	26	26	29	18	24

Table 3: Results of the coefficient of variation (COV) for surface roughness parameter Ra. The COV is expressed in %.

However, higher reproducibility of the profiles is achieved for measurements at the top of the holes. At this point it is difficult to recognize the reasons for these differences, but it is discussed in the following section. Fig. 4 presents an example of the profiles taken at the top and at the bottom of three different reamed holes for each of all the three cutting fluids. First, one can observe that a clear difference between the appearance of the profiles at the top and at the bottom exists. Taking into account the parameter Ra (arithmetic mean), the values of this parameter for each of the fluid at both the top and the bottom are similar, which in many cases may lead to wrong interpretations of the results. However, good reproducibility (similar appearance) of the profiles can be recognized for measurements at the top and at the bottom of the hole.

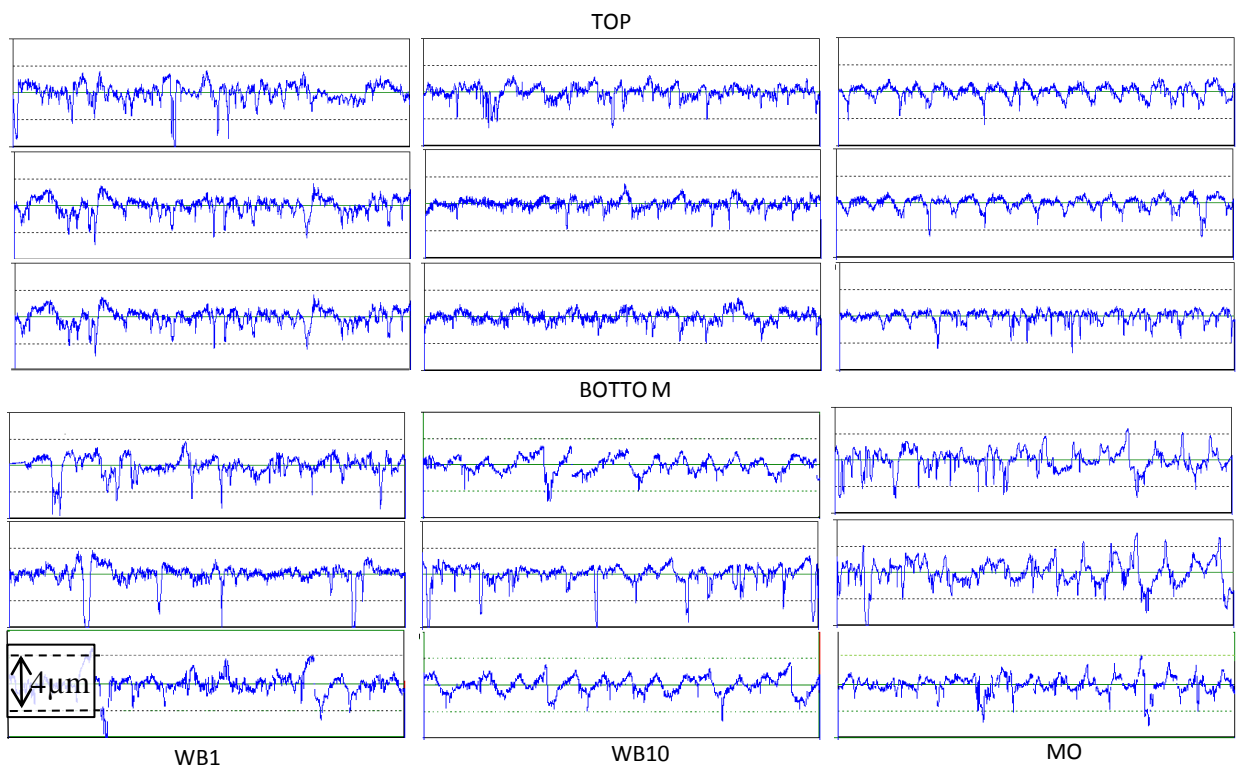

Fig. 4: Nature and reproducibility of surface roughness profiles of reamed holes with different cutting fluids: WB1 (left), WB10 (middle) and MO (right). Length of all the profiles is 4 mm, vertical scale is shown in the left bottom figure.

It was shown in [7] that average surface roughness parameter Ra may exhibits loss of information, and it is always recommended to take the original profiles into account.

At this stage of the investigation, it is not possible to provide consistent ranting of the cutting fluids because the results of the average surface roughness parameter Ra are of approx. the same magnitude, even though having different surface roughness profile appearance. Therefore, further investigation on the quality of the reamed holes in terms of measurements of hole diameter and hole roundness are carried out. As described in earlier work [6,10], the two measurands belong to the typical performance criteria in reaming.

6.2 Hole geometry measurements

6.2.1 Diameter

Fig. 5 shows diameter of reamed holes measured at five different levels along specimens height, clearly showing its increase in the direction of feed of the tool, i.e. smaller diameter at the top of the hole where the reamer starts to cut the workpiece and bigger towards the bottom. This behavior is hardly distinguishable when using cutting fluid WB1 whereas more pronounced for the other cutting fluids WB10 and MO. This is attributed to be likely due to BUE occurrence during the process as discussed in the following.

Reproducibility of reamed hole diameter by three different operators is shown in Fig. 6, taking into account the two most distinct measured levels of the workpieces (top and bottom). The graph shows high reproducibility within approx. 10 μm of the hole diameter measured at the top level whereas poor reproducibility of approx. 50 μm measured at the bottom level. This confirms the assertion of BUE occurrence since a substantial amount of BUE would naturally be removed by the first contact between the tool and workpiece, reflected by more regular and repeatable geometry of reamed bore – represented by the top measured level in Fig. 5 and Fig. 6. The greater scatter of reamed diameter measured at the bottom level of the specimen reflects a stochastic nature of BUE and thus poor reproducibility.

6.2.2 Roundness

Roundness of reamed holes measured at five different levels along workpieces height for the three tested cutting fluids by single operator is depicted in Fig. 7. The measured data shows 2 times greater scatter of reamed holes roundness along the tool feed direction when using WB1 cutting fluid compared to WB10 and MO. This behavior is assumed to be due to faster reoccurrence of BUE (creation and break off) when cutting fluid having worse lubrication utilized, resulting in cutting with changing cutting edge geometry and thus poor bore roundness. With better lubrication the BUE occurrence is slower, providing

more stable cutting edge geometry and thus better roundness (2D bore geometry).

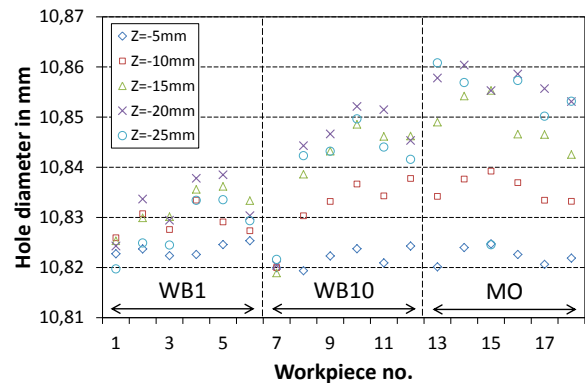

Fig. 5: Reamed hole diameter measured at five different levels along specimen height for the three tested cutting fluids.

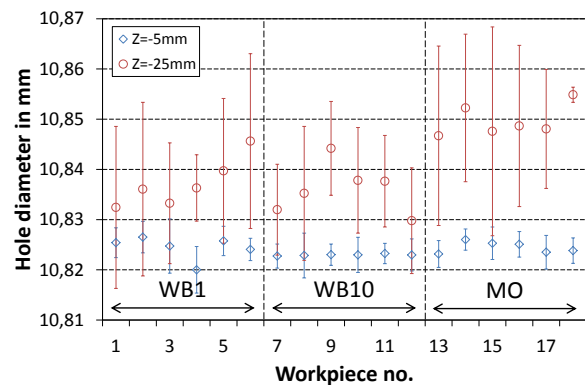

Fig. 6: Reproducibility of the reamed hole diameter measured at two different levels along specimen height (top Z=-5 mm and bottom Z=-25 mm) for the three tested cutting fluids. Error bars represent the experimental standard deviation from three operators.

Roundness reproducibility of reamed holes based on three different operators is depicted at the top and bottom measured levels in Fig. 8. The top level exhibits smaller variability over number of reamed holes utilizing different cutting fluids, mostly reflecting variation in the remaining amount of BUE after its break off due to the first contact of the tool with the workpiece. The bottom level shows bigger roundness error owing to faster reoccurrence of BUE and great variability when using cutting fluid WB1, directly reflecting stochastic nature of BUE. Cutting fluids having better lubrication properties, WB10 and MO respectively, exhibit decrease in roundness and its variability. This is due to more constant cutting edge geometry during slower BUE accumulation.

It can be observed from Figs. 5-8 that there is an opposing cross correlation of reamed holes diameter (increasing trend) and holes roundness (decreasing trend), depicted in Fig. 9, for the three tested cutting fluids and three operators. This is directly showing the

effect of BUE formation on reamed hole geometry, while the effect on the test reproducibility was previously discussed. To confirm our hypothesis about the occurrence of BUE, the tools were checked under the microscope and Fig. 10 shows its presence on the cutting edge.

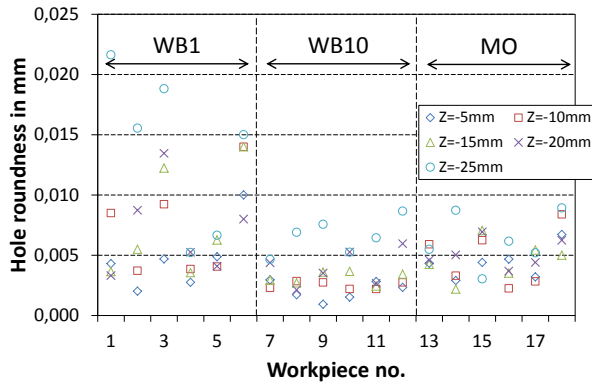

Fig. 7: Roundness of reamed holes measured at five different levels along specimen height for the three tested cutting fluids.

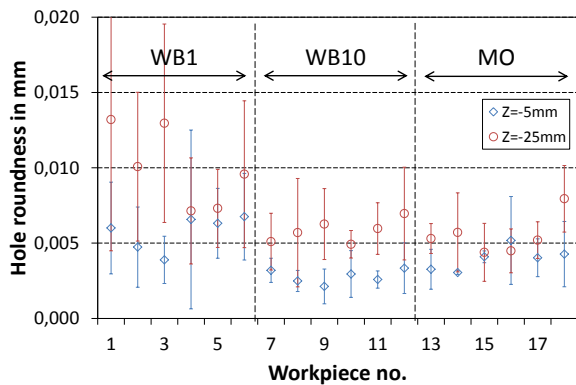

Fig. 8: Reproducibility of the reamed hole roundness measured at two different levels along specimen height (top Z=-5 mm and bottom Z=-25 mm) for the three tested cutting fluids. Error bars represent the experimental standard deviation from three operators.

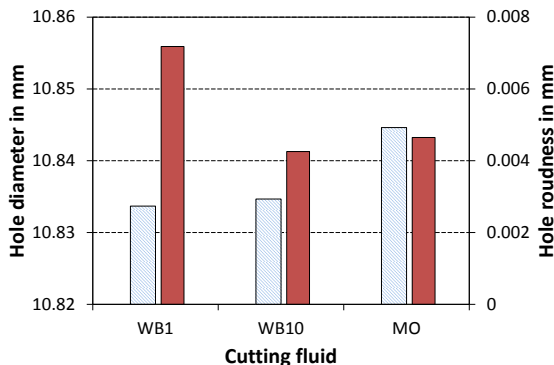

Fig. 9: Average diameter (light blue hatched) and roundness (dark red) of reamed holes for the three tested cutting fluids by three operators.

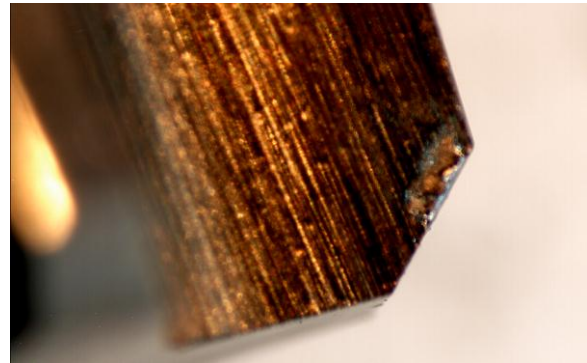

Fig. 10: Occurrence of BUE on the tool's cutting edge.

7. CONCLUSION AND OUTLOOK

An investigation on a reaming test was carried out to document test reproducibility using a metrological approach. Tests were performed on a drilling machine using HSS reamers. Workpiece material was an austenitic stainless steel, machined by different operators using fixed cutting conditions. Three different lubricants were compared, using surface roughness and hole geometry as performance criteria. The process reproducibility was assessed as the ability of different operators to ensure a consistent rating of individual lubricants. Based on the results, the following conclusions are drawn:

- Reaming test is well reproducible by different operators, although consistent rating of individual lubricants can be hindered by systematic error (i.e. BUE).
- The reaming process is affected by BUE formation reoccurring on the cutting edge with periodical creation and break off.
- This is reflected in tapered shape, deteriorated roundness, as well as different roughness at top and bottom in the reamed holes.
- Uncertainty of surface finish measurements at the top and the bottom of reamed holes indicates instability of the process.
- BUE can remain on the tool after the test and affect following tests.
- Water-based cutting fluid WB1 resulted in small variation in bore diameter over the bore height while having bigger roundness error. This is due to poor lubrication of the cutting fluid, resulting in quickly changing effective cutting edge geometry owing to BUE formation.
- On the contrary, use of cutting fluids with better lubrication properties, WB10 and MO respectively, resulted in tapered bore with better roundness achieved. This behaviour is caused by slowly increasing effective cutting edge geometry during the process due to BUE formation.
- The test has shown that if cutting fluid performance test is only based on quantitative comparison of the Ra roughness parameter, hidden influences as BUE may lead to wrong conclusions. Therefore an additional analysis is

necessary. E.g. qualitative evaluation of roughness profiles, dimensional measurements, etc.

Measurement of cutting forces (cutting thrust and torque) is expected to add relevant information of the test. Changing the order of lubricants tested or replacing the cutting tool by a new one for each tested cutting fluid should also be considered to provide more robust evaluation.

REFERENCES

- [1] Shaw, M.C (2005). *Metal cutting principles*, Second edition, Oxford University Press, New York (USA).
- [2] De Chiffre, L. (1988). Function of cutting fluids in machining. *Lubrication Engineering*, **Vol. 44**, pp. 514-518.
- [3] De Chiffre, L. and W. Belluco (2000). Comparison of methods for cutting fluid performance testing, *Annals of CIRP*, **Vol. 49/1**, pp.57-60.
- [4] Axinte, D, Axinte, M. and J. D. T. Tannock (2003). A multicriteria model for cutting fluid evaluation, In: *Proceedings of the Institution of Mechanical Engineers, Part B: Journal of Engineering Manufacture*, **Vol. 217**, pp. 1341-1353. DOI: 10.1243/095440503322617117.
- [5] Haan, D. M., Batzer, S. A., Olson, W. W. and J. Sutherland (1997). An experimental study of cutting fluid effects in drilling, *Journal of Material Processing Technology* **71**, pp. 305-313.
- [6] De Chiffre, L., Lassen, S., Pedersen, K.B. and S. Skade (1994). A Reaming Test for Cutting Fluid Evaluation. *Journal of Synthetic Lubrication*, **Vol. 11**, 17–34.
- [7] Müller, P. and L. De Chiffre (2011). Reproducibility of surface roughness in reaming. In: *Proceedings of The 4th International Swedish Production Symposium (SPS11)*, pp. 518-524.
- [8] De Chiffre, L. (1977). Mechanics of metal cutting and cutting fluid action, *International Journal of Machine Tool Design and Research*, **Vol. 17/4**, pp. 225-234.
- [9] De Chiffre, L., Zeng, Z. and Belluco, W. (2001). An investigation of reaming test parameters used for cutting fluid evaluations, *Lubrication Engineering*, **Vol.57**, pp. 24-28.
- [10] Belluco, W. (2000). Performance testing of cutting fluids. *Ph.D. thesis*, Technical University of Denmark.
- [11] De Chiffre, L., Tosello, G., Piska, M. and P. Müller (2009). Investigation on Capability of Reaming Process using Minimal Quantity Lubrication, *CIRP Journal of Manufacturing Science and Technology*, **Vol. 2/1**, pp. 47-54.
- [12] Müller, P., Genta, G., Barbato, G., De Chiffre, L. and R. Levi (in press). Reaming process improvement and control: an application of statistical engineering. *CIRP Journal of Manufacturing Science and Technology*.
- [13] Lorenz, G. (1985). Reliable cutting fluid rating, *Annals of CIRP*, **Vol. 34/1**, pp. 95-99.
- [14] ISO 4287:1997 Geometrical Product Specifications (GPS) – Surface Texture: Profile Method – Terms, Definitions and Surface Texture Parameters.
- [15] ISO 3274:1975 Instruments for the Measurement of Surface Roughness by the Profile Method – Contact (stylus) Instruments of consecutive Profile Transformation – Contact Profile Meters, System M.
- [16] ISO 3274:1996 Geometrical Product Specifications (GPS) – Surface Texture: Profile Method – Nominal Characteristics of Contact (stylus) Instruments.
- [17] ISO/IEC Guide 98-3:2008 – Uncertainty of measurement -- Part 3: Guide to the expression of uncertainty in measurement (GUM:1995).