

Technical University of Denmark



Active power control with undead-band voltage & frequency droop applied to a meshed DC grid test system

Vrana, Til Kristian; Zeni, Lorenzo; Fosso, Olav Bjarte

Published in:
2012 IEEE International Energy Conference and Exhibition

Publication date:
2012

[Link back to DTU Orbit](#)

Citation (APA):
Vrana, T. K., Zeni, L., & Fosso, O. B. (2012). Active power control with undead-band voltage & frequency droop applied to a meshed DC grid test system. In 2012 IEEE International Energy Conference and Exhibition (pp. 612-616). IEEE.

DTU Library
Technical Information Center of Denmark

General rights

Copyright and moral rights for the publications made accessible in the public portal are retained by the authors and/or other copyright owners and it is a condition of accessing publications that users recognise and abide by the legal requirements associated with these rights.

- Users may download and print one copy of any publication from the public portal for the purpose of private study or research.
- You may not further distribute the material or use it for any profit-making activity or commercial gain
- You may freely distribute the URL identifying the publication in the public portal

If you believe that this document breaches copyright please contact us providing details, and we will remove access to the work immediately and investigate your claim.

ACTIVE POWER CONTROL WITH UNDEAD-BAND VOLTAGE & FREQUENCY DROOP APPLIED TO A MESHED DC GRID TEST SYSTEM

Til Kristian Vrana^a, Lorenzo Zeni^b, Olav Bjarte Fosso^a

^aNorwegian University of Science and Technology, Trondheim, Norway

^bDTU Wind Energy and Vestas Wind Systems, Denmark

ABSTRACT

A new method for controlling active power in HVDC grids has been tested on the meshed CIGRE B4 DC grid test system. The control strategy is based on the recently proposed undead-band droop control, which combines DC voltage and AC frequency droop. It provides sufficient room for optimisation for both normal and disturbed operation. Its main features are flexibility, reliability due to distributed control, easy expandability of the system and minimisation of communication needs. The control technique has been tested and its effectiveness has been verified to demonstrate its suitability for application in future meshed HVDC grids.

Index Terms— HVDC, Power Converter, Active Power Control, Droop Control, Meshed DC Grid.

1. INTRODUCTION

Meshed HVDC grids have not been built to date, but the topic is ever more relevant for the academic, industrial and political communities, as a consequence of sharp technological improvements and ambitious targets for renewable energy integration and interconnection between distant, often asynchronous, grids.

Particularly, the North Sea appears like a very fertile area for the implementation of first meshed HVDC grids [1], with several offshore wind farms that are being built or planned. As the installations get farther from shore and their number increases, the HVDC multi-terminal configuration looks as the most attractive option, as opposed to many point-to-point connections, since it would be optimal from both a technical and economical perspective [2][3][4][5]. An agreement on the construction of the so called North Sea Super Grid has already been reached [6] and research on the topic has been initiated – e.g. [5][7][8].

One of the technological issues to be addressed if such multi-terminal DC grid is to be built is certainly its control and a number of investigations, not limited to [9][10][11], have touched upon the subject.

The aim of a controller for large meshed HVDC grids should be the provision of a number of important features, such as reliability, distributed balancing control, robustness, flexibility, contribution to AC frequency control, satisfying dynamic performance and stability, and adaptability to many converter manufacturers. A crucial aspect is the fact that future meshed DC grids will most likely be the result of a progressive expansion of the system, rather than a development planned a priori.

The control techniques proposed so far bring about pros and cons and their effectiveness usually depends on the specific application. An integration of the features of the diverse concepts has been realised in [11], where a combined DC voltage and AC frequency undead-band droop has been tested on a small three-terminal DC grid.

Next step in the research is the demonstration of the validity of the approach on larger networks, including nodes with different nature, such as loads and uncontrolled power sources. Hence, the undead-band droop control is here applied to a larger network, the CIGRE B4 DC grid test system, demonstrating its efficiency in systems with more relevant size and illustrating how the strategy can be easily adapted to nodes with different characteristics.

This article is organised as follows. Section 2 recalls the basic operational principles of undead-band droop control, while Section 3 introduces the utilised test system. The simulation results are presented in Section 4, followed by outlook and conclusions in Section 5.

2. UNDEAD-BAND DROOP CONTROL

The control strategy utilised in this work consists of a combined DC voltage and AC frequency droop control, provided with a so called “undead-band”. The approach is described in [11] and only its basic features are recalled here.

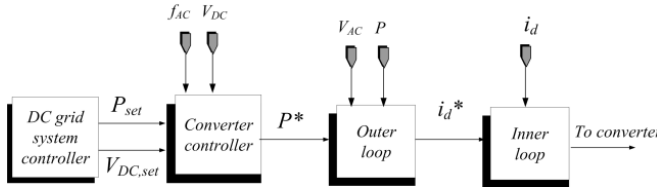

Figure 1: Overall block diagram for undead-band control

In Figure 1 the generic structure of a single VSC control is depicted. The power and DC voltage set-points are received from a central controller as it happens for other control methods. The other inputs are solely coming from local measurements and therefore avoid any need for fast communication between converters to build the converter power reference.

This research mainly regards the converter controller block in Figure 1, where the undead-band droop control is located. The outer loop block is implemented whereas the fast inner current control is a standard block from DIgSILENT Power Factory. The DC grid system controller is not subject to this research.

The combination of DC voltage and AC frequency droop control is implemented with the use of an undead-band, where undead means that the droop action is weaker when AC frequency and DC voltage do not deviate substantially from their setpoints, but is still active in order to maintain an efficient and stable control of the grid.

When the measured quantities exit such undead-band, the steady-state control gain is increased, leading to a prompt system response.

The control principles are well summarised by Figure 2 and Figure 3, which refer to P/V_{DC} and P/f_{AC} steady-state curves respectively. These curves are to illustrate the principle, but do not reflect the control parameters used in the simulations.

The steady-state control gains (the droop constant is the inverse of the gain) are $K_{v,1}$ and $K_{v,2}$ for DC voltage droop and $K_{f,1}$ and $K_{f,2}$ for AC voltage droop, where subscript 1 refers to undisturbed operation – within the undead-band – and subscript 2 to disturbed operation.

Other parameters that can be set, according to control objectives and physical limitations, are the limits for power injection, DC voltage and AC frequency.

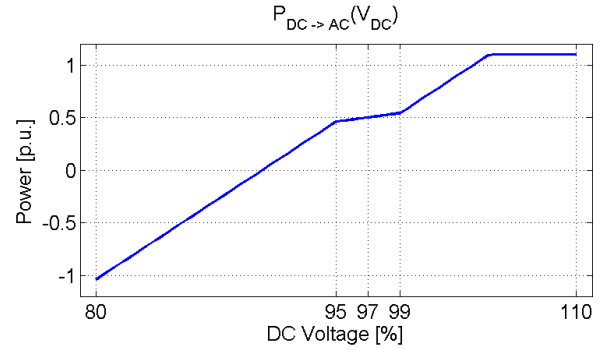

Figure 2: Power – DC voltage relation

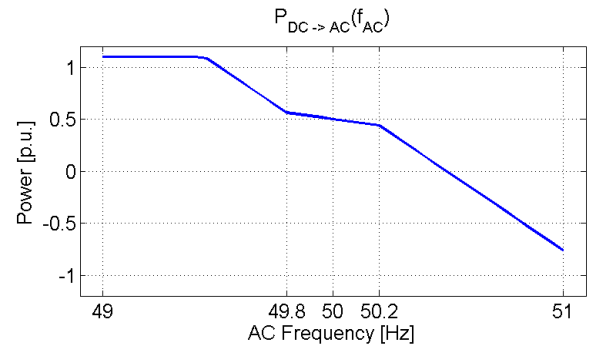

Figure 3: Power - frequency relation

One of the most interesting features of the proposed strategy is the fact that it can in practice reproduce almost any of the control techniques suggested and used so far – e.g. dead-band, master-slave, voltage margin, droop control, etc. This indicates good flexibility of the control structure, where the parameters of every converter can be optimised according to a specific grid’s needs.

It is furthermore apparent that efficient decoupling between normal and disturbed operation can be achieved with the proposed control scheme. The control parameters can be optimised for both operating conditions.

Moreover, the expansion to a multi-terminal system, as demonstrated in this article, can easily be done and several kinds of nodes can be accommodated without substantially modifying the control structure.

3. CIGRE DC GRID TEST SYSTEM

To be able to validate the developed control strategy with undead-band, a meshed DC grid test system was being designed by the authors. At the same time, the first author of this article is also involved in CIGRE working group B4-58, which decided to develop a DC grid test system, to be used for a variety of studies done by the CIGRE B4 working groups.

These efforts have been merged together and the resulting test system has been designed not only for the study presented in this article, but also for all CIGRE B4 working groups on DC grids. The authors would like to

thank all CIGRE B4 members that have contributed to the DC grid test system.

The goal of designing the DC grid test system was to create a system which would be as simple as possible, but still complex enough to grasp the most relevant phenomena of DC grids. Even though the test system design is not completely finished yet, the basic layout and some details

have been decided yet, so the system could be applied in this study. The grid layout is shown in Figure 4.

The system consists of 3 zones. Zone A is producing a power surplus of 1500MW, Zone B is consuming 3900MW more than it is producing, and the third zone is offshore. The offshore zone is split into 4 parts, of which 3 are wind farms with a total generation of 2500MW and 1 is an offshore load (100MW).

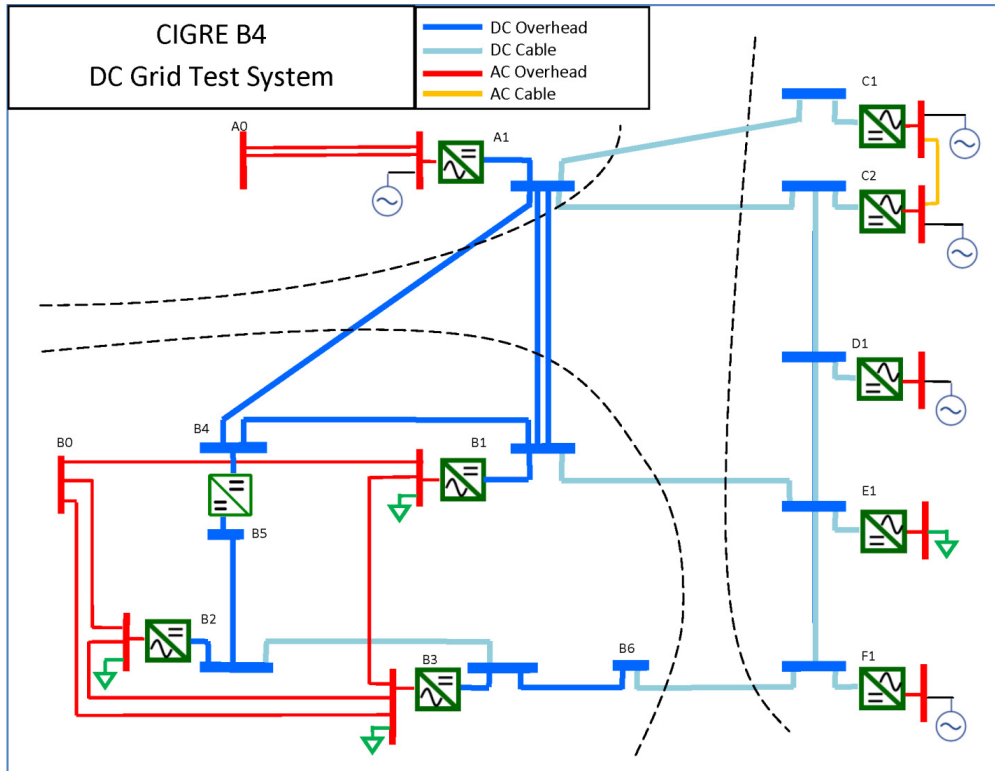

Figure 4: CIGRE B4 DC grid test system

4. SIMULATION RESULTS

The proposed control method has been implemented and tested on the CIGRE B4 DC grid test system in the power system simulation tool DlgSILENT Power Factory, in order to achieve a validation of the control principles and the functionality of the undead-band controller.

The undead-band control has been inserted for all four onshore HVDC converters (bus A1, B1, B2 and B3). All four converters are given different control parameters to display the flexibility of the undead-band control approach.

- Converter A1 is controlling the DC voltage under normal operation conditions with a high control gain (low droop value). It does not regard AC frequency.

- Converter B1 is controlled with the proposed undead-band control strategy. It is assisting power balancing control under normal operation conditions with a smaller control gain, but has a high gain outside the undead-band. B1 also regards AC frequency to support frequency stability in Zone B.
- Converter B2 is controlled with zero control gains, and therefore behaves like a constant power source.
- Converter B3 uses regular droop control for DC voltage and AC frequency.

These four completely different control behaviours of the four converters could be achieved without making any changes to the control blocks of the undead-band controller. Simply the selection of the control parameters defines the

control behaviour. The most important control parameters (in pu.) are summarised in Table 1.

Converter	Parameter	Normal	Disturbed
A1	V_{DC}	$K_{v,1} = 8$	$K_{v,2} = 0$
	f_{AC}	$K_{f,1} = 0$	$K_{f,2} = 0$
B1	V_{DC}	$K_{v,1} = 2$	$K_{v,2} = 25$
	f_{AC}	$K_{f,1} = -4$	$K_{f,2} = -4$
B2	V_{DC}	$K_{v,1} = 0$	$K_{v,2} = 0$
	f_{AC}	$K_{f,1} = 0$	$K_{f,2} = 0$
B3	V_{DC}	$K_{v,1} = 2$	$K_{v,2} = 2$
	f_{AC}	$K_{f,1} = -2$	$K_{f,2} = -2$

Table 1: Converter control parameters

The simulated case is an outage of bus E1 (100MW load) and one second later an outage of bus D1 (1000MW generation). This is a significant disturbance, since 25% of the total generation of the DC system is lost.

The DC voltage at the four onshore converters is shown in Figure 5. As expected, the loss of load causes the voltage to rise and the loss of generation causes a voltage drop. The total voltage deviation is about 4% which is a good result, regarding the significant disturbance. Probably even lower voltage deviation is achievable, but this has not been attempted yet.

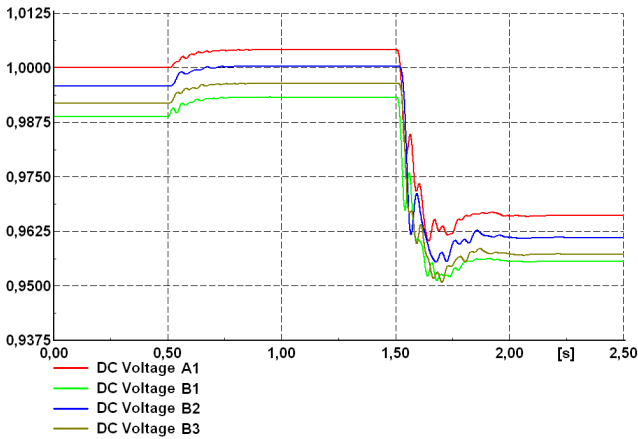

Figure 5: DC Voltage at the four onshore converters

As visible in Figure 5 the voltage profile of the network is changed after the severe disturbance, due to a changed power flow. This is of course a result of the different control strategies of the four converters. The active control power of the four onshore converters is shown in Figure 6.

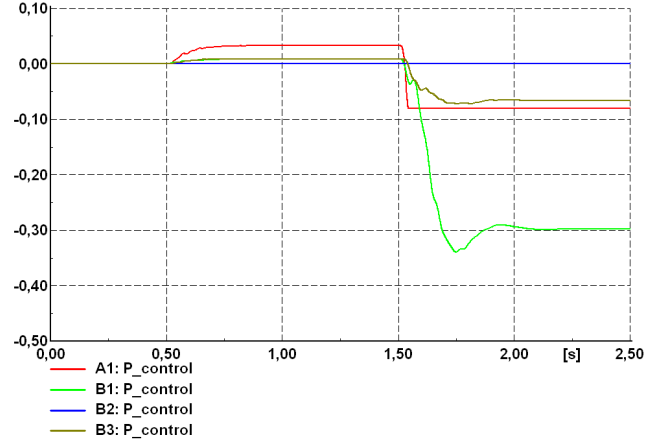

Figure 6: Active control power of the four onshore converters.

The control power is given in pu while 1pu refers to 2000MW. The four strategies are clearly visible in Figure 6. Converter B2 is operating on constant power. Converter A1 absorbs most of the first disturbance, but reaches its limitation during the second heavier disturbance. Converter B1 is supporting during the first disturbance, but carries the main burden during the second disturbance, since system voltage is below the defined undead band, and the control gain is increased significantly. Converter B3 is supporting during both disturbances.

The undead-band control works as expected, demonstrating the validity of the undead-band approach.

5. CONCLUSION AND OUTLOOK

A new active power control method for HVDC converters has been developed and published in [11]. It is especially designed for large meshed DC grids, where control is challenging compared to conventional HVDC systems with a small number of power converters.

The control strategy is droop based, but the converters have separate control gains for normal and disturbed operation. This way the dead-band for normal operation is avoided and replaced by an undead-band with a control gain which is small but larger than zero.

The control method is well suited to achieve high reliability standards due to the distributed control approach.

A significant advantage of the control concept is, that various different control behaviours can be achieved by choosing the parameters correctly. Therefore it is not only a new control strategy, but can also serve as a framework, which includes many existing control strategies.

The control has been implemented in with DIGSILENT Power Factory simulation software, while the needed lookup tables have been generated with MATLAB.

The validity and effectivity of the undead-band control concept has earlier been shown by simulations for a 3-

terminal DC grid test system [11]. Now it has also been validated on the larger CIGRE B4 DC grid test system.

Still in development is the optimisation of the dynamic behaviour of the undead-band control and the application for isolated offshore AC systems. Those two aspects are treated at the moment and the results will be published later.

ACKNOWLEDGEMENT

The authors would like to thank the OffshoreDC consortium, funded by Nordic Energy Research, for initiating the cooperation, which resulted in this article.

We also would like to thank the Centre for renewable energy (SFFE) for funding travel and research visit to DTU Risø, which made this cooperation work possible.

Special thanks also to the members of CIGRE B4 for their contribution to the CIGRE B4 DC grid test system.

REFERENCES

- [1] T.K. Vrana, O.B. Fosso, "Technical Aspects of the North Sea Super Grid", CIGRE Electra, November 2011.
- [2] "Trade Wind", final report, EU-IEE project, 2009. www.trade-wind.eu
- [3] "Offshore Grid Development in the North Seas: ENTSO-E views", 2011. www.entsoe.eu
- [4] "Roadmap to the deployment of offshore wind energy in Central and Southern North Sea to 2030", final report, EU-IEE project Windspeed, March 2011. www.windspeed.eu
- [5] J. de Decker, P. Kreutzkamp, others, "OffshoreGrid: Offshore Electricity Infrastructure in Europe", final report, EU-IEE project OffshoreGrid, October 2011. www.offshoregrid.eu
- [6] "Political declaration on the North Seas Countries Offshore Grid Initiative" Council of the European Union, December 2009. www.consilium.europa.eu
- [7] L. Zeni, T. Haileselassie, G. Stamatou, A. Geisler Eriksen, J. Holbøll, O. Carlsson, K. Uhlen, P. Sørensen, N. Cutululis, "DC grids for integration of large scale wind power", EWEA Offshore Conference, Amsterdam, 2011.
- [8] www.islesproject.eu
- [9] T. Nakajima, S. Irokawa, "A control system for HVDC transmission by voltage sourced converters" Power Engineering Society Summer Meeting, IEEE, volume 2, pages 1113–1119, 1999.
- [10] B.K. Johnson, R.H. Lasseter, F.L. Alvarado, R. Adapa, "Expandable multiterminal dc systems based on voltage droop", IEEE Transactions on Power Delivery, 8(4):1926–1932, 1993.
- [11] T.K. Vrana, L. Zeni, O.B. Fosso, "Active Power Control with Undead-Band Voltage & Frequency Droop for HVDC Converters in Large Meshed DC Grids", EWEA Conference, Copenhagen, April 2012.