

Technical University of Denmark



High phase noise tolerant pilot-tone-aided DP-QPSK optical communication systems

Zhang, Xu; Pang, Xiaodan; Deng, Lei; Zibar, Darko; Tafur Monroy, Idelfonso ; Younce, Richard

Published in:
Optics Express

Link to article, DOI:
[10.1364/OE.20.019990](https://doi.org/10.1364/OE.20.019990)

Publication date:
2012

Document Version
Publisher's PDF, also known as Version of record

[Link back to DTU Orbit](#)

Citation (APA):
Zhang, X., Pang, X., Deng, L., Zibar, D., Tafur Monroy, I., & Younce, R. (2012). High phase noise tolerant pilot-tone-aided DP-QPSK optical communication systems. *Optics Express*, 20(18), 19990-19995. DOI: 10.1364/OE.20.019990

DTU Library

Technical Information Center of Denmark

General rights

Copyright and moral rights for the publications made accessible in the public portal are retained by the authors and/or other copyright owners and it is a condition of accessing publications that users recognise and abide by the legal requirements associated with these rights.

- Users may download and print one copy of any publication from the public portal for the purpose of private study or research.
- You may not further distribute the material or use it for any profit-making activity or commercial gain
- You may freely distribute the URL identifying the publication in the public portal

If you believe that this document breaches copyright please contact us providing details, and we will remove access to the work immediately and investigate your claim.

High phase noise tolerant pilot-tone-aided DP-QPSK optical communication systems

Xu Zhang,^{1*} Xiaodan Pang,¹ Lei Deng,¹ Darko Zibar,¹ Idelfonso Tafur Monroy,¹ and Richard Younce²

¹DTU Fotonik, Department of Photonics Engineering, Technical University of Denmark

²Tellabs, 1415 West Diehl Road, Naperville, IL 60563, USA

*xuzhn@fotonik.dtu.dk

Abstract: In this paper we experimentally demonstrate a novel, high phase-noise tolerant, optical dual polarization (DP) quadrature phase-shift keying (QPSK) communication system based on pilot-tone-aided phase noise cancellation (PNC) algorithm. Vertical cavity surface emitting lasers (VCSELs) with approximate 300 MHz linewidth are used as transmitters and local oscillators for coherent detection of optical DP-QPSK signals. The proposed system, with central wavelength at 1540.68 nm, operates at 40 Gb/s over 80 km single mode fiber (SMF) as part of a passive optical network (PON). The deployment of pilot-tone-aided PNC algorithm guarantees a bit error rate (BER) performance below the forward error correction (FEC) threshold. Moreover, we also evaluate a novel digital signal processing (DSP) algorithm for adaptive pilot tone detection.

© 2012 Optical Society of America

OCIS codes: (060.1660) Coherent communication; (060.2330) Fiber optics communications.

References and links

1. F. Machi, M. S. Alfiad, M. Kuschnerov, T. Wuth, D. van den Borne, N. Hanik, and H. de Waardt "111-Gb/s PolMux-quadrature duobinary for robust and bandwidth efficient transmission," *IEEE Photon. Technology Letter*, **22**, 751–753 (2010).
2. X. Zhou and J. Yu, "Advanced coherent modulation formats and algorithms: higher-order multi-level coding for high-capacity system based on 100 Gbps channel," *Conference on Optical Fiber Communication (OFC)*, (2010).
3. G. P. Agrawal, *Fiber-Optic Communication Systems*, 3rd ed. (John Wiley & Sons, Inc., 2002).
4. M. Seimetz, "Laser linewidth limitations for optical systems with high-order modulation employing feed forward digital carrier phase estimation," *Conference on Optical Fiber Communication (OFC)* (2008).
5. J. K. Cavers, "An analysis of pilot symbol assisted modulation for rayleigh fading channels," *IEEE Trans. Veh. Technol.* **40**, 686–693 (1991).
6. A. Spalvieri and L. Barletta, "Pilot-aided carrier recovery in the presence of phase noise," *IEEE Trans. Commun.* **59**, 1966–1974 (2011).
7. S. L. Jansen, I. Morita, T. C. W. Schenk, N. Takeda, and H. Tanaka, "Coherent optical 25.8-Gb/s OFDM transmission over 4160-km SSMF," *J. Lightwave Technol.* **26**, 6–15 (2008).
8. S.-Yuep Kim, N. Sakurai, H. Kimura, and H. Hadama, "VCSEL-based coherent detection of 10-Gbits/s QPSK signals using digital phase noise cancellation for future optical access systems," *Conference on Optical Fiber Communication (OFC)* (2010), paper OMK6.
9. R. Rodes, J. B. Jensen, D. Zibar, C. Neumeyr, E. Roenneberg, J. Roskopf, M. Ortsiefer, and I. T. Monroy, "All-VCSEL based on digital coherent detection link for multi Gb/s WDM passive optical networks," *Opt. Express*, **18**, 24969–24974 (2010).
10. M. H. Morsy-Osaman, L. R. Chen, and D. V. Plant, "Joint mitigation of laser phase noise and fiber nonlinearity using pilot-aided transmission for single-carrier systems," *European Conference and Exhibition on Optical Communication (ECOC)* (2011), paper Tu.3.A.3.

1. Introduction

Next generation optical communication systems will be required to fulfill a set of different technical requirements, such as high capacity, better spectral efficiency and system flexibility. Optical transmission systems using multilevel signals with coherent detection have become a promising solution to meet the increasing demand of capacity increase [1]. There are different reasons why the utilization of coherent detection can be very beneficial. Firstly, coherent detection is able to support advanced modulation formats with improved spectral efficiency, such as n phase-shift keying (PSK). Secondly, coherent detection provides potential for superior signal sensitivity and enables off-line DSP compensation of impairments arising from signal transmission [2]. However, an essential sensitivity degrading source in coherent system is phase noise associated to the transmitter and local oscillator (LO) lasers. Both, signal phase noise and LO phase noise lead to optical signal to noise ratio (OSNR) degradation [3]. As the phase stability of a laser is inversely proportional to its linewidth, then intolerance to the laser linewidth is an essential limitation in coherent system. For instance, the entire linewidth tolerance of transmitter and local oscillator laser in 10 Gbaud quadrature phase-shift keying (QPSK) coherent systems is 10 MHz per laser [4]. Due to these strict phase noise limitation, external cavity lasers (ECL) or distributed feedback (DFB) lasers with narrow linewidth are required for stable system operation. Additional challenges for future optical communication systems include power consumption efficiency and less complex configuration with improved linewidth tolerance. To deal with this problem, off-line DSP phase noise cancellation (PNC) algorithms are considered as an efficient substitute solution. One of these methods include pilot-aided DSP. This algorithm was first demonstrated in the field of electrical wireless communication systems [5], in which it was successfully demonstrated for phase noise cancellation [6]. In optical communication systems, pilot-tone-aided PNC algorithm was firstly applied for coherent OFDM transmission [7]. With pilot-tone-aided, VCSEL utilization in coherent systems has emerged as a feasible technique. The important benefits of using VCSELs are cost efficiency and low power consumption [8]. However, due to the fact that the linewidth of commercial available VCSELs is approximately 300 MHz [9], phase noise induced by VCSELs severely degrades the system sensitivity. Therefore, according to [8], systems require pilot-tone added in an orthogonal polarization state to act as phase reference for the DSP part of the coherent receiver.

In this paper, we propose a novel implementation of pilot-tone-aided transmission in DP-QPSK single-carrier coherent systems to mitigate phase noise induced by transmitter and local oscillator VCSELs. Pilot tone insertion is enabled by external double sideband modulation of signal carrier, which is located at double sideband first-null-point of the signal spectrum. Moreover, compared to [10], we experimentally demonstrate a novel adaptive DSP pilot-tone detection algorithm to avoid using spectrum overhead. Results show that the proposed pilot-tone-aided algorithm is capable of mitigating phase noise and improve laser linewidth tolerance of 10 Gbaud QPSK coherent system from 10 MHz per laser to 300 MHz per laser.

2. Theoretical overview of the pilot-tone-aided technique

A complex modulated signal, whose information lies not only on its amplitude but phase as well, can be written as

$$E_s(t) = [A_I(t) + iA_Q(t)] \exp[i(\omega_s t + \phi_s)], \quad (1)$$

where ω_s and ϕ_s are the signal's carrier frequency and time dependent phase variable, and $A_I(t)$ and $A_Q(t)$ are respectively the real (in phase) and imaginary (quadrature) parts of the signal. In coherent system, the detection of the received signal is achieved by combining it with an external optical field represented by the local oscillator (LO). In our implementation, shown in

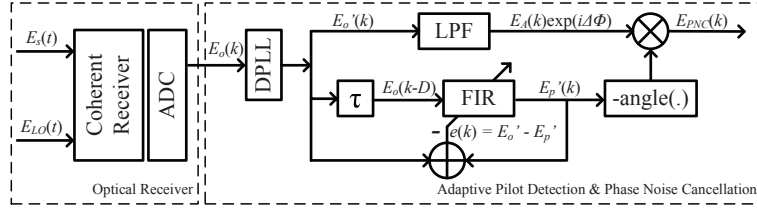

Fig. 1. Pilot-tone-aided PNC using adaptive pilot tone detection schematic (see Eq. (4)–(10) for more details). ADC: analogue to digital converter; DPLL: digital phase lock loop; LPF: low pass filter; τ : delay line; FIR: finite impulse response equalizer.

Fig. 1, the coherent receiver is of heterodyne type, meaning that the central frequency of the LO is different from the central frequency of the transmitted signal. Similarly to the received signal, the optical field associated with the LO can be written as

$$E_{LO}(t) = A_{LO}(t) \exp[i(\omega_{LO}t + \phi_{LO})], \quad (2)$$

where ω_{LO} , $A_{LO}(t)$ and ϕ_{LO} are respectively the carrier frequency, amplitude and time dependent phase variable of the LO. The pilot tone insertion, enabled by external double sideband modulation, can be written as

$$E_p(t) = A_p(t) \exp[i(\omega_s t - \omega_p t + \phi_p)] + A_p(t) \exp[i(\omega_s t + \omega_p t + \phi_p)], \quad (3)$$

with ω_p , $A_p(t)$ and ϕ_p being the carrier frequency, amplitude and time dependent phase variable of the pilot tone. Hence, the signal at the input of the coherent receiver (excluding the LO) can be expressed as the summation of received signal $E_s(t)$, pilot signal $E_p(t)$ and additive in-band noise $n(t)$ with zero mean and σ_n^2 variance. The signals into the coherent receiver are assumed to be identically polarized. However, polarization mismatch issues are solved at the receiver by an off-line DSP polarization demultiplexing. Therefore the output signal from the 90°-hybrid and balanced photodetectors is given as

$$E_o(t) = E_R \exp[i(\Delta\omega t + \omega_p t + \Delta\phi')] + E_R \exp[i(\Delta\omega t - \omega_p t + \Delta\phi')] - E_A \exp[i(\Delta\omega t + \Delta\phi)], \quad (4)$$

with

$$E_R = 8E_p(t)E_{LO}(t), \quad \Delta\omega \equiv \omega_s - \omega_{LO}, \quad \text{and} \quad E_A = E_{LO}(t)[A_I(t) + iA_Q(t)]. \quad (5)$$

As it can be seen, the output signal $E_o(t)$ consists of three terms, where the first and second term represent the double sideband pilot tone combined with the LO. Moreover, E_R is the amplitude of double sideband components. E_A is the amplitude of baseband component. The third term represents the beating between signal and LO, and as the detection is heterodyne then $\Delta\omega \neq 0$. The phase offsets, $\Delta\phi$ and $\Delta\phi'$, respectively of the original signal and pilot tone in (4) are given as

$$\begin{bmatrix} \Delta\phi \\ \Delta\phi' \end{bmatrix} = \begin{bmatrix} \phi_s - \phi_{LO} + \phi_n \\ \phi_p - \phi_{LO} + \phi_n' \end{bmatrix}, \quad (6)$$

where ϕ_n is the random phase noise of the original signal and ϕ_n' is the phase noise of pilot tone. As the output signal from the 90°-hybrid $E_o(t)$ is sampled by analog to digital converters (ADC), the k -th element of the output from the sampling process is denoted by $E_o(k)$. Due to DSP utilization, the pilot-tone-aided PNC algorithms firstly employs digital phase lock loop (DPLL) to compensate the frequency offset $\Delta\omega(k)$:

$$E_o'(k) = E_o(k) \exp[-i\Delta\omega(k)]. \quad (7)$$

Digital low-pass filtering (LPF) is required to determine $E_A \exp[i(\Delta\phi)]$ in (4). Consequently the adaptive pilot-tone detection filter is implemented to detect pilot tone and estimate phase noise. The general configuration of the adaptive pilot-tone detection algorithm is shown in Fig. 1. This algorithm is widely used to suppress narrowband interference in a wideband signal in spread-spectrum wireless communications. In the case of pilot-tone-aided PNC, the transmitted signal sequence $E_o(k)$ is assumed to be wideband, and the pilot tone $E_p(k)$ is assumed to be a narrowband sequence instead. As, in the time domain, the two sequences are uncorrelated, a finite impulse response (FIR) filter design is able to detect the narrowband pilot tone from the transmitted signal. The narrowband characteristics of the pilot tone enable the pilot tone estimation from past samples of the received signal $E_o(k)$. The delayed sample $E_o(k-D)$ is used to estimate the pilot tone in the spectral domain. As the spectrum of the pilot tone is much narrower compared to the signal, then $D = 1$ is selected in order to meet the uncorrelation requirement. The resulting output of the FIR filter is given as

$$E_p'(k) = \sum_{n=0}^{N-1} h(n)E_o(k-n-D), (k = 1, 2, \dots; n = 0, 1, 2, \dots, N-1), \quad (8)$$

where $h(n)$ are the FIR filter coefficients and the error signal used in adaptive FIR filter coefficients optimization is $e(k) = E_o'(k) - E_p'(k)$. The minimum summation of errors leads to the determination of the optimal FIR coefficients. After optimization of the FIR coefficients, such equalizer places an adaptive peak in the frequency band occupied by the pilot. In our implementation, 7-taps of adaptive FIR filter is applied. According to the delay D , the least mean square (LMS) algorithm for the coefficients optimization is

$$h_k(n) = h_{k-1}(n) + e(k)E_o(k-n-D), (k = 1, 2, \dots; n = 0, 1, 2, \dots, N-1). \quad (9)$$

The pilot-to-signal ratio (PSR) at first-null-point of the signal spectrum has a significant influence on the receiver's performance. In case the spectral characteristic of the pilot tone is Gaussian with normal distribution, then PSR is equal to $-10 \log_{10} \exp(-\Delta\nu^2)$, with $\Delta\nu$ being the pilot tone laser linewidth. In the experiment, $\text{PSR} > 7\text{dB}$ is selected to guarantee a linewidth tolerance to approximately 300 MHz per laser in the 10 Gbaud DP-QPSK coherent system. Furthermore, due to the delay lengths are kept the same, pilot tone and transmitted signal share the same phase noise, hence $\Delta\phi = \Delta\phi'$. This means that analysis of signal PNC is expressed as

$$E_{PNC}(k) = E_A(k) \exp[i\Delta\phi] \exp(-i\Delta\phi'), \quad (10)$$

which results in the phase noise combined with transmitted signal to be canceled out

$$E_{PNC}(k) = E_A(k). \quad (11)$$

3. Experiment setup

Figure 2 shows the experiment setup for a 40-Gb/s DP-QPSK transmission system based on pilot-tone-aided PNC algorithm. At the transmitter side, the optical source consists of a single VCSEL operating at 1540.68 nm (194.5845 THz) with maximum output power 2 dBm, which is used to generate both signal and pilot tone. The electrical signal source is a pulse pattern generator (PPG) working at 10 Gbaud and generating a pattern of $2^{15}-1$ bits used to drive the optical I/Q modulator. An external Mach-Zehnder modulator (MZM) driven by an electrical synthesizer is used to generate the pilot tone, which is placed at the double sideband first-null-point (10 GHz) of the signal spectrum. Hence, after they are optically combined, both pilot tone and QPSK signal experience the same type of phase noise. In order to generate

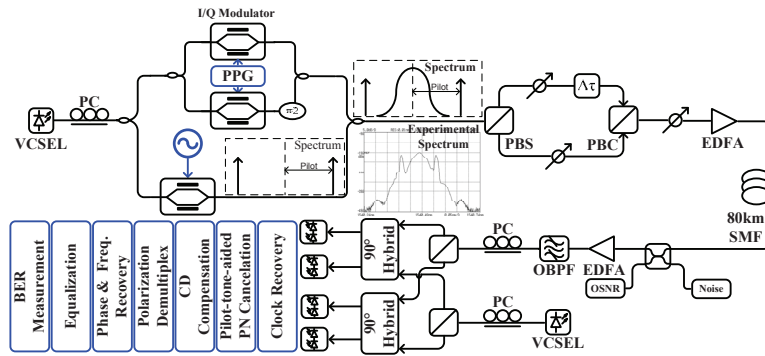

Fig. 2. Pilot-tone-aided PNC experiment setup. PPG: pulse pattern generator; PBS: polarization beam splitter; PBC: polarization beam combiner; EDFA: erbium-doped optical fiber amplifier; SMF: single-mode fiber; OBPF: optical band pass filter.

a dual polarization state the optical signal is separated into two orthogonal polarizations by a polarization beam splitter (PBS). Before recombination in a polarization beam combiner (PBC), one of the polarization states propagates through an optical delay line, which decorrelates it from the other orthogonal state. The resulting optical signal is a pilot-tone-aided 40 Gb/s DP-QPSK signal. The pre-amplified receiver consists of a second VCSEL operating at 1540.67 nm (194.5857 THz) with maximum output power 0 dBm used as LO, two 90°-hybrids (dual polarization operation), balanced detectors, a 40 GSa/s digital sampling oscilloscope which is used to sample the in-phase and quadrature components from the received signal, and a computer for signal processing. VCSELs using temperature controller are able to be stably operated at separate frequency points which induce intermediate frequency of 1.2 GHz. The off-line DSP algorithm blocks are shown in Fig. 2. The first block consists of pilot-tone-aided PNC, followed by clock recovery. The frequency domain chromatic dispersion (CD) compensation algorithm is used to compensate for 80 km SMF transmission, and is followed by the constant modulus algorithm (CMA), utilized to enable polarization demultiplexing. Phase and frequency recovery based on Viterbi-Viterbi algorithm is employed to compensate the residual phase and frequency offset after pilot-tone-aided PNC. A decision feed-forward and a decision feedback FIR equalizer are implemented to compensate inter symbol interference, and hence improve system performance. Bit error detection is also applied to evaluate the system's performance.

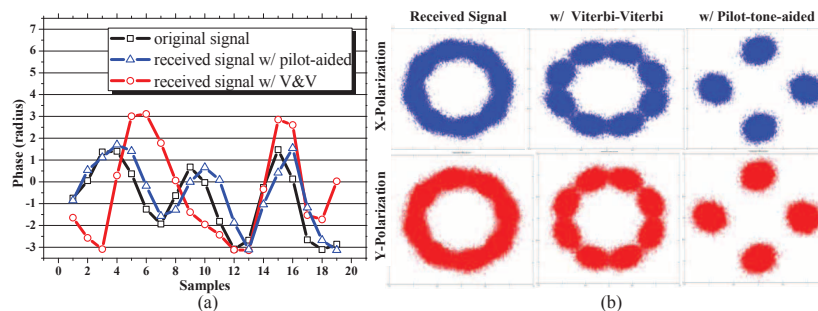

Fig. 3. Pilot-tone-aided PNC experiment results: (a) phase tracking results ($D=1$); (b) constellation of two orthogonally polarized received signal: output using Vibterbi-Viterbi and pilot-tone-aided PNC.

4. Experiment results

Figure 3(a) shows the phase tracking comparison results between pilot-tone-aided PNC algorithm and Viterbi-Viterbi phase recovery algorithm. As it can be noticed, the pilot-tone-aided algorithm is able to track the original phase information from the transmitted signal. Figure 3(b) shows the constellations diagrams for the 40 Gb/s DP-QPSK signal generated by using the Viterbi-Viterbi or the pilot-tone-aided algorithm. Because of the large laser linewidth Viterbi-Viterbi algorithm results in uncorrect phase recovery. As it is shown in Fig. 3(b), Viterbi-Viterbi phase recovery leads to eight clusters in constellation diagram. Meanwhile constellation rotation caused by phase noise is successfully compensated by using the pilot-tone-aided algorithm. As a result, four clusters for QPSK signals are shown clearly in Fig. 3(b).

Simulation results of 40-Gb/s DP-QPSK transmission using PNC with 13 dB OSNR are shown in Fig. 4(a). Figure 4(b) shows the measured BER performance for single- and dual-polarization QPSK systems in back-to-back and after 80 km transmission in SMF. CD compensation is performed via off-line processing at the receiver side. As a result, the BER performance difference between back-to-back and 80 km SMF transmission is less than 0.5 dB. Furthermore, the utilization of the pilot-aided-tone PNC guarantees the BER performance below the threshold of 7%-overhead FEC.

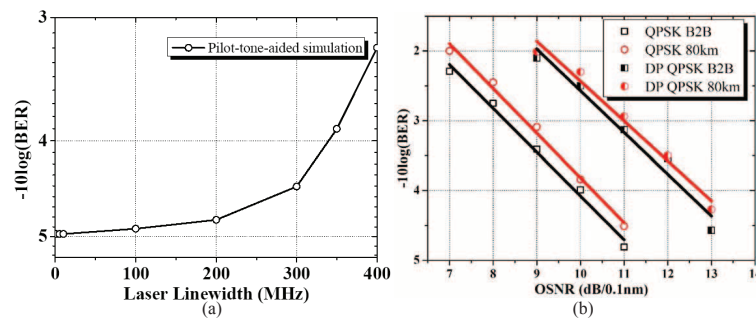

Fig. 4. Bit-error ratio (BER) performance of pilot-tone-aided PNC: (a) simulation results of BER in terms of single laser linewidth (OSNR=13 dB); (b) experiment BER results.

5. Conclusion

In this paper we presented experimental results for a high phase-noise tolerant pilot-tone-aided 40 Gb/s DP-QPSK optical coherent system. Both transmitter and LO lasers were free running VCSELs with approximately 300 MHz linewidths. An 80 km SMF transmission for PON system was successfully demonstrated by using pilot-tone-aided and off-line DSP dispersion compensation algorithms. Instead of using conventional bandpass filter to detect pilot tone, novel adaptive FIR pilot-tone detection algorithm is proposed. Furthermore, such adaptive FIR pilot-tone detection algorithm is suitable for real time DSP with block-wise processing modification. In our implementation, the pilot tones are employed at the double-side first-null-point of the signal spectrum with no need for overhead in the frequency domain. For instance, in 40 Gb/s DP-QPSK systems, the pilot tones are inserted at 10 GHz first-null-point of transmitted signal. Additionally, the manuscript presents also a comparison between pilot-tone-aided and Viterbi-Viterbi phase recovery algorithms. The implementation of the pilot-tone-aided algorithm resulted in a BER performance below 7%-FEC threshold. According to theoretical analysis, a linewidth tolerance of approximately 10 MHz per laser for a 40 Gb/s DP-QPSK coherent system has been improved to 300 MHz.