

Technical University of Denmark



Control of SHARON reactor for autotrophic nitrogen removal in two-reactor configuration

Valverde Pérez, Borja; Mauricio Iglesias, Miguel; Sin, Gürkan

Published in:
Proceedings of EcoTechnologies for Wastewater Treatment 2012

Publication date:
2012

[Link back to DTU Orbit](#)

Citation (APA):
Valverde Perez, B., Mauricio Iglesias, M., & Sin, G. (2012). Control of SHARON reactor for autotrophic nitrogen removal in two-reactor configuration. In Proceedings of EcoTechnologies for Wastewater Treatment 2012

DTU Library

Technical Information Center of Denmark

General rights

Copyright and moral rights for the publications made accessible in the public portal are retained by the authors and/or other copyright owners and it is a condition of accessing publications that users recognise and abide by the legal requirements associated with these rights.

- Users may download and print one copy of any publication from the public portal for the purpose of private study or research.
- You may not further distribute the material or use it for any profit-making activity or commercial gain
- You may freely distribute the URL identifying the publication in the public portal

If you believe that this document breaches copyright please contact us providing details, and we will remove access to the work immediately and investigate your claim.

Control of SHARON reactor for autotrophic nitrogen removal in two-reactor configuration

B. Valverde-Pérez, M.Mauricio-Iglesias* and G. Sin

* Department of Chemical and Biochemical Engineering, Technical University of Denmark, Building 229, Søtofts Plads, 2800 Lyngby, Denmark (E-mail: mim@kt.dtu.dk),

Abstract

With the perspective of investigating a suitable control design for autotrophic nitrogen removal, this work explores the control design for a SHARON reactor. With this aim, a full model is developed, including the pH dependency, in order to simulate the reactor and determine the optimal operating conditions. Then, the screening of controlled variables and pairing is carried out by an assessment of the effect of the disturbances based on the closed loop disturbance gain plots. Two controlled structures are obtained and benchmarked by their capacity to reject the disturbances before the Anammox reactor.

Keywords

Autotrophic nitrogen removal, disturbance analysis, plantwide control, modelling

1. Introduction

Complete autotrophic nitrogen removal (CANR) is especially suitable for wastewaters containing high concentrations of nitrogen and low organic carbon to nitrogen ratios, such as sludge digestion liquor, landfill leachate, or special industrial wastewaters, conventional nitrification-denitrification as the needs of carbon addition and aeration. Based on it, the SHARON process, which stands for Single reactor High activity Ammonia Removal Over Nitrite, (Hellinga et al. 1998), was designed first on the following sequences: i) the partial nitrification of the ammonium by aerobic oxidizing bacteria (AOB) and ii) the denitrification to nitrogen gas by heterotroph bacteria (HB). An alternative option to this second step is the so-called anaerobic ammonium oxidation (Anammox, Mulder et al. 1995). The process achieves a total ammonium conversion using equimolar amounts of ammonium and nitrite. This process presents some additional advantages, like the lowering of gases with greenhouse effect (CO_2 and NO_2) or the elimination of external carbon sources. Its main drawback is related to the low growth rate of Anammox bacteria, involving the use of sludge retention systems, e.g. membranes, granular systems. Besides, in order to achieve a high elimination of all the nitrogen sources, it must be ensured that the ammonium and nitrite are fed in stable, close to equimolar proportions. Therefore, a performing control system is essential to ensure the balance between ammonium and nitrite to the Anammox reactor. Some strategies have been applied in this field in order to optimize the nitrogen removal costs (Volcke et al. 2005) based in different control loops for the key variables in the process, as pH or dissolved oxygen (DO). The goal of this contribution is to assess the most suitable control structures to stabilize the SHARON reactor based on an analysis of the disturbances and selection of controlled variables.

2. Methods

2.1 Reactor description

The case study used in this work is adapted from an experimental description previously reported (Galí et al. 2007). The reactor is a continuous stirred tank reactor (CSTR) with a volume of 4 l and a hydraulic retention time of 1 day, with operating conditions 30°C, pH 7.23 and dissolved oxygen 1.06 g m^{-3} (the determination of optimal pH and DO is done in section 3.1), which implies a nominal $k_L a$ of 192 d^{-1} at steady state conditions. The influent composition is 700 N- g m^{-3} of ammonium, 600 C- g m^{-3} of bicarbonate (equimolar) and 27 g m^{-3} of inorganic phosphorous.

2.2 Reactor modelling

The model used to describe the process is adapted from previously published work by Hellinga et al. (1999) and Volcke (2006). The compartment was modeled as a CSTR. Assuming that the reactor

hold-up and all the inflows and outflows have the same constant density, the total and partial mass balances are:

$$\frac{dV}{dt} = \sum_{i=1}^n F_i^{IN} - F^{OUT} \quad (1)$$

$$\frac{d(V \cdot C_i)}{dt} = F_i^{IN} \cdot C_i^{IN} - F^{OUT} \cdot C_i + k_L a \cdot (C_i^* - C_i) \cdot V + r_i \cdot V \quad (2)$$

where F stands for the volumetric flows, C for the concentrations, r for the reaction rate and V for the volume of the reactor. The subscripts IN and OUT stand for inflow and outflow respectively, i for each component and $*$ for the equilibrium concentrations. The individual mass balances developed are described for the lumped compounds, i.e. ionized and unionized forms. The components considered are: H^+ , NH_4^+ , NH_3 , HNO_2 , NO_2^- , CO_2 , HCO_3^- , CO_3^{2-} , $H_2PO_4^-$, HPO_4^{2-} , NO_3^- , O_2 , N_2 , ammonia oxidizing bacteria (AOB), nitrite oxidizing bacteria (NOB), heterotrophic bacteria (HB) and Z (charge not involved in biological reactions). Absorption or stripping in (2) only applies for O_2 and CO_2 . The partition coefficients of O_2 and CO_2 are determined by Henry's law (Villadsen, Nielsen & Liden 2011).

2.3 Reaction modelling

Five different biological reactions are included in the SHARON model. The nitrification process is divided in two different steps: the oxidation of the ammonia to nitrite, carrying out by AOB, and the oxidation of the nitrite to nitrate, carrying out by NOB. In order to take account of the microbial growth in the mass balances, the biomass composition is fixed as $CH_{1.8}O_{0.5}N_{0.2}$. The stoichiometric matrix and the expressions of the process rates for the two reactors appear in the Appendix.

2.4 Determination of pH

The microbial activity affects to the pH since the reactions imply a production (partial nitrification) of protons. The pH is determined solving the corresponding mass balances (3a-d), equilibrium equations (4a-f) and charge balance (5). The resulting system of 13 nonlinear equations is solved by a multidimensional Newton-Raphson method adapted from Luff et al. (2001).

$$0 = TNH - (NH_4^+ + NH_3) \quad (3a)$$

$$0 = TNO - (HNO_2 + NO_2^-) \quad (3b)$$

$$0 = TIC - (CO_2 + HCO_3^- + CO_3^{2-}) \quad (3c)$$

$$0 = TIP - (H_2PO_4^- + HPO_4^{2-}) \quad (3d)$$

$$0 = K_w - OH^- \cdot H^+ \quad (4a)$$

$$0 = K_{e,NH_4} \cdot NH_4^+ - NH_3 \cdot H^+ \quad (4b)$$

$$0 = K_{e,HNO_2} \cdot HNO_2 - NO_2^- \cdot H^+ \quad (4c)$$

$$0 = K_{e,CO_2} \cdot CO_2 - HCO_3^- \cdot H^+ \quad (4d)$$

$$0 = K_{e,HCO_3} \cdot HCO_3^- - CO_3^{2-} \cdot H^+ \quad (4e)$$

$$0 = K_{e,H_2PO_4} \cdot H_2PO_4^- - HPO_4^{2-} \cdot H^+ \quad (4f)$$

$$0 = Z^+ - NO_3^- - HCO_3^- - 2 \cdot CO_3^{2-} - H_2PO_4^- - 2 \cdot HPO_4^{2-} - NO_2^- - OH^- + NH_4^+ + H^+ \quad (5)$$

2.5 Controller modelling

All the controllers used in this work are proportional-integral controllers (PI). Sensors and actuators are modeled as perfect (immediate response with perfect accuracy) given the slow response of the system. Unless stated otherwise, the controllers were tuned using the internal model control guidelines (Seborg, Edgar & Mellichamp 2004).

The model was implemented and solved in Simulink environment in MATLAB R2009b (The MathWorks, Natick, MA).

3. Control structure design

3.1 Determination of operating conditions

As a previous step to control design, the optimal operation conditions in the SHARON reactor were determined mapping the effect of pH and dissolved oxygen (DO) in the performance of the reactor. The bounds considered were between 6.5 and 8 for pH, and between 0 g m^{-3} and 8.96 g m^{-3} (saturation) for DO. For each value of oxygen and pH the steady state was determined and, in particular, the ratio between the total nitrite mass (i.e. nitrous acid plus the nitrite anion, TNO) and the total ammonium mass (i.e. the ammonium cation plus ammonia, TNH) was recorded. The optimal TNO_2/TNH ratio in the influent of an Anammox reactor is 1.3 provided that anaerobic oxidation is the only reaction taking place (Van de Graaf et al. 1995). The dependency of the TNO_2/TNH ratio shows a maximum at pH 7.23 and a monotonous increase with DO which stabilizes asymptotically for excess of oxygen (Fig. 1). Therefore, in order to operate at minimum DO, and as a consequence decrease the needs of aeration, the operating conditions were selected as $\text{pH}=7.23$ and $\text{DO}=1.06 \text{ g m}^{-3}$, corresponding to a ratio TNO_2/TNH of 1.3.

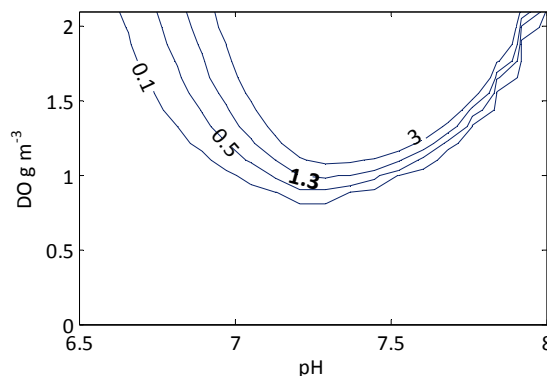

Figure 1. Contour plot of the molar ratio TNO_2/TNH in function of pH and DO levels at steady state

3.2 Control objectives and degrees of freedom analysis

As stated earlier, the goal of the SHARON reactor is to provide a stable feed for the Anammox reactor of with a molar ratio TNO_2/TNH of 1.3. This is the primary objective that can be achieved using the molar ratio TNO_2/TNH as a control variable or can be approximated by keeping the system at the selected operating conditions. If the SHARON reactor is directly fed from a digester, the feed flow is a disturbance and therefore the level has to be controlled using the outflow as a manipulated variable (MV). As a consequence, there are only two manipulated variables left: aeration (represented by $k_L a$) and the acid/base flow. The identified controlled variables (CV) and disturbances are summarized in Fig. 2.

3.3 Assessment of disturbance effect and pairing

One of the main difficulties in the control of the SHARON reactor is the limited number of available actuators. Indeed, the four CV cannot be controlled simultaneously. The hydraulic residence time (HRT) must be kept above 0.89 days in order to ensure that the NOB are washed out at the operating conditions. We decided to keep it uncontrolled but at a nominal value of 1 day to ensure that the disturbances in the feed flow would not decrease it below the limit of 0.89 days. Out of the three remaining CV, it can be argued that the most important is the ratio TNO_2/TNH since it is the primary objective of the system, although pH and DO are essential to keep the reactor stable. In order to rationally screen the CV to be paired with the available MVs, we assessed the pairings that would reject most easily the disturbances at different frequencies by the closed loop disturbance gain (CLDG) (Hovd, Skogestad 1992).

The CLDG is defined as:

$$CLDG \equiv \Delta = \text{diag}(G)G^{-1}G_d \quad (6)$$

where G is the plant transfer function, $\text{diag}(G)$ is the matrix consisting of diagonal elements of G and G_d is the disturbance transfer function. The magnitude of the CLDG element δ_{ij} indicates the effect of the i th disturbance on the j th controlled variable at any given frequency. If the variables are suitably scaled, a δ_{ij} lower than 1 indicates that the disturbance will not lead the controlled variable to an unacceptable offset. The manipulated variables were scaled around their nominal values and the disturbances around $\pm 10\%$ of their nominal values. The controlled variables were scaled the following way: the maximum offset considered for the ratio TNO_2/TNH was ± 0.5 . Then, the equivalent deviation in DO and pH was determined with the data from Fig. 1, resulting in 0.16 g m^{-3} for DO and 0.2 units for pH.

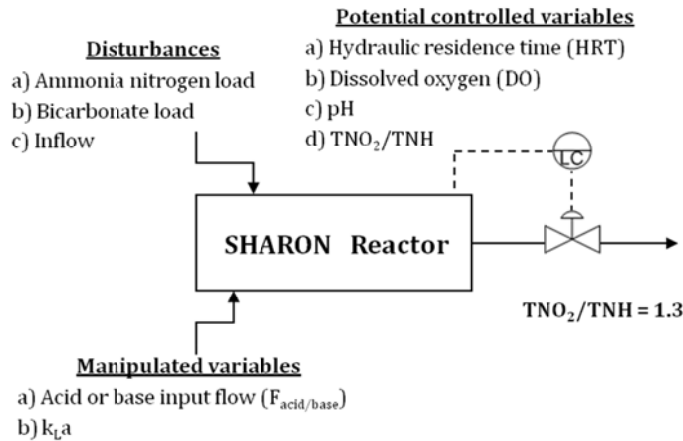

Figure 2. Diagram of the SHARON reactor displaying the manipulated variables, the disturbances and candidates to controlled variables.

The CLDG plots were obtained for the three combinations of CV-MV and the three disturbances (Fig. 3). The CLDG plots for the bicarbonate load are not shown since all the elements were well below 1.

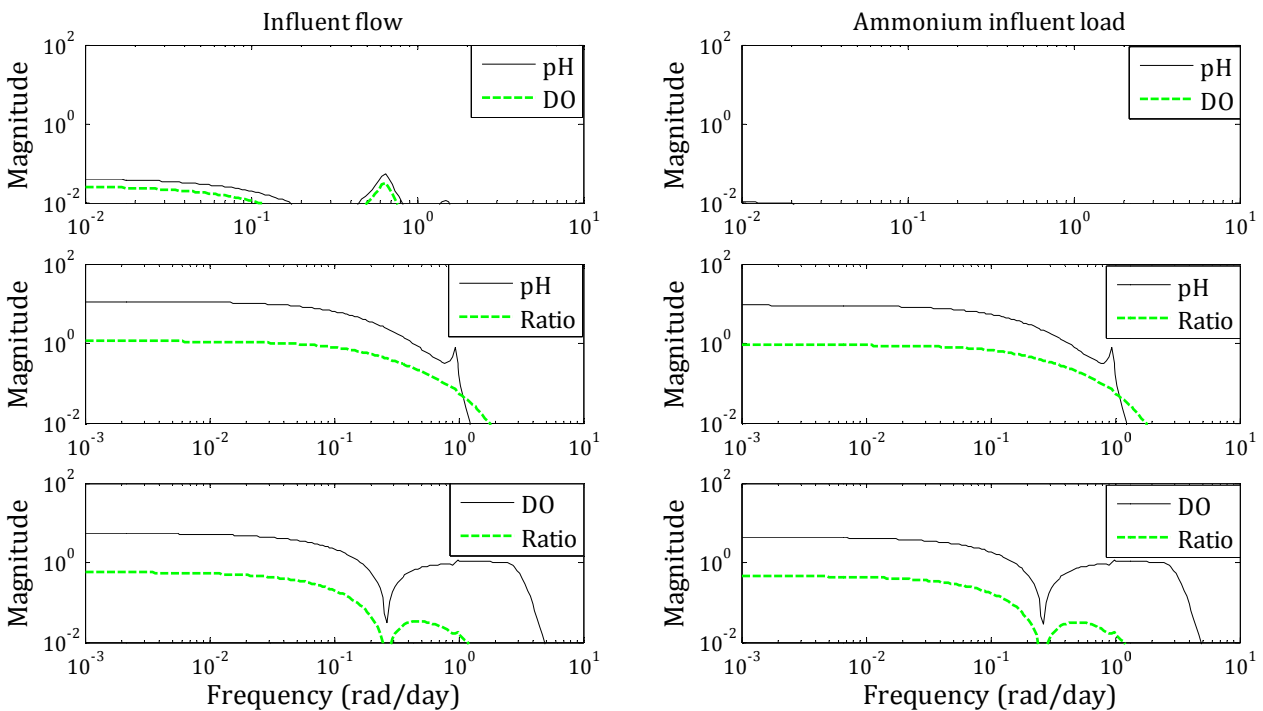

Figure 3. CLDG plots for a disturbance in the influent flow and ammonium influent load

From the CLDG plots it is clear that the structure that pairs the MV with the pH and the DO manages to reject the disturbances more efficiently at all the frequencies than those which consider the TNO_2/TNH ratio directly as a CV. Therefore the decentralized control structure used to stabilize the system is $F_{acid/base} - pH$ and $k_{La} - DO$. However, this structure cannot ensure that the TNO_2/TNH ratio will be kept at its optimal value. Therefore, a second structure is proposed where the setpoint for DO is set by a master loop controlling the TNO_2/TNH ratio (Fig. 4).

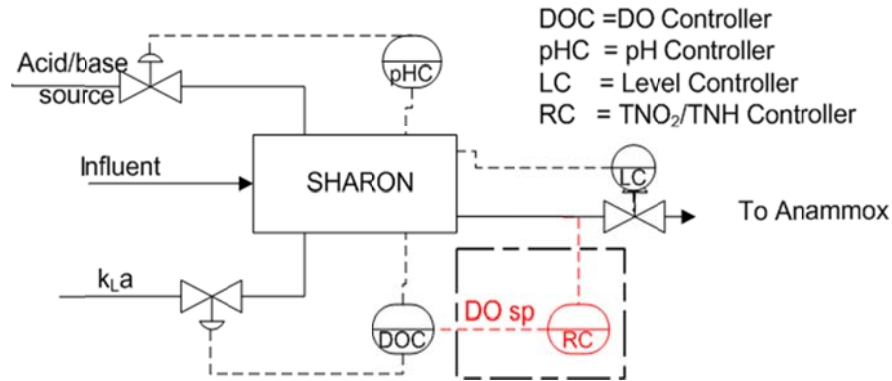

Figure 4. Control structures proposed. The master loop inside the dashed box is only active in the second control structure.

4. Results

The two proposed control structures were tested for disturbance rejection of +5% step changes in influent flow and in ammonium load in the influent. Two types of performance indicators were determined: the integral of absolute error, which measures the offset of the controlled variables and the total variance of manipulated variables, which represents the variations in control action needed to reject the disturbance. The results show that the cascaded controller, not only keeps the TNO_2/TNH ratio close to the optimal value, but it also helps on stabilizing the system. Indeed, the variations of pH are less pronounced in the cascaded structure since changing the DO setpoint helps on stabilizing the microbial community, and therefore avoiding large variations in the reactions.

Table 1. Key performance indicators for the control structures proposed for disturbance rejection. Note that the IAE of DO is very high in the cascaded controller due to the sudden setpoint change.

Control structure	Integral of absolute error			Total Variance of MV		
	pH (d)	DO ($g\ m^{-3}\ d$)	R (d)	$F_{base/acid}$ ($m^3 d^{-1}$)	kLa (d^{-1})	DO _{sp} ($g\ m^{-3}\ d$)
+5% step change in influent flow						
No cascade	$43.8\ 10^{-3}$	0.023	–	$7.40\ 10^{-6}$	16.9	–
Cascade	$6.00\ 10^{-3}$	3.35	0.063	$1.81\ 10^{-6}$	13.1	0.152
+5% step change in ammonium load in the influent						
No cascade	$9.30\ 10^{-3}$	$4.1\ 10^{-3}$	–	$1.95\ 10^{-6}$	15.1	–
Cascade	$6.31\ 10^{-3}$	2.51	0.040	$1.58\ 10^{-6}$	16.6	0.210

5. Conclusions

The pH and DO concentration for SHARON were determined for an optimal TNO_2/TNH ratio of 1.3 in order to feed a downstream Anammox reactor. The operating conditions found were pH 7.23 and DO $1.06\ g\ m^{-3}$. For the optimised steady state, we used the closed loop disturbance gain (CLDG) as a measurement of the effect of disturbances in the reactor. Hence, two control structures

were proposed for the SHARON reactor, as a first stage in autotrophic nitrogen removal. The response to step changes in selected disturbances confirmed the CLDG results and, therefore, a cascaded decentralized structure is proposed as a suitable configuration able to supply a stable feed to an Anammox reactor.

References

- Galí, A., Dosta, J., van Loosdrecht, M.C.M. & Mata-Alvarez, J. 2007, "Two ways to achieve an anammox influent from real reject water treatment at lab-scale: Partial SBR nitrification and SHARON process", *Process Biochemistry*, vol. 42, no. 4, pp. 715-720.
- Hellinga, C., Schellen, A.A.J.C., Mulder, J.W., Van Loosdrecht, M.C.M. & Heijnen, J.J. 1998, "The SHARON process: An innovative method for nitrogen removal from ammonium-rich waste water", *Water Science and Technology*, vol. 37, no. 9, pp. 135-142.
- Hellinga, C., Van Loosdrecht, M.C.M. & Heijnen, J.J. 1999, "Model Based Design of a Novel Process for Nitrogen Removal from Concentrated Flows", *Mathematical and Computer Modelling of Dynamical Systems*, vol. 5, no. 4, pp. 351-371.
- Hovd, M. & Skogestad, S. 1992, "Simple frequency-dependent tools for control system analysis, structure selection and design", *Automatica*, vol. 28, no. 5, pp. 989-996.
- Luff, R., Haeckel, M. & Wallmann, K. 2001, "Robust and fast FORTRAN and MATLAB ® libraries to calculate pH distributions in marine systems", *Computers and Geosciences*, vol. 27, no. 2, pp. 157-169.
- Mulder, A., Van De Graaf, A.A., Robertson, L.A. & Kuenen, J.G. 1995, "Anaerobic ammonium oxidation discovered in a denitrifying fluidized bed reactor", *FEMS microbiology ecology*, vol. 16, no. 3, pp. 177-184.
- Seborg, D.E., Edgar, T.F. & Mellichamp, D.A. 2004, *Process Dynamics and Control*,
- Van de Graaf, A.A., Mulder, A., De Bruijn, P., Jetten, M.S.M., Robertson, L.A. & Kuenen, J.G. 1995, "Anaerobic oxidation of ammonium is a biologically mediated process", *Applied and Environmental Microbiology*, vol. 61, no. 4, pp. 1246-1251.
- Villadsen, J., Nielsen, J. & Liden, G. 2011, *Bioreaction Engineering Principles*, 3rd edn, Springer.
- Volcke, E.I.P. 2006, *Modelling, analysis and control of partial nitritation in a SHARON reactor*, PhD Thesis. University of Ghent.
- Volcke, E.I.P., Van Hulle, S.W.H., Donckels, B.M.R., van Loosdrecht, M.C.M. & Vanrolleghem, P.A. 2005, *Coupling the SHARON process with Anammox: Model-based scenario analysis with focus on operating costs*.