

Technical University of Denmark



Exergy Analysis of a CO2 Recovery Plant for a Brewery

Nielsen, Daniel Rønne; Elmegaard, Brian; Bang-Møller, Christian

Published in:
Proceedings of ECOS 2012

Publication date:
2012

Document Version
Early version, also known as pre-print

[Link back to DTU Orbit](#)

Citation (APA):
Nielsen, D. R., Elmegaard, B., & Bang-Møller, C. (2012). Exergy Analysis of a CO2 Recovery Plant for a Brewery. In U. Desideri, G. Manfrida, & E. Sciubba (Eds.), Proceedings of ECOS 2012

DTU Library

Technical Information Center of Denmark

General rights

Copyright and moral rights for the publications made accessible in the public portal are retained by the authors and/or other copyright owners and it is a condition of accessing publications that users recognise and abide by the legal requirements associated with these rights.

- Users may download and print one copy of any publication from the public portal for the purpose of private study or research.
- You may not further distribute the material or use it for any profit-making activity or commercial gain
- You may freely distribute the URL identifying the publication in the public portal

If you believe that this document breaches copyright please contact us providing details, and we will remove access to the work immediately and investigate your claim.

Exergy Analysis of a CO₂ Recovery Plant for a Brewery

D. R. Nielsen^a, B. Elmegaard^b, C. Bang-Møller^c

^a Technical University of Denmark, Kgs. Lyngby, Denmark, drni@alectia.com

^b Technical University of Denmark, Kgs. Lyngby, Denmark, be@mek.dtu.dk

^c Technical University of Denmark, Kgs. Lyngby, Denmark, cbm@mek.dtu.dk

Abstract:

A large number of new and old breweries around the world experience increasing energy cost associated with the production of beer. Large heating and cooling demands in the brewing process and a wide use of utilities for assisting the processes necessitate a detailed analysis of individual efficiencies for processes and the different utility plants.

One considerable utility plant is the CO₂ recovery plant, which purifies/purges the CO₂ generated in the fermentation process in order to reuse it in the brewery site or sell it to customers who demand high quality CO₂.

In the paper a detailed model of a 2000kg/h CO₂ recovery plant for a brewery is presented, which is a typical plant capacity for a large CO₂ self-sufficient brewery. The model includes all significant unit operation in the CO₂ plant and a complete mass and energy balance of it.

In order to prevent hidden loads and misleading analysis; the system is modeled as a final supplier solution, which is initially considered without heat and recovery integration even though this is commonly used.

The following steps are presented. First step introduces the process and the component appearance followed by the energy requirements and corresponding loads. Consumptions and loads are compared with an existing plant at a corresponding capacity and are validated.

Energy and exergy analysis are used in order to illustrate the performance of each individual system component of the CO₂ recovery plant.

A schematic overview of all exergy flows including destruction is presented and proves a clear understanding of the exergy inefficiencies associated with the plant.

The highly detailed and validated model enables and prepares different holistic methodologies and analyses to be used, including thermoeconomic diagnosis and optimization of plant set points.

Keywords:

Exergy analysis, Grassmann diagram, CO₂ recovery plant, utility plant.

1. Introduction

Many breweries all over the world contain a CO₂ recovery system in order to collect the generated CO₂ from the fermentation process and exploit it for the process use. Energy requirements have been investigated in several breweries in order to determine overall electric and thermal demands, e.g. using pinch analysis in order to design the optimal heat exchanger network [1]. Even manual power, such as physical human work has been converted into exergy and included in the analyses [2]. Further evaluations have presented data for exergetic inefficiencies in the various parts of the production lines and comparison with other production sites [1].

1.1 Process description

This study examines a CO₂ recovery plant in the application of a brewery. The plant capacity is 2000 kg CO₂ per hour, designed for a typical brewery in the size of 4 million hectoliter of beer per year.

The recovery process is composed of three parts: (1) compression and purification processes, (2) stripping and condensing process finally followed by (3) a pressure storage and evaporation of the CO₂ for use in the production. A cooling facility is assisting the CO₂ plant.

1.1.1 Compression and purification processes

A schematic diagram is shown in Figure 1. CO₂ is produced during fermentation of the beer and with a small overpressure it reaches the recovery plant first arriving in the foam trap which discards possible visible gas impurities such as foam generated during fermentation. Water soluble impurities (mainly alcohol) are removed in the water scrubber and the CO₂ is lead to the balloon as a buffer supplying the following two-step-compressors containing inter- and after cooler and dehumidifier. Here the CO₂ has reached a relatively high pressure close to 20bar. After the compression odours are removed in the carbon filters followed by drying the CO₂ to a dew point of -60C in the dehydrator. The carbon filters and dehydrators are regenerated by an electric heating element and by CO₂ purge gas or air.

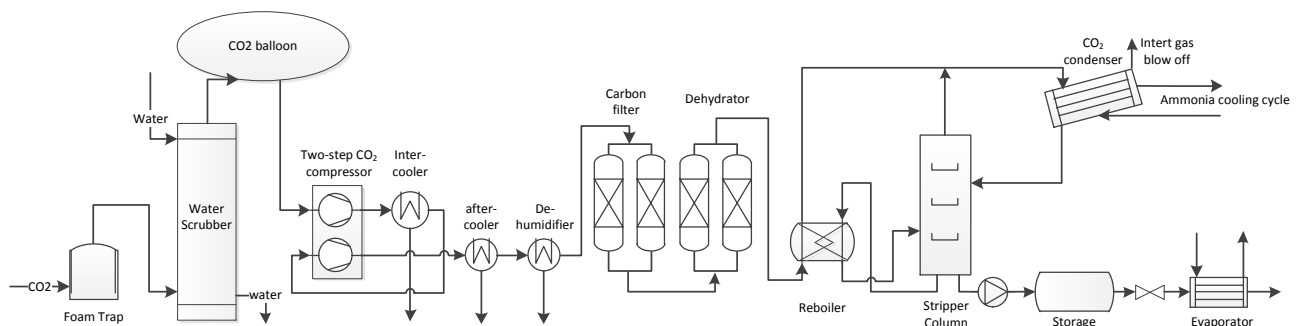

Figure 1: CO₂ compression and purification processes followed by stripping and liquefaction.

1.1.2 Stripping and liquefaction process

Purified CO₂ enters the reboiler for the stripping column in which it is precooled before liquefaction in the CO₂ condenser at temperature down to -25°C. Here the CO₂ is condensed to the reflux tank and inert gas is separated and discharged to the surroundings.

Liquid CO₂ is pumped to the top of the stripping column, where further reduction of oxygen and inert gas is obtained. From the bottom of the column liquid CO₂ is partly pumped to the storage tank and partly circulated through the reboiler which heats the column and hereby ensure continuous evaporation. For the simplest plant setup the CO₂ is finally led through a steam heated evaporator before entering the production site, which means that the cooling potential is not utilized due to time constraints.

1.1.3 Low temperature cooling facility

Figure 2 shows how the cooling demand is supplied to the CO₂ plant. An ammonia cycle supplies the CO₂ condenser and dehumidifier with cooling at two different stages, which are separated in an economizer. Heat removal from the ammonia condenser is done by a water cycle assisted with a cooling tower that furthermore supplies the inter cooler and after cooler with cooling.

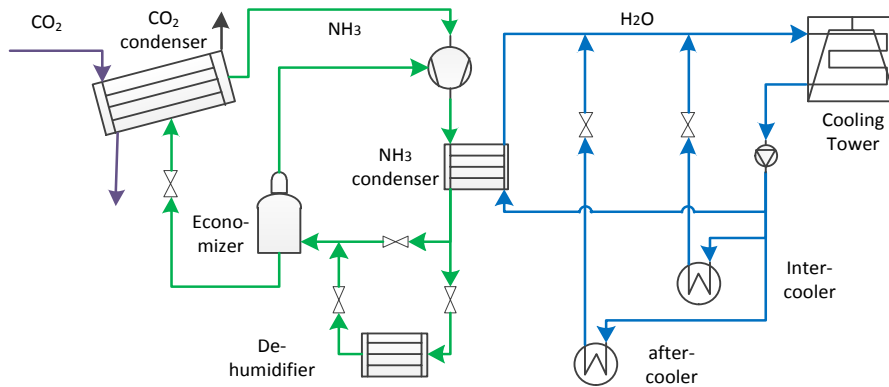

Figure 2: Cooling facility for the CO₂ liquefaction.

CO₂ process:

After component:	p [bar]	T [C]
Balloon	1,028	34,2
CO ₂ compressor step 1	4,7	192
Inter cooler	4,5	40
CO ₂ compressor step 2	18,4	186
after cooler	18,2	35
Dehumidifier	18	20
Dehydrator	17,6	19,5
Reboiler	17,6	-15
CO ₂ condenser	17,6	-23,6
Stripper column	17,6	-23,6
Storage pump	18,5	23,6
CO ₂ expansion	5	-56,5
CO ₂ evaporator	5	2

NH₃ cycle:

After component:	p [bar]	T [C]
Economizer	3	-12
CO ₂ condenser	0,95	-34,6
NH ₃ compressor	14	227
NH ₃ condenser	13	35
Dehumidifier	4	0,7

Water cycle:

After component:	p [bar]	T [C]
Pump	3	30
NH ₃ condenser	3	33
Inter cooler	3	40
After cooler	3	40
Mixing (before cooling tower)	3	34,1

Table 1: Operation states for the CO₂ recovery plant.

2. Methodology

An exergy analysis has been performed on a CO₂ recovery plant. The process setup is shown in Figure 1, while states throughout the process is shown in Table 1.

Assumptions

The following studies have been done on basis of the following assumptions:

- The system operates steady state at maximum capacity.
- Electricity consumed due to regeneration of filters is included due to a time average approach.
- Component efficiencies and heat transfer coefficients do not vary with pressure, temperature or mass flow.
- Only pressure drops in heat exchangers and filters are taken into account, while remaining pressure drops and thermal losses are neglected. E.g. heat transfer to the storage tank is neglected. This loss will cause an extra load in the CO₂ condenser, due to the fact that CO₂ gas is rejected from the tank to the condenser supply line.
- All compressors are cooled by cooling water from the same stream as for the following coolers (inter cooler, after cooler, NH₃ condenser).
- The stripping column is regenerative. It is therefore assumed that the stream out of the reboiler is pure gas and corresponds (due to mass and state) to the evaporation from the stripping column.

- It is estimated that the incoming CO₂ contains 4.2% gaseous water. Chemical exergy in the CO₂ is neglected due to the fact that its impact is less than 0.1%.

Data validation and solution procedure

Simulations have been made in DNA [3] (Dynamic Network Analysis) which is an open source simulation software [4]. It contains a list of standard components that in this case fulfills the modeling requirements.

Operating parameters, such as compressor isentropic and mechanical efficiencies, pressure drop in heat exchangers, operating states (temperatures and pressures) is all data from a specific plant setup. The simulation has been split into three parts. First part presents CO₂ containing water as a real gas in order to model the compression and condensing of water in the gaseous CO₂. Second part is a model for CO₂ as cooling media (R744) and it handles the condensing-, stripping- and evaporation process. Finally the cooling facility is modeled as an ammonia refrigeration cycle connected with a water cycle.

The stripping column is regenerative (not external heated), and therefore calculations are based on input and output data which is verified.

Exergy analysis and entropy generation

Exergy has the advantage that it valorizes energy as potential work and not only consider the mounts of energy available. An exergy analysis of the system will reveal component irreversibilities, which is an expression of entropy generation. This encourages determination of lost available work (or exergy destruction) for each component in the system and mapping of the disappearance of the work added to the system. This analysis provides a reasonable basis for optimizing the system design trough for example a thermoeconomic analysis [5].

For a system or a component only a given amount of work can be transferred to the output stream [6]. This originates in the entropy generation, of which the transferred work is given (1):

$$\dot{W} = \dot{W}_{rev} - T_0 \dot{S}_{gen} \quad (1)$$

which leads to the relation of lost work (2) (the Guoy-Stodola Theorem) [6]:

$$\dot{W}_{lost} = T_0 \dot{S}_{gen} \quad (2)$$

Entropy generation may in some cases appear a bit abstract in order to understand and present lost work. The following representation of exergy is therefore used during the execution of an exergy analysis.

Methodology for exergy analysis

All exergy transfers in inlets and outlets, E_i and E_e are calculated in the model. The exergy of the given stream refer to the maximum theoretical work that can be obtained by bringing the stream to the dead state or environmental state (T_0, p_0). Exergy flow is determined on basis of the unit-of-mass exergy [kJ/kg], so called specific exergy (3) [5]. In the case we decide to neglect chemical exergy, because of its neglectable impact, this only represents the phisycal exergy.

$$e^{ph} = (h - h_0) - T_0(s - s_0) \quad (3)$$

Destruction of exergy is calculated by the exergy balance (4):

$$\dot{E}_i = \dot{E}_e + \dot{E}_L + \dot{E}_D \quad (4)$$

In which E_L and E_D describes the loss and destruction respectively. For the major part of the components in the respective model, lost streams are not utilized and therefore included as a part of the destruction according to the system.

Destruction will be considered for each component and can be expressed in different ratios. One useful ratio is of the total destruction in the plant (5):

$$y_D^* = \frac{\dot{E}_D}{\dot{E}_{D,tot}} \quad (5)$$

Another representation of the destruction, which is used in this paper, is destruction as a ratio of total fuel input (6):

$$y_D = \frac{\dot{E}_D}{\dot{E}_{F,tot}} \quad (6)$$

This is in order to have the same reference when comparing with exergy streams relatively. For example exergy losses are likewise determined as a rate of the total fuel input (7).

$$y_L = \frac{\dot{E}_L}{\dot{E}_{F,tot}} \quad (7)$$

The final product leaves the plant as requested in the production site. The exergy content of the product stream leads to determine the overall exergy efficiency for the plant (8).

$$\eta_{II} = \frac{\dot{E}_{product}}{\dot{E}_{F,tot}} \quad (8)$$

In cases where the exergy of the final product is equal to the ambient, it may be more evident to focus on the destruction in each component in order to reduce the overall efficiency.

Grassmann diagram for CO₂ recovery plant

A Grassmann diagram shows a graphical representation of the exergy development throughout the process. The so called exergy diagram illustrates all exergetic inputs and outputs for the entire plant – both the CO₂ recovery process and cooling facility.

Exergy inputs and outputs related to the product streams, power inputs, waste streams and exergy interactions due to heat exchangers determines the destructions. All these are shown for each incorporated component in the diagram.

This exergy flow representation provides a valuable overview of the plant details which energy considerations alone cannot accommodate. It locates/pinpoint destruction of exergy and may provide better knowledge in order to improve the overall performance in a CO₂ recovery plant [7]. A Grassmann diagram of the investigated CO₂ recovery plant is shown in Figure 7.

3. Results

Energy demand for the isolated CO₂ recovery process

Figure 1 shows the energy demands for the isolated CO₂ recovery process, i.e. without the cooling facility. It appears that the total energy consumption is 767kW, contributed by cooling, heating and electricity with a share of 51.6%, 24.6% and 23.8% respectively.

The majority of electricity is consumed in the CO₂ compressors, while a minor part is consumed due to pumps and regeneration of filters.

A little more than half of the consumption is related to a cooling demand. Apparent is the cooling needed for CO₂ condensing, which contributes with 25% of the total consumption. A similar amount of cooling demand is needed in order to remove the heat generated due to the compression stages. Out of these 205kW it appears that 15% are expended on condensing water due to humidity.

After the recovery process the CO₂ is delivered to the production as gas at a reduced pressure. This expansion generates a cooling effect that has to be removed corresponding to another 25% of the total energy demand.

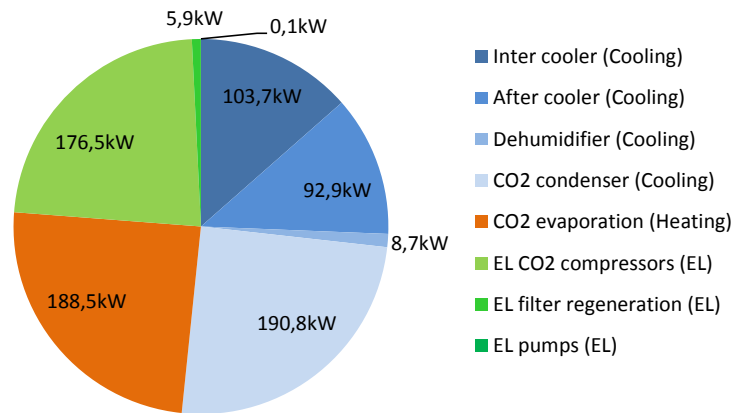

Figure 3: Energy demands for the isolated CO₂ recovery process.

Exergy expenditure in the isolated CO₂ recovery process

Converting the previous energy demand analysis into an exergy consideration of input and output exergy streams (cf. Figure 4), the following is observed:

- Total exergy input/output is 220kW.
- Electricity consumption remain unchanged, thus its share of the total consumption increases.
- The large cooling consumption for the CO₂ condenser (190.8kW) is strongly reduced to 20% (37.3kW) due to the exergy perspective.
- Cooling in the inter cooler, after cooler and dehumidifier are all above ambient temperature, which in the exergy perspective has been added to the output as a hot waste stream. Accordingly the energy flow (205kW) reduces to 9.6% (19.7kW) exergy.
- Evaporation of CO₂ is added as an output stream because of its cooling potential. This stream is also reduced (from 188.5kW energy) to 36% (67.3kW) when based on exergy.
- The CO₂ product appears to leave the plant containing 23.1% of the total exergy.
- Finally the exergy destruction occurs due to lost streams and other thermal irreversibilities. This share represent 58.9kW corresponding to 26.7% of the total output exergy.

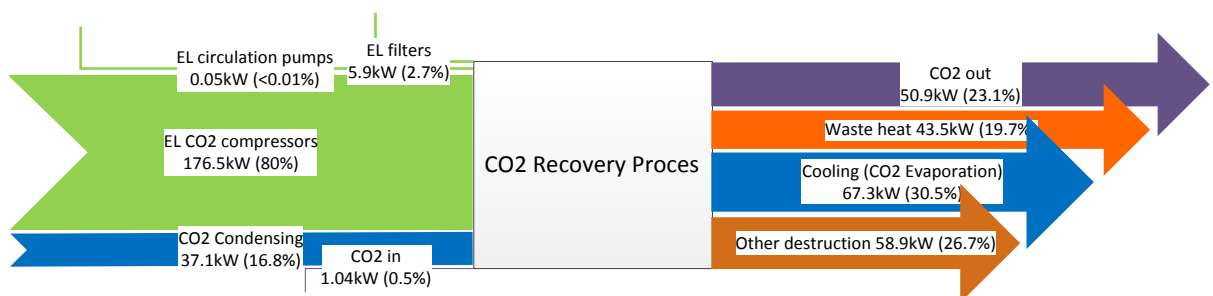

Figure 4: Exergy expenditure in the isolated CO₂ recovery process.

Energy demand for the entire CO₂ recovery plant

Considering the demand in the existing CO₂ recovery plant setup (Figure 5) the supply of cooling facility increases the consumption by 30% which results in a total energy consumption of 991kW. The heating demand remains constant while the electricity consumption is extended by an ammonia compressor of 110kW. The cooling demand keeps its share of 51%. All 507kW cooling of the plant is placed in a cooling tower.

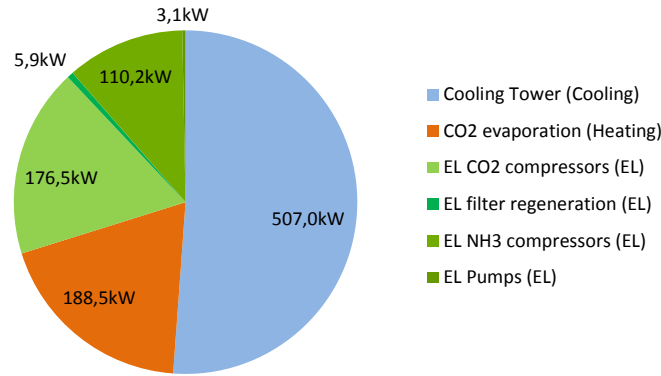

Figure 5: Energy demands for the entire CO₂ recovery plant.

Exergy expenditure for the entire CO₂ recovery plant

Figure 6 shows the input and output exergy streams for the entire plant and the following can be observed:

- Total exergy input/output is 358kW.
- Electricity still remains unchanged, but as a major part, 83% of the exergy input, while the heating demand (of 188.5kW) is replaced by steam consumption reduced to 32% (61.2kW) exergy
- The exergy output of CO₂ remains unchanged and has a share of 14.2%.
- Cooling demand of 507kW is all rejected in the cooling tower as heat just above the ambient temperature, which reduces to 2.2% (7.7kW) exergy of waste heat and becomes a part of the exergy destruction.
- Due to the steam input a small amount of 2% exergy is leaving as return condensate.
- As much as 82.6% of the exergy output disappears as thermal irreversibilities and streams that are being discharged to the environments.

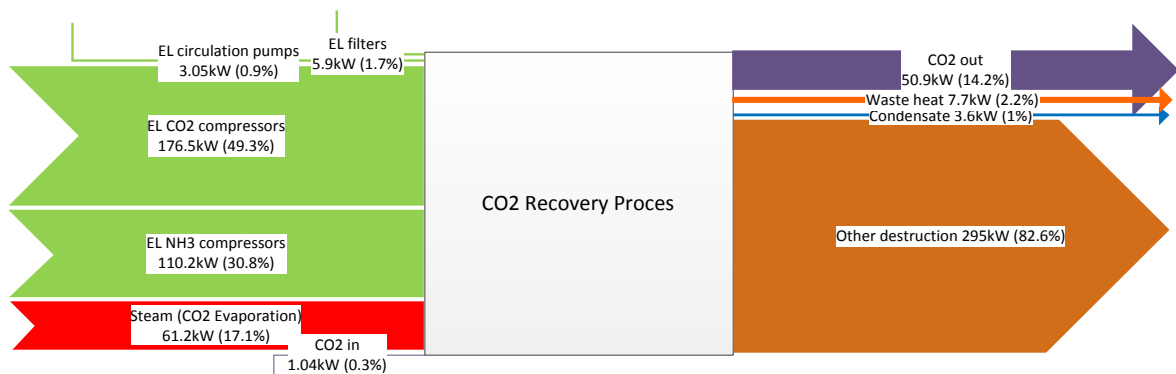

Figure 6: Exergy expenditure in the entire CO₂ recovery plant.

The consumption of the pressurized CO₂ in the production site and return of condensate to a given boiler results in an overall exergy efficiency for the CO₂ recovery plant of 0.15. However utilization of the cooling potential due to the CO₂ evaporation would increase the exergy efficiency to 0.5.

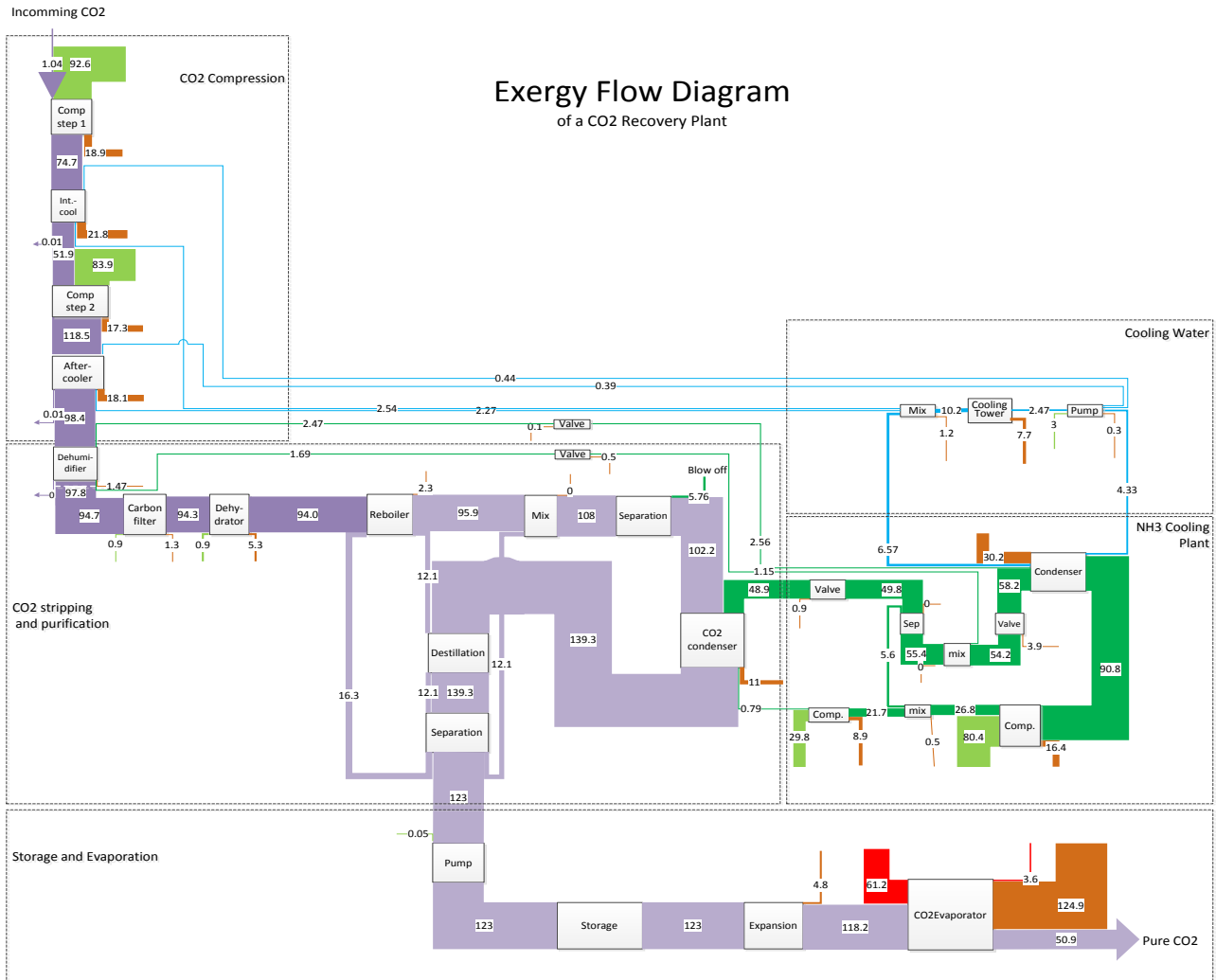

Figure 7: Grassmann diagram of the exergy flows in a CO₂ recovery plant complemented by cooling facilities.

Exergy appearance in CO₂ recovery plant in details

Figure 7 shows the exergy formation throughout the recovery plant and Figure 8 describes the exergy destruction in each single component as a ratio of the total fuel input. The following observations are made:

CO₂ process

- As long as the cooling potential due to CO₂ evaporation and the waste heat streams are not utilized, the total exergy destruction associated with the recovery plant becomes 85% (303kW), of the total fuel exergy input of 357kW.
- 35% of the input exergy is destroyed due to the CO₂ evaporation, which is a result of using steam containing a high exergy value in order to heat the low temperature CO₂ that also has high exergy content as cooling potential.
- Due to the compressor inefficiencies 10.1% of the total exergy input is destroyed.

- Waste heat after the two compression steps is generated, even though 11.2% of the exergy input is disposed by cooling water. The following dehumidifier causes another 0.4% of destruction.
- Temperature difference between NH₃ and CO₂ in the CO₂ condenser carries 3% destruction of the input exergy.
- Minor exergy destruction is the CO₂ expansion of 1.4%. Regeneration of carbon filter and dehydrator entails 1.9% and the reboiler 0.6%. Finally to be mentioned is the blow off loss stream that carry another 1.6% of the input exergy.

Cooling facility

- Inefficiencies in NH₃ compressor induces 7% destruction, while the heat generated and disposed in the NH₃ condenser carries 8.4% of the total exergy input.
- Only 2.1% is destroyed in the cooling tower in spite of the relatively large heat disposal (Figure 5). The exergy destruction connected to this large amount of energy is placed in the local heat exchange such as NH₃ condenser, inter cooler and after coolers.
- Finally some minor destructions are found due to expansion valves, pump inefficiencies and mixing of medias containing different temperature levels.

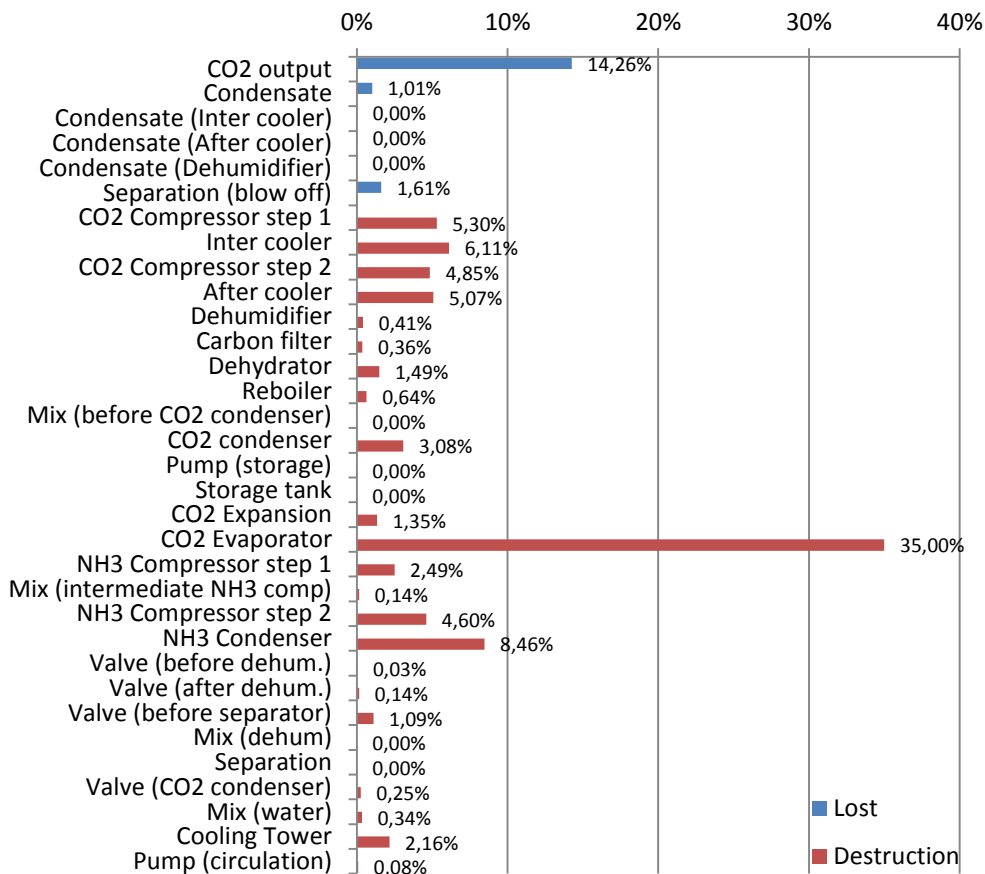

Figure 8: Exergy destruction in each component as a ratio of the total fuel input.

Evaluation of the cooling plant shows that the ammonia refrigeration cycle contributes with 200kW cooling of energy, in which 191kW and 9kW is located in the CO₂ condenser and dehumidifier respectively.

The total electricity input is 110kW which gives a COP of 1.81. Reconfiguration of temperatures may lead to less exergy destruction and therefore higher energy efficiency. By increasing the evaporation temperature both COP will increase and less exergy destruction in the evaporator (CO₂ condenser) is obtained.

The total cooling load of the entire cooling system (including the water cycle) is 396kW of energy which lead to a COP of 3.5. What is relevant to notice is the introduction of circulation of water, which transports and disposes heat from above ambient temperature to the ambient trough a cooling tower.

In order to reduce the exergy destruction the operating temperatures in the NH₃ cycle may be analyzed.

4. Discussion

The major sinner of the plant turns out to be the CO₂ evaporator that destroys 35% of the total exergy input. CO₂ should obviously not be evaporated by steam (according to an energy/exergy perspective). Apparently, the cooling potential associated with the CO₂ expansion has to be utilized. In order to exploit most of the refrigeration potential as possible, it is necessary to locate low temperature cooling demands. Since the condensing of the CO₂ involves the lowest temperature demands in the brewery the evaporation may be utilized in order to cool the CO₂ condenser – directly or indirectly. Due to time constraints between production and consumption of CO₂, it may be necessary to introduce thermal heat storage (sensible or latent).

Almost 10% of the total exergy input is destroyed due to thermal degradation in the ammonia condenser. A reduction of the condensing temperature or an exploitation of this excess heat may therefore be important in order to obtain a reduction in the total energy consumption of a brewery. Moreover, excess heat corresponding to 11.1% of the exergy input is destroyed in inter- and after cooler, of which 15% is due to condensing of water. A reduction of the water content in the incoming CO₂ will accordingly contribute in the reduction of cooling demand.

Compressor inefficiencies represent 17.1% destruction of the total exergy input, which encourage investigating the technical and economic feasibility in using more efficient compressors.

The analysis performed enables a thermo-economic analysis on the system design and further evaluation of optimal operating set points.

5. Conclusion

An analysis of energy demands for the CO₂ recovery process has been made, which gives a good foundation for determining capacities/plant dimensions for cooling facilities, heat- and power supply. The analysis has been extended by an exergy analysis in which it turns out to be more representable to illustrate some demands, such as the waste heat and cooling potential (CO₂ expansion) as output streams rather than input streams. This enables a more detailed analysis of the energy consumption and utilization through the plant.

The same has been concluded in a corresponding analysis for the entire plant setup.

An exergy analysis has been performed on a complete CO₂ recovery plant setup and presented in a Grassmann diagram in which amounts of input and output exergies are shown graphically. This presentation improves the understanding of the exergy (or value of energy) appearance in the process.

A schematic overview of all exergy output including destructions has been presented as a ratio of the total exergy input. This provides a clear understanding of the exergy inefficiencies associated with the plant – in other words a description of where the valuable energy disappear in the system.

The major contributors to the exergy destruction constitutes of the CO₂ evaporation (35% of the total exergy input), followed by the temperature degradation of generated heat due to compression of CO₂ and NH₃ and destruction associated with compression irreversibilities.

Acknowledgement

Union Engineering is acknowledged for sharing data for plant setup and operational states.

Nomenclature

\dot{e}^{ph}	physical specific exergy
\dot{E}_D	Exergy destruction
$\dot{E}_{D,tot}$	Total exergy destruction
\dot{E}_e	Exergy output
$\dot{E}_{F,tot}$	Total fuel exergy input
\dot{E}_i	Exergy input
\dot{E}_L	Exergy loss
$\dot{E}_{product}$	Exergy in product
\dot{S}_{gen}	Entropy generation
\dot{W}	Work
\dot{W}_{rev}	Reversible work
\dot{W}_{lost}	Lost work
y_D	Destruction ratio of the total input
y_D^*	Destruction ratio of the total exergy destruction
y_L	Exergy loss as ratio of the total exergy input
η_{II}	Second law efficiency

References

- [1] Muster-Slawitsch B, Brunner C, De Lima DR, Schnitzer H, Muster-Slawitsch B, Brunner C. The Green Brewery concept - Energy efficiency and the use of renewable energy sources in breweries. Chem Eng Trans 2010;21:649-54.
- [2] Fadare DA, Nkpubre DO, Oni AO, Falana A, Waheed MA, Bamiro OA. Energy and exergy analyses of malt drink production in Nigeria. Energy 2010;35:5336-46.
- [3] B. Elmegaard NH. DNA - A Thermal Energy System Simulator <http://orbit.dtu.dk/RecordLinkPage.external?sp=recid&sp=231251>. 2009.
- [4] Elmegaard B, Houbak N. Software for the Simulation of Power Plant Processes. Proceedings of ECOS 2002 2002.
- [5] Bejan A, Tsatsaronis G, Moran M. Thermal design and optimization. New York: Wiley-Interscience, 1996.
- [6] Bejan A. Advanced engineering thermodynamics. Hoboken,N.J.: Wiley, 2006.
- [7] Thomas RJ, Ghosh P, Chowdhury K. Application of exergy analysis in designing helium liquefiers. Energy 2012;37:207-19.