

Survival and Virulence of *Campylobacter* spp. in the Environment

Bui, Xuan Thanh; Bang, Dang Duong; Wolff, Anders

Publication date:
2012

Document Version
Publisher's PDF, also known as Version of record

[Link back to DTU Orbit](#)

Citation (APA):

Bui, T. X., Bang, D. D., & Wolff, A. (2012). Survival and Virulence of *Campylobacter* spp. in the Environment. Technical University of Denmark (DTU).

DTU Library

Technical Information Center of Denmark

General rights

Copyright and moral rights for the publications made accessible in the public portal are retained by the authors and/or other copyright owners and it is a condition of accessing publications that users recognise and abide by the legal requirements associated with these rights.

- Users may download and print one copy of any publication from the public portal for the purpose of private study or research.
- You may not further distribute the material or use it for any profit-making activity or commercial gain
- You may freely distribute the URL identifying the publication in the public portal

If you believe that this document breaches copyright please contact us providing details, and we will remove access to the work immediately and investigate your claim.

Survival and Virulence of *Campylobacter* spp. in the Environment

Ph.D Thesis

Xuan Thanh Bui

National Veterinary Institute
Technical University of Denmark
March 2012

Abstract

Campylobacter is the most common cause of food-borne illness in Europe, and this important zoonotic pathogen has been the focus of many research projects and scientific publications in recent years. However, we know less about the biology and pathogenicity of this pathogen than we know about many less prevalent pathogens. In this PhD project, I have investigated the survival and virulence of *Campylobacter* spp. in various matrices such as chicken faeces, swine manure and in co-culture with protozoa. In the first study, using bacterial culture and RT-qPCR methods, I found that viable *C. jejuni* cells could be detected for up to 5 days in both spiked and the naturally *Campylobacter* contaminated chicken faecal samples. Negative RT-qPCR was obtained when viable *C. jejuni* cells could not be counted by culture. In contrast, using a DNA-based qPCR method, dead or non-viable *Campylobacter* cells were detected, since all tested samples were positive, even after 20 days of storage. In the second study, the survival of *C. coli* in swine manure during storage for 30 days was studied by three different methods: bacterial culture (plate counting), DNA qPCR, and RT-qPCR. I found that *C. coli* could survive in swine manure up to 24 days at 4°C. At higher temperatures, this bacterium survived only 7 days (15°C) or 6 days (22°C) of storage. The survival of *C. coli* was extremely short (few hours) in samples incubated at 42 and 52°C. I also found that the RT-qPCR method not only can detect and differentiate living bacteria from dead cells, but also can be used to study the survival and potential pathogenicity of bacteria based on expression of different virulence genes.

In a collaborated study, I have investigated the leaching potentials of a *Salmonella* Typhimurium phage type 28B and two bacteria: *Escherichia coli* and *Enterococcus* spp., in raw slurry, in the liquid fraction of separated slurry, and in the liquid fraction after ozonation to ground water using intact soil columns models. I observed that solid-liquid separation of slurry increased the

redistribution of contaminants in liquid fraction in the soil compared to raw slurry, and the recovery of *E. coli* and *Enterococcus* spp. was higher for liquid fraction after the four leaching events. The liquid fraction also resulted in a higher leaching of all contaminants except *Enterococcus* spp. than raw slurry while the Ozonation reduced *E. coli* leaching only.

Protozoa including amoebae have been found widely in broiler houses. It has been shown that free-living protozoa may harbor, protect, and disperse bacteria, including those ingested and passed in viable form in faeces. Therefore it is very interesting to study their role in the survival of *Campylobacter*. In the second part of my PhD project, I have investigated the mechanisms involved in the interactions of *Campylobacter* and two protozoa: *Acanthamoeba castellanii* and *Cercomonas* sp. which are commonly found in soil and water. I have found that *C. jejuni* can survive intracellularly within *A. castellanii* for a short time (5 h after gentamicin treatment) at 25°C in aerobic conditions. Conversely, I found that *A. castellanii* promoted the extracellular growth of *C. jejuni* in co-cultures at 37°C in aerobic conditions. This growth-promoting effect did not require amoebae – bacteria contact. Interestingly, I identified the depletion of dissolved oxygen by *A. castellanii* as the major contributor for the observed amoeba-mediated growth enhancement.

To test whether another protozoan rather than *Acanthamoeba* has similar impacts on survival of *C. jejuni* as well as other food-borne pathogens *S. Typhimurium* and *Listeria monocytogenes*, I have investigated the interactions between a common soil flagellate, *Cercomonas* sp., and these three bacterial pathogens. I observed a rapid growth of flagellate in co-culture with *C. jejuni* and *S. Typhimurium* over the time course of 15 days. In contrast, the number of *Cercomonas* sp. cells decreased when grown with or without *L. monocytogenes* for 9 days of co-culture. Interestingly, I observed that *C. jejuni* and *S. Typhimurium* survived better when co-cultured with flagellates than when cultured alone. The results of this study suggest that *Cercomonas* sp. and perhaps other soil flagellates may play a role for the survival of these food-borne pathogens on plant surfaces and in

soil. It would be very interesting to further investigate the impacts of this soil flagellate on the survival of different food-borne pathogens in soil and in plant surface that may explain the epidemiology of recent outbreaks of food-borne diseases from vegetables.

During transmission and infection, *C. jejuni* may encounter many different stresses but little is known about how this bacterium survives and interacts with the protozoa under these conditions. I have investigated the impacts of environmental stress factors, namely heat shock, starvation, osmosis, and oxidation, on the expression of three virulence genes (*ciaB*, *dnaJ*, and *htrA*) of *C. jejuni* and its uptake by and intracellular survival within *A. castellanii*. I also investigated the mechanism(s) involved in phagocytosis and killing of *C. jejuni* by *A. castellanii*. I observed that heat and osmotic stresses reduced the survival of *C. jejuni* significantly, whereas oxidative stress had no effect. The results of qRT-PCR experiments showed that the transcription of virulence genes of *C. jejuni* was slightly up-regulated under heat and oxidative stresses but down-regulated under low nutrient and osmotic stresses, the *htrA* gene showing the largest down-regulation in response to osmotic stress. The results also showed that *C. jejuni* rapidly loses viability during its intra-amoeba stage and that exposure of *C. jejuni* to environmental stresses did not promote its intracellular survival in *A. castellanii*. In addition, the results indicated that this bacterium uses a distinct strategy for phagocytosis which involves recruiting actin for internalization in the absence of PI 3-kinase-mediated signal. The studies also identified that phago-lysosome maturation may not be the primary factor for intra-amoeba killing of *C. jejuni*. Together these findings suggest that the stress response in *C. jejuni* and its interaction with *A. castellanii* are complex and appear multifactorial.

Keywords: *C. jejuni*, *C. coli*, *L. monocytogenes*, *S. Typhimurium*, flagellate, *Cercomonas* sp., *Acanthamoeba castellanii*, manure separation, groundwater contamination, RT-qPCR, environmental stresses, virulence, chicken faeces

Dansk Resumé

Campylobacter er den hyppigste årsag til fødevarebåren sygdom i Europa, og dette vigtige zoonotiske patogen har med god grund været i fokus i mange forskningsprojekter i de seneste år. Vores viden om denne bakteries biologi og patogenitet er stadig meget begrænset i forhold til mange andre, mindre hyppigt forekommende, sygdomsfremkaldende bakterier. Formålet med dette PhD projekt har været at undersøge overlevelse og virulens af *Campylobacter* spp. i forskellige medier, så som hønse- og svine gødning, og i relation til protozoer.

I det første delprojekt, hvor vi anvendte både dyrkningsbaserede og molekylære påvisningsmetoder (RT-qPCR), fandt vi at levende *Campylobacter* celler kunne påvises i gødningsprøver i op til 5 dage, uafhængigt af om prøven naturligt indeholdt *Campylobacter* eller om de var tilsat til en negativ prøve. Dyrknings negative prøver var også negative med RT-qPCR, hvorimod vi med DNA baserede assays kunne påvise *Campylobacter* efter op til 20 dages lagring. I det andet delprojekt undersøgte vi overlevelsen af *Campylobacter coli* i svine gylle i 30 dage med tre forskellige metoder: Dyrkning, DNA qPCR, og RT-qPCR. Jeg fandt her, at *C.coli* kan overleve i svinegylle i op til 24 dage ved 4°C. Ved højere temperaturer faldt overlevelsen til 7 dage ved 15°C, og 6 dage 22°C. Overlevelsen ved 42°C and 52°C var meget kort, kun få timer. Jeg fandt i dette delprojekt, at RT-qPCR metoden både kan bruges til at skelne levende fra døde bakterier, og til at studere bakteriens overlevelse og dens potentiale for at fremkalde sygdom, målt på ekspressionen af forskellige virulens gener.

I et samarbejde med en anden forsker gruppe, har jeg, med anvendelse af en laboratoriemodel, undersøgt udvaskning til grundvandet. I forsøget anvendtes bakteriofag 28B (*Salmonella* Typhimurium) og to bakterier: *Escherichia coli* og *Enterococcus* spp, som var suspenderet i forskellige fraktioner: rå gylle, og i den flydende fraktion af separeret gylle før og efter

ozonbehandling. I den separerede gylle øgedes omfordelingen af mål organismene i den flydende fraktion i jorden, i forhold til rå gylle, og genfindelsen af *E. coli* og *Enterococcus* spp. var højere i den flydende fraktion, selv efter fire udvaskninger af jordsøjlen. Med den flydende fraktion fandtes også en højere udvaskning af *E. coli* og bakteriofag 28B end med rå gylle, medens ozonbehandling udelukkende reducerede *E. coli* udvaskningen.

Protozoer og amøber er påvist i mange slagtekyllinge huse. Det er blevet vist at fritlevende protozoer kan indeholde og beskytte bakterier, selvom de har passeret igennem en tarmkanal, og efterfølgende kan man påvise levende bakterier inde i dem. Det er derfor meget relevant at studere deres rolle for overlevelsen af *Campylobacter*. I den anden del af mit PhD projekt har jeg undersøgt mekanismer, der er involveret i interaktionen mellem *C. jejuni* og de to protozoer *Acanthamoeba castellanii* og *Cercomonas* spp., som ofte forekommer i jord og vand. Jeg fandt at *C. jejuni* kun overlever intracellulært i *A. castellanii* i en kortere periode (5 timer efter gentamicin behandling) ved 25 °C og under aerobe forhold. Men til gengæld observerede jeg at *A. castellanii* virkede fremmede på ekstracellulære vækst af *C. jejuni* når de blev dyrket i co-kultur ved 37 °C under aerobe betingelser. Denne vækst-fremmede effekt var uafhængig af amøbe – bakterie kontakt, og jeg observerede, at en af *A. castellanii*'s vigtigste bidrag til at fremme væksten bestod i at fjerne opløst ilt i mediet.

For at teste om andre protozoer har virkning på overlevelsen af fødevarebårne patogener så som *C. jejuni*, *S. Typhimurium* og *Listeria monocytogenes*, har jeg undersøgt samspillet mellem dem og jord flagellater, *Cercomonas* spp. Når flagellaten dyrkedes sammen med *C. jejuni* og *S. Typhimurium* observeredes en god vækst i løbet af 15 dage, mens antallet af flagellater faldt når den blev dyrket sammen med *Listeria monocytogenes*. Jeg observerede ligeledes at *C. jejuni* og *S. Typhimurium* også overlevede bedre, når de blev dyrket sammen med flagellaten, end når de blev dyrket alene. Resultaterne af dette tyder på, at *Cercomonas* spp., og måske andre jord flagellater

kan spille en rolle for overlevelsen af disse bakterier på planters overflade og i jord. Set i lyset af det seneste års udbrud af fødevarebårne sygdomme, vil det derfor være meget interessant at foretage yderligere undersøgelser af disse flagellaters samspil med bakterielle patogener på overfalden af planter, f.eks. grøntsager.

I forbindelse med *C. jejuni*'s optagelse og overlevelse i protozoen, udsættes den for forskellige former for stress, men vores viden om hvordan bakterien overlever og interagerer med protozoen, er meget sparsom. For at undersøge dette har jeg målt på ekspresion af *C. jejuni* tre virulensgener (*ciaB*, *dnaJ*, og *htrA*) under de miljømæssige stressfaktorer: varme, sult, osmose, og oxidation, efter optagelse i protozoen. Jeg undersøgte også de mekanismer, der er involveret i fagocytose og intracellulært drab af *C. jejuni* i *A. castellanii*. Varme og osmotisk stress reducerede overlevelsen af *C. jejuni* betydeligt, mens oxidativ stress ikke havde nogen effekt. Resultaterne af RT-qPCR forsøg viste, at transskriptionen af virulensgenerne i *C. jejuni* blev svagt opreguleret under varme og oxidative belastninger, men nedreguleres under sult og osmotisk stress; *htrA*-genet viste den største ned-regulering under osmotisk stress. Resultaterne viste også, at *C. jejuni* hurtigt taber levedygtighed i løbet af dets intra-amøbe stadie, og at udsættelsen af *C. jejuni* for miljøbelastninger, ikke fremmer dens intracellulære overlevelse i *A. castellanii*. Vi fandt desuden at *C. jejuni* tilsyneladende anvender en særskilt strategi under fagocytosen, der omfatter aktivering af aktin filamenter i fravær af et PI3-kinase-medierede signal. Undersøgelserne viste også at phagolysosomets modning ikke er den primære faktor for drab af *C. jejuni* i amøben. Sammen tyder disse resultater på, at stressresponsen i *C. jejuni* og dets interaktion med *A. castellanii* er komplekst og multifaktorielt.

Preface

This thesis is submitted in partial fulfillment of the requirements for the PhD degree at Technical University of Denmark (DTU). This work was carried out at the Laboratory of Applied Micro-Nanotechnology (LAMINATE), National Veterinary Institute, Technical University of Denmark and part at the Laboratory of Associate Prof. Dr. Carole Creuzenet, The University of Western Ontario, Canada. This project was supported by the Pathos Project funded by the Strategic Research Council of Denmark (ENV 2104-07-0015)

Acknowledgements

First and foremost, I would like to express my sincere gratitude to my advisor, senior scientist Dr. Dang Duong Bang for giving me an opportunity and continuous support of my PhD study and research, for his patience, motivation, enthusiasm, and immense knowledge. His guidance helped me in all the time of research and writing of this thesis. I could not have imagined having a better advisor and mentor for my PhD study. I also wish to specially thank my co-advisor, Associate Prof. Dr. Anders Wolff for his continuous academic and spiritual support during my entire PhD project. My advisor and co-advisor have always been there to listen and give advice. I am deeply grateful to them for the long discussions that helped me better understand the details of my work. I am also thankful to them for their constant support during my learning process of how to write an academic paper, for encouraging the use of correct grammar and consistent notation, and for carefully reading and commenting on the contents of this manuscript.

I am honored for the opportunity of spending five months of my PhD project doing research collaboration with Associate Prof. Dr. Carole Creuzenet at The University of Western Ontario (UWO), Canada. I am deeply grateful for the great support and the priceless advice I received from her during my stay at UWO. Not only was she readily available for me, but she always read and responded to the drafts of my work more quickly than I could have expected. I wish to thank to all her lab members for being helpful during my stay in her lab. My special thanks to Rachel Ford and Najwa Zebian for their comments and proofreading the manuscripts.

I would like to thank Dr. Mogens Madsen for his great support during my PhD program. I wish to thank my head of the department Dr. Flemming Bager for his support.

My thesis would not have been complete without collaboration with Dr. Anne Winding from Department of Environmental Science, Aarhus University. I wish to thank her kind support and lessons to help me work with protozoa. I wish to thank Prof. Dr. Klaus Qvortrup from Department

of Biomedical Sciences, Copenhagen University for his support and work on my Transmission Electron Microscopy techniques. I wish to thank M.G. Mostofa Amin from Aarhus University for his kind collaboration. I wish to thank Dr. Karl Petersen for his comments and proofreading of this thesis.

I owe my sincere gratitude to Jonas, Raghuram and Steen for being helpful from the first day of my Ph.D. I would like to express my sincere thanks to Dr. Cuong Cao for his comments on my manuscript. I wish to thank Lotte for her nice and kind preparation of materials for my experiments whenever I needed. I also wish to thank Annie and Lis for their help during my PhD work. Thanks to colleagues from other groups and staff members in the department of Poultry, Fish and Fur Animals for their kindness and help.

Finally, I would like to thank my entire extended family, my sisters, my brothers and friends for their constant moral support and encouragement and for believing in my abilities. Most importantly, I would like to thank my father Lap Van Bui and my mother Hoach Thi Luu, who have made me what I am today. My success in life is merely a reflection of how they have raised me. I wish to thank the ancestors of Bui's family for their blessings. Lastly I would like to thank my wife Thu Thi Nguyen for her constant support throughout all of the hard times and for being there whenever I needed her to be. You are everything I could ever ask for!

Table of Contents

Abstract	i
Dansk Resumé.....	iv
Preface.....	vii
List of publications.....	xi
List of abbreviations.....	xiii
Chapter 1: Introduction	1
1. Pathos project	1
2. Food-borne pathogens and public health.....	2
3. <i>Campylobacter</i> spp. taxonomy and general characteristics	3
4. Campylobacteriosis and clinical features of <i>Campylobacter</i> infections in humans.....	6
5. Detection and quantification of <i>Campylobacter</i> spp.....	7
5.1. Culture-based methods	7
5.2. Molecular based methods	8
6. Pathogenesis of <i>Campylobacter</i> spp.....	9
7. Stress response of <i>Campylobacter</i> spp.....	11
7.1. Heat stress	12
7.2. Starvation stress	12
7.3. Osmotic stress	13
7.4. Oxidative stress.....	14
8. Protozoa.....	15
8.1. Classification of protozoa	15
8.2. Protozoa and bacteria interactions	16
8.3. Amoeba-bacteria interactions	19
8.4. <i>Acanthamoeba-Campylobacter</i> interactions.....	22
9. Aims of the thesis	24
Chapter 2: Reverse transcriptase real-time PCR for detection and quantification of <i>C. jejuni</i>	27
Chapter 3: Fate and survival of <i>C. coli</i> in swine manure at various temperatures.....	37
Chapter 4: Survival and transport of manure-borne pathogens in soil and water	46
Chapter 5: The mechanisms involved in the interactions between <i>A. castellanii</i> and <i>C. jejuni</i>	82
Chapter 6: The impacts of a common soil flagellate on the survival of <i>C. jejuni</i> , <i>S. Typhimurium</i> and <i>L. monocytogenes</i>	97

Chapter 7: The impacts of environmental stresses on uptake and survival of *C. jejuni* in *A. castellanii* 113

Chapter 8: Summary and Outlook 165

10. References 170

List of publications

1. **Bui XT**, Wolff A, Madsen M and Bang DD (2011) “**Reverse transcriptase real-time PCR for detection and quantification of viable *Campylobacter jejuni* directly from poultry faecal samples**”. **Res. Microbiol.** Vol. **163** (1) 64-72 doi:10.1016/j.resmic.2011.10.007
2. **Bui XT**, Wolff A, Madsen M and Bang DD (2011) **Fate and survival of *Campylobacter coli* in swine manure at various temperatures.** **Front. Microbiol.** Vol. **2**:262. 1-9. doi: 10.3389/fmicb.2011.00262
3. **Bui XT**, Winding A, Qvortrup K, Wolff A, Bang DD and Creuzenet C (2011) **Survival of *Campylobacter jejuni* in co-culture with *Acanthamoeba castellanii*: role of amoeba-mediated depletion of dissolved oxygen.** **Environ. Microbiol.** doi: 10.1111/j.1462-2920.2011.02655.x (in press)
4. **Bui XT**, Wolff A, Madsen M and Bang DD (2012) **Interaction between food-borne pathogens (*Campylobacter jejuni*, *Salmonella* Typhimurium and *Listeria monocytogenes*) and a common soil flagellate (*Cercomonas* sp.). Accepted for publication**
5. M.G. Mostofa Amin, Forslund A, **Bui XT**, Juhler RK, Petersen SO and Lægdsmand M (2011) **Persistence and Leaching Potential of Microorganisms and Mineral N of Animal Manure Applied to Intact Soil Columns. Draft (ready to submit)**
6. **Bui XT**, Qvortrup K, Wolff A, Bang DD, and Creuzenet C (2012) **The effect of environmental stress factors on the uptake and survival of *Campylobacter jejuni* in *Acanthamoeba castellanii*.** Submitted

Talks and Poster presentations

1. **(Poster) Bui XT**, Merck-Jacques A, Konkel M, Dozois CM, Wolff A, Bang DD, Madsen M and Creuzenet C (2011) The Effect of Cj1294, Cj1121c and Cj1319 on Intracellular Survival and Virulence of *Campylobacter jejuni*. 16th International Workshop on Campylobacter, Helicobacter, and Related Organisms (CHRO 2011), August 28th to September 1st, 2011, Vancouver, Canada.
2. **(Talk) Bui XT**, Wolff A, Madsen M and Bang DD (2010) Fate and Survival of *Campylobacter coli* in Swine Manure at Various Temperatures. **XXXIII International Congress on Microbial Ecology and Disease, September 06-10, 2010, Athens, Greece.**
3. **(Talk) Bui XT**, Wolff A, Madsen M and Bang DD (2009) Detection and quantification of *Campylobacter jejuni* and *Campylobacter coli* mRNA in poultry fecal and swine slurry samples. 15th International Workshop on Campylobacter, Helicobacter, and Related Organisms (CHRO 2009), September 02-05, 2009, Niigata, Japan.
4. **(Poster) Bui XT**, Rruano JM, Høgberg J, Agirregabiria M, Walczak R, Dzuiban J, Bu M, Wolff A, Bang DD (2009) PCR chip and lab-on-chip systems for rapid detection and identification of *Campylobacter* spp. in broiler chicken. MED-VET-NET Annual Scientific Conference 2009, June 03-06, Madrid, Spain

List of abbreviations

AHB	Abeyta–Hunt–Bark
<i>A. castellanii</i>	<i>Acanthamoeba castellanii</i>
bp	base pair(s)
°C	degree Celsius
<i>C. coli</i>	<i>Campylobacter coli</i>
<i>C. jejuni</i>	<i>Campylobacter jejuni</i>
CFU	colony forming units
DNA	deoxyribonucleic acid
<i>E. coli</i>	<i>Escherichia coli</i>
EDTA	ethylenediaminetetraacetic acid
EC	electrical conductivity
EFSA	European Food Safety Authority
EMA-PCR	ethidium monoazide polymerase chain reaction
GBS	Guillain-Barré Syndrome
IE	irrigation event
ISO	International Organisation for Standardisation
<i>L. monocytogenes</i>	<i>Listeria monocytogenes</i>
LOS	lipo-oligosaccharide
LPS	lipopolysaccharide
LS	separated slurry
mCCDA	modified Charcoal-Cefazolin-sodium Deoxycholate-amphotericin agar
min	minutes
ml	milliliters

MRD	Maximum Recovery Diluent
mRNA	messenger Ribonucleic acid
OL	ozonated liquid
PBS	phosphate buffered saline
PCR	polymerase chain reaction
PFU	plaque forming unit
pH	potency of hydrogen
PMA-PCR	Propidium monoazide polymerase chain reaction
RNA	ribonucleic acid
rRNA	ribosomal Ribonucleic Acid
RS	Raw slurry
RT	reverse transcriptase
RT-qPCR	reverse transcriptase real-time quantitative polymerase chain reaction
ROS	reactive oxygen species
SDM	slurry dry matter
<i>S. Typhimurium</i>	<i>Salmonella</i> Typhimurium
sp.	species (plural spp.)
subsp.	Subspecies
SWC	soil water content
TOC	total organic carbon
TSA	Trypticase Soy Agar
TSB	Trypticase Soy Broth
VBNC	viable but non culturable

Chapter 1 Introduction

1. Pathos project

This PhD thesis was a part of PATHOS project. The PATHOS project was funded by the Strategic Research Council of Denmark (ENV 2104-07-0015). The project consisted of 10 different partners and led by Professor Senior scientist Carsten Suhr Jacobsen head of Microbiology laboratory, Department of Geochemistry, The Geological Survey of Denmark and Greenland (GEUS, Denmark). The project started in 2008 and ended in 2011. It is an environmental protection project. In this project the persistence, dissemination and potential threat of pathogens and estrogens leaching to Danish ground- and recreational waters will be investigated. Safe drinking and recreational waters are the expected norm in Denmark, but pathogens like *Cryptosporidium*, *Salmonella* and estrogens from pig manure have been shown to leach at high concentrations through intact clay soils (Kjær et al., 2007). The observation is not only a general environmental concern, but also a specific problem in the context of fulfilling the EU Water Frame Directive, which requires no ecotoxicological effects of substances leached to freshwaters.

Today manure is often treated by mechanical separation or additives providing a range of processed materials. The aims of the project were to study the mechanisms of controlling distribution and degradation of pathogens and estrogens in both manure and selected separation products during storage and following application to arable soil. The potential contamination of both chemicals (heavy metal, hormone etc) and microbiological materials from manure and processed manure to the ground- and recreational waters was investigated via leaching experiments and field validation, using the newly developed techniques for both identification and quantification.

This research project served as documentation of environmental technologies which could support policy development and export of Danish know-how to fight this “worldwide water quality problem

number 1". The PATHOS project was the first to study in a chain perspective on how manure separation technologies, currently under rapid development with Danish companies in the forefront, that may reduce the environmental impact of these emerging contaminants (natural estrogens and pathogens). Such knowledge will be very valuable for the industries within this area a competitive advantage and a research-based foundation for expansion and future export. The project provides a very well defined area of research linking to the quantitative detection of pathogens in environmental samples.

2. Food-borne pathogens and public health

Pathogens commonly transmitted to humans through foods and drinking water are responsible for a high burden of human illness and death worldwide. As defined by World Health Organization (WHO), food-borne illnesses are diseases, usually either infectious or toxic in nature, caused by agents that enter the body through the ingestion of food. It is difficult to estimate the global incidence of food-borne disease. However, it has been reported that in 2005 alone 1.8 million people died from diarrheal diseases and a great proportion of these cases are attributed to contaminated food and drinking water (WHO, 2007; Velusamy et al., 2010). In the United States, it was estimated 9.4 million episodes of food-borne illness yearly, resulting in 55,961 hospitalizations and 1,351 deaths (Scallan et al., 2011). In the European Union, with more than 320,000 confirmed human cases each year, food-borne diseases are also a significant and widespread public health threat (EFSA, 2011). Humans acquire these infections through a number of routes that include consuming contaminated food and water, contacting with live animals, and contaminated environment. Among these, consuming contaminated food and water is responsible for a major proportion of these infections (Pires et al., 2009).

Food-borne pathogenic microorganisms in foods may not alter the aesthetic quality of products and, thus may not be easy to assess the microbial safety of product without performing multiple microbiological tests (Mandal et al., 2011). The foods originally from animals and poultry are the most common reservoirs of many food-borne pathogens. Therefore, meat, milk, or egg products may carry *Salmonella enterica*, *Campylobacter jejuni*, *Listeria monocytogenes*, *Yersinia enterocolitica*, or *E. coli* O157:H7 (Mbata, 2005; Oliver et al., 2005b; Kang et al., 2006). Control of pathogens in raw unprocessed products at animal farms is now receiving major emphasis to reduce pathogen loads before arrival at a processing plant. The so-called “from Farm to Fork” pathogen-controlling strategies will help achieve that goal. However, the presence of pathogens in ready-to-eat (RTE) product is a serious concern since those products generally do not receive any further treatment before consumption. In fact, many recent food-borne outbreaks resulted from consumption of undercooked or processed RTE meats (hotdogs, sliced luncheon meats, and salami), dairy products (soft cheeses made with unpasteurized milk, ice cream, butter, etc.), or minimally processed fruits (apple cider, strawberries, cantaloupe, etc.) and vegetables (sprouts, lettuce, spinach, etc.) (Oliver et al., 2005b; Berger et al., 2010).

3. *Campylobacter* spp. taxonomy and general characteristics

Campylobacter species belong to the epsilon-proteobacteria (Okoli et al., 2007). Three closely related genera, *Campylobacter*, *Arcobacter* and *Sulfospirillum*, are included in the family *Campylobacteraceae* (On, 2001). *Campylobacter* species are Gram-negative, curved, S-shaped or spiral rods that are 0.2-0.9 μ m wide and 0.5-5 μ m long. They are non-spore-forming rods, usually motile by means of a single polar unsheathed flagellum at one or both ends, but may also lack flagella. They have a respiratory type of metabolism and are generally microaerophilic, requiring oxygen (3-10%) for growth but are unable to grow at normal atmospheric oxygen tensions (Park,

2002). In old cultures or when exposed to air for prolonged periods, *Campylobacter* can transform from spiral to coccoid form morphology (Griffiths, 1993).

Table 1. *Campylobacter* species, subspecies and sources of isolates

<i>Campylobacter</i> spp.	Sources of isolates	References
<i>C. jejuni</i>	Poultry, Pigs, cattle	Nachamkin et al., 2008
<i>C. coli</i>	Pigs, poultry, cattle	Gebhart et al., 1990; Nachamkin et al., 2008
<i>C. fetus</i>	Cattle, sheep	Nachamkin et al., 2008
<i>C. upsaliensis</i>	Cats, dogs, ducks, monkeys	Stanley et al., 1992
<i>C. lari</i>	Cats, dogs, chickens, monkeys, seals, mussels, oysters	Nachamkin et al., 2008
<i>C. hyointestinalis</i>	Pigs, birds, cattle, hamsters	On, 2001; Nachamkin et al., 2008
<i>C. jejuni</i> ssp. <i>Doylei</i>	Humans	Steele and Owen, 1988
<i>C. sputorum</i>	Cattle, pigs and humans	On et al., 1998
<i>C. curvus</i>	Humans	Tanner et al., 1984
<i>C. concisus</i>	Humans	Tanner et al., 1981
<i>C. insulaenigrae</i>	Marine mammals (seals and porpoise)	Foster et al., 2004
<i>C. rectus</i>	Oral flora of humans	Vandamme et al., 1991
<i>C. showae</i>	Human oral cavity	Etoh et al., 1993
<i>C. gracilis</i>	Human oral cavity	Vandamme et al., 1995
<i>C. lanienae</i>	Pigs	Sasaki et al., 2003
<i>C. helveticus</i>	Cats and dogs	Stanley et al., 1992

<i>C. mucosalis</i>	Pigs	Lawson et al., 2001
<i>C. hominis</i>	Human gastrointestinal tract	Lawson et al., 2001
<i>C. canadensis</i> sp. nov.	Birds	Inglis et al., 2007
<i>C. volucris</i> sp. nov.	Birds	Debruyne et al., 2010a
<i>C. subantarcticus</i> sp. nov.	Birds	Debruyne et al., 2010b
<i>C. peloridis</i> sp. nov.	Humans and molluscs	Debruyne et al., 2009
<i>C. cuniculorum</i> sp. nov.	Rabbits	Zanoni et al., 2009
<i>C. avium</i> sp. nov.	Poultry	Rossi et al., 2009
<i>C. troglodytis</i>	Chimpanzees	Kaur et al., 2011

Currently it has been reported that there are 17 validly named species in the genus *Campylobacter* (Fitzgerald and Nachamkin, 2007; Lastovica and Allos, 2008) and several new species were found as listed in Table 1 (Nakari, 2011). It has been shown that *C. jejuni* ssp. *jejuni*, *C. coli*, *C. fetus* ssp. *fetus*, *C. upsaliensis*, *C. lari* and *C. hyointestinalis* ssp. *hyointestinalis* are recognised as causes of intestinal infections in humans. Furthermore, *C. jejuni* ssp. *doyley* (Fernández et al., 1997), *C. sputorum* biovar *paraureolyticus* (On et al., 1998), *C. curvus* (Abbott et al., 2005), *C. concisus* (Engberg et al., 2000) and *C. insulaenigrae* (Chua et al., 2007) have been reported to associate with intestinal infections, but their pathogenic role is not clearly understood. It also has been reported that *C. rectus*, *C. concisus*, *C. curvus*, *C. showae* and *C. gracilis* are mainly considered to be the causes of oral or dental infections in humans (Etoh et al., 1993; Macuch and Tanner, 2000; Han et al., 2005), whereas *C. helveticus*, *C. mucosalis*, *C. hominis* and *C. lanienae* have not been defined to associate with human illness (Stanley et al., 1992; Lawson et al., 2001; Inglis et al., 2005; Chaban et al., 2010).

4. Campylobacteriosis and clinical features of *Campylobacter* infections in humans

Campylobacteriosis is an infection caused by the *Campylobacters* - most commonly *C. jejuni* - and an important public health problem worldwide. The disease is caused by consumption of *Campylobacter* contaminated undercooked foods, water and dairy products (Figure 1); or by direct contact with puppies and pet. It has been reported that poultry and poultry products are significant risk factors. The clinical symptoms can be severe, mild or even nonexistent that include fever, abdominal cramp, and diarrhea (with or without blood or white blood cells) that is usually self-limiting and last from several days to more than a week (Fitzgerald and Nachamkin, 2007) but relapses may occur in 5-10% of untreated patients. Post-infection complications include reactive arthritis and *C. jejuni* infection has been implicated as a trigger of Guillain-Barre´ Syndrome (GBS) (Yuki, 2001). The incidence of reactive arthritis after *Campylobacter* infection has been reported to be 1-5% (Pope et al., 2007). Cases of post-infectious irritable bowel syndrome have also been reported (Spiller, 2007). The frequency of arthritis following infection with *Campylobacter* is probably low. However, there is no correlation between the severity of gastrointestinal symptoms and the development of GBS (Allos and Blaser, 1995). Large outbreaks of campylobacteriosis are relatively rare, but implicated sources have been identified as contaminated raw milk and untreated surface water (Fitzgerald and Nachamkin, 2007; Bhunia, 2008).

Although the infective dose of *C. jejuni* has not been clearly defined, two oral doses of 500 (Robinson, 1981) and 800 cells (Black et al., 1988) have been reported in two experimental infections in volunteer humans. The molecular mechanisms involved in the pathogenesis of campylobacteriosis are still poorly understood. *C. jejuni* and *C. coli* are the most common causes of human campylobacteriosis. It is estimated about 90% of the isolates from human campylobacteriosis are identified as *C. jejuni* and most of the remaining cases are identified as *C.*

coli, but other *Campylobacter* species, for example *C. lari*, *C. upsaliensis*, *C. fetus* and *C. concisus*, have also been associated with human campylobacteriosis cases (Skirrow et al., 1993; Lindblom et al., 1995; Wiedmann and Zhang, 2011).

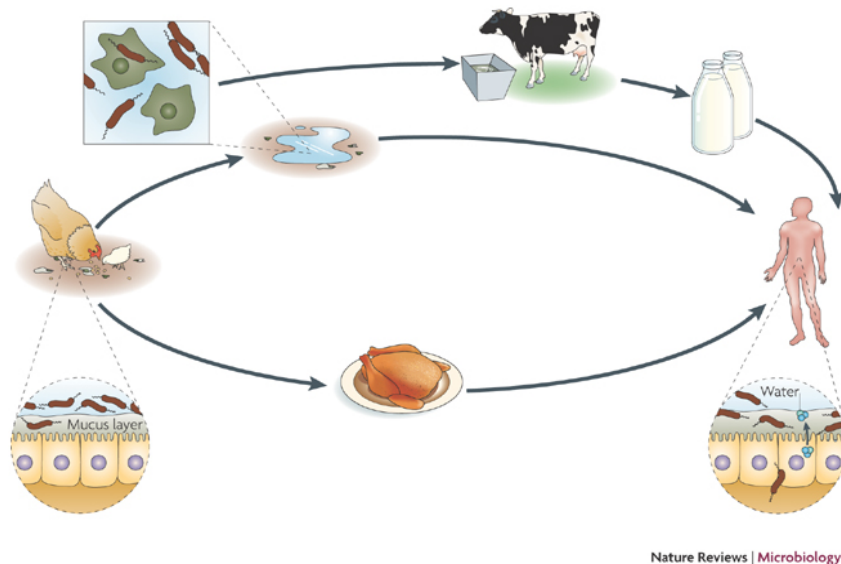

Figure 1: **Transmission routes and reservoirs of *Campylobacter* spp.** Several environmental reservoirs can lead to human infection by *C. jejuni*. It colonizes the chicken gastrointestinal tract in high numbers, primarily in the mucosal layer, and is passed between chicks within a flock through the faecal–oral route. *C. jejuni* can enter the water supply, where it can associate with protozoans, such as freshwater amoebae, and possibly form biofilms. *C. jejuni* can infect humans directly through the drinking water or through the consumption of contaminated animal products, such as unpasteurized milk or meat, particularly poultry. In humans, *C. jejuni* can invade the intestinal epithelial layer, resulting in inflammation and diarrhea (Young et al., 2007).

5. Detection and quantification of *Campylobacter* spp.

5.1. Culture-based methods

Detection and isolation of *Campylobacter* spp. are usually performed by direct plating on selective media or by enrichment followed by cultivation on solid selective media. The enrichment step may be required if the bacteria are present in very low numbers or have been damaged by environmental stresses (Corry et al., 1995). Conventional methods for *Campylobacter* spp. detection in food, faecal

samples as well as environmental samples involve culturing in selective media such as modified Charcoal Cefoperazone Deoxycholate agar (mCCDA) with selective supplement SR0155 or Abeyta-Hunt-Bark (AHB) agar with triphenyltetrazolium chloride (+TCC) at 42 °C under microaerophilic conditions according a Nordic standard protocol (Rosenquist et al., 2007). Although these methods are sensitive and are being continuously improved, they are relatively complex and time-consuming (4 to 6 days), and difficult since phenotypic identification schemes for *Campylobacter* spp. are often difficult to interpret (On, 2001). Furthermore, the bacteria cannot grow on the selective culture media if they are stressed and/or being in viable but non-culturable (VBNC) state (Corry et al., 1995).

5.2. Molecular based methods

Recent development of molecular-based methods such as PCR-based, immune-PCR, hybridization and DNA microarray methods offer the advantages of short assay times and the ability to identify *Campylobacter* spp. at species level. A majority of these methods has been developed for rapid detection in animal production or food chains with focus on poultry and poultry products, reflecting the importance of these foods as a source of human *Campylobacter* infections (Bang et al., 2004; Keramas et al., 2004; Botteldoorn et al., 2008). PCR-based and real-time PCR (RT-PCR) are continuously improving for their application in rapid detection, identification and quantification of *Campylobacter* spp. in clinical diagnostics, in food and in animal production to gain advantages in speed and sensitivity over conventional bacterial culture methods (Lund et al., 2004; Debretsion et al., 2007; Rönner and Lindmark, 2007; Ridley et al., 2008). The quantitative PCR (qPCR) is faster and more sensitive than conventional PCR and the method provides real-time data without an end-point gel electrophoresis analysis (Valasek and Repa, 2005). However, the major limitation of the

DNA-based qPCR method is the potential detection of both live and dead (Wolffs et al., 2005; Flekna et al., 2007).

It is strongly believed that the presence of bacterial messenger RNA (mRNA) is correlated with cell viability (Sheridan et al., 1998; Rijpens et al., 2002; Coutard et al., 2005; Liu et al., 2010). A reverse transcription quantitative real-time PCR (RT-qPCR) method in which mRNA is targeted instead of DNA has greater potential for detecting viable cells (Maurer, 2006). Moreover, targeting mRNA may reduce the possibility of false-positive samples in determination of viable cells because the half-life of bacterial mRNA (few hours) is much shorter than that of DNA (days or months). Previously, mRNA was used to detect and quantify viable *Campylobacter* in water, but a long procedure (12 h) was required (Lin et al., 2009).

It has been reported that propidium monoazide PCR (PMA-PCR) and ethidium monoazide PCR (EMA-PCR) can detect and quantify viable *C. jejuni* in complex samples (Rudi et al., 2004; Josefsen et al., 2010). In this thesis a method for detecting of *C. jejuni* directly from chicken faecal samples based on reversed transcriptase PCR (RT-qPCR) was developed (chapter 2). The advantage of the developed method (RT-qPCR) using mRNA as a biomarker is that not only it can be used for detection and quantification of *C. jejuni*, but also it can be used to study the survival and the potential pathogenicity of bacteria in terms of expression of virulence genes during storage of chicken faeces (Bui et al., 2012).

6. Pathogenesis of *Campylobacter* spp.

The pathogenesis of *Campylobacter* includes adhesion to intestinal cells, colonization of the digestive tract, and invasion (Young et al., 2007; Hu et al., 2008). For invasion, the ability to enter and to survive within nonphagocytic cells is thought to be very important for pathogenesis of *C. jejuni*. It has been reported that chemotaxis and motility enabled by flagella probably have

important roles in both the commensal and pathogenic lifestyles of *C. jejuni* and flagella may also have a role in adhesion (Young et al., 2007). Several proteins have been implicated to have a role in the various steps of the pathogenesis process, including outer membrane protein CadF (Krause-Gruszczynska et al., 2007), surface-exposed lipoprotein JlpA (Jin et al., 2001), secreted protein CiaB (Konkel et al., 1999), cytolethal distending toxin (Young et al., 2007), and a regulatory protein (FliK) (Kamal et al., 2007). *C. jejuni* cells produce a polysaccharide capsule (Young et al., 2007) that is important for the adhesion and invasion of epithelial cells, and for serum resistance. Unlike most other Gram-negative enteric pathogens, *C. jejuni* does not express lipopolysaccharide (LPS) but produces lighter-weight lipo-oligosaccharide (LOS). LOS differs from LPS by lacking an O-polysaccharide chain and has greater structural diversity in the outer core. Mutations in LOS biosynthesis genes affect serum resistance, adherence and invasion (Fry et al., 2000). It has also been shown that *htrA* gene of *C. jejuni* is required for heat and oxygen tolerance and for optimal interaction with human epithelial cells (Brøndsted et al., 2005; Baek et al., 2011a). It has been reported that mutations in the *cadF*, *dnaJ*, *pldA*, and *ciaB* genes impair the ability of *C. jejuni* to colonize the cecum, the chicks tolerate massive inoculation with these mutant strains, and such inoculations do not provide biologically significant protection against colonization by the parental strain (Ziprin et al., 2001). It has been shown that the CiaB protein enhances invasion of eukaryotic cells (Konkel et al., 1999; Li et al., 2008) while HtrA degrades and prevents aggregation of periplasmic proteins that misfold during stress (Laskowska et al., 1996; Li et al., 1996). DnaJ aids in protein folding and plays a role in *C. jejuni* thermotolerance and in chicken colonization (Konkel et al., 1998; Ziprin et al., 2001). A prior study reported that transcription of *dnaJ* is up-regulated upon temperature stress (Stintzi, 2003). Although little is known about the pathogenesis of *C. coli*, it has been shown that CeuE of *C. coli*, which contains a signal peptidase II site and is lipophilically modified, is likely to function as a siderophore-binding protein in a binding-protein-

dependent (PBT) system for enterochelin uptake. To have a better understanding of the survival of *Campylobacter* spp. and their potential pathogenesis in chicken faecal sample as well as pig manure under various temperatures and storage conditions, two different studies have been conducted in this thesis (chapter 2 and chapter 3).

7. Stress response of *Campylobacter* spp.

During the transmission and infection, *Campylobacter* spp. encounter many different stresses such as oxidation, heat shock, osmosis, and starvation; only the bacteria that survive in these deleterious stresses can reach the hosts (chicken and human beings). Thus, the ability of *C. jejuni* in stress resistance can be considered an important factor associated with food safety. Compared with other enteric bacteria, such as *Salmonella* spp. and *Escherichia coli*, relatively little is known about the mechanisms that allow *Campylobacter* spp. to survive in the environment. Regarding survival mechanisms, although the sequence of *C. jejuni* NCTC 11168 provides few clues, as the organism's capacity for regulating gene expression in response to environmental stress factors appears to be very limited to compare with other bacteria (Park, 2002; Murphy et al., 2006). Furthermore, many key regulators of the stress defense systems found in *Salmonella* spp. and *E. coli* are not present in *C. jejuni* (Park, 2002).

The absence of the commonly occurring survival mechanisms appears to make this bacterium ill-suited to survive outside the host and can be described as a microbiological paradox. However, *Campylobacter* spp. have been reported to survive in water, at low temperature, for up to 4 months (Rollins and Colwell, 1986; Buswell et al., 1998), during food processing (Cools et al., 2005), in chicken faeces, swine manure (Bui et al., 2011a; Bui et al., 2012) and in the environment generally (Park, 2002). Therefore, it seems the survival mechanisms of *Campylobacter* other than those commonly found in other microorganisms may be important.

7.1. Heat stress

Considerable variation in heat resistance of *Campylobacter* spp. has been observed (Murphy et al., 2006). Using a whole-genome DNA Microarray, Stintzi et al (2003) detected an up-regulation of protease genes (*lon*, *clpB*, *hslU*) and chaperone genes (*groEL*, *groES*, *grpE*, *dnaK*, *dnaJ*) in response to a temperature increase from 37 to 42°C. Following heat shock (43-48°C), at least 24 proteins are synthesized (Konkel et al., 1998), some were identified as GroELS, DnaJ, DnaK and Lon proteases (Thies et al., 1999). *C. jejuni* lacks regulatory factors that dominate heat shock response in other Gram-negative bacteria like σ^{32} and σ^E in *E. coli* (Alter and Scherer, 2006). Three alternative regulator mechanisms are proposed: RacRS regulon, a two-component regulator system – responsive to temperature and colonization-and orthologues of HrcA and HspR (Alter and Scherer, 2006).

7.2. Starvation stress

The ability of *C. jejuni* to survive in nutritionally poor environments is particularly critical in case of waterborne transmission, which despite the organism's fastidious laboratory culture requirements, is a major source of larger-scale *C. jejuni* outbreaks (Auld et al., 2004; Schuster et al., 2005). Starvation is a stress and results in a distinct physiological response such as entering into a slow-growth state with low metabolic activity directed to production of degradative enzymes (proteases, lipases) or substrate-capturing enzymes (Moore, 2001) with concomitant reduction in cell volume and physiological changes. *C. jejuni* uses a stringent response to carbon limiting nutrient stress *in vivo* and outside a host (Gaynor et al., 2005). The stringent response causes the cell to modulate gene expression and allocate resources from growth and division to amino acid synthesis (Gaynor et al., 2005). Starvation may change the morphology and physiology of *C. jejuni* cells. However, the lower metabolic activity of 5-h-starved culture was not a dormant state, but

probably a viable but non-culturable (VBNC) form of the cells, since starved *C. jejuni* induced heat stress resistance (Klancnik et al., 2009). Hong et al. (2007) suggested that *Campylobacter* in chickens can be stressed, starved, dead, or in a viable-but nonculturable state. It therefore may be starved in the storage of chicken faeces and swine manure as well. However, the mechanism of how this bacterium can survive under starvation stress is not well defined.

7.3. Osmotic stress

Campylobacters are much less tolerant to osmotic stress than other bacterial food-borne pathogens (Alter and Scherer, 2006). Resistance to high osmolarity is important mechanism for survival of bacteria including *Campylobacter* during food processing, in certain aquatic environments, and in faecal matter (Alter and Scherer, 2006). Since *C. jejuni* can be transmitted via faecal contamination of food (Drozd et al., 2011) it should overcome the osmotic stress. Jackson et al. (2009) reported that *C. jejuni* can grow at 42°C in the presence of 0.5-1.5% (w/v) NaCl, but higher concentrations ($\geq 2.0\%$ w/v) will decrease the culturability. At 42°C with a high osmotic stress, the decrease in *C. jejuni* cell numbers mirror a decaying logarithmic curve (Doyle and Roman, 1982; Abram and Potter, 1984). Although a role for the heat shock and lipooligosaccharide gene *htrB* in osmotic shock survival has been proposed (Phongsisay et al., 2007), relative little is known about this phenomenon in *C. jejuni*. It has been indicated that *C. jejuni* requires polyphosphate (poly-P) for both growth and survival during osmotic stress, most acutely (i) when the organism must grow from isolated single bacterium into colonies and (ii) during later growth stages in broth culture, where poly-P levels were shown to rise dramatically in wild-type but not the $\Delta ppk1$ mutant (Candon et al., 2007). Since the genetic response of *C. jejuni* to high and low osmotic environments has not been well established, further research for a better understanding of transport system regulation is needed.

7.4. Oxidative stress

As a microaerophilic pathogen, *Campylobacter* spp. must adapt to oxidative stress and the toxic products produced by oxygen metabolism during its cycle of transmission and infection. In order to survive in chicken faeces or pig manure through a long storage period as well as during the spreading of chicken faeces or swine manure to a field for soil fertilization, *Campylobacter* spp. also have to overcome the oxidative stress. In order to survive under aerobic conditions, the bacterium must own mechanisms to facilitate the removal of reactive oxygen species (ROS) such as superoxide anions (O_2^-), peroxides (RO_2) and hydroxyl radicals (OH). The ROS have the ability to damage DNA, protein and lipids, so the bacterial cells attempt to remove or to convert these products before they cause significant damage (van Vliet et al., 2002). It is well defined that superoxide removal is mediated by superoxide dismutases, whereas peroxides are removed by catalase, alkyl hydroperoxide reductase, thiol peroxidases and cytochrome peroxidase (Jackson et al., 2009). In addition, *C. jejuni* is also exposed to ROS produced by the host immune system and by microflora of the host intestinal tract (Mayer-Scholl et al., 2004). The microorganisms have therefore developed special and inducible defense mechanisms to protect themselves against oxidative stress (Storz and Zheng, 2000; Palyada et al., 2009). Various factors are known to mediate oxidative stress resistance in *C. jejuni*, that include SodB (superoxide dismutase), KatA (catalase), AhpC (alkyl hydroperoxide reductase), Dps (DNA-binding protein from starved cells), the multidrug efflux pump CmeG, and PerR (Kelly, 2001; Jeon et al., 2011). Furthermore, it has been reported that *C. jejuni* can adapt to the environmental oxidative stress in the host and modulate the oxidative stress within the host intestinal epithelial cells during adherence, invasion, and intraepithelial survival, allowing this bacterium to translocate into the sub-epithelial mucosa (Pogačar et al., 2009).

8. Protozoa

8.1. Classification of protozoa

Free-living protozoa are unicellular eukaryotic microorganisms that range in size between 2 and 2000 μm . For simplicity, they are generally divided according to the morphology of their locomotion organelles, with flagellates possessing flagella, ciliates, cilia, and amoebae pseudopodia (Patterson et al., 1996; Parry, 2004). This classification serves as a broad indicator of the protozoan life-style and although it does not represent true phylogenetic relationships, it is widely used in studies where such information is relevant (Moreno, 2008).

Flagellates possess one or more long, slender flagella used to swim amongst plankton, to attach to a surface and to produce feeding currents drawing prey closer for ingestion (Parry, 2004; Moreno, 2008). They multiply by binary fission and some species possess cyst stages. Flagellates are generally small (2 - 20 μm), which limits the range of prey that they can consume, sometimes resulting in each prey being treated individually (Parry, 2004; Moreno, 2008). Ciliates on the other hand, are larger and can consume more than one prey at a time, and in some systems have been shown to account for 100 % of protozoan bacterivory (Sherr et al., 1987). They use their cilia to swim in the plankton, crawl on surfaces or, in the case of the sessile stalked ciliates, to produce feeding currents (Parry, 2004). Free-living amoebae range in size from 15 to 50 μm depending on the species. They use their pseudopodia to move over a surface by projecting them and following with the rest of the cell body, and also to trap and enclose their prey in a food vacuole prior to digestion (Parry, 2004; Moreno, 2008).

Protozoa can be found in most aqueous environments and thus are in contact with a wide variety of bacteria both in the plankton and in biofilms (Matz and Kjelleberg, 2005). Transient protozoa are mostly found in the plankton; they feed on suspended bacteria but can swim close to the biofilm. Sessile protozoa are found attached to surfaces and also feed on suspended bacteria. Browser

protozoa are free-swimming and can feed both on planktonic and attached bacteria, while amoebae are found associated with surfaces and therefore can only feed on attached bacteria (Parry, 2004; Moreno, 2008). This type of classification is useful in systems where the interaction of protozoa with attached and planktonic bacterial communities is being studied.

8.2. Protozoa and bacteria interactions

It has been reported that a variety of human pathogens can be transmitted orally by water (Schoenen, 2002) and fresh produce such as vegetables, fruits, and salads (Berger et al., 2010). The central role of protozoa, which are characteristically phagotrophic in aquatic food webs and in anoxic sediment, is firmly established (Snelling et al., 2006). One of the main reasons why bacteria-protozoa interactions have attracted attention is that they represent the oldest interactions between prokaryotic and eukaryotic organisms, and as such, studying these interactions may provide an insight into how bacteria relate to other eukaryotes (Moreno, 2008). Protozoa and bacteria co-exist in most soil and aquatic environments and, therefore, this type of relationships are relevant to a variety of functioning systems. For example, protozoan grazing is one of the main selection pressures faced by the bacteria in aquatic systems and as such, it has resulted in the rise of various defense mechanisms in the latter to avoid being grazed (Moreno, 2008). A better understanding of these mechanisms would give an insight into the development of traits such as pathogenicity and multicellularity in bacteria (Matz and Kjelleberg, 2005). Additionally, in the cases where bacteria are successfully grazed by protozoa, a deeper understanding of how nutrients flow through these bacteria-protozoa food webs would clarify the role of the grazers in environmentally important processes (Greub and Raoult, 2004; Huws et al., 2005; Thomas et al., 2010).

Bacteria live in harsh environments, characterized by a constant competition for nutrients and the menace of protozoan predators. These evolutionary pressures shaped complex bacterial defense

strategies and the necessity to establish new replicative niches. To protect themselves from predators, some bacteria form inedible filaments or produce biofilms thus preventing engulfment and phagocytosis, others develop mechanisms to survive microbiocidal activities, or replicate within and kill protozoa (Matz and Kjelleberg, 2005; Hilbi et al., 2007). Protozoa are primordial phagocytes, which share many features with mammalian phagocytes, particularly macrophages. By fine-tuning their interactions with protozoa, bacteria might become also resistant to bactericidal mammalian macrophages and thereby cause disease in humans (Figure 2). Accidentally, the environmental protozoa act not only as filter for virulence traits of intracellular growth within macrophages, but also serve as protective reservoir in the form of intact amoebae or expelled vesicles, that facilitate the transmission of infectious agents to humans (Greub and Raoult, 2004; Molmeret et al., 2005; Hilbi et al., 2007).

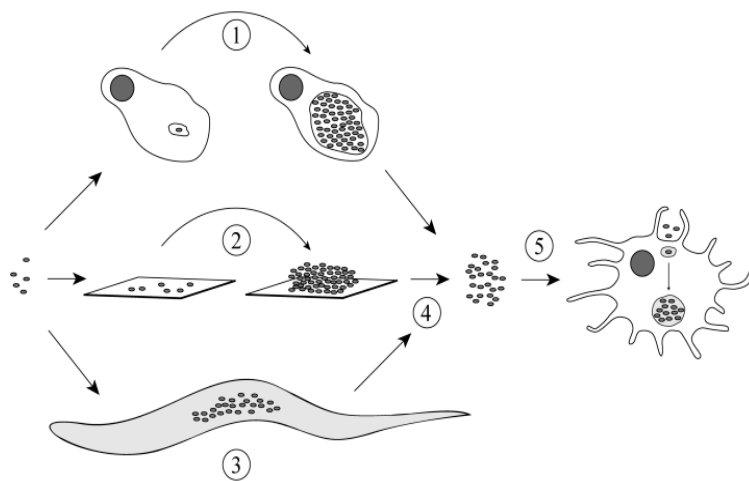

Figure 2. **Environmental niches of pathogenic bacteria and infection of macrophages.** Pathogenic bacteria (1) infect and replicate within amoebae and other protozoa, (2) colonize surfaces and grow in biofilms, (3) infect and kill nematodes, and (4) are released from their replicative niches. (5) After transmission, the pathogens infect macrophages of the innate immune system of metazoan organisms. Growth within amoebae affects the physiology and the virulence of pathogenic bacteria and may be a prerequisite to infect macrophages. A given pathogenic bacterium uses specific, conserved strategies to infect and kill various evolutionary distant eukaryotic hosts, including protozoa, nematodes, insects and mammals (Hilbi et al., 2007).

In soil, it has been shown that protozoa are important grazers of bacteria (Ekelund and Rønn, 1994). The grazing activity of protozoa stimulates bacterially mediated processes such as mineralization (Deruiter et al., 1993; Ekelund and Rønn, 1994) and nitrification (Griffiths, 1989; Verhagen et al., 1993) and can change the composition of bacterial communities in soil (Griffiths et al., 1999; Ronn et al., 2002). Although the mechanisms that lead to a change in bacterial communities as a result of protozoan predation are not clear, several studies from aquatic systems have shown that protozoa may feed selectively on different bacteria according to their size (Lekfeldt and Rønn, 2008). In addition, protozoa can discriminate between different food items and therefore only ingest some bacterial strains. Hence, protozoa graze different taxonomic groups of bacteria differently (Matz et al., 2004; Pedersen et al., 2011), however, still relative little is known about the process how protozoan selects which bacteria they can ingest and hence digest. With respect to the grazer, feeding behavior is affected by different factors such as nutritional status, metabolic state, environment and feeding strategy. The metabolic state of the grazer has been shown to affect its feeding preferences in a number of studies. For example, it was found that starved flagellates retained latex beads inside their food vacuoles for significantly longer periods than their non-starving equivalents (Boenigk et al., 2001). Further, starving flagellates fed at higher rates during the first five minutes of being in contact with bacterial prey, than their exponential-phase counterparts. Similarly, another study found that starved amoebae fed at higher rates than satiated amoebae (Xinyao et al., 2006). It was suggested that this might be due to differences in digestion potential, since starved amoebae contain no food in vacuoles therefore have more spaces to accommodate new particles and has also probably accumulated more digestive enzymes ready to be used (Xinyao et al., 2006). In addition to the metabolic state of the grazer, the environment in which the protozoa live, can affect their feeding preferences. Boenigk et al. (2001) found that pre-culturing flagellates on a particular bacterium increased their feeding rates on that same bacterium after a

starvation period. It is probably because the flagellates were used to handling that particular prey. Experiments using amoebae isolated from different vertebrate hosts, showed that the amoebae from the same host had similar feeding preferences, even if they were unrelated taxonomically (Wildschutte and Lawrence, 2007). These results suggest a phenotypic convergence of the amoebae, as a response to the conditions in their particular environment.

8.3. Amoeba-bacteria interactions

Free-living amoebae can be widely found in various environmental matrices such as soil and water, which harbor many bacteria (Schuster, 2002; Marciano-Cabral and Cabral, 2003; Khan, 2006). Amoebae grow and multiply as phagotrophic trophozoites and encyst under unfavorable conditions (Khan, 2006). Trophozoites seem to adhere preferentially to and exert their predatory activity at interfaces (water–air, water–soil, and water–plants) and successful colonization of a particular ecological niche will be determined by several environmental factors such as pH, temperature, oxygen, nutrients available and, importantly, the amount and the type of potential prey (Rodríguez-Zaragoza, 1994; Hahn and Höfle, 2001; Matz and Kjelleberg, 2005). At the trophozoite - the metabolically active stage, amoeba feeds on bacteria and multiplies by binary fission. The cyst is double-walled, and a highly resistant dormant stage that remains viable (and infective) for several years (Aksozek et al., 2002), which facilitates spreading and colonization of new ecological niches (De Moraes and Alfieri, 2008). Generally, the cyst form has two layers: the ectocyst and the endocyst. A third layer, the mesocyst, is present in some species. This structure may explain why the cysts are resistant to biocides used for disinfecting bronchoscopes (Greub and Raoult, 2003), contact lenses (Zanetti et al., 1995; Borazjani et al., 2000; Hughes and Kilvington, 2001) as well as to chlorination and sterilization of hospital water systems (Rohr et al., 1998).

Bacteria have been described as benefiting from interactions with free-living amoebae (Thomas et al., 2010). The particular interests are human pathogens which are able to survive within amoebae. The ability of survival within amoebae may give these bacterial pathogens benefits due to (1) their ability to escape predation and grow inside the protozoan that would normally phagocytose and digest; (2) their ability to resist intracellular digestion (intracellular survival, with the possible subsequent survival within a protozoan cyst); and (3) their ability to resist the protozoa digestion but also to grow within the protozoan vegetative form (trophozoite; intracellular multiplication) (Thomas et al., 2010).

The interactions between bacteria and protozoa have gained significance when Rowbotham (1980) first discovered that *Legionella pneumophila* could multiply within *Acanthamoeba polyphaga* (Rowbotham, 1980). Since then the *L. pneumophila* has been intensively studied in interactions with free-living protozoa. It has been reported that intracellular growth in *A. castellanii* has enhanced the virulence of *L. pneumophila* (Cirillo et al., 1999). A number of other pathogenic bacteria have also been reported to survive or replicate within *Acanthamoeba* species such as *Burkholderia cepacia* (Marolda et al., 1999), *Chlamydomonas pneumoniae* (Essig et al., 1997; Horn et al., 2000), *E. coli* O157 (Barker et al., 1999), *Mycobacterium avium* (Cirillo et al., 1997), *Listeria monocytogenes* (Ly and Muller, 1990). However, in the case of *L. monocytogenes*, the intracellular replication of this bacterium as reported by Ly and Muller (1990) has not been demonstrated by others (Huws et al., 2008; Akya et al., 2010). In many cases, it has proved difficult to distinguish between saprophytic growth of bacteria in co-culture with protozoa and the actual intracellular multiplication. Table 1 shows some of these amoeba-bacteria interactions.

As mentioned above, amoebal cysts have a high degree of resistance to environmental and chemical stresses and some bacterial species have been shown to survive within amoeba cysts (Thomas et al., 2010).

Table 2. Examples of pathogenic bacteria associated with protozoa, modified from (Snelling et al., 2006).

Bacteria	Protozoan host	Comments
<i>Legionella</i> spp.	<i>Acanthamoeba</i> spp. and <i>Hartmanella</i> , <i>Naegleria</i>	An intracellular parasite that causes lysis of the hosts. Responsible for legionellae in water systems.
<i>Mycobacterium avium</i>	<i>Acanthamoeba</i> spp.	Replicates in amoebae and survival within cyst walls, which may help to maintain the organism in the environment.
<i>Mycobacterium marinum</i>	<i>Dictostelium discoideum</i>	Survival and replication may help to maintain the organism in the environment
<i>Vibrio cholera</i>	<i>Acanthamoeba</i> and <i>Naegleria</i> spp.	The protozoa increases the survival of <i>V. cholera</i> in microcosms, <i>V. cholera</i> also survives within cysts of <i>Naegleria</i> .
<i>Pseudomonas aeruginosa</i>	Amoeba spp., e.g. <i>Acanthamoeba</i> spp. and <i>Dictostelium</i>	<i>Acanthamoeba</i> from a contaminated hospital water system exhibited natural infections with <i>P. aeruginosa</i> .
' <i>Candidatus Parachlamydia acanthamoeba</i> '	<i>Acanthamoeba</i> spp.	An obligate intracellular parasite of <i>Acanthamoeba</i> closely related to <i>Chlamydia</i> spp.
<i>Listeria monocytogenes</i>	<i>Acanthamoeba</i> spp.	Ingested bacteria survive and multiply in FLA.
<i>Escherichia coli</i> O157	<i>Acanthamoeba</i> spp.	Ingested bacteria survive and multiply in <i>Acanthamoeba</i> spp.
<i>Francisella tularensis</i>	<i>Tetrahymena pyriformis</i>	Replication in the host and might help to maintain the bacterium in endemic water basins.
<i>Chlamydia</i> spp.	<i>Acanthamoeba</i> spp.	Intracellular pathogens isolated from nasal mucosa.
<i>Campylobacter jejuni</i> and <i>C. coli</i>	<i>A. castellanii</i> and <i>Tetrahymena pyriformis</i>	Significant increased disinfection resistance and significant decline in bacterial viability
<i>Helicobacter pylori</i>	<i>A. castellanii</i>	Aerobic replication at low temperature
<i>Salmonella</i> spp.	<i>Acanthamoeba rhyodes</i>	Replication in the host and disinfection protection
<i>Coxiella burnetii</i>	<i>A. castellanii</i>	Replication in the host
<i>Simkania negevensis</i>	<i>Acanthamoeba polyphaga</i>	Replication in the host
<i>Yersinia enterocolitica</i>	<i>A. castellanii</i> and <i>Tetrahymena pyriformis</i>	Increased disinfection resistance when internalized.
<i>Shigella sonnei</i>	<i>A. castellanii</i> and <i>Tetrahymena pyriformis</i>	Increased disinfection resistance when internalized.
<i>Burkholderia cepacia</i>	<i>Acanthamoeba polyphaga</i>	Internalized bacterial replication

Thus the evidence is important with regard to human health because the use of chemical disinfection would not inactivate these pathogens. A number of publications has been reported that *Mycobacteria* (Adékambi et al., 2004; Thomas and McDonnell, 2007), *Francisella tularensis* (Abd et al., 2003; El-Etr et al., 2009), *L. pneumophila* (Kilvington and Price, 1990), *Vibrio mimicus* (Abd et al., 2010) and *Vibrio cholerae* (Thom et al., 1992) can survive within amoebic cysts.

8.4. *Acanthamoeba-Campylobacter* interactions

It has been reported that *Campylobacter* is rarely detected in broiler chickens less than 2 to 3 weeks of age under commercial production conditions (Sahin et al., 2003), although newly hatched chickens can be experimentally infected with *C. jejuni* (Young et al., 1999; Sahin et al., 2001). Many studies have been conducted to understand how *Campylobacter* is spreading and transmission to broiler chickens (Sahin et al., 2003). Although the routes of transmitted of *C. jejuni* are likely to be complex with many possible sources for a given poultry farm, there are more compelling evidence that horizontal transmission is the most probable route of poultry infection by *C. jejuni*, rather than vertical transmission (Shanker et al., 1986; Sahin et al., 2003; Nguyen, 2011).

It has been shown that the horizontal transmission route involves important potential sources such as poultry sheds, feeds, fauna, old litter, contaminated footwear and clothing of farmers, untreated drinking water (Ramabu et al., 2004; Nguyen, 2011), other farm animals such as cattle, sheep, pigs (Ogden et al., 2009), wildlife species such as waterfowl (Van Dyke et al., 2010), or insects such as flies (Sproston et al., 2010) and beetles (Templeton et al., 2006; Wales et al., 2010). In short, the transmission route of *C. jejuni* in animal primary production as well as how *C. jejuni* colonizes new poultry flocks is complex.

As mentioned above, broiler houses may acquire *C. jejuni* by various routes. One of the possible routes of infection is via contaminated drinking water. It has been reported that many protozoa

including amoebae, are found in water at poultry farms (Baré et al., 2011). Since it is well known that amoebae interact with bacteria, providing them protection from harsh environmental conditions (Greub and Raoult, 2004; Thomas et al., 2010), the question is whether *Acanthamoeba* may interact with *C. jejuni*. Several studies have shown that *C. jejuni* has a prolonged survival in co-culture with *Acanthamoeba* compared to planktonic *C. jejuni* and that *C. jejuni* is able to grow under aerobic conditions during co-culture with *Acanthamoeba* spp. (Axelsson-Olsson et al., 2005; Snelling et al., 2005; Axelsson-Olsson et al., 2010a; Baré et al., 2010). A recent study has found that internalized *C. jejuni* in *A. castellanii* can colonize chicks (Snelling et al., 2008).

It has been reported that *Acanthamoeba* spp. can take up and harbor *Campylobacter* (Axelsson-Olsson et al., 2005; Snelling et al., 2005). *C. jejuni* is a microaerophilic bacterium and it cannot replicate planktonically under atmospheric oxygen conditions (aerobic conditions) and below 30°C (Park, 2002) - these conditions are often found in the drinking water of poultry houses (Snelling et al., 2008). *Campylobacter* was also found to be able to persist for a longer period of time in co-culture with *Acanthamoeba* spp. at lower temperatures ranging from 4°C to 10°C compared to planktonic *Campylobacter* under the same conditions (Axelsson-Olsson et al., 2010a). Interestingly, it has been shown that at 37°C, *Campylobacter* can survive and grow in co-culture with *Acanthamoeba* in aerobic conditions (Axelsson-Olsson et al., 2007; Axelsson-Olsson et al., 2010a) and *Campylobacter* internalized within *Acanthamoeba* are able to colonize chickens (Snelling et al., 2008), suggesting that *Acanthamoeba* could act as a significant reservoir of *Campylobacter* infection (Nguyen, 2008). In addition, Axelsson-Olsson et al. (2010b) reported that *Acanthamoeba* can increase the survival of *C. jejuni* under acidic conditions as there was an increase in *Campylobacter* motility as well as increase in adhesion/internalization of *Campylobacter* within *Acanthamoeba* at pH 4 to pH 5. Since acidified water is often used in poultry rearing practices, these findings could highlight the importance of protozoa as a potential epidemiological vector of

Campylobacter infection in broilers (Nguyen, 2008). Furthermore, the protozoan internalized *Campylobacter* was shown to be more resistant to free chlorine than the planktonic bacteria at (25°C, the temperature at which reared broilers are maintained (Snelling et al., 2005; Snelling et al., 2008). These may explain the previous observations that *C. jejuni* colonization of broilers remains unaffected by chlorination of the broiler drinking water (Stern et al., 2002).

Altogether, the results from these studies suggest that *Acanthamoeba* species that live in the broiler water supplies could protect *Campylobacter* from the stressful environment of atmospheric oxygen and water chlorination treatments. This persistence could make *Acanthamoeba* a potential vector that allows *Campylobacter* to spread through water sources such as rivers and streams until a compatible host, such as poultry, is encountered. However, there was no clear evidence to indicate that *C. jejuni* could survive and replicate within *Acanthamoeba* spp. Furthermore, the fact that *Acanthamoeba* can promote the survival and multiplication of *C. jejuni* in co-culture in aerobic conditions but it is not known what factors involved directly in this phenomenon.

9. Aims of the thesis

Food-borne pathogens are considering the impact on society from health care costs, lost productivity, and time. Great efforts for understanding the epidemiology of the food-borne pathogens are well justified. With an incidence rate of 50 confirmed cases per 100,000 inhabitants over 17 countries in the EU in 2009 and 3868 laboratory confirmed cases in Denmark in 2007, campylobacteriosis is the most common bacterial food-borne human diarrhea illness in Denmark and in EU. The reasons for the high incidence human reported cases are not known, but a number of studies have shown that poultry, poultry products, manure, water and soil are sources of this infection. However, little is known about the survival as well as the potential pathogenesis of

Campylobacter spp. in the environments as well as the effects of the environmental factors on *Campylobacters*.

The aims of this thesis were:

- 1) To detect and to quantify directly viable *Campylobacter* in chicken fecal samples, a new method based on reverse transcriptase quantitative real-time PCR (RT-qPCR) was developed (chapter 2). The method was applied to study the survival of *C. coli* in swine manure stored at various temperatures (chapter 3).
2. To investigate the survival and fate of manure-borne pathogens in soil and water, a collaborated study with Aarhus University was conducted. Using *in vitro* intact soil column models the potential leaching of three bacteria: *Salmonella* Typhimurium phase type 28B, *E. coli* and *Enterococcus* spp. in raw slurry, in liquid fractions of separated slurry and in liquid fractions of slurry after ozonation was investigated (chapter 4).
3. Protozoa have been commonly found in broiler houses. It has been shown that free-living protozoa may harbor, protect and dispense bacteria including those ingested and passed in viable form in faeces. The possible role of protozoa in survival of *Campylobacter* spp. as well as the mechanism and factors involved in the interactions between *C. jejuni* and various protozoa such as *A. castellanii* (chapter 5) and the interaction of three different food-borne pathogens: *C. jejuni*, *S. Typhimurium* and *L. monocytogenes* with a common soil flagellate, *Cercomonas* sp. (chapter 6) were investigated.
4. Using the newly developed RT-qPCR method and *A. castellanii* as a model organism, the potential virulence of *C. jejuni* in the environment under different stress conditions as well as intracellular survival of the stress-adapted *C. jejuni* within this amoeba were studied. The effects of environmental stresses on expression of virulence genes, namely, *ciaB*, *dnaJ*, and *htrA* of *C. jejuni* and how these stresses might have impact on the interaction of *C. jejuni* with *A. castellanii* in term

of intracellular survival were investigated. And finally, the mechanisms involved in phagocytosis and intracellular killing of *C. jejuni* by *A. castellanii* using various chemical inhibitors and different techniques such as TEM, CLSM etc. were investigated (chapter 7).

Chapter 2: Reverse transcriptase real-time PCR for detection and quantification of viable *C. jejuni*

This chapter focuses on the development of method to isolate mRNA of *C. jejuni* directly from chicken fecal samples. The bacterial mRNA, then was used as a template for RT-qPCR to detect and quantify only viable *C. jejuni* in the spiked and naturally contaminated samples. The results of this work have been published at Research in Microbiology Journal.

Bui XT, Wolff A, Madsen M and Bang DD (2011) “**Reverse transcriptase real-time PCR for detection and quantification of viable *Campylobacter jejuni* directly from poultry faecal samples**”. **Res. Microbiol.** Vol. **163** (1) 64-72 doi:10.1016/j.resmic.2011.10.007

Reverse transcriptase real-time PCR for detection and quantification of viable *Campylobacter jejuni* directly from poultry faecal samples[☆]

Xuan Thanh Bui^a, Anders Wolff^b, Mogens Madsen^c, Dang Duong Bang^{a,*}

^a Laboratory of Applied Micro and Nanotechnology (LAMINATE), National Veterinary Institute (VET), Technical University of Denmark (DTU), Hangøvej 2, DK-8200 Aarhus N, Denmark

^b BioLabChip Group, DTU-Nanotech, Department of Micro and Nanotechnology, Technical University of Denmark (DTU), Bld 345 East, DK-2800 Kongens Lyngby, Denmark

^c DIANOVA, INCUBA Science Park Skejby, Brendstrupgaardsvej 102, DK-8200 Aarhus N, Denmark

Received 27 April 2011; accepted 26 September 2011
Available online 21 October 2011

Abstract

Campylobacter spp. is the most common cause of bacterial diarrhoea in humans worldwide. Therefore, rapid and reliable methods for detection and quantification of this pathogen are required. In this study, we have developed a reverse transcription quantitative real-time PCR (RT-qPCR) for detection and quantification of viable *Campylobacter jejuni* directly from chicken faecal samples. The results of this method and a DNA-based quantitative real-time PCR (qPCR) method were compared with those of a bacterial culture method. Using bacterial culture and RT-qPCR methods, viable *C. jejuni* cells could be detected for up to 5 days in both the *C. jejuni* spiked and the naturally contaminated faecal samples. We found that no RT-qPCR signals were obtained when viable *C. jejuni* cells could not be counted by the culture method. In contrast, using a DNA-based qPCR method, dead or non-viable *Campylobacter* cells were detected, and all tested samples were positive, even after 20 days of storage. The developed method for detection and quantification of viable *C. jejuni* cells directly from chicken faecal samples can be used for further research on the survival of *Campylobacter* in the environment.

© 2011 Institut Pasteur. Published by Elsevier Masson SAS. All rights reserved.

Keywords: *Campylobacter jejuni*; RT-qPCR; mRNA; Chicken faeces; *Campylobacter* survival

1. Introduction

Food-borne pathogens have considerably affected society in terms of morbidity, health care costs and lost productivity. Therefore, understanding of the epidemiology and pathogenicity of these pathogens is important (Hannis et al., 2008; Ziprin et al., 2001). It is estimated that there are approximately 9 million cases of human campylobacteriosis per year in 27 countries in EU (EU27) (Andreoletti et al., 2011). The most important sources of *Campylobacter* infection are poultry and poultry products. The bacteria are frequently

isolated during poultry production, including at rearing and slaughter, and their occurrence is well documented (Jensen and Aarestrup, 2001; Lund et al., 2004; Møller Nielsen et al., 1997). It has been estimated that about 90% of human campylobacteriosis cases are associated with *Campylobacter jejuni* (*C. jejuni*), and the majority of the remaining cases are related to *Campylobacter coli* (*C. coli*) (Gillespie et al., 2002; Hannis et al., 2008).

Conventional bacterial culture methods for detecting *Campylobacter* spp. that involve enrichment, isolation, and identification at the species level are labour-intensive and time-consuming, requiring 5–6 days to complete (Collette et al., 2008). Recently, many new molecular methods based on *Campylobacter* DNA, either by conventional or qPCR, have been developed (Lund et al., 2004; Ridley et al., 2008; Rønner and Lindmark, 2007). Quantitative real-time PCR (qPCR) is faster and more sensitive than conventional PCR

[☆] A part of this work was presented as an oral and poster presentation at the 15th International Workshop on *Campylobacter*, *Helicobacter*, and Related Organisms (CHRO2009, Niigata, Japan).

* Corresponding author. Tel.: +45 35886892; fax: +45 35886901.

E-mail address: ddb@vet.dtu.dk (D.D. Bang).

and the method provides real-time data without an end-point gel electrophoresis analysis (Valasek and Repa, 2005). However, the major limitation of the DNA-based qPCR method is the potential detection of both live and dead, or non-culturable cells (Flekna et al., 2007; Wolffs et al., 2005).

It is strongly believed that the presence of bacterial messenger RNA (mRNA) is correlated with cell viability (Coutard et al., 2005; Liu et al., 2010; Rijpens et al., 2002; Sheridan et al., 1998). A reverse transcription quantitative real-time PCR (RT-qPCR) method in which mRNA is targeted instead of DNA has greater potential for detecting viable cells (Maurer, 2006). Moreover, targeting mRNA may reduce the possibility of false-positive samples in determination of viable cells because the half-life of bacterial mRNA (in h) is much shorter than that of DNA (days or months). Previously, mRNA was used to detect and quantify viable *Campylobacter* in water, but a long procedure (12 h) was required (Lin et al., 2009). In addition, it has also been reported that bacterial mRNA isolated from faecal samples is cumbersome due to the presence of many inhibitors which can affect RT-qPCR efficiency.

Since chicken faeces and chicken caecum are the main reservoirs of *C. jejuni*, while the major source of *C. coli* is swine (Pearce et al., 2003; Rudi et al., 2004), we focused in the present study only on the detection and quantification of *C. jejuni*. RT-qPCR targeting *C. jejuni* 16S rRNA, *ciaB* and *dnaJ* mRNA was established for detection and quantification of viable *C. jejuni* cells directly from chicken faecal samples and for overcoming PCR inhibitor issues. The *ciaB* gene is recognised as an important putative factor in *C. jejuni* pathogenesis (Eppinger et al., 2004). It has been reported that the gene is highly prevalent and conserved in many *C. jejuni* isolates from various sources (Datta et al., 2003). The *dnaJ* gene is the functional homologue of the *dnaJ* gene from *Escherichia coli* and plays an important role in *C. jejuni* thermotolerance and colonisation (Konkel et al., 1998), while the 16S rRNA gene is often used in studies as an indicator of viable bacterial cells (Buswell et al., 1998; Churrua et al., 2007; Li et al., 2008).

The aims of the present study were: (1) to develop an approach enabling the detection and quantification of only viable *C. jejuni* cells directly from chicken faeces; and (2) to investigate survival of *C. jejuni* and its potential pathogenic status in chicken faecal samples during storage at room temperature.

2. Materials and methods

2.1. Bacterial strains and culture conditions

C. jejuni reference strain CCUG 11284 and two *C. jejuni* chicken isolates, SC-181 and SC-11, described previously (Bang et al., 2003), were used in this study. The strains were recovered on blood agar base No. 2 (CM271; Oxoid, Greve, Denmark) supplemented with 5% (v/v) sterile defibrinated calf blood and isolated on modified charcoal cefoperazone deoxycholate agar (mCCDA CM0739; Oxoid, Greve, Denmark) with selective supplement SR0155 (Oxoid, Greve, Denmark). The medium was prepared according to the manufacturer's instructions. A solid selective medium, Abeyta-Hunt-Bark (AHB) agar (Technical University of Denmark, DTU-Vet, Aarhus, Denmark) with triphenyltetrazolium chloride (+TCC) was used for direct determination of colony-forming units (CFUs). Chromosomal DNA of six additional *Campylobacter* strains, five *Salmonella* strains, two *E. coli* strains, one *Listeria* strain and one *Clostridium* strain (Table 2) were extracted using the QIAamp® DNA Mini-Kit (Qiagen, Copenhagen, Denmark). The DNA concentration was determined using a NanoDrop 1000 Thermo-Scientific spectrophotometer (Saveen Werner ApS, Jyllinge, Denmark). Bacterial DNA samples (2 ng/μl) were used to evaluate the specificity of the qPCR assays.

2.2. Faecal samples

Two types of faecal samples (cloacal swabs and sock samples) were used. A total number of 63 swab samples, representing 8 flocks from 4 different chicken farms, were collected. The swabs were stored in screw-capped plastic tubes and transported to the laboratory. On arrival, each swab was transferred to a tube containing 3 ml of sterile water.

A total of 40 sock samples representing 8 houses from 4 chicken farms were collected as previously described (Skov et al., 1999). Briefly, a pair of sock samples consisted of two elastic cotton bands (Tubigrip D no. 1451; Seton Healthcare Group plc, Oldham, England) approximately 20 cm long. The socks were moistened in water and pulled over the boots of the farmer. The farmer walked around the chicken house several times and the socks were turned periodically to expose the entire surface of the socks to the chicken faeces on the floor. Sock samples were put in plastic bags and transported to the

Table 1

List of primers used in this study, with their sequences, size of amplicons, genbank access numbers and references.

Target genes	Primer sequences (5'–3')	Annealing temperature (°C)	Amplicon sizes (bp)	GenBank access no.	References
<i>ciaB</i>	ATATTGCTAGCAGCGAAGAG GATGTCCCACTTGTAAGGTG	54	157	NC_002163	(Li et al., 2008)
<i>dnaJ</i>	AGTGTGCGAGCTTAATATCCC GGCGATGATCTTAACATACA	54	117	NC_002163	(Li et al., 2008)
16S rRNA	GCGTAGGCGGATTATCAAGT CGGATTTTACCCTACACCA	52	122	NC_002163	This study

Table 2
List of bacterial strains used in this study and results of DNA-based qPCR with three different primer sets.

No.	Species	Strains	DNA-based qPCR		
			<i>ciaB</i>	<i>dnaJ</i>	<i>16S rRNA</i>
1	<i>Campylobacter jejuni</i>	SC-181	+	+	+
2	<i>C. jejuni</i>	SC-11	+	+	+
3	<i>C. jejuni</i>	CCUG 11824	+	+	+
4	<i>C. coli</i>	CCUG 10955	–	–	–
5	<i>C. coli</i>	CCUG 11283	–	–	–
6	<i>C. coli</i>	CCUG 10951	–	–	–
7	<i>C. lari</i>	CCUG 19512	–	–	–
8	<i>C. upsaliensis</i>	CCUG 15015	–	–	–
9	<i>C. fetus</i> subsp. <i>fetus</i>	CCUG 6823	–	–	–
10	<i>Salmonella</i> Typhimurium	NCTC 12023	–	–	–
11	<i>S. Typhimurium</i> LT2	NCTC 12416	–	–	–
12	<i>S. Enteritidis</i>	NCTC 13349	–	–	–
13	<i>S. Enteritidis</i>	NCTC 12694	–	–	–
14	<i>S. Dublin</i>	NCTC 09676	–	–	–
15	<i>Escherichia coli</i>	NCTC 9001	–	–	–
16	<i>E. coli</i> CDT producing	E6468/62 D2253 (O127:H11)	–	–	–
17	<i>Clostridium perfringens</i>	NCTC8239	–	–	–
18	<i>Listeria monocytogenes</i>	NCTC 7973	–	–	–

NCTC strains were obtained from the National Collection of Type Cultures (London, UK).

CCUG strains were obtained from the Culture Collection of the University of Gothenburg (Sweden).

laboratory. On arrival, each sock sample was supplemented with 300 ml of sterile water and left for approximately 5 min at room temperature to release the bacteria. All samples were determined for *Campylobacter* contamination by culture (Anonymous, 2006; <http://www.iso.org>) and qPCR methods. Twenty three of the 40 collected sock samples were determined positive for *C. jejuni* and used as *Campylobacter* naturally contaminated samples. The naturally contaminated samples were stored in sterile plastic bags at room temperature (~ 22 °C) for up to 20 days. The survival of *C. jejuni* in these samples was determined using both DNA-based qPCR and RT-qPCR methods.

2.3. Spiked faecal samples

To investigate the survival of *C. jejuni* in chicken faeces at room temperature (22 °C), 40 faecal samples (30 swabs and 10 sock samples) that were *Campylobacter*-negative as determined by both culture and qPCR methods were collected and pooled. The pooled sample was divided into small portions of 90 ml in sterile plastic bags. To each portion of 90 ml, a 10 ml suspension of strain *C. jejuni* SC-181 in saline (0.9% NaCl) was added to reach a final concentration of 5×10^8 CFU/ml. The inoculated samples were stored at room temperature (~ 22 °C) for up to 20 days. This temperature was selected for testing in order to mimic the temperature of broiler houses.

2.4. Detection of *C. jejuni* by bacterial culture and qPCR methods

2.4.1. Bacterial culture method

Duplicate tenfold serial dilutions ranging from 10^0 to 10^{-8} were prepared from chicken faecal samples. In total, 100 μ l of each dilution was spread in duplicate onto AHB plates and

incubated for 48 h at 42 °C under microaerobic conditions. The selective AHB agar plates were applied according to recommendations of ISO 10272-1:2006 (Anonymous, 2006; <http://www.iso.org>). Plates were inspected to detect the presence of colonies presumed, because of their characteristics, to be *Campylobacter*. Five presumptive *Campylobacter* colonies per chicken faecal sample were picked and verified by a conventional PCR method as described in the section below.

2.4.2. Conventional PCR conditions

In an initial experiment, several colonies from a plate were picked and suspended in 100 μ l of 0.9% NaCl. Five microlitres of the bacterial suspension were used as a template for a *Campylobacter*-specific PCR reaction as previously described (Lund et al., 2003). The PCR mixtures were set up in 25 μ l volumes and PCR amplification was performed in a Peltier PTC-200 thermal cycler (MJ Research Inc., Waltham, MA, USA). PCR conditions included 1 cycle of 94 °C for 5 min, followed by 45 cycles of 94 °C for 15 s, annealing at 54 °C for 20 s extended to 72 °C for 15 s. Five microlitres of the PCR product were loaded onto a 2% agarose gel (Bio-Whittaker, Inc., Walkersville, MD, USA) containing 0.1 μ g of ethidium bromide per ml, and electrophoresis was performed at 400 V for 45 min. The gel was visualised in a GelDoc-It™ image system (UVP, Cambridge, England).

2.4.3. Quantitative real-time PCR conditions

Quantitative real-time PCR (qPCR) was performed in an Mx3005P thermocycler (Stratagene, Rødovre, Denmark) using primers listed in Table 1. PCR mixtures (25 μ l) contained 5 μ l DNA or 5 μ l cDNA, 12.5 μ l of 2 \times PCR master mix (Promega, Nacka, Sweden), 400 nM of each primer and 50,000 \times diluted SYBR green (Invitrogen, Naerum, Denmark). qPCR conditions consisted of an initial heat-denaturing step at 94 °C for

5 min followed by 45 cycles of 94 °C for 15 s, annealing at 54 °C for 20 s and extended to 72 °C for 15 s, followed by an elongation step at 72 °C for 3 min. In each qPCR analysis, the *C. jejuni* standard for absolute quantification was included in duplicate. To determine the detection limits of assays in pure culture, 1 ml volumes of PBS were inoculated with 10^0 – 10^8 CFU *C. jejuni* SC-181 from the appropriate dilution. The nucleic acids were extracted from these as described below and DNA-based qPCR and RT-qPCR assays were performed as described above. To determine the detection limits and establish the standard curve of the assays with faecal samples, we collected the faecal suspensions from 10 pooled *Campylobacter*-negative swab samples. One-millilitre volumes of *Campylobacter*-negative chicken faecal samples were inoculated with 10^2 – 10^8 CFU *C. jejuni* (SC-181) from the appropriate dilution and the DNA and RNA were extracted from these as described below. DNA-based qPCR assays were performed to produce the standard curves. A negative control (5 µl of water) and a positive DNA control (5 µl) of *C. jejuni* DNA strain SC-11 (2 ng/µl) were included.

Post-PCR amplification melting temperature (T_m) analysis from 50 to 95 °C at 0.5 °C increments was conducted to determine specific *ciaB* product ($T_m = 78$ °C), *dnaJ* product ($T_m = 80$ °C) and *16S rRNA* product ($T_m = 84$ °C). Mx3005P detection software was used to determine threshold cycle (C_t) values, T_m , and the standard curve. Negative controls included RNase- and DNase-free water and nucleic acid extracts from non-spiked faecal samples to determine any possible cross-reactivity or contamination (false-positive results).

2.5. Total bacterial nucleic acids (RNA and DNA) extraction

Total bacterial nucleic acids (RNA and DNA) were extracted from faecal samples using cetyltrimethylammonium bromide (CTAB) buffer and the lysate was used to purify mRNA using a part of the RNeasy Mini-RNA isolation kit (Qiagen, Copenhagen, Denmark) according to the manufacturer's protocol. Briefly, 1 ml of each bacterial faecal suspension was transferred to a microcentrifuge tube and centrifuged at 8000 g for 7 min. The pellets were mixed with 0.5 ml of CTAB extraction buffer, 0.5 ml of phenol-chloroform-isoamyl alcohol (25:24:1, pH 8.0) and 250 mg of zirconia/silica beads (Biospec Products Inc., Bartlesville, USA). The mixture of sample and beads was vortexed for 30 s. The lysate was centrifuged at 13,000 g for 5 min. The aqueous phase was purified by chloroform-isoamyl alcohol (24:1) extraction. The mixture was centrifuged at 13,000 g for 5 min. The volume of the aqueous phase was estimated and the nucleic acids were precipitated by adding a 0.08 volume of chilled 7.5 M ammonium acetate and a 0.54 volume of chilled isopropanol. For DNA extraction, instructions for step (a) were followed, and for RNA extraction, instructions for step (b) were followed.

- a) The tube was inverted 20–30 times to mix the components and incubated on ice for 30–40 min. The precipitated

DNA was collected by centrifugation at 13,000 g for 10 min at 4 °C. The DNA pellet was washed once using ice-cold 70% ethanol and dried by air. The DNA pellet was suspended in 50 µl of DNase-free water. The DNA preparation was used immediately or stored at –20 °C until needed.

- b) The lysate, including any precipitate that may have formed, was transferred to an RNeasy spin column placed in a 2 ml collection tube from the RNeasy Mini-RNA isolation kit (Qiagen,) and centrifuged for 15 s at 8000 g. Washing steps were followed according to the manufacturer's protocol. The RNA was eluted in 50 µl of RNase-free water and treated with 0.3 U/ml of DNase I amplification grade (Invitrogen,) according to the manufacturer's protocol. The treated RNA was further tested for DNA contamination by qPCR using the primer pairs of *ciaB*, *dnaJ*, and *16S rRNA* (Table 1). Briefly, the PCR mixtures (25 µl) contained 12.5 µl of 2× PCR master mixture (Promega), 400 nM of each primer and 50,000× diluted SYBR green (Invitrogen) and 5 µl treated RNA or 5 µl untreated RNA. The PCR procedures were the same as described above. The DNA-free RNA products were transcribed to complementary DNA (cDNA) using the iScript™ cDNA synthesis kit (Bio-Rad, Hercules, USA) with pre-mixed RNase inhibitor and random hexamer primers, according to the manufacturer's instruction.

2.6. Statistical analyses

The values were expressed as the average ± standard deviation (SD). These values were applied for quantification of *C. jejuni* in spiked samples. The data were analysed for statistical significance using one-way ANOVA (ANalysis Of VAriance, Microsoft Excel). A p -value ≤ 0.05 was considered to be statistically significant.

2.7. Experimental design

Two different samples, *C. jejuni* spiked chicken faecal samples and *C. jejuni* naturally contaminated chicken faecal samples, were included in the study.

The *C. jejuni* spiked chicken faecal samples were prepared as described above (see Section 2.3). The spiked samples were kept in sterile plastic bags and stored at room temperature. One-ml volumes of the samples were collected at days 1, 3, 5, and 7 for detection and quantification of *C. jejuni*. The numbers of *C. jejuni* in the faecal samples were determined by AHB plate counting, qPCR and RT-qPCR methods.

For the naturally contaminated faecal samples, 23 of 40 collected sock faecal samples were *C. jejuni*-positive as confirmed by both culture and PCR methods. The positive samples were wrapped in sterile plastic bags and kept in the same conditions as described above. At days 1, 3, 5, 7, 10, 15 and 20, 1 ml volumes of these samples were collected for the detection and quantification of *C. jejuni* by both qPCR and RT-qPCR methods.

3. Results

3.1. Specificity of quantitative real-time PCR assays

The specificity of the assays using three different primer sets (*ciaB*, *dnaJ*, and *16S rRNA*) was determined by qPCR assays with the DNA targets isolated from pure cultures of 18 *Campylobacter* and non-*Campylobacter* strains (Table 2). qPCR-positive results of each primer set as a single band of 157, 117 and 122-bp for *ciaB*, *dnaJ*, and *16S rRNA* genes, respectively, were observed (data not shown) when testing DNA templates from the three *C. jejuni* strains. None of the qPCR-amplified products was observed from the strains of other *Campylobacter* species or the non-*Campylobacter* strains. The specificity of the amplified products was also determined by the melting curves of the qPCR assays. As expected, we obtained the specific melting peak at 78 °C for amplified *C. jejuni ciaB* products in qPCR reactions performed with the DNA from the three *C. jejuni* strains (data not shown). Similarly, melting temperature curves with the specific melting peak at 80 °C for *dnaJ* and at 84 °C for *16S rRNA* of qPCR products from chicken faeces spiked with *C. jejuni* were observed (data not shown). None of the specific melting peaks or qPCR-amplified products of three used genes was observed when water and non-spiked faecal samples as well as DNA isolated from the other *Campylobacter* species and non-*Campylobacter* strains were used as targets, indicating that false-positive results or cross-contaminations were absent.

3.2. Determination of the sensitivity of DNA-based qPCR and RT-qPCR assays

The sensitivity of assays for detection of *C. jejuni* using three different primer sets (*ciaB*, *dnaJ* and *16S rRNA*) was determined by both qPCR and RT-qPCR using SYBR Green I and by determining the C_t values of the amplified products. By using serial dilutions of *Campylobacter* DNA and mRNA extracted from a known number of *C. jejuni*, the sensitivity of qPCR and RT-qPCR was tested as described in Materials and methods. For the pure culture, the sensitivity of the DNA-based qPCR assay was as low as 10 CFU/ml, whereas the sensitivity of the RT-qPCR assay was 100 CFU/ml. For the spiked chicken faecal samples, the sensitivity of the DNA-based qPCR assay was 100 CFU/ml, while it was 1000 CFU/ml for the RT-qPCR assay.

3.3. Standard curve for absolute quantification

To set up standard curves for the qPCR assays, DNA was extracted from 10-fold dilution series of *C. jejuni* spiked chicken faecal samples and C_t values were determined. C_t values were plotted as a function of the cell concentration and the plot showed the expected linear relationship between the \log_{10} of CFU/ml and C_t values (Fig. 1). The standard curve slopes of three primer pairs were similar, varying from -3.331 to -3.576 , corresponding to 96–100% efficiency for qPCR

assays using the formula $E(\text{efficiency}) = (10^{-1/\text{slope}}) - 1$. The curves were linear over the range tested, from 10^2 to 10^8 CFU/ml of the chicken faecal sample and limits of quantification were 3×10^2 and 10^3 CFU/ml for the DNA-based qPCR and RT-qPCR, respectively.

3.4. Survival of *C. jejuni* in spiked samples stored at room temperature

The survival of *C. jejuni* in spiked chicken faecal samples stored at room temperature was determined by bacterial culture, qPCR and RT-qPCR methods. At day 1, approximately 3.1×10^7 CFU/ml of *C. jejuni* was obtained by the culture method, while approximately 1.5×10^7 and 5×10^7 CFU/ml were obtained by the *dnaJ* qPCR and RT-qPCR, respectively (Fig. 2A). Similar results were observed for the *16S rRNA* qPCR ($\sim 6 \times 10^7$ CFU/ml) and RT-qPCR ($\sim 10^7$ CFU/ml) (Fig. 2B), while *ciaB* RT-qPCR resulted in a lower number ($\sim 10^6$ CFU/ml) than the culture method ($\sim 1.5 \times 10^7$ CFU/ml) or the qPCR method ($\sim 5 \times 10^7$ CFU/ml) (Fig. 2C).

At days 3 and 5, the number of *C. jejuni* measured by the bacterial culture method decreased steadily to $\sim 10^6$ CFU/ml and $\sim 5 \times 10^3$ CFU/ml, respectively. Similar levels of *C. jejuni* were obtained using the RT-qPCR method (Fig. 2). At day 7, a negative result was observed by both bacterial culture and RT-qPCR methods. In contrast, a high amount of *C. jejuni* ($>6 \log_{10}$ CFU/ml) was observed by the DNA-based qPCR method (Fig. 2) and all samples were positive for *C. jejuni* until day 20 of storage (data not shown).

3.5. Survival of *C. jejuni* in naturally contaminated chicken faecal samples

The survival of *C. jejuni* in naturally contaminated chicken faecal samples during storage for 7 days at room temperature was detected and quantified by both DNA-based qPCR and RT-qPCR methods. In this experiment, only *dnaJ* primers were used. At day 1, all 23 samples were positive for *C. jejuni* by both methods (Table 3). However, using the RT-qPCR method, 21 of 23 samples (91.3%) were found positive at

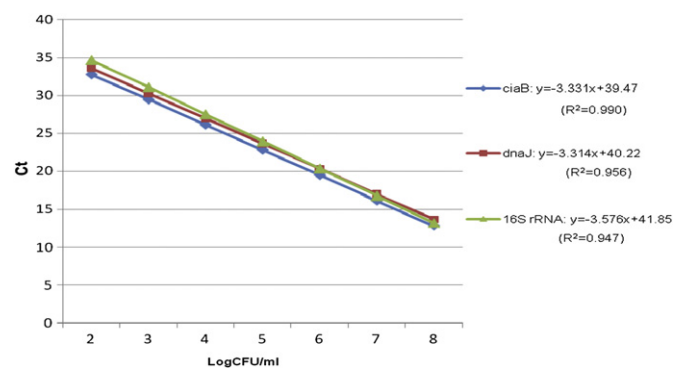

Fig. 1. The standard curve for absolute quantification. Standard curves produced from 10-fold serial dilutions ranging from 1×10^2 – 1×10^8 CFU/ml chicken faecal sample of *C. jejuni* (SC-181), showing the linear relationship between C_t and \log_{10} CFU/ml for qPCR assays. C_t , cycle threshold.

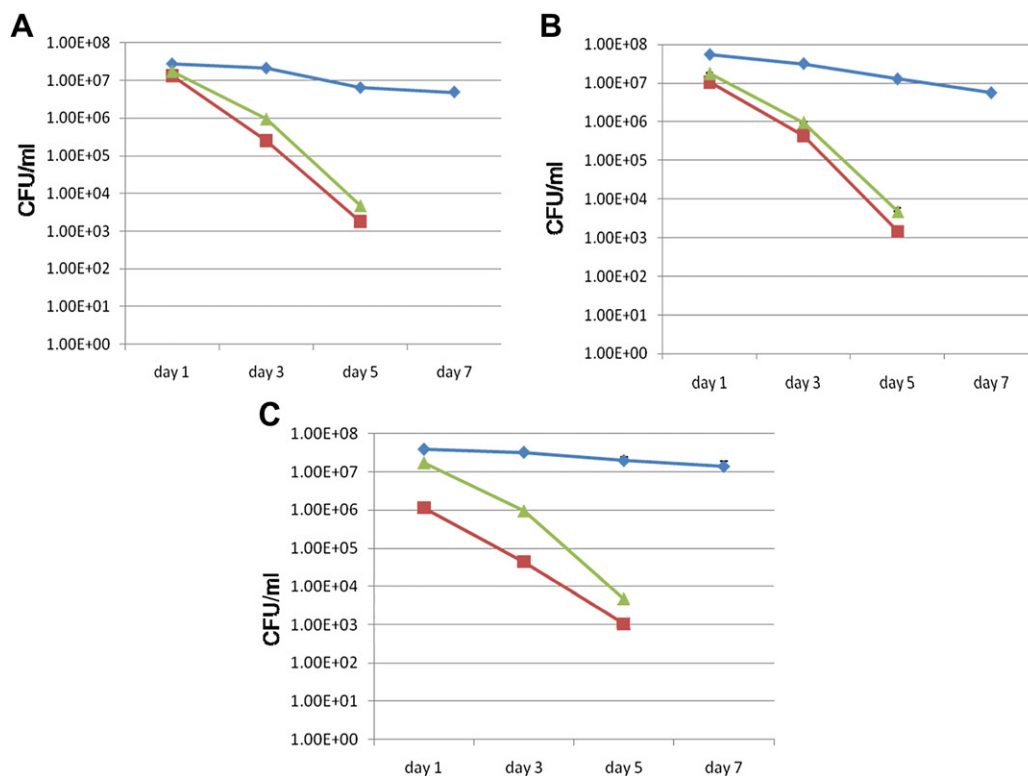

Fig. 2. Detection and quantification of *C. jejuni* in spiked faecal samples by DNA-based qPCR, RT-qPCR assays and the enumeration method on AHB (+TCC), (2A) *dnaJ* DNA, (2B) *16S rRNA*, and (2C) *ciaB* DNA of *C. jejuni* were detected by qPCR after day 7, whereas *dnaJ*, *16S rRNA* and *ciaB* mRNA of *C. jejuni* were detected by RT-qPCR assays until day 5. (■) RT-qPCR; (◆) DNA-based qPCR; (▲) enumeration of *C. jejuni* on AHB (+TCC). Data are means \pm SD of three replicate experiments.

day 3 and 10 of 23 samples (43%) were positive at day 5, while none of the 23 samples was positive at day 7. In contrast, using DNA-based qPCR assay, all 23 samples (100%) were *C. jejuni*-positive at day 7.

Quantitative data on *C. jejuni* in naturally contaminated samples at day 1 determined by RT-qPCR were in a range of 10^3 to 4×10^7 CFU/ml, whereas approximately from 10^3 to 4×10^5 CFU/ml were obtained at day 3. As shown in Fig. 3, approximately 10^3 – 6×10^3 CFU/ml were obtained by RT-qPCR assay for 10 of 23 faecal samples, while a range from 10^4 to 3×10^7 CFU/ml was obtained by DNA-based qPCR assay for all 23 faecal samples at day 5. At day 7, none of 23 chicken faecal samples was positive for *C. jejuni* by the RT-qPCR assay, but a range from 10^4 to 10^7 CFU/ml was still obtained by the DNA-based qPCR assay for all 23 samples.

4. Discussion

Real-time PCR technology has been increasingly used for detection and quantification of pathogens in food and environmental samples by targeting the DNA (Churrua et al., 2007; Lund et al., 2004; Rönner and Lindmark, 2007). A main drawback of this method is its inability to distinguish the DNA from viable cells and dead cells. It was reported that DNA from dead bacterial cells could persist for up to three weeks after cell death (Josephson et al., 1993) and that persistence could lead to an overestimation of the number of viable cells and false-positive results (Wolffs et al., 2005).

In this study, we developed an approach that allows direct detection and quantification of viable *C. jejuni* cells spiked in chicken faecal samples. The method enables simple

Table 3

The survival of *Campylobacter jejuni* in naturally contaminated fecal samples was investigated both DNA-based PCR and RT-qPCR assays.

Methods	Date of performed experiments			
	No. of samples positive at day 1 (%)	No. of samples positive at day 3 (%)	No. of samples positive at day 5 (%)	No. of samples positive at day 7 (%)
RT-qPCR (% positive)	23/23 (100)	21/23 (91.3)	10/23 (43)	0 (0)
DNA-based qPCR (% positive)	23/23 (100)	23/23 (100)	23/23 (100)	23/23 (100)

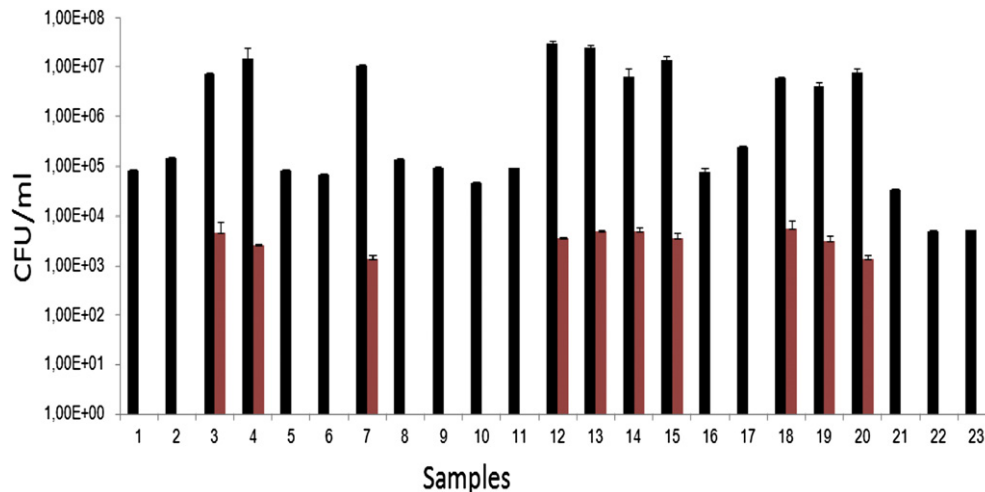

Fig. 3. Detection and quantification of *C. jejuni* in 23 naturally contaminated samples at day 5 using *dnaJ* primers by DNA-based qPCR (black bar) and RT-qPCR assays (red bar). Data are means \pm SD of duplicate experiments. (For interpretation of the references to colour in this figure legend, the reader is referred to the web version of this article.)

processing due to fewer enrichment steps. It has been reported that propidium monoazide PCR (PMA-PCR) and ethidium monoazide PCR (EMA-PCR) can detect and quantify viable *C. jejuni* in complex samples (Josefsen et al., 2010; Rudi et al., 2005). However, the advantage of our method is not only its use for detection and quantification of *C. jejuni*, but the fact that it can also be used to study the survival and potential pathogenicity of bacteria in terms of invasion and adherence to the host during storage of chicken faeces. Three *Campylobacter* genes, *ciaB*, *dnaJ* and *16S rRNA*, were selected as targets for this study. It has been shown that the *C. jejuni* genome contains three copies of the *16S rRNA* gene (Taylor et al., 1992). The gene has been widely used as a biomarker for viable bacterial cells and the presence of rRNA has been shown to be correlated with cellular viability (Churrua et al., 2007; Inglis and Kalischuk, 2004; Taylor et al., 1992). The data presented in this study showed that, using *16S rRNA* as a target for RT-qPCR, the measurement of survival of *C. jejuni* in artificially contaminated chicken faecal samples corresponds to the presence of viable cells. RT-qPCR results correspond to an absence of CFU on AHB plates at day 7 of storage by the bacterial culture method. Furthermore, we observed that the amount of *C. jejuni* in spiked samples obtained by either *dnaJ* or *16S rRNA* RT-qPCR was very close to the result obtained by the culture method. The number of *C. jejuni* obtained by *ciaB* RT-qPCR was lower than that of the culture method. This phenomenon could be explained by lower expression of the *ciaB* gene compared to *16S rRNA* and *dnaJ* genes during storage of faecal samples. We investigated the level of mRNA for *ciaB* and *dnaJ*, since these genes encode potential putative pathogenic factors which play crucial roles in colonisation ability, adhesion to intestinal cells, invasion and epithelial translocation (Konkel et al., 1998). Our data showed that the levels of mRNA for *ciaB* and *dnaJ* genes measured by RT-qPCR were highly consistent with the bacterial culture method as long as *C. jejuni* cells were viable in chicken faecal samples.

The sensitivity (10^2 CFU/ml) of the DNA-based qPCR assay was similar to results reported previously by Lund et al. (2004), where the DNA-based qPCR method was used to detect *C. jejuni* in chicken faeces, and it was similar to the detection limit of 6.6×10^2 CFU/ml as reported by Rönner and Lindmark (2007). In this study, the RT-qPCR assay (10^3 CFU/ml) had sensitivity that was one log lower than the DNA-based qPCR detection (10^2 CFU/ml). The difference in sensitivity has also been observed in other studies (Kubota et al., 2010; Techathuvanan et al., 2010). Several reasons might explain this: lower efficiency of the RNA extraction method, the shorter half-life of bacterial mRNA or the efficiency of the reverse transcription reaction.

The RT-qPCR method has been used for detection and quantification of other bacteria such as *E. coli*, *Salmonella*, and *Legionella pneumophila* (Bej et al., 1991; Liu et al., 2010; Sheridan et al., 1998; Techathuvanan et al., 2010). This study is the first to use RT-qPCR to investigate the survival of *Campylobacter* in chicken faecal samples. Furthermore, by comparing different methods, a significant difference ($p < 0.05$) between the numbers of *C. jejuni* measured by DNA-based qPCR and those measured by RT-qPCR was observed. Similar results were reported by Kubota et al. (2010) when studying the survival of *Enterococcus* and *Lactococcus* in human faecal samples (Kubota et al., 2010). Higher numbers of bacteria measured by DNA-based qPCR than those obtained by the bacterial culture method have been found in several previous studies. It was suggested that this was due to detection of DNA from dead or non-culturable cells utilising DNA-based qPCR assays (Ridley et al., 2008; Rönner and Lindmark, 2007; Wolffs et al., 2005).

In this study, viable *C. jejuni* cells could be detected for up to 5 days in chicken faecal samples stored at room temperature by either RT-qPCR method or the bacterial culture method, which is in good agreement with previously reported data (Gilpin et al., 2009; Rodgers et al., 2010). Furthermore, studying the survival of *C. jejuni* in 23 faecal samples

naturally contaminated with *Campylobacter* during a 20-day storage period at room temperature revealed that at day 1, all of the samples (23/23) tested positive for *C. jejuni* by both methods. However, a significant difference was observed between the two methods, as 91.3%, 43%, and 0% of the samples were *C. jejuni*-positive by the RT-qPCR method at day 3, 5 and 7, respectively, whereas 100% of the samples were *C. jejuni*-positive by the DNA-based qPCR method (Table 3), even after 20 days of storage. These results indicate that the DNA-based qPCR method might detect DNA from dead or non-culturable cells several weeks after the bacteria have died and that RT-qPCR, in contrast to DNA-based qPCR, could be a helpful tool for the detection and quantification of viable bacterial cells in environmental samples.

In summary, we have developed a method for the extraction, purification, and quantification of *Campylobacter* mRNA directly from chicken faecal samples. Using this method, only viable *Campylobacter* cells were detected; therefore, RT-qPCR is obviously a recommended tool for quantifying live *Campylobacter* spp. in chicken faecal and environmental samples. Using this method, accurate and reliable data for risk assessments can be achieved.

Acknowledgements

We thank Dr. Cuong Cao for his great help in editing the manuscript. We thank Jonas Høggberg for skilled technical assistance. This study was supported by the Pathos Project funded by the Strategic Research Council of Denmark (ENV 2104-07-0015).

References

- Andreoletti, O., Budka, H., Buncic, S., Collins, J.D., Griffin, J., Hald, T., Havelaar, A., Hope, J., Klein, G., McLauchlin, J., Müller-Graf, C., Nguyen-The, C., Noerrung, B., Peixe, L., Maradona, M.P., Ricci, A., Sofos, J., Threlfall, J., Vågsholm, I., Vanopdenbosch, E., 2011. Scientific opinion on *Campylobacter* in broiler meat production: control options and performance objectives and/or targets at different stages of the food chain. EFSA J. 9, 141.
- Anonymous, 2006. Microbiology of Food and Animal Feeding Stuff—horizontal Method for Detection and Enumeration of *Campylobacter* spp. British Standards Institution, London. BS EN ISO 10272-1:2006.
- Bang, D.D., Scheutz, F., Gradel, K.O., Nielsen, E.M., Pedersen, K., Engberg, J., Gerner-Smidt, P., Handberg, K., Madsen, M., 2003. Detection of seven virulence and toxin genes of *Campylobacter jejuni* and *Campylobacter coli* isolates from different sources and cytolethal distending toxin production suggest potential diversity of pathogenic properties among isolates. Genome Lett. 2, 62–72.
- Bej, A.K., Mahubani, M.H., Atlas, R.M., 1991. Detection of viable *Legionella pneumophila* in water by polymerase chain reaction and gene probe methods. Appl. Environ. Microbiol. 57, 597–600.
- Buswell, C.M., Herlihy, Y.M., Lawrence, L.M., McGuigan, J.T.M., Marsh, P.D., Keevil, C.W., Leach, S.A., 1998. Extended survival and persistence of *Campylobacter* spp. in water and aquatic biofilms and their detection by immunofluorescent-antibody and -rRNA staining. Appl. Environ. Microbiol. 64, 733–741.
- Churrua, E., Girbau, C., Martínez, I., Mateo, E., Alonso, R., Fernández-Astorga, A., 2007. Detection of *Campylobacter jejuni* and *Campylobacter coli* in chicken meat samples by real-time nucleic acid sequence-based amplification with molecular beacons. Int. J. Food Microbiol. 117, 85–90.
- Collette, F., Whichard, J., Nachamkin, I., 2008. In: Nachamkin, I., Szymanski, C.M., Blaser, M.J. (Eds.), Diagnosis and Antimicrobial Susceptibility of *Campylobacter* species, third ed. ASM Press, Washington, DC.
- Coutard, F., Pommepuy, M., Loaec, S., Hervio-Heath, D., 2005. mRNA detection by reverse transcription-PCR for monitoring viability and potential virulence in a pathogenic strain of *Vibrio parahaemolyticus* in viable but nonculturable state. J. Appl. Microbiol. 98, 951–961.
- Datta, S., Niwa, H., Itoh, K., 2003. Prevalence of 11 pathogenic genes of *Campylobacter jejuni* by PCR in strains isolated from humans, poultry meat and broiler and bovine faeces. J. Med. Microbiol. 52, 345–348.
- Eppinger, M., Baar, C., Raddatz, G., Huson, D.H., Schuster, S.C., 2004. Comparative analysis of four *Campylobacter* spp. Nat. Rev. Microbiol. 2, 872–885.
- Flekna, G., Stefanic, P., Wagner, M., Smulders, F.J.M., Mozina, S.S., Hein, I., 2007. Inefficient differentiation of live and dead *Campylobacter jejuni* and *Listeria monocytogenes* cells by ethidium monoazide (EMA) compromises EMA/real-time PCR. Res. Microbiol. 158, 405–412.
- Gillespie, I.A., O'Brien, S.J., Frost, J.A., Adak, G.K., Horby, P., Swan, A.V., Painter, M.J., Neal, K.R., 2002. A case-case comparison of *Campylobacter coli* and *Campylobacter jejuni* infection: a tool for generating hypotheses. Emerg. Infect. Dis. 8, 937–942.
- Gilpin, B.J., Robson, B., Scholes, P., Nourozi, F., Sinton, L.W., 2009. Survival of *Campylobacter* spp. in bovine faeces on pasture. Lett. Appl. Microbiol. 48, 162–166.
- Hannis, J.C., Manalili, S.M., Hall, T.A., Ranken, R., White, N., Sampath, R., Blyn, L.B., Ecker, D.J., Mandrell, R.E., Fagerquist, C.K., Bates, A.H., Miller, W.G., Hofstadler, S.A., 2008. High-resolution genotyping of *Campylobacter* species by use of PCR and high-throughput mass spectrometry. J. Clin. Microbiol. 46, 1220–1225.
- Inglis, G.D., Kalischuk, L.D., 2004. Direct quantification of *Campylobacter jejuni* and *Campylobacter lanienae* in feces of cattle by real-time quantitative PCR. Appl. Environ. Microbiol. 70, 2296–2306.
- Jensen, L.B., Aarestrup, F.M., 2001. Macrolide resistance in *Campylobacter coli* of animal origin in Denmark. Antimicrob. Agents Chemother. 45, 371–372.
- Josefsen, M.H., Lofstrom, C., Hansen, T.B., Christensen, L.S., Olsen, J.E., Hoorfar, J., 2010. Rapid quantification of viable *Campylobacter* bacteria on chicken carcasses, using real-time PCR and propidium monoazide treatment, as a tool for quantitative risk assessment. Appl. Environ. Microbiol. 76, 5097–5104.
- Josephson, K.L., Gerba, C.P., Pepper, I.L., 1993. Polymerase chain reaction detection of nonviable bacterial pathogens. Appl. Environ. Microbiol. 59, 3513–3515.
- Konkel, M.E., Kim, B.J., Klena, J.D., Young, C.R., Ziprin, R., 1998. Characterisation of the thermal stress response of *Campylobacter jejuni*. Infect. Immun. 66, 3666–3672.
- Kubota, H., Tsuji, H., Matsuda, K., Kurakawa, T., Asahara, T., Nomoto, K., 2010. Detection of human intestinal catalase-negative, gram-positive cocci by rRNA-targeted reverse transcription-PCR. Appl. Environ. Microbiol. 76, 5440–5451.
- Li, Y.-P., Ingmer, H., Madsen, M., Bang, D., 2008. Cytokine responses in primary chicken embryo intestinal cells infected with *Campylobacter jejuni* strains of human and chicken origin and the expression of bacterial virulence-associated genes. BMC Microbiol. 8, 107.
- Lin, S., Gilpin, B., Scholes, P., Podivinsky, E., Klena, J., Savill, M., 2009. Preliminary development and validation of a real-time reverse transcription PCR assay for the semi-quantification of viable *Campylobacter jejuni* in water samples. Water Sci. Technol. 60, 3151–3158.
- Liu, Y., Wang, C., Fung, C., Li, X.-F., 2010. Quantification of viable but nonculturable *Escherichia coli* O157:H7 by targeting the rpoS mRNA. Anal. Chem. 82, 2612–2615.
- Lund, M., Nordentoft, S., Pedersen, K., Madsen, M., 2004. Detection of *Campylobacter* spp. in chicken fecal samples by real-time PCR. J. Clin. Microbiol. 42, 5125–5132.
- Lund, M., Wedderkopp, A., Wainø, M., Nordentoft, S., Bang, D.D., Pedersen, K., Madsen, M., 2003. Evaluation of PCR for detection of *Campylobacter* in a national broiler surveillance programme in Denmark. J. Appl. Microbiol. 94, 929–935.

- Maurer, J.J., 2006. The mythology of PCR: a warning to the wise. In: Maurer, J. (Ed.), PCR Methods in Foods. Springer, US, pp. 27–40.
- Møller Nielsen, E., Engberg, J., Madsen, M., 1997. Distribution of serotypes of *Campylobacter jejuni* and *C. coli* from Danish patients, poultry, cattle and swine. FEMS Immunol. Med. Microbiol. 19, 47–56.
- Pearce, R.A., Wallace, F.M., Call, J.E., Dudley, R.L., Oser, A., Yoder, L., Sheridan, J.J., Luchansky, J.B., 2003. Prevalence of *Campylobacter* within a swine slaughter and processing facility. J. Food Prot. 66, 1550–1556.
- Ridley, A.M., Allen, V.M., Sharma, M., Harris, J.A., Newell, D.G., 2008. real-time PCR approach for detection of environmental sources of *Campylobacter* strains colonizing broiler flocks. Appl. Environ. Microbiol. 74, 2492–2504.
- Rijpens, N., Jannes, G., Herman, L., 2002. Messenger RNA-based RT-PCR detection of viable *Salmonella*. Int. Dairy J. 12, 233–238.
- Rodgers, J.D., Clifton-Hadley, F.A., Marin, C., Vidal, A.B., 2010. An evaluation of survival and detection of *Campylobacter jejuni* and *C. coli* in broiler caecal contents using culture-based methods. J. Appl. Microbiol. 109, 1244–1252.
- Rönner, A.-C., Lindmark, H., 2007. Quantitative detection of *Campylobacter jejuni* on fresh chicken carcasses by real-time PCR. J. Food Prot. 70, 1373–1378.
- Rudi, K., Hoidal, H.K., Katla, T., Johansen, B.K., Nordal, J., Jakobsen, K.S., 2004. Direct real-time PCR quantification of *Campylobacter jejuni* in chicken fecal and cecal samples by integrated cell concentration and DNA purification. Appl. Environ. Microbiol. 70, 790–797.
- Rudi, K., Moen, B., Dromtorp, S.M., Holck, A.L., 2005. Use of ethidium monoazide and PCR in combination for quantification of viable and dead cells in complex samples. Appl. Environ. Microbiol. 71, 1018–1024.
- Sheridan, G.E.C., Masters, C.I., Shallcross, J.A., Mackey, B.M., 1998. Detection of mRNA by reverse transcription-PCR as an indicator of viability in *Escherichia coli* cells. Appl. Environ. Microbiol. 64, 1313–1318.
- Skov, M.N., Carstensen, B., Tornøe, N., Madsen, M., 1999. Evaluation of sampling methods for the detection of *Salmonella* in broiler flocks. J. Appl. Microbiol. 86, 695–700.
- Taylor, D.E., Eaton, M., Yan, W., Chang, N., 1992. Genome maps of *Campylobacter jejuni* and *Campylobacter coli*. J. Bacteriol. 174, 2332–2337.
- Techathuvanan, C., Draughon, F.A., D'Souza, D.H., 2010. Real-time reverse transcriptase PCR for the rapid and sensitive detection of *Salmonella typhimurium* from pork. J. Food Prot. 73, 507–514.
- Valasek, M.A., Repa, J.J., 2005. The power of real-time PCR. Adv. Physiol. Edu. 29, 151–159.
- Wolffs, P., Norling, B., Rådström, P., 2005. Risk assessment of false-positive quantitative real-time PCR results in food, due to detection of DNA originating from dead cells. J. Microbiol. Methods 60, 315–323.
- Ziprin, R.L., Young, C.R., Byrd, J.A., Stanker, L.H., Hume, M.E., Gray, S.A., Kim, B.J., Konkel, M.E., 2001. Role of *Campylobacter jejuni* potential virulence genes in cecal colonization. Avian Dis. 45, 549–557.

Chapter 3: Fate and survival of *C. coli* in swine manure at various temperatures

This chapter focuses on the application of RT-qPCR method to detect and quantify viable *C. coli*, investigating its survival at various temperatures. The results of this work have been published at Frontiers in Microbiology Journal.

Bui XT, Wolff A, Madsen M and Bang DD (2011) Fate and survival of *Campylobacter coli* in swine manure at various temperatures. **Front. Microbiol.** Vol. 2:262. 1-9. doi: 10.3389/fmicb.2011.00262



Fate and survival of *Campylobacter coli* in swine manure at various temperatures

Xuan Thanh Bui¹, Anders Wolff², Mogen Madsen³ and Dang Duong Bang^{1*}

¹ Laboratory of Applied Micro and Nanotechnology, National Veterinary Institute, Technical University of Denmark, Aarhus N, Denmark

² BioLabChip Group, Department of Micro and Nanotechnology, Technical University of Denmark, Kongens Lyngby, Denmark

³ Dianova, Technical University of Denmark, Aarhus N, Denmark

Edited by:

Daniilo Ercolini, Università degli Studi di Napoli Federico II, Italy

Reviewed by:

Kalliopi Rantsiou, University of Turin, Italy

Christine Elizabeth Ruth Dodd, University of Nottingham, UK
Catherine Maylin Loc-Carrillo, University of Utah, USA

*Correspondence:

Dang Duong Bang, Laboratory of Applied Micro-Nanotechnology, National Veterinary Institute, Technical University of Denmark, Hangevej 2, DK-8200 Aarhus N, Denmark.
e-mail: ddba@vet.dtu.dk

Campylobacter coli is the most common *Campylobacter* species found in pig (95%), but the ability of this bacterium to survive in swine manure as well as the potential for causing human illness are poorly understood. We present here laboratory-scale experiments to investigate the effect of temperature on the survival of *C. coli* in spiked swine manure samples at temperatures from 4 to 52°C. The survival of *C. coli* during storage for 30 days was studied by three different methods: bacterial culture (plate counting), DNA qPCR, and mRNA RT-qPCR. The results indicate that *C. coli* could survive in swine manure up to 24 days at 4°C. At higher temperatures, this bacterium survived only 7 days (15°C) or 6 days (22°C) of storage. The survival of *C. coli* was extremely short (few hours) in samples incubated at 42 and 52°C. The results from the RT-qPCR method were consistent with the data from the bacterial culture method, indicating that it detected only viable *C. coli* cells, thus eliminating false-positive resulting from DNA from dead *C. coli* cells.

Keywords: RT-qPCR, *Campylobacter coli*, mRNA, *ceuE*, swine manure

INTRODUCTION

Livestock wastes such as manure or slurry from intensive animal production may contain pathogenic microorganisms including viruses, bacteria (*Escherichia coli*, *Campylobacter* spp., and *Salmonella*), and protozoa (Mawdsley et al., 1995; Semenov et al., 2009; Klein et al., 2011). There has been an increasing concern about which effect of pathogens in animal manure may have on human and animal health (Bicudo and Goyal, 2003). The manure is a potential source of contamination to the aquatic environment particularly where the slurry is used for fertilizing soil (Mawdsley et al., 1995; Marti et al., 2009; Klein et al., 2011). In addition, it has been reported that many farmers spread manure on the land straight after removal from the tanks, either because of inadequate storage capacity or greater convenience (Nicholson et al., 2005) which may release *Campylobacters* as well as other intestinal pathogens into the environment via the feces from infected animals.

Campylobacter spp. is currently the most common cause of human gastrointestinal disease worldwide. It is estimated approximately nine million human campylobacteriosis cases are reported annually in 27 countries in the EU (EU27; Andreoletti et al., 2011). The major sources of *Campylobacter* spp. are in animal intestinal tracts including chickens, cattle, pigs, wild-living mammals, and birds (Nielsen et al., 1997; Inglis et al., 2010; Oporto and Hurtado, 2011). Although 95% of the human campylobacteriosis cases attributed to *Campylobacter jejuni*, the importance of human campylobacteriosis caused by *Campylobacter coli* is being recognized due to an increased resistance of this pathogen to a greater number of antimicrobials (Gebreyes et al., 2005). Pigs are known to be frequently infected with *Campylobacter* (prevalence between

50 and 100%), to exhibit high counts of this pathogen in their feces, and to show a dominance of *C. coli* species (Boes et al., 2005; Jensen et al., 2006; Oporto et al., 2007).

It has been reported that soil is a source of microbial contamination for fruits and vegetables, as evidenced by the isolation of soil-residing pathogenic bacteria including *Campylobacters* from fresh produce. Pathogens may be transferred to the environment by application of inadequately composted or raw animal manures or sewage (Berger et al., 2010; Gardner et al., 2011; Verhoeff-Bakkenes et al., 2011). When pig feces or manures are applied to the agricultural field, the presence of *C. coli* could contaminate groundwater and soil either directly or indirectly after rainfalls. Although *C. coli* is responsible for less than 5–7% of human campylobacteriosis reported cases, the impact of this bacterium is still substantial. It is estimated that human campylobacteriosis caused by *C. coli* infection has an annual cost of millions of dollars but despite the economic importance of this pathogen, most *Campylobacter* research focuses upon *C. jejuni* (Humphrey et al., 2007; Sheppard et al., 2010). Furthermore, it has been reported recently that drinking water is the source of *C. coli* infection in grandparent breeder farms (Pérez-Boto et al., 2010). Therefore, control of the survival of this pathogen in the slurry during storage (prior to field application) is important to prevent infection in man and in animal as well as to prevent environmental contamination.

This study aimed to investigate the effect of various temperatures on the survival of *C. coli* in swine slurry using three different techniques: bacterial culture, DNA-based quantitative PCR (qPCR) and reverse transcription quantitative real-time PCR (RT-qPCR). Conventional bacterial culture methods for detection of *Campylobacter* spp. involving enrichment, isolation, and

identification at the species level are labor-intensive and time-consuming, requiring 5–6 days to complete (Collette et al., 2008). While the major limitation of the DNA-based qPCR method is the potential detection of both live and dead, or non-culturable cells (Wolffs et al., 2005), RT-qPCR method in which mRNA is targeted instead of DNA has greater potential for detecting viable cells (Maurer, 2006). Five different temperatures were selected: 4°C – a temperature used to mimic the average temperature in the slurry tank during the winter time in Denmark; 15 and 22°C, representing the average temperatures in spring and summer times, respectively; 42°C is optimal growth temperature for thermophilic *Campylobacters*; 52°C – the temperature was chosen because it has been reported that most anaerobic digestion processes of bio-waste are operated at temperatures more than 50°C (Chen, 1983; Han and Dague, 1997; Wagner et al., 2008). A putative virulence gene, the *ceuE* gene of *C. coli* was chosen as a biomarker for *C. coli* detection for both qPCR and RT-qPCR assays. This gene was selected because it represents a good candidate for *C. coli* detection as it is present in all isolated strains described to date (Gonzalez et al., 1997; Gebreyes et al., 2005; Nayak et al., 2005). Furthermore, several *ceuE* DNA-based methods have been developed for detection of *C. coli* directly from complex biological samples such as feces with a high sensitivity and specificity (Bang et al., 2003; Hong et al., 2003).

MATERIALS AND METHODS

BACTERIAL STRAINS AND CULTURE CONDITIONS

Campylobacter coli reference strain CCUG-10955 isolated from swine manure (Culture Collection of University of Gothenburg) was used in this study for spiking of swine manure samples. The strain was recovered on blood agar base No. 2 (CM271; Oxoid, Greve, Denmark) supplemented with 5% (v/v) sterile defibrinated calf blood and isolated on modified charcoal cefoperazone deoxycholate agar (mCCDA CM0739; Oxoid, Greve, Denmark) with selective supplement SR0155 (Oxoid, Greve, Denmark). The medium was prepared according to the manufacturer's instruction. A solid selective medium, Abeyta–Hunt–Bark (AHB) agar [National Veterinary Institute, Technical University of Denmark (DTU-Vet), Aarhus, Denmark] with 1% triphenyltetrazolium chloride (+TCC), was used for direct determination of colony-forming unit (CFU). All *Campylobacter* spp. used in this study were grown on blood agar plates at 42°C in microaerophilic conditions, whereas *Salmonella*, *Escherichia coli*, and *Listeria* strains were grown on blood agar plates at 37°C in aerobic conditions. *Clostridium* strain was grown on blood agar plates at 37°C in anaerobic conditions.

Bacterial DNA of *Campylobacters* ($n = 9$), *Salmonella* ($n = 5$), *E. coli* ($n = 2$), *Listeria* ($n = 1$), and *Clostridium* ($n = 1$; **Table 1**) was extracted using QIAamp® DNA Mini Kit (Qiagen, Copenhagen, Denmark). The DNA concentration was determined using a NanoDrop 1000 spectrophotometer Thermo Scientific (Saveen Werner ApS, Denmark). The bacterial DNA samples (2 ng/μl) were used to evaluate the specificity of the qPCR assays.

MANURE SAMPLES

Liquid manure slurries used in this study were collected from seven different pig farms for three times in 2 weeks in January,

Table 1 | The bacterial strains used in this study.

No.	Species	Strains	Real-time PCR
1	<i>C. coli</i>	CCUG 10955	+
2	<i>C. coli</i>	CCUG 11283	+
3	<i>C. coli</i>	CCUG 10951	+
4	<i>C. coli</i>	CCUG 12079	+
5	<i>C. jejuni</i>	SC11	–
6	<i>C. jejuni</i>	CCUG 11824	–
7	<i>C. lari</i>	CCUG 19512	–
8	<i>C. upsaliensis</i>	CCUG 15015	–
9	<i>C. fetus</i>	CCUG 6823	–
10	<i>Salmonella</i> Typhimurium	NCTC 12023	–
11	<i>S. Typhimurium</i> LT2	NCTC 12416	–
12	<i>S. Enteritidis</i>	NCTC 13349	–
13	<i>S. Enteritidis</i>	NCTC 12694	–
14	<i>S. Dublin</i>	NCTC 09676	–
15	<i>Escherichia coli</i>	NCTC 9001	–
16	<i>E. coli</i> CDT producing	E6468/62 D2253 (O127:H11)	–
17	<i>Clostridium perfringens</i>	NCTC8239	–
18	<i>Listeria monocytogenes</i>	NCTC 7973	–

2010 in Jutland (Denmark). A total of 51 of manure slurry were collected from two slurry tanks at each farm using a bucket after 10 min of mechanical mixing of the tank content. Subsequently, the contents of the bucket were stirred and a 200-ml sample was collected into a plastic bag. A total of 50 samples were stored in ice-boxes and immediately transported to the laboratory. On arrival, all samples were tested for the presence of *Campylobacter* spp. by both bacterial culture and qPCR methods as described below (see Detection of *C. coli* by Bacterial Culture Method and Detection and Quantification of *C. coli* by qPCR and RT-qPCR). Of 50 samples tested, 25 were *Campylobacter*-negative. All *Campylobacter*-negative liquid manure samples were pooled and aliquoted into 90 ml volumes and spiked with *C. coli* as follows. At an onset of the experiment, each manure sample (90 ml) was spiked with 10 ml of *C. coli* in physiological saline (0.09% NaCl) to reach a final concentration of 1×10^9 CFU/ml. The spiked samples (in triplicate) were stored in Erlenmeyer flasks (Carolina, USA) and incubated at various temperatures (4, 15, 22, 42, and 52°C) under aerobic conditions for up to 30 days. The samples incubated at high temperatures (42 and 52°C) were tested at 5 and 3 h, respectively after spiking and were not processed after day 1 until day 30. The samples incubated at 15 and 22°C were not processed after day 7. However, all samples incubated at all selected temperatures were tested by culture, qPCR, and RT-qPCR assays at day 30.

TOTAL BACTERIAL RNA AND DNA EXTRACTION

The total bacterial nucleic acids (RNA and DNA) were extracted from manure samples using cetyltrimethylammonium bromide (CTAB) buffer and a part of the RNeasy Mini RNA isolation kit (Qiagen, Copenhagen, Denmark) according to the manufacturer's protocol. Briefly, 1 ml of each bacterial manure suspension was transferred to a microcentrifuge tube and centrifuged at 8,000 g

for 7 min. The pellets were mixed with 0.5 ml of CTAB extraction buffer, 0.5 ml of phenol–chloroform–isoamyl alcohol (25:24:1, pH 8.0) and 250 mg of zirconia/silica beads. The sample and beads was mixed by vortex for 30 s. The lysate was centrifuged at 13,000 g for 5 min. The aqueous phase was purified by chloroform–isoamyl alcohol (24:1) extraction. The mixture was centrifuged at 13,000 g for 5 min. The volume of the aqueous phase was estimated and the nucleic acids were precipitated by adding a 0.08 volume of chilled 7.5 M ammonium acetate and a 0.54 volume of chilled iso-propanol. For the DNA extraction, instructions for step (a) were followed, and for the RNA extraction, instructions for step (b) were followed.

- a) The tube was inverted 20–30 times to mix the components and incubated on ice for 30–40 min. The precipitated DNA was collected by centrifugation at 13,000 g for 10 min at 4°C. The DNA pellet was washed once using ice-cold 70% ethanol and dried by air. The DNA pellet was suspended in 50 µl of DNase-free water. The DNA preparation was used immediately or stored at –20°C until needed.
- b) The mixture, including any precipitate that may have formed, was transferred to an RNeasy spin column placed in a 2-ml collection tube from the RNeasy Mini RNA isolation kit (Qiagen, Copenhagen, Denmark) and centrifuged for 15 s at 8,000 g. Washing steps were followed according to the manufacturer's protocol. The RNA was eluted in 50 µl of RNase-free water and treated with 0.3 U ml⁻¹ of DNase I Amplification Grade (Invitrogen, Denmark) according to the manufacturer's instruction. The DNA-free RNA products were transcribed to complementary DNA (cDNA) using the iScript™ cDNA Synthesis Kit (Bio-Rad, USA) with pre-mixed RNase inhibitor and random hexamer primers, according to the manufacturer's instruction.

DESIGN OF PRIMERS AND STANDARD CURVE FOR qPCR

The sequences from *ceuE* gene of *C. coli* (accession number: X88849.1) were obtained from NCBI GenBank and used for primer design. After multiple sequence alignment by using the ClustalW program (Chenna et al., 2003), a primer pair namely *ceuE-F/ceuE-R* with sequences flanking to the conserved regions in *C. coli ceuE* gene was designed using the Primer 3 program (<http://frodo.wi.mit.edu/primer3/>). The forward primer (*ceuE-F*), 5'-AAATTTCCGCTTTTGGACCT-3' (corresponding to nucleotide position 3328–3348 in *ceuE* gene) and the reverse primer (*ceuE-R*), 5'-CCTTGTGCGGTTCTTTATT-3' (corresponding to nucleotide position 3504–3524 in *ceuE* gene) were used to amplify a 196-bp fragment.

To enable accurate quantification of *C. coli*, a standard curve for the qPCR assays was generated. A 24-h growth of *C. coli* at 42°C in microaerophilic conditions on blood agar plates was harvested in physiological saline (0.09% NaCl). Serial 10-fold dilutions of *C. coli* were added to each *Campylobacter*-negative manure sample, and the spiked materials were immediately used for DNA isolation. This experiment was carried in duplicate. The DNA extracts of 10-fold dilutions from 1 × 10⁸ to 1 × 10² CFU/ml were used for qPCR assays to establish the standard curve and used for quantifying *C. coli* in swine manure.

DETECTION OF *C. COLI* BY BACTERIAL CULTURE METHOD

Duplicate 10-fold serial dilutions ranging from 10⁰ to 10⁻⁹ of each sample were prepared and 100 µl of each dilution was spread in duplicate onto pre-dried (at 22°C for 45 min) AHB plates and incubated for 48 h at 42°C in microaerophilic conditions. The selective AHB agar plates were applied according to the recommendations of ISO 10272-1:2006 (Anonymous, 2006). Plates were inspected to detect the presence of colonies presumed to be *Campylobacter* because of their characteristics. The detection limit of culture method was 500 CFU/ml. Five presumptive *Campylobacter* colonies from each manure sample were picked and used directly for verification by a conventional PCR method described previously (Lund et al., 2003).

DETECTION AND QUANTIFICATION OF *C. COLI* BY qPCR AND RT-qPCR

Quantitative real-time PCR and RT-qPCR were carried out in an Mx3005P thermocycler (Stratagene, Denmark) using *ceuE* primers. The PCR mixtures (25 µl) contained 5 µl DNA or 5 µl cDNA, 12.5 µl of 2× PCR master mix (Promega, Denmark), 400 nM of each primer and 50000× diluted SYBR green (Invitrogen, Denmark). The qPCR conditions consist of an initial heat-denaturing step at 94°C for 5 min; followed by 45 cycles of 94°C for 15 s, annealing at 56°C for 20 s, and extended at 72°C for 15 s; followed by an elongation step at 72°C for 3 min. In every qPCR analysis, the *C. coli* standard for absolute quantification was included. A negative control (5 µl of water) and a positive DNA control (5 µl) of *C. coli* DNA (2 ng/µl) were included.

Post amplification melting temperature (T_m) analysis from 60 to 95°C at 0.5°C increments was conducted to confirm specific *ceuE* product ($T_m = 80°C$). The Mx3005P detection software was used to determine threshold cycle (C_t) values, T_m , and the standard curve. Negative controls included RNase- and DNase-free water and nucleic acid extracts from un-spiked manure samples to determine any possible cross-reactivity or contamination (false-positive results). The product of ended point qPCR assays was also analyzed using agarose gel electrophoresis. Five microliters of PCR products were loaded on 2% of agarose gel (BioWhittaker, Inc., USA) containing 0.1 µg of ethidium bromide/ml and the electrophoresis was performed at 400 V for 45 min. The gel was visualized on an UV transillumination (Ultra-Violet Products, Ltd., Cambridge, UK).

STATISTICAL ANALYSES

The values were expressed as the average ± SD. The data were analyzed for statistical significance using one-way ANOVA (ANalysis Of VAriance, Microsoft Excel). A p -value ≤ 0.05 was considered to be statistically significant.

RESULTS

SPECIFICITY AND SENSITIVITY OF qPCR AND RT-qPCR ASSAYS

The specificity of assays was determined by qPCR assays with the DNA targets isolated from pure cultures of 18 *Campylobacter* and non-*Campylobacter* strains (Table 1). All *C. coli* strains ($n = 4$) were identified correctly. None of the five different *Campylobacter* species and none of the non-*Campylobacter* strains employed in the tests gave any positive signal (Table 1). The specificity of the PCR amplified products was determined by both melting

curves (T_m) and agarose gel electrophoresis analysis. As expected, a T_m single peak at 80°C for *C. coli* *ceuE* gene amplified products (Figure 1A) and a single band of 196-bp *ceuE* amplified product was obtained with agarose gel electrophoresis (Figure 1B). Un-spiked manure samples and water gave the expected negative results both in the qPCR assays and in the melting curve analysis (Figure 1). In all RT-qPCR assays, the RNA samples were amplified by qPCR to test for DNA contamination. We did not obtain any peaks at 80°C or any 196-bp amplified product by gel electrophoresis (data not shown) on DNaseI-treated nucleic acid extracts, verifying that DNA was totally removed. By using serial dilutions of *Campylobacter* DNA and mRNA extracted as described in Section “Materials and Methods” from a known number of *C. coli*, the sensitivity of qPCR and RT-qPCR were tested. The sensitivity of the DNA-based qPCR assay was as low as 100 CFU/ml, whereas the sensitivity of the RT-qPCR assay was 1000 CFU/ml, respectively.

STANDARD CURVE FOR ABSOLUTE QUANTIFICATION OF qPCR ASSAYS

To determine absolute quantification of qPCR, nucleic acid standard was generated from genomic DNA of *C. coli*. The C_t -values were plotted as a function of the cell concentration and the plot showed the expected linear relationship between the \log_{10} of *Campylobacter* CFU per milliliter (CFU/ml) and C_t -values

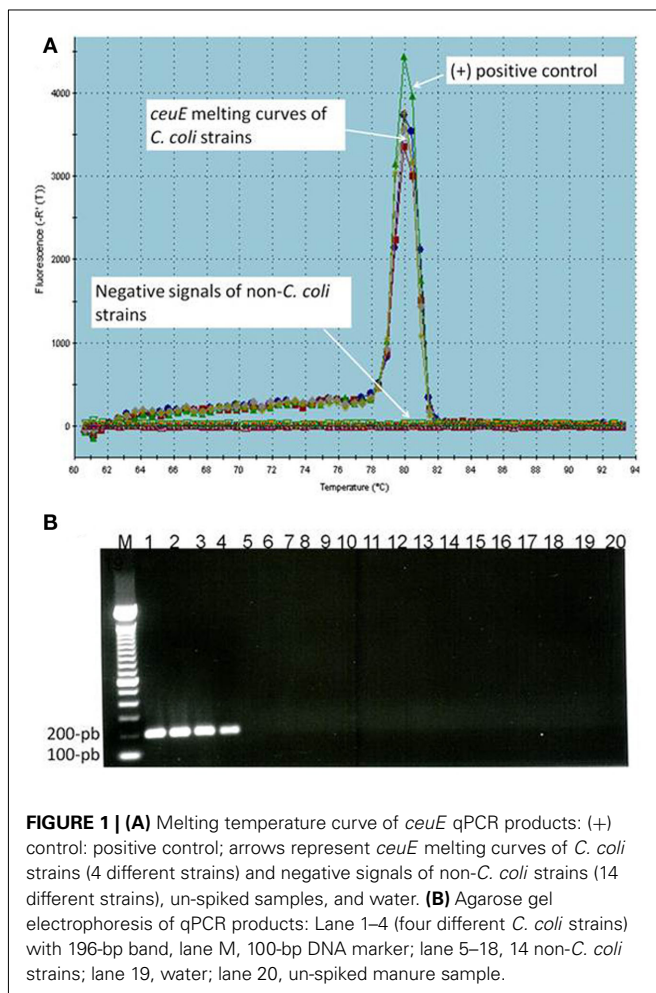

(Figure 2). The standard curve slope was -3.218 , which corresponded to $\sim 100\%$ efficiency for the PCR assay, using the formula E (efficiency) = $(10^{-1/\text{slope}}) - 1$ and the calibration curve is linear with a correlation coefficient (R^2) = 0.996.

DETERMINATION OF SURVIVAL OF *C. COLI* IN SWINE MANURE BY BACTERIAL CULTURE AND RT-qPCR METHODS

Figure 3 shows the levels of *C. coli* in manure samples incubated at five different temperatures: 4, 15, 22, 42, and 52°C. A decrease level of *C. coli* in all swine manure samples was observed throughout the experiment at all incubation temperatures by both bacterial culture and RT-qPCR methods. At 4°C, the viable *C. coli* cells were detected up to day 24 of storage by both methods (Figure 3A). Using bacterial culture and RT-qPCR methods, approximately 5×10^7 and 6.0×10^3 CFU/ml were obtained at day 1 and day 24, respectively (Figure 3A). At 15°C, the viable *C. coli* cells in manure samples were still detectable up to day 7 (approximately 1.2×10^3 CFU/ml) by bacterial culture method but could only be detected by RT-qPCR until day 6 ($\sim 1 \times 10^3$ CFU/ml; Figure 3B). At 22°C, the viable *C. coli* cells were detected up to day 6 with approximately 6.2×10^3 and 2×10^3 CFU/ml obtained by bacterial culture method and RT-qPCR method, respectively (Figure 3C). As shown in Figures 3D,E, a rapid decrease of the counts of viable *C. coli* cells was observed at 42°C (approximately 1.5×10^4 CFU/ml) and 52°C (approximately 1×10^4 CFU/ml) using the bacterial culture method after 5 and 3 h of incubation, respectively. At these high temperatures, viable *C. coli* cells were not detected by both methods after 24 h. It should note that all samples were incubated until day 30.

PERSISTENCE OF *C. COLI* DNA IN SWINE MANURE

As shown in Figures 3A–C, a slight decrease level of *C. coli* DNA was obtained using DNA-based qPCR method at 4, 15, and 22°C. At 4°C, approximately 1.2×10^8 and 2.8×10^7 CFU/ml were obtained at day 1 and day 24, respectively. At 15 and 22°C, we observed the similar amounts of *C. coli* DNA ranging from $\sim 1 \times 10^8$ to 2.7×10^7 CFU/ml at day 1 and day 7, respectively (Figures 3B,C). Although none of viable *C. coli* cells was observed by either bacterial culture or RT-qPCR method at day 30 of storage, high levels ($\sim 2 \times 10^7$ CFU/ml) of *C. coli* DNA were still observed by DNA-based qPCR method in all samples at these incubation temperatures (4, 15, and 22°C; data not shown). At higher temperatures (42 and 52°C), although a slight decrease level of *C. coli* DNA was obtained after 24 h, it was still persistent until day 30 with approximately 1.5×10^3 CFU/ml (Figures 3D,E).

DISCUSSION

The introduction of new molecular methods has become an especially important advance in reducing the time required for the detection of *Campylobacter* spp. and detecting viable bacteria in environmental samples through their DNA (Rudi et al., 2004; Ridley et al., 2008). The precise correlation of cell viability and the detected level of DNA have been shown to be poor, since bacterial DNA persists in dead cells for significant periods of time (Masters et al., 1994; Young et al., 2007). It has been demonstrated that bacterial DNA persisted in a PCR-detectable form in culture-negative environmental (Deere et al., 1996), and clinical samples (Hellyer

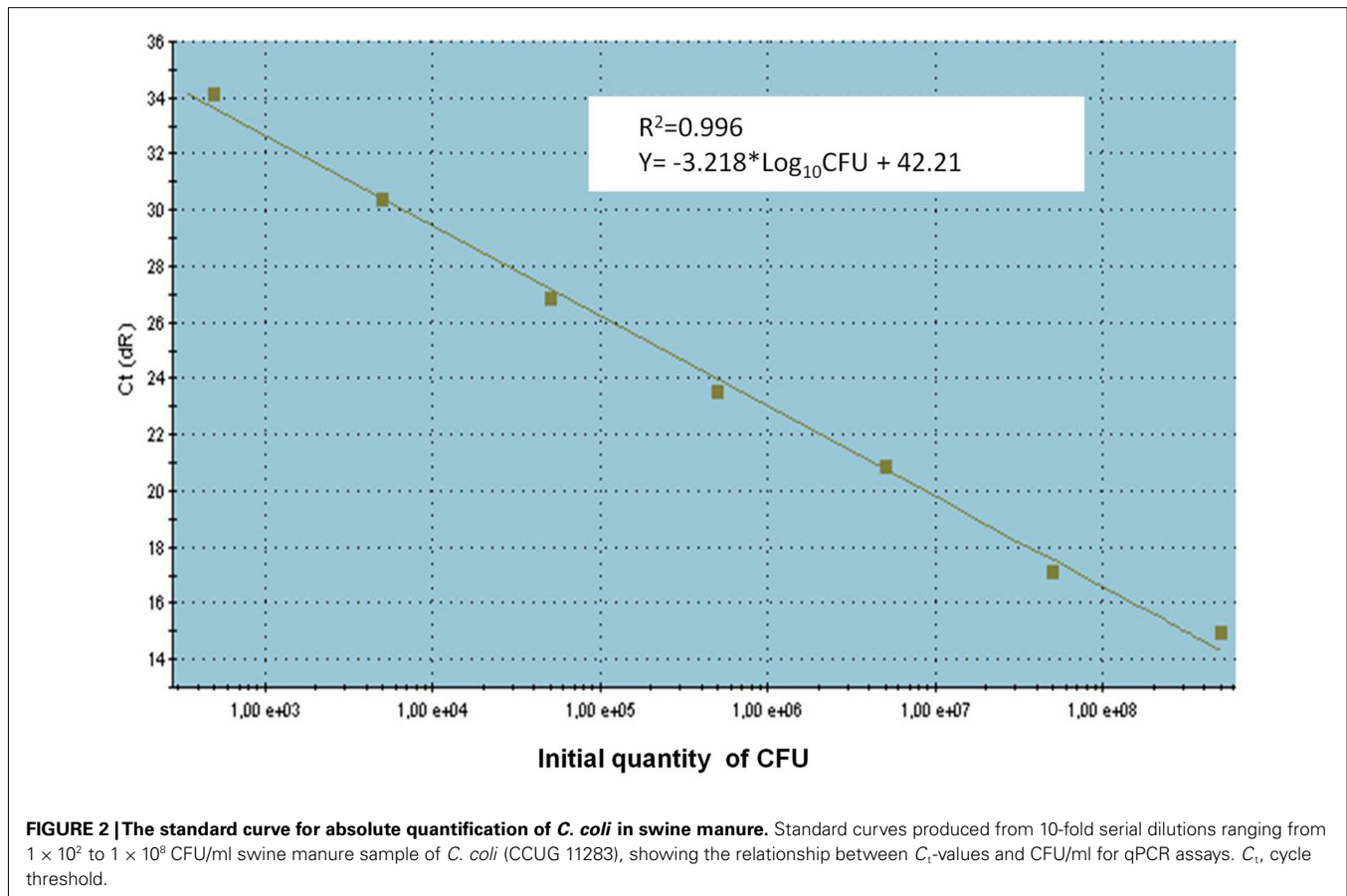

et al., 1999). In contrast, the half-life of most bacterial mRNA has been reported to range from 0.5 to 50 min (Takayama and Kjelleberg, 2000). In addition, it has been shown that the use of bacterial mRNA for RT-qPCR could provide a more closely correlated indication of the cell viability status than DNA-based methods (Keer and Birch, 2003).

In the present study, we use mRNA as a marker for cell viability, and *ceuE* gene, a putative virulence gene of *C. coli* was selected as a biomarker for viable cells using RT-qPCR method. The *ceuE* gene product – a lipoprotein, plays an important role as a component of a protein-binding-dependent transport system for the siderophore enterochelin of *C. coli* (Richardson and Park, 1995). Our data indicated that the viable cells counts of *C. coli* in swine manure at all incubation temperatures determined by RT-qPCR and by culture method were almost equivalent (Figure 3). The results are in a good agreement with a previous study reported by Matsuda et al. (2006) who used RT-qPCR to enumerate bacteria in human feces and peripheral blood. Moreover, the positive signals were observed by RT-qPCR as long as viable *C. coli* cells were counted by bacterial culture method. In contrast, our results showed that the levels of *C. coli* DNA in manure obtained by DNA-based qPCR method were significantly ($p < 0.001$) higher than those obtained by either bacterial culture or RT-qPCR method in all manure samples at all incubation temperatures tested. Although no viable *C. coli* cells were detected by either bacterial culture or RT-qPCR in any manure samples stored at day 30, the significant levels of *C. coli* DNA were still detected by DNA-based qPCR showing that

this method gave false-positive resulting from DNA from dead *C. coli* cells. Similar results have been found in several previous studies and the explanation for this phenomenon is the use of qPCR to detect the DNA as target could also detect the DNA from dead or non-viable cells (Lund et al., 2004; Rudi et al., 2004; Wolffs et al., 2005). It was reported that DNA from dead bacterial cells could persist for up to 3 weeks after the cell death (Josephson et al., 1993) and that persistence could lead to an overestimation of the number of viable cells and false-positive results (Wolffs et al., 2005). RT-qPCR is therefore superior to DNA-based qPCR for determining the concentration of viable bacteria.

Recently, it has been reported that propidium monoazide PCR (PMA-PCR) and ethidium monoazide PCR (EMA-PCR) could be used to detect and to quantify viable *Campylobacter* in complex samples (Rudi et al., 2005; Inglis et al., 2010; Josefsen et al., 2010). However, the advantage of our method presented here is that by detecting the mRNA level of a putative virulence gene, it is not only possible to detect and quantify viable *C. coli* but also to study the potential pathogenicity of this bacterium during the storage of manure.

Temperature has been shown to be a major factor determining pathogen inactivation during the storing and composting of animal manures (Hutchison et al., 2005; Nicholson et al., 2005; Larney and Hao, 2007). However, little is known about quantitative data on microbial inactivation rates and the influence of temperature in these materials, if not controversial (Inglis et al., 2010). In this study, the influence of temperature on the survival

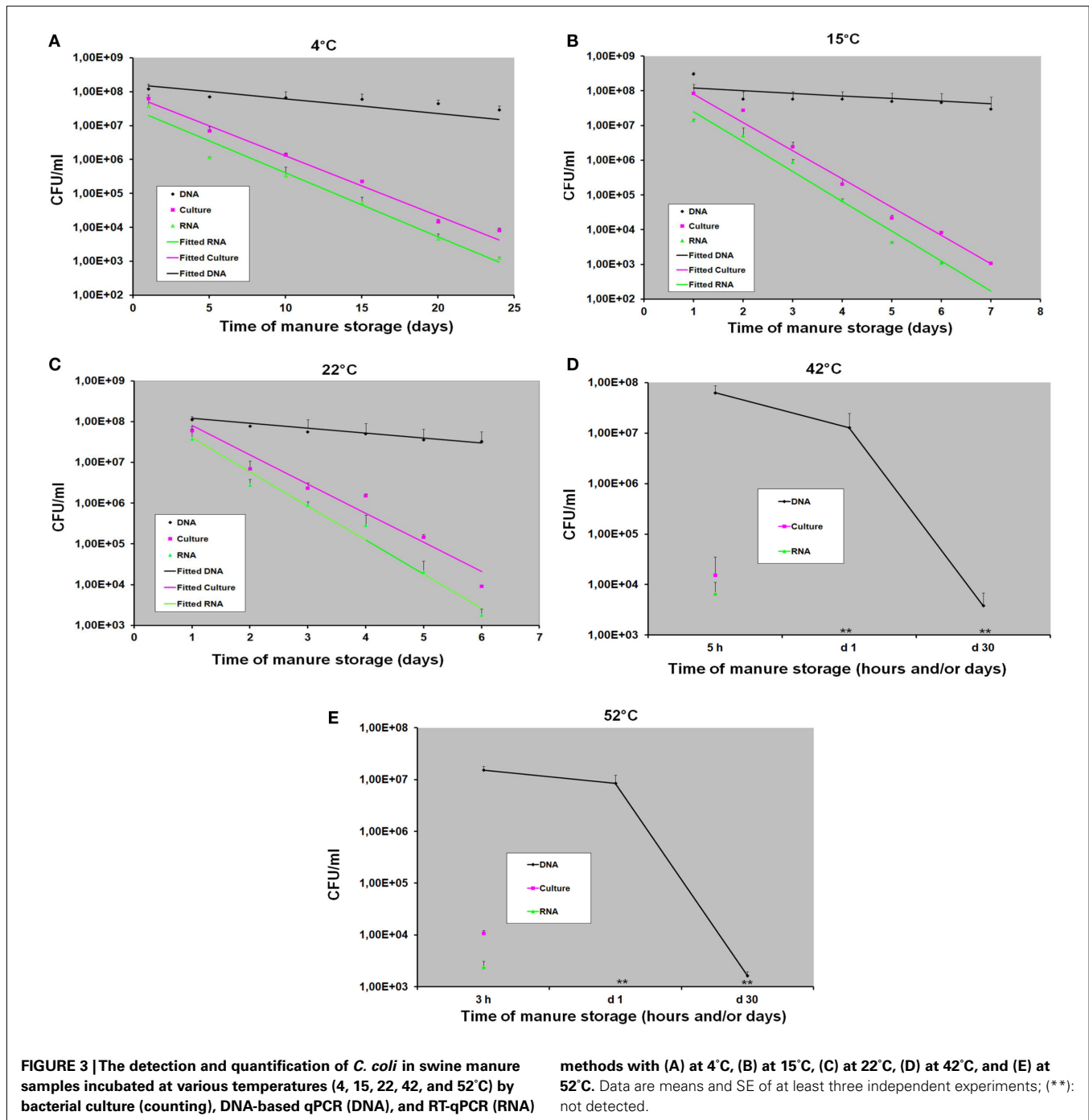

and fate of *C. coli* in swine manure stored at various temperatures was investigated. Using bacterial culture and RT-qPCR methods, a great decline of viable *C. coli* cells was observed at high temperatures (15, 22, 42, and 52°C). Our findings are in very good agreement with data from (Hänel and Atanassova, 2007) who showed that the number of *Campylobacter* on turkey meat samples incubated at 25°C was severely decreased in comparison to the same samples incubated at 4°C. Our data also showed that *C. coli* could survive up to 24 days in the samples incubated at 4°C in aerobic conditions. In contrast, at higher temperatures (at

42 or 52°C), no viable *C. coli* cells were detected after 24 h using either bacterial culture or RT-qPCR method. These findings are in agreement with data from previous study reported by Garénaux et al. (2009) who revealed that a cross protection between the cold shock response and oxidative stress response might explain the increased resistance of bacteria at low temperature. In addition, it has been shown that superoxide dismutase, as well as other oxidized stress related proteins were over-expressed at 4°C (Stintzi, 2003). Several studies have suggested that the enhanced survival of *Campylobacter* in various biological milieus is due to cold stress

(Buswell et al., 1998; Chan et al., 2001; Moen et al., 2005). Furthermore, a number of genes involved in energy metabolism have been reported to be up-regulated at 5°C in comparison to at 25°C (Moen et al., 2005). Few data are available on survival of *Campylobacter* spp. under oxidative stress conditions in animal manures, especially swine manure. In this study, the swine manure samples were collected from open slurry tanks at the pig farm and the conditions for testing resembled aerobic conditions at the farm. From the data of our study, it seems that the survival of *C. coli* in swine manure under aerobic conditions depends on temperature. This is of particular importance because at low temperature (4°C) used allows bacterial survival longer and at higher rates (24 days), while at higher temperatures (42 and 52°C), survival of *C. coli* is severely affected (few hours).

Outbreaks of food-borne illness caused by food-borne pathogens associated with contaminated fruit and vegetables have recently reported and received worldwide attention (Pakalniskiene et al., 2009; Gajraj et al., 2011; Gardner et al., 2011). Vegetables can become contaminated with pathogenic organisms while growing or during harvesting and the most likely source is the application of manure or compost as fertilizer to fields where crops are grown and the fecal contamination of irrigation water (Berger et al., 2010; Oliveira et al., 2010). In addition, the storage of manure plays an important role in survival of pathogens during transmission (Kearney et al., 1993). The results of our study suggest that swine manure before

application on the agricultural soil should be treated properly such as increasing the temperature up to 42°C or even more than 52°C for few hours since low temperatures allow *Campylobacters* survive a longer time (at least 24 days at 4°C).

In summary, this study compared, for the first time, the survival of *C. coli* in swine manure at various temperatures is investigated using bacterial culture method and molecular methods. The data suggest that *C. coli* in swine manure might be sensitive to aerobic conditions at high temperatures (15 and 22°C), especially at 42 and 52°C. Exposure to high temperatures has a stronger effect on survival of *C. coli* in swine manure than at low temperature (4°C). Furthermore, a good correlation was observed throughout the experiments between the number of viable *C. coli* cells obtained by RT-qPCR and those obtained by bacterial culture method. In contrast, greater differences between DNA *C. coli* levels obtained by DNA-based qPCR and CFU levels obtained by either bacterial culture or RT-qPCR method. Our findings draw an attention for the need of determining the level of contaminated pathogens at various temperatures in whole-slurry or manure before applying to the agricultural soil.

ACKNOWLEDGMENTS

This study was supported by the Pathos Project funded by the Strategic Research Council of Denmark (ENV 2104-07-0015). We thank Jonas Høgberg for skilled technical assistance.

REFERENCES

- Andreoletti, O., Budka, H., Buncic, S., Collins, J. D., Griffin, J., Hald, T., Havelaar, A., Hope, J., Klein, G., Mclauchlin, J., Müller-Graf, C., Nguyen-The, C., Noerrung, B., Peixe, L., Maradona, M. P., Ricci, A., Sofos, J., Threlfall, J., Vågsholm, I., and Vanopdenbosch, E. (2011). Scientific opinion on *Campylobacter* in broiler meat production: control options and performance objectives and/or targets at different stages of the food chain. *EFSA J.* 9, 141.
- Anonymous. (2006). *Microbiology of Food and Animal Feeding Stuff—Horizontal Method for Detection and Enumeration of Campylobacter spp.* BS EN ISO 10272-1:2006. London: British Standards Institution.
- Bang, D. D., Nielsen, E. M., Scheutz, F., Pedersen, K., Handberg, K., and Madsen, M. (2003). PCR detection of seven virulence and toxin genes of *Campylobacter jejuni* and *Campylobacter coli* isolates from Danish pigs and cattle and cytolethal distending toxin production of the isolates. *J. Appl. Microbiol.* 94, 1003–1014.
- Berger, C. N., Sodha, S. V., Shaw, R. K., Griffin, P. M., Pink, D., Hand, P., and Frankel, G. (2010). Fresh fruit and vegetables as vehicles for the transmission of human pathogens. *Environ. Microbiol.* 12, 2385–2397.
- Bicudo, J. R., and Goyal, S. M. (2003). Pathogens and manure management systems: a review. *Environ. Technol.* 24, 115–130.
- Boes, J., Nersting, L., Nielsen, E. M., Kranker, S., En, Oslash, E. C., Wachmann, H. C., and Baggesen, D. L. (2005). Prevalence and diversity of *Campylobacter jejuni* in pig herds on farms with and without cattle or poultry. *J. Food Prot.* 68, 722–727.
- Buswell, C. M., Herlihy, Y. M., Lawrence, L. M., Mcguiggan, J. T. M., Marsh, P. D., Keevil, C. W., and Leach, S. A. (1998). Extended survival and persistence of *Campylobacter* spp. in water and aquatic biofilms and their detection by immunofluorescent-antibody and -rRNA staining. *Appl. Environ. Microbiol.* 64, 733–741.
- Chan, K. F., Le Tran, H., Kanenaka, R. Y., and Kathariou, S. (2001). Survival of clinical and poultry-derived isolates of *Campylobacter jejuni* at a low temperature (4°C). *Appl. Environ. Microbiol.* 67, 4186–4191.
- Chen, Y. R. (1983). Kinetic analysis of anaerobic digestion of pig manure and its design implications. *Agric. Wastes* 8, 65–81.
- Chenna, R., Sugawara, H., Koike, T., Lopez, R., Gibson, T. J., Higgins, D. G., and Thompson, J. D. (2003). Multiple sequence alignment with the clustal series of programs. *Nucleic Acids Res.* 31, 3497–3500.
- Collette, F., Whichard, J., and Nachamkin, I. (2008). “Diagnosis and antimicrobial susceptibility of *Campylobacter* species,” in *Campylobacter*, 3rd Edn, eds I. Nachamkin, C. M. Szymanski, and M. J. Blaser (Washington, DC: ASM Press), 227–243.
- Deere, D., Porter, J., Pickup, R. W., and Edwards, C. (1996). Survival of cells and DNA of *Aeromonas salmonicida* released into aquatic microcosms. *J. Appl. Microbiol.* 81, 309–318.
- Gajraj, R., Pooransingh, S., Hawker, J. I., and Olowokure, B. (2011). Multiple outbreaks of *Salmonella* braenderup associated with consumption of iceberg lettuce. *Int. J. Environ. Health Res.* 1–6.
- Gardner, T. J., Fitzgerald, C., Xavier, C., Klein, R., Pruckler, J., Stroika, S., and Mclaughlin, J. B. (2011). Outbreak of campylobacteriosis associated with consumption of raw peas. *Clin. Infect. Dis.* 53, 26–32.
- Garénaux, A., Ritz, M., Jugiau, F., Rama, F., Federighi, M., and De Jonge, R. (2009). Role of oxidative stress in *C. jejuni* inactivation during freeze-thaw treatment. *Curr. Microbiol.* 58, 134–138.
- Gebreyes, W. A., Thakur, S., and Morrow, W. E. M. (2005). *Campylobacter coli*: prevalence and antimicrobial resistance in antimicrobial-free (ABF) swine production systems. *J. Antimicrob. Chemother.* 56, 765–768.
- Gonzalez, I., Grant, K., Richardson, P., Park, S., and Collins, M. (1997). Specific identification of the enteropathogens *Campylobacter jejuni* and *Campylobacter coli* by using a PCR test based on the *ceuE* gene encoding a putative virulence determinant. *J. Clin. Microbiol.* 35, 759–763.
- Han, Y., and Dague, R. R. (1997). Laboratory studies on the temperature-phased anaerobic digestion of domestic primary sludge. *Water Environ. Res.* 69, 1139–1143.
- Hänel, C. M., and Atanassova, V. (2007). Impact of different storage factors on the survivability of *Campylobacter jejuni* in turkey meat. *FEMS Immunol. Med. Microbiol.* 49, 146–148.
- Hellyer, T. J., Desjardin, L. E., Hehman, G. L., Cave, M. D., and Eisenach, K. D. (1999). Quantitative analysis of mRNA as a marker for viability of *Mycobacterium tuberculosis*. *J. Clin. Microbiol.* 37, 290–295.
- Hong, Y., Berrang, M. E., Liu, T., Hofacre, C. L., Sanchez, S., Wang, L., and Maurer, J. J. (2003). Rapid detection of *Campylobacter coli*, *C. jejuni*, and *Salmonella enterica* on poultry carcasses by using PCR-enzyme-linked immunosorbent assay. *Appl. Environ. Microbiol.* 69, 3492–3499.

- Humphrey, T., O'Brien, S., and Madsen, M. (2007). *Campylobacters* as zoonotic pathogens: a food production perspective. *Int. J. Food Microbiol.* 117, 237–257.
- Hutchison, M. L., Walters, L. D., Moore, A., and Avery, S. M. (2005). Declines of zoonotic agents in liquid livestock wastes stored in batches on-farm. *J. Appl. Microbiol.* 99, 58–65.
- Inglis, G. D., Mcallister, T. A., Larney, F. J., and Topp, E. (2010). Prolonged survival of *Campylobacter* species in bovine manure compost. *Appl. Environ. Microbiol.* 76, 1110–1119.
- Jensen, A. N., Dalsgaard, A., Baggesen, D. L., and Nielsen, E. M. (2006). The occurrence and characterization of *Campylobacter jejuni* and *C. coli* in organic pigs and their outdoor environment. *Vet. Microbiol.* 116, 96–105.
- Josefson, M. H., Lofstrom, C., Hansen, T. B., Christensen, L. S., Olsen, J. E., and Hoorfar, J. (2010). Rapid quantification of viable *Campylobacter* bacteria on chicken carcasses, using real-time PCR and propidium monoazide treatment, as a tool for quantitative risk assessment. *Appl. Environ. Microbiol.* 76, 5097–5104.
- Josephson, K. L., Gerba, C. P., and Pepper, I. L. (1993). Polymerase chain reaction detection of nonviable bacterial pathogens. *Appl. Environ. Microbiol.* 59, 3513–3515.
- Kearney, T. E., Larkin, M. J., and Levett, P. N. (1993). The effect of slurry storage and anaerobic digestion on survival of pathogenic bacteria. *J. Appl. Microbiol.* 74, 86–93.
- Keer, J. T., and Birch, L. (2003). Molecular methods for the assessment of bacterial viability. *J. Microbiol. Methods* 53, 175–183.
- Klein, M., Brown, L., Ashbolt, N. J., Stuetz, R. M., and Roser, D. J. (2011). Inactivation of indicators and pathogens in cattle feedlot manures and compost as determined by molecular and culture assays. *FEMS Microbiol. Ecol.* 77, 200–210.
- Larney, F. J., and Hao, X. (2007). A review of composting as a management alternative for beef cattle feedlot manure in southern Alberta, Canada. *Bioresour. Technol.* 98, 3221–3227.
- Lund, M., Nordentoft, S., Pedersen, K., and Madsen, M. (2004). Detection of *Campylobacter* spp. in chicken fecal samples by real-time PCR. *J. Clin. Microbiol.* 42, 5125–5132.
- Lund, M., Wedderkopp, A., Wainø, M., Nordentoft, S., Bang, D. D., Pedersen, K., and Madsen, M. (2003). Evaluation of PCR for detection of *Campylobacter* in a national broiler surveillance programme in Denmark. *J. Appl. Microbiol.* 94, 929–935.
- Marti, R., Dabert, P., and Pourcher, A.-M. (2009). Pig manure contamination marker selection based on the influence of biological treatment on the dominant fecal microbial groups. *Appl. Environ. Microbiol.* 75, 4967–4974.
- Masters, C. I., Shallcross, J. A., and Mackey, B. M. (1994). Effect of stress treatments on the detection of *Listeria monocytogenes* and enterotoxigenic *Escherichia coli* by the polymerase chain reaction. *J. Appl. Microbiol.* 77, 73–79.
- Matsuda, K., Tsuji, H., Asahara, T., Kado, Y., and Nomoto, K. (2006). Sensitive quantitative detection of commensal bacteria by rRNA-targeted reverse transcription (RT)-PCR. *Appl. Environ. Microbiol.* 73, 32–39.
- Maurer, J. J. (2006). “The mythology of PCR: a warning to the wise,” in *PCR Methods in Foods*, ed. J. Maurer (New York, NY: Springer), 27–40.
- Mawdsley, J. L., Bardgett, R. D., Merry, R. J., Pain, B. F., and Theodorou, M. K. (1995). Pathogens in livestock waste, their potential for movement through soil and environmental pollution. *Appl. Soil Ecol.* 1, 1–15.
- Moen, B., Oust, A., Langsrud, O., Dorell, N., Marsden, G. L., Hinds, J., Kohler, A., Wren, B. W., and Rudi, K. (2005). Explorative multifactor approach for investigating global survival mechanisms of *Campylobacter jejuni* under environmental conditions. *Appl. Environ. Microbiol.* 71, 2086–2094.
- Nayak, R., Stewart, T. M., and Nawaz, M. S. (2005). PCR identification of *Campylobacter coli* and *Campylobacter jejuni* by partial sequencing of virulence genes. *Mol. Cell. Probes* 19, 187–193.
- Nicholson, F. A., Groves, S. J., and Chambers, B. J. (2005). Pathogen survival during livestock manure storage and following land application. *Bioresour. Technol.* 96, 135–143.
- Nielsen, E. M., Engberg, J., and Madsen, M. (1997). Distribution of serotypes of *Campylobacter jejuni* and *C. coli* from Danish patients, poultry, cattle and swine. *FEMS Immunol. Med. Microbiol.* 19, 47–56.
- Oliveira, M., Usall, J., Viñas, I., Anguera, M., Gatiús, F., and Abadias, M. (2010). Microbiological quality of fresh lettuce from organic and conventional production. *Food Microbiol.* 27, 679–684.
- Oporto, B., Esteban, J. I., Aduriz, G., Juste, R. A., and Hurtado, A. (2007). Prevalence and strain diversity of thermophilic *Campylobacters* in cattle, sheep and swine farms. *J. Appl. Microbiol.* 103, 977–984.
- Oporto, B., and Hurtado, A. (2011). Emerging thermotolerant *Campylobacter* species in healthy ruminants and swine. *Foodborne Pathog. Dis.* 8, 807–813.
- Pakalniskiene, J., Falkenhorst, G., Lisby, M., Madsen, S. B., Olsen, K. E. P., Nielsen, E. M., Mygh, A., Boel, J., and Mølbak, K. (2009). A foodborne outbreak of enterotoxigenic *E. coli* and *Salmonella* Anatum infection after a high-school dinner in Denmark, November 2006. *Epidemiol. Infect.* 137, 396–401.
- Pérez-Boto, D., García-Peña, F. J., Abad-Moreno, J. C., Hurtado-Pizarro, M. D., Pérez-Cobo, I., and Aurora Echeita, M. (2010). Drinking water as the source of *Campylobacter coli* infection in grandparent heavy breeders. *Avian Pathol.* 39, 483–487.
- Richardson, P. T., and Park, S. F. (1995). Enterochelin acquisition in *Campylobacter coli*: characterization of components of a binding-protein-dependent transport system. *Microbiology* 141, 3181–3191.
- Ridley, A. M., Allen, V. M., Sharma, M., Harris, J. A., and Newell, D. G. (2008). Real-time PCR approach for detection of environmental sources of *Campylobacter* strains colonizing broiler flocks. *Appl. Environ. Microbiol.* 74, 2492–2504.
- Rudi, K., Hoidal, H. K., Katla, T., Johansen, B. K., Nordal, J., and Jakobsen, K. S. (2004). Direct real-time PCR quantification of *Campylobacter jejuni* in chicken fecal and cecal samples by integrated cell concentration and DNA purification. *Appl. Environ. Microbiol.* 70, 790–797.
- Rudi, K., Moen, B., Dromtorp, S. M., and Holck, A. L. (2005). Use of ethidium monoazide and PCR in combination for quantification of viable and dead cells in complex samples. *Appl. Environ. Microbiol.* 71, 1018–1024.
- Semenov, A. V., Van Overbeek, L., and Van Bruggen, A. H. C. (2009). Percolation and survival of *Escherichia coli* O157:H7 and *Salmonella* enterica serovar Typhimurium in soil amended with contaminated dairy manure or slurry. *Appl. Environ. Microbiol.* 75, 3206–3215.
- Sheppard, S. K., Dallas, J. F., Wilson, D. J., Strachan, N. J. C., Mccarthy, N. D., Jolley, K. A., Colles, F. M., Rotariu, O., Ogden, I. D., Forbes, K. J., and Maiden, M. C. J. (2010). Evolution of an agriculture-associated disease causing *Campylobacter coli* clade: evidence from national surveillance data in Scotland. *PLoS ONE* 5, e15708. doi:10.1371/journal.pone.0015708
- Stintzi, A. (2003). Gene expression profile of *Campylobacter jejuni* in response to growth temperature variation. *J. Bacteriol.* 185, 2009–2016.
- Takayama, K., and Kjelleberg, S. (2000). The role of RNA stability during bacterial stress responses and starvation. *Environ. Microbiol.* 2, 355–365.
- Verhoeff-Bakkenes, L., Jansen, H. A. P. M., In 't Veld, P. H., Beumer, R. R., Zwietering, M. H., and Van Leusden, F. M. (2011). Consumption of raw vegetables and fruits: a risk factor for *Campylobacter* infections. *Int. J. Food Microbiol.* 144, 406–412.
- Wagner, A. O., Gstraunthaler, G., and Illmer, P. (2008). Survival of bacterial pathogens during the thermophilic anaerobic digestion of biowaste: laboratory experiments and in situ validation. *Anaerobe* 14, 181–183.
- Wolffs, P., Norling, B., and Rådström, P. (2005). Risk assessment of false-positive quantitative real-time PCR results in food, due to detection of DNA originating from dead cells. *J. Microbiol. Methods* 60, 315–323.
- Young, G., Turner, S., Davies, J. K., Sundqvist, G., and Figdor, D. (2007). Bacterial DNA persists for extended periods after cell death. *J. Endod.* 33, 1417–1420.

Conflict of Interest Statement: The authors declare that the research was conducted in the absence of any commercial or financial relationships that could be construed as a potential conflict of interest.

Received: 21 October 2011; accepted: 07 December 2011; published online: 26 December 2011.

Citation: Bui XT, Wolff A, Madsen M and Bang DD (2011) Fate and survival of *Campylobacter coli* in swine manure at various temperatures. *Front. Microbiol.* 2:262. doi: 10.3389/fmicb.2011.00262

This article was submitted to *Frontiers in Food Microbiology*, a specialty of *Frontiers in Microbiology*.

Copyright © 2011 Bui, Wolff, Madsen and Bang. This is an open-access article distributed under the terms of the Creative Commons Attribution Non-Commercial License, which permits non-commercial use, distribution, and reproduction in other forums, provided the original authors and source are credited.

Chapter 4: Survival and transport of manure-borne pathogens in soil and water using soil columns

This chapter focuses on the survival and transport of manure-borne pathogens other than *Campylobacter* spp. in soil and water using soil columns. This study was conducted by collaborating with other partners of Pathos project.

M.G. Mostofa Amin, Forslund A, **Bui XT**, Juhler RK, Petersen SO and Lægdsmand M (2011) **Persistence and Leaching Potential of Microorganisms and Mineral N of Animal Manure Applied to Intact Soil Columns. Draft (ready to submit)**

Persistence and Leaching Potential of Microorganisms and Mineral N of Animal Manure Applied to Intact Soil Columns

Running Title: Leaching of Manure-Borne Microorganisms

Author List

M.G. Mostofa Amin^{1,*}, Anita Forslund², Xuan Thanh Bui³, René K. Juhler⁴, Søren O. Petersen¹ and Mette Lægdsmand¹

Authors' Affiliation

¹ Department of Agroecology, Aarhus University, Blichers Alle 20, 8830 Tjele; ²Department of Veterinary Disease Biology, Faculty of Life Sciences, University of Copenhagen, Groennegaardsvej 15, DK-1870 Frederiksberg C, Denmark; ³National Veterinary Institute, Technical University of Denmark, Hangøvej 2, DK-8200 Aarhus N, Denmark; and ⁴Department of Geochemistry, Geological Survey of Denmark and Greenland, Øster Voldgade 10, DK-1350 Copenhagen K, Denmark.

***Corresponding Address**

Department of Agroecology
Faculty of Science and Technology, Aarhus University
Blichers Alle 20, Post box 50, 8830 Tjele, Denmark

*Email: Mostofa.Amin@agrsci.dk

Telephone: +4589991833

Fax: +4589991200

ABSTRACT

Pathogens may reach agricultural soils through application of animal manure and hereby pose a risk of contaminating crops as well as surface- and groundwater. Liquid manure (slurry) treatment by solid-liquid separation and ozonation, and field application by sub-surface injection are practices for improved nutrient and odor management which may also influence the amount and fate of manure-borne pathogens in agricultural soil. A study was conducted to investigate the leaching potentials as percentages of total applied of a phage (*Salmonella* Typhimurium Bacteriophage 28B) and two bacteria, *Escherichia coli* and *Enterococcus* spp., in raw slurry, in the liquid fraction of separated slurry, and in the liquid fraction after ozonation, when applied to intact soil columns. We also compared leaching potentials of surface-applied and subsurface-injected raw slurry. The columns were exposed to irrigation events after 1, 2, 3, and 4 week of incubation (3.5-h period at 10 mm h⁻¹) with collection of leachate. By the end of incubation the distribution and survival of microorganisms in the soil of these treatments, and in non-irrigated columns with injected raw slurry or liquid fraction, were determined. *E. coli* in the leachates was quantified both by plate counting and by qPCR to assess the proportion of culturable and non-culturable state. Solid-liquid separation of slurry increased the redistribution of contaminants in liquid fraction in the soil compared to raw slurry, and the recovery of *E. coli* and *Enterococcus* spp. was higher for liquid fraction after the four leaching events. Liquid fraction also resulted in higher leaching of all contaminants except *Enterococcus* spp. than raw slurry. Ozonation reduced *E. coli* leaching only. Injection enhanced the leaching potential of the microorganisms investigated compared to surface application, probably because of a better survival under injection and a shorter leaching path.

Keywords: Manure separation, groundwater contamination, bacteria, virus, microbial transport, leaching risk, qPCR.

INTRODUCTION

Animal manure is widely returned to agricultural soil as a source of nutrients and organic matter. Inappropriate use of animal manure has been recognized as a source of nitrate pollution of groundwater (Mantovi et al., 2006) and eutrophication of surface waters (Norrington and Jorgensen, 2009), but manure may also release pathogenic bacteria and viruses to the soil environment (Mawdsley et al., 1995; Guber et al., 2009; Lee et al., 2007). Unless properly regulated, contamination of drinking water, bathing facilities, and fresh produce of leafy and root crops by manure-borne pathogens can cause diseases to humans and wild life (Albihn and Vinneras, 2007; van Overbeek et al., 2010; Franz and van Bruggen, 2008).

The environmental fate of manure-borne contaminants has received attention in the past (Lee et al., 2007; Unc and Goss, 2004), but recent developments in manure management techniques for improved nutrient and odor management, including solid-liquid separation and chemical treatments (Hjorth et al., 2010; Burton, 2007), may alter the environmental fate of some contaminants (Peters et al., 2011; Glaesner et al., 2011b). It has been shown that after field application manure-borne microorganisms can survive for two to three months at 5–25°C (Cools et al., 2001), and they can move with runoff or infiltrating water as free cells and/or attached to soil and manure particles (Guber et al., 2007b; Guber et al., 2005; Cao et al., 2010). Microorganisms can be strained physically in narrow soil pore spaces or water films, or they can attach chemically to soil and immobile slurry particles (Bradford et al., 2006; Unc and Goss, 2004). On the other hand, this filtering effect of soils can be severely reduced by preferential flow and macropore flow in structured soil (Bech et al., 2010; Smiles, 1988).

In Europe more than 65% of the manure is managed in liquid form as slurry (Oenema et al., 2007). Slurry is usually applied to agricultural fields by surface-application or, increasingly, by injection at 6–10 cm soil depth to reduce nuisance odor and NH₃ volatilization from the applied slurry (Hadrich

et al., 2010; Huijsmans et al., 2003; Webb et al., 2010). These two application methods may represent different risks of leaching of nutrients and microorganisms as a result of the difference in slurry-soil contact (Cameron et al., 1996; Bech et al., 2011; Glaesner et al., 2011b).

Slurry dry matter (SDM) content is important for the redistribution of slurry liquid in the soil after field application (Petersen et al., 2003). Solid-liquid separation techniques typically remove 40–60% SDM from raw slurry (Jorgensen and Jensen, 2009), which in turn will enhance the infiltration of dissolved and suspended slurry constituents and thus influence the leaching process. Soluble and suspended slurry particles (>20% of total SDM) usually remain in the liquid fraction after separation (Burton, 2007), and organic constituents may facilitate transport of contaminants in soils (Guber et al., 2007b; Guber et al., 2005; Cheng et al., 2007; Cao et al., 2010). Chemical treatment of slurry may also have an effect on the survival of microorganisms (Wu et al., 1998), and on the size distribution of slurry particles. Investigating the effect of slurry pre-treatment on the leaching potential of manure-borne contaminants is, therefore, important (Bolado-Rodriguez et al., 2010).

We quantified the leaching potential (amount of contaminants leached relative to amount applied with slurry after four irrigation events) of *Salmonella* Typhimurium Bacteriophage 28B (phage) as a model organism for viruses, and *Escherichia coli* (*E. coli*) and *Enterococcus* spp. as model organisms for pathogenic bacteria from land-applied pig slurry. The accumulation and leaching of mineral N were also monitored as a measure of net N mineralization and nitrification activity. Leaching experiments were conducted that involved three slurry types and two slurry application methods. We hypothesized that (i) solid-liquid separation may increase the leaching potential of the contaminants in the liquid fraction compared to the raw slurry due to a higher potential exposure to percolating water; (ii) ozonation of the liquid fraction will decrease the leaching potential of all pathogens due to lower survival; and (iii) slurry direct injection will increase the leaching potential of pathogens compared to surface application due to a better survival in the injected slurry.

MATERIALS AND METHODS

Soils. Intact soil columns of a loamy sand were sampled from a crop rotation with spring barley-winter wheat-spring barley at Foulum Experimental Station (56° 29' N, 9° 34' E), Denmark. The plot had not received any animal manure in the previous two years. Sampling was done using stainless steel cylinders (length: 20 cm; diam.: 20 cm) as described previously (Glaesner et al., 2011a). The soil columns were slowly saturated and then drained to a soil water potential of -100 hPa, i.e., close to field capacity for this soil. Then the soil columns were sealed and stored at 2°C until used in the experiment. Selected soil characteristics, determined by standard laboratory methods (Amin et al., 2011), are presented in Table 1.

Slurries. Raw slurry (RS) and the liquid fraction of mechanically separated slurry (LS) were collected at a pig farm near Åbøl, Denmark. A 10-L portion of LS was ozonated at Research Centre Foulum, Denmark by supplementing ozone at 0.125 L min⁻¹ until the redox potential reached zero. Slurry samples were stored in blue-cap bottles at 2°C prior to application to columns. Selected physicochemical properties of RS, LS, and the ozonated liquid fraction (OLS) are presented in Table 2.

Prior to application all slurries were spiked with phage (1.5×10^6 PFU ml⁻¹) as a model organism for pathogenic virus, and with 2,6-difluorobenzoic acid (FBA, CAS RN 385-00-2, Sigma-Aldrich, Germany) (2 g l⁻¹) as a non-reactive tracer. The toxicity of FBA on selected microorganisms was tested before starting the experiment, and no significant effect was found at the concentration used. A similar result was reported by McCarthy et al. (2000).

Experimental design. All glassware and devices used were sterilized. The experiment was conducted at 10°C. Soil columns, slurries, and rain water were equilibrated to the experimental temperature before use.

For the leaching experiment hexaplicate columns were amended with RS by simulated surface application and subsurface injection, respectively. The treated slurry materials LS and OLS were also added to hexaplicate columns, but by subsurface injection only. The slurries were applied at a rate of 50 t ha^{-1} . Injected slurry was placed in a slit with a dimensions $10 \text{ (length)} \times 4 \text{ (width)} \times 9 \text{ (depth)} \text{ cm}^3$ created at the centre of the column surface (Fig. 1). For surface application the slurry was applied in a band created by removing the top 2 cm soil from a circular area of 17 cm diameter in the centre of the column surface. Soil removed from the column was subsequently used to cover the slit/band loosely after slurry application.

As controls triplicate columns with subsurface injection of RS and LS were prepared that were not irrigated in order to examine the redistribution and fate of microorganisms and mineral N as affected by differences in SDM only. Also, triplicate soil columns without slurry amendment, but with irrigation, were included.

For all except non-irrigated samples there were four separate irrigation events (IE) to simulate rainfall, which occurred 1, 2, 3 and 4 weeks after slurry application. The initial one-week between slurry application and IE1 was chosen to simulate conditions in the field where slurry is typically applied during a dry spell in spring. Artificial rainwater (0.1mM NaCl, 0.01mM CaCl₂ (2H₂O), and 0.01mM MgCl₂ (6H₂O) (VWR, Denmark)) at 10 mm h^{-1} was applied using a rain simulator (Laegdsmand et al., 2009; Glaesner et al., 2011a). During these events the soil columns with or without slurry rested on a glass filter disc of 60–100 μm pore size and 1.6 cm thickness (ROBU, Glassfiltergerate GMBH, Germany). The glass filter disc was mounted on top of a stainless steel plate securing a small space between them, which was water-filled during the experiment. At the bottom of the water-filled space, a water-filled hypodermic needle leads the leachate to a blue-cap bottle. The water-filled space and a hanging water column in the hypodermic needle exerted a suction of -12.5 hPa on the soil column's lower boundary to allow leaching under unsaturated soil

conditions (Laegdsmand et al., 2005). The adsorption and filtration properties of the below-column setup were tested to ensure that microorganisms leached from the soil columns would reach the blue-cap bottles. The concentrations of microorganisms in in-flow and out-flow of the below-column setup were similar.

Water and soil sampling. Leachates were collected when percolation had stopped after each irrigation event (IE). A week after the final irrigation event, IE4, the soil columns were extruded slowly using a pressing device, and sectioned to isolate the original slurry hotspot (S1) and three other subsamples (S2, S3 and S4) as indicated in Fig. 1. Immediately after collection, samples were prepared and analyzed for the selected contaminants.

Physicochemical analyses. Electrical conductivity (EC) and pH of both soil samples and leachates were measured with a Radiometer conductivity-meter (Copenhagen, Denmark) and Sentron 3001 pH-meter (Roden, The Netherlands), respectively. Subsamples were extracted in 1 M KCl. After filtration (GA55; Advantec, Japan) these extracts, as well as leachates, were analyzed for NH₄-N and NO₃-N on an Auto-analyzer III Digital Colorimeter (Bran & Luebbe, Germany). Turbidity was measured on a HACH 2100 AN turbidimeter equipped with an EPA filter measuring at wavelengths 400–600 nm (Hach, Loreland, CO). Total organic carbon (TOC) in the leachates was analyzed by a total organic carbon analyzer (TOC-V_{CPH}, Shimadzu, Duisburg, Germany). FBA concentrations in the leachates were measured by a LC-MS/MS technique as described by Juhler and Mortensen (2002).

Microbial analyses

Phage. Phage was enumerated by a double-agar layer method (Adams, 1959). The host strain *Salmonella* Typhimurium Type 5 was grown in nutrient broth at 37°C for four hours. Approximately two g soil was added to 18 ml Maximum Recovery Diluent (MRD, Oxoid, Denmark) and sonicated for 30 s. Soil samples were then 10-fold diluted in MRD, and fresh

leachates were also diluted similarly. One ml diluted sample was mixed with one ml broth culture of the host strain and three ml soft agar (a mixture of 70% Blood agar base (Oxoid, Denmark) and 30% Nutrient broth (Oxoid, Denmark)). The mixture was spread on a well-dried Blood agar base plate and incubated at 37°C for 18 h. Clear zones (plaques) were counted as PFU. The detection limit for phage was 10 PFU g⁻¹ for soil and 1 PFU ml⁻¹ for leachates.

***E. coli*, plate counts.** Two g of freshly sieved soil was mixed with 18 ml of 0.01 M phosphate buffer in a glass tube followed by sonication for 20 s (Aagot et al., 2001; Vail et al., 2003). Ten-fold dilution series were prepared for both soil and leachates samples, and the diluted samples were plated in triplicate on *E. coli* Petrifilms (3M a/s, Denmark). After incubation at 37°C for 24 hours, characteristic blue colonies were counted as *E. coli* (CFU). The detection limit for *E. coli* was 10 CFU g⁻¹ for soil and 1 CFU ml⁻¹ for leachates.

***E. coli*, DNA extraction.** One hundred ml of each leachate sample was filtrated using a 0.2 µm pore size polycarbonate filter membrane (GE Osmonics Labstore, Minnetonka, MN, USA) under low suction. The filter membrane was cut into small pieces and then mixed with 0.5 ml of cetyl trimethylammonium bromide extraction buffer, 0.5 ml of phenol-chloroform-isoamyl alcohol (25:24:1 pH 8.0), and 250 mg of ziconia/silica beads and vortexed for 30 s. The mixture was centrifuged at 13000 ×g for 10 min, and the aqueous phase then transferred to an eppendorf tube. The aqueous phase was separated from phenol by adding an equal volume of chloroform-isoamyl alcohol (24:1) and centrifuging at 13000×g for 5 min. The DNA was precipitated by adding cold ammonium acetate and isopropanol and then centrifuging at 13000 ×g for 10 min. The DNA pellet was washed once with ice cold 70% ethanol and air-dried, and then 25-µl DNase-free water was added. The prepared DNA was used immediately or stored at -20 °C until used.

The gene malate dehydrogenase (*mdH*) of *E. coli* was chosen for quantitative real-time PCR (qPCR). The specificity of this gene was confirmed by qPCR assays, and it was also ensured that

false-positive results or cross-contaminations were absent. The primers were designed by PRIMER3 (<http://frodo.wi.mit.edu/primer3/>) with the sequences: mdh1 (forward primer)–TGCACGTTTTGGTCTGTCTC and mdh2 (reverse primer)–AGAAGAAACGGGCGTACTGA. The primers were synthesized by DNA-Technology Company A/S (Aarhus, Denmark). The qPCR assays were carried out in an Mx3005P thermocycler (Stratagene, Denmark) using *mdh* primers. The PCR mixtures (25 μ l) contained 5 μ l DNA, 12.5 μ l of 2 \times PCR master mix (Promega, Denmark), 400 nM of each primer and 50000x diluted SYBR green (Invitrogen, Denmark). The qPCR conditions consist of an initial heat-denaturing step at 94°C for 5 min; followed by 45 cycles of 94°C for 15 s, annealing at 56°C for 20 s, and extended at 72°C for 20 s; followed by an elongation step at 72°C for 3 min. In every qPCR assay, the *E. coli* standard curve was included in duplicate for absolute quantification. Furthermore, a negative control (5 μ l of water) and a positive DNA control (5 μ l) of *E. coli* DNA (2 ng μ l⁻¹) were included.

***Enterococcus* spp.** Both soil and leachate samples were diluted in MRD as described for phage dilution. One ml diluted sample was spread on Slanetz and Bartley Medium (Oxoid, Denmark). The number of *Enterococcus* spp. was determined as typical red-maroon colonies on the Slanetz and Bartley Medium following incubation at 44°C for 48 \pm 4 h (DS 2401, 1999). The detection limit for *Enterococcus* spp. was 10 CFU g⁻¹ for soil and 1 CFU ml⁻¹ for leachates.

Statistical analysis. The statistical software R was used for statistical analyses (R Development Core Team, 2009). Analysis of variance (ANOVA) of the data was carried out at the 95% confidence level to evaluate differences in leaching of the contaminants and slurry constituents between different treatments.

RESULTS AND DISCUSSION

In this study, effects of slurry distribution, pre-treatment, and simulated rainfall on the leaching of model microorganisms and mineral N were investigated. We first present the distribution and

persistence of contaminants in soil without irrigation after five weeks. Then effects of slurry pretreatment by solid-liquid separation, or separation combined with ozonation are presented, and finally the effects of applying slurry to the soil surface as opposed to subsurface injection.

Effect of slurry type, without irrigation. Figure 2a (upper panels) shows the distribution of contaminants and physicochemical variables among the four sections of columns after five weeks with injection of LS or RS, but without irrigation. The within-column distribution of contaminants among the four soil sections are presented as percentages of the total recovered in soil in each column to account for between-sample variability. The percentage of the remaining microorganisms and mineral N in the slurry injection zone, S1, was higher with RS compared to LS, whereas it was higher in S2 and S3 with LS (Fig. 2a). This suggests that the slurry with pathogens and mineral N distributed further into the soil with LS compared to RS. *E. coli* and *Enterococcus* spp. were only recovered in section S1 after application with RS. The main difference between RS and LS was the lower concentration of total and volatile solids in the latter (Table 2), which probably promoted infiltration of the slurry components away from the injection slit. During solid-liquid separation larger particles are generally removed first, and thus particles remaining in LS should be finer and more mobile than those of RS (Hjorth et al., 2010). A higher proportion of mobile to immobile particles in LS compared to RS can increase particle-mediated transport of contaminants. Unc and Goss (2004) and Pachepsky et al. (2006) suggested a similar mechanism for the organic matter-facilitated transport of microorganisms.

The presence of slurry has been found to increase the soil water content (SWC) (Olesen et al., 1997), and a relationship has been found between slurry organic matter (volatile solids) and the proportion of the liquid phase retained in slurry slit that also depends on SWC at the time of application (Petersen et al., 2003). In accordance with this, SWC and electrical conductivity (EC) in S1 were significantly higher than in the other sections with both slurries (Fig. 2).

The different patterns of redistribution of the slurries significantly influenced the survival of microorganisms. Total retention in soil columns and overall recoveries of the contaminants are presented as percentages of the total applied in the slurry materials. The recovery of phage was similar for LS and RS, whereas recoveries of *E. coli* and *Enterococcus* spp. were higher with LS (Table 3). The overall lowest recovery (0.7%) among all contaminants was observed for *E. coli* in RS, and the highest recovery (35%) also for *E. coli* in LS. Greater infiltration of *E. coli* with LS would represent a change in environment, whereas the retention in a slurry saturated volume, as with RS, would represent an environment more similar to the original slurry. This indicates that *E. coli* was surviving better in the new environment of the soil. It could be relevant to state that *E. coli* and *Enterococcus* spp. are both facultative anaerobes. It suggests that the physical protection obtained when organisms are carried with infiltrating water towards the smaller pores may be an important factor in determining survival.

The percentages of surviving microorganisms recovered in S2–S4 followed the order *Enterococcus* spp. < *E. coli* < phage. Movement of microorganisms as the slurry infiltrates into the soil after application will be impeded by physical straining and chemical attachment in the soil (Torkzaban et al., 2006; Bradford et al., 2006), so size, shape and chain formation are important for their transport in soil. *Enterococcus* spp. cells are spherical and approximately 0.5–1 µm (Kokkinos et al., 1998), but the cells are organized in chains; *E. coli* cells are rod shaped and of 0.7–1.5 µm size (McClain et al., 2001; Pachepsky et al., 2006); and phages are circular with a diameter of 0.03–0.07 µm (Schijven et al., 2002). This may explain why the phage was more mobile in soil followed by *E. coli*, while *Enterococcus* spp. had lowest mobility due to the chain organization.

Effects of slurry pre-treatment, with irrigation. LS had a higher leaching potential of mineral N, *E. coli*, phage, and total organic carbon (TOC) compared to RS, whereas the leaching potential of *Enterococcus* spp. was similar with the two slurry types (Table 3). Leaching potentials of the

contaminants are presented as percentages of the total applied in the slurry materials. Ozone treatment did not affect the leaching potential of any contaminant except *E. coli*. Probably the survival of only *E. coli* was significantly affected by ozone treatment. Nitrate constituted between 92 and > 99% of total mineral N in leachates, the concentrations ranging from 12 to 65 mg L⁻¹. Nitrogen equivalent to 13–24% of the mineral N applied in slurry leached from the columns during the experiment. The leaching potential of phage (10–16%) was higher than that of both culturable *E. coli* (0.1–0.6%) and *Enterococcus* spp. (0.1–0.2%) with all three slurry types (Table 3). This corresponds with the findings from the non-irrigated columns where phage moved further into the soil after application of slurry followed by *E. coli* and *Enterococcus* spp.

In contrast to the plate counts of *E. coli*, there were no differences in the leaching of *E. coli* when evaluated using qPCR based on *mdh* DNA copy numbers, neither between LS and RS nor between LS and OLS (Table 3). Contrary to the plate count results, the *mdh* genes were below the detection limit in leachates from IE4. A steady decrease in *E. coli* levels was observed in the leachates throughout the experiment with both plate counting (Fig. 3) and qPCR. The concentration of culturable *E. coli* in the leachate decreased two-fold between IE1 and IE4, and the concentration of DNA two-fold. The temporal trends of *E. coli* leaching were apparently similar for both enumeration techniques. A significant difference ($p < 0.001$) was observed between the DNA quantification (culturable and non-culturable or dead cells) and plating-based CFUs (culturable cells) of *E. coli* in the leachates during IE1–IE3, which indicates that many non-culturable or dead cells of *E. coli* leached with culturable *E. coli*. The result is in agreement with Pedersen and Jacobsen (1993) who found a significant difference between the CFUs and DNA levels when investigating the survival of microorganisms in an air-dried soil. It is possible that some of this DNA actually derives from dead cells in manure and soil. However, it has been argued that the half-

life of DNA in environmental samples may be very short because of the presence of nucleases (Leo et al., 2005; Lorenz and Wackernagel, 1994; Wery et al., 2006).

The leaching potentials of all contaminants changed significantly with time. The leaching of mineral N increased with all three slurry types (Fig. 3), probably reflecting $\text{NO}_3\text{-N}$ accumulation via nitrification. In contrast, the leaching of all microorganisms decreased rapidly with time, presumably due to inactivation, depletion, and filtering in the soil (Fig. 3). The leaching potential of phage from RS was lower than that from LS only during IE1.

With LS there was a higher leaching potential in the first IE of all contaminants compared to RS (Fig. 3). The breakthrough curves of the non-reactive tracer, FBA, the EC, TOC, and turbidity also showed higher concentrations in the leachate of IE1 when LS was applied compared to with RS. This indicates that there is a general delay of the slurry constituents with RS compared to LS probably originating from a lower infiltration of RS into the soil after application. With both LS and OLS, the FBA leaching peaked during IE1, whereas the tracer peaked during IE2 in columns amended with RS. Total amounts of FBA leached were similar with all slurry types (Table 3). The leaching of TOC was only slightly delayed relative to the breakthrough of FBA in all treatments (Fig. 3). Dunnivant et al. (1992) suggested that leaching of TOC can be delayed with an extended long tail due to slow and nonlinear adsorption to soil particles. The electrical conductivities (EC) of leachates from LS and OLS treatments were higher compared to RS during IE2–IE4. Since the initial contents of salts in the three slurry types were identical, it indicates a greater contact between the salts from the liquid slurries and the infiltrating water (Fig. 3). A high turbidity of the leachate from the RS treatment was observed during IE3 which may have resulted from disintegration of soil aggregates and release of soil colloids due to the higher water content in S1 (Fig. 3).

Both retention and overall recovery of *Enterococcus* spp. were similar with all three slurry types (Table 3). Phage retention was higher for RS than that for LS or OLS; this was due to less leaching

of phage with RS as the overall recoveries for RS, LS and OLS were similar (Table 3). Both retention and recovery of *E. coli* was higher for LS than for RS because of the higher survival with LS that was also observed in the non-irrigated columns (Table 3). *E. coli* recovery was lower with OLS than with LS, indicating that survival was reduced by the ozone treatment (Table 3). Recovery of *Enterococcus* spp. was similar among slurry treatments, but perhaps survival was slightly affected by ozonation as none leached after IE1 (Fig. 3). With all slurry types between 80 and 99% of total remaining *Enterococcus* spp. were recovered in S1 after the incubation with four leaching events (Fig. 2b), indicating a very low mobility that could be due to higher attachment on the solids of the slurry, chain organization of the cells or poor survival outside the slurry hotspot. Microorganisms filtered out in larger pore spaces could be more exposed to predators. Guber et al. (2007a) reported that the release of *Enterococcus* spp. from slurry particles was significantly lower than that of *E. coli*, and they argued that *Enterococcus* spp. were predominantly attached to solid particles in the manure.

Total mineral N recoveries in irrigated columns were lower than recoveries in non-irrigated columns (Table 3). In contrast, total microorganisms recovered in non-irrigated columns were lower compared to the total recovery in irrigated condition except *E. coli* in LS. The inactivation of microorganisms was lower in the relatively wet soil of irrigated columns as shown by the higher soil-recovery of *Enterococcus* spp. Leaching during the early irrigation events also led to higher recovery in irrigated columns due to a general inactivation with time as indicated by the recovery of phage (Fig. 3 and Table 3). With mineral N the opposite is the case. It was not clear why mineral N recovered in irrigated columns was lower than the remaining mineral N in non-irrigated columns. Short-chain fatty acids are the main constituent of DOC in slurry (Paul and Beauchamp, 1989), and redistribution of DOC during irrigation events may have stimulated N immobilization and denitrification (Sexstone et al., 1985; Sorensen, 1998).

Effect of application method, with irrigation. Leachate composition with surface application and sub-surface injection of RS are presented in Fig. 4. Injection increased the leaching potential of phage, *E. coli* and *Enterococcus* spp. significantly compared to surface application, both with respect to culturable cells and DNA (Table 3). Bech et al. (2011) reported that the average proportion of *Salmonella enterica* leached was 6.1% after injection and 0.6% after surface application on silt loam soil, but the difference was not significant due to high variability among replicates. Injection did not influence the amount of mineral N leached during our experiment (Table 3).

Surface application reduced leaching of microorganisms compared to injection after all IEs (Fig. 4). The leaching of mineral N in the beginning of the experiment was low for surface application, which was compensated by equal or even higher leaching in some columns at the end compared to injection (Fig. 4). This was not the case for microorganisms, probably due to the higher rate of inactivation and greater potential for attachment and straining related retardation in the soil during transport.

The shorter leaching path with slurry injection most likely accelerated the emergence of all contaminants in the leachate (Fig. 4). The breakthroughs of FBA and TOC with the two application methods supported the leaching patterns of the contaminants; the elution of FBA in IE1 for surface application of slurry was lower than that for injection. But although surface application delayed the peak of both FBA and TOC (Fig. 4), the cumulated leaching of both FBA and TOC was similar for the two application methods (Table 3).

Possibly a difference in survival rates could explain the differences in leaching potential between application methods. The exposure to desiccation at the surface of the column can reduce the overall survival of microorganisms after surface application. Phage and *Enterococcus* spp. recoveries were higher when applied by injection. The relatively higher leaching in early IEs for

injection where inactivation was still low may have been the major factor in explaining the higher recovery. An average of 1.6 and 2.7% of total applied *E. coli* were recovered for surface application and injection, respectively; however, the difference was not significant (Table 3).

The relative amount of the remaining microorganisms in sections S2–S4 was either higher for injection than surface application or similar for the two application methods except for phage in S2 (Fig. 2). *E. coli* (75–90%) and *Enterococcus* spp. (90–94%) mainly remained in S1 for both application methods because of the low mobility and/or low survival.

General discussion. Gannon et al. (1991) reported that cell size of microorganisms is the main factor controlling transport in repacked soil. Irrespective of slurry treatment, the leaching potential of *Enterococcus* spp. was lower than that of *E. coli*, but leaching of the phage was considerably higher than that of both bacteria (Table 3). The leaching of *E. coli* would be reduced due to the rod shape (Salerno et al., 2006), but our study showed an increased transport of *E. coli* compared to *Enterococcus* spp. Stronger attachment of the latter to slurry particles, as indicated by Guber et al. (2007a), or the organization of cells in chains could be reasons for the lower movement in soil. Following redistribution of slurry a proportion of the organisms could be deposited at the surface of macropores where they may be exposed to water stress. This tends to make cells more spherical (Markova et al., 2010), which could explain the higher leaching potential of *E. coli*. Leaching of *E. coli* and *Enterococcus* spp. was primarily observed during IE1, but high variability among replicate columns indicated that the transport in soil occurred mainly in connection with macropore flow. Presumably bacteria that ended up in the active macropore flow path by the initial redistribution process were eluted during IE1. After IE1 this organism was detected in only a few leachates out of 6 replicates and for only LS and RS.

Few or no bacteria leached during the fourth IE despite the fact that a considerable amount of bacteria, 1.6–12% for *E. coli* and 4.1–17% for *Enterococcus* spp., still remained in the columns

(Table 3). The highest concentration of *Enterococcus* spp. in the leachates was below 10 CFU ml⁻¹, and this bacterium did not leach after IE1 for surface applied RS and injected OLS. The remaining bacteria were presumably tightly attached or strained between particles or remained in non-flow zone, so that infiltrating water could not release and transport them. Moreover, the remaining slurry solids possibly reduced the permeability of S1 where most of the bacteria remained. With both application methods and all slurry types EC and SWC in S1 remained higher than the background values (Fig. 2), showing that the characteristics of the injection slit environment were partly maintained even after four IEs.

The survival of the microorganisms investigated generally followed the order of *E. coli* < *Enterococcus* spp. < phage. In accordance with this, the phages survived longer than *E. coli* in slurry treated soils in a field study (Amin et al., 2011). Also, *Enterococcus* spp. remained viable longer than *E. coli* in soil-slurry mixtures of an experiment by Cools et al. (2001), who studied the survival of *E. coli* and *Enterococcus* spp. from pig slurry applied to soil. They found that low temperature (5°C vs. 15 and 25°C), as well as high moisture content (field capacity vs. drier soil), improved survival of these organisms. The relatively low incubation temperature of 10°C in our experiment may also have helped the organisms survive.

The leaching of bacteria in the current study was low compared to other studies (e.g., Mosaddeghi et al., 2009). There may be several reasons for this. Firstly, the slurry was applied to soil at field capacity (normal agricultural practice) and secondly, the first irrigation event took place one week after slurry application, which in turn provided time for redistribution and inactivation. During the redistribution process in the relatively dry soil, microorganisms could have reached relatively fine pore spaces protected from infiltrating water in active flow path. Finally, the bacteria (*E. coli* and *Enterococcus* spp.) endogenous to the applied slurry were probably more strongly attached to slurry

components than the phage which was introduced shortly before slurry application. The inactivation rate may also be expected to be higher in comparison to other experimental studies where slurry samples or microorganisms with irrigating water were applied to wet soil, and/or irrigation was applied instantly (Mosaddeghi et al., 2009; Shelton et al., 2003; Mosaddeghi et al., 2010). Our results thus support that the slurry application to relatively dry soil and in the beginning of a dry spell can reduce the risk of bacteria leaching.

The leaching potential of different application methods may vary with soil structure. The extent of soil-slurry mixing during application is of fundamental importance in controlling the leaching potentials because a better incorporation of slurry into the bulk soil can place major portion of contaminants away from the active macropore flow paths (Glaesner et al., 2011b). On the other hand, greater redistribution of slurry constituents in a soil with few preferential flow paths may increase the interaction between matrix flow and contaminants and hence leaching. Surface application, being less expensive (Hadrich et al., 2010) and less risky with regard to contaminant leaching, may be the best choice for loamy soil types, especially for dilute slurries and for the fields with no risks of surface runoff.

Conclusions. Initial convective redistribution of slurry constituents after slurry application was more pronounced when using the liquid fraction of slurry after solid-liquid separation compared to raw slurry. More TOC, mineral N, phage, and *E. coli* leached during four leaching events after application of liquid fractions. Ozonation, which may reduce the amount of pathogens in the slurry, did not reduce the potential of these pathogens to leach except for *E. coli*. Reduced leaching depth with injection and slightly higher survival of the microorganisms in injected slurry probably enhanced the leaching potential of the microorganisms compared to surface application. Bacteria, virus and nitrate still showed a significant leaching potential even though slurry was applied to soil

at around field capacity and in the beginning of a one-week dry spell. In a risk assessment and management perspective it is necessary to take into account these factors, and knowledge about the effects on the leaching potentials provides a basis for improving slurry management technologies.

ACKNOWLEDGEMENTS

This study was supported by the Pathos Project funded by the Strategic Research Council of Denmark (ENV 2104-07-0015) and Grundfoss New Business A/S. We thank Michael Koppelgaard, Stig Rasmussen, Palle Jorgensen, and Maibritt Hjorth from Faculty of Science and Technology of Aarhus University, Denmark for their help during sampling and laboratory analysis. We appreciate the technical assistance of Nina Flindt and Gitte Petersen from Faculty of Life Science, University of Copenhagen, Denmark.

REFERENCES

1. **Aagot, N., O. Nybroe, P. Nielsen, and K. Johnsen.** 2001. An altered *Pseudomonas* diversity is recovered from soil by using nutrient-poor *Pseudomonas*-selective soil extract media. *Appl. Environ. Microbiol.* **67**:5233–5239.
2. **Adams, M.H.** 1959. *Bacteriophages*, Interscience Publishers, New York.
3. **Albihn, A. and B. Vinneras.** 2007. Biosecurity and arable use of manure and biowaste - Treatment alternatives. *Livest. Sci.* **112**:232–239.
4. **Amin, M. G. M., T. B. Bech, A. Forslund, M. Hansen, S. O. Petersen, and M. Lægdsmand.** 2011. Redistribution and persistence of microorganisms and steroid hormones after soil-injection of slurry. (Submitted)

5. **Bech, T., A. Dalsgaard, O. S. Jacobsen, and C. S. Jacobsen.** 2011. Leaching of Salmonella enterica in Clay Columns Comparing Two Manure Application Methods. *Ground Water* **49**:32–42.
6. **Bech, T. B., K. Johnsen, A. Dalsgaard, M. Laegdsmand, O. H. Jacobsen, and C. S. Jacobsen.** 2010. Transport and Distribution of Salmonella enterica Serovar Typhimurium in Loamy and Sandy Soil Monoliths with Applied Liquid Manure. *Appl. Environ. Microbiol.* **76**:710–714.
7. **Bolado-Rodriguez, S., D. Garcia-Sinovas, and J. Alvarez-Benedi.** 2010. Application of pig slurry to soils. Effect of air stripping treatment on nitrogen and TOC leaching. *J. Environ. Manage.* **91**:2594–2598.
8. **Bradford, S. A., J. Simunek, and S. L. Walker.** 2006. Transport and straining of *E. coli* O157:H7 in saturated porous media, *Water Resour. Res.* **42**:W12S12.
9. **Burton, C. H.** 2007. The potential contribution of separation technologies to the management of livestock manure. *Livest. Sci.* **112**:208–216.
10. **Cameron, K. C., A. W. Rate, M. J. Noonan, S. Moore, N. P. Smith, and L. E. Kerr.** 1996. Lysimeter study of the fate of nutrients following subsurface injection and surface application of dairy pond sludge to pasture. *Agric. Ecosys. Environ.* **58**:187–197.
11. **Cao, H. B., F. T. C. Tsai, and K. A. Rusch.** 2010. Salinity and Soluble Organic Matter on Virus Sorption in Sand and Soil Columns. *Ground Water* **48**:42–52.
12. **Cheng, L., A. S. Chetochine, I. L. Pepper, and M. L. Brusseau.** 2007. Influence of DOC on MS-2 bacteriophage transport in a sandy soil. *Water Air Soil Pollut.* **178**:315–322.

13. **Cools, D., R. Merckx, K. Vlassak, and J. Verhaegen.** 2001. Survival of *E. coli* and *Enterococcus* spp. derived from pig slurry in soils of different texture. *Appl. Soil Ecol.* **17**:53–62.
14. **DS 2401.** 1999. Environmental quality–Enumeration of enterococci–Colony count on solid medium–Spread plate method. Danish Standard.
15. **Dunnivant, F. M., P. M. Jardine, D. L. Taylor, and J. F. McCarthy.** 1992. Transport of Naturally-Occurring Dissolved Organic-Carbon in Laboratory Columns Containing Aquifer Material. *Soil Sci. Soc. Ame. J.* **56**:437–444.
16. **Franz, E. and A. H. C. van Bruggen.** 2008. Ecology of *E. coli* O157:H7 and *Salmonella enterica* in the Primary Vegetable Production Chain. *Crit. Rev. Microbiol.* **34**:143–161.
17. **Gannon, J. T., V. B. Manilal, and M. Alexander.** 1991. Relationship Between Cell-Surface Properties and Transport of Bacteria Through Soil. *Appl. Environ. Microbiol.* **57**:190–193.
18. **Glaesner, N., C. Kjaergaard, G. H. Rubaek, and J. Magid.** 2011. Interactions between Soil Texture and Placement of Dairy Slurry Application: I. Flow Characteristics and Leaching of Nonreactive Components. *J. Environ. Qual.* **40**:337–343.
19. **Glaesner, N., C. Kjaergaard, G. H. Rubaek, and J. Magid.** 2011. Interactions between Soil Texture and Placement of Dairy Slurry Application: II. Leaching of Phosphorus Forms. *J. Environ. Qual.* **40**:344–351.
20. **Guber A. K., J. S. Karns, Y. A. Pachepsky, A. M. Sadeghi, J. S. Van Kessel, and T. H. Dao.** 2007a. Comparison of release and transport of manure-borne *Escherichia coli* and enterococci under grass buffer conditions. *Lett. Appl. Microbiol.* **44**:161-167.

21. **Guber, A. K., Y. A. Pachepsky, D. R. Shelton, and O. Yu.** 2007b. Effect of bovine manure on fecal coliform attachment to soil and soil particles of different sizes. *Appl. Environ. Microbiol.* **73**:3363–3370.
22. **Guber, A. K., Y. A. Pachepsky, D. R. Shelton, and O. Yu.** 2009. Association of Fecal Coliforms With Soil Aggregates: Effect of Water Content and Bovine Manure Application. *Soil Sci.* **174**:543–548
23. **Guber, A. K., D. R. Shelton, and Y. A. Pachepsky.** 2005. Effect of manure on *Escherichia coli* attachment to soil. *J. Environ. Qual.* **34**:2086–2090.
24. **Hadrich, J. C., T. M. Harrigan, and C. A. Wolf.** 2010. Economic Comparison of Liquid Manure Transport and Land Application. *Appl. Engineer. Agric.* **26**:743–758.
25. **Hjorth, M., K. V. Christensen, M. L. Christensen, and S. G. Sommer.** 2010. Solid-liquid separation of animal slurry in theory and practice. A review. *Agron. Sustain. Develop.* **30**:153–180.
26. **Huijsmans, J. F. M., J. M. G. Hol, and G. D. Vermeulen.** 2003. Effect of application method, manure characteristics, weather and field conditions on ammonia volatilization from manure applied to arable land. *Atmos. Environ.* **37**:3669–3680.
27. **Juhler, R. K. and A. P. Mortensen.** 2002. Analysing fluorobenzoate tracers in groundwater samples using liquid chromatography-tandem mass spectrometry - A tool for leaching studies and hydrology. *J. Chromatogr. A* **957**:11–16.

28. **Jorgensen, K. and L. S. Jensen.** 2009. Chemical and biochemical variation in animal manure solids separated using different commercial separation technologies. *Biores. Technol.* **100**:3088–3096.
29. **Kokkinos, A., C. Fasseas, E. Eliopoulos, and G. Kalantzopoulos.** 1998. Cell size of various lactic acid bacteria as determined by scanning electron microscope and image analysis. *Lait* **78**:491-500.
30. **Laegdsmand, M., H. Andersen, O. H. Jacobsen, and B. Halling-Sorensen.** 2009. Transport and Fate of Estrogenic Hormones in Slurry-treated Soil Monoliths. *J. Environ. Qual.* **38**:955–964.
31. **Laegdsmand, M., L. W. De Jonge, and P. Moldrup.** 2005. Leaching of colloids and dissolved organic matter from columns packed with natural soil aggregates. *Soil Sci.* **170**:13–27.
32. **Lee, L. S., N. Carmosini, S. A. Sassman, H. M. Dion, and M. S. Sepulveda.** 2007. Agricultural contributions of antimicrobials and hormones on soil and water quality. *Advanc. Agron.* **93**:1–68.
33. **Lleo, M. M., B. Bonato, M. C. Tafi, C. Signoretto, C. Pruzzo, and P. Canepari.** 2005. Molecular vs culture methods for the detection of bacterial faecal indicators in groundwater for human use. *Lett. Appl. Microbiol.* **40**:289–294.
34. **Lorenz, M. G., and W. Wackernagel.** 1994. Bacterial gene transfer by natural genetic transformation in the environment. *Microbiol. Rev.* **58**:563–602.
35. **Mantovi, P., L. Fumagalli, G. P. Beretta, and M. Guermandi.** 2006. Nitrate leaching through the unsaturated zone following pig slurry applications. *J. Hydrol.* **316**:195–212.

36. **Markova, N., G. Slavchev, L. Michailova, and M. Jourdanova.** 2010. Survival of *Escherichia coli* under lethal heat stress by L-form conversion Int. J. Biol. Sci. 2010, **6**: 313–315.
37. **Mawdsley, J. L., R. D. Bardgett, R. J. Merry, B. F. Pain, and M. K. Theodorou.** 1995. Pathogens in livestock waste, their potential for movement through soil and environmental pollution. Appl. Soil Ecol. **2**:1–15.
38. **McCarthy, J. F., K. M. Howard, and L. D. McKay.** 2000. Effect of pH on sorption and transport of fluorobenzoic acid ground water tracers. J. Environ. Qual. **29**:1806–1813.
39. **McClain, M. A., C. T. Culbertson, S. C. Jacobsen, and J. M. Ramsey.** 2001. Flow Cytometry of *Escherichia coli* on microfluidic devices. Analyt. Chem. **73**:5334–5338.
40. **Mosaddeghi, M. R., A. A. Mahboubi, S. Zandsalimi, and A. Unc.** 2009. Influence of organic waste type and soil structure on the bacterial filtration rates in unsaturated intact soil columns. J. Environ. Manage. **90**:730–739.
41. **Mosaddeghi, M. R., A. A. S. Sinegani, M. B. Farhangi, A. A. Mahboubi, and A. Unc.** 2010. Saturated and unsaturated transport of cow manure-borne *Escherichia coli* through in situ clay loam lysimeters. Agric. Ecosyst. Environ. **137**:163–171.
42. **Norring, N. P. and E. Jorgensen.** 2009. Eutrophication and agriculture in Denmark: 20 years of experience and prospects for the future. Hydrobiologia **629**:65–70.
43. **Oenema, O., D. Oudendag, and G. L. Velthof.** 2007. Nutrient losses from manure management in the European Union. Livest. Sci. **112**:261–272.

44. **Olesen, T., P. Moldrup, and K. Henriksen.** 1997. Modeling diffusion and reaction in soils .6. Ion diffusion and water characteristics in organic manure-amended soil. *Soil Sci.* **162**:399–409.
45. **Pachepsky, Y. A., A. M. Sadeghi, S. A. Bradford, D. R. Shelton, A. K. Guber, and T. Dao.** 2006. Transport and fate of manure-borne pathogens: Modeling perspective. *Agric. Water Manage.* **86**:81–92.
46. **Paul, J. W., and E. G. Beauchamp.** 1989. Effect of carbon constituents in manure on denitrification in soil. *Canadian J. Soil Sci.* **69**:49–61.
47. **Pedersen, J. C. and C. S. Jacobsen.** 1993. Fate of *Enterobacter-Cloacae* Jp120 and *Alcaligenes-Eutrophus* Ae0106(Pr0101) in Soil During Water-Stress - Effects on Culturability and Viability. *Appl. Environ. Microbiol.* **59**:1560–1564.
48. **Peters, K., M. Hjorth, L. S. Jensen, and J. Magid.** 2011. Carbon, Nitrogen, and Phosphorus Distribution in Particle Size-Fractionated Separated Pig and Cattle Slurry. *J. Environ. Qual.* **40**:224–232.
49. **Petersen, S. O., H. H. Nissen, I. Lund, and P. Ambus.** 2003. Redistribution of slurry components as influenced by injection method, soil, and slurry properties. *J. Environ. Qual.* **32**:2399–2409.
50. **R Development Core Team.** 2009. R: A language and environment for statistical computing. R Foundation for Statistical Computing, Vienna, Austria. Available at <http://www.R-project.org> (verified 4 May 2011).
51. **Salerno, M. B., M. Flamm, B. E. Logan, and D. Velegol.** 2006. Transport of rodlike colloids through packed beds. *Environ. Sci. Technol.* **40**:6336-6340.

52. **Schijven, J. F., S. M. Hassanizadeh, and R. H. A. M. de Bruin.** 2002. Two-site kinetic modeling of bacteriophages transport through columns of saturated dune sand. *J. Contam. Hydrol.* **57**:259–279.
53. **Sexstone, A. J., T. B. Parkin, J. M. Tiedje.** 1985. Temporal response of soil denitrification rates to rainfall and irrigation. *Soil Sci. Soc. Ame. J.* **49**: 99-103.
54. **Shelton, D. R., Y. A. Pachepsky, A. M. Sadeghi, W. L. Stout, J. S. Karns, and W. J. Gburek.** 2003. Release Rates of Manure-Borne Coliform Bacteria from Data on Leaching through Stony Soil. *Vadose Zone J.* **2**:34–39.
55. **Smiles, D. E.** 1988. Aspects of the Physical-Environment of Soil Organisms. *Biol. Fertil. Soils* **6**:204–215.
56. **Sorensen, P.** 1998. Effects of storage time and straw content of cattle slurry on the mineralization of nitrogen and carbon in soil. *Biol. Fertil. Soils* **27**:85–91.
57. **Torkzaban, S., S. M. Hassanizadeh, J. F. Schijven, H. A. M. de Bruin, and A. M. D. R. Husman.** 2006. Virus transport in saturated and unsaturated sand columns. *Vadose Zone J.* **5**:877–885.
58. **Unc, A. and M. J. Goss.** 2004. Transport of bacteria from manure and protection of water resources. *Appl. Soil Ecol.* **25**:1–18.
59. **Vail, J. H., R. Morgan, C. R. Merino, F. Gonzales, R. Miller, and J. L. Ram.** 2003. Enumeration of waterborne *Escherichia coli* with petrifilm plates: Comparison to standard methods. *J. Environ. Qual.* **32**:368–373.

60. **van Overbeek, L. S., E. Franz, A. V. Semenov, O. J. de Vos, and A. H. C. van Bruggen.** 2010. The effect of the native bacterial community structure on the predictability of E-coli O157:H7 survival in manure-amended soil. *Lett. Appl. Microbiol.* **50**:425–430.
61. **Wery, N., A. M. Pourcher, V. Stan, J. P. Delgenes, F. Picard-Bonnaud, and J. J. Godon.** 2006. Survival of *Listeria monocytogenes* and *Enterococcus faecium* in sludge evaluated by real-time PCR and culture methods. *Lett. Appl. Microbiol.* **43**:131–136.
62. **Webb, J., B. Pain, S. Bittman, and J. Morgan.** 2010. The impacts of manure application methods on emissions of ammonia, nitrous oxide and on crop response--A review. *Agric. Ecosyst. Environ.* **137**:39–46.
63. **Wu, J. J., S. H. Park, S. M. Hengemuehle, M. T. Yokoyama, H. L. Person, and S. J. Masten.** 1998. The effect of storage and ozonation on the physical, chemical, and biological characteristics of swine manure slurries. *Ozone-Sci. Engineer.* **20**:35–50.

Figure Captions

FIG. 1. Sectioning diagram of soil column (S1, slurry slit; S2-S3, surrounding soil; and S4, bottom section of the column).

FIG. 2. Distribution among different sections of total retaining phage, *E. coli*, *Enterococcus* spp. (*Ent. spp.*), and mineral N and the values of soil water content (SWC) and electrical conductivity (EC) of different sections for different slurries of non-irrigated, irrigated and the two application methods after five weeks of the slurry injection (RS, raw slurry; LS, liquid slurry fraction; OLS, ozonated LS; BG, the values obtained without slurry application; S1, slurry slit; S2-S3, surrounding soil; and S4, bottom section of the column).

FIG. 3. Percentage leached of total applied mineral N, phage, *E. coli*, and *Enterococcus* spp. (*Ent.* spp.) and FBA concentration, electrical conductivity (EC), total organic carbon (TOC) concentration, and turbidity of leachates for subsurface-injected three slurry types during four irrigation events over four weeks period (RS, raw slurry; LS, liquid slurry fraction; and OLS, ozonated LS).

FIG. 4. Percentage leached of total applied mineral N, phage, *E. coli*, and *Enterococcus* spp. (*Ent.* spp.) and FBA concentration, electrical conductivity (EC), total organic carbon (TOC) concentration, and turbidity of leachates for sub-surface injection and surface application of raw slurry during four irrigation events over four weeks period.

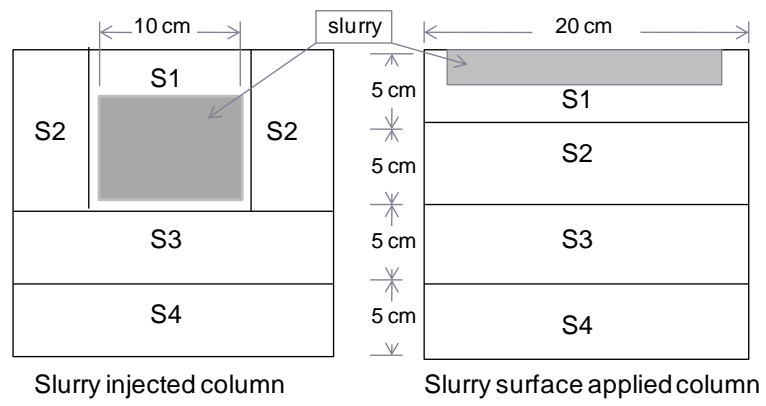

FIG. 1. Sectioning diagram of soil column (S1, slurry slit; S2-S3, surrounding soil; and S4, bottom section of the column).

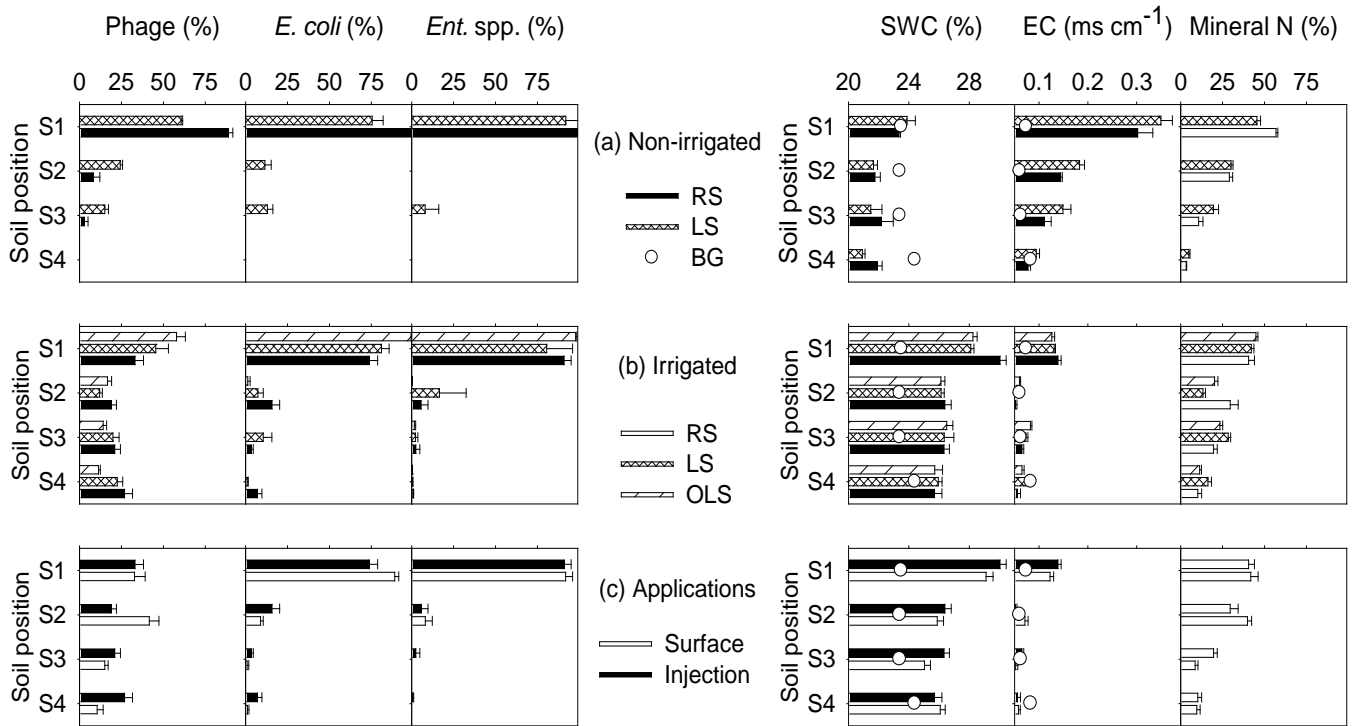

FIG. 2. Distribution among different sections of total retaining phage, *E. coli*, *Enterococcus* spp. (*Ent. spp.*), and mineral N and the values of soil water content (SWC) and electrical conductivity (EC) of different sections for different slurries of non-irrigated, irrigated and the two application methods after five weeks of the slurry injection (RS, raw slurry; LS, liquid slurry fraction; OLS, ozonated LS; BG, the values obtained without slurry application; S1, slurry slit; S2-S3, surrounding soil; and S4, bottom section of the column).

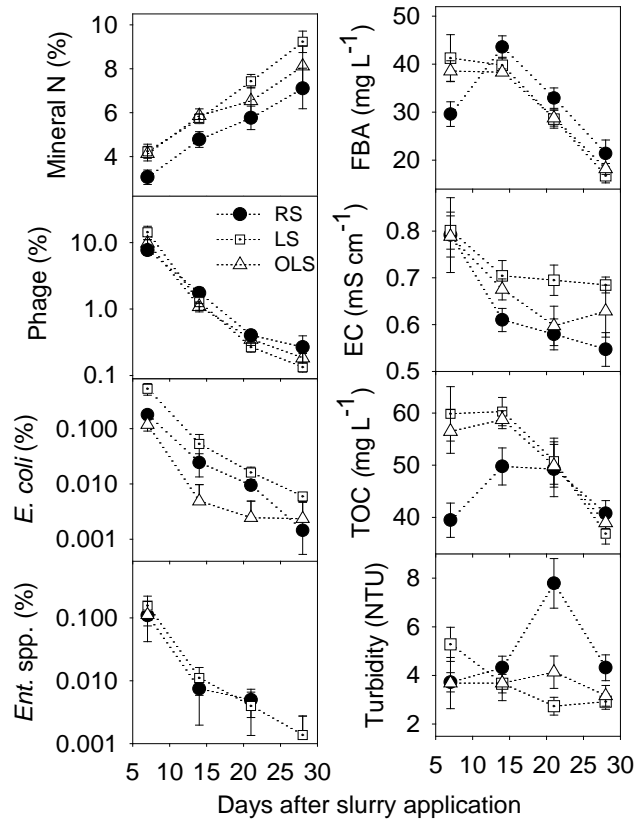

FIG. 3. Percentage leached of total applied mineral N, phage, *E. coli*, and *Enterococcus* spp. (*Ent. spp.*) and FBA concentration, electrical conductivity (EC), total organic carbon (TOC) concentration, and turbidity of leachates for subsurface-injected three slurry types during four irrigation events over four weeks period (RS, raw slurry; LS, liquid slurry fraction; and OLS, ozonated LS).

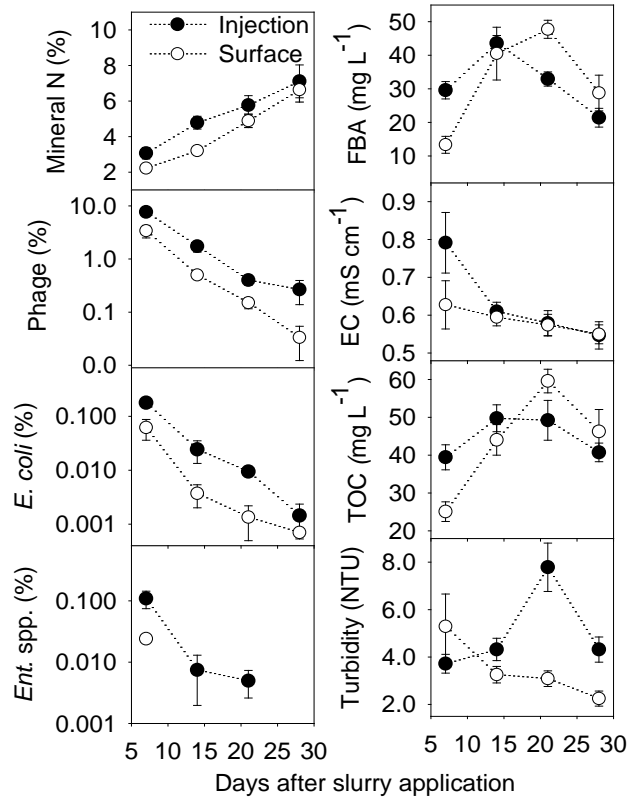

FIG. 4. Percentage leached of total applied mineral N, phage, *E. coli*, and *Enterococcus* spp. (*Ent. spp.*) and FBA concentration, electrical conductivity (EC), total organic carbon (TOC) concentration, and turbidity of leachates for sub-surface injection and surface application of raw slurry during four irrigation events over four weeks period.

TABLE 1. Some selected soil characteristics

Characteristics	Soil depth	
	10 cm	30 cm
OC (%)	2.0	1.8
Porosity	41	43
ρ_d (g cm ⁻³)	1.53	1.49
Clay (%)	8	8
Silt (%)	13	14
Sand (%)	79	78
K_{sat} (mm h ⁻¹)	61.1	43.2
pH	6.33	6.33
EC (mS cm ⁻¹)	0.047	0.047

TABLE 2. Some selected physicochemical properties of different slurries

Characteristics	RS [†]	LS	OLS
Density (g cm ⁻¹)	1.02 ^{j‡}	1.01 ^j	1.00 ^j
Total solids (%)	5.65 ^j	3.14 ^k	3.09 ^k
Volatile solids (%)	4.17 ^j	1.97 ^k	1.90 ^k
pH	7.10 ^j	7.56 ^k	7.86 ^l
EC (mS cm ⁻¹)	19.3 ^j	15.8 ^k	17.9 ^l
NH ₄ -N (g kg ⁻¹)	3.01 ^j	2.89 ^j	3.03 ^j
Total N (g kg ⁻¹)	4.5 ^j	4.3 ^k	4.2 ^k
<i>E. coli</i> (CFU ml ⁻¹)	9.3 × 10 ^{4j}	2.6 × 10 ^{4k}	1.4 × 10 ^{4l}
Phage (PFU ml ⁻¹)	1.8 × 10 ^{6j}	1.8 × 10 ^{6j}	1.8 × 10 ^{6j}
<i>Ent. spp.</i> (CFU ml ⁻¹)	2.9 × 10 ^{4j}	3.2 × 10 ^{4j}	2.7 × 10 ^{4j}

[†] RS, raw slurry; LS, liquid slurry fraction; and OLS, ozonated liquid slurry fraction.

[‡] Different letters (j, k, and l) in superscripts indicate significant difference at 0.05 level.

TABLE 3. Total leached TOC and FBA and the percentage leached and retained of total applied mineral N, phage, *E. coli*, and *Enterococcus* spp. for different treatments

Treatments [†]	Non-irrigated columns		Irrigated columns			
	Subsurface injection		Surface applied	Subsurface injection		
	RS	LS		RS	LS	OLS
FBA (%)	-	-	41.5 ^{e‡} ±3.7	44.1 ^{ej} ±2.7	43.2 ^j ±3.4	42.7 ^j ±1.7
TOC (mg)	-	-	173 ^e ±14	184 ^{ej} ±14	216 ^k ±13	214 ^k ±16
Mineral N						
Leached (%)	-	-	14 ^e ±3	17 ^{ej} ±4	22 ^k ±2	20 ^{jk} ±4
Retained (%)	89 ^{a†} ±5	97 ^a ±5	63 ^e ±3	58 ^{ej} ±8	59 ^j ±5	60 ^j ±6
Recovery (%)	89 ^{a†} ±5	97 ^a ±5	77 ^e ±0.8	75 ^{ej} ±5	81 ^j ±6	80 ^j ±6
Phage						
Leached (%)	-	-	4.1 ^e ±2.3	10.0 ^{fj} ±2.4	15.9 ^k ±8.4	11.4 ^{jk} ±3.1
Retained (%)	3.9 ^a ±1.0	3.1 ^a ±0.6	4.9 ^e ±0.7	5.6 ^{ej} ±2.7	3.1 ^k ±1.3	3.3 ^k ±1.5
Recovery (%)	3.9 ^a ±1.0	3.1 ^a ±0.6	9 ^e ±1.9	15.7 ^{fj} ±1.7	19 ^j ±8.4	14.7 ^j ±2.4
<i>E. coli</i>						
Leached (%)	-	-	0.07 ^e ±0.06	0.21 ^{fj} ±0.09	0.61 ^k ±0.34	0.13 ^j ±0.08
DNA (%)	-	-	8.0 ^e ±5.4	13.5 ^{fj} ±3.1	26.3 ^{jk} ±17.7	37.5 ^k ±24.6
Retained (%)	0.7 ^a ±0.4	35 ^b ±5	1.56 ^e ±1.13	2.53 ^{ej} ±1.89	11.4 ^k ±9.5	2.68 ^j ±1.09
Recovery (%)	0.7 ^a ±0.4	35 ^b ±5	1.63 ^e ±1.2	2.7 ^{ej} ±1.8	12 ^k ±9.3	2.8 ^j ±1.1
<i>Ent. spp.</i>						
Leached (%)	-	-	0.024 ^e ±0.01	0.12 ^{fj} ±0.09	0.17 ^j ±0.17	0.11 ^j ±0.17
Retained (%)	3.5 ^a ±0.4	4.1 ^b ±0.2	4.1 ^e ±1.2	12.4 ^{fj} ±9.6	17.0 ^j ±11.0	10.5 ^j ±8.3
Recovery (%)	3.5 ^a ±0.4	4.1 ^b ±0.2	4.1 ^e ±1.2	12.5 ^{fj} ±9.5	17.2 ^j ±10.9	10.6 ^j ±8.4

[†] RS, raw slurry; LS, liquid slurry fraction; OLS, ozonated liquid slurry fraction; *Ent. spp.*, *Enterococcus* spp.

[‡] Different letters in superscripts indicate significant difference at 0.05 level. Letters a and b are used for RS and LS in non-irrigated columns; e and f are used for application methods with RS; and j, k, and l for slurry types.

Chapter 5: The mechanisms involved in the interactions between *A. castellanii* and *C. jejuni*

This chapter focuses on the mechanisms involved in the interactions between *A. castellanii* and *C. jejuni*. The results of this work have been published at Environmental Microbiology.

Bui XT, Winding A, Qvortrup K, Wolff A, Bang DD and Creuzenet C (2011) **Survival of *Campylobacter jejuni* in co-culture with *Acanthamoeba castellanii*: role of amoeba-mediated depletion of dissolved oxygen. Environ. Microbiol.** doi: 10.1111/j.1462-2920.2011.02655.x (in press)

Survival of *Campylobacter jejuni* in co-culture with *Acanthamoeba castellanii*: role of amoeba-mediated depletion of dissolved oxygen

Xuan Thanh Bui,^{1,5} Anne Winding,² Klaus Qvortrup,³ Anders Wolff,⁴ Dang Duong Bang¹ and Carole Creuzenet^{5*}

¹Laboratory of Applied Micro and Nanotechnology (LAMINATE), National Veterinary Institute (VET), Technical University of Denmark (DTU), Høngøvej 2, DK-8200 Aarhus N, Denmark.

²Department of Environmental Science, Aarhus University, Frederiksborgvej 399, 4000 Roskilde, Denmark.

³Department of Biomedical Sciences, University of Copenhagen, Blegdamsvej 3B, 2200 Copenhagen N, Denmark.

⁴BioLabChip group, DTU-Nanotech (Department of Micro and Nanotechnology), Technical University of Denmark (DTU), Building 345 East, DK-2800 Kgs Lyngby, Denmark.

⁵Department of Microbiology and Immunology, Infectious Diseases Research Group, Dental Sciences Building, Room 3031, University of Western Ontario, London, ON, Canada, N6A 5C1.

Summary

Campylobacter jejuni is a major cause of infectious diarrhoea worldwide but relatively little is known about its ecology. In this study, we examined its interactions with *Acanthamoeba castellanii*, a protozoan suspected to serve as a reservoir for bacterial pathogens. We observed rapid degradation of intracellular *C. jejuni* in *A. castellanii* 5 h post gentamicin treatment at 25°C. Conversely, we found that *A. castellanii* promoted the extracellular growth of *C. jejuni* in co-cultures at 37°C in aerobic conditions. This growth-promoting effect did not require amoebae – bacteria contact. The growth rates observed with or without contact with amoeba were similar to those observed when *C. jejuni* was grown in microaerophilic conditions. Preconditioned media prepared with live or dead amoebae cultivated with or without

C. jejuni did not promote the growth of *C. jejuni* in aerobic conditions. Interestingly, the dissolved oxygen levels of co-cultures with or without amoebae – bacteria contact were much lower than those observed with culture media or with *C. jejuni* alone incubated in aerobic conditions, and were comparable with levels obtained after 24 h of growth of *C. jejuni* under microaerophilic conditions. Our studies identified the depletion of dissolved oxygen by *A. castellanii* as the major contributor for the observed amoeba-mediated growth enhancement.

Introduction

Campylobacter spp. are Gram-negative bacteria that are recognized worldwide as a common cause of acute bacterial enteritis in humans. In developing countries, *Campylobacter* is the bacterial pathogen most commonly isolated from young children with diarrhoea (Coker *et al.*, 2002). At older ages, most cases are usually mild or asymptomatic, probably due to immunity that may follow frequent exposure to contaminated food or water (Allos and Blaser, 1995; Havelaar *et al.*, 2009). However, a serious complication of *Campylobacter jejuni* infection is the development of Guillain – Barré syndrome (GBS), an autoimmune disease affecting the peripheral nervous system, thought to occur in ~1 in 1000 individuals infected with *C. jejuni* (Ang *et al.*, 2000; Yuki, 2001). *Campylobacter jejuni* is also the leading cause of bacterial zoonotic enteric infections in developed countries (Naito *et al.*, 2010). Chickens (Gormley *et al.*, 2008) and livestock animals such as cattle (Inglis *et al.*, 2004; 2005; 2006) and pigs (Zhao *et al.*, 2010) serve as reservoirs for *C. jejuni*, which may be transmitted to humans via contaminated food or water (Korlath *et al.*, 1985; Friedman *et al.*, 2000).

Campylobacter spp. are microaerophilic and have to cope with oxidative stress and the toxic products of oxygen metabolism. However, these organisms are able to survive in food in sufficient numbers to cause infection despite the constraints imposed by this sensitivity to oxygen (Humphrey, 1992). Aero-tolerance has also been reported in a number of studies (Vercellone *et al.*, 1990)

Received 28 July, 2011; accepted 27 October, 2011. *For correspondence. E-mail ccreuzenet@uwo.ca; Tel. (+1) 519 661 3204; Fax (+1) 519 661 3499.

and it has even been suggested that *Campylobacter* spp. can adapt to aerobic metabolism (Jones *et al.*, 1993).

Free-living amoebae can be widely found in environmental matrices such as soil and water, which harbour many bacteria (Schuster, 2002; Marciano-Cabral and Cabral, 2003; Khan, 2006). Specifically, *Acanthamoeba* spp. have been isolated from various water sources, including estuaries, freshwater lakes, rivers, saltwater lakes, beaches and sediment (Khan, 2006). These amoebae interact with the various bacteria present in such environments. The nature of the interactions varies widely, from simple use of the bacteria as food sources for the amoebae (Weekers *et al.*, 1993), to symbiotic relationships that enhance bacterial survival in the environment or that allow long-term intra-amoeba survival of bacteria, thereby also favouring their dissemination (Weekers *et al.*, 1993; Greub and Raoult, 2004; Laskowski-Arce and Orth, 2008). Indeed, many studies have found a role of *Acanthamoeba* spp. as reservoirs and/or vectors of pathogenic bacteria (Barker and Brown, 1994; Winiacka-Krusnell and Linder, 2001; Greub and Raoult, 2002; Vezzulli *et al.*, 2010). Previous reports have indicated the survival and replication of a number of bacteria such as *Salmonella* Typhimurium, *Mycobacterium avium*, *Chlamydia pneumonia*, *Legionella pneumophila*, and *Burkholderia cepacia* within *Acanthamoeba* spp. (Marolda *et al.*, 1999; Molmeret *et al.*, 2005; Casson *et al.*, 2006; Akya *et al.*, 2010; Iskandar and Drancourt, 2010). The mechanisms involved during amoeba – bacteria interactions also vary greatly. Some bacteria escape protozoan ingestion due to their size or the production of toxins and virulence factors (Kinner *et al.*, 1998; Matz *et al.*, 2004; Jezbera *et al.*, 2006; Adiba *et al.*, 2010). Others are ingested but have evolved strategies to not only evade digestion but also multiply within protozoa, the prototypical example being *L. pneumophila* (Molmeret *et al.*, 2005). Therefore, amoebae are believed to promote the survival and growth of many pathogenic bacteria within the environment. In addition, amoebae may be particularly relevant to the transmission of *C. jejuni* to chickens in broiler houses because the persistence of protozoa was recently demonstrated in broiler houses across consecutive rearing cycles (Bare *et al.*, 2011).

Several studies have investigated the survival and replication of *C. jejuni* in co-culture with *A. castellanii* and *Acanthamoeba polyphaga*. It was mentioned that *C. jejuni* cells are able to survive within *A. polyphaga* following co-culture at 37°C in aerobic conditions (Axelsson-Olsson *et al.*, 2005) and that *C. jejuni* internalized within *A. castellanii* could contribute to broilers colonization (Snelling *et al.*, 2008). Although several studies mention intra-amoeba replication, no clear evidence that *C. jejuni* was actually able to multiply inside amoebae was provided (Axelsson-Olsson *et al.*, 2005; 2007; 2010). This probably

reflects the fact that it is difficult to distinguish between actual intracellular replication and saprophytic growth of bacteria in co-cultivation with amoebae, whereby the bacteria may benefit indirectly from environmental conditions created by amoebae. Indeed, other studies have shown that co-culture with *A. castellanii* increased long-term survival of extracellular *C. jejuni* (Bare *et al.*, 2010).

The principal aims of this study were to: (i) investigate the intracellular survival of *C. jejuni* within *A. castellanii* at 25°C in aerobic conditions, (ii) investigate whether *C. jejuni* can survive and replicate inside amoeba cells at 37°C in aerobic conditions, and (iii) find out if *C. jejuni* can benefit from the presence of amoebae to grow extracellularly in aerobic conditions and determine what factors are involved in this saprophytic mode of co-culture. In particular, we focused our attention on the potential correlation between saprophytic growth of *C. jejuni* and consumption of dissolved oxygen by *A. castellanii* in co-culture. These temperatures (25°C and 37°C) were chosen to mimic those of broiler houses and mammalian hosts respectively. At 25°C, *C. jejuni* is not anticipated to be able to replicate at all. At 37°C, *C. jejuni* can not only survive and grow, but it can also express its virulence or invasion genes (Stintzi, 2003) if supported by favourable conditions, such as a microaerophilic environment. As both *Campylobacter* spp. and *A. castellanii* occupy a similar ecological habitat, their interaction likely has significant biological and ecological consequences.

Results

Intracellular killing of C. jejuni by A. castellanii

It was shown earlier that amoebae can phagocytose *C. jejuni* readily (Axelsson-Olsson *et al.*, 2005; Snelling *et al.*, 2005). To determine the fate of intracellular *C. jejuni* after phagocytosis, amoebae were infected for 3 h, washed and treated with gentamicin to kill extracellular bacteria, washed again and incubated for various amounts of time at 25°C in aerobic conditions. This experimental set up allowed pinpointing the kinetics of survival of phagocytosed bacteria. However, as a key technique for studying intracellular survival of bacteria, optimal parameters for the gentamicin assay needed to be established first. Accordingly, we determined that gentamicin (applied at 350 µg ml⁻¹ for 1 h at 25°C in aerobic conditions) killed 100% of *C. jejuni* in amoeba buffer (absence of amoebae) with initial bacterial inoculums between 10⁸ and 10⁹ cfu ml⁻¹. Previous studies have indicated that gentamicin often fails to kill all extracellular bacteria in the presence of epithelial cells (Elsinghorst, 1994). Therefore, we also examined the efficacy of gentamicin killing of extracellular bacteria in the presence of amoebae. The number of recovered bacteria was lower

than 100 cfu ml⁻¹ after gentamicin treatment, indicating that this treatment is suitable to assess intra-amoeba survival of *C. jejuni*. Additional experiments were performed using blue trypan staining to determine whether the gentamicin treatment (at the concentration required for efficient killing of extracellular *C. jejuni*) could have cytotoxic effects towards the amoebae, which may lead to release the intracellular *C. jejuni* and to an underestimation of the number of intracellular *C. jejuni*. There was no significant difference in the number of live *A. castellanii* cells when grown with or without gentamicin treatment (data not shown). We conclude, therefore, that the effect of gentamicin treatment on viability of *A. castellanii* is negligible.

The infection assays were performed using these optimal gentamicin treatment conditions to assess the intracellular survival of *C. jejuni* at 25°C. Immediately after gentamicin treatment (considered as T₀ or 0 h), we observed that 0.21% of the original inoculum was recovered as internalized bacteria (approximately 2.0 × 10⁵ cfu ml⁻¹). Confocal laser scanning microscopy (CLSM) showed that these intracellular *C. jejuni* cells were highly motile (Video S1). However, at 5 and 24 h post gentamicin treatment, only 0.05% and 0.001% of the original inoculum were recovered as internalized bacteria (approximately 4.7 × 10⁴ and 9.0 × 10² cfu ml⁻¹ respectively). The number of intracellular bacteria decreased ~200-fold between 0 and 24 h post gentamicin treatment ($P < 0.01$) (Fig. 1), and there were no cfu detectable 30 h post gentamicin treatment (data not shown). These results suggest that *C. jejuni* rapidly loses viability during the course of its intracellular stage at 25°C. To examine whether the survival and replication of *C. jejuni* observed

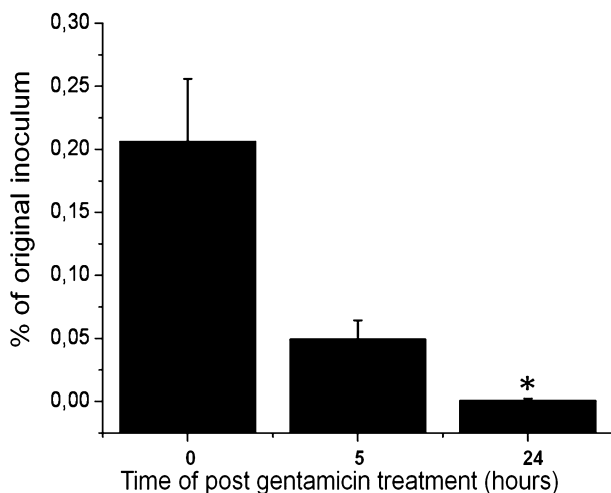

Fig. 1. Survival rates of intracellular *C. jejuni* within *A. castellanii* at 0, 5 and 24 h post gentamicin treatment at 25°C in aerobic conditions. Data are means and standard errors of at least three independent experiments. * $P < 0.01$.

previously in co-cultures at 37°C (Axelsson-Olsson *et al.*, 2005; 2010) were due to the ability of the bacteria to gain entry into the amoeba and multiply intracellularly, the number of intracellular *C. jejuni* was determined by gentamicin protection assays performed at 37°C. No intracellular *C. jejuni* cells were found inside *A. castellanii* at 37°C in aerobic conditions after 24 h (data not shown). This further suggests that *A. castellanii* may support the survival and growth of extra-amoeba *C. jejuni* only.

Intracellular C. jejuni cells are found within acidic vacuoles of A. castellanii

Alongside the viable count assay for the quantification of intracellular bacteria reported above, TEM was used to examine the intracellular localization of *C. jejuni* in *A. castellanii* at 25°C. Sections of *A. castellanii* cells infected with *C. jejuni* obtained immediately after gentamicin treatment showed the bacteria to be confined to tight vacuoles within the host amoebae (Fig. 2A). At 5 h after gentamicin treatment, very few bacterial cells could be seen inside the amoeba vacuoles. Moreover, the percentage of infected amoebae was no more than 10% (Fig. 2B). By 24 h post gentamicin treatment, no bacteria were found inside the amoebae (Fig. 2C). These results indicated that intracellular *C. jejuni* cells remained viable for at least 5 h after gentamicin treatment but eventually were destroyed within host vacuoles. In addition, TEM was also performed to determine whether *C. jejuni* could be found inside *A. castellanii* cells in co-culture at 37°C. However, no internalized *C. jejuni* cells were observed inside amoeba vacuoles after 24 h (data not shown).

A more detailed observation of *C. jejuni* cells internalized within *A. castellanii* at early time points was performed by CLSM. To assess the viability of intracellular *C. jejuni*, the bacteria were treated with CellTracker Red before infection. Live red fluorescent *C. jejuni* cells were observed within vacuoles at 0 and 5 h post gentamicin treatment. Micrographs of labelled *C. jejuni* cells internalized by trophozoites immediately after gentamicin treatment at 25°C are shown in Fig. 3A–D. A decrease in the amount of intracellular *C. jejuni* cells within the trophozoites was observed at 5 h post gentamicin treatment (Fig. 3E–H) and only a few fluorescent *C. jejuni* cells could be seen in a small population of trophozoites at 24 h post gentamicin treatment (Fig. 3I–L). No labelled *C. jejuni* cells were observed inside *A. castellanii* cells at 36 h post gentamicin treatment (data not shown). The simultaneous use of LysoSensor Green DND-189 showed that the vacuoles containing red fluorescent bacteria were acidic. No internalized bacteria could be seen within cyst forms of *A. castellanii* (data not shown). These results correlated directly with the bacteriological data as described above.

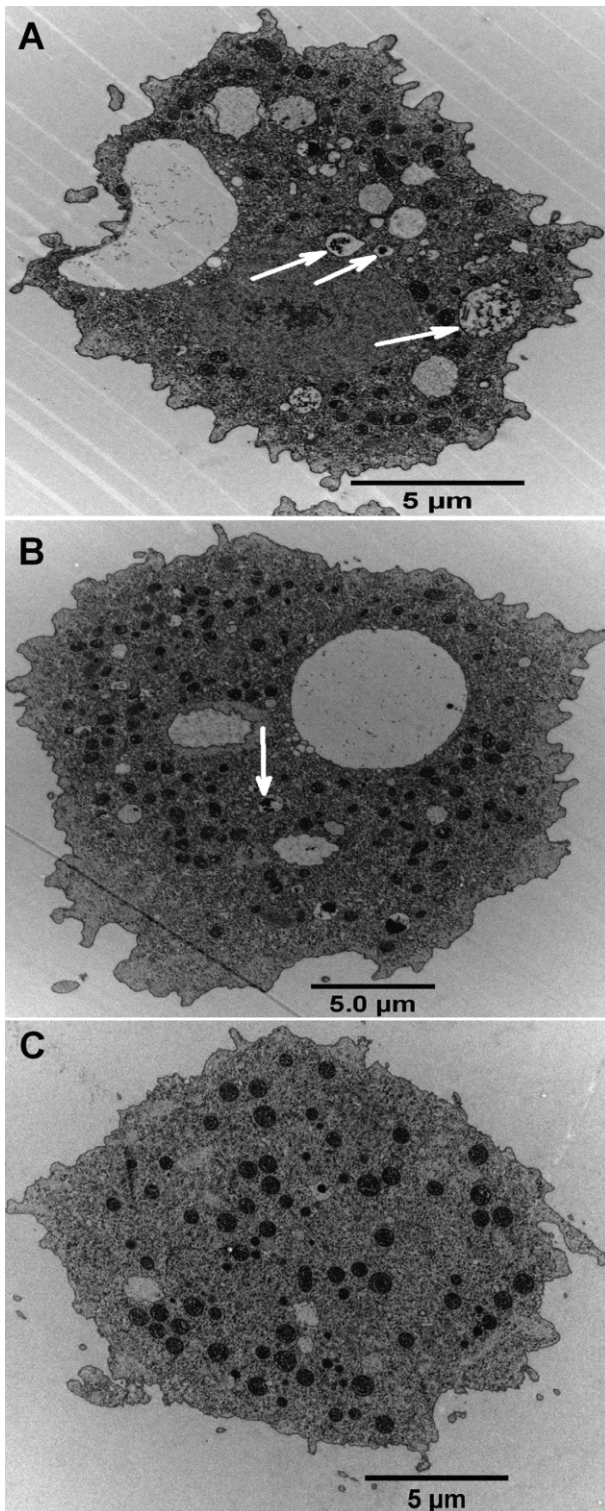

Fig. 2. TEM of *C. jejuni* cells within vacuoles of *A. castellanii* trophozoites at different time points. At 0 h after gentamicin treatment (A), 5 h after gentamicin treatment (B) and 24 h after gentamicin treatment (C). The white arrows (A and B) show *C. jejuni* cells inside amoeba vacuoles. Scale bar = 5 µm.

C. jejuni cells survive and replicate in co-culture medium but not inside *A. castellanii*

We showed that, as expected, *C. jejuni* was unable to survive and replicate in PYG medium in the absence of *A. castellanii* at 37°C in aerobic conditions (Fig. 4, gradient bar). In contrast, when co-cultures of *C. jejuni* and *A. castellanii* were established in PYG medium at 37°C (to mimic the temperature in mammalian cells and also to have a temperature that is permissive for replication of *C. jejuni*) in aerobic conditions, the number of recovered bacteria in the medium increased significantly over time (Fig. 4, white bars). Interestingly, the numbers of *C. jejuni* obtained in these conditions were similar to those obtained in PYG media at 37°C in microaerophilic conditions (Fig. 4, light grey bars). As mentioned above, gentamicin protection assays demonstrated that no intramoeba bacteria were recovered beyond 24 h. Therefore, we conclude that *C. jejuni* survives and replicates in co-culture medium but not inside *A. castellanii*.

Cell contact is not necessary to promote the growth of C. jejuni by A. castellanii in aerobic conditions

To determine whether direct contact between amoebae and *C. jejuni* is necessary for bacterial survival and replication, we examined the ability of *C. jejuni* to grow in PYG medium at 37°C in aerobic conditions while separated from *A. castellanii* in a parachamber. In these experiments, a transwell membrane was used to physically separate the bacteria and *A. castellanii*. For lack of suitable commercial parachamber, a transwell insert with a 0.4 µm pore size membrane was modified with a 0.2 µm pore size membrane. Control experiments were performed to ensure that *C. jejuni* could not cross the modified transwell membrane by seeding the top compartment with *C. jejuni* (at $\sim 1 \times 10^2$ cfu ml⁻¹) and seeding the bottom compartment with amoebae only. Another control experiment was performed by seeding the top chamber with *C. jejuni* (at $\sim 1 \times 10^2$ cfu ml⁻¹) and the bottom chamber with media only and incubated at 37°C in microaerophilic conditions. After 24 and 96 h, 100 µl of media from the top and bottom chambers were withdrawn, spread onto blood agar plates and incubated at 37°C in microaerophilic conditions for 36 h. No *C. jejuni* cells were observed in the bottom chamber media at either time point while $\sim 10^6$ cfu ml⁻¹ and $\sim 10^8$ cfu ml⁻¹ were obtained in the top chamber media after 24 and 96 h respectively.

As shown in Fig. 4 (white bars versus black bars), *C. jejuni* survived and replicated equally well when physically separated from *A. castellanii* as when grown in a co-culture with direct contact with the amoebae. The same final maximal bacterial density ($\sim 9 \log_{10}$ cfu ml⁻¹ at

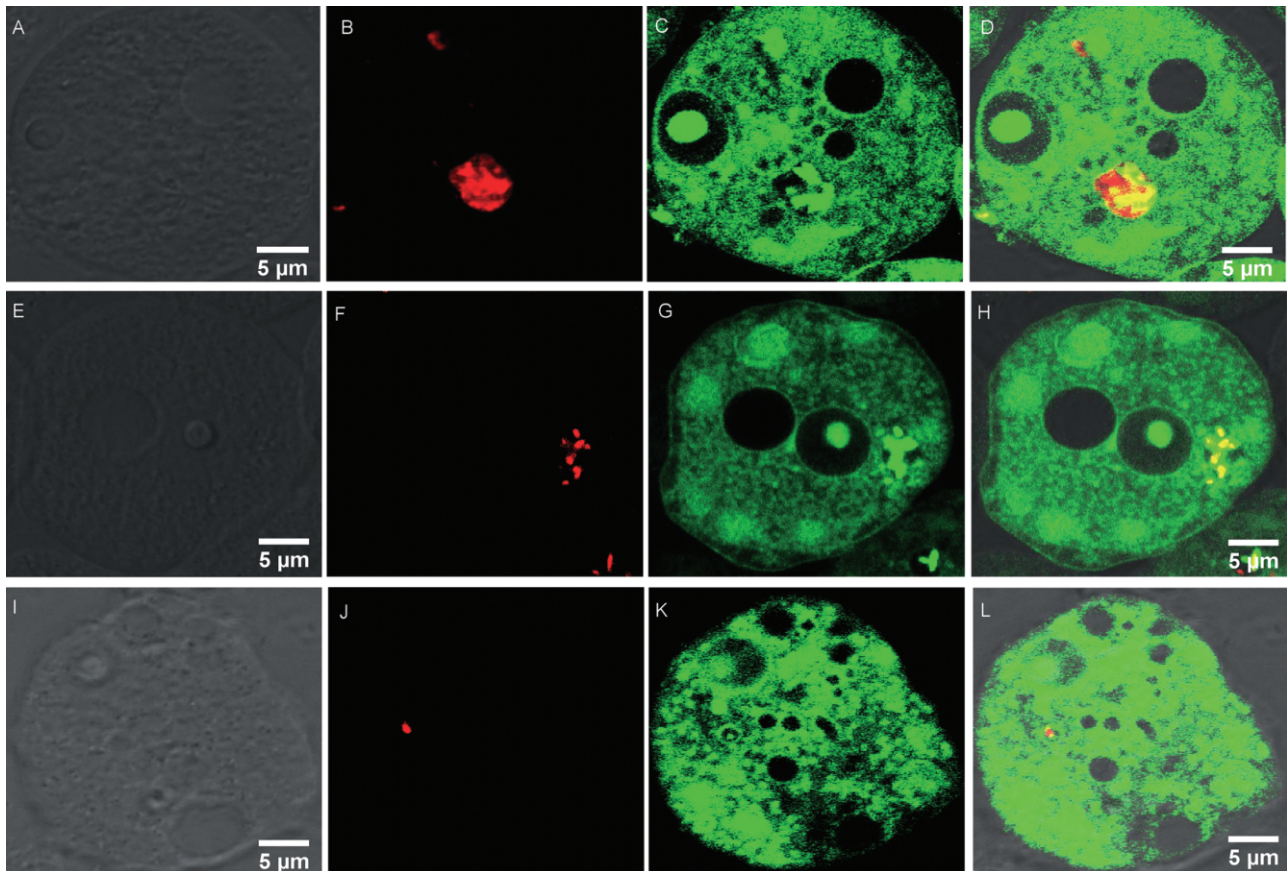

Fig. 3. Confocal microscopy of *C. jejuni* within acidic organelles of *A. castellanii* at time points of *c.* 0 h (A–D), 5 h (E–H), and 24 h (I–L) post gentamicin treatment at 25°C in aerobic conditions. The multiplicity of infection was 100:1 (bacteria : amoeba). (A, E, I) Differential interference contrast image; (B, F, J) *C. jejuni* stained with CellTracker Red; (C, G, K) acidic amoeba organelles coloured with LysoSensor Green; (D, H, L) corresponding overlay. Scale bar = 5 μm.

72 h) and identical kinetics of bacterial growth could be obtained from the two different methods of cultivation (with or without contact with amoebae). The number of *C. jejuni* cells counted decreased slightly by 96 h in both conditions. This could reflect the fact that the cultures had reached their stationary phase, at which stage a fraction of the *C. jejuni* population started turning into the coccoid form, which cannot be cultivated anymore and therefore does not contribute to the viable count data. Thus, our data suggest that *C. jejuni* is able to utilize *A. castellanii* to promote its survival and replication at 37°C under aerobic conditions independently of a direct contact with amoebae.

Preconditioned A. castellanii medium (PAM) does not support aerobic survival and replication of C. jejuni

The results from the parachamber experiments suggested that *A. castellanii* might secrete a factor that would be responsible for the survival and growth of *C. jejuni*. We therefore tested whether PAM from a culture

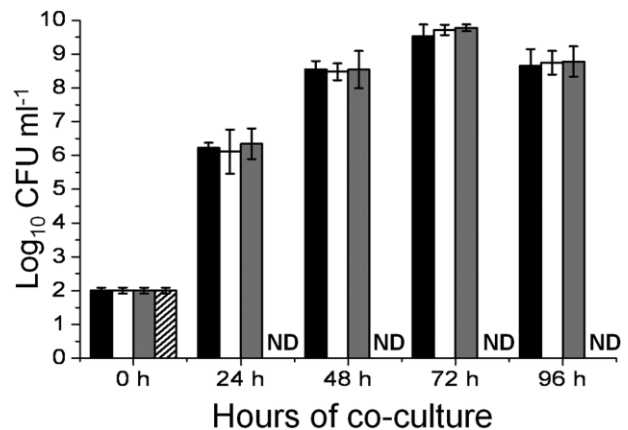

Fig. 4. Growth rates of *C. jejuni* in co-cultivation with amoebae at 37°C in aerobic conditions. While *C. jejuni* cannot survive in PYG medium alone under these conditions (▨), survival of *C. jejuni* is promoted by the presence of *A. castellanii* (□). This effect is observed even when *C. jejuni* cells are separated from amoebae by a 0.2 μm pore size membrane (■). The growth rates of *C. jejuni* in PYG media (absence of amoebae) at 37°C in microaerophilic conditions (■) is presented as a control. Data are means and standard errors of at least three independent experiments; ND, none detected.

of *A. castellanii* alone could recapitulate the same survival effect. We demonstrated that PAM did not support the growth of *C. jejuni* in aerobic conditions (data not shown). Moreover, to examine whether *C. jejuni* cells stimulated *A. castellanii* to secrete a factor to promote their survival, PAM from a co-culture of *A. castellanii* and *C. jejuni* was filtered and used as growth medium for fresh *C. jejuni* cells that were incubated at 37°C in aerobic conditions for 24 or 48 h. However, no bacteria were recovered (data not shown). As a result, we hypothesized that if the aerobic growth of *C. jejuni* at 37°C in co-culture with *A. castellanii* was due to released components from *A. castellanii* that could serve as nutrients for *C. jejuni*, dead amoebae should also support survival of *C. jejuni* in aerobic conditions. Thus, an additional experiment was conducted to examine whether dead *A. castellanii* cells could affect the growth of *C. jejuni* in PYG medium in the same conditions as above. However, no bacteria were recovered after 24 h (data not shown). Altogether, our results indicate that it is unlikely that a factor is secreted or released by *A. castellanii* to promote the growth of *C. jejuni* at 37°C in aerobic conditions.

Reduction of dissolved oxygen level by A. castellanii promotes survival and multiplication of C. jejuni

To understand how *C. jejuni* can survive and multiply under aerobic conditions in co-cultures with or without a direct physical contact with amoebae, we hypothesized that the live amoebae can modify the oxygen level in co-culture medium in a fashion that is beneficial to *C. jejuni*. We therefore tested whether or not *A. castellanii* could reduce the dissolved oxygen in co-culture with *C. jejuni* in aerobic conditions. We measured the dissolved oxygen levels in cultures of *A. castellanii* grown with or without *C. jejuni* in PYG medium. As shown in Fig. 5, the dissolved oxygen level decreased rapidly from approximately 11.6 to 2.5 mg l⁻¹ (reached in ~5 h) in the presence of *A. castellanii*. In contrast, in the absence of amoebae, the oxygen level of PYG medium with or without *C. jejuni* incubated at 37°C in aerobic conditions was constant at ~11–12 mg l⁻¹ (Fig. 5). Likewise, the presence of amoebae resulted in decreased oxygen levels in co-culture experiments, whether the amoebae and bacteria were in direct contact or not. The decrease in oxygen levels occurred within the first 5 h of culture, and the final levels reached were as low as in the absence of bacteria, indicating that *C. jejuni* does not affect the oxygen level. Interestingly, the low dissolved oxygen levels observed in all cultures performed in the presence of *A. castellanii* in aerobic conditions were equal with those observed in the medium of cultures of *C. jejuni* grown in microaerophilic conditions (~2.7 mg l⁻¹). As mentioned above, similar growth rates were observed when *C. jejuni* was grown in

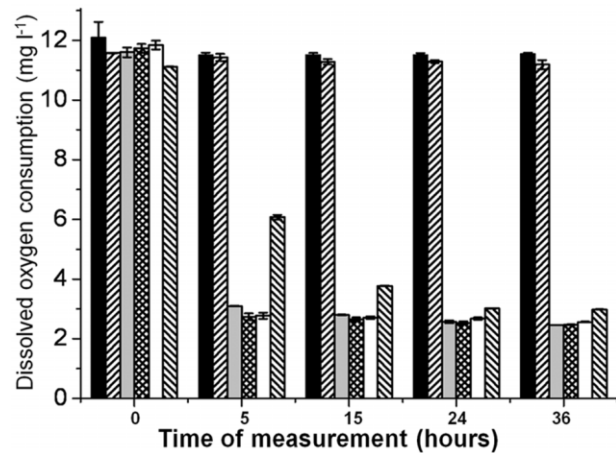

Fig. 5. Measurement of dissolved oxygen levels in aerobic cultures at 37°C at different time points. Comparison of the high levels of dissolved oxygen observed in PYG (■) or PYG inoculated with *C. jejuni* (▨) with the low levels of dissolved oxygen observed in the presence of amoebae (□) indicate consumption of dissolved oxygen by *A. castellanii*. This occurred whether the amoebae were grown with (▩) or without *C. jejuni* (▧), and whether the co-culture occurred with direct bacteria – amoebae contact (▦) or not (▨). The final oxygen levels reached were as low as those observed in *C. jejuni* medium incubated under microaerophilic conditions (▩). Data are means and standard errors of at least three independent experiments.

PYG in microaerophilic conditions and in co-culture with *A. castellanii* in aerobic conditions (Fig. 4, light grey bars). Altogether, these findings suggest that *A. castellanii* cells may reduce the dissolved oxygen leading to the promotion of the survival and replication of *C. jejuni* in co-culture at 37°C under aerobic conditions by creating the microaerophilic environment that is optimal for *C. jejuni*.

Oxygen uptake of Tetrahymena pyriformis promotes the survival of C. jejuni

To examine whether the promotion of *C. jejuni* survival due to oxygen uptake was specific to *A. castellanii*, we performed transwell co-culture experiments using an additional aerobic protozoan: *T. pyriformis*. *Tetrahymena pyriformis* was chosen because, like *A. castellanii*, this bacterivorous protozoan is often present in surface water, it can be grown axenically, and it has been used as a model system for *C. jejuni* infection studies (Snelling *et al.*, 2005). Moreover, *T. pyriformis* has the ability to uptake oxygen in water (Wilson *et al.*, 1979; Slabbert and Morgan, 1982; Gräbsch *et al.*, 2006). Because *T. pyriformis* loses its viability shortly at temperatures above 30°C (Fields *et al.*, 1984), the experiments were performed at 25°C. Under these conditions, *C. jejuni* does not grow, and consequently, only protozoa-mediated enhancement of bacterial survival could be assessed. *Campylobacter jejuni* cells were incubated in PYG media at 25°C in

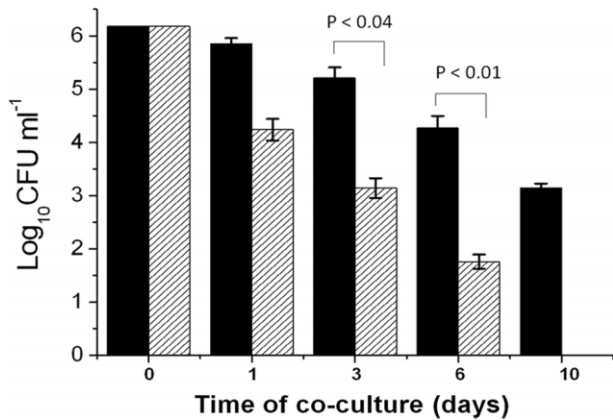

Fig. 6. Survival of *C. jejuni* in parachamber co-cultures with or without *T. pyriformis* at 25°C in aerobic conditions. While *C. jejuni* survives for ~6 days in PYG medium alone under these conditions (▨), survival of *C. jejuni* is promoted by the presence of *T. pyriformis*, despite the physical separation of the bacteria from the protozoa by a 0.2 µm pore size membrane (■). Data are means and standard errors of at least three independent experiments; ND, none detected.

aerobic conditions in the upper chamber of a transwell while the bottom chamber was inoculated with *T. pyriformis* or not. Using this system, the survival of bacterial cells in the presence or absence of *T. pyriformis* was compared after different times over the course of 10 days. The presence of *T. pyriformis* in the bottom chamber enhanced survival of *C. jejuni* at all time points (Fig. 6), indicating that other aerobic organisms than *A. castellanii* can also have the same beneficial effect on the survival of *C. jejuni* in aerobic conditions.

Discussion

The ability of *C. jejuni* to survive in co-culture with *Acanthamoeba* spp. has been reported by several investigations (Axelsson-Olsson *et al.*, 2005; 2010; Snelling *et al.*, 2005; Bare *et al.*, 2010). It has been proposed that intra-amoeba *Campylobacter* can colonize broiler chickens and may represent a significant environmental source of transmission (Snelling *et al.*, 2008). However, it had remained incompletely understood whether or not this bacterium could really survive and replicate intracellularly. By using four different methods, namely gentamicin protection assays, parachamber assays, CLSM and TEM, we showed that the number of *C. jejuni* cells rapidly (within 5 h) decreased within *A. castellanii* and few bacteria remained viable 24 h post gentamicin treatment at 25°C in aerobic conditions, suggesting that intracellular survival and replication do not occur.

Our results seem to conflict with a previous study that concluded on the prolonged intracellular survival of *Campylobacter jejuni* cells within amoebae (Axelsson-Olsson *et al.*, 2005). A first source of discrepancy between

various studies is the bacterial and amoeba strain specificity of the interactions (Bare *et al.*, 2010). We selected *C. jejuni* strain NCTC 11168 for our studies as, being a human clinical isolate from a patient experiencing diarrhoea (Gaynor *et al.*, 2004), it is relevant to human infections. Therefore, it is important to understand the mechanisms by which this strain establishes a reservoir in environmental conditions. In contrast, Axelsson-Olsson and colleagues (2005; 2007) used mostly strain CCUG 11284, and Bare and colleagues (2010) used a wide panel of isolates, which allowed to determine that strains that are poorly invasive have a better survival chance in co-culture with the amoebae than highly invasive strains because they are less prone to intracellular killing.

Another source of discrepancy between studies is the experimental set up. In previous studies, the bacteria and amoebae were co-cultured continuously until the end of the time-course, without interruption of the invasion of the amoebae by the bacteria (Axelsson-Olsson *et al.*, 2005; Snelling *et al.*, 2005; Bare *et al.*, 2010). This did not allow addressing intracellular survival *per se*, as it allowed continuous entry of bacteria in the amoebae. In contrast, in our study, bacterial invasion of amoebae was allowed to occur for 3 h only, after which extracellular bacteria were eliminated by gentamicin treatment and the intracellular survival of *C. jejuni* was assessed at different time points after removal of the extracellular bacteria. This experimental set up allowed precise assessment of intracellular survival. As reported by Axelsson-Olsson and colleagues (2005), we also found motile *C. jejuni* cells inside the amoebae when co-cultured at 25°C (Video S1), but our experimental set up allowed to demonstrate that these were only present at early stages of internalization. Also, in agreement with the study reported by Bare and colleagues (2010), the intra-amoeba bacteria were absent from the cytoplasm. However, contrary to this latter study that reported bacteria both in acidified and non-acidified vacuoles, we only observed intracellular *C. jejuni* in amoeba acidified lysosomes, suggesting that *C. jejuni* does not escape the phago – lysosome fusion. It is likely that the bacteria observed previously in non-acidified vacuoles represented earlier stages of internalization due to the continuous internalization of bacteria. It has been demonstrated that *C. jejuni* survives within intestinal epithelial cells within a compartment that is distinct from lysosomes, whereas in macrophages, *C. jejuni* is delivered to lysosomes and consequently is rapidly killed (Watson and Galán, 2008). In addition, TEM showed the concentration of mitochondria and lysosome-like vesicles at the periphery of vacuoles containing *C. jejuni* cells, suggesting that these structures may play an active role in the degradation of internalized bacteria. These findings are very similar with a previous study that examined the mechanisms of intracellular killing of *C. jejuni* by macroph-

ages (Myszewski and Stern, 1991), and extend the repertoire of bacterial pathogens for which potentially common mechanisms are involved for clearance from infected amoebae and macrophages (Greub and Raoult, 2004).

Intra-amoeba survival of *C. jejuni* has been proposed to provide protection against killing by external agents such as disinfection agents (Snelling *et al.*, 2005; 2008). However, as *C. jejuni* appears unable to escape from phago – lysosome fusion for long periods of time (24 h), as indicated by our data, the contribution of this process to amoeba-mediated transmission of *C. jejuni* to new hosts can be questioned, or at least put in the perspective of the practical context. Most reported protection assays so far involved short-term (1 min) exposure to disinfection agents after co-culture, followed by immediate testing of viability or infectivity of the internalized bacteria (Snelling *et al.*, 2005; 2008). This does not allow harnessing the role of internalization as protection against unfavourable environmental conditions during the chain of transmission to new hosts, where longer exposure both to noxious agent and to intracellular killing mechanisms may be encountered. It would therefore be interesting to determine if the results would be drastically different using internalized *C. jejuni* that resided for longer periods of time (24 h) in the amoebae.

The ability of bacteria to survive in the presence of amoebae has been reported for several other bacteria, such as *Vibrio mimicus* and *Vibrio parahaemolyticus*, *S. Typhimurium*, *B. cepacia*, *L. pneumophila* (Landers *et al.*, 2000; Gaze *et al.*, 2003; Neumeister, 2004; Laskowski-Arce and Orth, 2008; Abd *et al.*, 2010). However, the persistence of these bacteria in the presence of *Acanthamoeba* spp. is likely due to different mechanisms. For example, *M. avium* and *L. pneumophila* could inhibit phagolysosomal vacuole fusion in amoebae and macrophages to avoid intracellular killing (Horwitz, 1984; Frehel *et al.*, 1986; Bozue and Johnson, 1996; Cirillo *et al.*, 1997), which *C. jejuni* is not able to do for long periods of time. Although *C. jejuni* joins the ranks of other bacteria that can benefit from the co-culture mode of growth with amoeba, the mechanisms involved appear different. We turned our attention on examining the growth-promoting effects of amoebae on the extracellular *C. jejuni* population, which we surmised would also play an important role for transmission of *C. jejuni* from the environment to new hosts. These experiments were therefore conducted at 37°C to support the growth of *C. jejuni*, unless indicated otherwise.

Interestingly, in co-culture with *A. castellanii* at 37°C in aerobic conditions, we observed a huge number of recovered bacteria after 24 h. Our results are consistent with what has been reported by Axelsson-Olsson and colleagues (2005; 2010), who showed that not only *A. cas-*

tellanii can promote the survival and growth of *C. jejuni* but also indicated that other amoebae could enhance the multiplication of *Campylobacters* including *C. jejuni*, *C. coli* and *C. lari* in the same conditions. Altogether, these findings are significant as a diverse array of protozoa has been observed to persist in broiler houses (Bare *et al.*, 2011). In addition, our results from the parachamber study showed that the ability of *A. castellanii* to promote the survival and multiplication of *C. jejuni* does not require a direct contact between the amoebae and bacteria, suggesting that this bacterium can survive and replicate in co-culture media, but not inside the amoebae. This conclusion is supported by examination by CLSM and TEM, and by gentamicin protection assays of infected amoebae at different stages of co-culture. In fact, we were unable to observe any internalized bacteria within the amoebae past 24 h. Nevertheless, we found that *C. jejuni* survived equally well when directly co-cultured with *A. castellanii* or when physically separated from the amoebae by a membrane. Thus, survival and replication of *C. jejuni* could have been mediated by a diffusible factor produced by the amoebae as reported previously in the case of *B. cepacia* and *V. parahaemolyticus* (Marolda *et al.*, 1999; Laskowski-Arce and Orth, 2008). We showed that this was not the case because *C. jejuni* cells were unable to survive or multiply in preconditioned amoeba medium (PAM) in aerobic conditions after 24 h, suggesting that PAM does not support the survival and replication of this bacterium. Similarly, no bacteria were recovered when *C. jejuni* was cultured with dead *A. castellanii* cells after 24 h. This finding is in agreement with the study reported by Bare and colleagues (2010) in which they demonstrate that amoeba cell debris do not support the survival of *C. jejuni*. Taken together, these results indicated that the bacteria may require the continuous support of live *A. castellanii* cells, or that the diffusible factor, if any, may be rapidly metabolized.

Because *C. jejuni* cells are eventually degraded intracellularly within *A. castellanii* at 25°C but can survive and replicate extracellularly in co-culture medium at 37°C in aerobic conditions, we hypothesized that *A. castellanii* may produce the microaerophilic conditions necessary to support the growth of *C. jejuni*. In support of this hypothesis, we observed that the levels of dissolved oxygen in aerobic cultures of *A. castellanii* were much lower than those of PYG media with or without *C. jejuni*. We also observed that there was no significant difference between the dissolved oxygen levels of co-culture medium (without a membrane), parachamber medium (with a membrane) and microaerophilic culture medium (no amoebae). These findings suggested that *C. jejuni* may benefit from microaerophilic conditions created by *A. castellanii* despite the fact that *C. jejuni* is well equipped with an oxidative stress response system

(Palyada *et al.*, 2009). These results are in agreement with those reported by Watson and Galán (2008) who revealed that *C. jejuni* could benefit from the low-oxygen environment in epithelial cells to survive and replicate. Likewise, Hilbert and colleagues (2010) reported that *C. jejuni* can survive under conditions of atmospheric oxygen tension with the support of *Pseudomonas* spp. Interestingly, our data also showed no significant difference of dissolved oxygen levels of the culture medium of amoebae alone and those of co-culture media of amoebae and *C. jejuni*. This indicates that the amoebae uptake the dissolved oxygen themselves, and do not need *C. jejuni* to stimulate their consumption.

In order to examine whether the depletion of oxygen is specific to *A. castellanii*, we performed a co-culture survival experiment using *T. pyriformis*, which is able to uptake oxygen in water (Wilson *et al.*, 1979; Slabbert and Morgan, 1982; Gräbsch *et al.*, 2006). Our data indicate that *T. pyriformis* could also prolong the survival of *C. jejuni* without direct contact. This finding is in agreement with a previous study reported by Snelling and colleagues (2005). Altogether, our results provide clear evidence that *C. jejuni* benefits from the low-oxygen environment created by amoebae when grown in co-cultures with live *A. castellanii* cells.

Overall, we can reconcile all our findings on the interactions between *C. jejuni* and amoebae with previous studies that suggest a role for such interactions in the transmission of *C. jejuni* to new hosts, especially relevant to transmission to chicks in broiler houses. In a fairly comprehensive study, *C. jejuni* contamination was found to occur for at least one rearing period in all farms investigated, and the persistence of a variety of free-living protozoa including amoebae was frequently observed (Bare *et al.*, 2011). Also, our experiments take into account the temperature in broiler houses, which ranges from 37°C (first week of rearing cycle) to 25°C (end of cycle) (Bare *et al.*, 2010), and differentially affects the impact of the bacteria – amoeba interactions. It has been reported that chicks could be experimentally colonized by intra-amoeba *C. jejuni* (Snelling *et al.*, 2008), chick colonization was obtained with approximately 1.7×10^4 cfu ml⁻¹ of internalized *C. jejuni*, and, as mentioned above, these bacteria were likely freshly internalized since the amoebae were used immediately after removal of extracellular bacteria. Our time-course studies of survival of internalized *C. jejuni* at 25°C also suggest an opportunity for *C. jejuni* to be transferred from the amoebae to a new host. However, the window of opportunity is rather narrow as only approximately 0.05% (approximately 4.7×10^4 cfu ml⁻¹) of the original inoculum was recovered at 5 h post gentamicin treatment and only 0.001% (approximately 9.0×10^2 cfu ml⁻¹) of the original inoculum was recovered after 24 h. This low concentra-

tion of intracellular *C. jejuni* cells may not be enough to colonize the chicks. Overall, although short-term, the survival of *C. jejuni* inside the amoebae may nevertheless contribute to contamination of chicks as it can enhance survival during water chlorination or during passage through the host's gastric environment. Prompt release of the bacterium from the amoebae would need to occur in the host intestine so as to prevent its destruction by the amoebae. Also, although the proportion of live intra-amoebae bacteria reaching a new host may be fairly low based on all the considerations mentioned above, it is nevertheless possible that the intra-amoebae passage could enhance the virulence of *C. jejuni* by allowing better pre-adaptation to the host, as suggested by previous studies (Cirillo *et al.*, 1997; Greub and Raoult, 2004).

Although our results indicate that *C. jejuni* does not survive within the amoebae for a long time at 25°C, a small number of bacteria is still protected by amoebae from the disinfectant killing for at least 5 h (as shown by our gentamicin protection assay). During this period, chicks may still get contaminated by *Campylobacter* from infected amoebae present in the water source. Based on all considerations described above, intra-amoeba transport of *C. jejuni* appears unlikely to be the sole aspect of the amoeba – bacteria interaction involved in broiler contamination between rearing cycles, but will play an important role if the drinking water source/system used allows continuous replenishment of the amoebae with live *C. jejuni*. The development of biofilms containing both bacteria and amoebae in water distribution systems of broiler houses probably provides means for continuous contamination of the water (and downstream of the chicks) by release of infected amoebae from biofilms. *Campylobacter jejuni* has been shown to colonize biofilms from poultry environment, often as part of mixed-microbial populations (Hanning *et al.*, 2008; Teh *et al.*, 2010) and incorporation of *C. jejuni* in biofilms is regulated by the oxygen level (Reuter *et al.*, 2010). Biofilms may provide a means of escaping exposure to high-oxygen levels. Amoebae may be secondary colonizers of such biofilms, further maintaining a lower oxygen level while promoting the growth of the bacterial population. In this context, a fraction of the bacterial population would serve as simple food source for the amoebae while the rest of the population, being extracellular, could benefit from the lower oxygen tension generated locally by the amoebae and grow actively. In effect, this would allow preservation of the amoebae's food source while also resulting in continuous contamination of the flowing water. It will therefore be interesting to study the potential of *C. jejuni* for biofilm formation or further growth within biofilms in the presence of various amoebae under continuous flow.

In summary, by using several different techniques in this study, we demonstrated that *C. jejuni* does not survive ingestion by *A. castellanii* at 25°C in aerobic conditions. We also showed that *C. jejuni* cells can survive and replicate well in aerobic co-culture with the amoebae at 37°C but not inside *A. castellanii*. Although it is possible that the survival and growth of *C. jejuni* in co-culture may be mediated by a factor continuously secreted by *A. castellanii*, our studies identified the depletion of dissolved oxygen by *A. castellanii* as a major contributor for this phenomenon.

Experimental procedures

Microorganisms and culture conditions

The reference strain *C. jejuni* ATCC 700819 [National Collection of Type Cultures (NCTC) 11168] obtained from the American Type Culture Collection was used in all experiments. Before each experiment, bacteria were typically grown under microaerophilic conditions for 24 h on conventional blood agar plates [Tryptic soy agar containing 5% (v/v) whole sheep blood, 10 µg ml⁻¹ vancomycin and 5 µg ml⁻¹ trimethoprim] at 37°C. For infection assays, bacterial cells were harvested and diluted in amoeba buffer or peptone – yeast extract – glucose medium [PYG; 2% proteose peptone, 0.1% yeast extract, 4 mM MgSO₄·7H₂O, 0.4 mM CaCl₂, 0.05 mM Fe(NH₄)₂(SO₄)₂·6H₂O, 2.5 mM Na₂HPO₄·7H₂O, 2.5 mM KH₂PO₄, 0.1% sodium citrate dihydrate, and 0.1 M glucose, pH 6.5]. Amoeba buffer was a non-nutrient culture media for *A. castellanii* including 4 mM MgSO₄·7H₂O, 0.4 mM CaCl₂, 0.05 mM Fe(NH₄)₂(SO₄)₂·6H₂O, 2.5 mM Na₂HPO₄·7H₂O, 2.5 mM KH₂PO₄ but excluding peptone, yeast extract and glucose.

Amoeba reference strain *A. castellanii* ATCC 30234 and protozoan reference strain *T. pyriformis* ATCC 3005 were obtained from the American Type Culture Collection. The protozoa were maintained in PYG medium in 75 cm² tissue culture flasks (BD, Mississauga, ON, Canada) at 25°C without aeration. *Acanthamoeba castellanii* and *T. pyriformis* were routinely subcultured every 5 and 7 days respectively.

Amoeba infection assays and determination of intracellular survival of bacteria

Co-cultures of *C. jejuni* with monolayers of amoeba cells were performed in 6-well tissue plates (BD, Mississauga, ON, Canada). Logarithmic *A. castellanii* cultures in 75 cm² tissue culture flasks were washed twice with phosphate buffered saline (PBS) and resuspended in 25 ml of amoeba buffer by tapping the flask. Using this buffer, amoebae can survive but do not multiply and will phagocytose the bacteria due to starvation. Amoebae were enumerated using a Burker-Turk (Nitrin, Tokyo, Japan), diluted and seeded at a density of 2 × 10⁵ amoeba cells per ml in amoeba buffer in 6-well plates and incubated for 2 h to allow the trophozoites to settle and form a monolayer. Bacterial cells were harvested, washed and adjusted to an OD₆₀₀ of 0.8. Washed bacterial cells were added to achieve a multiplicity of infection (moi) of ~100 bacterial cells per amoeba and the actual moi was also cal-

culated by enumerating bacteria on blood agar Petri-dishes. The 6-well plates were then centrifuged (1000 r.p.m., 3 min) to sediment the bacterial cells onto the surface of the trophozoites. Bacterial invasion was permitted to continue for 3 h at 25°C in aerobic conditions. This temperature is an optimal temperature for amoebae and mimics the same environmental condition in the broiler house. The wells then were washed three times with 2 ml of amoeba buffer to remove extracellular bacteria, followed by the addition of 2 ml of fresh amoeba buffer containing 350 µg ml⁻¹ gentamicin (BioBasics) and incubated at 25°C for 1 h to kill remaining extra-amoeba bacteria. One hundred microlitres of 10⁷ cfu ml⁻¹ of heat-killed *Escherichia coli* DH5α cells (at 90°C for 20 min) were added to each well as a food source to avoid stress by starvation of amoebae. The infected amoeba monolayers were processed at 0, 5 and 24 h after gentamicin treatment. Processing at each time point was as follows. The buffer was carefully aspirated and the wells were washed three times with 2 ml of amoeba buffer to remove the antibiotic. Then, the number of amoebae in the wells was counted directly using an inverted light microscope. A 100 µl of aliquots of the last wash step were sampled to determine the number of remaining extracellular bacteria after gentamicin treatment. Five hundred microlitres of sterile PBS containing 95% Triton X-100 [final concentration 0.3% (v/v) in PBS] were added to lyse infected amoebae. The extent of lysate was monitored for 10–15 min under the inverted light microscope until approximately 100% of the trophozoites were lysed. A 100 µl of aliquots of 10-fold serial dilutions of the lysate was taken for bacterial counts to determine the number of intracellular bacteria. Wells to be processed at a later time were washed with amoeba buffer, and heat-killed *E. coli* cells were added as indicated above. Additional experiments were performed using blue trypan staining to determine the effect of gentamicin treatment on the viability of amoebae. *Acanthamoeba castellanii* cells were seeded into 6-well plates, incubated at 25°C for 2 h and then treated with or without gentamicin for 1 h. All experiments were carried out in triplicate.

Transwell system and co-cultures with A. castellanii

Co-cultivation was established as described above with the following modifications. Logarithmic *A. castellanii* cultures in 75 cm² tissue culture flasks were washed twice with amoeba buffer. The monolayer was resuspended in fresh PYG media by tapping the flask and the number of amoebae was counted using a Burker-Turk. A transwell insert of 12-well plates (Costar, Washington, USA) with a 0.4 µm pore size membrane was modified with a 0.2 µm pore size permeable polycarbonate membrane (GE Osmonics Labstore, Minnetonka, MN, USA) by overlaying the existing membrane with the 0.2 µm pore size membrane. The modified transwell membrane was inserted into each well of the 12-well tissue culture plate. A total of 600 µl of 4 × 10² bacteria per ml in PYG media was added to the top of each chamber (1.2 × 10² total bacteria per ml in 2 ml of a final volume). The experiments were conducted by sampling the media at the bottom of each chamber to confirm that no *C. jejuni* could pass through the membrane. Amoebae were diluted in PYG media to a density of approximately 10⁶ amoebae per ml and 1.4 ml of this suspension was added to the bottom chamber (7 × 10⁵

amoebae per ml in 2 ml of a final volume). As control experiments, cultures were set up containing *A. castellanii* alone (bottom), *C. jejuni* alone (top), or *A. castellanii* and *C. jejuni* together in the bottom chamber without a membrane. All parachamber cultures were incubated at 37°C in aerobic conditions.

Transwell system and co-cultures with *T. pyriformis*

A total of 600 µl of 5×10^6 bacteria per ml in PYG media was added to the top of each chamber (1.5×10^6 total bacteria per ml in a final volume of 2 ml). Logarithmic *T. pyriformis* cultures in 75 cm² tissue culture flasks were counted using a Burkert-Turk. *Tetrahymena pyriformis* cells were diluted in PYG media to a density of approximately 1×10^6 cells per ml and 1.4 ml of this suspension was added to the bottom chamber (7×10^5 protozoan cells per ml in a final volume of 2 ml). As a control experiment, cultures were set up with *C. jejuni* seeding on the top chamber and PYG media without protozoa in the bottom chamber. The parachamber cultures were incubated at 25°C in aerobic conditions. This temperature was chosen because *T. pyriformis* does not survive well at higher temperatures (Fields *et al.*, 1984). Aliquots of 100 µl of co-culture media were withdrawn at different time points to determine the number of live bacteria by cfu counting.

Preconditioned *A. castellanii* medium (PAM)

To examine whether *A. castellanii* secretes a factor to promote the survival and replication of *C. jejuni* in co-culture at 37°C in aerobic conditions, preconditioned *A. castellanii* medium (PAM) was generated by collecting the medium from the cultures of *A. castellanii* alone or grown in co-culture with *C. jejuni* for 1, 2, 3 and 4 days. The medium was filtered using 0.22 µm pore-size syringe filters and used to grow *C. jejuni* at 37°C in aerobic conditions. *Campylobacter jejuni* was added into each PAM (final concentration 1.2×10^2 cfu ml⁻¹) and incubated at 37°C in aerobic conditions for 48 h. To examine whether dead amoebae could support survival of *C. jejuni*, *A. castellanii* cells grown in PYG medium were heat-killed at 90°C for 20 min (Borazjani *et al.*, 2000), then *C. jejuni* cells (final concentration 1.2×10^2 cfu ml⁻¹) were added and incubated at 37°C in aerobic conditions for 48 h. After 24 and 48 h of inoculation, one hundred microlitres of aliquots of PAM were spread on blood agar plates and incubated at 37°C in microaerophilic conditions for 36 h to count recovered bacteria.

Dissolved oxygen consumption by *A. castellanii*

Dissolved oxygen measurements were conducted in a fully enclosed, water-jacketed Clark-type electrode (model OX1LP; Qubit Systems, Kingston, Ontario, Canada) operated at 37°C. Measurements were performed on 1 ml of cultured medium of either *A. castellanii* alone (10^6 amoebae per ml), *C. jejuni* alone (10^6 cfu ml⁻¹), or a co-culture of *A. castellanii* (final concentration 7×10^5 amoebae per ml) and *C. jejuni* (final concentration 1.2×10^2 cfu ml⁻¹) together at 37°C in aerobic conditions at various time points. A 25 mM potassium phosphate buffer pH 7.4 was used to optimize

sensitivity and accuracy in electron node. The depletion of dissolved oxygen was recorded using Logger Pro 3.2 (Vernier Software and Technology, Beaverton, OR). The media from co-cultures in parachamber as described above were also collected to measure the oxygen consumption at various time points. As control experiments, the measurements were performed for PYG media with or without *C. jejuni* (10^6 cfu ml⁻¹) incubated at 37°C in aerobic conditions. Additional experiments were also conducted to examine whether the dissolved oxygen level in PYG culture with *C. jejuni* alone at 37°C in microaerophilic conditions was the same as with a co-culture of *A. castellanii* and *C. jejuni* at 37°C in aerobic conditions. To do so, *C. jejuni* was inoculated in PYG media at concentration 1.2×10^2 cfu ml⁻¹ in a 25 cm² tissue culture flask (BD, Mississauga, ON, Canada) and the flask was then placed in the microaerophilic incubator at 37°C.

CLSM

To visualize intracellular bacteria, amoebae were co-cultured with *C. jejuni* in 6-well tissue culture plates as described previously, except that the amoebae were overlaid on sterile 22 mm diameter round glass coverslips (VWR, USA). Before infection, *C. jejuni* cells were incubated at 37°C in amoeba buffer in microaerophilic conditions for 45 min with a final concentration of 10 µg ml⁻¹ of Celltracker Red CMTPX (Invitrogen, Burlington, ON, Canada) according to the manufacturer's recommendations. For labelling of acidic vacuoles, infected *A. castellanii* monolayers were stained with 10 µM LysoSensor Green DND-189 (Invitrogen, Burlington, ON, Canada) for 30 min before each time point according to the manufacturer's recommendations. All assays were carried out in the dark to avoid photobleaching of labelled cells. Cells were dried on poly-L-lysine slides before visualization under a confocal laser scanning microscope (Zeiss Axiovert 200 M, Carl Zeiss vision, Germany). Motile *C. jejuni* cells within the amoebae immediately after gentamicin treatment were tracked using time-lapse confocal laser-scanning microscope (Zeiss LSM-510 system with inverted Axiovert 200 M microscope), equipped with argon and helium-neon lasers, under 63× objective. Three frames were taken every second and the size of the movie frame corresponds to 512 × 512 µm. Confocal microscopy was done at the gap junction facility of the University of Western Ontario, Canada.

Transmission electron microscopy (TEM)

The localization of *C. jejuni* inside *A. castellanii* was analysed by TEM. Infected amoebae were washed three times with amoeba buffer to remove the extracellular bacteria and incubated in fresh amoeba buffer containing gentamicin with a final concentration 350 µg ml⁻¹ for 1 h. The monolayers were washed three times with 1× PBS pH 7.4 and resuspended in antibiotic-free amoeba buffer. The infected amoeba cells were centrifuged for 10 min at 300 g. Each pellet of infected amoebae was fixed in 2.5% glutaraldehyde in 0.1 M sodium cacodylate buffer pH 7.3, with 0.1 M sucrose and 3 mM CaCl₂, for 30 min at room temperature. Samples were then washed in sodium cacodylate buffer and post-fixed in 2%

osmium tetroxide in the same buffer for 1 h. The samples were centrifuged into pellets, dehydrated according to standard procedures and embedded in Epon. Ultrathin sections were collected on one-hole copper grids, and stained with uranyl acetate and lead citrate. Sections were examined with a Philips CM 100 TEM operated at 80 kV accelerating tension. Images were recorded with an OSIS Veleta 2k × 2k CCD camera and the Analysis ITEM software package. TEM was done at the Core Facility for Integrated Microscopy (CFIM) at University of Copenhagen, Denmark.

Statistical analysis

A Student's *t*-test was used to compare the numbers of *C. jejuni* within *A. castellanii* as well as in co-culture. *P*-values of < 0.05 were considered statistically significant.

Acknowledgements

This study was supported in part by the Pathos Project funded by the Strategic Research Council of Denmark (ENV 2104–07-0015) and Otto Mønsted Foundation, and in part by the Natural Sciences and Engineering Research Council of Canada (RGPIN 240762–2010 to Dr. Creuzenet). We thank Dr. Gregory Penner for lending us his oxygen sensing device and Ximena Vedoya for operating instructions. We thank Dr. Valvano for the use of the tissue culture facility and microscopes, and Dr. Koval for the use of her microscope. We also thank R. Ford for critical reading of this manuscript.

References

- Abd, H., Valeru, S.P., Sami, S.M., Saeed, A., Raychaudhuri, S., and Sandström, G. (2010) Interaction between *Vibrio mimicus* and *Acanthamoeba castellanii*. *Environ Microbiol Rep* **2**: 166–171.
- Adiba, S., Nizak, C., van Baalen, M., Denamur, E., and Depaulis, F. (2010) From grazing resistance to pathogenesis: the coincidental evolution of virulence factors. *PLoS ONE* **5**: e11882.
- Akya, A., Pointon, A., and Thomas, C. (2010) *Listeria monocytogenes* does not survive ingestion by *Acanthamoeba polyphaga*. *Microbiology* **156**: 809–818.
- Allos, B.M., and Blaser, M.J. (1995) *Campylobacter jejuni* and the expanding spectrum of related infections. *Clin Infect Dis* **20**: 1092–1101.
- Ang, C.W., van Doorn, P.A., Endtz, H.P., Merkies, I.S.J., Jacobs, B.C., de Klerk, M.A., et al. (2000) A case of Guillain-Barré syndrome following a family outbreak of *Campylobacter jejuni* enteritis. *J Neuroimmunol* **111**: 229–233.
- Axelsson-Olsson, D., Waldenstrom, J., Broman, T., Olsen, B., and Holmberg, M. (2005) Protozoan *Acanthamoeba polyphaga* as a potential reservoir for *Campylobacter jejuni*. *Appl Environ Microbiol* **71**: 987–992.
- Axelsson-Olsson, D., Ellstrom, P., Waldenstrom, J., Haemig, P.D., Brudin, L., and Olsen, B. (2007) *Acanthamoeba-Campylobacter* coculture as a novel method for enrichment of *Campylobacter* species. *Appl Environ Microbiol* **73**: 6864–6869.
- Axelsson-Olsson, D., Olofsson, J., Svensson, L., Griekspoor, P., Waldenström, J., Ellström, P., and Olsen, B. (2010) Amoebae and algae can prolong the survival of *Campylobacter* species in co-culture. *Exp Parasitol* **126**: 59–64.
- Bare, J., Sabbe, K., Huws, S., Vercauteren, D., Braeckmans, K., Van Gremberghe, I., et al. (2010) Influence of temperature, oxygen and bacterial strain identity on the association of *Campylobacter jejuni* with *Acanthamoeba castellanii*. *FEMS Microbiol Ecol* **74**: 371–381.
- Bare, J., Houf, K., Verstraete, T., Vaerewijck, M., and Sabbe, K. (2011) Persistence of free-living protozoan communities across rearing cycles in commercial poultry houses. *Appl Environ Microbiol* **77**: 1763–1769.
- Barker, J., and Brown, M.R.W. (1994) Trojan horses of the microbial world: protozoa and the survival of bacterial pathogens in the environment. *Microbiology* **140**: 1253–1259.
- Borazjani, R.N., May, L.L., Noble, J.A., Avery, S.V., and Ahearn, D.G. (2000) Flow cytometry for determination of the efficacy of contact lens disinfecting solutions against *Acanthamoeba* spp. *Appl Environ Microbiol* **66**: 1057–1061.
- Bozue, J., and Johnson, W. (1996) Interaction of *Legionella pneumophila* with *Acanthamoeba castellanii*: uptake by coiling phagocytosis and inhibition of phagosome-lysosome fusion. *Infect Immun* **64**: 668–673.
- Casson, N., Medico, N., Bille, J., and Greub, G. (2006) *Parachlamydia acanthamoebae* enters and multiplies within pneumocytes and lung fibroblasts. *Microbes Infect* **8**: 1294–1300.
- Cirillo, J., Falkow, S., Tompkins, L., and Bermudez, L. (1997) Interaction of *Mycobacterium avium* with environmental amoebae enhances virulence. *Infect Immun* **65**: 3759–3767.
- Coker, A.O., Isokpehi, R.D., Thomas, B.N., Amisu, K.O., and Obi, C.L. (2002) Human campylobacteriosis in developing countries. *Emerg Infect Dis* **8**: 237–243.
- Elsinghorst, E.A. (1994) Measurement of invasion by gentamicin resistance. *Methods Enzymol* **236**: 405–420.
- Fields, B.S., and Shotts, E.B. Jr, Feeley, J.C., Gorman, G.W., and Martin, W.T. (1984) Proliferation of *Legionella pneumophila* as an intracellular parasite of the ciliated protozoan *Tetrahymena pyriformis*. *Appl Environ Microbiol* **47**: 467–471.
- Frehel, C., de Chastellier, C., Lang, T., and Rastogi, N. (1986) Evidence for inhibition of fusion of lysosomal and prelysosomal compartments with phagosomes in macrophages infected with pathogenic *Mycobacterium avium*. *Infect Immun* **52**: 252–262.
- Friedman, C., Neimann, J., Wegener, H., and Tauxe, R. (2000) Epidemiology of *Campylobacter jejuni* infections in the United States and other industrialised nations. In *Campylobacter*, 2nd edn. Nachamkin, I., and Blaser, M.J. (eds). Washington, DC, USA: American Society for Microbiology Press, pp. 121–138.
- Gaynor, E.C., Cawthraw, S., Manning, G., MacKichan, J.K., Falkow, S., and Newell, D.G. (2004) The genome-sequenced variant of *Campylobacter jejuni* NCTC 11168 and the original clonal clinical isolate differ markedly in colonization, gene expression, and virulence-associated phenotypes. *J Bacteriol* **186**: 503–517.

- Gaze, W.H., Burroughs, N., Gallagher, M.P., and Wellington, E.M.H. (2003) Interactions between *Salmonella* typhimurium and *Acanthamoeba polyphaga* and observation of a new mode of intracellular growth within contractile vacuoles. *Microb Ecol* **46**: 358–369.
- Gormley, F.J., MacRae, M., Forbes, K.J., Ogden, I.D., Dallas, J.F., and Strachan, N.J.C. (2008) Has retail chicken played a role in the decline of human campylobacteriosis? *Appl Environ Microbiol* **74**: 383–390.
- Gräbsch, C., Wichmann, G., Loffhagen, N., Herbarth, O., and Müller, A. (2006) Cytotoxicity assessment of gliotoxin and penicillic acid in *Tetrahymena pyriformis*. *Environ Toxicol* **21**: 111–117.
- Greub, G., and Raoult, D. (2002) Crescent bodies of *Parachlamydia acanthamoeba* and its life cycle within *Acanthamoeba polyphaga*: an electron micrograph study. *Appl Environ Microbiol* **68**: 3076–3084.
- Greub, G., and Raoult, D. (2004) Microorganisms resistant to free-living amoebae. *Clin Microbiol Rev* **17**: 413–433.
- Hanning, I., Jarquin, R., and Slavik, M. (2008) *Campylobacter jejuni* as a secondary colonizer of poultry biofilms. *J Appl Microbiol* **105**: 1199–1208.
- Havelaar, A.H., van Pelt, W., Ang, C.W., Wagenaar, J.A., van Putten, J.P.M., Gross, U., and Newell, D.G. (2009) Immunity to *Campylobacter*: its role in risk assessment and epidemiology. *Crit Rev Microbiol* **35**: 1–22.
- Hilbert, F., Scherwitzel, M., Paulsen, P., and Szostak, M.P. (2010) Survival of *Campylobacter jejuni* under conditions of atmospheric oxygen tension with the support of *Pseudomonas* spp. *Appl Environ Microbiol* **76**: 5911–5917.
- Horwitz, M.A. (1984) Phagocytosis of the Legionnaires' disease bacterium (*Legionella pneumophila*) occurs by a novel mechanism: engulfment within a *Pseudopod* coil. *Cell* **36**: 27–33.
- Humphrey, T.J. (1992) *Campylobacter jejuni*: some aspects of epidemiology, detection and control. *Br Food J* **94**: 21–25.
- Inglis, G.D., Kalischuk, L.D., and Busz, H.W. (2004) Chronic shedding of *Campylobacter* species in beef cattle. *J Appl Microbiol* **97**: 410–420.
- Inglis, G.D., Kalischuk, L.D., Busz, H.W., and Kastelic, J.P. (2005) Colonization of cattle intestines by *Campylobacter jejuni* and *Campylobacter lanienae*. *Appl Environ Microbiol* **71**: 5145–5153.
- Inglis, G.D., Morck, D.W., McAllister, T.A., Entz, T., Olson, M.E., Yanke, L.J., and Read, R.R. (2006) Temporal prevalence of antimicrobial resistance in *Campylobacter* spp. from beef cattle in Alberta feedlots. *Appl Environ Microbiol* **72**: 4088–4095.
- Iskandar, B.S., and Drancourt, M. (2010) Surviving within the amoeba exocyst: the *Mycobacterium avium* complex paradigm. *BMC Microbiol* **10**: 99.
- Jezbera, J., Hornák, K., and Šimek, K. (2006) Prey selectivity of bacterivorous protists in different size fractions of reservoir water amended with nutrients. *Environ Microbiol* **8**: 1330–1339.
- Jones, D.M., Sutcliffe, E.M., Rios, R., Fox, A.J., and Curry, A. (1993) *Campylobacter jejuni* adapts to aerobic metabolism in the environment. *J Med Microbiol* **38**: 145–150.
- Khan, N.A. (2006) *Acanthamoeba*: biology and increasing importance in human health. *FEMS Microbiol Rev* **30**: 564–595.
- Kinner, N.E., Harvey, R.W., Blakeslee, K., Novarino, G., and Meeker, L.D. (1998) Size-selective predation on groundwater bacteria by Nanoflagellates in an organic-contaminated aquifer. *Appl Environ Microbiol* **64**: 618–625.
- Korlath, J.A., Osterholm, M.T., Judy, L.A., Forfang, J.C., and Robinson, R.A. (1985) A point-source outbreak of campylobacteriosis associated with consumption of raw milk. *J Infect Dis* **152**: 592–596.
- Landers, P., Kerr, K.G., Rowbotham, T.J., Tipper, J.L., Keig, P.M., Ingham, E., and Denton, M. (2000) Survival and growth of *Burkholderia cepacia* within the free-living amoeba *Acanthamoeba polyphaga*. *Eur J Clin Microbiol Infect Dis* **19**: 121–123.
- Laskowski-Arce, M.A., and Orth, K. (2008) *Acanthamoeba castellanii* promotes the survival of *Vibrio parahaemolyticus*. *Appl Environ Microbiol* **74**: 7183–7188.
- Marciano-Cabral, F., and Cabral, G. (2003) *Acanthamoeba* spp. as agents of disease in humans. *Clin Microbiol Rev* **16**: 273–307.
- Marolda, C.L., Huroder, B., John, M.A., Michel, R., and Valvano, M.A. (1999) Intracellular survival and saprophytic growth of isolates from the *Burkholderia cepacia* complex in free-living amoebae. *Microbiology* **145**: 1509–1517.
- Matz, C., Deines, P., Boenigk, J., Arndt, H., Eberl, L., Kjelleberg, S., and Jurgens, K. (2004) Impact of violacein-producing bacteria on survival and feeding of bacterivorous Nanoflagellates. *Appl Environ Microbiol* **70**: 1593–1599.
- Molmeret, M., Horn, M., Wagner, M., Santic, M., and Abu Kwaik, Y. (2005) Amoebae as training grounds for intracellular bacterial pathogens. *Appl Environ Microbiol* **71**: 20–28.
- Myszewski, M.A., and Stern, N.J. (1991) Phagocytosis and intracellular killing of *Campylobacter jejuni* by elicited chicken peritoneal macrophages. *Avian Dis* **35**: 750–755.
- Naito, M., Firdich, E., Fields, J.A., Pryjma, M., Li, J., Cameron, A., et al. (2010) Effects of sequential *Campylobacter jejuni* 81-176 lipooligosaccharide core truncations on biofilm formation, stress survival, and pathogenesis. *J Bacteriol* **192**: 2182–2192.
- Neumeister, B. (2004) Intracellular multiplication of *Legionella* species and the influence of amoebae on their intracellular growth in human monocytes. In *Public Health Microbiology*. Spencer, J.F.T., and Spencer, A.L.R. (eds). Totowa, NJ, USA: Humana Press, pp. 141–151.
- Palyada, K., Sun, Y.-Q., Flint, A., Butcher, J., Naikare, H., and Stintzi, A. (2009) Characterization of the oxidative stress stimulon and PerR regulon of *Campylobacter jejuni*. *BMC Genomics* **10**: 481.
- Reuter, M., Mallett, A., Pearson, B.M., and van Vliet, A.H.M. (2010) Biofilm formation by *Campylobacter jejuni* is increased under aerobic conditions. *Appl Environ Microbiol* **76**: 2122–2128.
- Schuster, F.L. (2002) Cultivation of pathogenic and opportunistic free-living amoebae. *Clin Microbiol Rev* **15**: 342–354.
- Slabbert, J.L., and Morgan, W.S.G. (1982) A bioassay technique using *Tetrahymena pyriformis* for the rapid assessment of toxicants in water. *Water Res* **16**: 517–523.
- Snelling, W., Stern, N., Lowery, C., Moore, J., Gibbons, E., Baker, C., and Dooley, J. (2008) Colonization of broilers by *Campylobacter jejuni* internalized within *Acanthamoeba castellanii*. *Arch Microbiol* **189**: 175–179.

- Snelling, W.J., McKenna, J.P., Lecky, D.M., and Dooley, J.S.G. (2005) Survival of *Campylobacter jejuni* in waterborne protozoa. *Appl Environ Microbiol* **71**: 5560–5571.
- Stintzi, A. (2003) Gene expression profile of *Campylobacter jejuni* in response to growth temperature variation. *J Bacteriol* **185**: 2009–2016.
- Teh, K.H., Flint, S., and French, N. (2010) Biofilm formation by *Campylobacter jejuni* in controlled mixed-microbial populations. *Int J Food Microbiol* **143**: 118–124.
- Vercellone, P.A., Smibert, R.M., and Krieg, N.R. (1990) Catalase activity in *Campylobacter jejuni*: comparison of a wild-type strain with an aerotolerant variant. *Can J Microbiol* **36**: 449–451.
- Vezzulli, L., Pruzzo, C., Huq, A., and Colwell, R.R. (2010) Environmental reservoirs of *Vibrio cholerae* and their role in cholera. *Environ Microbiol Rep* **2**: 27–33.
- Watson, R.O., and Galán, J.E. (2008) *Campylobacter jejuni* survives within epithelial cells by avoiding delivery to lysosomes. *PLoS Pathog* **4**: e14.
- Weekers, P.H.H., Bodelier, P.L.E., Wijen, J.P.H., and Vogels, G.D. (1993) Effects of grazing by the free-living soil amoebae *Acanthamoeba castellanii*, *Acanthamoeba polyphaga*, and *Hartmannella vermiformis* on various bacteria. *Appl Environ Microbiol* **59**: 2317–2319.
- Wilson, D.F., Erecińska, M., Drown, C., and Silver, I.A. (1979) The oxygen dependence of cellular energy metabolism. *Arch Biochem Biophys* **195**: 485–493.
- Winiiecka-Krusnell, J., and Linder, E. (2001) Bacterial infections of free-living amoebae. *Res Microbiol* **152**: 613–619.
- Yuki, N. (2001) Infectious origins of, and molecular mimicry in, Guillain-Barré and Fisher syndromes. *Lancet Infect Dis* **1**: 29–37.
- Zhao, S., Young, S.R., Tong, E., Abbott, J.W., Womack, N., Friedman, S.L., and McDermott, P.F. (2010) Antimicrobial

resistance of *Campylobacter* isolates from retail meat in the United States between 2002 and 2007. *Appl Environ Microbiol* **76**: 7949–7956.

Supporting information

Additional Supporting Information may be found in the online version of this article:

Video S1. The motility of *C. jejuni* in the vacuole of *A. castellanii*. Before infection, *C. jejuni* cells were incubated at 37°C in amoeba buffer in microaerophilic conditions for 45 min with a final concentration of 10 µg ml⁻¹ of Celltracker Red CMTPX (Invitrogen, Burlington, ON, Canada) according to the manufacturer's recommendations. For labelling of acidic vacuoles, infected *A. castellanii* monolayers were stained with 10 µM LysoSensor Green DND-189 (Invitrogen, Burlington, ON, Canada) for 30 min before each time point according to the manufacturer's recommendations. All assays were carried out in the dark to avoid photobleaching of labelled cells. Motile *C. jejuni* cells within the amoebae immediately after gentamicin treatment at 25°C in aerobic conditions were tracked using time-lapse confocal laser-scanning microscope (Zeiss LSM-510 system with inverted Axiovert 200 M microscope), equipped with argon and helium-neon lasers, under 63 × objective. Three frames were taken every second and the size of the movie frame corresponds to 512 × 512 µm. The colour yellow was formed with the merging of green (lysosomes) and red (*C. jejuni*).

Please note: Wiley-Blackwell are not responsible for the content or functionality of any supporting materials supplied by the authors. Any queries (other than missing material) should be directed to the corresponding author for the article.

Chapter 6: The impacts of a common soil flagellate on the survival of three different food-borne pathogens (*C. jejuni*, *S. Typhimurium*, *L. monocytogenes*)

This chapter focuses on the investigation of the impacts of a common soil flagellate on the survival of three different food-borne pathogens (*C. jejuni*, *S. Typhimurium*, *L. monocytogenes*). The results of this study have been submitted for publication.

Bui XT, Wolff A, Madsen M and Bang DD (2012) **Interaction between food-borne pathogens (*Campylobacter jejuni*, *Salmonella Typhimurium* and *Listeria monocytogenes*) and a common soil flagellate (*Cercomonas* sp.). Accepted for publication**

Interaction between food-borne pathogens (*Campylobacter jejuni*, *Salmonella Typhimurium* and *Listeria monocytogenes*) and a common soil flagellate (*Cercomonas* sp.)

Xuan Thanh Bui¹, Anders Wolff², Mogen Madsen³ and Dang Duong Bang^{1,4*}

1) *Laboratory of Applied Micro and Nanotechnology (LAMINATE), National Veterinary Institute (VET), Technical University of Denmark (DTU). Hangøvej 2, DK-8200 Aarhus N, Denmark.*

2) *BioLabChip group, DTU-Nanotech (Department of Micro and Nanotechnology), Technical University of Denmark (DTU). Building 345 East, DK-2800 Kgs Lyngby, Denmark*

3) *DIANOVA, Technical University of Denmark (DTU), Denmark*

4) *Laboratory of Applied Micro and Nanotechnology (LAMINATE), National Food Institute (DTU Food), Technical University of Denmark (DTU). Mørkhøj Bygade 19, DK-2860 Søborg, Denmark.*

*Corresponding author:

Dang Duong Bang, PhD; senior scientist

Laboratory of Applied Micro-Nanotechnology (LAMINATE)

National Food Institute (DTU Food),

Technical University of Denmark (DTU)

Mørkhøj Bygade 19

DK-2860 Søborg

Denmark.

Telephone: +45 35886892

E-mail address: ddba@food.dtu.dk

Running title: Food-borne pathogens and flagellate interaction

Abstract

Free-living protozoa may harbor, protect, and disperse bacteria, including those ingested and passed in viable form in feces. The flagellates are very important predators on bacteria in soil, but their role in the survival of food-borne pathogens associated with fruits and vegetables is not well addressed. In this study, we investigated the interactions between a common soil flagellate, *Cercomonas* sp., and three different bacterial pathogens (*Campylobacter jejuni*, *Salmonella* Typhimurium, and *Listeria monocytogenes*). Rapid growth of flagellate was observed in co-culture with *C. jejuni* and *S. Typhimurium* over the time course of 15 days. In contrast, the number of *Cercomonas* sp. cells decreased when grown with or without *L. monocytogenes* for 9 days of co-culture. Interestingly, we observed that *C. jejuni* and *S. Typhimurium* survived better when co-cultured with flagellates than when cultured alone. The results of this study suggest that *Cercomonas* sp. and perhaps other soil flagellates may play a role for the survival of food-borne pathogens on plant surfaces and in soil.

Keywords: *Cercomonas* sp., *C. jejuni*, *L. monocytogenes*, *S. Typhimurium*, flagellate

1. Introduction

Outbreaks of food-borne illnesses caused by *Campylobacter*, *Salmonella* or *Listeria* associated with the consumption of contaminated vegetables have recently been reported and received worldwide attention (Beuchat, 1996; Crook et al., 2003; Pakalniskiene et al., 2009; Gajraj, Pooransingh, Hawker, & Olowokure, 2011; Gardner et al., 2011). Fresh produce consumed raw or minimally processed, such as fruits and vegetables, provide an ideal route for the transmission of certain enteric pathogenic bacteria including *Salmonella* spp., *Escherichia coli*, *Campylobacter jejuni*, and *Listeria monocytogenes* (Beuchat, 2002; Islam et al., 2004; Berger et al., 2010; Newell et al., 2010; Brassard, Guévremont, Gagné, & Lamoureux, 2011). Primary sources of pre-harvest contamination include soil-improvement with untreated or improperly composted manure and contaminated irrigation water (Buck, Walcott, & Beuchat, 2003; Islam et al., 2004; Berger et al., 2010; McLaughlin, Casey, Cotter, Gahan, & Hill, 2011). It has been reported that the microbiota of soil-grown fruits and vegetables may be reflecting the microbiota of soils in which they grow (Jay, Loessner, & Golden, 2005).

Protozoa, of which four broad categories ciliates, flagellates, exist, and amoebae, are the primary bacterial predators in soil. Of these groups, flagellates and amoebae are thought to be the most abundant and are able to enter soil pore necks as small as 3 μm (Ekelund & Rønn, 1994; Gaze, Burroughs, Gallagher, & Wellington, 2003). Flagellates as well as amoebae are important bacterial grazers, and flagellates have been shown to change the composition of the bacterial community in a different manner than the soil amoebae *Acanthamoebae* spp. They play an important role in microbial degradation processes and nutrient flow in soil (Pedersen, Nybroe, Winding, Ekelund, & Bjørnlund, 2009). Recent studies have suggested that free-living amoebae are important players in the evolution of obligate and facultative bacteria pathogens (Zhou, Elmore, & Call, 2007).

Although it has been shown that amoebae can prolong the survival of food-borne pathogens (Gaze et al., 2003; Zhou et al., 2007; Baré et al., 2010), relatively little is known about the role of flagellates in the epidemiology of food-borne diseases. Furthermore, it has been reported that flagellates appeared to be present in high numbers of vegetables such as lettuce and spinach (Gourabathini, Brandl, Redding, Gunderson, & Berk, 2008; Vaerewijck, Sabbe, Baré, & Houf, 2011). These protists ingest only a few bacteria at a time and their role in the survival of food-borne pathogens on plant surface and in soil remains to be investigated (Gourabathini et al., 2008). Accordingly, we investigated the ability of three different food-borne pathogens (*C. jejuni*, *S. Typhimurium*, and *L. monocytogenes*) to survive in co-culture with *Cercomonas* sp - a common soil flagellate. These bacterial pathogens were selected because they have caused recent outbreaks (Beuchat, 1996; Crook et al., 2003; Gajraj, Pooransingh, Hawker, & Olowokure, 2011; Gardner et al., 2011). Although flagellates are the most abundant and widespread soil mesofauna, relatively little is known regarding the impact of this free-living protozoan on fresh produce.

2. Materials and Methods

2.1. Bacteria and conditions

The reference strains of *C. jejuni* NCTC 11168, *L. monocytogenes* VDL 148, and *S. Typhimurium* NCTC 12023 were used in this study to investigate the interactions of these pathogens with a common soil flagellate, *Cercomonas* sp. Before each experiment, *C. jejuni* was grown under microaerophilic conditions for 24 h on blood agar (BA) plates (Trypic soy agar containing 5% [vol/vol] whole sheep blood, 10 µg/ml vancomycin and 5 µg/ml trimethoprim) at 37°C. *L. monocytogenes* and *S. Typhimurium* were grown on BA plates for 16 h in aerobic conditions.

2.2. Protozoan

The flagellate *Cercomonas* sp. reference strain ATCC 50334 was used as an axenic culture and is maintained at 15°C on a mixture of heat-killed cells of a soil isolate *Pseudomonas putida* reference strain ATCC 17426 as *Pseudomonas* spp. can be a food source of *Cercomonas* sp. as previously described (Pedersen et al., 2009) and a nutrient medium (ATCC medium 802). The bacteria were harvested and washed twice with modified Neff's Amoeba Saline (AS) buffer (Lekfeldt & Rønn, 2008) and then killed at 80°C for 15 min. The heterotrophic flagellate *Cercomonas* sp. cells from an actively growing axenic culture was washed three times with AS buffer and subsequently added to 25 cm² cell culture flask (Nunc, Roskilde, Denmark) containing 5 ml of ATCC medium 802 to reach the final concentration of 2×10³ flagellate cells/ml.

2.3. Co-culture experiments

An inoculum of each food-borne pathogen was added to separate flagellate flask with an estimated starting concentration of 10⁸ CFU/ml. For control experiments, 100 µl of 5×10⁹ CFU/ml heat-killed *P. putida* was added to a flagellate flask as a positive control, while 100 µl of AS buffer was added to another flagellate flask as a negative control. All flasks were incubated at 15°C in aerobic conditions. The number of bacterial cells and flagellates were determined at day 3, 6, 9, 12, and 15 of the co-cultures.

2.4. Survival of bacteria and flagellate

The growth of the flagellate was measured by counting the concentration of flagellates (cells/ml) at different time points in the cell culture flasks using an inverted light microscope with LED illumination at ×200 magnification (Leica DM IL LED, Leica Microsystems GmbH, Wetzlar, Germany). For *C. jejuni*, aliquots of 100 µl of 10-fold serial dilutions of co-culture medium were spotted on BA plates and incubated at 37°C in microaerophilic conditions for 36 h until bacterial colonies formed. For *S. Typhimurium* and *L. monocytogenes*, aliquots of 100 µl of 10-fold serial

dilutions of co-culture were spread on BA plates and incubated at 37°C in aerobic conditions for 16 and 24 h, respectively.

2.5. Statistical analysis

A Student's *t*-test was used to compare the numbers of bacteria in co-culture. *P*-values of < 0.05 were considered statistically significant.

3. Results and discussion

To investigate the interaction of food-borne pathogens with flagellates, we first determined whether these bacteria have an effect on the growth of *Cercomonas* sp. As shown in Fig. 1, the flagellate *Cercomonas* sp. did not grow in the co-culture with *L. monocytogenes* and lost the viability after day 3 and decreased more after 6 days until no cells were detectable by day 12. There was no significant difference in the number of *Cercomonas* sp. cells when cultivated with or without *L. monocytogenes* for flagellate cells rapidly decreased over time in both cases (Fig. 1). Interestingly, the rapid growth of flagellates was observed in the co-culture with *C. jejuni* and *S. Typhimurium* as well as in a positive control with adding heat-killed *P. putida*. The numbers of flagellates counted in flasks cultivated with *C. jejuni* and *S. Typhimurium* were almost equal to numbers of flagellate cells obtained in positive control flasks where heat-killed *P. putida* was added over the time course of 15 days. These results are in agreement with a previous study that described Gram-negative bacteria including *Pseudomonas* spp. as a good food source for the growth of *Cercomonas* sp. (Lekfeldt & Rønn, 2008; Pedersen et al., 2009).

The effect of flagellates on survival of food-borne pathogens in co-culture was determined by conventional bacterial plate counting (CFU) at different time points. As shown in Fig. 2, no significant difference was obtained with the number of *L. monocytogenes* cultivated with or without *Cercomonas* sp. after 12 days (Fig. 2). This corresponded well to the decreased number of

Cercomonas sp. cells, suggesting that this bacterium is not a food source and may be toxic for the flagellates. Cytotoxicity of haemolytic *Listeria* spp. in protozoa was originally demonstrated by (Ly & Muller, 1990). They have shown that haemolytic *L. monocytogenes* and *L. seeligeri* induce lysis of *Tetrahymena pyriformis* and *Acanthamoeba castellanii* during 8-15 days, while only few protozoa underwent lysis in the presence of non-haemolytic *L. innocua*. Interestingly, the number of *C. jejuni* cells in co-culture with *Cercomonas* sp. decreased slowly and remained approximately 2×10^2 CFU/ml at day 15. This corresponded well to the higher final number of flagellate cells when grown with this bacterium of apparent high food source (Fig. 1). In contrast, in the absence of flagellates, CFU number of *C. jejuni* decreased rapidly and 2.6×10^4 and 3.4×10^2 CFU/ml were obtained at day 3 and day 6, respectively. The number of *S. Typhimurium* cells obtained in the co-culture with *Cercomonas* sp. was significantly higher ($P < 0.05$) than those obtained in the culture without flagellates on day 9, 12 and 15 (Fig. 2). This bacterium seems to be a good source for the flagellate as a higher number of *Cercomonas* sp. was observed over the time course of 15 days. Although flagellates ingest *C. jejuni* and *S. Typhimurium* in the co-cultures, these bacteria still seem to survive longer in the presence of this protozoan than when cultivated without protozoan. Our data suggest that the flagellates use *C. jejuni* and *S. Typhimurium* as food sources, but there seems to be a mutual benefit in the relationship. By enhancing bacterial survival, the protozoa do not run out of food, while the bacteria “enjoy” the more favorable conditions generated by the flagellates and use the flagellates as temporary protective structures and vehicles for dissemination. It has been reported that flagellates ingest only a few bacteria at a time (Gourabathini et al., 2008), and thus they do not hinder the survival of *C. jejuni* and *S. Typhimurium*, which are in agreement with our data. Our data suggest that flagellates may play a role in the transmission of food-borne pathogens as they may enter the human food chain following the application of animal manures to agricultural land with raw consumed crops such as salads, fruit and vegetables. Furthermore, it has

been reported that food-borne pathogens originating from animal manures could survive for a long time in soil after application (Nicholson, Groves, & Chambers, 2005). Alongside amoebae which have been demonstrated to promote the survival of these pathogens (Gaze et al., 2003; Baré et al., 2010), our study suggests that flagellates also may play a similar role as amoebae.

Observations reported here demonstrate that *Cercomonas* sp., a common soil flagellate, is strongly attracted to and consumes both *C. jejuni* and *S. Typhimurium* which can be introduced into agricultural soil through the deposition of animal faeces, untreated irrigation water, or runoff water from livestock feeding lots (Islam et al., 2004; Berger et al., 2010). Our data indicate that *Cercomonas* sp. consumed *C. jejuni* and *S. Typhimurium* as food sources but not *L. monocytogenes*. Furthermore, *Cercomonas* sp. not only consumed but also significantly prolonged the survival of both *C. jejuni* and *S. Typhimurium* in co-culture up to 15 days while *L. monocytogenes* died after 3-6 days. We did not determine the internal location of bacterial pathogens inside *Cercomonas* sp., but our data support and suggest that by prolonging the survival of bacterial pathogens when cultivated with *Cercomonas* sp. can open a window for the possibility of a cross contamination of these pathogens from soil to human food chains. The cross contamination could be due to *Cercomonas* sp. itself as a vector carrying over but it needs to be proved and examined by different methods. In addition, prolonging the survival of food-borne pathogens in soil by *Cercomonas* sp. could increase the risk of other protozoa, insects, worms or wild birds to be a vector for the pathogens. Also, it is very interesting to study what factors contribute to prolong the survival of the bacterial pathogens in co-culture with *Cercomonas* sp. The experiments in this direction are in progress. Furthermore, the results of this study could open a new direction for studying the interaction between protozoa and bacterial pathogens from the environments such as fertilized soil, water and animal manures to human foods, specially the consumption of raw crops.

Acknowledgements

This study was supported by the Pathos Project funded by the Strategic Research Council of Denmark (ENV 2104-07-0015). We thank Dr. Anne Winding for kindly providing us the *Cercomonas* sp. strain.

References

Baré, J., Sabbe, K., Huws, S., Vercauteren, D., Braeckmans, K., Van Gremberghe, I. Favoreel, H., & Houf, K. (2010). Influence of temperature, oxygen and bacterial strain identity on the association of *Campylobacter jejuni* with *Acanthamoeba castellanii*. *FEMS Microbiology Ecology*, 74, 371-381. <http://dx.doi.org/10.1111/j.1574-6941.2010.00955.x>

Berger, C. N., Sodha, S. V., Shaw, R. K., Griffin, P. M., Pink, D., Hand, P., & Frankel, G. (2010). Fresh fruit and vegetables as vehicles for the transmission of human pathogens. *Environmental Microbiology*, 12, 2385-2397. <http://dx.doi.org/10.1111/j.1462-2920.2010.02297.x>

Beuchat, L. R. (1996). *Listeria monocytogenes*: incidence on vegetables. *Food Control*, 7, 223-228. [http://dx.doi.org/10.1016/s0956-7135\(96\)00039-4](http://dx.doi.org/10.1016/s0956-7135(96)00039-4)

Beuchat, L. R. (2002). Ecological factors influencing survival and growth of human pathogens on raw fruits and vegetables. *Microbes and Infection*, 4, 413-423. [http://dx.doi.org/10.1016/s1286-4579\(02\)01555-1](http://dx.doi.org/10.1016/s1286-4579(02)01555-1)

Brassard, J., Guévremont, É., Gagné, M.-J., & Lamoureux, L. (2011). Simultaneous recovery of bacteria and viruses from contaminated water and spinach by a filtration method. *International Journal of Food Microbiology*, 144, 565-568. <http://dx.doi.org/10.1016/j.ijfoodmicro.2010.11.015>

Buck, J. W., Walcott, R. R., & Beuchat, L. R. (2003). Recent trends in microbiological safety of fruits and vegetables. *Plant Health Progress*. <http://dx.doi.org/10.1094/PHP-2003-0121-01-RV>.

Crook, P.D., Aguilera, J. F., Threlfall, E. J., O'Brien, S. J., Sigmundsdóttir, G., Wilson, D., Fisher, I. S. T., Ammon, A., Briem, H., Cowden, J. M., Locking, M. E., Tschäpe, H., Van Pelt, W., Ward, L. R., & Widdowson, M. A. (2003). A European outbreak of *Salmonella enterica* serotype Typhimurium definitive phage type 204b in 2000. *Clinical Microbiology and Infection*, 9, 839-845. <http://dx.doi.org/10.1046/j.1469-0691.2003.00655.x>

Ekelund, F., & Rønn, R. (1994). Notes on protozoa in agricultural soil with emphasis on heterotrophic flagellates and naked amoebae and their ecology. *FEMS Microbiology Reviews*, 15, 321-353. [http://dx.doi.org/10.1016/0168-6445\(94\)90068-x](http://dx.doi.org/10.1016/0168-6445(94)90068-x)

Gajraj, R., Pooransingh, S., Hawker, J. I., & Olowokure, B. (2011). Multiple outbreaks of *Salmonella braenderup* associated with consumption of iceberg lettuce. *International Journal of Environmental Health Research*, 1-6. <http://dx.doi.org/10.1080/09603123.2011.613114>

Gardner, T. J., Fitzgerald, C., Xavier, C., Klein, R., Pruckler, J., Stroika, S., & McLaughlin, J. B. (2011). Outbreak of campylobacteriosis associated with consumption of raw peas. *Clinical Infectious Diseases*, 53, 26-32. <http://dx.doi.org/10.1093/cid/cir249>

Gaze, W. H., Burroughs, N., Gallagher, M. P., & Wellington, E. M. H. (2003). Interactions between *Salmonella typhimurium* and *Acanthamoeba polyphaga*, and observation of a new mode of intracellular growth within contractile vacuoles. *Microbial Ecology*, 46, 358-369. <http://dx.doi.org/10.1007/s00248-003-1001-3>

Gourabathini, P., Brandl, M. T., Redding, K. S., Gunderson, J. H., & Berk, S. G. (2008). Interactions between food-borne pathogens and protozoa isolated from lettuce and spinach. *Applied and Environmental Microbiology*, 74, 2518-2525. <http://dx.doi.org/10.1128/aem.02709-07>

Islam, M., Morgan, J., Doyle, M. P., Phatak, S. C., Millner, P., & Jiang, X. (2004). Persistence of *Salmonella enterica* serovar Typhimurium on lettuce and parsley and in soils on which they were grown in fields treated with contaminated manure composts or irrigation water. *Foodborne Pathogens and Disease*, 1, 27-35. <http://dx.doi.org/10.1089/153531404772914437>

Jay, J. M., Loessner, M. J., & Golden, D. A. (2005). Taxonomy, role, and significance of microorganisms in foods modern food microbiology (pp. 13-37). In: Springer US, http://dx.doi.org/10.1007/0-387-23413-6_2

Lekfeldt, J. D. S., & Rønn, R. (2008). A common soil flagellate (*Cercomonas* sp.) grows slowly when feeding on the bacterium *Rhodococcus fascians* in isolation, but does not discriminate against it in a mixed culture with *Sphingopyxis wittflariensis*. *FEMS Microbiology Ecology*, 65, 113-124. <http://dx.doi.org/10.1111/j.1574-6941.2008.00486.x>

Ly, T. M. C., & Muller, H. E. (1990). Ingested *Listeria monocytogenes* survive and multiply in protozoa. *Journal of Medical Microbiology*, 33, 51-54. <http://dx.doi.org/10.1099/00222615-33-1-51>

McLaughlin, H., Casey, P., Cotter, J., Gahan, C., & Hill, C. (2011). Factors affecting survival of *Listeria monocytogenes* and *Listeria innocua* in soil samples. *Archives of Microbiology*, 193, 775-785. <http://dx.doi.org/10.1007/s00203-011-0716-7>

Newell, D. G., Koopmans, M., Verhoef, L., Duizer, E., Aidara-Kane, A., Sprong, H. Opsteegh, M., Langelaar, M., Threlfall, J., Scheutz, F., der Giessen, J. V., & Kruse, H. (2010). Food-borne diseases -The challenges of 20 years ago still persist while new ones continue to emerge. *International Journal of Food Microbiology*, 139, S3-S15. <http://dx.doi.org/10.1016/j.ijfoodmicro.2010.01.021>

Nicholson, F. A., Groves, S. J., & Chambers, B. J. (2005). Pathogen survival during livestock manure storage and following land application. *Bioresource Technology*, 96, 135-143. <http://dx.doi.org/10.1016/j.biortech.2004.02.030>

Pakalniskiene, J., Falkenhorst, G., Lisby, M., Madsen, S. B., Olsen, K. E. P., Nielsen, E. M., Mygh, A., Boel, J., & Mølbak, K. (2009). A foodborne outbreak of enterotoxigenic *E. coli* and *Salmonella* Anatum infection after a high-school dinner in Denmark, November 2006. *Epidemiology and Infection*, 137, 396-401. <http://dx.doi.org/10.1017/S0950268808000484>

Pedersen, A., Nybroe, O., Winding, A., Ekelund, F., & Bjørnlund, L. (2009). Bacterial feeders, the nematode *Caenorhabditis elegans* and the flagellate *Cercomonas longicauda*, have different effects on outcome of competition among the *Pseudomonas* biocontrol strains CHA0 and DSS73. *Microbial Ecology*, 57, 501-509. <http://dx.doi.org/10.1007/s00248-008-9455-y>

Vaerewijck, M. J. M., Sabbe, K., Baré, J., & Houf, K. (2011). Occurrence and diversity of free-living protozoa on butterhead lettuce. *International Journal of Food Microbiology*, 147, 105-111. <http://dx.doi.org/10.1016/j.ijfoodmicro.2011.03.015>

Zhou, X., Elmoose, J., & Call, D. R. (2007). Interactions between the environmental pathogen *Listeria monocytogenes* and a free-living protozoan (*Acanthamoeba castellanii*). *Environmental Microbiology*, 9, 913-922. <http://dx.doi.org/10.1111/j.1462-2920.2006.01213.x>

Figure legends

Figure 1. Growth of flagellates in co-culture with or without bacteria at different time points at 15°C in aerobic conditions. Data are means and standard errors of at least three independent experiments.

Figure 2. The survival of food-borne pathogens in co-culture with or without *Cercomonas* sp. at different time points at 15°C in aerobic conditions. CFU counts are present as (A) *C. jejuni*, (B) *S. Typhimurium*, and (C) *L. monocytogenes*. Data are means and standard errors of at least three independent experiments.

Figure 1.

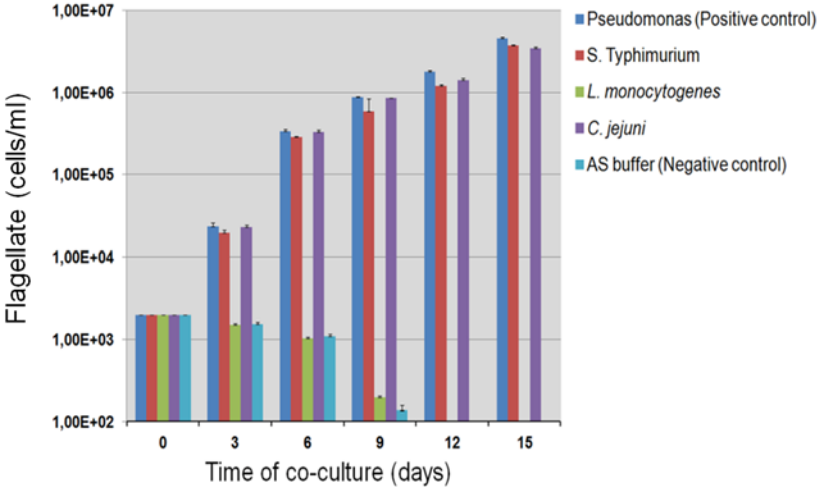
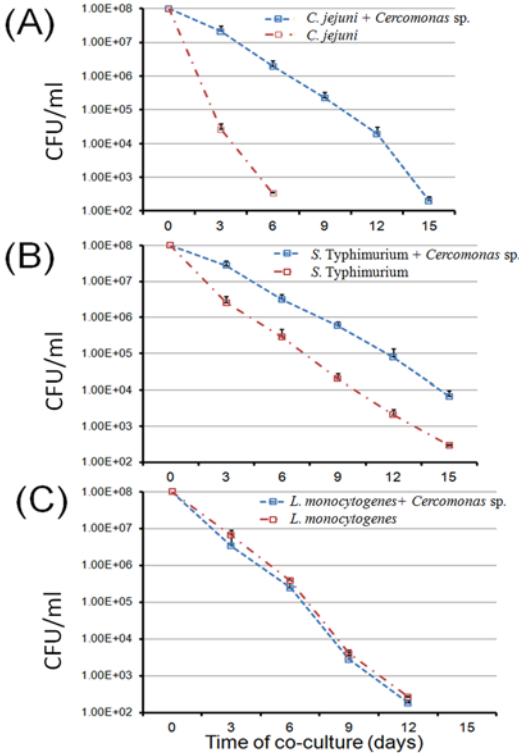

Figure 2.



Chapter 7: The impacts of environmental stresses on uptake and survival of *C. jejuni* in *A. castellanii*

This chapter focuses on the impacts of environmental stresses on uptake and survival of *C. jejuni* in *A. castellanii*. The mechanism involved in phagocytosis and killing of *C. jejuni* by *A. castellanii* was investigated. The results of this work have been submitted for publication.

Bui XT, Qvortrup K, Wolff A, Bang DD, and Creuzenet C (2012) **The effect of environmental stress factors on the uptake and survival of *Campylobacter jejuni* in *Acanthamoeba castellanii*.**
Submitted



<http://mc.manuscriptcentral.com/fems>

The effect of environmental stress factors on the uptake and survival of *Campylobacter jejuni* in *Acanthamoeba castellanii*.

Journal:	<i>FEMS Microbiology Ecology</i>
Manuscript ID:	FEMSEC-12-02-0066
Manuscript Type:	Research Paper
Date Submitted by the Author:	06-Feb-2012
Complete List of Authors:	Bui, Xuan; Technical University of Denmark, Laboratory of Applied Micro and Nanotechnology Qvortrup, Klaus; University of Copenhagen, Biomedical Sciences Wolff, Anders; Technical University of Denmark, Micro and Nanotechnology Creuzenet, Carole; University of Western Ontario, Microbiology and Immunology Dang, Bang; National Veterinary Institute, Poultry, Fish and Fur Animals; Technical University of Denmark, Laboratory of Applied Micro and Nanotechnology
Keywords:	<i>Campylobacter jejuni</i>, <i>Acanthamoeba castellanii</i>, environmental stresses, virulence

SCHOLARONE™
Manuscripts

1
2
3
4
5
6
7
8
9
10
11
12
13
14
15
16
17
18
19
20
21
22
23
24
25
26
27
28
29
30
31
32
33
34
35
36
37
38
39
40
41
42
43
44
45
46
47
48
49
50
51
52
53
54
55
56
57
58
59
60

1 **The effect of environmental stress factors on the uptake and survival of**
2 ***Campylobacter jejuni* in *Acanthamoeba castellanii***

3 Xuan Thanh Bui^{1,4}, Klaus Qvortrup², Anders Wolff³, Dang Duong Bang^{1,5} and Carole
4 Creuzenet^{4*}

5
6 1) Laboratory of Applied Micro and Nanotechnology (LAMINATE), National Veterinary
7 Institute (VET), Technical University of Denmark (DTU). Høngevej 2, DK-8200 Aarhus N,
8 Denmark.

9 2) Department of Biomedical Sciences, University of Copenhagen. Blegdamsvej 3B, 2200
10 Copenhagen N, Denmark

11 3) BioLabChip group, DTU-Nanotech (Department of Micro and Nanotechnology), Technical
12 University of Denmark (DTU). Building 345 East, DK-2800 Kgs Lyngby, Denmark

13 4) Department of Microbiology and Immunology, Infectious Diseases Research Group,
14 Dental Sciences Building, Room 3031, University of Western Ontario, London, ON, N6A 5C1,
15 Canada

16 5) Laboratory of Applied Micro and Nanotechnology (LAMINATE), National Food Institute
17 (DTU Food), Technical University of Denmark (DTU). Mørkhøj Bygade 19, DK-2860 Søborg,
18 Denmark

19
20 * Corresponding author: Dr. Carole Creuzenet, Associate Professor, Department of
21 Microbiology and Immunology, Dental Sciences Building, Room 3031, University of Western
22 Ontario, London, ON, N6A 5C1, Canada.

23 Telephone: +1-519 661 3204, Fax: +1-519 661 3499, e-mail: ccreuzenet@uwo.ca

24 Abstract

25 *Campylobacter jejuni* is a major cause of bacterial food-borne illness in Europe and North
26 America. Here, we examined the impact of environmental stresses on the expression of
27 virulence-associated genes (*ciaB*, *dnaJ*, and *htrA*) of *C. jejuni* and on its uptake by and
28 intracellular survival within *Acanthamoeba castellanii*. We observed that heat, starvation and
29 osmotic stresses reduced the survival of *C. jejuni* significantly, whereas oxidative stress had no
30 effect. Quantitative RT-PCR experiments showed that the transcription of virulence genes was
31 slightly up-regulated under heat and oxidative stresses but down-regulated under starvation and
32 osmotic stresses, the *htrA* gene showing the largest down-regulation in response to osmotic
33 stress. We also demonstrated that *C. jejuni* rapidly loses viability during its intra-amoeba stage
34 and that exposure of *C. jejuni* to environmental stresses did not promote its intracellular survival
35 in *A. castellanii*. Finally, we showed that phagocytosis of *C. jejuni* by *A. castellanii* involves
36 recruiting actin for internalization in the absence of PI 3-kinase-mediated signal, and that phago-
37 lysosome maturation may not be the primary factor for intra-amoeba killing of *C. jejuni*.
38 Together these findings suggest that the stress response in *C. jejuni* and its interaction with *A.*
39 *castellanii* are complex and multifactorial.

40 **Keyword:** *Campylobacter jejuni*, *Acanthamoeba castellanii*, environmental stresses, virulence.

43 Introduction

44 *Campylobacter jejuni* is a gram-negative and microaerophilic bacterium that is
45 considered the leading cause of human gastroenteritis worldwide (Blaser, 1997; Allos, 2001;

1
2
3 46 Newton and Surawicz, 2011). *C. jejuni* resides in the intestinal microflora of most mammals and
4
5 47 the gastrointestinal tract of broiler chickens in a commensal relationship with its host (Beery *et*
6
7
8 48 *al.*, 1988; Candon *et al.*, 2007). *C. jejuni* is typically transmitted to humans via consumption of
9
10 49 undercooked food, unpasteurized milk, or contaminated water, or via contact with infected
11
12 50 animals (Friedman *et al.*, 2000; Allos, 2001). Symptoms of campylobacteriosis include malaise,
13
14
15 51 fever, severe abdominal pain, and diarrhea, and are self-limited, usually resolving within a week
16
17 52 (Gundogdu *et al.*, 2011; Newton and Surawicz, 2011). However, severe bloody and mucoid
18
19
20 53 diarrhea can develop and campylobacteriosis has been correlated with other medical sequelae,
21
22 54 such as reactive arthritis, hemolytic-uremic syndrome, and inflammatory bowel disease; the most
23
24 55 notable complication of infection is Guillain-Barré Syndrome, an acute neuromuscular paralysis
25
26
27 56 (Hughes, 2004; Candon *et al.*, 2007). As it passes from host (commonly avian species) to human,
28
29 57 *C. jejuni* must survive a great range of hostile environmental stresses, including limited carbon
30
31 58 sources, suboptimal growth temperatures, and exposure to atmospheric oxygen. Specifically, as a
32
33
34 59 microaerophilic pathogen, *C. jejuni* must adapt to oxidative stress during transmission and
35
36 60 colonization. In addition, this bacterium may struggle to accumulate adequate amounts of
37
38
39 61 nutrients (Candon *et al.*, 2007; Jackson *et al.*, 2009; Klančnik *et al.*, 2009) during residence in
40
41 62 natural environments and during host colonization. In food processing, *C. jejuni* must overcome
42
43
44 63 high osmolarity conditions which are used for the inhibition of microbial growth (Alter and
45
46 64 Scherer, 2006). Furthermore, *C. jejuni* is able to adapt to a wide range of changing temperatures,
47
48 65 from 42°C in avian hosts to ambient environmental temperatures and ultimately 37°C in the
49
50 66 human host.

51
52
53
54 67 In order to survive these oxidative, starvation, osmotic and heat stresses, *C. jejuni* must be
55
56 68 able to sense these changes and respond accordingly (Fields and Thompson, 2008). The ability of

1
2
3
4 69 bacteria to alter protein synthesis is essential to respond and adapt to rapidly changing
5
6 70 environments (Ma *et al.*, 2009). For example, several studies have focused on determining the
7
8 71 mechanisms of *C. jejuni* survival at temperatures above 42°C. It has been shown that at least 24
9
10 72 proteins were up-regulated when cells were heat-shocked at temperatures ranging from 43 to
11
12 73 48°C (Konkel *et al.*, 1998). However, the genetic response of this bacterium to osmotic stress is
13
14 74 not well known. Overall, despite the prevalence of *C. jejuni* infections, the molecular
15
16 75 mechanisms that this pathogen uses to cause human disease, as well as the mechanisms utilized
17
18 76 to adapt to or survive environmental stresses encountered during both in vivo colonization and ex
19
20 77 vivo transmission, are not well understood. A better understanding of the regulation of *C. jejuni*
21
22 78 response mechanisms to the diverse stresses encountered during both the infection cycle and
23
24 79 within its natural environments is required in order to facilitate the development of appropriate
25
26 80 intervention strategies to reduce the burden of *C. jejuni*-associated diseases (Gundogdu *et al.*,
27
28 81 2011).

32
33
34
35 82 Aquatic environments are reservoirs for *C. jejuni* (Bolton *et al.*, 1982; Thomas *et al.*,
36
37 83 1999; Jackson *et al.*, 2009) and contaminated drinking water has been implicated in several *C.*
38
39 84 *jejuni* outbreaks (Thomas *et al.*, 2002; Clark *et al.*, 2003; Hanninen *et al.*, 2003). *Acanthamoeba*
40
41 85 spp. are free-living amoebae which can be found widely in water (Rohr *et al.*, 1998; Thomas *et*
42
43 86 *al.*, 2008; Thomas *et al.*, 2010). We and others have indicated that amoebae can promote the
44
45 87 survival of *C. jejuni* (Axelsson-Olsson *et al.*, 2005; Snelling *et al.*, 2005; Axelsson-Olsson *et al.*,
46
47 88 2010; Baré *et al.*, 2010; Bui *et al.*, 2011) and our study specifically showed that the bulk of this
48
49 89 growth was extracellular. In this previous study, we also showed that while the majority of
50
51 90 internalized *C. jejuni* does not survive ingestion by *A. castellanii* beyond 5 h, a very small
52
53 91 number of bacteria is able to survive intracellularly and is thereby protected from external

1
2
3 92 disinfectant killing during this time frame (Bui *et al.*, 2011). During this period, chicks may still
4
5 93 get contaminated by *Campylobacter* from infected amoebae present in the water source, as it has
6
7
8 94 been reported that intra-amoeba *Campylobacter* can colonize broiler chickens and may represent
9
10 95 a significant environmental source of transmission (Snelling *et al.*, 2008).
11
12

13
14 96 Although the mechanisms of survival of *C. jejuni* outside the host are not fully
15
16 97 understood, it has been proposed that stress-adapted *C. jejuni* can survive environmental stresses
17
18 98 better than non-stressed cells (Murphy *et al.*, 2003; Ma *et al.*, 2009). Likewise, pre-exposure to
19
20 99 stress may affect the interaction of stressed *C. jejuni* cells with amoeba. To date, little is known
21
22 100 about the interaction of stressed *C. jejuni* and *A. castellanii* but this needs to be investigated as
23
24
25 101 both of these organisms occupy a similar ecological habitat and their interactions are relevant to
26
27 102 the transmission of *C. jejuni* from the environment to new hosts.
28
29
30

31 103 *Acanthamoebae* have evolved efficient mechanisms to phagocytose and kill bacteria and
32
33 104 other cells that essentially serve as a source of nutrients (Bottone *et al.*, 1994; Schuster and
34
35 105 Visvesvara, 2004; Akya *et al.*, 2009). Phagocytosis is an actin-based process that involves
36
37 106 polymerization of monomeric G-actin to polymeric F-actin. This allows eukaryotic cells to
38
39 107 internalize small particles such as prokaryotic cells (Akya *et al.*, 2009). It has been shown that
40
41 108 actin microfilaments of eukaryotic cells are involved in the phagocytosis of *C. jejuni* in intestinal
42
43 109 cells and macrophages (Wassenaar *et al.*, 1997; Biswas *et al.*, 2000) and that phagosomal
44
45 110 acidification and phago-lysosome fusion are involved in the intracellular killing of this bacterium
46
47 111 (Biswas *et al.*, 2000; Watson and Galán, 2008). However, the exact mechanism involved in
48
49 112 phagocytosis and killing of *C. jejuni* by *A. castellanii* is not known yet.
50
51
52
53
54
55
56
57
58
59
60

1
2
3 113 The aims of this study were to: 1) investigate the effect of environmental stress factors,
4
5
6 114 namely osmotic, heat, oxidative, and low nutrient stresses on the extracellular survival of
7
8 115 expression of *C. jejuni* and on the transcription of virulence-associated genes (*htrA*, *ciaB*, *dnaJ*);
9
10
11 116 2) investigate the effect of these stresses on the uptake and intracellular survival of *C. jejuni* in *A.*
12
13 117 *castellanii* and 3) understand the mechanisms involved in phagocytosis and killing of *C. jejuni*
14
15 118 by *A. castellanii*.

18 119 **Materials and Methods**

20 120 **Microorganisms and culture conditions**

21
22
23 121 The reference strain *C. jejuni* ATCC 700819 (National Collection of Type Cultures
24
25 122 (NCTC) 11168) was obtained from the American Type Culture Collection. The *htrA* mutant was
26
27
28 123 a kind gift from Prof. Hanne Ingmer (University of Copenhagen, Denmark) and was previously
29
30 124 described (Brondsted *et al.*, 2005). Before each experiment, the bacteria were typically grown
31
32
33 125 under microaerophilic conditions for 24 h on conventional blood agar plates (Tryptic soy agar
34
35 126 containing 5% [vol/vol] whole sheep blood, 10 µg ml⁻¹ vancomycin and 5 µg ml⁻¹ trimethoprim)
36
37
38 127 at 37°C. For infection assays, bacterial cells were harvested and diluted in amoeba buffer or
39
40 128 peptone - yeast extract - glucose medium (PYG; 2% proteose peptone, 0.1% yeast extract, 4 mM
41
42 129 MgSO₄·7H₂O, 0.4 mM CaCl₂, 0.05 mM Fe(NH₄)₂(SO₄)₂·6H₂O, 2.5 mM Na₂HPO₄·7H₂O, 2.5
43
44 130 mM KH₂PO₄, 0.1% sodium citrate dihydrate, and 0.1 M glucose, pH 6.5). Amoeba buffer was a
45
46
47 131 non-nutrient culture media for *A. castellanii* including 4 mM MgSO₄·7H₂O, 0.4 mM CaCl₂, 0.05
48
49 132 mM Fe(NH₄)₂(SO₄)₂·6H₂O, 2.5 mM Na₂HPO₄·7H₂O, 2.5 mM KH₂PO₄ but excluding peptone,
50
51 133 yeast extract, and glucose.
52
53
54
55
56
57
58
59
60

1
2
3 134 Amoeba reference strain *Acanthamoeba castellanii* ATCC 30234 was obtained from the
4
5
6 135 American Type Culture Collection. The protozoa were maintained in PYG medium in 75 cm²
7
8 136 tissue culture flasks (BD, Mississauga, ON, Canada) at 25°C without aeration. *A. castellanii* was
9
10
11 137 routinely subcultured every 5 days.

12 13 138 **Stress conditions**

14
15 139 *C. jejuni* cells were grown in microaerophilic conditions at 37°C on blood agar plates
16
17 140 overnight, collected by centrifugation at 6,000 rpm for 10 min, and washed twice in PBS. The
18
19
20 141 bacterial pellet was resuspended in Brucella broth and adjusted to an OD₆₀₀ of 1. Oxidative stress
21
22 142 assays were performed as previously described (Gundogdu *et al.*, 2011). Briefly, bacterial cells
23
24 143 were exposed to hydrogen peroxide (H₂O₂) at a final concentration of 10 mM for 15 min. For
25
26
27 144 heat stress assays, bacterial cells were resuspended in 3 ml Brucella broth and incubated at 42°C
28
29 145 for 30 min and shifted to 55°C for 3 min. For the osmotic stress assay, *C. jejuni* cells were
30
31
32 146 resuspended in 3 ml Brucella broth supplemented with NaCl to reach a final concentration of
33
34 147 1.5% and incubated at 37°C in microaerophilic conditions for 5 h. For low nutrient stress assays,
35
36 148 *C. jejuni* cells were grown in microaerophilic conditions at 37°C on blood agar plates overnight,
37
38
39 149 collected by centrifugation at 6,000 rpm for 10 min, and washed twice with amoeba buffer. The
40
41 150 bacteria were resuspended in 3 ml amoeba buffer and incubated at 37°C in microaerophilic
42
43
44 151 conditions for 5 h. A non-stressed *C. jejuni* culture, taken at the same time as the stressed culture,
45
46 152 served as the control. After exposure to each environmental stress, samples were collected and
47
48 153 10-fold serial dilutions were spotted on blood agar plates and incubated at 37°C in
49
50
51 154 microaerophilic conditions for 36 h until bacterial colonies formed.

52 53 155 **RNA extraction and reverse transcription assays**

1
2
3 156 After exposure to each artificial stress, samples were immediately collected for RNA
4
5
6 157 extraction. Total RNA was extracted as previously described but with a few exceptions (Bui *et*
7
8 158 *al.*, 2012). Briefly, 1 ml of each bacterial suspension was transferred to a microcentrifuge tube
9
10 159 and centrifuged at 8,000 *g* for 7 min. The bacterial pellets were mixed with 0.5 ml of
11
12 160 cetyltrimethylammonium bromide (CTAB) extraction buffer, 0.5 ml of phenol-chloroform-
13
14 161 isoamyl alcohol (25:24:1, pH 8.0). The lysate was centrifuged at 13,000 *g* for 5 min. The
15
16 162 aqueous phase was purified by chloroform-isoamyl alcohol (24:1) extraction. The mixture was
17
18 163 centrifuged at 13,000 *g* for 5 min. The volume of the aqueous phase was estimated and the
19
20 164 nucleic acids were precipitated by adding a 0.08 volume of chilled 7.5 M ammonium acetate and
21
22 165 a 0.54 volume of chilled isopropanol. The mixture, including any precipitate that may have
23
24 166 formed, was transferred to an RNeasy spin column placed in a 2 ml collection tube from the
25
26 167 RNeasy Mini RNA isolation kit (Qiagen, Copenhagen, Denmark) and centrifuged for 15 s at
27
28 168 8,000 *g*. Washing steps were followed according to the manufacturer's protocol. The RNA was
29
30 169 eluted in 35 μl of RNase-free water and treated with 0.3 U mL^{-1} of DNase I Amplification Grade
31
32 170 (Invitrogen, Denmark) according to the manufacturer's instruction. The treated RNA was
33
34 171 quantified using a NanoDrop 1000 spectrophotometer Thermo Scientific (Saveen Werner ApS,
35
36 172 Jyllinge, Denmark). The DNA-free RNA products were transcribed to complementary DNA
37
38 173 (cDNA) using the iScript™ cDNA Synthesis Kit (Bio-Rad, USA) with pre-mixed RNase
39
40 174 inhibitor and random hexamer primers, according to the manufacturer's instruction.
41
42
43
44
45
46
47

48 **Primer design and quantitative real-time PCR (qPCR) conditions**

49

50
51 176 The sequence of the *htrA* gene of *C. jejuni* (Genebank access number: NC_002163.1)
52
53 177 obtained from NCBI GenBank and used for primer design. After conducting a multiple sequence
54
55 178 alignment using the ClustalW program (Chenna *et al.*, 2003), a primer pair, namely *htrA-F/htrA-*
56
57
58
59
60

1
2
3 179 R, with sequences flanking the conserved regions of the *C. jejuni htrA* gene was designed using
4
5 180 the Primer 3 program (<http://frodo.wi.mit.edu/primer3/>). *ciaB*, *dnaJ* and *16S rRNA* primers were
6
7
8 181 obtained from a previous study (Li *et al.*, 2008). The sequences of all primers used in this study
9
10 182 are listed in Table 1.

11
12
13 183 qPCR assays were carried out in an Mx3005P thermocycler (Stratagene, Denmark). The
14
15 184 PCR mixtures (25 μ l) contained 5 μ l cDNA, 12.5 μ l of 2 \times PCR master mix (Promega,
16
17 185 Denmark), 400 nM of each primer and 50000 \times diluted SYBR green (Invitrogen, Denmark). The
18
19 186 qPCR conditions consisted of an initial heat-denaturing step at 94 $^{\circ}$ C for 5 min; followed by 45
20
21 187 cycles of denaturing at 94 $^{\circ}$ C for 15 s, annealing at 52 $^{\circ}$ C for 20 s, and extension at 72 $^{\circ}$ C for 15 s;
22
23 188 followed by an elongation step at 72 $^{\circ}$ C for 3 min. In every qPCR analysis, a negative control (5
24
25 189 μ l of water) and a positive DNA control (5 μ l) of *C. jejuni* DNA (2 ng/ μ l) were included. Each
26
27 190 specific PCR amplicon was verified by the presence of both a single melting-temperature peak
28
29 191 and a single band of expected size on a 2% agarose gel after electrophoresis. C_T values were
30
31 192 determined with the Mx3005P software (Stratagene, Denmark). The relative changes (x -fold) in
32
33 193 gene expression between the induced and calibrator samples were calculated using the $2^{-\Delta\Delta CT}$
34
35 194 method as previously described (Livak and Schmittgen, 2001). The *16S rRNA* gene was used as
36
37 195 the internal control as previously described (Klančnik *et al.*, 2006; Li *et al.*, 2008). qPCR assays
38
39 196 were performed using cDNA without dilution from three different RNA extracts of three
40
41 197 independent experiments.

42 198 **Amoeba infection assays and determination of survival of intracellular bacteria**

43
44 199 Co-cultures of *C. jejuni* with monolayers of amoeba cells were performed in 6-well tissue
45
46 200 plates (BD, Mississauga, ON, Canada). Logarithmic *A. castellanii* cultures in 75 cm² tissue
47
48 201 culture flasks were washed twice with phosphate buffered saline (PBS) and re-suspended in 25

1
2
3 202 ml of amoeba buffer by tapping the flask. Using this buffer, amoebae can survive but do not
4
5
6 203 multiply and will phagocytose the bacteria due to starvation. Amoebae were enumerated using a
7
8 204 Burker-Turk (Nitrin, Tokyo, Japan), diluted and seeded at a density of 2×10^6 amoeba cells per
9
10 205 ml in amoeba buffer in 6-well plates and incubated for 2 hours to allow the trophozoites to settle
11
12 206 and form a monolayer. The stressed and non-stressed bacterial cells were collected, washed, and
13
14
15 207 adjusted to an OD_{600} of 0.8. The washed bacterial cells were added to achieve a multiplicity of
16
17 208 infection (MOI) of ~100 bacterial cells per amoeba and the actual MOI was also calculated by
18
19 209 enumerating bacteria on blood agar plates. The 6-well plates were then centrifuged (1000 rpm, 3
20
21 210 min) to sediment the bacterial cells onto the surface of the trophozoites. Bacterial invasion was
22
23 211 permitted to continue for 3 h at 25°C in aerobic conditions. This temperature is the optimal
24
25 212 temperature for amoebae and mimics the environmental conditions found in broiler houses and
26
27 213 natural environments. The wells then were washed three times with 2 ml of amoeba buffer to
28
29 214 remove extracellular bacteria, followed by the addition of 2 ml of fresh amoeba buffer containing
30
31 215 $350 \mu\text{g ml}^{-1}$ gentamicin (BioBasics) and incubated at 25°C for 1 h to kill remaining extra-amoeba
32
33 216 bacteria. The concentration of gentamicin employed was chosen for maximal killing effect
34
35 217 without affecting the amoeba cell monolayer as previously described (Bui *et al.*, 2011). One
36
37 218 hundred microlitres of 10^7 CFU ml^{-1} of *E. coli* DH5 α cells that had been heat-killed by exposure
38
39 219 to 90°C for 20 min were added to each well as a food source to avoid stress by starvation of
40
41 220 amoebae. The infected amoeba monolayers were processed at 0, 5 and 24 h after gentamicin
42
43 221 treatment. Processing at each time point was as follows. The buffer was carefully aspirated and
44
45 222 the wells were washed three times with 2 ml of amoeba buffer to remove the antibiotic. Then, the
46
47 223 number of amoebae in the wells was counted directly using an inverted light microscope.
48
49 224 Aliquots of 100 μl of the last wash step were sampled to determine the number of remaining
50
51
52
53
54
55
56
57
58
59
60

1
2
3 225 extracellular bacteria after gentamicin treatment. Five hundred microlitres of sterile PBS
4
5 226 containing 95% Triton X-100 (final concentration 0.3 % [v/v] in PBS) were added to lyse
6
7
8 227 infected amoebae. The extent of lysis was monitored for 10-15 min under the inverted light
9
10 228 microscope until approximately 100% of the trophozoites were lysed. Aliquots of 100 μ l of 10-
11
12 229 fold serial dilutions of the lysate were taken for bacterial counts to determine the number of
13
14 230 intracellular bacteria. Wells to be processed at a later time were washed with amoeba buffer, and
15
16 231 heat-killed *E. coli* cells were added as indicated above. All experiments were carried out in
17
18 232 triplicate.

22 233 **Phagocytosis and intra-amoeba killing inhibitor study**

24
25 234 Co-cultivation was established as described above with the following modifications.
26
27 235 Amoeba monolayers were pre-treated for 1 h in amoeba buffer with cytochalasin D (Sigma) to
28
29 236 inhibit actin polymerization and wortmannin (Sigma) to inhibit phosphoinositide 3-kinase at the
30
31 237 concentrations of 50 μ M and 1 μ M, respectively prior to co-culture with stressed and non-
32
33 238 stressed *C. jejuni* cells. The infected amoeba monolayers were processed immediately after
34
35 239 gentamicin treatment (t = 0 h) to determine the invasion of *C. jejuni*. Likewise, to determine if
36
37 240 phagosomal acidification and phago-lysosome fusion was involved in intracellular killing of *C.*
38
39 241 *jejuni* by *A. castellanii*, the amoeba monolayers were pre-treated for 1 h in amoeba buffer with
40
41 242 monensin and suramin (Sigma) at the concentrations of 5 μ M and 300 μ g mL⁻¹, respectively
42
43 243 prior to co-culture with non-stressed *C. jejuni* cells. The infected amoeba monolayers were
44
45 244 processed at 0 and 5 h after gentamicin treatment to determine the effect of the inhibitors on the
46
47 245 intracellular survival rates of *C. jejuni* within *A. castellanii*.

48
49 246 Prior to use, these inhibitors were diluted in culture medium (amoeba buffer) without
50
51 247 antibiotic. The concentration of each inhibitor employed was chosen for maximal inhibitory

++

1
2
3 248 effect without affecting the amoeba cell monolayer which was verified by phase contrast
4
5
6 249 microscopy. To confirm that the inhibitors did not inhibit bacterial growth, bacterial cells were
7
8 250 inoculated in amoeba buffer with or without inhibitors at 25°C in aerobic conditions for various
9
10 251 times and the viable bacteria in both groups were compared by counting.

12 252 **Confocal laser scanning microscopy (CLSM)**

15 253 To visualize intracellular bacteria, amoebae were co-cultured with stressed and non-
16
17 254 stressed *C. jejuni* in 6-well tissue culture plates as described previously, with the exception that
18
19 255 the amoebae were overlaid on sterile 22-mm-diameter round glass coverslips (VWR, USA).
20
21 256 Before infection, stressed and non-stressed *C. jejuni* cells were incubated at 37°C in amoeba
22
23 257 buffer in microaerophilic conditions for 45 min with a final concentration of 10 µg mL⁻¹ of
24
25 258 Celltracker™ Red CMTPX (Invitrogen, Burlington, ON, Canada) according to the
26
27 259 manufacturer's recommendations. In order to label acidic vacuoles, infected *A. castellanii*
28
29 260 monolayers were stained with 10 µM LysoSensor™ Green DND-189 (Invitrogen, Burlington,
30
31 261 ON, Canada) for 30 min before each time point according to the manufacturer's
32
33 262 recommendations. All assays were carried out in the dark to avoid photobleaching of labelled
34
35 263 cells. Cells were dried on poly-L-lysine slides before visualization under a confocal laser
36
37 264 scanning microscope (Zeiss Axiovert 200M, Carl Zeiss vision, Germany). To study the effect of
38
39 265 acidification of Campylobacter-containing vacuoles and phago-lysosome fusion on bacterial
40
41 266 killing, the procedures were followed as described above but the amoebae were pre-treated with
42
43 267 suramin or monensin for 1 h. Confocal microscopy was done at the gap junction facility of the
44
45 268 University of Western Ontario, Canada.

53 269 **Transmission electron microscopy (TEM)**

1
2
3 270 The localization of *C. jejuni* inside *A. castellanii* was analysed by TEM. Infected
4
5
6 271 amoebae were washed three times with amoeba buffer to remove the extracellular bacteria and
7
8 272 incubated in fresh amoeba buffer containing gentamicin with a final concentration of 350 $\mu\text{g ml}^{-1}$
9
10 273 for 1 h. The monolayers were washed three times with 1x PBS pH 7.4 and re-suspended in
11
12 274 antibiotic-free amoeba buffer. The infected amoeba cells were centrifuged for 10 min at 300 *g*.
13
14
15 275 Each pellet of infected amoebae was fixed in 2.5% glutaraldehyde in 0.1 M sodium cacodylate
16
17 276 buffer pH 7.3, with 0.1 M sucrose and 3 mM CaCl_2 , for 30 min at room temperature. The
18
19
20 277 samples were then washed in sodium cacodylate buffer and post-fixed in 2% osmium tetroxide in
21
22 278 the same buffer for 1 h. The samples were pellet by centrifugation, dehydrated according to
23
24 279 standard procedures and embedded in Epon. Ultrathin sections were collected on one-hole
25
26
27 280 copper grids, and stained with uranyl acetate and lead citrate. Sections were examined with a
28
29 281 Philips CM 100 TEM operated at 80 kV accelerating tension. Images were recorded with an
30
31 282 OSIS Veleta 2kx2k CCD camera and the Analysis ITEM software package. TEM was done at
32
33
34 283 the Core Facility for Integrated Microscopy (CFIM) at University of Copenhagen, Denmark.

35 36 284 **Statistical analysis**

37
38
39 285 A Student's *t*-test was used to compare the groups and controls. *P*-values of <0.05 were
40
41 286 considered statistically significant.

42 43 287 **Results**

44 45 288 **The effect of environmental stresses on the survival of *C. jejuni***

46
47
48 289 As shown in Fig. 1, exposure to low nutrient, heat and osmotic stresses strongly
49
50 290 decreased the survival of *C. jejuni*. The heat and osmotic stresses reduced the survival of *C.*
51
52 291 *jejuni* the most. In contrast, exposure of *C. jejuni* to hydrogen peroxide (oxidative stress) for 15
53
54
55 292 min did not affect the survival of *C. jejuni*.

293 **Transcription of virulence genes in *C. jejuni* under environmental stresses**

294 Three virulence-related genes, *htrA*, *dnaJ* and *ciaB*, were chosen as reporters to monitor
295 if transcriptional regulation occurred after exposure of *C. jejuni* to various stresses. The CiaB
296 protein enhances invasion of eukaryotic cells (Konkel *et al.*, 1999; Li *et al.*, 2008). HtrA
297 degrades and prevents aggregation of periplasmic proteins that misfold during stress (Laskowska
298 *et al.*, 1996; Li *et al.*, 1996). DnaJ aids in protein folding and plays a role in *C. jejuni*
299 thermotolerance and in chicken colonization (Konkel *et al.*, 1998; Ziprin *et al.*, 2001). A prior
300 study reported that transcription of *dnaJ* is up-regulated upon temperature stress (Stintzi, 2003).
301 Quantitative real-time RT-PCR analyses showed that all three genes were transcribed
302 constitutively in bacteria grown in optimal conditions, with expression folds of 23.8, 18.2, and
303 14.0 for *htrA*, *dnaJ*, and *ciaB*, respectively, relatively to the *16S rRNA* internal control (data not
304 shown). Transcriptional analyses were performed to examine whether the stresses tested above
305 affected the expression of the selected virulence-associated genes (*htrA*, *dnaJ* and *ciaB*). The *16S*
306 *rRNA* gene was again used as the internal control, and the fold change of gene transcription
307 induced by stress exposure was determined relative to the bacteria in the absence of any stress.
308 As shown in Fig. 2, the transcription of *dnaJ* and *ciaB* was not affected by heat stress and only
309 slightly altered after exposure to the other stresses. A modest up-regulation was observed under
310 oxidative stress (~ 2.7 and 2 fold for *ciaB* and *dnaJ*, respectively, $p < 0.05$) while a modest down-
311 regulation (~2.8 to 3.2 fold, $p < 0.01$) was observed for both genes under low nutrient or osmotic
312 stresses. The transcription of *htrA* was moderately up-regulated under oxidative stress and
313 slightly down-regulated under low nutrient stress but the change was not statistically significant
314 ($p > 0.05$). In contrast, transcription of *htrA* was up-regulated 2.5 fold under heat stress ($p = 0.03$)
315 and down-regulated ~ 10 fold under osmotic stress ($p < 0.01$).

1
2
3 316 Overall, the results of the qRT-PCR experiments showed that the transcription of the
4
5 317 three virulence-associated genes of *C. jejuni* was only slightly up-regulated under heat and
6
7
8 318 oxidative stresses but tended to be down-regulated under low nutrient and osmotic stresses, with
9
10 319 *htrA* showing the most down-regulation in response to osmotic stress.
11
12

13 320 **Uptake and intracellular survival of stressed *C. jejuni* within *A. castellanii***

14
15
16
17 321 We showed above that stress exposure has potential to alter the transcription of virulence-
18
19 322 associated genes. This may in turn affect subsequent interactions with host cells, including
20
21 323 phagocytosis and the ability of *C. jejuni* to survive in host cells after internalization. Since the
22
23
24 324 transcriptional variations obtained for the three genes tested were relatively small, we tested the
25
26 325 importance of one of them (*htrA*) for the interaction of *C. jejuni* with amoeba using the *htrA*
27
28 326 mutant that was previously described (Brondsted *et al.*, 2005). Both bacterial uptake and
29
30
31 327 intracellular survival were measured. The intracellular bacteria were enumerated using the
32
33 328 gentamicin protection assay optimized for amoebae that we described previously (Bui *et al.*,
34
35
36 329 2011). Immediately after gentamicin treatment (0 h post gentamicin treatment), no significant
37
38 330 difference was observed in the number of internalized bacteria recovered with the wild-type and
39
40 331 the *htrA* mutant strain (Fig. 3 A). Consistently with our prior study (Bui *et al.*, 2011), the number
41
42
43 332 of live internalized bacteria decreased drastically at 5 h post gentamicin treatment. This decrease
44
45 333 in intracellular survival was significantly bigger in the *htrA* mutant than in the wild-type strain
46
47 334 (Fig. 3A). These data show that *htrA* is important for intra-amoebae survival but not for uptake.
48
49

50
51 335 To examine the impact of pre-exposure to stressful environments on the degree of
52
53 336 phagocytosis by amoebae and on the intracellular survival of *C. jejuni* in amoebae, stressed and
54
55 337 non-stressed *C. jejuni* cells were co-cultured with *A. castellanii*. Immediately after gentamicin
56
57
58
59
60

1
2
3 338 treatment (0 h post gentamicin treatment), approximately 0.18% of the original non-stressed
4
5 339 bacterial inoculum was recovered as internalized bacteria, but only ~ 0.06 and 0.14% of the
6
7
8 340 original bacterial inoculum were observed with *C. jejuni* pre-exposed to low nutrient and osmotic
9
10 341 stresses, respectively (Fig. 3 B). No statistically significant differences were obtained with *C.*
11
12 342 *jejuni* pre-exposed to heat and oxidative stresses compared with non-stressed bacteria. At 5 h
13
14 343 post gentamicin treatment, consistently with our prior study (Bui *et al.*, 2011), only 0.06% of the
15
16 344 original inoculum was obtained for non-stressed *C. jejuni*. Pre-exposure of bacteria to heat,
17
18 345 starvation or osmotic stresses exacerbated the bacterial susceptibility to intracellular killing,
19
20 346 since a significant decline of the number of surviving bacteria was observed upon pre-exposure
21
22 347 to these stresses 5 h post-gentamicin treatment (Fig. 3 B). At 24 h post gentamicin treatment,
23
24 348 while a few internalized bacteria were observed with non-stressed bacteria, none were recovered
25
26 349 after exposure to heat, starvation or osmotic stress. In contrast to the effects described above for
27
28 350 heat, starvation and osmotic stresses, pre-exposure to oxidative stress had no impact on
29
30 351 internalization or intracellular survival of *C. jejuni* under the conditions and time frame studied.
31
32 352 Overall, these results indicate that *C. jejuni* rapidly loses its viability during the course of its
33
34 353 intracellular stage and that exposure of *C. jejuni* to environmental stresses other than oxidative
35
36 354 stress prior to interactions with amoebae not only did not “prepare” the bacteria to fight off the
37
38 355 amoebae killing machinery, but also strongly compromised their ability to survive within the
39
40 356 amoebae.
41
42
43
44
45
46
47
48

49 357 A more detailed observation of *C. jejuni* cells internalized within the amoebae was
50
51 358 carried out by confocal laser scanning microscopy (CLSM). In the absence of any stress, live *C.*
52
53 359 *jejuni* cells were detected by CellTracker Red staining inside the trophozoites immediately after
54
55 360 gentamicin treatment (Fig. 4 A, B). The intracellular bacteria were distributed as clusters within

1
2
3 361 acidic vacuoles as observed by the simultaneous staining of acidic vacuoles by LysoSensor
4
5 362 Green DND-189 (Fig. 4 C, D). This is consistent with our previous observations (Bui *et al.*,
6
7
8 363 2011). Pre-exposure of bacteria to low-nutrient, heat, osmotic or oxidative stress did not
9
10 364 qualitatively alter the subcellular location of internalized bacteria, as all were also recovered in
11
12 365 acidic vacuoles (Fig. 4 E to T).

13
14
15
16 366 Alongside the viable count assay for the quantification of intracellular bacteria and
17
18 367 CLSM analyses reported above, TEM was also used to examine more precisely the effect of heat
19
20 368 stress on intracellular location of *C. jejuni* within *A. castellanii*. The heat stress was selected for
21
22 369 TEM studies since we have shown above that heat stress decreased intracellular survival of *C.*
23
24 370 *jejuni*, but it did not affect uptake. Therefore this heat stress allowed visualization of numerous
25
26 371 internalized bacteria at early time points. As shown in Fig. 5, sections of infected *A. castellanii*
27
28 372 cells obtained right after gentamicin treatment showed *C. jejuni* confined to tight vacuoles within
29
30 373 the amoebae, whether they had been heat-stressed or not prior to co-culture with amoebae (Fig. 5
31
32 374 A, C). At 5 h post gentamicin treatment, fewer internalized bacteria could be seen inside the
33
34 375 amoeba vacuoles, the bacterial cells were partially degraded (white arrows Fig. 5 E, F), and heat
35
36 376 stress significantly reduced the number of bacteria present in the vacuoles (Fig. 5 D, F)
37
38 377 compared with control bacteria (Fig. 5 B, E). This corroborated the survival and CLSM data
39
40 378 described above.

41 42 379 **Mechanism involved in the phagocytosis of *C. jejuni* by *A. castellanii***

43
44
45
46
47
48 380 To determine if actin microfilaments are involved in the uptake of *C. jejuni* by *A.*
49
50 381 *castellanii* as widely reported for uptake by intestinal cells and macrophages (Wassenaar *et al.*,
51
52 382 1997; Biswas *et al.*, 2000), cytochalasin D was used for inhibition assays. Cytochalasin D is a

1
2
3 383 specific inhibitor of actin microfilament polymerization and has been used extensively to study
4
5
6 384 actin polymerization-dependent processes in eukaryotic cells and amoebae (King *et al.*, 1991;
7
8 385 Biswas *et al.*, 2000; Alsam *et al.*, 2005; Akya *et al.*, 2009). Also, to evaluate the potential role of
9
10 386 the phosphoinositide 3-kinase (PI 3-kinase) in the signaling pathways that mediate actin
11
12 387 polymerization and phagocytosis of *C. jejuni*, the PI 3-kinase inhibitor wortmannin was used. *A.*
13
14 388 *castellanii* cells were pre-treated with cytochalasin D or wortmannin for 1 h prior to co-culture
15
16 389 with stressed and non-stressed *C. jejuni*. The two inhibitors remained present throughout the
17
18 390 experiment. As seen by enumeration immediately after gentamicin treatment, the pre-treatment
19
20 391 of amoebae with wortmannin had no effect on the uptake of *C. jejuni* by *A. castellanii*, whether
21
22 392 the bacteria had been pre-exposed to stress or not (Fig. 6). Therefore PI 3-kinase does not seem
23
24 393 to play a major role in the signal transduction events that lead to internalization of *C. jejuni* by
25
26 394 amoeba. In contrast, pre-treatment of amoeba with cytochalasin D resulted in a significant
27
28 395 decline in the amount of recovered intra-amoeba bacteria ($p < 0.01$). This decrease was
29
30 396 exacerbated by pre-exposure of the bacteria to starvation but not to heat, osmotic or oxidative
31
32 397 stress.
33
34
35
36
37
38

39 398 The inhibition of uptake of *C. jejuni* by *A. castellanii* by cytochalasin D and lack of effect
40
41 399 of wortmannin indicate that this bacterium uses a distinct strategy for phagocytosis which
42
43 400 involves recruiting actin for internalization in the absence of PI 3-kinase-mediated signal
44
45 401 transduction. This is in contrast to what was observed for example for uptake of *L.*
46
47 402 *monocytogenes* by amoeba (Akya *et al.*, 2009).
48
49
50
51

52 403 **Mechanism involved in intracellular killing of *C. jejuni* by *A. castellanii***
53
54
55
56
57
58
59
60

1
2
3 404 To better elucidate the intracellular killing mechanism of *C. jejuni* by *A. castellanii*, we
4
5
6 405 examined the impact of phago-lysosome fusion and role of phagosomal acidification using two
7
8 406 different inhibitors: suramin and monensin. Monensin blocks phagosomal acidification, which
9
10
11 407 affects eukaryotic and amoeba receptor recycling to the cell surface and can induce changes in
12
13 408 engulfed bacteria that are necessary for intracellular survival (Oelschlaeger *et al.*, 1993; Biswas
14
15 409 *et al.*, 2000; Akya *et al.*, 2009). Suramin is a polybasic anion that binds strongly to plasma
16
17 410 proteins and enters cells by endocytosis. It interferes with phago-lysosome fusion in
18
19
20 411 macrophages (Pesanti, 1978) and *A. polyphaga* (Akya *et al.*, 2009). *C. jejuni* was co-cultured
21
22 412 with control amoeba or amoeba that had been pre-treated with suramin or monensin.
23
24
25 413 Immediately after gentamicin treatment, no statistically significant differences in the number of
26
27 414 internalized bacteria were observed between the pre-treated and control amoebae (Fig. 7). This
28
29 415 indicates that the steps of phago-lysosome maturation targeted by the inhibitors do not have any
30
31 416 effects on the uptake per se, as expected. While phago-lysosome maturation is widely accepted
32
33
34 417 as an essential mechanism of intracellular killing, and while internalized *C. jejuni* was shown
35
36 418 above to be confined to acidic vacuoles in untreated amoebae, no effect of the suramin and
37
38
39 419 monensin inhibitors was observed on the mean counts of surviving bacteria 5 h post gentamicin
40
41 420 treatment (Fig. 7). These observations could suggest that phago-lysosome maturation is not the
42
43
44 421 primary factor for intra-amoeba killing of *C. jejuni* by *A. castellanii*, or that the inhibitors only
45
46 422 caused a delay in bacterial killing as opposed to the anticipated complete blockage. To determine
47
48 423 which of the two options was right, microscopy examinations were performed. They showed that
49
50 424 some bacteria were present in non acidified vacuoles in suramin-treated cells, as expected, but
51
52
53 425 that other bacteria were located in acidic vacuoles (Fig. 8 E-H). Therefore, the blockade of
54
55 426 vacuole acidification by suramin was not complete, and may only have been slowed down so that

1
2
3 427 acidification of the bacteria-containing vacuoles could still occur eventually and contribute to
4
5
6 428 bacterial killing. Likewise, microscopic examination showed that fusion between acidic vesicles
7
8 429 and bacteria-containing vacuoles was not complete in monensin-treated cells, although both
9
10 430 acidic and bacteria-containing vacuoles were located in very close proximity (Fig. 8 A-D). It is
11
12 431 possible that a simple delay in the kinetics of the fusion process occurred as opposed to full
13
14
15 432 blockade. This may explain why phago-lysosome fusion still contributed to the killing of *C.*
16
17 433 *jejuni* by *A. castellanii*.

20 434 **Discussion**

21 435 **Effect of pre-exposure to stress on extracellular survival**

22
23
24
25
26 436 Although *C. jejuni* has strict growth requirements (van Vliet *et al.*, 1999; Murphy *et al.*,
27
28 437 2006; Sagarzazu *et al.*, 2010), it has developed mechanisms for survival in diverse environments,
29
30 438 both inside and outside the host, where it is subjected to various stresses (Murphy *et al.*, 2006;
31
32
33 439 Young *et al.*, 2007). Starvation has been shown to be the most powerful stress factor, which
34
35 440 affects *C. jejuni* culturability and viability (Cappelier *et al.*, 1999; Mihaljevic *et al.*, 2007). In
36
37 441 addition, osmotic and heat stresses also reduce survival of *C. jejuni* (Reezal *et al.*, 1998; Candon
38
39 442 *et al.*, 2007; Jackson *et al.*, 2009; Pogačar *et al.*, 2009a; Gangaiah *et al.*, 2010). Consistent with
40
41
42 443 prior studies, our data showed that heat, low nutrient and osmotic stresses all significantly
43
44 444 reduced the extracellular survival of *C. jejuni* while oxidative stress had no effect (Fig. 1). The
45
46 445 observed decline in viability could be due to the fact that these stresses induced *C. jejuni* to turn
47
48 446 into coccoid cells, which is correlated with decreased culturability. Previous studies have also
49
50
51 447 shown that *C. jejuni* cells became coccoid cells quickly after encountering heat and starvation
52
53
54 448 stresses (Klančnik *et al.*, 2006; Klančnik *et al.*, 2009).

1
2
3 449 The fact that pre-exposure to oxidative stress did not affect the survival of *C. jejuni* in
4
5
6 450 comparison with non-stressed cells could be because the hydrogen peroxide concentration (10
7
8 451 mM) and the incubation time (15 min) applied in this study were not sufficient to damage the
9
10
11 452 bacterial cells or to trigger a transition into the coccoid form. Furthermore, in order to survive
12
13 453 under moderate oxidative stress, *C. jejuni* possesses mechanisms which can remove or convert
14
15 454 reactive oxygen species, such as superoxide, peroxides and hydroxyl radicals before these
16
17 455 products can cause significant damage to the DNA, proteins and lipids (van Vliet *et al.*, 1999;
18
19
20 456 Palyada *et al.*, 2009). While these systems are not as developed as those observed in aerobic
21
22 457 bacteria, their existence could explain that the limited oxidative stress imposed had no effect on
23
24
25 458 the extracellular survival of *C. jejuni*.

26 27 459 **Effect of pre-exposure to stress on the transcription of *ciaB*, *htrA* and *dnaJ***

28
29 460 The transcription of virulence genes is modulated by different stresses in many bacterial
30
31
32 461 pathogens (Mekalanos, 1992; Abee and Wouters, 1999; Allen *et al.*, 2008). As a microaerophilic
33
34 462 bacterium, *C. jejuni* must adapt to oxidative stress during transmission and infection (Jackson *et*
35
36 463 *al.*, 2009) and, consistent with this idea, our qRT-PCR data showed that oxidative stress affected
37
38
39 464 the transcription of the *ciaB* gene, with a 2.7 fold increase. A previous study reported that culture
40
41 465 with the bile acid deoxycholate “primes” *C. jejuni* to invade epithelial cells by stimulating the
42
43
44 466 synthesis of Cia proteins (Malik-Kale *et al.*, 2008). Thus, the increase in *ciaB* transcription
45
46 467 observed in response to oxidative stress could indicate that oxidative stress also “primes” *C.*
47
48 468 *jejuni* for invasion of epithelial cells by ensuring that it would harbor pre-synthesized Cia
49
50
51 469 proteins. Likewise, transcriptional regulation of *ciaB* was observed under low nutrient and
52
53 470 osmotic stresses, but in contrast to oxidative stress, these stresses triggered slight decreases (2.8
54
55
56 471 and 3.2 fold) of transcription. This is in agreement with a previous study that revealed that the

1
2
3 472 transcription of *ciaB* decreased under starvation stress (Ma *et al.*, 2009) and this indicates that no
4
5
6 473 CiaB-based priming is occurring under such stresses.
7

8
9 474 HtrA plays an important role in stress tolerance and survival of Gram-negative bacteria as
10
11 475 it degrades periplasmic proteins that misfold under stress (Laskowska *et al.*, 1996; Li *et al.*,
12
13 476 1996). Recently, several studies have suggested that HtrA is important for *C. jejuni* virulence
14
15
16 477 (Brondsted *et al.*, 2005; Champion *et al.*, 2010; Baek *et al.*, 2011a; Baek *et al.*, 2011b) and we
17
18 478 showed that HtrA is important for intra-amoeba survival of *C. jejuni* by using the *htrA* mutant.
19
20 479 However, limited data are available regarding *htrA* transcriptional regulation during
21
22
23 480 environmental stress in *C. jejuni*. Our qRT-PCR results showed that heat, oxidative and low
24
25 481 nutrient stresses only slightly altered *htrA* transcription. Because the basal level of transcription
26
27 482 of *htrA* is rather high, one may speculate that the levels of HtrA protein are sufficient to
28
29 483 regenerate a proper periplasmic environment via degradation of misfolded proteins and that the
30
31
32 484 limited variations in transcription observed under these stresses may not significantly affect the
33
34 485 overall levels of the HtrA protein. Surprisingly though, osmotic stress heavily repressed the
35
36 486 transcription of *htrA* (~ 10 fold). Such down-regulation is rather counter-intuitive since hyper
37
38 487 osmotic stress likely causes aggregation of proteins upon loss of cellular fluids by osmosis. Other
39
40 488 stress-response mechanisms may be up-regulated in such circumstances to counter-act the down-
41
42 489 regulation of transcription of *htrA*. Their identity is up for debate since *C. jejuni* does not appear
43
44
45 490 to have the traditional CpX and RseA/B stress response systems (Brondsted *et al.*, 2005).
46
47
48

49
50 491 While the DnaJ *chaperone* plays a role in *C. jejuni* thermo-tolerance and in chicken
51
52 492 colonization (Konkel *et al.*, 1998; Ziprin *et al.*, 2001), and *dnaJ* transcription was shown
53
54 493 previously to be enhanced under heat stress (Stintzi, 2003), we did not observe any effect of heat
55
56
57
58
59
60

1
2
3 494 stress on the transcription of *dnaJ*. This discrepancy is likely due to the very different heat
4
5
6 495 stresses applied.
7

8
9 496 Altogether, although the levels of transcriptional regulation were generally low and
10
11 497 varied between the three virulence-associated genes tested, similar trends were observed: up-
12
13 498 regulations upon oxidative and heat stress versus down-regulation upon low nutrient and osmotic
14
15 499 stresses. The low levels of regulation indicate that other stress-response mechanisms are more
16
17 500 important to fight low nutrient and osmotic stresses than the three genes investigated. Large scale
18
19 501 microarray studies should help elucidate which systems are involved and their relative
20
21 502 contributions in these regulatory aspects. Alternatively, the data could indicate that applying each
22
23 503 stress individually did not reflect the complex environmental triggers that *C. jejuni* is exposed to.
24
25 504 It would be interesting to determine the cumulative effects of multiple stresses, with the caveat
26
27 505 that correlation of the effects to specific molecular mechanisms may be very difficult to establish
28
29 506 in this kind of study.
30
31
32
33
34
35

36 507 **Effect of pre-exposure to stress on uptake of *C. jejuni* by amoeba**

37
38 508 Since the modulation of virulence genes in response to stresses is a common phenomenon
39
40 509 of pathogenic bacteria, it is important to get insight into the influence of these conditions on the
41
42 510 interaction of bacteria with other organisms, such as amoebae, which exist in similar habitats.
43
44 511 Beyond the data presented herein, no data are currently available to determine whether pre-
45
46 512 exposure to environmental stresses might enhance this bacterium's ability to escape uptake or
47
48 513 intracellular killing by amoeba. Our data showed that low nutrient and osmotic stresses were the
49
50 514 strongest factors which significantly affected not only extracellular survival (Fig. 1, decreased
51
52 515 survival) and transcription of three virulence-associated genes of *C. jejuni* (Fig. 2), but also
53
54
55
56
57
58
59
60

1
2
3 516 reduced the uptake of this bacterium within *A. castellanii* (Fig. 3). Our findings are consistent
4
5
6 517 with previous studies that reported that starvation strongly affected *C. jejuni* invasion in Caco-2
7
8 518 and macrophages (Klančnik *et al.*, 2009; Pogačar *et al.*, 2009b).
9

10
11 519 In contrast, our data showed that heat and oxidative stresses did not affect the uptake of
12
13 520 *C. jejuni* by the amoebae. These findings differ from previous studies that reported that pre-
14
15 521 exposure of *C. jejuni* to oxidative stress increased the invasion of *C. jejuni* in these cell types
16
17 522 (Mihaljevic *et al.*, 2007; Pogačar *et al.*, 2009a), and that heat stress significantly reduced the
18
19 523 invasion of *C. jejuni* in Caco-2 and macrophages. The discrepancy between our study and others
20
21 524 is likely due to cell line-specific mechanisms of uptake and killing, and variations in the nature
22
23 525 and abundance of appropriate eukaryotic receptors (Oelschlaeger *et al.*, 1993). Discrepancies
24
25 526 could also be due to the experimental set up whereby the longer time of pre-exposure of *C. jejuni*
26
27 527 to high temperature used in this study might affect the transcription of a wider repertoire of
28
29 528 virulence-associated genes and may promote the uptake or phagocytosis of this bacterium by the
30
31 529 amoebae.
32
33
34
35

36 530 **Correlation between the effects of stress on transcription of virulence-associated gene and**
37
38 531 **the effects of stress on uptake by amoeba**
39

40
41 532 Previous studies have shown that *ciaB*, *htrA*, and *dnaJ* play important roles in the
42
43 533 invasion of *C. jejuni* (Konkel *et al.*, 1998; Konkel *et al.*, 1999; Ziprin *et al.*, 2001; Brondsted *et*
44
45 534 *al.*, 2005; Li *et al.*, 2008; Baek *et al.*, 2011a), but most of these studies involve epithelial cells
46
47 535 which have little to no phagocytic abilities. In these cell types, uptake is mostly due to receptor-
48
49 536 mediated endocytosis, and surface expression of appropriate ligands on the surface of *C. jejuni* is
50
51 537 paramount for successful uptake. In contrast, phagocytic uptake in amoeba is not receptor
52
53 538 mediated as corroborated by the fact that amoeba can phagocytose latex beads (Avery *et al.*,
54
55
56
57
58
59
60

1
2
3 539 1995). Consequently, the effect of *ciaB*, *htrA* and *dnaJ* on interaction (phagocytosis and killing)
4
5
6 540 with amoeba remained to be established.

7
8 541 Overall, our data showed good correlation between the down-regulation of transcription
9
10 542 of the three genes investigated (although overall small) and reduced uptake by amoeba only for
11
12 543 the starvation stress. These data may also reflect the fact that the starved bacteria are weak and
13
14
15 544 fragile so that the kinetics of killing are altered. In the case of starvation stress, this could result
16
17 545 from the fact that starved cells do not have the resources necessary to alter their patterns of
18
19
20 546 protein expression in response to further stress (amoeba killing machinery). A faster intracellular
21
22 547 killing occurring during the 1 h that it takes to proceed with the gentamicin treatment could
23
24
25 548 explain the apparent lower uptake values.

26
27 549 Globally, for the other 3 stresses tested, we did not observe any clear correlation between
28
29 550 gene transcription and uptake by amoeba. These data could indicate that the genes may rather
30
31 551 play an important role for the intracellular survival of the bacteria rather than for uptake, which
32
33
34 552 we demonstrated with the available *htrA* mutant. Additionally, as explained above for HtrA, this
35
36 553 could relate to the high levels of constitutive transcription of all 3 genes observed under normal
37
38
39 554 growth conditions and to the overall very small transcriptional variations.

40 41 555 **Effect of pre-exposure to stress on intracellular survival in amoeba**

42
43 556 Prior studies of the intra-amoeba survival of *C. jejuni* were performed using bacteria
44
45
46 557 grown in optimal culture conditions (temperature, media and atmospheric conditions), and not
47
48 558 adapted to stressful conditions (Axelsson-Olsson *et al.*, 2005; Snelling *et al.*, 2005; Axelsson-
49
50 559 Olsson *et al.*, 2010; Baré *et al.*, 2010; Bui *et al.*, 2011). Herein, we investigated if pre-exposure
51
52
53 560 to stressful conditions may prime the bacteria for resistance to further intracellular stress.
54
55 561 Contrary to our expectations, the bacteria that had been pre-exposed to low nutrient, heat and

1
2
3 562 osmotic stress were more sensitive to intracellular killing than control *C. jejuni* as seen at 5 h
4
5
6 563 post gentamicin treatment. These findings are consistent with previous data showing that pre-
7
8 564 exposure of *C. jejuni* to environmental stresses (except oxidative stress) did not promote its
9
10 565 survival within Caco-2 cells or macrophages (Mihaljevic *et al.*, 2007; Pogačar *et al.*, 2009a).
11
12 566 Heat-stressed bacteria were taken up at non-stressed levels but did not survive any better than
13
14 567 starved or osmotic-stressed bacteria that had decreased uptake. This suggests that uptake and
15
16 568 intracellular survival rely on distinct properties of the bacteria and that the impact of each stress
17
18 569 on either step (uptake or survival) is likely dependent on the repertoire of genes targeted by the
19
20 570 transcriptional regulation response elicited by each stress.
21
22
23

24 571 **Does pre-exposure of *C. jejuni* to stress affect the mechanism of bacteria uptake by**
25
26 572 **amoeba?**
27
28

29 573 It has been reported that the interaction of invasive enteric bacterial pathogens with
30
31 574 amoebae triggers amoeba signal transduction pathways which result in bacterial internalization
32
33 575 (Levchenko and Iglesias, 2002; Akya *et al.*, 2009). Although several studies have shown the
34
35 576 involvement of eukaryotic signaling in invasion of host cells by *C. jejuni* (Biswas *et al.*, 2000;
36
37 577 Hu *et al.*, 2006), no data are available regarding how this bacterium enters amoebae. In this
38
39 578 study, the mechanism involved in the phagocytosis of *C. jejuni* by *A. castellanii* was investigated
40
41 579 using two inhibitors, wortmannin and cytochalasin D. While the phosphoinositide 3-kinase
42
43 580 inhibitor wortmannin is known to reduce *C. jejuni* uptake in epithelial cells (Wooldridge *et al.*,
44
45 581 1996; Biswas *et al.*, 2000; Hu *et al.*, 2006), it did not inhibit the phagocytosis of *C. jejuni* by *A.*
46
47 582 *castellanii* (Fig. 6). In contrast, the microfilament polymerization inhibitor cytochalasin D
48
49 583 (Cooper, 1987; Monteville *et al.*, 2003) inhibited the invasion of *C. jejuni* in both cell types:
50
51 584 human epithelial cells (Biswas *et al.*, 2000; Hu *et al.*, 2006) and amoeba (Fig. 6). This suggests
52
53
54
55
56
57
58
59
60

1
2
3 585 that the phagocytosis of *C. jejuni* by *A. castellanii* may involve general signaling pathways that
4
5
6 586 regulate actin polymerization. These findings are consistent with previous reports that this
7
8 587 inhibitor reduced uptake of *L. pneumophila* and *L. monocytogenes* by various *Acanthamoebae*
9
10 588 (Moffat and Tompkins, 1992; Akya *et al.*, 2009) and indicate that the mechanisms involved are
11
12 589 neither amoeba- nor bacteria- specific. Importantly, the decreased ability of amoeba to uptake *C.*
13
14 590 *jejuni* upon was specifically exacerbated by pre-exposure of the bacteria to starvation but not to
15
16 591 any of the other three stresses tested. As discussed above, this may be a mere reflection of their
17
18 592 higher susceptibility to intracellular killing which may occur during the 1 h gentamicin
19
20 593 treatment.

21
22
23
24 594 Phagosomal acidification has a key role in degradation of phagocytosed bacterial cells by
25
26 595 macrophages and amoebae (Styrt and Klempner, 1988; Downey *et al.*, 1999; Watson and Galán,
27
28 596 2008; Akya *et al.*, 2009). Consistently with our prior study (Bui *et al.*, 2011), our CSLM and
29
30 597 TEM data clearly showed that intracellular *C. jejuni* cells were located in acidified vacuoles,
31
32 598 suggesting that *C. jejuni* did not escape phago-lysosome fusion. To get further insight into how
33
34 599 *A. castellanii* killed intracellular *C. jejuni*, inhibitors of vacuolar acidification and phago-
35
36 600 lysosome fusion were used: monensin and suramin (Weidner and Sibley, 1985; Oelschlaeger *et*
37
38 601 *al.*, 1993; Akya *et al.*, 2009). Our data showed that neither inhibitor had any effect on
39
40 602 intracellular survival of *C. jejuni*. The findings about monensin are in agreement with a previous
41
42 603 study that showed that monensin only slightly decreased intra-amoeba killing of *L.*
43
44 604 *monocytogenes* by *A. polyphaga*, but the data about suramin contrast with an earlier report that
45
46 605 suramin pre-treatment significant reduced the rate of intra-amoeba killing (Akya *et al.*, 2009).
47
48 606 Although in our study, phago-lysosome fusion and vacuole acidification were not totally
49
50 607 inhibited but were only delayed or slowed down, one would expect a significant impact on
51
52
53
54
55
56
57
58
59
60

1
2
3 608 intracellular bacterial survival if these processes were the only mechanisms of intracellular
4
5 609 bacterial killing. The lack of effect suggests that novel mechanisms of intracellular killing of *C.*
6
7
8 610 *jejuni* and potentially other pathogenic bacteria by *A. castellanii* remain to be uncovered.

9
10 611 In conclusion, the data presented indicate that environmental stresses such as nutrient
11
12 612 starvation, heat exposure and hyper-osmotic stress all reduced the extracellular and intra-amoeba
13
14 613 survival of *C. jejuni* while only starvation affected bacterial uptake by amoeba. The observed
15
16 614 changes were not correlated directly with stress-induced changes in transcription of virulence-
17
18 615 associated genes of *C. jejuni*. Oxidative stress had no impact on bacterial extracellular survival or
19
20 616 on any aspects of amoeba/bacteria interactions, suggesting that *C. jejuni* is well equipped to fight
21
22 617 off a moderate oxidative stress and that this pre-exposure does not enhance its ability to respond
23
24 618 to further intracellular oxidative damage. While no effect of inhibitors of phago-lysosome fusion
25
26 619 or of PI 3-kinase were observed, the microfilament inhibitor cytochalasin D inhibited *C. jejuni*
27
28 620 uptake by amoeba, indicating that actin polymerization is involved in the uptake of *C. jejuni* by
29
30 621 *A. castellanii*. The effect of this inhibitor was exacerbated by starvation of the bacteria prior to
31
32 622 co-culture with amoeba, consistent again with our hypothesis described above that starved *C.*
33
34 623 *jejuni* are more prone to intracellular killing. Overall, pre-exposure to stress in the outside
35
36 624 environment does not seem to prime the bacteria for resistance against further insult by the
37
38 625 amoeba-killing machinery.

626 627 **Acknowledgements**

628 This study was supported in part by the Pathos Project funded by the Strategic Research Council
629 of Denmark (ENV 2104-07-0015) and Otto Mønsted Foundation, and in part by the Natural
630 Sciences and Engineering Research Council of Canada (RGPIN 240762-2010 to Dr. Creuzenet).

631 We thank Dr. Valvano for sharing the tissue culture facility and microscopes, and Dr. Koval for
632 the use of her microscope. We also thank R. Ford for critical reading of this manuscript.

633 The authors declare no conflict of interest.

634

635 **References**

636 Abee T & Wouters JA (1999) Microbial stress response in minimal processing. *Int J Food*
637 *Microbiol* **50**: 65-91.

638 Akya A, Pointon A & Thomas C (2009) Mechanism involved in phagocytosis and killing of
639 *Listeria monocytogenes* by *Acanthamoeba polyphaga*. *Parasitol Res* **105**: 1375-1383.

640 Allen KJ, Lepp D, McKellar RC & Griffiths MW (2008) Examination of stress and virulence
641 gene expression in *Escherichia coli* O157:H7 using targeted microarray analysis.
642 *Foodborne Pathog Dis* **5**: 437-447.

643 Allos BM (2001) *Campylobacter jejuni* infections: update on emerging issues and trends. *Clin*
644 *Infect Dis* **32**: 1201-1206.

645 Alsam S, Sissons J, Jayasekera S & Khan NA (2005) Extracellular proteases of *Acanthamoeba*
646 *castellanii* (encephalitis isolate belonging to T1 genotype) contribute to increased
647 permeability in an in vitro model of the human blood-brain barrier. *J Infect* **51**: 150-156.

648 Alter T & Scherer K (2006) Stress response of *Campylobacter* spp. and its role in food
649 processing. *J Vet Med B Infect Dis Vet Public Health* **53**: 351-357.

650 Avery SV, Harwood JL & Lloyd D (1995) Quantification and characterization of phagocytosis in
651 the soil amoeba *Acanthamoeba castellanii* by flow cytometry. *Appl Environ Microbiol*
652 **61**: 1124-1132.

- 1
2
3 653 Axelsson-Olsson D, Olofsson J, Svensson L, Griekspoor P, Waldenström J, Ellström P, *et al.*
4
5
6 654 (2010) Amoebae and algae can prolong the survival of *Campylobacter* species in co-
7
8 655 culture. *Exp Parasitol* **126**: 59-64.
9
10 656 Axelsson-Olsson D, Waldenstrom J, Broman T, Olsen B & Holmberg M (2005) Protozoan
11
12 657 *Acanthamoeba polyphaga* as a potential reservoir for *Campylobacter jejuni*. *Appl*
13
14 658 *Environ Microbiol* **71**: 987-992.
15
16
17 659 Baek K, Vegge C & Brondsted L (2011a) *HtrA* chaperone activity contributes to host cell
18
19 660 binding in *Campylobacter jejuni*. *Gut Pathog* **3**: 13.
20
21
22 661 Baek KT, Vegge CS, Skorko-Glonek J & Brondsted L (2011b) Different contributions of *HtrA*
23
24 662 protease and chaperone activities to *Campylobacter jejuni* stress tolerance and
25
26 663 physiology. *Appl Environ Microbiol* **77**: 57-66.
27
28
29 664 Baré J, Sabbe K, Huws S, Vercauteren D, Braeckmans K, Van Gremberghe I (2010) Influence of
30
31 665 temperature, oxygen and bacterial strain identity on the association of *Campylobacter*
32
33 666 *jejuni* with *Acanthamoeba castellanii*. *FEMS Microbiol Ecol* **74**: 371-381.
34
35
36 667 Beery JT, Hugdahl MB & Doyle MP (1988) Colonization of gastrointestinal tracts of chicks by
37
38 668 *Campylobacter jejuni*. *Appl Environ Microbiol* **54**: 2365-2370.
39
40
41 669 Biswas D, Itoh K & Sasakawa C (2000) Uptake pathways of clinical and healthy animal isolates
42
43 670 of *Campylobacter jejuni* into INT-407 cells. *FEMS Immunol Med Microbiol* **29**: 203-211.
44
45
46 671 Blaser MJ (1997) Epidemiologic and clinical features of *Campylobacter jejuni* infections. *J*
47
48 672 *Infect Dis* **176**: S103-S105.
49
50
51 673 Bolton FJ, Hinchliffe PM, Coates D & Robertson L (1982) A most probable number method for
52
53 674 estimating small numbers of campylobacters in water. *J Hyg (Lond)* **89**: 185-190.
54
55
56
57
58
59
60

- 1
2
3 675 Bottone EJ, Pere AA, Gordon RE & Qureshi MN (1994) Differential binding capacity and
4
5
6 676 internalisation of bacterial substrates as factors in growth rate of *Acanthamoeba* spp. *J*
7
8 677 *Med Microbiol* **40**: 148-154.
- 9
10 678 Brondsted L, Andersen MT, Parker M, Jorgensen K & Ingmer H (2005) The *HtrA* protease of
11
12 679 *Campylobacter jejuni* is required for heat and oxygen tolerance and for optimal
13
14 680 interaction with human epithelial cells. *Appl Environ Microbiol* **71**: 3205-3212.
- 15
16
17 681 Bui XT, Wolff A, Madsen M & Bang DD (2012) Reverse transcriptase real-time PCR for
18
19 682 detection and quantification of viable *Campylobacter jejuni* directly from poultry faecal
20
21 683 samples. *Res Microbiol* **163**: 64-72.
- 22
23
24 684 Bui XT, Winding A, Qvortrup K, Wolff A, Bang DD & Creuzenet C (2011) Survival of
25
26 685 *Campylobacter jejuni* in co-culture with *Acanthamoeba castellanii*: role of amoeba-
27
28 686 mediated depletion of dissolved oxygen. *Environ Microbiol* doi: 10.1111/j.1462-
29
30 687 2920.2011.02655.x.
- 31
32
33 688 Candon HL, Allan BJ, Fraley CD & Gaynor EC (2007) Polyphosphate kinase 1 is a pathogenesis
34
35 689 determinant in *Campylobacter jejuni*. *J Bacteriol* **189**: 8099-8108.
- 36
37
38 690 Cappelier JM, Minet J, Magras C, Colwell RR & Federighi M (1999) Recovery in embryonated
39
40 691 eggs of viable but nonculturable *Campylobacter jejuni* cells and maintenance of ability to
41
42 692 adhere to HeLa cells after resuscitation. *Appl Environ Microbiol* **65**: 5154-5157.
- 43
44
45 693 Champion OL, Karlyshev AV, Senior NJ, Woodward M, La Ragione R, Howard SL, *et al.*
46
47 694 (2010) Insect infection model for *Campylobacter jejuni* reveals that O-methyl
48
49 695 phosphoramidate has insecticidal activity. *J Infect Dis* **201**: 776-782.
- 50
51
52
53
54
55
56
57
58
59
60

- 1
2
3 696 Chenna R, Sugawara H, Koike T, Lopez R, Gibson TJ, Higgins DG, *et al.* (2003) Multiple
4
5
6 697 sequence alignment with the clustal series of programs. *Nucleic Acids Res* **31**: 3497-
7
8 698 3500.
9
10 699 Clark CG, Price L, Ahmed R, *et al.* (2003) Characterization of waterborne outbreak-associated
11
12 700 *Campylobacter jejuni*, Walkerton, Ontario. *Emerg Infect Dis* **9**: 1232–1241.
13
14 701 Cooper JA (1987) Effects of cytochalasin and phalloidin on actin. *J Cell Biol* **105**: 1473-1478.
15
16 702 Downey GP, Botelho RJ, Butler JR, Moltyaner Y, Chien P, Schreiber AD, *et al.* (1999)
17
18 703 Phagosomal maturation, acidification, and inhibition of bacterial growth in
19
20 704 nonphagocytic cells transfected with FcγRIIA receptors. *J Biol Chem* **274**: 28436-28444.
21
22 705 Fields JA & Thompson SA (2008) *Campylobacter jejuni* CsrA mediates oxidative stress
23
24 706 responses, biofilm formation, and host cell invasion. *J Bacteriol* **190**: 3411-3416.
25
26 707 Friedman CR, Neimann J, Wegener HC & Tauxe RV (2000) *Campylobacter jejuni* infections in
27
28 708 the United States and other industrialized nations. In: Nachamkin I & (Ed.) MJB (eds.)
29
30 709 *Campylobacter*. 2 ed. Washington, DC, ASM Press.
31
32 710 Gangaiah D, Liu Z, Arcos J, Kassem II, Sanad Y, Torrelles JB, *et al.* (2010) Polyphosphate
33
34 711 kinase 2: A novel determinant of stress responses and pathogenesis in *Campylobacter*
35
36 712 *jejuni*. *PLoS ONE* **5**: e12142.
37
38 713 Gundogdu O, Mills DC, Elmi A, Martin MJ, Wren BW & Dorrell N (2011) The *Campylobacter*
39
40 714 *jejuni* transcriptional regulator Cj1556 plays a role in the oxidative and aerobic stress
41
42 715 response and is important for bacterial survival in vivo. *J Bacteriol* **193**: 4238-4249.
43
44 716 Hanninen M-L, Haajanen H, Pummi T, Wermundsen K, Katila M-L, Sarkkinen H, *et al.* (2003)
45
46 717 Detection and typing of *Campylobacter jejuni* and *Campylobacter coli* and analysis of
47
48
49
50
51
52
53
54
55
56
57
58
59
60

- 1
2
3 718 indicator organisms in three waterborne outbreaks in Finland. *Appl Environ Microbiol*
4
5
6 719 **69**: 1391-1396.
- 7
8 720 Hu L, Mcdaniel JP & Kopecko DJ (2006) Signal transduction events involved in human
9
10 721 epithelial cell invasion by *Campylobacter jejuni* 81-176. *Microb Pathog* **40**: 91-100.
- 11
12 722 Hughes R (2004) *Campylobacter jejuni* in Guillain-Barré syndrome. *Lancet Neurol* **3**: 644.
- 13
14
15 723 Jackson D, Davis B, Tirado S, Duggal M, Van Frankenhuyzen J, Deaville D, *et al.* (2009)
16
17 724 Survival mechanisms and culturability of *Campylobacter jejuni* under stress conditions.
18
19
20 725 *Antonie van Leeuwenhoek* **96**: 377-394.
- 21
22 726 King CH, Fields BS, Shotts EB, Jr & White EH (1991) Effects of cytochalasin D and
23
24 727 methylamine on intracellular growth of *Legionella pneumophila* in amoebae and human
25
26 728 monocyte-like cells. *Infect Immun* **59**: 758-763.
- 27
28
29 729 Klančnik A, Botteldoorn N, Herman L & Možina SS (2006) Survival and stress induced
30
31 730 expression of groEL and rpoD of *Campylobacter jejuni* from different growth phases. *Int*
32
33 731 *J Food Microbiol* **112**: 200-207.
- 34
35
36 732 Klančnik A, Guzej B, Jamnik P, Vučković D, Abram M & Možina SS (2009) Stress response
37
38 733 and pathogenic potential of *Campylobacter jejuni* cells exposed to starvation. *Res*
39
40 734 *Microbiol* **160**: 345-352.
- 41
42
43 735 Konkel ME, Kim BJ, Klena JD, Young CR & Ziprin R (1998) Characterization of the thermal
44
45 736 stress response of *Campylobacter jejuni*. *Infect Immun* **66**: 3666-3672.
- 46
47
48 737 Konkel ME, Kim BJ, Rivera-Amill V & Garvis SG (1999) Bacterial secreted proteins are
49
50 738 required for the internalization of *Campylobacter jejuni* into cultured mammalian cells.
51
52 739 *Mol Microbiol* **32**: 691-701.
- 53
54
55
56
57
58
59
60

- 1
2
3 740 Laskowska E, Kuczyńska-Wiśnik D, Skórko-Glonek J & Taylor A (1996) Degradation by
4
5 741 proteases Lon, Clp and *HtrA*, of *Escherichia coli* proteins aggregated in vivo by heat
6
7 742 shock; *HtrA* protease action in vivo and in vitro. *Mol Microbiol* **22**: 555-571.
8
9
10 743 Levchenko A & Iglesias PA (2002) Models of eukaryotic gradient sensing: application to
11
12 744 chemotaxis of amoebae and neutrophils. *Biophys J* **82**: 50-63.
13
14
15 745 Li S, Dorrell N, Everest P, Dougan G & Wren B (1996) Construction and characterization of a
16
17 746 *Yersinia enterocolitica* O:8 high- temperature requirement (*htrA*) isogenic mutant. *Infect*
18
19 747 *Immun* **64**: 2088-2094.
20
21
22 748 Li Y-P, Ingmer H, Madsen M & Bang D (2008) Cytokine responses in primary chicken embryo
23
24 749 intestinal cells infected with *Campylobacter jejuni* strains of human and chicken origin
25
26 750 and the expression of bacterial virulence-associated genes. *BMC Microbiol* **8**: 107.
27
28
29 751 Livak KJ & Schmittgen TD (2001) Analysis of relative gene expression data using real-time
30
31 752 quantitative PCR and the $2^{-\Delta\Delta CT}$ method. *Methods* **25**: 402-408.
32
33
34 753 Ma Yue, Hanning I & Slavik M (2009) Stress-induced adaptive tolerance response and virulence
35
36 754 gene expression in *Campylobacter jejuni*. *J Food Safety* **29**: 126-143.
37
38
39 755 Malik-Kale P, Parker CT & Konkel ME (2008) Culture of *Campylobacter jejuni* with sodium
40
41 756 deoxycholate induces virulence gene expression. *J Bacteriol* **190**: 2286-2297.
42
43
44 757 Mekalanos JJ (1992) Environmental signals controlling expression of virulence determinants in
45
46 758 bacteria. *J Bacteriol* **174**: 1-7.
47
48
49 759 Mihaljevic RR, Sikic M, Klancnik A, Brumini G, Mozina SS & Abram M (2007) Environmental
50
51 760 stress factors affecting survival and virulence of *Campylobacter jejuni*. *Microb Pathog*
52
53 761 **43**: 120-125.
54
55
56
57
58
59
60

- 1
2
3 762 Moffat JF & Tompkins LS (1992) A quantitative model of intracellular growth of *Legionella*
4
5 763 *pneumophila* in *Acanthamoeba castellanii*. *Infect Immun* **60**: 296-301.
6
7
8 764 Monteville MR, Yoon JE & Konkel ME (2003) Maximal adherence and invasion of INT 407
9
10 765 cells by *Campylobacter jejuni* requires the CadF outer-membrane protein and
11
12 766 microfilament reorganization. *Microbiology* **149**: 153-165.
13
14
15 767 Murphy C, Carroll C & Jordan KN (2003) Induction of an adaptive tolerance response in the
16
17 768 foodborne pathogen, *Campylobacter jejuni*. *FEMS Microbiol Lett* **223**, 89-93.
18
19
20 769 Murphy C, Carroll C & Jordan KN (2006) Environmental survival mechanisms of the foodborne
21
22 770 pathogen *Campylobacter jejuni*. *J Appl Microbiol* **100**: 623-632.
23
24
25 771 Newton JM & Surawicz CM (2011) Infectious gastroenteritis and colitis diarrhea. In: Guandalini
26
27 772 S & Vaziri H (eds.), Humana Press.
28
29
30 773 Oelschlaeger TA, Guerry P & Kopecko DJ (1993) Unusual microtubule-dependent endocytosis
31
32 774 mechanisms triggered by *Campylobacter jejuni* and *Citrobacter freundii*. *Proc Natl Acad*
33
34 775 *Sci U S A*. **90**: 6884-6888.
35
36
37 776 Palyada K, Sun Y-Q, Flint A, Butcher J, Naikare H & Stintzi A (2009) Characterization of the
38
39 777 oxidative stress stimulon and PerR regulon of *Campylobacter jejuni*. *BMC Genomics* **10**:
40
41 778 481.
42
43
44 779 Pesanti EL (1978) Suramin effects on macrophage phagolysosome formation and antimicrobial
45
46 780 activity. *Infect Immun* **20**: 503-511.
47
48
49 781 Pogačar MŠ, Klančnik A, Možina SS & Cencič A (2009) Attachment, invasion, and
50
51 782 translocation of *Campylobacter jejuni* in pig small-intestinal epithelial cells. *Foodborne*
52
53 783 *Pathog Dis* **7**: 589-595.
54
55
56
57
58
59
60

- 1
2
3 784 Pogačar MŠ, Rubeša Mihaljević R, Klančnik A, Brumini G, Abram M & Smole Možina S
4
5
6 785 (2009b) Survival of stress exposed *Campylobacter jejuni* in the murine macrophage J774
7
8 786 cell line. *Int J Food Microbiol* **129**: 68-73.
9
10
11 787 Reezal A, Mcneil B & Anderson JG (1998) Effect of low-osmolality nutrient media on growth
12
13 788 and culturability of *Campylobacter* species. *Appl Environ Microbiol* **64**: 4643-4649.
14
15
16 789 Rohr U, Weber S, Michel R, Selenka F & Wilhelm M (1998) Comparison of free-living amoebae
17
18 790 in hot water systems of hospitals with isolates from moist sanitary areas by identifying
19
20 791 genera and determining temperature tolerance. *Appl Environ Microbiol* **64**: 1822-1824.
21
22
23 792 Sagarzazu N, Cebrián G, Condón S, Mackey B & Mañas P (2010) High hydrostatic pressure
24
25 793 resistance of *Campylobacter jejuni* after different sublethal stresses. *J Appl Microbiol*
26
27 794 **109**: 146-155.
28
29
30 795 Schuster FL & Visvesvara GS (2004) Free-living amoebae as opportunistic and non-
31
32 796 opportunistic pathogens of humans and animals. *Int J Parasitol* **34**: 1001-1027.
33
34
35 797 Snelling W, Stern N, Lowery C, Moore J, Gibbons E, Baker C, *et al.* (2008) Colonization of
36
37 798 broilers by *Campylobacter jejuni* internalized within *Acanthamoeba castellanii*. *Arch*
38
39 799 *Microbiol* **189**: 175-179.
40
41
42 800 Snelling WJ, Mckenna JP, Lecky DM & Dooley JSG (2005) Survival of *Campylobacter jejuni* in
43
44 801 waterborne protozoa. *Appl Environ Microbiol* **71**: 5560-5571.
45
46
47 802 Stintzi A (2003) Gene expression profile of *Campylobacter jejuni* in response to growth
48
49 803 temperature variation. *J Bacteriol* **185**: 2009-2016.
50
51
52 804 Styrts B & Klempner MS (1988) Effects of pH on killing of *Staphylococcus aureus* and
53
54 805 *Escherichia coli* by constituents of the neutrophil phagolysosome. *J Med Microbiol* **25**:
55
56 806 101-107.
57
58
59
60

- 1
2
3 807 Thomas C, Hill D & Mabey M (2002) Culturability, injury and morphological dynamics of
4
5 808 thermophilic *Campylobacter* spp. within a laboratory-based aquatic model system. *J Appl*
6
7
8 809 *Microbiol* **92**: 433-442.
9
- 10 810 Thomas C, Hill DJ & Mabey M (1999) Evaluation of the effect of temperature and nutrients on
11
12 811 the survival of *Campylobacter* spp. in water microcosms. *J Appl Microbiol* **86**: 1024-
13
14 812 1032.
15
- 16
17 813 Thomas V, Loret J-F, Jousset M & Greub G (2008) Biodiversity of amoebae and amoebae-
18
19 814 resisting bacteria in a drinking water treatment plant. *Environ Microbiol* **10**: 2728-2745.
20
- 21
22 815 Thomas V, McDonnell G, Denyer SP & Maillard J-Y (2010) Free-living amoebae and their
23
24 816 intracellular pathogenic microorganisms: risks for water quality. *FEMS Microbiol Rev*
25
26 817 **34**: 231-259.
27
- 28
29 818 van Vliet AHM, Baillon M-LA, Penn CW & Ketley JM (1999) *Campylobacter jejuni* contains
30
31 819 two Fur homologs: characterization of iron-responsive regulation of peroxide stress
32
33 820 defense genes by the PerR repressor. *J Bacteriol* **181**: 6371-6376.
34
35
- 36 821 Wassenaar TM, Engelskirchen M, Park S & Lastovica A (1997) Differential uptake and killing
37
38 822 potential of *Campylobacter jejuni* by human peripheral monocytes/macrophages. *Med*
39
40 823 *Microbiol Immunol* **186**: 139-144.
41
42
- 43 824 Watson RO & Galán JE (2008) *Campylobacter jejuni* survives within epithelial cells by avoiding
44
45 825 delivery to lysosomes. *PLoS Pathog* **4**: e14.
46
47
- 48 826 Weidner E & Sibley LD (1985) Phagocytized intracellular microsporidian blocks phagosome
49
50 827 acidification and phagosome-lysosome fusion. *J Protozool* **32**: 311-317.
51
52
- 53 828 Wooldridge KG, Williams PH & Ketley JM (1996) Host signal transduction and endocytosis of
54
55 829 *Campylobacter jejuni*. *Microb Pathog* **21**: 299-305.
56
57
58
59
60

1
2
3 830 Young KT, Davis LM & Dirita VJ (2007) *Campylobacter jejuni*: molecular biology and
4
5
6 831 pathogenesis. *Nat Rev Micro* **5**: 665-679.

7
8 832 Ziprin RL, Young CR, Byrd JA, Stanker LH, Hume ME, Gray SA, *et al.* (2001) Role of
9
10 833 *Campylobacter jejuni* potential virulence genes in cecal colonization. *Avian Dis* **45**: 549-
11
12
13 834 557.

14
15 835

16
17
18 836

19
20
21
22 837

For Peer Review

1
2
3 838 **Figure legends**
4

5
6 839 **Fig. 1** Survival of *C. jejuni* cells exposed to environmental stresses. Survival was determined by
7
8
9 840 counting colony forming units (CFU). Data are means and standard errors of at least three
10
11 841 independent experiments. (*), $p < 0.05$; (ns), not significant.
12

13
14 842 **Fig. 2** qRT-PCR analysis of the impact of the various stresses on transcription of virulence-
15
16 associated genes of *C. jejuni*. Total RNA was isolated, and the expression of *ciaB*, *dnaJ* and *htrA*
17 843 was measured immediately after exposure to each stress. All data were normalized to the level of
18
19 844 expression of the *16S rRNA* gene. The differences are considered significant for 2 fold difference
20
21 845 compared with non-stressed bacterial controls. The interval for non significant variation (NSV)
22
23 846 is delimited by dotted lines. Data are representative of three independent experiments from three
24
25 847 different RNA extracts.
26
27
28
29
30

31
32 849 **Fig. 3** Intracellular survival rates of *C. jejuni* cells within *A. castellanii* as determined by colony
33
34 850 forming unit (CFU) counting at 0, 5, and 24 h post gentamicin treatment at 25°C in aerobic
35
36 851 conditions. Panel A: comparison of wild-type (WT) and *htrA* mutant. Panel B: comparison of
37
38 852 stressed and non-stressed wild-type bacteria. Data are means and standard errors of at least three
39
40 853 independent experiments. (*) $p < 0.01$; (**) $p < 0.05$; (ns) not significant.
41
42
43

44 854 **Fig. 4** Confocal microscopy analysis of stressed and non-stressed *C. jejuni* cells within acidic
45
46 855 organelles of *A. castellanii* observed immediately after gentamicin treatment. Control *C. jejuni*
47
48 856 (A-D), *C. jejuni* pre-exposed to osmotic stress (E-H), heat stress (I-L), hydrogen peroxide (M-P),
49
50 857 or starvation stress (Q-T). The multiplicity of infection was 100:1 (bacteria:amoeba). (A, E, I, M,
51
52 858 Q) differential interference contrast image; (B, F, J, N, R) *C. jejuni* stained with CellTracker
53
54
55
56
57
58
59
60

1
2
3 859 Red; (C, G, K, O, S) acidic amoeba organelles stained with LysoSensor Green; (D, H, L, P, T)
4
5
6 860 corresponding overlay. Scale bar = 5 μm .

7
8 861 **Fig. 5** TEM of control *C. jejuni* and *C. jejuni* pre-exposed to heat stress within vacuoles of *A.*
9
10 862 *castellanii* trophozoites at different time points. At 0 h after gentamicin treatment, control *C.*
11
12 863 *jejuni* (A) and *C. jejuni* pre-exposed to heat stress (C). At 5 h after gentamicin treatment, control
13
14 864 *C. jejuni* (B and with zoom out in E) and heat stressed *C. jejuni* (D and with zoom out in F). The
15
16 865 white arrows (A, B, C, D) show *C. jejuni* cells inside amoeba vacuoles. Black arrows (E and F)
17
18 866 show partial degradation of intracellular bacteria within *A. castellanii*, whereas white arrows
19
20 867 show normal intracellular bacterial cells.

21
22
23
24
25 868 **Fig. 6** Uptake of stressed and non-stressed *C. jejuni* cells by *A. castellanii* pretreated with
26
27 869 wortmannin or cytochalasin D as measured by CFU counting right after gentamicin treatment.
28
29 870 Data are means and standard errors of at least three independent experiments. (*), $p < 0.01$ for
30
31 871 each stress, relatively to the no cytochalasin and no wortmannin control.

32
33
34
35
36 872 **Fig. 7** Intracellular survival of non-stressed *C. jejuni* in suramin and monensin pre-treated *A.*
37
38 873 *castellanii* cells at 0 and 5 h post gentamicin treatment, as determined by CFU counting. Data are
39
40 874 means and standard errors of at least three independent experiments.

41
42
43
44 875 **Fig. 8** Confocal microscopy analysis of the impact of monensin and suramin on acidification of
45
46 876 phagocytic vacuoles within *A. castellanii*. The amoeba were pre-treated with monensin (A-D) or
47
48 877 suramin (E-H) for 1 h before co-culturing and CLSM images were taken at 0 h post gentamicin
49
50 878 treatment. Only non-stress bacteria were used for this test. The multiplicity of infection was
51
52 879 100:1 (bacteria:amoeba). (A, E) differential interference contrast image; (B, F) *C. jejuni* stained

1
2
3 880 with CellTracker Red; (C, G) acidic amoeba organelles stained with LysoSensor Green; (D, H)
4
5
6 881 corresponding overlay. Scale bar = 5 μ m.
7
8 882
9

For Peer Review

1

2 Table 1. Primers used in this study

Genes	Primer sequences (5'-3')	Amplicons (bp)	references
<i>16S RNA-F</i> <i>16S RNA-R</i>	AACCTTACCTGGGCTTGATA CTTAACCCAACATCTCACGA	122	3 4 5 6 (Li <i>et al.</i> , 2008)
<i>ciaB-F</i> <i>ciaB-R</i>	ATATTTGCTAGCAGCGAAGAG GATGTCCCACTTGTAAGGTG	157	8 (Li <i>et al.</i> , 2008)
<i>dnaJ-F</i> <i>dna-R</i>	AGTGTCGAGCTTAATATCCC GGCGATGATCTTAACATACA	117	10 (Li <i>et al.</i> , 2008)
<i>htrA-F</i> <i>htrA-R</i>	CCATTGCGATATACCCAAACTT CTGGTTTCCAAGAGGGTGAT	130	12 This study

14

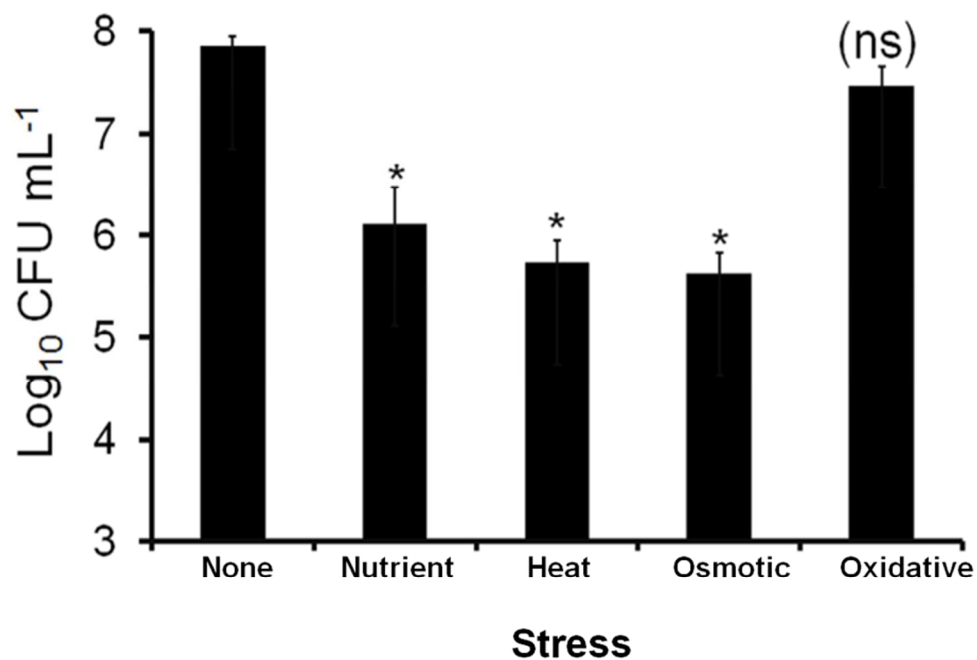

Survival of *C. jejuni* cells exposed to environmental stresses. Survival was determined by counting colony forming units (CFU). Data are means and standard errors of at least three independent experiments. (*), $p < 0.05$; (ns), not significant.
80x54mm (300 x 300 DPI)

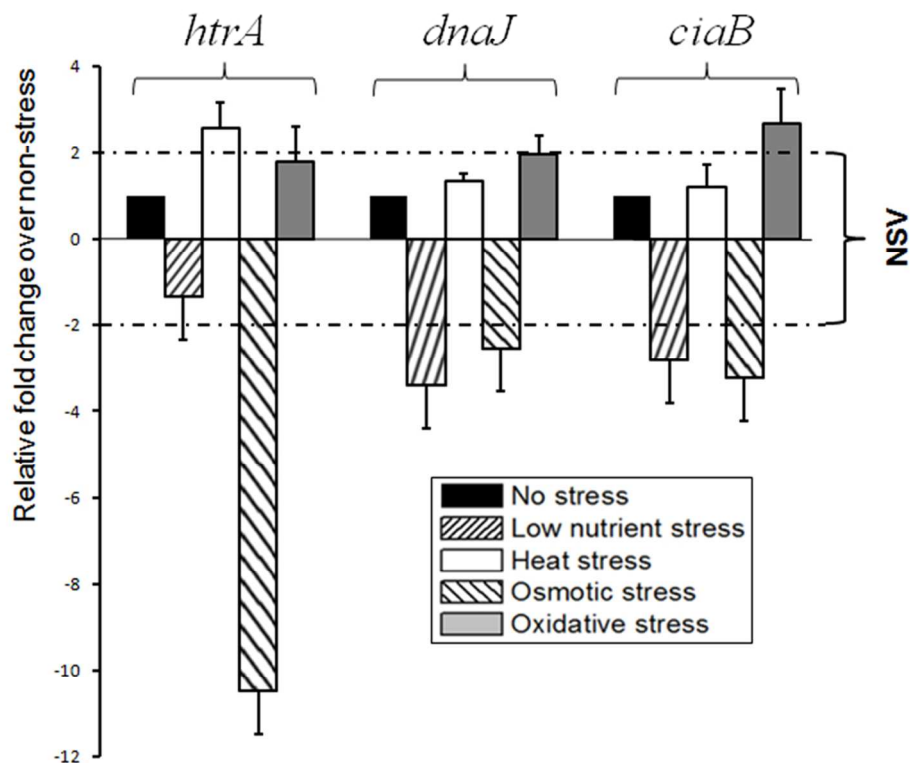

qRT-PCR analysis of the impact of the various stresses on transcription of virulence-associated genes of *C. jejuni*. Total RNA was isolated, and the expression of *ciaB*, *dnaJ* and *htrA* was measured immediately after exposure to each stress. All data were normalized to the level of expression of the 16S rRNA gene. The differences are considered significant for 2 fold difference compared with non-stressed bacterial controls. The interval for non significant variation (NSV) is delimited by dotted lines. Data are representative of three independent experiments from three different RNA extracts.

80x67mm (300 x 300 DPI)

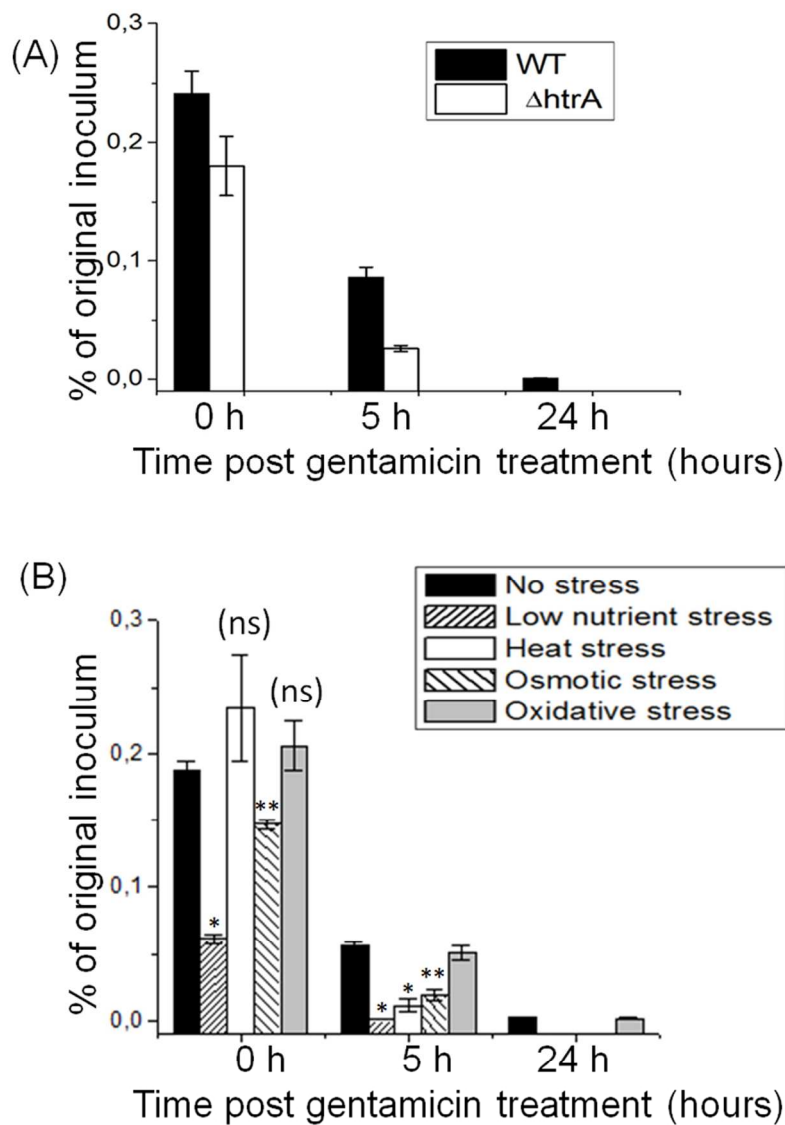

46 Intracellular survival rates of *C. jejuni* cells within *A. castellanii* as determined by colony forming unit (CFU)
 47 counting at 0, 5, and 24 h post gentamicin treatment at 25°C in aerobic conditions. Panel A: comparison of
 48 wild-type (WT) and *htrA* mutant. Panel B: comparison of stressed and non-stressed wild-type bacteria. Data
 49 are means and standard errors of at least three independent experiments. (*) $p < 0.01$; (**) $p < 0.05$; (ns)
 50 not significant.

51 80x117mm (300 x 300 DPI)

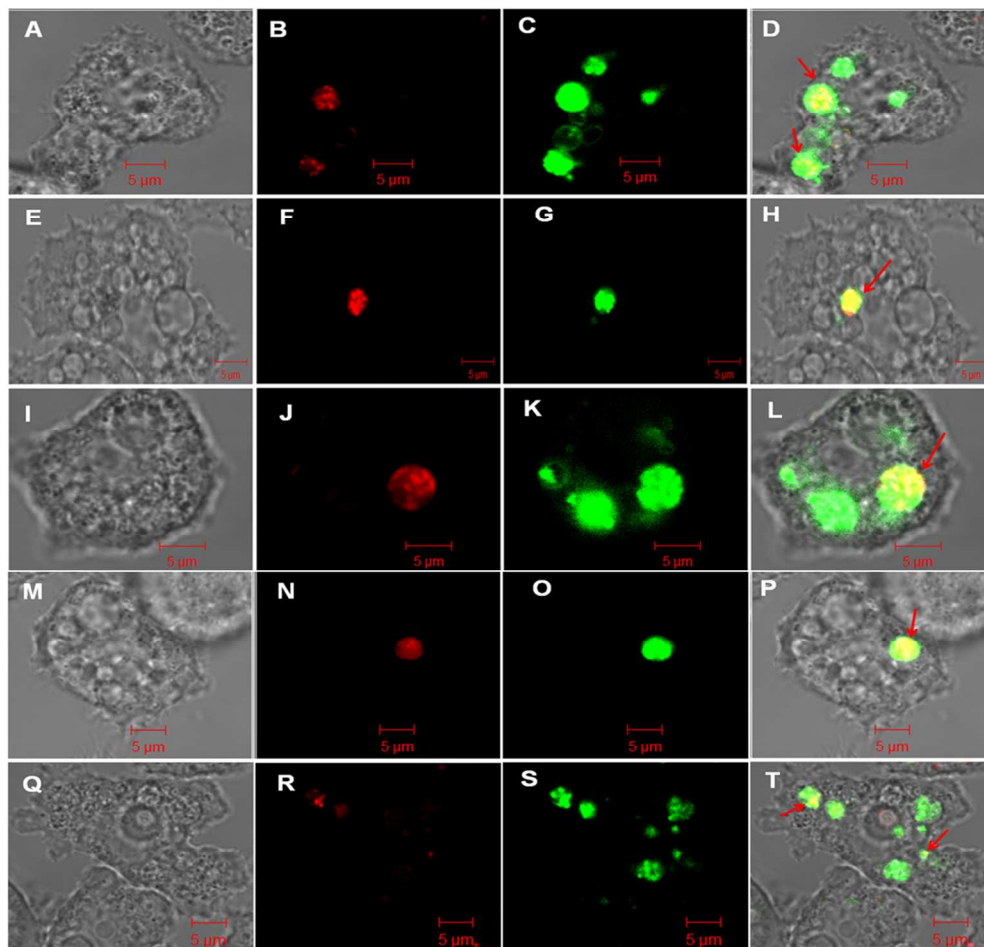

Confocal microscopy analysis of stressed and non-stressed *C. jejuni* cells within acidic organelles of *A. castellanii* observed immediately after gentamicin treatment. Control *C. jejuni* (A-D), *C. jejuni* pre-exposed to osmotic stress (E-H), heat stress (I-L), hydrogen peroxide (M-P), or starvation stress (Q-T). The multiplicity of infection was 100:1 (bacteria:amoeba). (A, E, I, M, Q) differential interference contrast image; (B, F, J, N, R) *C. jejuni* stained with CellTracker Red; (C, G, K, O, S) acidic amoeba organelles stained with LysoSensor Green; (D, H, L, P, T) corresponding overlay. Scale bar = 5 μm. 160x151mm (300 x 300 DPI)

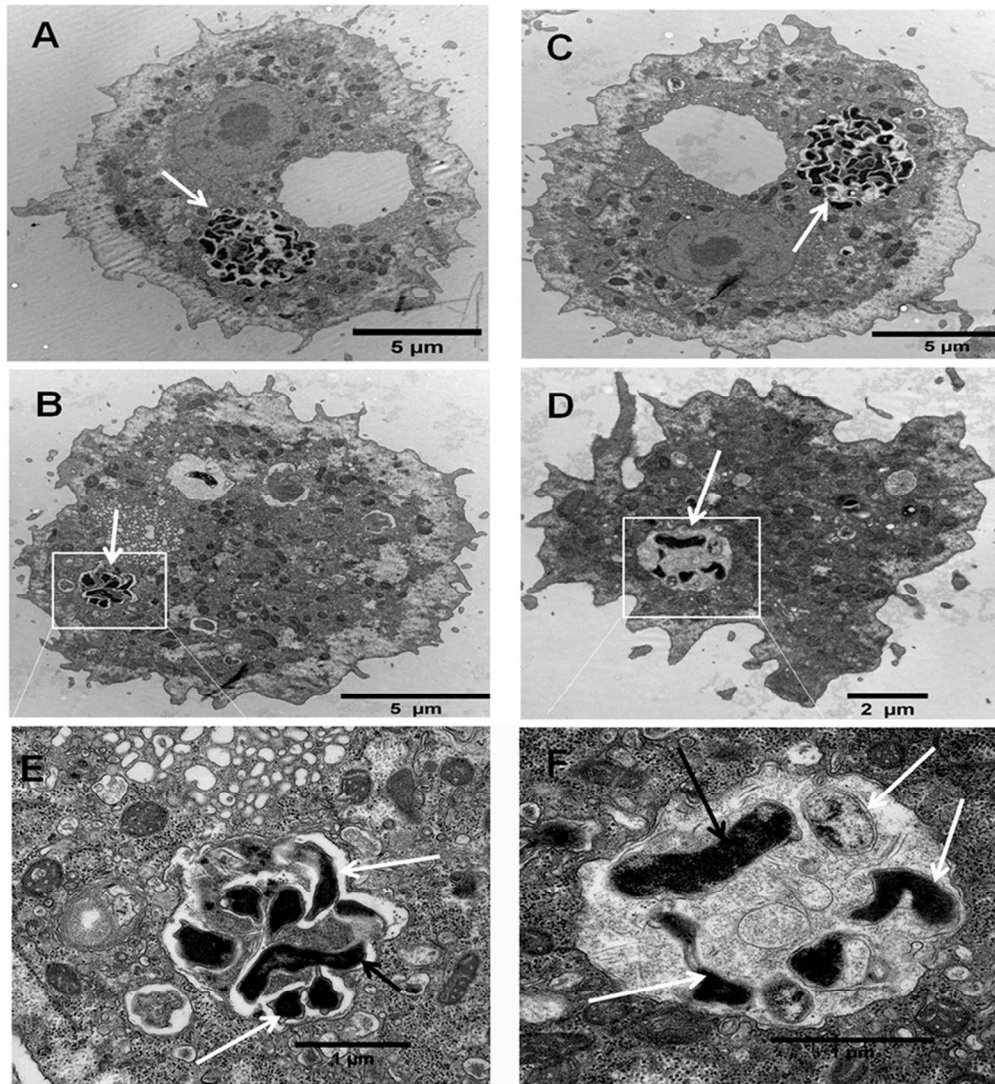

TEM of control *C. jejuni* and *C. jejuni* pre-exposed to heat stress within vacuoles of *A. castellanii* trophozoites at different time points. At 0 h after gentamicin treatment, control *C. jejuni* (A) and *C. jejuni* pre-exposed to heat stress (C). At 5 h after gentamicin treatment, control *C. jejuni* (B and with zoom out in E) and heat stressed *C. jejuni* (D and with zoom out in F). The white arrows (A, B, C, D) show *C. jejuni* cells inside amoeba vacuoles. Black arrows (E and F) show partial degradation of intracellular bacteria within *A. castellanii*, whereas white arrows show normal intracellular bacterial cells.

160x174mm (300 x 300 DPI)

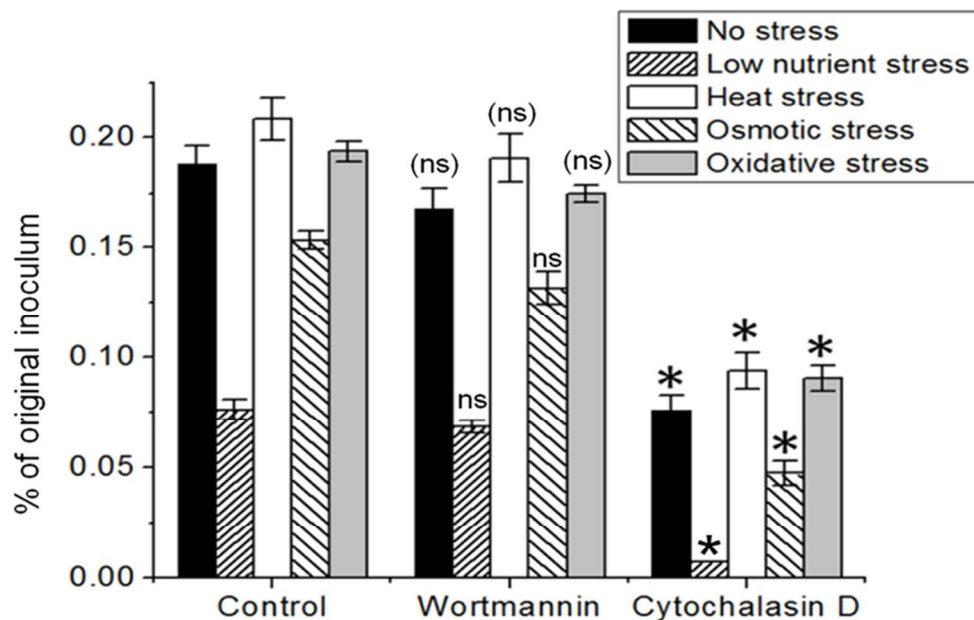

Uptake of stressed and non-stressed *C. jejuni* cells by *A. castellanii* pretreated with wortmannin or cytochalasin D as measured by CFU counting right after gentamicin treatment. Data are means and standard errors of at least three independent experiments. (*), $p < 0.01$ for each stress, relatively to the no cytochalasin and no wortmannin control.

80x50mm (300 x 300 DPI)

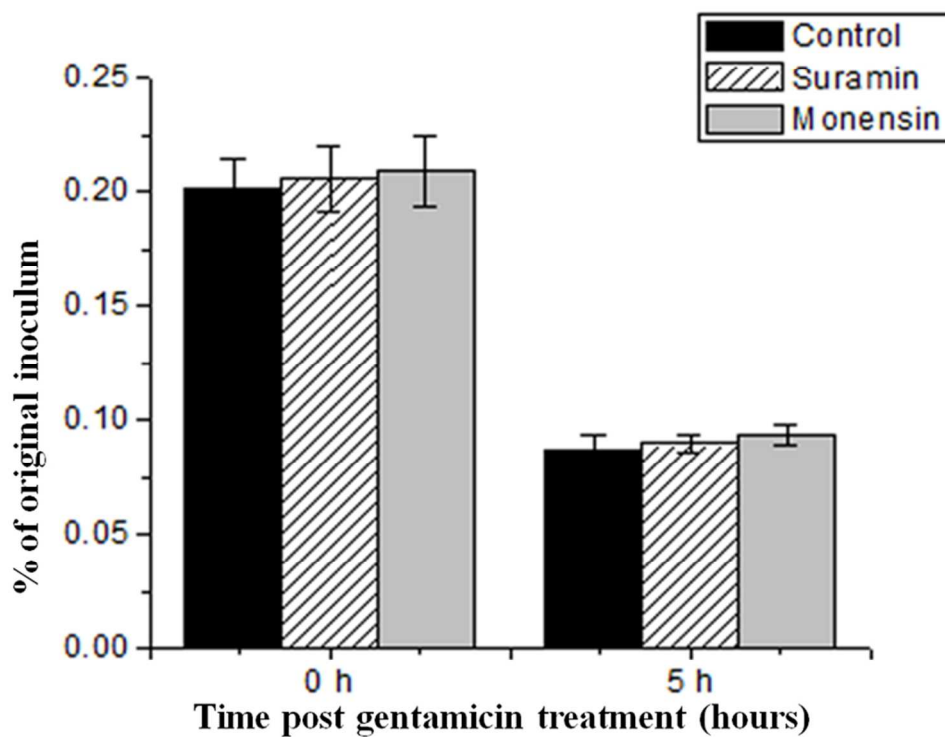

Intracellular survival of non-stressed *C. jejuni* in suramin and monensin pre-treated *A. castellanii* cells at 0 and 5 h post gentamicin treatment, as determined by CFU counting. Data are means and standard errors of at least three independent experiments.

80x63mm (300 x 300 DPI)

view

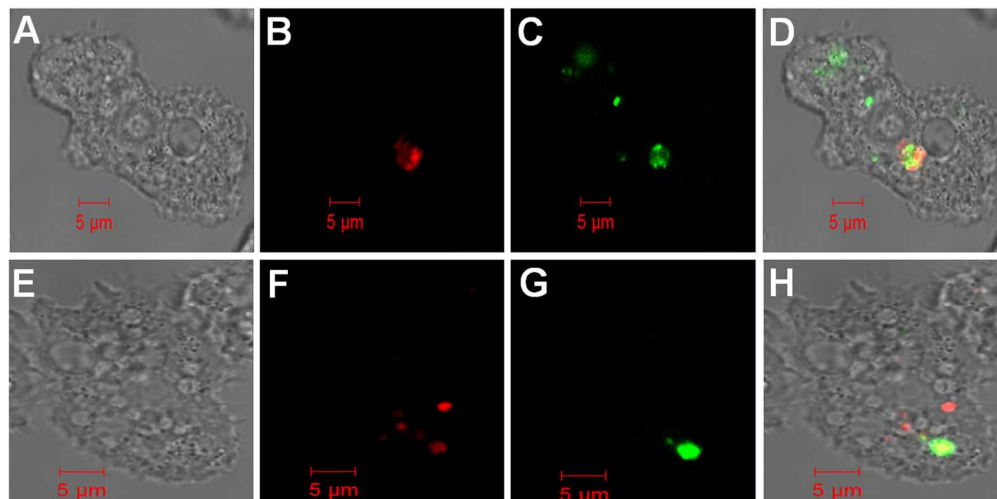

Confocal microscopy analysis of the impact of monensin and suramin on acidification of phagocytic vacuoles within *A. castellanii*. The amoeba were pre-treated with monensin (A-D) or suramin (E-H) for 1 h before co-culturing and CLSM images were taken at 0 h post gentamicin treatment. Only non-stress bacteria were used for this test. The multiplicity of infection was 100:1 (bacteria:amoeba). (A, E) differential interference contrast image; (B, F) *C. jejuni* stained with CellTracker Red; (C, G) acidic amoeba organelles stained with LysoSensor Green; (D, H) corresponding overlay. Scale bar = 5 μm.
160x79mm (300 x 300 DPI)

Chapter 8: Conclusions and Outlook

Campylobacter is the most common cause of food-borne illness worldwide. However, we know less about biology and pathogenicity of this pathogen than we do about other less prevalent pathogens. This PhD-study has focused on investigation of the survival and virulence of *Campylobacter* spp. in different matrixes such as chicken faeces, swine manure and in co-culture with protozoa.

Nowadays, DNA-based PCR assays are often used to rapidly detect *Campylobacter* spp. in different environments. However, DNA-based PCR assays do not discriminate the dead cells from living cells. In order to overcome that limitation, EMA- or PMA-PCR methods have recently been introduced to detect and differentiate dead and viable cells of *C. jejuni*. In this thesis (chapter 2), I have described the development of a new mRNA extraction method for detecting of *Campylobacter* directly from chicken fecal samples. The key point of this study was to use bacterial mRNA as a template to detect and quantify only viable *Campylobacter* spp. from poultry faeces - an abundance of inhibitor materials. It has been shown that the bacterial mRNA has a very short half-life (few hours) and it is therefore a good biomarker for viable bacterial cells. Using this method viable *C. jejuni* cells could be detected for up to 5 days in both *C. jejuni* spiked and naturally contaminated faecal samples. Interestingly, no RT-qPCR signals were obtained when viable *C. jejuni* cells could not be counted by the culture method. In contrast, using a DNA-based qPCR method, dead or non-viable *Campylobacter* cells were detected, since all tested samples were positive, even after 20 days of storage. The use of this mRNA method not only allows detection and quantification of viable *Campylobacter* spp. but also can be used to study the potential pathogenicity of this bacterium in chicken faeces and pig manure before applying to the agricultural soil.

Furthermore, the newly developed RT-qPCR was used in combination with a DNA-based qPCR and bacterial culture to study and quantify viable *C. coli* in swine manure in different storage

conditions. *C. coli* has often been found in pigs and pig manures, and the manure is widely used to fertilize the soil in traditional agricultural practice. It is therefore very important to know how this bacterium can survive during the storage before spreading to the agricultural soil. The survival of *C. coli* during storage for 30 days was studied. Using the three different methods, I have shown that *C. coli* could survive in swine manure up to 24 days at 4°C using RT-qPCR and culture methods. At higher temperatures, this bacterium survived only 7 days (15°C) or 6 days (22°C) of storage. The survival of *C. coli* was extremely short (few hours) in samples incubated at 42 and 52°C. The results of this study suggest that before swine manure is applied on the agricultural soil it should be treated properly by e.g. increasing the temperature up to 42°C or even more than 52°C for few hours since low temperatures allow *Campylobacters* survive a longer time (at least 24 days at 4°C).

As mentioned above, animal manure is widely used to fertilize the soil in traditional agricultural practice and this practice raises a question about the risks of contamination by manure-borne pathogens in vegetables, soil and groundwater. Furthermore, it has been shown that hormones and heavy metals from manure may have great impacts on the quality of groundwater as well as aquatic organisms due to the leaching of the field applied manure. A study of the potential pathogens which may leach and contaminate the soil and water using different manure fractions, manure application methods on soil column models was conducted in order to have a better understanding of what methods of manure application can be used to prevent the leaching and transporting of these pathogens in the soil to groundwater. The study was performed in cooperating and leading by Dr. Mostofa Amin at Aarhus University. The key points of this study were to examine how the pathogens (*Salmonella* Typhimurium phage type 28B, *E. coli* and *Enterococcus* spp) could survive and move in soil columns. The results of this study reveal that solid-liquid separation of slurry increased the redistribution of contaminants in liquid fraction in the soil column compared to raw slurry, and the recovery of *E. coli* and *Enterococcus* spp. was higher for liquid fraction after four

leaching events. Liquid fraction also resulted in higher leaching of all contaminants except *Enterococcus* spp. than raw slurry while the ozonation reduced only *E. coli* leaching. The outcome of this study suggested that by injection of manure into soil in 20 cm depth or using separation method and using the separated liquid fraction instead of the raw slurry to apply on the soil will reduce the potential leaching of pathogens (chapter 4).

In chapter 5, 6 and 7, the links between protozoa and different food-borne pathogens (*C. jejuni*, *S. Typhimurium*, and *L. monocytogenes*) were studied using the co-cultivation method. It has been reported that protozoa including amoebae have been found widely in broiler houses. Therefore, it is very important to study the impacts of protozoa on the survival of these food-borne pathogens. In these three chapters, I have described the interactions between *C. jejuni* and *A. castellanii* (Chapter 5) as well as other food-borne pathogens (*S. Typhimurium*, and *L. monocytogenes*) with a common soil flagellate, *Cercomonas* sp. (Chapter 6). The observations from these studies have revealed that *C. jejuni* does not survive ingestion by *A. castellanii* (only 5 h after gentamicin treatment) at 25°C in aerobic conditions. Conversely, the results have shown that *A. castellanii* promoted the extracellular growth of *C. jejuni* in co-cultures at 37°C in aerobic conditions. Interestingly, the depletion of dissolved oxygen by *A. castellanii* is the major contributor for the observed amoeba-mediated growth enhancement. In effect, this would allow preservation of the amoebae's food source while also resulting in continuous contamination of the flowing water. It will therefore be interesting to study the potential of *C. jejuni* for biofilm formation or further growth within biofilms in the presence of various amoebae under continuous flow (chapter 5). Furthermore, the data from the study of the interaction between three food-borne pathogens and *Cercomonas* sp. may open a window for a possibility of these pathogens from soil to enter human food chains (chapter 6). The cross contamination could be due to *Cercomonas* sp. itself as a vector carrying over the pathogens but it needs to be proved and examined by different methods. In addition, prolonging the survival of

food-borne pathogens in soil by *Cercomonas* sp. could increase the risk of other protozoa, insects, worms or wild birds to be a vector for the pathogens enter the food chains. Further study of what factor(s) contributing to prolong the survival of the bacterial pathogens in co-culture with *Cercomonas* sp. will be an interesting direction.

During transmission and infection, *C. jejuni* may encounter with many different stresses such as heat shock, starvation, osmosis, and oxidation. I have studied the impacts of these factors on the expression of three *C. jejuni* putative virulence genes (*ciaB*, *dnaJ*, and *htrA*) during intracellular survival within *A. castellanii*, as well as the mechanism(s) involved in phagocytosis and killing of *C. jejuni* by *A. castellanii*. The observations of this study reveal that heat and osmotic stresses reduced the survival of *C. jejuni* significantly. Using RT-qPCR to study expression of different virulence genes reveals that the transcription of the *dnaJ* and *ciaB* genes was not affected by heat stress and only slightly altered after exposure to other stresses. In contrast, the expression of the *htrA* gene was up-regulated 2.5 fold under the heat stress and 10 fold down-regulation in response to osmotic stress. Furthermore, the results indicate that exposure of *C. jejuni* to environmental stresses did not promote its intracellular survival in *A. castellanii* and the bacterium uses a distinct strategy for phagocytosis which involves recruiting actin for internalization in the absence of PI 3-kinase-mediated signal. Interestingly, the data showed that phago-lysosome maturation may not be the primary factor for intra-amoeba killing of *C. jejuni* and all together the findings suggest that the stress response in *C. jejuni* and its interaction with *A. castellanii* are complex.

In this thesis, several approaches have been used to study the survival and virulence of *Campylobacter* spp. in the environments as well as their interactions with other organisms - protozoa. The results presented in this thesis may contribute to the food and water safety as well as better understand for traditional agriculture practices such as manure storage, fertilization of the soil etc. The results of the study of the interactions between food-borne pathogens and protozoa may

open a possibility to study the possible role of protozoa as a vector or a cause of recent food-borne diseases outbreaks from contaminated fresh food produce such as vegetable and ready to eat foods.

Although it has been shown many interesting results which may help us have a better understanding of mechanisms involved in the survival and virulence of *Campylobacters*, more studies are needed.

As such, the study of the interaction between protozoa and bacterial pathogens from the environments such as fertilized soil, water and animal manures to human foods, specially the consumed raw crops will be a good objective.

10. References

- Abbott, S.L., Waddington, M., Lindquist, D., Ware, J., Cheung, W., Ely, J., and Janda, J.M. (2005) Description of *Campylobacter curvus* and *C. curvus*-Like strains associated with sporadic episodes of bloody gastroenteritis and brainerd's diarrhea. *J Clin Microbiol* **43**: 585-588.
- Abd, H., Johansson, T., Golovliov, I., Sandström, G., and Forsman, M. (2003) Survival and growth of *Francisella tularensis* in *Acanthamoeba castellanii*. *Appl Environ Microbiol* **69**: 600-606.
- Abd, H., Valeru, S.P., Sami, S.M., Saeed, A., Raychaudhuri, S., and Sandström, G. (2010) Interaction between *Vibrio mimicus* and *Acanthamoeba castellanii*. *Environ Microbiol Rep* **2**: 166-171.
- Abee, T., and Wouters, J.A. (1999) Microbial stress response in minimal processing. *Int J Food Microbiol* **50**: 65-91.
- Abram, D.D., and Potter, N.N. (1984) Survival of *Campylobacter jejuni* at different temperatures in broth, beef, chicken and cod supplemented with sodium chloride. *J Food Prot* **47**: 795-800.
- Adékambi, T., Reynaud-Gaubert, M., Greub, G., Gevaudan, M.-J., La Scola, B., Raoult, D., and Drancourt, M. (2004) Amoebal coculture of “*Mycobacterium massiliense*” sp. nov. from the Sputum of a Patient with Hemoptoic Pneumonia. *J Clin Microbiol* **42**: 5493-5501.
- Aksozek, A., McClellan, K., Howard, K., Niederkorn, J.Y., and Alizadeh, H. (2002) Resistance of *Acanthamoeba castellanii* Cysts to Physical, Chemical, and Radiological Conditions. *J Parasitol* **88**: 621-623.
- Akya, A., Pointon, A., and Thomas, C. (2009) Mechanism involved in phagocytosis and killing of *Listeria monocytogenes* by *Acanthamoeba polyphaga*. *Parasitol Res* **105**: 1375-1383.
- Akya, A., Pointon, A., and Thomas, C. (2010) *Listeria monocytogenes* does not survive ingestion by *Acanthamoeba polyphaga*. *Microbiology* **156**: 809-818.

- Allen, K.J., Lepp, D., McKellar, R.C., and Griffiths, M.W. (2008) Examination of Stress and Virulence Gene Expression in *Escherichia coli* O157:H7 Using Targeted Microarray Analysis. *Foodborne Pathog Dis* **5**: 437-447.
- Allos, B.M. (2001) *Campylobacter jejuni* Infections: Update on Emerging Issues and Trends. *Clin Infect Dis* **32**: 1201-1206.
- Allos, B.M., and Blaser, M.J. (1995) *Campylobacter jejuni* and the Expanding Spectrum of Related Infections. *Clin Infect Dis* **20**: 1092-1101.
- Alsam, S., Sissons, J., Jayasekera, S., and Khan, N.A. (2005) Extracellular proteases of *Acanthamoeba castellanii* (encephalitis isolate belonging to T1 genotype) contribute to increased permeability in an in vitro model of the human blood–brain barrier. *J Infect* **51**: 150-156.
- Alter, T., and Scherer, K. (2006) Stress Response of *Campylobacter* spp. and its Role in Food Processing. *J Vet Med Series B* **53**: 351-357.
- Auld, H., MacIver, D., and Klaassen, J. (2004) Heavy rainfall and waterborne disease outbreaks: the walkerton example. *J Toxicol Environ Health, Part A* **67**: 1879-1887.
- Avery, S.V., Harwood, J.L., and Lloyd, D. (1995) Quantification and Characterization of Phagocytosis in the Soil Amoeba *Acanthamoeba castellanii* by Flow Cytometry. *Appl Environ Microbiol* **61**: 1124-1132.
- Axelsson-Olsson, D., Waldenstrom, J., Broman, T., Olsen, B., and Holmberg, M. (2005) Protozoan *Acanthamoeba polyphaga* as a Potential Reservoir for *Campylobacter jejuni*. *Appl Environ Microbiol* **71**: 987-992.
- Axelsson-Olsson, D., Ellström, P., Waldenström, J., Haemig, P.D., Brudin, L., and Olsen, B. (2007) *Acanthamoeba-Campylobacter* Coculture as a Novel Method for Enrichment of *Campylobacter* Species. *Appl Environ Microbiol* **73**: 6864-6869.

- Axelsson-Olsson, D., Olofsson, J., Svensson, L., Griekspoor, P., Waldenström, J., Ellström, P., and Olsen, B. (2010a) Amoebae and algae can prolong the survival of *Campylobacter* species in co-culture. *Exp Parasitol* **126**: 59-64.
- Axelsson-Olsson, D., Svensson, L., Olofsson, J., Salomon, P., Waldenström, J., Ellström, P., and Olsen, B. (2010b) Increase in Acid Tolerance of *Campylobacter jejuni* through Coincubation with Amoebae. *Appl Environ Microbiol* **76**: 4194-4200.
- Baek, K., Vegge, C., and Brondsted, L. (2011a) HtrA chaperone activity contributes to host cell binding in *Campylobacter jejuni*. *Gut Pathogens* **3**: 13.
- Baek, K.T., Vegge, C.S., Skorko-Glonek, J., and Brondsted, L. (2011b) Different Contributions of HtrA Protease and Chaperone Activities to *Campylobacter jejuni* Stress Tolerance and Physiology. *Appl Environ Microbiol* **77**: 57-66.
- Bang, D.D., Birgitte, B., Eva, M., Oslash, Iler, N., Flemming, S. et al. (2004) Detection of Seven Virulence and Toxin Genes of *Campylobacter jejuni* Isolates from Danish Turkeys by PCR and Cytotoxic Distending Toxin Production of the Isolates. *J Food Prot* **67**: 2171-2177.
- Baré, J., Houf, K., Verstraete, T., Vaerewijck, M., and Sabbe, K. (2011) Persistence of Free-Living Protozoan Communities across Rearing Cycles in Commercial Poultry Houses. *Appl Environ Microbiol* **77**: 1763-1769.
- Baré, J., Sabbe, K., Huws, S., Vercauteren, D., Braeckmans, K., Van Gremberghe, I. et al. (2010) Influence of temperature, oxygen and bacterial strain identity on the association of *Campylobacter jejuni* with *Acanthamoeba castellanii*. *FEMS Microbiol Ecol* **74**: 371-381.
- Barker, J., Humphrey, T.J., and Brown, M.W.R. (1999) Survival of *Escherichia coli* 0157 in a soil protozoan: implications for disease. *FEMS Microbiol Let* **173**: 291-295.
- Beery, J.T., Hugdahl, M.B., and Doyle, M.P. (1988) Colonization of gastrointestinal tracts of chicks by *Campylobacter jejuni*. *Appl Environ Microbiol* **54**: 2365-2370.

- Berger, C.N., Sodha, S.V., Shaw, R.K., Griffin, P.M., Pink, D., Hand, P., and Frankel, G. (2010) Fresh fruit and vegetables as vehicles for the transmission of human pathogens. *Environ Microbiol* **12**: 2385-2397.
- Beuchat, L.R. (1996) *Listeria monocytogenes*: incidence on vegetables. *Food Control* **7**: 223-228.
- Beuchat, L.R. (2002) Ecological factors influencing survival and growth of human pathogens on raw fruits and vegetables. *Microb Infect* **4**: 413-423.
- Bhunja, A. (2008) *Foodborne Microbial Pathogens: mechanisms and pathogenesis*. New York: Springer.
- Biswas, D., Itoh, K., and Sasakawa, C. (2000) Uptake pathways of clinical and healthy animal isolates of *Campylobacter jejuni* into INT-407 cells. *FEMS Immunol Med Microbiol* **29**: 203-211.
- Black, R.E., Levine, M.M., Clements, M.L., Hughes, T.P., and Blaser, M.J. (1988) Experimental *Campylobacter jejuni* Infection in Humans. *J Infect Dis* **157**: 472-479.
- Blaser, M.J. (1997) Epidemiologic and Clinical Features of *Campylobacter jejuni* Infections. *J Infect Dis* **176**: S103-S105.
- Boenigk, J., Matz, C., Jürgens, K., and Arndt, H. (2001) The Influence of Preculture Conditions and Food Quality on the Ingestion and Digestion Process of Three Species of Heterotrophic Nanoflagellates. *Microb Ecol* **42**: 168-176.
- Bolton, F.J., Hinchliffe, P.M., Coates, D., and Robertson, L. (1982) A most probable number method for estimating small numbers of campylobacters in water. *J Hyg (Lond)* **89**: 185-190.
- Borazjani, R.N., May, L.L., Noble, J.A., Avery, S.V., and Ahearn, D.G. (2000) Flow Cytometry for Determination of the Efficacy of Contact Lens Disinfecting Solutions against *Acanthamoeba* spp. *Appl Environ Microbiol* **66**: 1057-1061.

- Botteldoorn, N., Van Coillie, E., Piessens, V., Rasschaert, G., Debruyne, L., Heyndrickx, M. et al. (2008) Quantification of *Campylobacter* spp. in chicken carcass rinse by real-time PCR. *J Appl Microbiol* **105**: 1909-1918.
- Bottone, E.J., Pere, A.A., Gordon, R.E., and Qureshi, M.N. (1994) Differential binding capacity and internalisation of bacterial substrates as factors in growth rate of *Acanthamoeba* spp. *J Med Microbiol* **40**: 148-154.
- Brassard, J., Guévremont, É., Gagné, M.-J., and Lamoureux, L. (2011) Simultaneous recovery of bacteria and viruses from contaminated water and spinach by a filtration method. *Int J Food Microbiol* **144**: 565-568.
- Brøndsted, L., Andersen, M.T., Parker, M., Jørgensen, K., and Ingmer, H. (2005) The HtrA Protease of *Campylobacter jejuni* Is Required for Heat and Oxygen Tolerance and for Optimal Interaction with Human Epithelial Cells. *Appl Environ Microbiol* **71**: 3205-3212.
- Buck, J.W., Walcott, R.R., and Beuchat, L.R. (2003). Recent trends in microbiological safety of fruits and vegetables. *Plant Health Progress*. <http://dx.doi.org/10.1094/PHP-2003-0121-01-RV>
- Bui, X.T., Wolff, A., Madsen, M., and Duong Bang, D. (2011a) Fate and survival of *Campylobacter coli* in swine manure at various temperatures. *Front Microbiol* **2**.
- Bui, X.T., Wolff, A., Madsen, M., and Bang, D.D. (2012) Reverse transcriptase real-time PCR for detection and quantification of viable *Campylobacter jejuni* directly from poultry faecal samples. *Res Microbiol* **163**: 64-72.
- Bui, X.T., Winding, A., Qvortrup, K., Wolff, A., Bang, D.D., and Creuzenet, C. (2011b) Survival of *Campylobacter jejuni* in co-culture with *Acanthamoeba castellanii*: role of amoeba-mediated depletion of dissolved oxygen. *Environ Microbiol* doi: 10.1111/j.1462-2920.2011.02655.x.

- Buswell, C.M., Herlihy, Y.M., Keevil, C.W., Marsh, P.D., and Leach, S.A. (1998) Carbon load in aquatic ecosystems affects the diversity and biomass of water biofilm consortia and the persistence of the pathogen *Campylobacter jejuni* within them. *J Appl Microbiol* **85**: 161S-167S.
- Candon, H.L., Allan, B.J., Fraley, C.D., and Gaynor, E.C. (2007a) Polyphosphate Kinase 1 Is a Pathogenesis Determinant in *Campylobacter jejuni*. *J Bacteriol* **189**: 8099-8108.
- Cappelier, J.M., Minet, J., Magras, C., Colwell, R.R., and Federighi, M. (1999) Recovery in embryonated eggs of viable but nonculturable *Campylobacter jejuni* cells and maintenance of ability to adhere to HeLa cells after resuscitation. *Appl Environ Microbiol* **65**: 5154-5157.
- Chaban, B., Ngeleka, M., and Hill, J. (2010) Detection and quantification of 14 *Campylobacter* species in pet dogs reveals an increase in species richness in feces of diarrheic animals. *BMC Microbiology* **10**: 73.
- Champion, O.L., Karlyshev, A.V., Senior, N.J., Woodward, M., La Ragione, R., Howard, S.L. et al. (2010) Insect Infection Model for *Campylobacter jejuni* Reveals That O-methyl Phosphoramidate Has Insecticidal Activity. *J Infect Dis* **201**: 776-782.
- Chenna, R., Sugawara, H., Koike, T., Lopez, R., Gibson, T.J., Higgins, D.G., and Thompson, J.D. (2003) Multiple sequence alignment with the Clustal series of programs. *Nucleic Acids Res* **31**: 3497-3500.
- Chua, K., Gürtler, V., Montgomery, J., Fraenkel, M., Mayall, B.C., and Grayson, M.L. (2007) *Campylobacter insulaenigrae* causing septicaemia and enteritis. *J Med Microbiol* **56**: 1565-1567.
- Cirillo, J.D., Falkow, S., Tompkins, L.S., and Bermudez, L.E. (1997) Interaction of *Mycobacterium avium* with environmental amoebae enhances virulence. *Infect Immun* **65**: 3759-3767.

- Cirillo, J.D., Cirillo, S.L.G., Yan, L., Bermudez, L.E., Falkow, S., and Tompkins, L.S. (1999) Intracellular Growth in *Acanthamoeba castellanii* Affects Monocyte Entry Mechanisms and Enhances Virulence of *Legionella pneumophila*. *Infect Immun* **67**: 4427-4434.
- Clark, C.G., Price, L., Ahmed, R., Woodward, D.L., Melito, P.L., Rodgers, F.G. et al. (2003) Characterization of Waterborne Outbreak-associated *Campylobacter jejuni*, Walkerton, Ontario. *Emerg Infect Dis* **9**: 1232-1241.
- Cools, I., Uyttendaele, M., Cerpentier, J., D'Haese, E., Nelis, H.J., and Debevere, J. (2005) Persistence of *Campylobacter jejuni* on surfaces in a processing environment and on cutting boards. *Let Appl Microbiol* **40**: 418-423.
- Cooper, J.A. (1987) Effects of cytochalasin and phalloidin on actin. *J Cell Biol* **105**: 1473-1478.
- Corry, J.E.L., James, C., James, S.J., and Hinton, M. (1995) *Salmonella*, *Campylobacter* and *Escherichia coli* 0157:H7 decontamination techniques for the future. *Int J Food Microbiol* **28**: 187-196.
- Coutard, F., Pommepuy, M., Loaec, S., and Hervio-Heath, D. (2005) mRNA detection by reverse transcription-PCR for monitoring viability and potential virulence in a pathogenic strain of *Vibrio parahaemolyticus* in viable but nonculturable state. *J Appl Microbiol* **98**: 951-961.
- Crook, P.D., Aguilera, J.F., Threlfall, E.J., O'Brien, S.J., Sigmundsdóttir, G., Wilson, D. et al. (2003) A European outbreak of *Salmonella enterica* serotype Typhimurium definitive phage type 204b in 2000. *Clin Microbiol Infect* **9**: 839-845.
- De Moraes, J., and Alfieri, S.C. (2008) Growth, encystment and survival of *Acanthamoeba castellanii* grazing on different bacteria. *FEMS Microbiol Ecol* **66**: 221-229.
- Debretson, A., Habtemariam, T., Wilson, S., Nganwa, D., and Yehualaeshet, T. (2007) Real-time PCR assay for rapid detection and quantification of *Campylobacter jejuni* on chicken rinses from poultry processing plant. *Mol Cell Probes* **21**: 177-181.

- Debruyne, L., On, S.L.W., De Brandt, E., and Vandamme, P. (2009) Novel *Campylobacter lari*-like bacteria from humans and molluscs: description of *Campylobacter peloridis* sp. nov., *Campylobacter lari* subsp. *concheus* subsp. nov. and *Campylobacter lari* subsp. *lari* subsp. nov. *Int J Syst Evol Microbiol* **59**: 1126-1132.
- Debruyne, L., Broman, T., Bergström, S., Olsen, B., On, S.L.W., and Vandamme, P. (2010a) *Campylobacter subantarcticus* sp. nov., isolated from birds in the sub-Antarctic region. *Int J Syst Evol Microbiol* **60**: 815-819.
- Debruyne, L., Broman, T., Bergström, S., Olsen, B., On, S.L.W., and Vandamme, P. (2010b) *Campylobacter volucris* sp. nov., isolated from black-headed gulls (*Larus ridibundus*). *Int J Syst Evol Microbiol* **60**: 1870-1875.
- Deruiter, P.C., Moore, J.C., Zwart, K.B., Bouwman, L.A., Hassink, J., Bloem, J. et al. (1993) Simulation of nitrogen mineralization in the below ground food webs of 2 winter-wheat fields. *J Appl Ecol* **30**: 95-106.
- Downey, G.P., Botelho, R.J., Butler, J.R., Molyaner, Y., Chien, P., Schreiber, A.D., and Grinstein, S. (1999) Phagosomal Maturation, Acidification, and Inhibition of Bacterial Growth in Nonphagocytic Cells Transfected with FcγRIIA Receptors. *J Biol Chem* **274**: 28436-28444.
- Doyle, M.P., and Roman, D.J. (1982) Response of *Campylobacter jejuni* to sodium chloride. *Appl Environ Microbiol* **43**: 561-565.
- Drozd, M., Gangaiah, D., Liu, Z., and Rajashekara, G. (2011) Contribution of TAT System Translocated PhoX to *Campylobacter jejuni* Phosphate Metabolism and Resilience to Environmental Stresses. *PLoS ONE* **6**: e26336.
- EFSA (2011) EFSA explains zoonotic diseases: Food-borne zoonotic diseases In: EFSA.

- Ekelund, F., and Rønn, R. (1994) Notes on protozoa in agricultural soil with emphasis on heterotrophic flagellates and naked amoebae and their ecology. *FEMS Microbiol Rev* **15**: 321-353.
- El-Etr, S.H., Margolis, J.J., Monack, D., Robison, R.A., Cohen, M., Moore, E., and Rasley, A. (2009) *Francisella tularensis* Type A Strains Cause the Rapid Encystment of *Acanthamoeba castellanii* and Survive in Amoebal Cysts for Three Weeks Postinfection. *Appl Environ Microbiol* **75**: 7488-7500.
- Engberg, J., On, S.L.W., Harrington, C.S., and Gerner-Smidt, P. (2000) Prevalence of *Campylobacter*, *Arcobacter*, *Helicobacter*, and *Sutterella* spp. in Human Fecal Samples as Estimated by a Reevaluation of Isolation Methods for *Campylobacters*. *J Clin Microbiol* **38**: 286-291.
- Essig, A., Heinemann, M., Simnacher, U., and Marre, R. (1997) Infection of *Acanthamoeba castellanii* by *Chlamydia pneumoniae*. *Appl Environ Microbiol* **63**: 1396-1399.
- Etoh, Y., Dewhirst, F.E., Paster, B.J., Yamamoto, A., and Goto, N. (1993) *Campylobacter showae* sp. nov., Isolated from the Human Oral Cavity. *Int J Syst Evol Microbiol* **43**: 631-639.
- Fernández, H., Neto, U.F., and Ogatha, S. (1997) Acute Diarrhea Associated With *Campylobacter jejuni* Subsp. *Doylei* in Sao Paulo, Brazil. *Pediatr Infect Dis J* **16**: 1098-1099.
- Fields, J.A., and Thompson, S.A. (2008) *Campylobacter jejuni* CsrA Mediates Oxidative Stress Responses, Biofilm Formation, and Host Cell Invasion. *J Bacteriol* **190**: 3411-3416.
- Fitzgerald, C., and Nachamkin, I. (2007) *Campylobacter* and *Arcobacter*. In *Manual of clinical microbiology*. Murray, P.R., Baron, E.J., Jorgensen, H., Landry, M.L., and Tenover, M.C. (eds). Washington, DC: American Society for Microbiology, pp. 933-946.
- Flekna, G., Štefanič, P., Wagner, M., Smulders, F.J.M., Možina, S.S., and Hein, I. (2007) Insufficient differentiation of live and dead *Campylobacter jejuni* and *Listeria*

- monocytogenes* cells by ethidium monoazide (EMA) compromises EMA/real-time PCR. *Res Microbiol* **158**: 405-412.
- Foster, G., Holmes, B., Steigerwalt, A.G., Lawson, P.A., Thorne, P., Byrer, D.E. et al. (2004) *Campylobacter insulaenigrae* sp. nov., isolated from marine mammals. *Int J Syst Evol Microbiol* **54**: 2369-2373.
- Friedman, C.R., Neimann, J., Wegener, H.C., and Tauxe, R.V. (2000) *Campylobacter jejuni* infections in the United States and other industrialized nations. In *Campylobacter*. Nachamkin, I., and (ed.), M.J.B. (eds). Washington, DC: ASM Press, pp. p. 121-138.
- Fry, B.N., Feng, S., Chen, Y.-Y., Newell, D.G., Coloe, P.J., and Korolik, V. (2000) The galE Gene of *Campylobacter jejuni* Is Involved in Lipopolysaccharide Synthesis and Virulence. *Infect Immun* **68**: 2594-2601.
- Gajraj, R., Pooransingh, S., Hawker, J.I., and Olowokure, B. (2011) Multiple outbreaks of *Salmonella braenderup* associated with consumption of iceberg lettuce. *Int J Environ Health Res*: 1-6.
- Gangaiah, D., Liu, Z., Arcos, J., Kassem, I.I., Sanad, Y., Torrelles, J.B., and Rajashekara, G. (2010) Polyphosphate Kinase 2: A Novel Determinant of Stress Responses and Pathogenesis in *Campylobacter jejuni*. *PLoS ONE* **5**: e12142.
- Gardner, T.J., Fitzgerald, C., Xavier, C., Klein, R., Pruckler, J., Stroika, S., and McLaughlin, J.B. (2011) Outbreak of Campylobacteriosis Associated With Consumption of Raw Peas. *Clin Infect Dis* **53**: 26-32.
- Gaynor, E.C., Wells, D.H., MacKichan, J.K., and Falkow, S. (2005) The *Campylobacter jejuni* stringent response controls specific stress survival and virulence-associated phenotypes. *Mol Microbiol* **56**: 8-27.

- Gaze, W.H., Burroughs, N., Gallagher, M.P., and Wellington, E.M.H. (2003) Interactions between *Salmonella typhimurium* and *Acanthamoeba polyphaga*, and Observation of a New Mode of Intracellular Growth within Contractile Vacuoles. *Microb Ecol* **46**: 358-369.
- Gebhart, C.J., Murtaugh, M.P., Lin, G.F., and Ward, G.E. (1990) Species-specific DNA probes for *Campylobacter* species isolated from pigs with proliferative enteritis. *Vet Microbiol* **24**: 367-379.
- Gourabathini, P., Brandl, M.T., Redding, K.S., Gunderson, J.H., and Berk, S.G. (2008) Interactions between Food-Borne Pathogens and Protozoa Isolated from Lettuce and Spinach. *Appl Environ Microbiol* **74**: 2518-2525.
- Greub, G., and Raoult, D. (2004) Microorganisms Resistant to Free-Living Amoebae. *Clin Microbiol Rev* **17**: 413-433.
- Greub, G.M.D., and Raoult, D.M.D. (2003) Biocides Currently Used for Bronchoscope Decontamination Are Poorly Effective Against Free-Living Amoebae. *Infect Control Hosp Epidemiol* **24**: 784-786.
- Griffiths, B.S. (1989) Enhanced nitrification in the presence of bacteriophagous protozoa. *Soil Biol Biochem* **21**: 1045-1051.
- Griffiths, B.S., Bonkowski, M., Dobson, G., and Caul, S. (1999) Changes in soil microbial community structure in the presence of microbial-feeding nematodes and protozoa. *Pedobiologia* **43**: 297-304.
- Griffiths, P.L. (1993) Morphological changes of *Campylobacter jejuni* growing in liquid culture. *Let Appl Microbiol* **17**: 152-155.
- Gundogdu, O., Mills, D.C., Elmi, A., Martin, M.J., Wren, B.W., and Dorrell, N. (2011) The *Campylobacter jejuni* Transcriptional Regulator Cj1556 Plays a Role in the Oxidative and

- Aerobic Stress Response and Is Important for Bacterial Survival In Vivo. *J Bacteriol* **193**: 4238-4249.
- Hahn, M.W., and Höfle, M.G. (2001) Grazing of protozoa and its effect on populations of aquatic bacteria. *FEMS Microbiol Ecol* **35**: 113-121.
- Han, X.Y., Tarrand, J.J., and Rice, D.C. (2005) Oral *Campylobacter* Species Involved in Extraoral Abscess: a Report of Three Cases. *J Clin Microbiol* **43**: 2513-2515.
- Hanninen, M.-L., Haajanen, H., Pummi, T., Wermundsen, K., Katila, M.-L., Sarkkinen, H. et al. (2003) Detection and Typing of *Campylobacter jejuni* and *Campylobacter coli* and Analysis of Indicator Organisms in Three Waterborne Outbreaks in Finland. *Appl Environ Microbiol* **69**: 1391-1396.
- Hilbi, H., Weber, S.S., Ragaz, C., Nyfeler, Y., and Urwyler, S. (2007) Environmental predators as models for bacterial pathogenesis. *Environ Microbiol* **9**: 563-575.
- Hong, J., Jung, W.K., Kim, J.M., Kim, S.H., Koo, H.C., Ser, J., and Park, Y.H. (2007) Quantification and Differentiation of *Campylobacter jejuni* and *Campylobacter coli* in Raw Chicken Meats Using a Real-Time PCR Method. *J Food Protect* **70**: 2015-2022.
- Horn, M., Wagner, M., Müller, K.-D., Schmid, E.N., Fritsche, T.R., Schleifer, K.-H., and Michel, R. (2000) *Neochlamydia hartmannellae* gen. nov., sp. nov. (Parachlamydiaceae), an endoparasite of the amoeba *Hartmannella vermiformis*. *Microbiology* **146**: 1231-1239.
- Hu, L., McDaniel, J.P., and Kopecko, D.J. (2006) Signal transduction events involved in human epithelial cell invasion by *Campylobacter jejuni* 81-176. *Microb Pathog* **40**: 91-100.
- Hu, L., Tall, B.D., Curtis, S.K., and Kopecko, D.J. (2008) Enhanced Microscopic Definition of *Campylobacter jejuni* 81-176 Adherence to, Invasion of, Translocation across, and Exocytosis from Polarized Human Intestinal Caco-2 Cells. *Infect Immun* **76**: 5294-5304.
- Hughes, R. (2004) *Campylobacter jejuni* in Guillain-Barré syndrome. *Lancet Neurol* **3**: 644.

- Hughes, R., and Kilvington, S. (2001) Comparison of Hydrogen Peroxide Contact Lens Disinfection Systems and Solutions against *Acanthamoeba polyphaga*. *Antimicrob Agents Chemother* **45**: 2038-2043.
- Huws, S.A., McBain, A.J., and Gilbert, P. (2005) Protozoan grazing and its impact upon population dynamics in biofilm communities. *J Appl Microbiol* **98**: 238-244.
- Huws, S.A., Morley, R.J., Jones, M.V., Brown, M.R.W., and Smith, A.W. (2008) Interactions of some common pathogenic bacteria with *Acanthamoeba polyphaga*. *FEMS Microbiol Letters* **282**: 258-265.
- Inglis, G.D., Kalischuk, L.D., Busz, H.W., and Kastelic, J.P. (2005) Colonization of Cattle Intestines by *Campylobacter jejuni* and *Campylobacter lanienae*. *Appl Environ Microbiol* **71**: 5145-5153.
- Inglis, G.D., Hoar, B.M., Whiteside, D.P., and Morck, D.W. (2007) *Campylobacter canadensis* sp. nov., from captive whooping cranes in Canada. *Int J Syst Evol Microbiol* **57**: 2636-2644.
- Islam, M., Morgan, J., Doyle, M.P., Phatak, S.C., Millner, P., and Jiang, X. (2004) Persistence of *Salmonella enterica* Serovar Typhimurium on Lettuce and Parsley and in Soils on Which They Were Grown in Fields Treated with Contaminated Manure Composts or Irrigation Water. *Foodborne Pathog Dis* **1**: 27-35.
- Jackson, D., Davis, B., Tirado, S., Duggal, M., van Frankenhuyzen, J., Deaville, D. et al. (2009) Survival mechanisms and culturability of *Campylobacter jejuni* under stress conditions. *Antonie van Leeuwenhoek* **96**: 377-394.
- Jay, J.M., Loessner, M.J., and Golden, D.A. (2005) Taxonomy, Role, and Significance of Microorganisms in Foods Modern Food Microbiology. In: Springer US, pp. 13-37.

- Jeon, B., Wang, Y., Hao, H., Barton, Y.-W., and Zhang, Q. (2011) Contribution of CmeG to antibiotic and oxidative stress resistance in *Campylobacter jejuni*. *J Antimicrob Chemother* **66**: 79-85.
- Jin, S., Joe, A., Lynett, J., Hani, E.K., Sherman, P., and Chan, V.L. (2001) JlpA, a novel surface-exposed lipoprotein specific to *Campylobacter jejuni*, mediates adherence to host epithelial cells. *Mol Microbiol* **39**: 1225-1236.
- Josefsen, M.H., Löfström, C., Hansen, T.B., Christensen, L.S., Olsen, J.E., and Hoorfar, J. (2010) Rapid quantification of viable *Campylobacter* bacteria on chicken carcasses, using real-time pcr and propidium monoazide treatment, as a tool for quantitative risk assessment. *Appl Environ Microbiol* **76**: 5097-5104.
- Kamal, N., Dorrell, N., Jagannathan, A., Turner, S.M., Constantinidou, C., Studholme, D.J. et al. (2007) Deletion of a previously uncharacterized flagellar-hook-length control gene *fliK* modulates the σ_{54} -dependent regulon in *Campylobacter jejuni*. *Microbiology* **153**: 3099-3111.
- Kang, H., Loui, C., Clavijo, R.I., Riley, L.W., and Lu, S. (2006) Survival characteristics of *Salmonella enterica* serovar Enteritidis in chicken egg albumen. *Epidemiol Infect* **134**: 967-976.
- Kaur, T., Singh, J., Huffman, M.A., Petrželková, K.J., Taylor, N.S., Xu, S. et al. (2011) *Campylobacter troglodytis* sp. nov., Isolated from Feces of Human-Habituated Wild Chimpanzees (*Pan troglodytes schweinfurthii*) in Tanzania. *Appl Environ Microbiol* **77**: 2366-2373.
- Kelly, D.J. (2001) The physiology and metabolism of *Campylobacter jejuni* and *Helicobacter pylori*. *J Appl Microbiol* **90**: 16S-24S.

- Keramas, G., Bang, D.D., Lund, M., Madsen, M., Bunkenborg, H., Telleman, P., and Christensen, C.B.V. (2004) Use of Culture, PCR Analysis, and DNA Microarrays for Detection of *Campylobacter jejuni* and *Campylobacter coli* from Chicken Feces. *J Clin Microbiol* **42**: 3985-3991.
- Khan, N.A. (2006) Acanthamoeba: biology and increasing importance in human health. *FEMS Microbiol Rev* **30**: 564-595.
- Kilvington, S., and Price, J. (1990) Survival of *Legionella pneumophila* within cysts of *Acanthamoeba polyphaga* following chlorine exposure. *J Appl Microbiol* **68**: 519-525.
- King, C.H., Fields, B.S., Shotts, E.B., Jr, and White, E.H. (1991) Effects of cytochalasin D and methylamine on intracellular growth of *Legionella pneumophila* in amoebae and human monocyte-like cells. *Infect Immun* **59**: 758-763.
- Kjær, J., Olsen, P., Bach, K., Barlebo, H.C., Ingerslev, F., Hansen, M., and Sørensen, B.H. (2007) Leaching of Estrogenic Hormones from Manure-Treated Structured Soils. *Environ Sci Tech* **41**: 3911-3917.
- Klančnik, A., Botteldoorn, N., Herman, L., and Možina, S.S. (2006) Survival and stress induced expression of groEL and rpoD of *Campylobacter jejuni* from different growth phases. *Int J Food Microbiol* **112**: 200-207.
- Klančnik, A., Guzej, B., Jamnik, P., Vučković, D., Abram, M., and Možina, S.S. (2009) Stress response and pathogenic potential of *Campylobacter jejuni* cells exposed to starvation. *Res Microbiol* **160**: 345-352.
- Konkel, M.E., Kim, B.J., Rivera-Amill, V., and Garvis, S.G. (1999) Bacterial secreted proteins are required for the internalization of *Campylobacter jejuni* into cultured mammalian cells. *Mol Microbiol* **32**: 691-701.

- Konkel, M.E., Kim, B.J., Klena, J.D., Young, C.R., and Ziprin, R. (1998) Characterization of the Thermal Stress Response of *Campylobacter jejuni*. *Infect Immun* **66**: 3666-3672.
- Krause-Gruszczynska, M., Van Alphen, L.B., Oyarzabal, O.A., Alter, T., Hänel, I., Schliephake, A. et al. (2007) Expression patterns and role of the CadF protein in *Campylobacter jejuni* and *Campylobacter coli*. *FEMS Microbiol Let* **274**: 9-16.
- Laskowska, E., Kuczyńska-Wiśnik, D., Skórko-Glonek, J., and Taylor, A. (1996) Degradation by proteases Lon, Clp and HtrA, of Escherichia coli proteins aggregated in vivo by heat shock; HtrA protease action in vivo and in vitro. *Mol Microbiol* **22**: 555-571.
- Lastovica, A.J., and Allos, B.M. (2008) Clinical significance of Campylobacter and related species other than *Campylobacter jejuni* and *Campylobacter coli*. In *Campylobacter*. Nachamkin, I., Szymanski, C.M., and Blaser, M.J. (eds). Washington, DC: American Society for Microbiology, pp. 123-149.
- Lawson, A.J., On, S.L., Logan, J.M., and Stanley, J. (2001) *Campylobacter hominis* sp. nov., from the human gastrointestinal tract. *Int J Syst Evol Microbiol* **51**: 651-660.
- Lekfeldt, J.D.S., and Rønn, R. (2008) A common soil flagellate (*Cercomonas* sp.) grows slowly when feeding on the bacterium *Rhodococcus fascians* in isolation, but does not discriminate against it in a mixed culture with *Sphingopyxis witflariensis*. *FEMS Microbiol Ecol* **65**: 113-124.
- Levchenko, A., and Iglesias, P.A. (2002) Models of Eukaryotic Gradient Sensing: Application to Chemotaxis of Amoebae and Neutrophils. *Biophys J* **82**: 50-63.
- Li, S., Dorrell, N., Everest, P., Dougan, G., and Wren, B. (1996) Construction and characterization of a *Yersinia enterocolitica* O:8 high- temperature requirement (htrA) isogenic mutant. *Infect Immun* **64**: 2088-2094.

- Li, Y.-P., Ingmer, H., Madsen, M., and Bang, D. (2008) Cytokine responses in primary chicken embryo intestinal cells infected with *Campylobacter jejuni* strains of human and chicken origin and the expression of bacterial virulence-associated genes. *BMC Microbiology* **8**: 107.
- Lin, S., Gilpin, B., Scholes, P., Podivinsky, E., Klena, J., and Savill, M. (2009) Preliminary development and validation of a real-time reverse transcription PCR assay for the semi-quantification of viable *Campylobacter jejuni* in water samples. *Water Sci Tech* **12**: 3151-3158.
- Lindblom, G.-B., Sjögren, E., Hansson-Westerberg, J., and Kaijser, B. (1995) *Campylobacter upsaliensis*, *C. sputorum sputorum* and *C. concisus* as Common Causes of Diarrhoea in Swedish Children. *Scand J Infect Dis* **27**: 187-188.
- Liu, Y., Wang, C., Fung, C., and Li, X.F. (2010) Quantification of viable but nonculturable *Escherichia coli* O157:H7 by targeting the rpoS mRNA. *Anal Chem* **82**: 2612-2615.
- Livak, K.J., and Schmittgen, T.D. (2001) Analysis of Relative Gene Expression Data Using Real-Time Quantitative PCR and the $2^{-\Delta\Delta CT}$ Method. *Methods* **25**: 402-408.
- Lund, M., Nordentoft, S., Pedersen, K., and Madsen, M. (2004) Detection of *Campylobacter* spp. in chicken fecal samples by real-time PCR. *J Clin Microbiol* **42**: 5125-5132.
- Ly, T.M.C., and Muller, H.E. (1990) Ingested *Listeria monocytogenes* survive and multiply in protozoa. *J Med Microbiol* **33**: 51-54.
- Ma, Y.U.E., Hanning, I., and Slavik, M. (2009) Stress-induced adaptive tolerance response and virulence gene expression in *Campylobacter jejuni*. *J Food Saf* **29**: 126-143.
- Macuch, P.J., and Tanner, A.C.R. (2000) *Campylobacter* Species in Health, Gingivitis, and Periodontitis. *J Den Res* **79**: 785-792.
- Malik-Kale, P., Parker, C.T., and Konkell, M.E. (2008) Culture of *Campylobacter jejuni* with Sodium Deoxycholate Induces Virulence Gene Expression. *J Bacteriol* **190**: 2286-2297.

- Mandal, P.K., Biswas, A.K., Choi, K., and Pal, U.K. (2011) Methods for Rapid Detection of Foodborne Pathogens: An Overview. *American J Food Tech* **6**: 87-102.
- Marciano-Cabral, F., and Cabral, G. (2003) *Acanthamoeba* spp. as agents of disease in humans. *Clin Microbiol Rev* **16**: 273.
- Marolda, C.L., Hauröder, B., John, M.A., Michel, R., and Valvano, M.A. (1999) Intracellular survival and saprophytic growth of isolates from the *Burkholderia cepacia* complex in free-living amoebae. *Microbiology* **145**: 1509-1517.
- Matz, C., and Kjelleberg, S. (2005) Off the hook – how bacteria survive protozoan grazing. *Trends in Microbiology* **13**: 302-307.
- Matz, C., Deines, P., Boenigk, J., Arndt, H., Eberl, L., Kjelleberg, S., and Jürgens, K. (2004) Impact of Violacein-Producing Bacteria on Survival and Feeding of Bacterivorous Nanoflagellates. *Appl Environ Microbiol* **70**: 1593-1599.
- Maurer, J.J. (2006) *The Mythology of PCR: A Warning to the Wise PCR Methods in Foods*: 27-40.
- Mayer-Scholl, A., Averhoff, P., and Zychlinsky, A. (2004) How do neutrophils and pathogens interact? *Curr Opin Microbiol* **7**: 62-66.
- Mbata, T.I. (2005) Poultry meat pathogens and its control. *Int J Food Saf* **7**: 20–28.
- McLaughlin, H., Casey, P., Cotter, J., Gahan, C., and Hill, C. (2011) Factors affecting survival of *Listeria monocytogenes* and *Listeria innocua* in soil samples. *Arch Microbiol* **193**: 775-785.
- Mekalanos, J.J. (1992) Environmental signals controlling expression of virulence determinants in bacteria. *J Bacteriol* **174**: 1-7.
- Mihaljevic, R.R., Sikic, M., Klancnik, A., Brumini, G., Mozina, S.S., and Abram, M. (2007) Environmental stress factors affecting survival and virulence of *Campylobacter jejuni*. *Microb Pathog* **43**: 120-125.

- Moffat, J.F., and Tompkins, L.S. (1992) A quantitative model of intracellular growth of *Legionella pneumophila* in *Acanthamoeba castellanii*. *Infect Immun* **60**: 296-301.
- Molmeret, M., Horn, M., Wagner, M., Santic, M., and Abu Kwaik, Y. (2005) Amoebae as Training Grounds for Intracellular Bacterial Pathogens. *Appl Environ Microbiol* **71**: 20-28.
- Monteville, M.R., Yoon, J.E., and Konkel, M.E. (2003) Maximal adherence and invasion of INT 407 cells by *Campylobacter jejuni* requires the CadF outer-membrane protein and microfilament reorganization. *Microbiology* **149**: 153-165.
- Moore, J.E. (2001) Bacterial dormancy in *Campylobacter*: abstract theory or cause for concern? *Int J Food Sci Tech* **36**: 593-600.
- Moreno, A. M., (2008) Understanding bacteria-protozoa interactions: from grazing resistance mechanisms to carbon flow in bacteria-protozoa food webs. PhD thesis.
- Murphy, C., Carroll, C., and Jordan, K.N. (2003) Induction of an adaptive tolerance response in the foodborne pathogen, *Campylobacter jejuni*. *FEMS Microbiol Let* **223**: 89-93.
- Murphy, C., Carroll, C., and Jordan, K.N. (2006) Environmental survival mechanisms of the foodborne pathogen *Campylobacter jejuni*. *J Appl Microbiol* **100**: 623-632.
- Nachamkin, I., Szymanski, C.M., and Blaser, M.J. (2008) *Campylobacter*: ASM Press.
- Nakari, U. M., (2011) Identification and Epidemiological Typing of *Campylobacter* Strains Isolated from Patients in Finland. PhD thesis.
- Newell, D.G., Koopmans, M., Verhoef, L., Duizer, E., Aidara-Kane, A., Sprong, H. et al. (2010) Food-borne diseases - The challenges of 20years ago still persist while new ones continue to emerge. *Int J Food Microbiol* **139**: S3-S15.
- Newton, J.M., and Surawicz, C.M. (2011) Infectious Gastroenteritis and Colitis Diarrhea. In: Guandalini, S., and Vaziri, H. (eds): Humana Press, pp. 33-59.
- Nguyen, H. (2011) *Acanthamoeba-Campylobacter* interaction. Master thesis.

- Nicholson, F.A., Groves, S.J., and Chambers, B.J. (2005) Pathogen survival during livestock manure storage and following land application. *Bio Tech* **96**: 135-143.
- Nielsen, A.M., Spanjers, H., and Volcke, E.I.P. (2008) Calculating pH in pig manure taking into account ionic strength. *Water Sci Tech* **57**: 1785-1790.
- Oelschlaeger, T.A., Guerry, P., and Kopecko, D.J. (1993) Unusual microtubule-dependent endocytosis mechanisms triggered by *Campylobacter jejuni* and *Citrobacter freundii*. *Proc Natl Acad Sci U S A*. **90**: 6884-6888.
- Ogden, I.D., Dallas, J.F., MacRae, M., Rotariu, O., Reay, K.W., Leitch, M. et al. (2009) *Campylobacter* Excreted into the Environment by Animal Sources: Prevalence, Concentration Shed, and Host Association. *Foodborne Pathog Dis* **6**: 1161-1170.
- Okoli, A.S., Wadstrom, T., and Mendz, G.L. (2007) MiniReview: Bioinformatic study of bile responses in Campylobacterales. *FEMS Immunol Med Microbiol* **49**: 101-123.
- Oliver, S.P., Jayarao, B.M., and Almeida, R.A. (2005) Foodborne Pathogens in Milk and the Dairy Farm Environment: Food Safety and Public Health Implications. *Foodborne Pathog Dis* **2**: 115-129.
- On, S.L.W. (2001) Taxonomy of *Campylobacter*, *Arcobacter*, *Helicobacter* and related bacteria: current status, future prospects and immediate concerns. *J Appl Microbiol* **90**: 1S-15S.
- On, S.L.W., Atabay, H.I., Corry, J.E.L., Harrington, C.S., and Vandamme, P. (1998) Emended description of *Campylobacter sputorum* and revision of its infrasubspecific (biovar) divisions, including *C. sputorum* biovar *paraureolyticus*, a urease-producing variant from cattle and humans. *Int J Syst Bacteriol* **48**: 195-206.
- Pakalniskiene, J., Falkenhorst, G., Lisby, M., Madsen, S.B., Olsen, K.E.P., Nielsen, E.M. et al. (2009) A foodborne outbreak of enterotoxigenic *E. coli* and *Salmonella* Anatum infection after a high-school dinner in Denmark, November 2006. *Epidemiol Infect* **137**: 396-401.

- Palyada, K., Sun, Y.-Q., Flint, A., Butcher, J., Naikare, H., and Stintzi, A. (2009) Characterization of the oxidative stress stimulon and PerR regulon of *Campylobacter jejuni*. *BMC Genomics* **10**: 481.
- Park, S.F. (2002) The physiology of *Campylobacter* species and its relevance to their role as foodborne pathogens. *Int J Food Microbiol* **74**: 177-188.
- Parry, J.D. (2004) Protozoan Grazing of Freshwater Biofilms. In *Advances in Applied Microbiology*: Academic Press, pp. 167-196.
- Patterson, D.M., Jackson, F., Huntley, J.F., Stevenson, L.M., Jones, D.G., Jackson, E., and Russel, A.J.F. (1996) Studies on caprine responsiveness to nematodiasis: Segregation of male goats into responders and non-responders. *Int J Parasitol* **26**: 187-194.
- Pedersen, A., Nybroe, O., Winding, A., Ekelund, F., and Bjørnlund, L. (2009) Bacterial Feeders, the Nematode *Caenorhabditis elegans* and the Flagellate *Cercomonas longicauda*, have different Effects on Outcome of Competition among the Pseudomonas Biocontrol Strains CHA0 and DSS73. *Microbl Ecol* **57**: 501-509.
- Pedersen, A.L., Winding, A., Altenburger, A., and Ekelund, F. (2011) Protozoan growth rates on secondary-metabolite-producing Pseudomonas spp. correlate with high-level protozoan taxonomy. *FEMS Microbiol Let* **316**: 16-22.
- Pesanti, E.L. (1978) Suramin effects on macrophage phagolysosome formation and antimicrobial activity. *Infect Immun* **20**: 503-511.
- Phongsisay, V., Perera, V.N., and Fry, B.N. (2007) Expression of the *htrB* gene is essential for responsiveness of *Salmonella typhimurium* and *Campylobacter jejuni* to harsh environments. *Microbiology* **153**: 254-262.

- Pires, S.M., Evers, E.G., van Pelt, W., Ayers, T., Scallan, E., Angulo, F.J. et al. (2009) Attributing the Human Disease Burden of Foodborne Infections to Specific Sources *Foodborne Pathog Dis* **6**: 417-424.
- Pogačar, M.Š., Klančnik, A., Možina, S.S., and Cencič, A. (2009a) Attachment, Invasion, and Translocation of *Campylobacter jejuni* in Pig Small-Intestinal Epithelial Cells. *Foodborne Pathog Dis* **7**: 589-595.
- Pogačar, M.Š., Roberta, R.M., Anja, K., Gordana, B., Maja, A., and Sonja, S.M. (2009b) Survival of stress exposed *Campylobacter jejuni* in the murine macrophage J774 cell line. *Int J Food Microbiol* **129**: 68-73.
- Pope, J.E., Krizova, A., Garg, A.X., Thiessen-Philbrook, H., and Ouimet, J.M. (2007) *Campylobacter* Reactive Arthritis: A Systematic Review. *Seminars in Arthritis and Rheumatism* **37**: 48-55.
- Ramabu, S.S., Boxall, N.S., Madie, P., and Fenwick, S.G. (2004) Some potential sources for transmission of *Campylobacter jejuni* to broiler chickens. *Let Appl Microbiol* **39**: 252-256.
- Reezal, A., McNeil, B., and Anderson, J.G. (1998) Effect of Low-Osmolality Nutrient Media on Growth and Culturability of *Campylobacter* Species. *Appl Environ Microbiol* **64**: 4643-4649.
- Ridley, A.M., Allen, V.M., Sharma, M., Harris, J.A., and Newell, D.G. (2008) Real-Time PCR Approach for Detection of Environmental Sources of *Campylobacter* Strains Colonizing Broiler Flocks. *Appl Environ Microbiol* **74**: 2492-2504.
- Rijpens, N., Jannes, G., and Herman, L. (2002) Messenger RNA-based RT-PCR detection of viable *Salmonella*. *Int Dairy J* **12**: 233-238.
- Robinson, D.A. (1981) Infective dose of *Campylobacter jejuni* in milk. *BMJ* **282**: 1584-1584.
- Rodríguez-Zaragoza, S. (1994) Ecology of Free-Living Amoebae. *Crit Rev Microbiol* **20**: 225-241.

- Rohr, U., Weber, S., Michel, R., Selenka, F., and Wilhelm, M. (1998) Comparison of Free-Living Amoebae in Hot Water Systems of Hospitals with Isolates from Moist Sanitary Areas by Identifying Genera and Determining Temperature Tolerance. *Appl Environ Microbiol* **64**: 1822-1824.
- Rollins, D.M., and Colwell, R.R. (1986) Viable but nonculturable stage of *Campylobacter jejuni* and its role in survival in the natural aquatic environment. *Appl Environ Microbiol* **52**: 531-538.
- Ronn, R., McCaig, A.E., Griffiths, B.S., and Prosser, J.I. (2002) Impact of protozoan grazing on bacterial community structure in soil microcosms. *Appl Environ Microbiol* **68**: 6094-6105.
- Rönner, A.-C., and Lindmark, H. (2007) Quantitative Detection of *Campylobacter jejuni* on Fresh Chicken Carcasses by Real-Time PCR. *J Food Protect* **70**: 1373-1378.
- Rosenquist, H., Bengtsson, A., and Hansen, T.B. (2007) A collaborative study on a Nordic standard protocol for detection and enumeration of thermotolerant *Campylobacter* in food (NMKL 119, 3. Ed., 2007). *Int J Food Microbiol* **118**: 201-213.
- Rossi, M., Debruyne, L., Zanoni, R.G., Manfreda, G., Revez, J., and Vandamme, P. (2009) *Campylobacter avium* sp. nov., a hippurate-positive species isolated from poultry. *Int J Syst Evol Microbiol* **59**: 2364-2369.
- Rowbotham, T. (1980) Preliminary report on the pathogenicity of *Legionella pneumophila* for freshwater and soil amoebae. *J Clin Pathol* **33**: 1179-1183.
- Rudi, K., Høidal, H.K., Katla, T., Johansen, B.K., Nordal, J., and Jakobsen, K.S. (2004) Direct Real-Time PCR Quantification of *Campylobacter jejuni* in Chicken Fecal and Cecal Samples by Integrated Cell Concentration and DNA Purification. *Appl Environ Microbiol* **70**: 790-797.

- Sagarzazu, N., Cebrián, G., Condón, S., Mackey, B., and Mañas, P. (2010) High hydrostatic pressure resistance of *Campylobacter jejuni* after different sublethal stresses. *J Appl Microbiol* **109**: 146-155.
- Sahin, O., Luo, N., Huang, S., and Zhang, Q. (2003) Effect of Campylobacter-Specific Maternal Antibodies on *Campylobacter jejuni* Colonization in Young Chickens. *Appl Environ Microbiol* **69**: 5372-5379.
- Sahin, O., Zhang, Q., Meitzler, J.C., Harr, B.S., Morishita, T.Y., and Mohan, R. (2001) Prevalence, Antigenic Specificity, and Bactericidal Activity of Poultry Anti-Campylobacter Maternal Antibodies. *Appl Environ Microbiol* **67**: 3951-3957.
- Sasaki, Y., Fujisawa, T., Ogikubo, K., Ohzono, T., Ishihara, K., and Takahashi, T. (2003) Characterization of *Campylobacter lanienae* from pig feces. *J Vet Med Sci* **65**: 129-131.
- Scallan, E., Griffin, P.M., Angulo, F.J., Tauxe, R.V., and Hoekstra, R.M. (2011) Foodborne Illness Acquired in the United States-Unspecified Agents. *Emerg Infect Dis* **17**: 16-22.
- Schoenen, D. (2002) Role of disinfection in suppressing the spread of pathogens with drinking water: possibilities and limitations. *Water Research* **36**: 3874-3888.
- Schuster, C.J., Ellis, A.G., Robertson, W.J., Charron, D.F., Aramini, J.J., Marshall, B.J., and Medeiros, D.T. (2005) Infectious disease outbreaks related to drinking water in Canada, 1974-2001. *Can J Public Health* **96**: 254-258.
- Schuster, F.L. (2002) Cultivation of Pathogenic and Opportunistic Free-Living Amebas. *Clin Microbiol Rev* **15**: 342-354.
- Schuster, F.L., and Visvesvara, G.S. (2004) Free-living amoebae as opportunistic and non-opportunistic pathogens of humans and animals. *Int J Parasitol* **34**: 1001-1027.
- Shanker, S., Lee, A., and Sorrell, T.C. (1986) *Campylobacter jejuni* in Broilers: The Role of Vertical Transmission. *J Hyg* **96**: 153-159.

- Sheridan, G.E.C., Masters, C.I., Shallcross, J.A., and Mackey, B.M. (1998) Detection of mRNA by reverse transcription-PCR as indicator of viability in *Escherichia coli* cells. *Appl Environ Microbiol* **64**: 1313-1318.
- Sherr, B.F., Sherr, E.B., and Fallon, R.D. (1987) Use of Monodispersed, Fluorescently Labeled Bacteria to Estimate In Situ Protozoan Bacterivory. *Appl Environ Microbiol* **53**: 958-965.
- Skirrow, M.B., Jones, D.M., Sutcliffe, E., and Benjamin, J. (1993) *Campylobacter* bacteraemia in England and Wales, 1981-91. *Epidemiol Infect* **110**: 567-573.
- Snelling, W., Stern, N., Lowery, C., Moore, J., Gibbons, E., Baker, C., and Dooley, J. (2008) Colonization of broilers by *Campylobacter jejuni* internalized within *Acanthamoeba castellanii*. *Arch Microbiol* **189**: 175-179.
- Snelling, W.J., McKenna, J.P., Lecky, D.M., and Dooley, J.S.G. (2005a) Survival of *Campylobacter jejuni* in Waterborne Protozoa. *Appl Environ Microbiol* **71**: 5560-5571.
- Snelling, W.J., Moore, J.E., McKenna, J.P., Lecky, D.M., and Dooley, J.S.G. (2006) Bacterial-protozoa interactions; an update on the role these phenomena play towards human illness. *Microb Infect* **8**: 578-587.
- Spiller, R.C. (2007) Role of infection in irritable bowel syndrome. *J Gastroenterol* **42**: 41-47.
- Sproston, E.L., Ogden, I.D., MacRae, M., Forbes, K.J., Dallas, J.F., Sheppard, S.K. et al. (2010) Multi-locus sequence types of *Campylobacter* carried by flies and slugs acquired from local ruminant faeces. *J Appl Microbiol* **109**: 829-838.
- Stanley, J., Burnens, A.P., Linton, D., On, S.L.W., Costas, M., and Owen, R.J. (1992) *Campylobacter helveticus* sp. nov., a new thermophilic species from domestic animals: characterization, and cloning of a species-specific DNA probe. *J General Microbiol* **138**: 2293-2303.

- Steele, T.W., and Owen, R.J. (1988) NOTES: *Campylobacter jejuni* subsp. *doylei* subsp. nov., a Subspecies of Nitrate-Negative Campylobacters Isolated from Human Clinical Specimens. *Int J Syst Bacteriol* **38**: 316-318.
- Stern, N.J., Robach, M.C., Cox, N.A., and Musgrove, M.T. (2002) Effect of Drinking Water Chlorination on *Campylobacter* spp. Colonization of Broilers. *Avian Dis* **46**: 401-404.
- Stintzi, A. (2003) Gene Expression Profile of *Campylobacter jejuni* in Response to Growth Temperature Variation. *J Bacteriol* **185**: 2009-2016.
- Storz, G., and Zheng, M. (2000) *Bacterial Stress responses*. Washington, D.C: ASM Press.
- Styrt, B., and Klempner, M.S. (1988) Effects of pH on killing of *Staphylococcus aureus* and *Escherichia coli* by constituents of the neutrophil phagolysosome. *J Med Microbiol* **25**: 101-107.
- Tanner, A.C.R., Listgarten, M.A., and Ebersole, J.L. (1984) *Wolinella curva* sp. nov.: “*Vibrio succinogenes*” of Human Origin. *Int J Syst Bacteriol* **34**: 275-282.
- Tanner, A.C.R., Badger, S., Lai, C.-H., Listgarten, M.A., Visconti, R.A., and Socransky, S.S. (1981) *Wolinella* gen. nov., *Wolinella succinogenes* (*Vibrio succinogenes* Wolin et al.) comb. nov., and Description of *Bacteroides gracilis* sp. nov., *Wolinella recta* sp. nov., *Campylobacter concisus* sp. nov., and *Eikenella corrodens* from Humans with Periodontal Disease. *Int J Syst Bacteriol* **31**: 432-445.
- Templeton, J.M., De Jong, A.J., Blackall, P.J., and Mifflin, J.K. (2006) Survival of *Campylobacter* spp. in Darkling Beetles (*Alphitobius diaperinus*) and Their Larvae in Australia. *Appl Environ Microbiol* **72**: 7909-7911.
- Thies, F.L., Karch, H., Hartung, H.-P., and Giegerich, G. (1999) Cloning and Expression of the *dnaK* Gene of *Campylobacter jejuni* and Antigenicity of Heat Shock Protein 70. *Infect Immun* **67**: 1194-1200.

- Thom, S., Warhurst, D., and Drasar, B.S. (1992) Association of *Vibrio cholerae* with fresh water amoebae. *J Med Microbiol* **36**: 303-306.
- Thomas, C., Hill, D.J., and Mabey, M. (1999) Evaluation of the effect of temperature and nutrients on the survival of *Campylobacter* spp. in water microcosms. *J Appl Microbiol* **86**: 1024-1032.
- Thomas, C., Hill, D., and Mabey, M. (2002) Culturability, injury and morphological dynamics of thermophilic *Campylobacter* spp. within a laboratory-based aquatic model system. *J Applied Microbiol* **92**: 433-442.
- Thomas, V., and McDonnell, G. (2007) Relationship between mycobacteria and amoebae: ecological and epidemiological concerns. *Let Appl Microbiol* **45**: 349-357.
- Thomas, V., Loret, J.-F., Jousset, M., and Greub, G. (2008) Biodiversity of amoebae and amoebae-resisting bacteria in a drinking water treatment plant. *Environ Microbiol* **10**: 2728-2745.
- Thomas, V., McDonnell, G., Denyer, S.P., and Maillard, J.-Y. (2010) Free-living amoebae and their intracellular pathogenic microorganisms: risks for water quality. *FEMS Microbiol Rev* **34**: 231-259.
- Vaerewijck, M.J.M., Sabbe, K., Baré, J., and Houf, K. (2011) Occurrence and diversity of free-living protozoa on butterhead lettuce. *Int J Food Microbiol* **147**: 105-111.
- Valasek, M.A., and Repa, J.J. (2005) The power of real-time PCR. *American J Physiol - Adv Physiol Edu* **29**: 151-159.
- Van Dyke, M.I., Morton, V.K., McLellan, N.L., and Huck, P.M. (2010) The occurrence of *Campylobacter* in river water and waterfowl within a watershed in southern Ontario, Canada. *J Appl Microbiol* **109**: 1053-1066.

- van Vliet, A.H.M., Baillon, M.-L.A., Penn, C.W., and Ketley, J.M. (1999) *Campylobacter jejuni* Contains Two Fur Homologs: Characterization of Iron-Responsive Regulation of Peroxide Stress Defense Genes by the PerR Repressor. *J Bacteriol* **181**: 6371-6376.
- van Vliet, A.H.M., Ketley, J.M., Park, S.F., and Penn, C.W. (2002) The role of iron in *Campylobacter* gene regulation, metabolism and oxidative stress defense. *FEMS Microbiol Rev* **26**: 173-186.
- Vandamme, P., Falsen, E., Rossau, R., Hoste, B., Segers, P., Tytgat, R., and De Ley, J. (1991) Revision of *Campylobacter*, *Helicobacter*, and *Wolinella* Taxonomy: Emendation of Generic Descriptions and Proposal of *Arcobacter* gen. nov. *Int J Syst Bacteriol* **41**: 88-103.
- Vandamme, P., Daneshvar, M.I., Dewhirst, F.E., Paster, B.J., Kersters, K., Goossens, H., and Moss, C.W. (1995) Chemotaxonomic Analyses of *Bacteroides gracilis* and *Bacteroides ureolyticus* and Reclassification of *B. gracilis* as *Campylobacter gracilis* comb. nov. *Int J Syst Bacteriol* **45**: 145-152.
- Velusamy, V., Arshak, K., Korostynska, O., Oliwa, K., and Adley, C. (2010) An overview of foodborne pathogen detection: In the perspective of biosensors. *Biotechnology Advances* **28**: 232-254.
- Verhagen, F.J.M., Duyts, H., and Laanbroek, H.J. (1993) Effects of Grazing by Flagellates on Competition for Ammonium Between Nitrifying and Heterotrophic Bacteria in Soil Columns. *Appl Environ Microbiol* **59**: 2099-2106.
- Wales, A.D., Carrique-Mas, J.J., Rankin, M., Bell, B., Thind, B.B., and Davies, R.H. (2010) Review of the Carriage of Zoonotic Bacteria by Arthropods, with Special Reference to *Salmonella* in Mites, Flies and Litter Beetles. *Zoonoses and Public Health* **57**: 299-314.

- Wassenaar, T.M., Engelskirchen, M., Park, S., and Lastovica, A. (1997) Differential uptake and killing potential of *Campylobacter jejuni* by human peripheral monocytes/macrophages. *Med Microbiol Immunol* **186**: 139-144.
- Watson, R.O., and Galán, J.E. (2008) *Campylobacter jejuni* Survives within Epithelial Cells by Avoiding Delivery to Lysosomes. *PLoS Pathog* **4**: e14.
- Weidner, E., and Sibley, L.D. (1985) Phagocytized Intracellular Microsporidian Blocks Phagosome Acidification and Phagosome-Lysosome Fusion. *J Eu Microbiol* **32**: 311-317.
- WHO (2007). Food safety & food-borne illness. fact sheet no. 237 (reviewed March 2007)
- Wiedmann, M., and Zhang, W. (2011) *Genomics of Foodborne Bacterial Pathogens*. New York: Springer New York.
- Wildschutte, H., and Lawrence, J.G. (2007) Differential Salmonella survival against communities of intestinal amoebae. *Microbiology* **153**: 1781-1789.
- Wolffs, P., Norling, B., and Rådström, P. (2005) Risk assessment of false-positive quantitative real-time PCR results in food, due to detection of DNA originating from dead cells. *J Microbiol Methods* **60**: 315-323.
- Wooldridge, K.G., Williams, P.H., and Ketley, J.M. (1996) Host signal transduction and endocytosis of *Campylobacter jejuni*. *Microb Pathog* **21**: 299-305.
- Xinyao, L., Miao, S., Yonghong, L., Yin, G., Zhongkai, Z., Donghui, W. et al. (2006) Feeding Characteristics of an Amoeba Lobosea Naegleria Grazing Upon Cyanobacteria: Food Selection, Ingestion and Digestion Progress. *Microb Ecol* **51**: 315-325.
- Young, C.R., Ziprin, R.L., Hume, M.E., and Stanker, L.H. (1999) Dose Response and Organ Invasion of Day-of-Hatch Leghorn Chicks by Different Isolates of *Campylobacter jejuni*. *Avian Dis* **43**: 763-767.

- Young, K.T., Davis, L.M., and DiRita, V.J. (2007) *Campylobacter jejuni*: molecular biology and pathogenesis. *Nat Rev Micro* **5**: 665-679.
- Yuki, N. (2001) Infectious origins of, and molecular mimicry in, Guillain-Barré and Fisher syndromes. *Lancet Infect Dis* **1**: 29-37.
- Zanetti, S., Fiori, P.L., Pinna, A., Usai, S., Carta, F., and Fadda, G. (1995) Susceptibility of *Acanthamoeba castellanii* to contact lens disinfecting solutions. *Anti Agents Chemother* **39**: 1596-1598.
- Zanoni, R.G., Debruyne, L., Rossi, M., Revez, J., and Vandamme, P. (2009) *Campylobacter cuniculorum* sp. nov., from rabbits. *Int J Sys Evol Microbiol* **59**: 1666-1671.
- Zhou, X., Elmore, J., and Call, D.R. (2007) Interactions between the environmental pathogen *Listeria monocytogenes* and a free-living protozoan (*Acanthamoeba castellanii*). *Environ Microbiol* **9**: 913-922.
- Ziprin, R.L., Young, C.R., Byrd, J.A., Stanker, L.H., Hume, M.E., Gray, S.A. et al. (2001) Role of *Campylobacter jejuni* Potential Virulence Genes in Cecal Colonization. *Avian Dis* **45**: 549-557.