

Technical University of Denmark



Super-energy wrap-up model for renovation of standard wooden houses in Greenland?

Bjarløv, Søren Peter; Vladyková, Petra

Published in:

Proceedings of the 7th International Cold Climate HVAC Conference

Publication date:

2012

[Link back to DTU Orbit](#)

Citation (APA):

Bjarløv, S. P., & Vladyková, P. (2012). Super-energy wrap-up model for renovation of standard wooden houses in Greenland? In Proceedings of the 7th International Cold Climate HVAC Conference

DTU Library

Technical Information Center of Denmark

General rights

Copyright and moral rights for the publications made accessible in the public portal are retained by the authors and/or other copyright owners and it is a condition of accessing publications that users recognise and abide by the legal requirements associated with these rights.

- Users may download and print one copy of any publication from the public portal for the purpose of private study or research.
- You may not further distribute the material or use it for any profit-making activity or commercial gain
- You may freely distribute the URL identifying the publication in the public portal

If you believe that this document breaches copyright please contact us providing details, and we will remove access to the work immediately and investigate your claim.

Super-energy wrap-up model for renovation of standard wooden houses in Greenland?

Søren Peter Bjarløv, Associate Professor

Petra Vladykova, PhD

ABSTRACT .

This paper is based on the developed theoretical practice of super-insulation solution for renovation of existing standard wooden houses in Greenland built from 1950s until 2006, more than half the building stock in Arctic Greenland. From various perspectives, the wrap-up system is evaluated as a robust building renovation method with focus on applying the membrane for air tightness with a minimum of risk of leakage, high level of insulation with very few thermal bridges, focus on fire protection by using insulation material of mineral wool and high attention on solving details in the building envelope. This interesting wrap-up and package solution can easily be applied to many standard wooden houses in Greenland, but also to wooden houses across the Arctic regions. Linking all these aspects lead to interesting findings about high energy savings, reduction of oil usage and decrease of greenhouse gas emissions in retrofitting of Arctic buildings.

INTRODUCTION

This paper describes a detailed solution of turning an existing house, poorly insulated and with little airtightness, into a super low energy house with a total wrap-up of the building including walls, roof and deck above the crawl space. It is based on the developed theoretical model of super-insulation solution for renovation of standard wooden houses in Greenland (Bjarløv and Vladykova, 2011). Using extensive measurement data from the original and super-insulated houses, the wrap-up model for energy renovation is developed as a holistic solution. The paper deals with detailing the theoretical model into a feasible and useful energy renovation solution for the wooden houses in Greenland. From various perspectives, the method is evaluated as a robust building renovation method with focus on applying the membrane for air tightness with a minimum of risk of leakage, high level of insulation with very few thermal bridges, focus on fire protection due to the dense situated houses by using insulation material of mineral wool, and high attention on solving details in the building envelope. The renovation is carried out without reallocating the inhabitants during the process.

The overall objective of the paper lies in its outline of a systematic method of energy renovation using standardized packages for the renovation of more than half of the housing stock in Greenland. The building method is significant in the number of houses it applies to, and in the way it offers a very good technical solution where new air tightness and vapour barrier and the high level of insulation are added from the outside on the existing cladding. The renovation solution preserves the architectural expression of the houses and the originality of the work is based on the reuse of packages solutions based on the common methods of house construction and implementation in Greenland.

Adding external insulation to buildings is not a new invention. During the 1980s the external insulation of 50 mm (1.97 inches respectively) was added to many houses in Greenland due to the oil crisis at that time, but no airtightness was

Søren Peter Bjarløv is an Associate Professor in the Department of Civil Engineering, Technical University of Denmark, Lyngby, Denmark.
Petra Vladykova is a Project Manager at Swegon AB, Gothenburg, Sweden.

applied, therefore the gain was very small. Adding rigid insulation externally to the roof plate is also very common and well documented. The adding of external insulation outside an airtight membrane placed outside the cladding is described in a research report (Ueno, 2010) in which the findings from three residential projects completed with exterior foam insulating sheathing are described.

Cold Climate Housing and Research Center (CCHRC, 2007) in Alaska has experimented with a super energy wrap-up system for walls in new buildings, where the vapour barrier is placed at the exterior of the wooden framework covered by exterior foam insulating sheathing. In (Craven and Garber-Slaght, 2010; Craven and Garber-Slaght, 2012) the experimental results show that it is possible to keep the moisture in the original cladding under the level of condensation risk if the insulation layer outside the exterior moisture membrane is around and above 2/3 of the total resistance of insulation with outdoor temperatures down to $-40^{\circ}\text{C}/\text{F}$.

THE GREENLANDIC WOODEN RESIDENTIAL HOUSES

Existing residential buildings, built from 1950s until 2006, more than half the building stock in Arctic Greenland, often have problems with draught and uncomfortably low temperatures in the interior due to lack of insufficient thermal insulation and airtight properties of the building envelope and the properties of commonly used technical systems. The standard wooden houses provide low thermal comfort and poor indoor air quality, and have high energy consumption and high greenhouse gas emission (GHG).

The standard family detached and semi-detached wooden houses in Greenland are basically built the same way (Figure 1). The walls are constructed with a wooden framework with gypsum plate inside, insulation and painted wooden cladding outside. The roof is a pitched roof covered with roof paper and the foundation stands on the rock and form a crawl space under the ground floor. The houses are spread all over Greenland and these spectacular standard wooden houses represent the culture heritage of the Greenlandic population. Out of 22,075 (1.1.2007) buildings across Greenland, there are approximately 11,632 (1.1.2007) detached and semi-detached wooden houses with an average floor area of $65\text{ m}^2/700\text{ ft}^2$ and a documented space heating consumption of up to $381\text{ kWh}/(\text{m}^2\cdot\text{a})$ ($120,800\text{ Btu}/\text{ft}^2\cdot\text{a}$ respectively), i.e. up to 2,200 litres of oil per year or 581 gallons of oil per year respectively (Bjarlöv and Vladykova, 2011).



Figure 1 Standard wooden family houses in Greenland (type 18D).

METHODOLOGY

Methodology of this paper focuses on a holistic solution for energy renovation of wooden standard houses in Greenland. As an experimental house is used the standard wooden house of type 18D (built in 1962, floor area of 63 m^2 or 678 ft^2 respectively, a pair of semi-detached houses) (Figure 1) located in Sisimiut (latitude 66.9°N and longitude 53.6°W , annual mean temperature $-3.9^{\circ}\text{C}/25.0^{\circ}\text{C}$, outdoor design temperature $-30^{\circ}\text{C}/-22^{\circ}\text{F}$ and heating degree hours $209\text{ kWh}/\text{a}$ with $T_{\text{base}} = 20.0^{\circ}\text{C}/68\text{ F}$ or respectively $8,700$ heating degree days). The approach considers the detailed measurement data

from the investigations of the buildings (Bjarlöv and Vladykova, 2011), the information obtained about the original package solution and detailed planning and documentation. Keeping the focus on good solution for low energy demand and good indoor air quality, the method is evaluated as a building method with aim on very good building qualities developed as a durable solution for the following parts of the building envelope.

A general review of the houses was carried out in August 2011 based on studies of the original descriptions and drawings of the house (Bjarlöv S.P. and Vladykova P. 2011; Vladykova P. and Bjarlöv S.P. 2012). A visual inspection was used to examine and compare the built house with the drawings and description and a detailed measurement of the houses was carried out. The state of the structure and the cladding was determined. The load carrying structure was investigated and calculated for the extra weight from the wrap-up system. Suitable vapour barriers chosen by prioritizing durability, permeability and adaptability. The semi-rigid mineral wool is screwed into the existing structure and creates a new framework without thermal bridges.

A comprehensive drawings and description material (Silins U. and Vasilevskis S. 2011) was produced including the drawings and description in order to be able to draw up a complete list of materials due to the long distances between the building site and the building material supplier. But also in order to solving all details and giving the builder a chance to avoid faults and mistakes. Moreover, the benefits of the package solution are discussed such as energy savings, greenhouse emissions, architectural expression and cultural heritage of Greenland. Linking all these issues leads to interesting findings about the new package solution which can be easily modified and applied to many standard wooden houses.

RESULTS AS QUALITIES OF THE BUILDING ENVELOPE AND BENEFITS OF THE PACKAGE SOLUTION

The wrap-up solution (Figure 2) is described in the following chapter describing how the renovation will proceed accompanied by selected important detailed solution (Silins and Vasilevskis, 2011) and only considers the qualities of the building envelope of standard wooden house 18D (Figure 1). The indoor air climate must be provided with the installation of a mechanical ventilation system with heat recovery. This is however not part of the paper. The current state of the house is compared to the expected situation after the wrap-up solution is applied as listed in Table 1. Moreover, the benefits from the package solution are concluded.

Table 1. Parameters Related to the Qualities of the Building Envelope for Original and Wrap-up Solutions

Parameter	Symbol and Unit	Original	Wrap-up
Insulation thickness in walls	[mm]; [in]	100; 3.94	100+300; 3.94+11.81
U_{wall}	[W/(m ² .K)]	0.497 ⁽¹⁾	0.126 ⁽²⁾
RSI_{wall}/R_{wall}	[m ² .K/W]; [h.ft ² .F/Btu]	2.0; 11.4	7.9; 45.1
Insulation thickness in floor	[mm]; [in]	100; 3.94	100+350; 3.94+13.78
U_{floor}	[mm]; [W/(m ² .K)]	0.439 ⁽¹⁾	0.122 ⁽²⁾
RSI_{floor}/R_{floor}	[m ² .K/W]; [h.ft ² .F/Btu]	2.3; 12.9	8.2; 46.5
Insulation thickness in roof	[mm]; [in]	100; 3.94	100+350; 3.94+13.78
U_{roof}	[mm]; [W/(m ² .K)]	0.434 ⁽¹⁾	0.122 ⁽²⁾
RSI_{roof}/R_{roof}	[m ² .K/W]; [h.ft ² .F/Btu]	2.3; 13.1	8.2; 46.5
$U_{glazing} \& U_{window}$	[W/(m ² .K)]	2.0; 3.0	1.1; 1.5
$RSI_{glazing}; R_{glazing}$	[m ² .K/W]; [h.ft ² .F/Btu]	0.5; 2.8	0.9; 5.2
$RSI_{window}; R_{window}$	[m ² .K/W]; [h.ft ² .F/Btu]	0.3; 1.9	0.7; 3.8
Leakage air change	$n_{50}; n$ [h ⁻¹] ⁽³⁾	18.5; 0.78	< 2.0; < 0.10
Interior temperature	T_i ; [°C]	23.0-25.0	20.0-23.0
Interior temperature	[°F]	73-77	68-73
Interior relative humidity	RH; [%]	25.8-29.2	30.0-35.0

⁽¹⁾ Lambda of insulation in 1962 was 0.049 W/(m.K) (or 0.028 Btu/(hr.ft.F) respectively) ⁽²⁾ compared to 0.033 W/(m.K) today (or 0.019 Btu/(hr.ft.F) respectively). ⁽³⁾ $A_{gross} = 63 \text{ m}^2$ (678 ft²). $V = 157 \text{ m}^3$ (5 545 ft³).

Principal of wrap-up solution

The new façade will be mounted and the old fillets covering the joints of the cladding has been moved. For houses with earlier renovated façades, e.g. if extra insulation is applied without new vapour barrier as in 1980s (GTO, 1985) or later, the extra layer is removed and the back boards are applied again and used as an underlay for the vapour barrier. The overhang will be sawed off at the line of the surface of the existing cladding, and the façade will be cleaned and smoothed to avoid breaking the vapour barrier. The studs in double windows are removed and all inlets are closed and properly sealed. New vapour barrier is applied to the walls with a glued and fixed overlay to the roof paper and to the foundation. The old windows and doors are removed and two diagonal cuts are made in the vapour barrier covering the windows and doors in order to be able to bend it inwards and fix it to the sides of the window hole before mounting the boxes of semi rigid boards to which the new windows and door are mounted. The mounting of the semi-rigid insulation to the roof and walls is done with a single screw in each insulation sheet. A wind membrane is mounted and the battens are fixed with screws into the existing construction. The battens on the roof are fixed to the battens on the wall and are hence keeping the battens on the walls in place. New roof boards and cladding boards are fixed to the battens. The overhang is recreated in the same shape as before, and added as a part of the new façade and the house will be painted in the same way as today. In the crawl space, the sound boarding is removed and the existing insulation is replaced with the new formwork mounted under the beams and a new vapour barrier is fixed to the interior side of the foundation. The insulation is mounted the same way as described at the walls and treated battens are mounted as formwork under a wind barrier. The principal of energy renovation is shown in Figure 2 following with the system for cladding and insulation in Figure 3, details for foundation/walls in Figure 4 and wall/roof in Figure 5, and vertical cross-section of window in Figure 6.

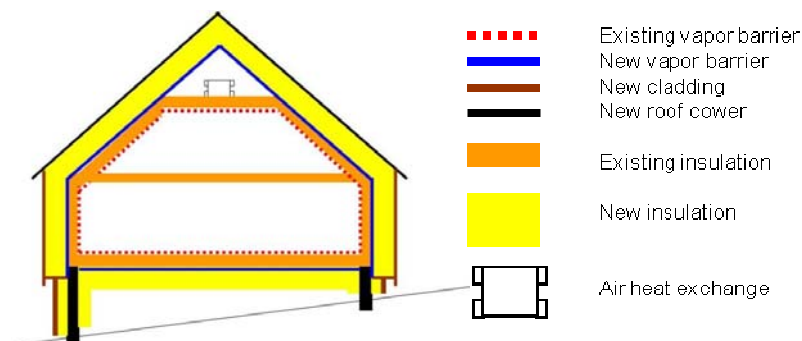

Figure 2 Principal of energy renovation for standard wooden houses.

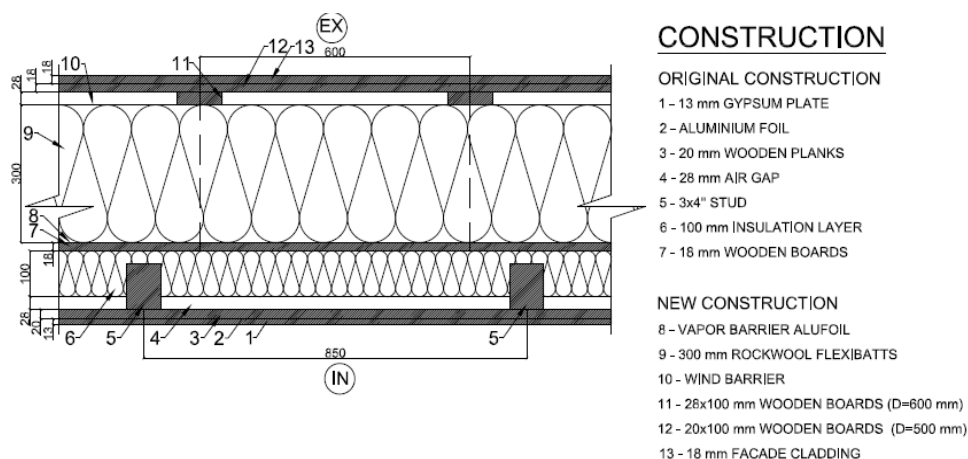

Figure 3 Vertical cross-section of external wall including material list.

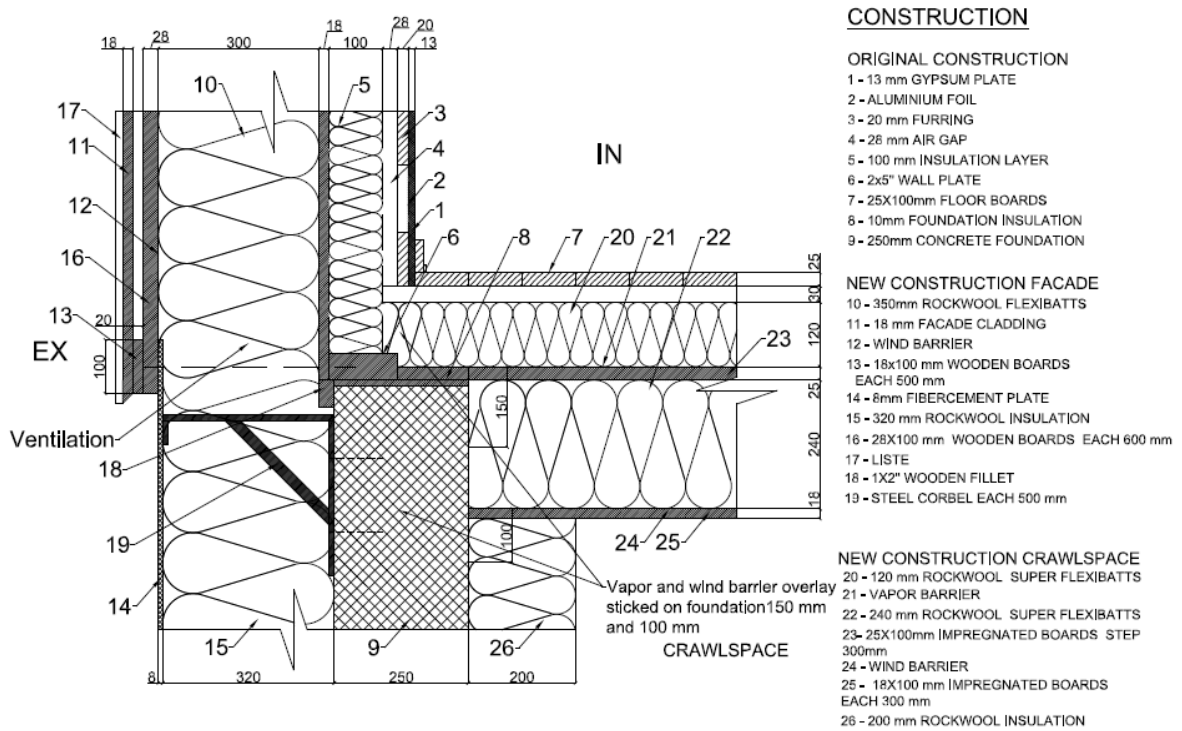

Figure 4 Schematic selected details for foundation/wall including material list.

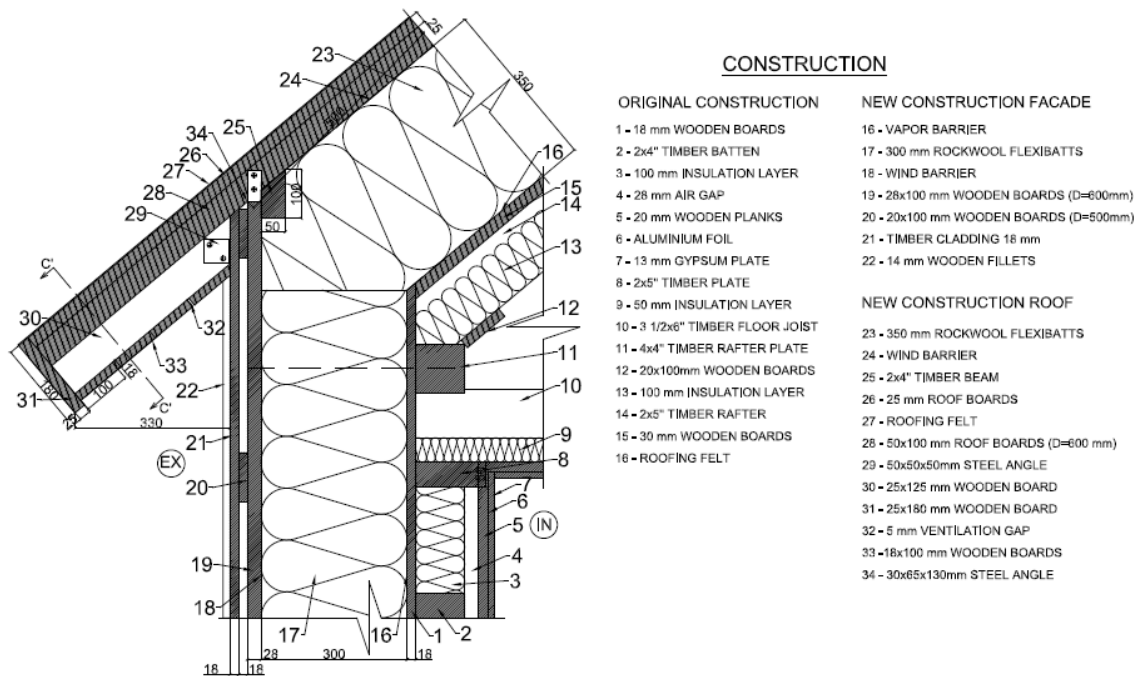

Figure 5 Schematic selected details for wall/roof including material list.

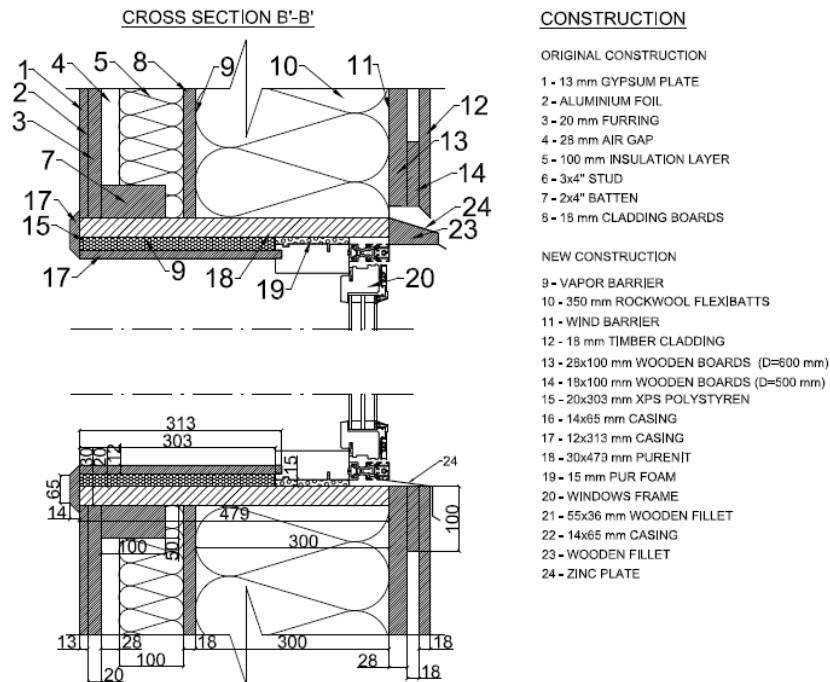

Figure 6 Schematic selected details of vertical cross-section of window detail including material list.

Vapour and air tightness. In the current state, the standard wooden houses have an interior vapour barrier from aluminium-covered paper which is considered to be un-tight and only partly functioning. The location of the new vapour barrier is following the thumb rule of maximum one-third of the cavity insulation is placed to its warm side. The technical parameters of the vapour barrier must ensure high vapour tightness ($S_d > 200$ m or 7,870 in respectively) with very effective sealing system (with overlaying and taping over). The membrane must be robust for more secure installation. The mounting of the vapour barrier directly on the existing cladding and formwork gives a more secure way of avoiding leakage. By using a membrane system with special designed solutions for outgoing and ingoing corners, furring of the window holes, perforating tubing and electrical pipes, the risk of faulty and un-tight installation is reduced. After finishing of the airtight barrier, the blower-door test will be performed (EN 13829, 2011) before mounting of the insulation.

Thermal quality. The standard wooden house is built using single-stud frame constructions of external walls. Floor and roof are completed with 100 mm/3.9 in of mineral wool insulation. The wooden frames have roughly 3 times the heat flow of the insulation materials and in many place this result in thermal bridges. The wrap-up solution significantly improves the thermal quality of the structures by approximately 75-80%. And the high level of insulation with very few thermal bridges is accompanied with highly technically solved details. The insulation material are semi-rigid boards (bats) from mineral wool with the thermal conductivity of $\lambda = 0.033$ W/K, the water-diffusion openness $d = 0.14$ kg/m.s.GPa and density of 75 kg/m³. The semi-rigid boards are self-supporting and the boards, which have soft edges, are laid vertically and pressed slightly together to provide a better solution for airtightness compare to the other materials like PIR, PUR etc.

Load-carrying capacity. The investigation shows that the current load-carrying structure from the studs will be able to hold additional weight of a new façade. The load calculations include self-weight, imposed and snow load (Silins and Vasilevskis, 2011). The additional façade is fixed using three systems: 1. Simple steel corbels fixed at distance of 500 mm/19.7 in to the concrete foundation to carry a part of the weight of the new facade, 2. Five screws per 1 m²/10 ft² of façade (7 screws for roof) mounted in inclined downward orientation to avoid condensing water to run into the construction, 3. The battens of the walls are fixed to the battens of the roof, and this way the battens on the roof carry

a part of the façade. The studs between double windows in west façade are removed, and a box beam is constructed by connecting two members in the framework of the wall above the window by replacing the gypsum board with a piece of 12 mm/0.5 in plywood.

Hydrothermal and wind protection. Air and wind tightness of external wall was ensured by ventilated external cladding with a windshield of tarred paper in the original house. In the wrap-up solution, all the external walls will be equipped with wind barrier laid on the semi-rigid boards and fixed with staples and adhesive tapes. The façade is completed with a cladding of vertical wooden boards leaving a ventilated gap between the wind barrier and the cladding. The roof is fixed similarly and completed with roof paper. The floor towards basement is solved using a special approach where this construction is treated as a façade and therefore has the same requirements. Old insulation in the floor is replaced with new one and new vapour is applied; boards are fixed perpendicular on the floor beams; and extra insulation is applied followed with wind barrier and another boards. Along the perimeter, extra insulation is applied on both sides of the vertical concrete foundation walls.

Ventilated crawl space. Formerly, the crawl space under the house was a limited ventilated cold basement partly used for storage. The crawl space will still be ventilated in the future with the proper sloping secured along with proper ventilation so no moisture from the ground or other elements will have the possibility to accumulate and condensate on the new floor construction. The total area of the basement is 84 m² for both houses with proposed new nine circular openings in the foundation with a diameter of 350 mm/13.8 in, i.e. total minimum area equal to 1/150 of the net basement area.

Fire safety. The two adjacent houses have a partition wall of bricks in common for fire safety purpose. The Greenlandic Building Regulation (Grønlands Hjemmestyre. 2006) demands a non-flammable solution. The wrap-up solution handles the fire protection using the semi-rigid mineral wool boards which are non-flammable (category A) which leaves out PIR, PUR, EXP, ESP and other similar burnable materials which are commonly used in several other countries.

Benefits of the package solution

Indoor climate and building systems. In the current state, the interior temperature in the buildings varies between 23.0-25.0°C/73-77°F on average and the interior relative humidity is between 25.8-29.2%. The houses are often overheated by sun in the summer, and in winter the building struggles with fluctuation of the interior temperatures as the building envelope is influenced by cold ambient temperatures around -20.0°C/-4°F. After the application of wrap-up solution and ventilation system, the indoor climate in the house is expected to improve to interior temperature between 20.0-23.0°C/68-73°F on average and interior relative humidity between 30.0-35.0% (Vladykova and Bjarløv, 2012). The building will have better temperature stability, i.e. the response to the outdoor climate will be more stabilized, and thus, the building will provide better indoor climate for its inhabitants.

Energy savings. After failed attempts of renovation in Greenland in past decades aiming to decrease energy consumption, this wrap-up method is expected to be broadly accepted since it can be applied to the majority of the residential building stock. The existing buildings are consuming up to 381 kWh/(m².a) just for space heating (120,800 Btu/ft².a respectively). By using wrap-up solution the energy consumed in the house is expected to decrease to 40-60 kWh/(m².a) for heating and partly for hot water consumption (or 12,680-19,000 Btu/ft².a respectively). The monitoring system will secure the measurements of energy, air flows and indoor climate (Bjarløv and Vladykova, 2011).

Greenhouse gas emissions (GHG). The supplied energy to the 11,452 of existing buildings comes from the oil and equals to approximately 52,600 tonnes of CHG emissions calculated for the average consumption of 317 kWh/(m².a)/100,500 Btu/ft².a with an average floor area of 65.5 m²/705 ft². If the emissions for the transport by ship and production of insulation are deducted, the total annual saving in greenhouse gas emissions equals to 42,700 tonnes. The greenhouse gas emissions for using oil for oil-fired boilers is 0.245 kg per kWh (GEMIS, 2010), and if all 11,452 houses are renovated using the wrap-up solution the total greenhouse gas emission savings equals to 87% per year, i.e. 703 tonnes of GHG emissions per m² per year (Bjarløv and Vladykova, 2011).

Architectural expression and heritage. Along with the beautiful nature, these spectacular wooden houses are the heritage of Greenland and this method aims at keeping the look of the houses, and, thus, keeping the same architectural expression. The wrap-up method provides a better technical solution as all materials for the building envelope are applied from the outside resulting in very little interferences with the interior.

Span across the Arctic regions. The building system using single-stud system has often been used for building houses in the cold climate regions. The building method using a package solution is ideal for settlements located in the far north and it has the potential to span across the regions of Scandinavia and Canada. The advantage lies in transport, good technical solution of details and the reduction of energy consumption in buildings. Using network and sharing the knowledge about this method can help to reduce energy coming from the non-renewable resources and be consumed in the buildings across the Arctic.

Further work. The windows considered for the project are either with three-glazing panes, or two-glazing layers and additional single layer located on the outer side. Nowadays every room in the building is naturally ventilated through a vent (150 x 150 mm) with a manually operated grill. The unit with rotary heat exchanger is considered for the option of heat and moisture recovery, and better performance in regions with extremely cold climate. The heating system is a combi oil-fired boiler with radiators providing space heating and hot water. Additional renewable energy sources will be considered such as solar thermal system or photovoltaic panels.

DISCUSSION AND CONCLUSION

The proposed wrap-up solution focuses on the highly super-energy solution for renovation of more than half of the residential stock in Greenland. The interesting wrap-up and package solution can be easily modified, transported and applied anywhere in the Arctic regions. Application of this solution as a retrofitting method leads to approximately 86% savings in energy and greenhouse gas emissions. Along with the wrap-up solution, a comprehensive ventilation system with heat recovery must be installed to provide a good indoor climate as part of the further work.

REFERENCES

- Bjarløv S.P. and Vladykova P. 2011. The potential and need for energy saving in standard family detached and semi-detached wooden houses in Greenland. *Building and Environment*, 46, 1525-1536.
- CCHRC. 2007. REMOTE: Residential Exterior Membrane Outside - insulation Technique, Research Snapshot 07-03. Cold Climate Housing Research Center. Available at: <http://www.cchrc.org/Reports>
- Craven and Garber-Slaght. 2010. Safe and Effective Exterior Insulation Retrofits: Phase 1. Cold Climate Housing Research Center. Available at: <http://www.cchrc.org/Reports>
- Craven and Garber-Slaght. 2012. Safe and Effective Exterior Insulation Retrofits: Phase 2. Cold Climate Housing Research Center. Available at: <http://www.cchrc.org/Reports>
- EN 13829. 2011. Thermal performance of buildings. Determination of air permeability of buildings. Fan pressurization method. European Standard. CEN.
- GEMIS. 2010. Global Emission Model for Integrated Systems [homepage on the Internet]. Oeko Institute [cited Oct 27, 2010]. Available at: <http://www.oeko.de/service/gemis/en/index.htm>
- Grønlands Hjemmestyre. 2006. Bygningsreglement 2006. Direktoratet for Boliger og Infrastruktur. Available at: <http://www.nanoq.gl> (in Danish).
- Grønlands Tekniske Organization (GTO). 1985. BSU Typehuse. Modernisering og udvidelse (in Danish).
- Silins U. and Vasilevskis S. 2011. Internship report. Renovation project: The type house 18D. Student report. Technical University of Denmark.
- Ueno K. 2010. Residential Exterior Wall Superinsulation Retrofit Details and Analysis. Research report 1012. Building Science Press.
- Vladykova P. and Bjarløv S.P. 2012. Prospective future introduction of reduction of energy use in buildings in the Arctic regions – How might it affect the indoor climate? 10th International Conference on Healthy Building 2012. Brisbane, Australia. In publishing process.