

Technical University of Denmark



Impact Study of Electric Vehicle (EV) Integration on Low Voltage (LV) Grids

Wu, Qiuwei; Cha, Seung-Tae; Nielsen, Arne Hejde; Østergaard, Jacob; Ding, Yi

Published in:
Proceedings 2012 CIGRE SESSION

Publication date:
2012

Document Version
Early version, also known as pre-print

[Link back to DTU Orbit](#)

Citation (APA):
Wu, Q., Cha, S-T., Nielsen, A. H., Østergaard, J., & Ding, Y. (2012). Impact Study of Electric Vehicle (EV) Integration on Low Voltage (LV) Grids. In Proceedings 2012 CIGRE SESSION (pp. C6-105)

DTU Library

Technical Information Center of Denmark

General rights

Copyright and moral rights for the publications made accessible in the public portal are retained by the authors and/or other copyright owners and it is a condition of accessing publications that users recognise and abide by the legal requirements associated with these rights.

- Users may download and print one copy of any publication from the public portal for the purpose of private study or research.
- You may not further distribute the material or use it for any profit-making activity or commercial gain
- You may freely distribute the URL identifying the publication in the public portal

If you believe that this document breaches copyright please contact us providing details, and we will remove access to the work immediately and investigate your claim.



21, rue d'Artois, F-75008 PARIS
<http://www.cigre.org>

Paper number
C6-105

CIGRE 2012

Impact Study of Electric Vehicle (EV) Integration on Low Voltage (LV) Grids

**Qiuwei Wu, Seung Tae Cha, Arne Hejde Nielsen, Jacob Østergaard and Yi Ding
Centre for Electric Technology (CET), Technical University of Denmark
Denmark**

SUMMARY

Large scale deployment of electric vehicles (EVs) has become a very interesting option because it can both reduce the greenhouse gas (GHG) emission from the transport sector and facilitate the integration of more renewable energy resources (RES) by providing the flexibility of EV charging demands. Although the EV grid integration is promising, the impact of the EV grid integration has to be investigated in order to identify the bottlenecks of power systems for the EV grid integration and assess different charging scenarios.

This paper is focused on the impact of EV grid integration on low voltage (LV) grids. The work consists of modeling a typical LV grid, EV charging schedule management, and impact study of different charging scenarios on LV grid.

The modelling work of the LV grid is done using the data from the Bornholm power system. The topology data of the LV grid are used to develop the single line diagram (SLD) of the LV grid. The demand profiles of end-users are determined by the end-user yearly consumption and averaged demand profiles of different customer types in Denmark.

Five charging scenarios have been tested using the developed LV grid. The first two charging scenarios are dumb charging all day and dumb charging night. The third charging is timed charging. The fourth and fifth charging scenarios are fleet all day and fleet night charging scenarios.

Beside the five charging scenarios, two charging power levels will be tested as well in combination with the charging scenarios. The two charging power levels are 1 phase 16 A and 3 phase 16 A.

The loading of the power components and voltage profile are analyzed to quantify the impact of the charging scenarios and charging power levels on LV grids.

KEYWORDS

Electric Vehicle Integration, Impact Study, Low Voltage Grid, Charging Scenarios

1 Introduction

The deployment of a large number of electric vehicles (EV) has become a very interesting option. Replacing conventional internal combustion engine (ICE) vehicles with EVs will reduce the greenhouse gas (GHG) emission from the transport sector. In the mean time, the flexibility of EV charging demands can be used to balance the intermittency of renewable energy resources (RES). Although the EV grid integration is beneficial to the environment and can help integrate more RES into power systems, the impact of EV grid integration has to be investigated in order to identify the bottlenecks of power systems for the EV grid integration and test different charging scenarios.

Denmark offers a unique opportunity for renewable energy utilization and EV deployment. At present, the wind power penetration level in Denmark is around 20%, and the Danish government has set a target of 50% penetration of wind power by 2025 [1]. The average driving distance in Denmark is approximately 40 km per day [2], which is sufficiently low to allow a fully charged 25 kWh battery to provide enough energy to meet daily driving requirements in most cases. If additional energy is required, the EV batteries can be recharged during the day where there is an appropriate charging infrastructure in place.

Congestion from EVs can be observed at the medium voltage (MV) level, as a number of studies demonstrate [3]-[4]. Many studies have been conducted analyzing congestion issues on the MV network, however they also note that the problems likely originate on the LV network, and as such, analysis of this network should be conducted as the primary stage of congestion studies [3], [5], [6].

The degree of grid congestion is dependent on a number of factors including local grid rating and topology, penetration and distribution of EVs, and charging management procedures. Coordinated charging appears to be an effective method of increasing the penetration of EVs without violating grid constraints. There is some incongruity on the optimal manner in which to coordinate charging, with a number of different objectives proposed, including maximization of EV penetration [3], minimization of losses [4], and minimization of customer charging costs [7]-[8]. The study conducted in [7] shows that substantial computational power is required to handle grid constraints in an iterative optimization for EV charging management.

Another method of grid congestion prevention is the inclusion of devices in chargers that detect voltage and halt charging when the voltage drops beyond a given threshold. Alternatively the power factor could be adjusted to rectify the voltage drop. These methods are mentioned in a number of papers [9]-[11].

In order to handle the congestion from EV charging and identify the bottlenecks in LV grid, it is very important to use realistic driving data to determine the EV charging demands. In this paper, the vehicle driving data in Denmark has been used to determine the EV charging demands which are the inputs for the EV impact study.

The work in this paper consists of modeling a typical LV grid, smart charging schedule management based spot prices, and impact study of different charging scenarios on LV grid.

The rest of the paper is arranged as follows. In Section II, the details of the five charging scenarios are described. The EV grid impact study is presented in Section III. The modelling work of a typical LV grid of the Bornholm power system is explained in Section IV. Case study results are presented in Section V to investigate the impact of different EV charging scenarios on LV grids. In the end, conclusions are drawn according to the case study results.

2 EV Charging Scenarios

Five charging scenarios have been considered for the EV charging management. The five charging scenarios are listed below.

- Dumb charging all day
- Dumb charging home
- Timed charging
- Fleet charging all day
- Fleet charging home

In the "dumb charging all day" scenario, each EV is charged each time when it is connected up to full state of charge (SOC).

In the "dumb charge home" scenario, each EV is charged up to full SOC when it returns home after the last driving tour of the day. The driving data set contains a purpose field describing the purpose of the driving tour, which is used in order to determine when the EV is driving home. Data when the EV is not driving home as the last tour of the day are not included in the analysis.

The "timed charging" scenario is configured so the EV starts charging at a certain time of the day (= 10pm) if it is connected. If not connected it will start charging when it returns back home after 10pm and will charge up to full COSOC (contractual SOC), which could be equal to 85% SOC.

The "fleet charging all day" scenario is designed so that the EV will be optimally charged up to full COSOC (e.g. equal to 85% SOC) each time the EV is connected also during the day. when the cost of electricity is high, this strategy will tend to put the charging in the middle of the day when the price of electricity slightly is lower compared to the two peaks hours (one in the morning one in the afternoon).

The "fleet charging night" scenario is the optimal charging strategy, only charging when the expected spot price is at its lowest. The charging is placed during the time when the expected spot price is low – which in a Danish context typically is during nighttime.

The fleet charging scenarios can be depicted as the optimization problem below.

Objective function

$$\min \sum_{t=1}^T \sum_{n=1}^N C_t E_{n,t} \quad (1)$$

Constraints

$$0 \leq E_{n,t} u_{n,t} \leq E_{max} \quad \forall t \quad (2)$$

$$SOC_{min} \leq SOC_{init} + \sum_{t=1}^{\tau_n} E_{n,t} u_{n,t} - \sum_{t=1}^{\tau_n + \tau_{n,d}} E_{n,d,t} v_{n,t} \leq SOC_{max} \quad \forall t, n \quad (3)$$

$$u_{n,t} + v_{n,t} \leq 1 \quad (4)$$

where C_t is the day-ahead electricity price at time t [DKK/kWh], $E_{n,t}$ is the driving Energy requirement for EV n during period t [kWh], E_{max} is the maximum charging energy during period t [kWh], SOC_{min} is the minimum battery state of charge (SOC), SOC_{max} is the maximum battery SOC, SOC_{init} is the initial battery SOC, τ_n is the set of time at which vehicle becomes unavailable for charging, $\tau_{n,d}$ is the set of durations for which vehicle is unavailable for charging, $v_{t,n}$ is the binary parameter signifying EVs driving status - 1=driving and 0=available to charge, i is the bus index, n is the EV index, $E_{n,t}$ is the charging energy for EV

n during period t [kWh], $u_{t,n}$ is the binary control variable signifying EVs charging status - 1=charging and 0=not charging.

For the fleet all day charging scenario, the SOC will be the COSOC before each trip. For the fleet night charging scenario, the charging activities only take place when the cars are parked home.

3 EV Grid Impact Study

The intention of the grid impact study of EV integration is to investigate and quantify the impact of different EV charging scenarios on the grid operation from the power component loading and voltage profile perspectives.

The general idea of the grid impact study of EV integration is to carry out daily time series power flow studies using grid model, existing demands and EV charging demands based on the EV charging schedules. The process of the EV grid impact study is illustrated in Figure 1.

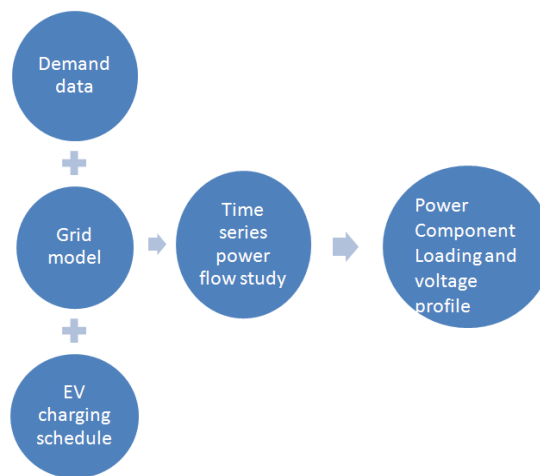

Figure 1 Flowchart of EV grid impact study

4 Modelling of A Low Voltage (LV) Grid of the Bornholm Power System

The modeling work of the LV grid is comprised of both demand modeling and the topology of the grid.

It is a challenge to model demands because there are no real time measurements of end-user demands. The available demand data are the yearly consumption data of end-users. Therefore, it is very important to find a proper way to model the demand profiles of end users using the yearly consumption.

In Denmark, the yearly averaged demand profile of each customer category is available. Although the demand profile levels out the difference of different customers within the same category, it is a good representation of the demand profile and can be used to determine the end user hourly demands with the yearly electricity consumption.

A typical 400 V grid of the Bornholm power system has been modeled in PowerFactory and the single line diagram (SLD) of the grid is shown in Figure 2.

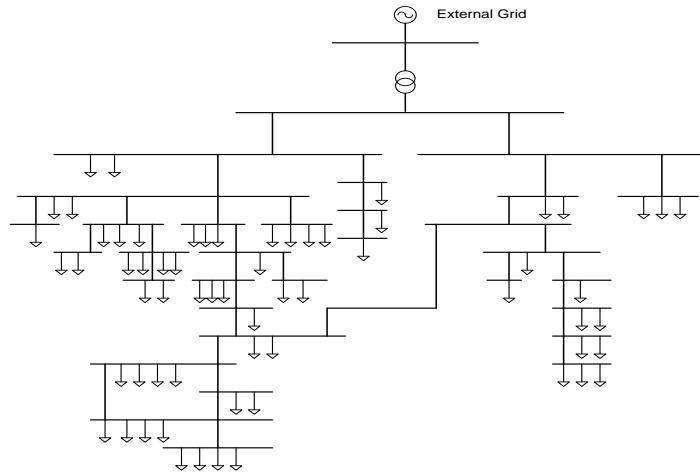

Figure 2 Bornholm 400 V Grid Model in PowerFactory

In the typical 400 V grid, there are totally 64 customers and 6 customer types. The details of the customer number and types are listed in Table 1.

Table 1 Customer Type and Number of the typical Bornholm 400 V grid

Customer Type	Customer Number
111 Apartment without electric heating	36
112 Apartment with electric heating	14
121 Family house without electric heating	7
130 Weekend cottage	5
441 Electricity, gas, water and heat supply	1
446 Postal services and telecommunication	1

5 Case Studies

The 400 V grid described in Section 4 has been used to carry out the EV grid impact study on 400 V grids.

The study results with single phase or three phase charging, three penetration levels and five charging scenarios are presented in this section. The two charging power levels are 1 phase 16 A and 3 phase 16 A. The five charging scenarios are specified in Section 2. The three EV penetration levels are 10%, 15% and 20%, respectively.

The results show that the transformers are the bottlenecks of the 400 V grid. The loading of transformer(s) is much higher than the cables. The results of 10% EV penetration and 3 phase charging are used to illustrate the statement which are shown in Figure 3 and Figure 4. It is shown that the loading of transformer(s) is much higher than the one of cables.

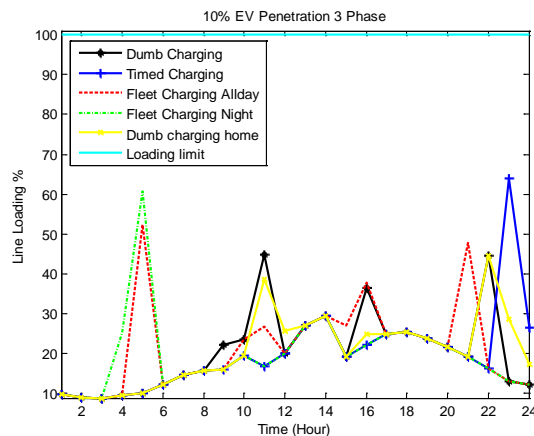

Figure 3 Line Loading 400 V – 10% EV penetration and 3 phase charging

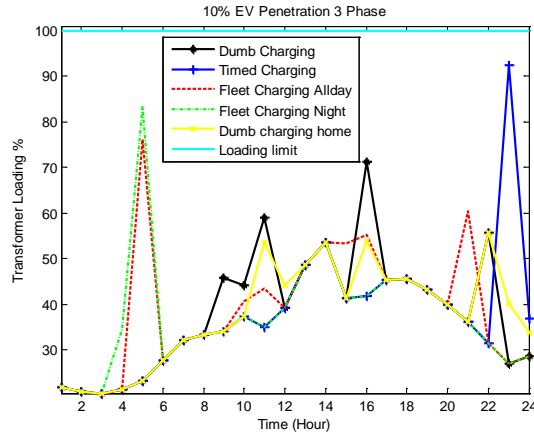

Figure 4 Transformer loading 400 V – 10% EV penetration and 3 phase charging

It is shown in Figure 5 that there will be transformer overloading for fleet night charging and timed charging scenarios when the EV penetration is 15% with three phase charging option. The results show that the economically efficient EV charging scenario might cause problems on the LV grid and it is very important to design market driven or technical measures to handle the LV grid congestion issues due to the EV charging demands.

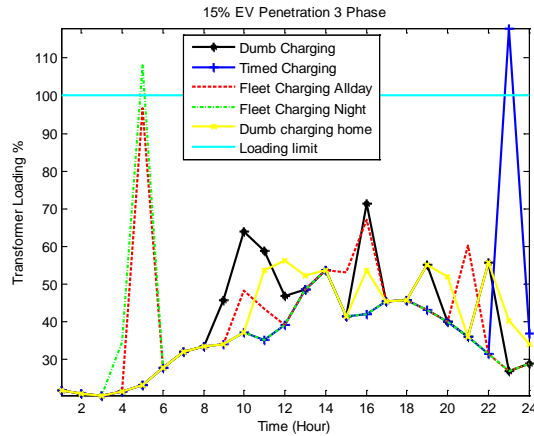

Figure 5 Transformer loading 400 V – 15% EV penetration and 3 phase charging

Another interesting finding is the “dumcharing” EV demands are quite distributed and the peak load with economically efficient charging scenario may be higher than the one with “dumbcharging”. It is due to the distribution of the time when EVs reach home which is shown in Figure 6.

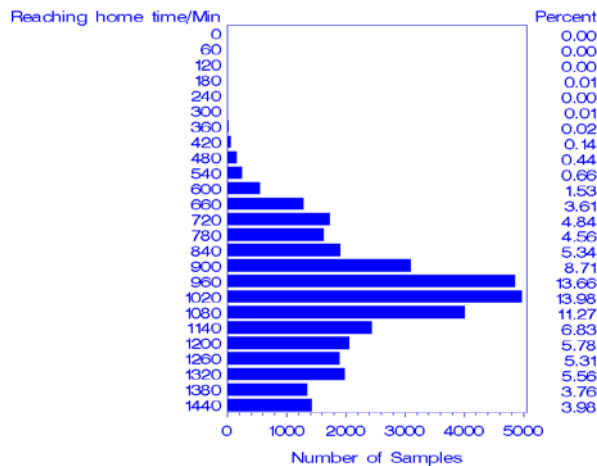

Figure 6 Distribution of the time when EVs reach home

7 Conclusions

The EV grid impact study has been done using a typical LV grid of the Bornholm power system to assess the effects of different charging scenarios on the operation of LV grids. Two charging power levels, three EV penetration levels and five EV charging scenarios have been considered in the case studies.

Based on the case study results, it can be concluded that the transformers are the bottlenecks of LV grids to handle the EV charging demands. The dumbcharging EV demands are quite distributed due to the quite flat distribution of EV reaching home time. In the case of 3 phase 16 A charging, it is very important to design an efficient scheme to alleviate the congestion caused by EV charging demands, e.g. efficient DSO market to stimulate the EV charging demand shifting, direct control, etc.

BIBLIOGRAPHY

- [1] Z. Xu, M. Gordon, M. Lind and J. Østergaard “Towards a Danish Power System with 50% Wind – Smart Grids Activities in Denmark” (IEEE PES General Meeting 2009 July 26-30 2009 pages 1-8)
- [2] Q. Wu, A. H. Nielsen, J. Østergaard, S.T. Cha, F. Marra, Y. Chen and C. Traeholt “Driving Pattern Analysis for Electric Vehicle (EV) Grid Integration Study” (IEEE PES Conference on Innovative Smart Grid Technologies Europe 2010 October 11-13 2010 pages 1-6)
- [3] J. A. P. Lopes, F. J. Soares and P. M. R. Almedia “Identifying Management Procedures to Deal with Connection of Electric Vehicles in the Grid” (IEEE Buchsrest PowerTech 2009 June 28 – July 2 2009 pages 1-8)
- [4] K. Clement, E. Haesen and J. Driesen “Coordinated Charging of Multiple Plug In Hybrid Electric Vehicles in Residential Distribution Grids” (IEEE PES Power Systems Conference and Exposition 2009 March 15-19 2009 pages 1-7)
- [5] A. Maitra, K. S. Kook, J. Taylor and A. Giumento “Grid Impacts of Plug-In Electric Vehicles on Hydro Quebec's Distribution System” (IEEE PES Transmission and Distribution Conference and Exposition 2010 April 19-22 2010 pages 1-7)
- [6] J. Taylor, M. Maitra, D. Alexander and M. Duvall “Evaluation of the Impact of Plug-In Electric Vehicle Loading on Distribution System Operations” (IEEE Power&Energy Society General Meeting 2009 July 26-30 2009 pages 1-6)
- [7] O. Sundstorm and C. Binding “Planning Electric-Drive Vehicle Charging under Constrained Grid Conditions” (International Conference on Power System Technology 2010 October 24-28 2010 pages 1-6)
- [8] N. Rotering and M. Ilic “Optimal Charge Control of Plug-In Hybrid Electric Vehicles in Deregulated Electricity Markets” (IEEE Transactions on Power Systems number 3 August 2011 pages 1021-1029)
- [9] S. Babaeim, D. Steen, L. A. Tuan, O. Carlson and L. Bertling “Effects of Plug-in Electric Vehicles on distribution systems: A real case of Gothenburg” (IEEE PES Conference on Innovative Smart Grid Technologies Europe 2010 October 11-13 2010 pages 1-8)
- [10] K. J. Dyke, N. Schofield and M. Barnes “The Impact of Transport Electrification on Electrical Networks” (IEEE Transactions on Industrial Electronics number 12 pages 3917 – 3926)
- [11] J. A. P. Lopes, F. J. Soares and P. M. R. Almedia “Integration of Electric Vehicles in the Electric Power System” (Proceedings of the IEEE number 1 January 2011 pages 168-183)