

Technical University of Denmark



## Protection algorithm for a wind turbine generator based on positive- and negative-sequence fault components

Zheng, Tai-Ying; Cha, Seung-Tae; Crossley, Peter A.; Kang, Yong-Cheol

*Published in:*  
Proceedings of APAP

*Publication date:*  
2011

*Document Version*  
Early version, also known as pre-print

[Link back to DTU Orbit](#)

*Citation (APA):*  
Zheng, T-Y., Cha, S-T., Crossley, P. A., & Kang, Y-C. (2011). Protection algorithm for a wind turbine generator based on positive- and negative-sequence fault components. In Proceedings of APAP (pp. 1115-1120). IEEE.

## DTU Library

Technical Information Center of Denmark

---

### General rights

Copyright and moral rights for the publications made accessible in the public portal are retained by the authors and/or other copyright owners and it is a condition of accessing publications that users recognise and abide by the legal requirements associated with these rights.

- Users may download and print one copy of any publication from the public portal for the purpose of private study or research.
- You may not further distribute the material or use it for any profit-making activity or commercial gain
- You may freely distribute the URL identifying the publication in the public portal

If you believe that this document breaches copyright please contact us providing details, and we will remove access to the work immediately and investigate your claim.

# Protection algorithm for a wind turbine generator based on positive- and negative-sequence fault components

Tai-Ying Zheng<sup>1</sup>, Seung-Tae Cha<sup>2</sup>, Peter A. Crossley<sup>3</sup>, and Yong-Cheol Kang<sup>1,4\*</sup>

<sup>1</sup>Department of Electrical Engineering and Wind energy Grid-Adaptive Technology Research Center (WeGAT), Chonbuk National University, Korea;

<sup>2</sup>Department of Electrical Engineering, Technical University of Denmark, Lyngby, DK-2800, Denmark;

<sup>3</sup>School of Electrical and Electronic Engineering, University of Manchester, Manchester, UK;

<sup>4</sup>Smart Grid Research Center, Chonbuk National University, Korea

**Abstract:** A protection relay for a wind turbine generator (WTG) based on positive- and negative-sequence fault components is proposed in the paper. The relay uses the magnitude of the positive-sequence component in the fault current to detect a fault on a parallel WTG, connected to the same power collection feeder, or a fault on an adjacent feeder; but for these faults, the relay remains stable and inoperative. A fault on the power collection feeder or a fault on the collection bus, both of which require an instantaneous tripping response, are distinguished from an inter-tie fault or a grid fault, which require a delayed tripping, using the magnitude of the positive-sequence component in the fault current. The fault type is first evaluated using the relationships between the positive- and negative-sequence fault components depending on type of fault. Then the magnitude of the positive-sequence component in the fault current is used to decide on either instantaneous or delayed operation. The operating performance of the relay is then verified using various fault scenarios modelled using EMTP-RV. The scenarios involve changes in the position and type of fault, and the faulted phases. Results confirm that the relay can successfully distinguish between faults that require an instantaneous, delayed or non-operation response.

**Keywords:** Wind turbine generator protection, Outage section minimization, Instantaneous operation, Delayed operation, Non-operation, and Symmetrical components

## 1 Introduction

During the last decade, wind generation has become the most promising renewable energy technology. The EU, USA, China and India have integrated significant amounts of wind energy onto their electrical networks; this involved the construction of large wind farms, which resulted in economics of scale and the minimization of the adverse effects of wind fluctuations. Korea has started a project to construct a 2.5 GW off-shore wind farm near Jeollabuk-do on the western coast until 2019. As the penetration level increases, more reliable operation, control and protection systems are required.

New techniques for protecting a wind farm have been reported [1–3]. A source based protection relay using a shaped directional operating characteristic was proposed in [1, 2]. Whilst in [3], an adaptive distance relay that considered the conditions of the wind farm was described. These relays were installed at the point of common coupling, and if a fault occurred in the wind farm, the entire farm would be disconnected.

More conventional methods to protect an individual wind turbine generator (WTG) were proposed in [4, 5]. These methods use over/under voltage, over/under frequency, instantaneous phase/neutral over-current for generator phase/ground faults, and inverse time phase over-current for generator overload. They can successfully protect a WTG

when an internal fault occurs. However, they are not able to distinguish a collector feeder fault, a collector bus fault, an inter-tie fault and a grid fault. In addition, they cannot distinguish whether it is a connected feeder fault or an adjacent feeder fault. Thus, the outage section can be wider.

The above relays might be attractive for a small wind farm, but concern about the undesirable disconnection of a large wind farm is an issue for many operators. Ideally when a fault occurs, the size of the outage zone should be minimized; this increases the availability of the WTGs and reduces the impact on grid stability.

To achieve this objective, the protection relay for a WTG should operate instantaneously for a fault on the WTG, a connected feeder fault or a collector bus fault, and should operate after a delay for an inter-tie fault or a grid fault. In addition, the relay should remain stable for a fault on a parallel WTG connected to the same feeder or an adjacent feeder fault.

In order to minimize the outage zone in a wind farm, a protection relay for a wind turbine generator based on positive- and negative-sequence fault components is proposed in the paper. The relay uses an instantaneous directional algorithm based on the positive-sequence fault components to discriminate short-circuit faults internal to the generator from other faults. A fault on a parallel WTG, connected to the same power collection feeder, or a fault on an adjacent feeder, for which the relay should remain stable and inoperative, is detected using the magnitude of the positive-sequence fault component. A fault on the power collection feeder or a fault

\*Corresponding author (email: yckang@jbnu.ac.kr)

on the collection bus, both of which requires an instantaneous tripping response, are distinguished from an inter-tie fault or a grid fault, which require delayed trippings, using the magnitude of the positive-sequence fault component. The fault type is first evaluated using the relationships between the positive- and negative-sequence fault components, which depends on type of fault. Then the magnitude of the positive-sequence fault component is used to decide on either instantaneous or delayed operation. In order to verify the operating performance of the proposed relay, various fault scenarios, involving changes in the position and type of fault, and the phases involved in the fault, are modelled using EMTP-RV.

## 2 Wind farm model and WTG relay functions

### 2.1 Configuration of a wind farm

Fig. 1 shows a model of the 100 MW wind farm studied in this paper. Ten power collection feeders are connected to a collector bus, which is connected to the grid through a main transformer, substation bus and parallel inter-tie lines. Five induction generators, each rated at 2 MW, are connected to each feeder. All WTGs are fixed speed asynchronous squirrel cage induction generators (Type 1).

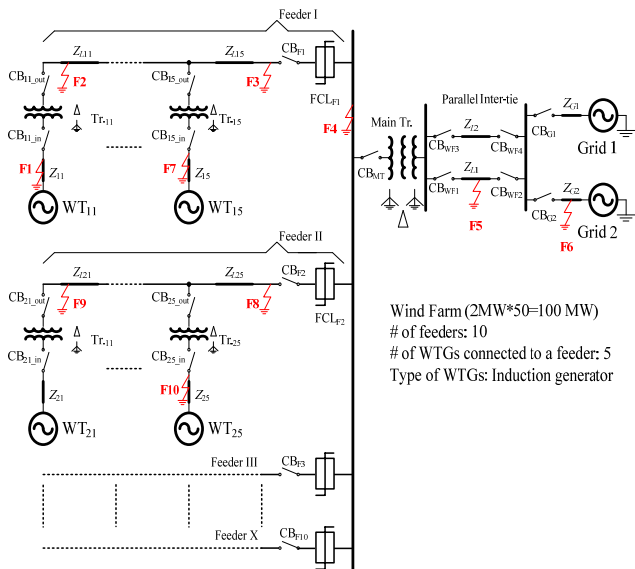

Figure 1 Wind farm model.

Table 1 Required relay functions for WT<sub>11</sub> to minimize an outage section.

Fault positions	Fault types	Required relay operation
F1–F4	SLG, LL, DLG, 3P	Instantaneous operation
F5–F6		Delayed operation
F7–F10		Non-operation

Fault current limiters (FCLs) are installed on each feeder at the feeder circuit breaker (CB), as seen in Fig. 1. FCLs are often used in a large wind farm to limit the fault current [6, 7].

The grounding impedance of the main transformer limits the fault current when a single line-to-ground (SLG) fault or a double line-to-ground (DLG) fault occurs, but it is not effective when a line-line (LL) fault or a three-phase (3P) fault occurs. The winding connection of the step-up transformers used with each WTG is grounded-wye-delta connected. This is because this connection provides isolation of the WTGs from the zero-sequence behavior of the collector feeder and a solid ground source for the low voltage side connected to WTGs [8]. A grounded-wye-grounded-wye transformer with a delta tertiary is used in the substation. The delta tertiary provides a ground source to both the medium voltage (MV) and high voltage (HV) level [9].

In some countries, a grounded-wye-delta transformer is used in the substation, identical to the connection typically used for conventional power plants. To provide effective grounding to the MV level, a very large and expensive grounding transformer is needed on the MV collector bus. It may be possible to design the MV system to have acceptable insulation coordination with a high-impedance ground using a smaller grounding transformer. However, this can be very challenging because of the unavailability of distribution-grade equipment that has sufficient insulation levels [9].

### 2.2 Required WTG relay functions

This subsection describes WTG (WT<sub>11</sub>, connected to Feeder I) protection relay’s functions to minimize an outage section when a fault occurs in a wind farm. Table 1 shows the functions that the WTG protection relay should have. F1–F10 in Fig. 1 show the fault positions.

F1 means an internal fault of a WT<sub>11</sub> whilst F2 and F3 mean connected feeder faults. F4 means a collector bus fault. In the cases F1–F4, the relay for WT<sub>11</sub> should operate instantaneously.

F5 represents an inter-tie fault. In this case, the WTG relay operation depends on the configuration of the inter-tie, single- or multiple-lines. The relay for WT<sub>11</sub> for a single-line should operate instantaneously. However, for multiple-lines, the relay should detect the fault and operate with a delay. In this paper, the configuration of the inter-tie assumes multiple-lines, which is necessary for a modern large wind farm. Thus, the WTG relay should operate with a delay. The delay time should be determined considering coordination time between the corresponding relays.

F6 indicates a grid fault, which locates far from a WTG. Modern grid codes in many countries require that the WTG or wind farm protection relay should have the low voltage ride-through (LVRT) capability in this case. Therefore, the WTG relay should be carefully designed to have LVRT capability considering grid codes of each country.

F7 means an internal fault on another WTG (WT<sub>15</sub>) connected to the same feeder. In this situation, the relay for WT<sub>15</sub> should operate instantaneously whilst the relay for WT<sub>11</sub> should not operate. F8–F10 mean adjacent feeder faults, including an internal fault of a WTG connected to an adjacent feeder, where the relay for WT<sub>11</sub> should not operate.

### 3 Positive- and negative sequence fault components based protection relay for a WTG

This paper uses the fault component of the current at the relaying point, which is defined as the fault-generated current, instead of the measured current at the relaying point. The fault component of the current at the relaying point is obtained by subtracting the load current from the measured current after the fault inception. It can be assumed that the magnitude of the load current during a very short period (e.g. two or three cycles) after the fault inception, remains the same as that prior to the fault. In this paper, the fault component of the current is calculated by subtracting the load current from the measured current at the relaying point during the fault as in [10].

Fig. 2 shows the flowchart of the proposed algorithm. The proposed algorithm is composed of the three stages. At stage 1, the magnitude of the positive-sequence fault component is used to distinguish F7–F10 faults from F1–F4, and F5/F6 faults. At stage 2, the fault direction is discriminated using an instantaneous directional algorithm based on the positive-sequence fault components, to distinguish F1 faults (forward faults) from F2–F4, and F5/F6 faults (backward faults). At the last stage, the type of fault i.e. SLG, LL, DLG or 3P, is evaluated using the relationships between the positive- and negative-sequence fault components, which depends on the type of fault. Then, the magnitude of the positive-sequence fault component is used to decide on either instantaneous operation (F2–F4 faults) or delayed operation (F5/F6 faults).

In this paper, at State 1 and the second part at Stage 3, the fault component is used rather than the phase current. The reason is as follows. Prior to the fault, the fault component is almost zero because the measured current at the relaying point equals the load current. When a fault occurs, however, the fault component significantly increases. Hence, the fault component is more effective in terms of detecting a fault and discriminating between the instantaneous operation and the delayed operation.

#### 3.1 Stage 1: Distinguishing F7–F10 Faults from F1–F4 and F5/F6 Faults

The magnitude of the positive-sequence fault component is used to distinguish faults at F7–F10 from those at F1–F4 and F5/F6. When a fault occurs at F7–F10, the relay for a WTG connected to the healthy feeder would “see” the fault through its step-up transformer and the FCL installed at the faulted feeder. The equivalent impedance to the fault is so large that the fault current flowing out are limited to a small value, which is almost similar to a normal load current. Hence, the magnitude of the positive-sequence fault component is not increased significantly, and is smaller than a threshold ( $K_1$ ) of a magnitude detector.  $K_1$  is decided by fault analysis of the studied system based on symmetrical components. It is reasonable to represent a Type 1 WTG as a voltage source in series with a direct axis sub-transient inductance, and calculate the maximum fault current using symmetrical components

during the first few cycles after a fault [9].

On the other hand, the relay for a WTG connected to the faulted feeder would “see” the fault only through its step-up transformer. That is why the magnitude of the positive-sequence fault component is increased significantly.

Thus, an internal fault of another WTG connected to the same feeder or an adjacent feeder fault, where the relay should not operate, can be discriminated successfully based on the magnitude of the positive-sequence fault component.

#### 3.2 Stage 2: Distinguishing F1 Faults from F2–F4 and F5/F6 Faults

The proposed protection algorithm protects the WT<sub>11</sub> from any fault occurring at wind farm, inter-tie or grid. Among these faults, only F1 faults are forward faults whilst other faults i.e. F2–F4 and F5/F6 faults are backward faults. Many directional relays normally operate using the fundamental phasors voltage and current, the negative- or zero-sequence components. However, the direction relay using the fundamental phasor voltage and current has the voltage dead zone for close-up faults, whilst those using the negative- or zero-sequence components cannot respond to all types of faults.

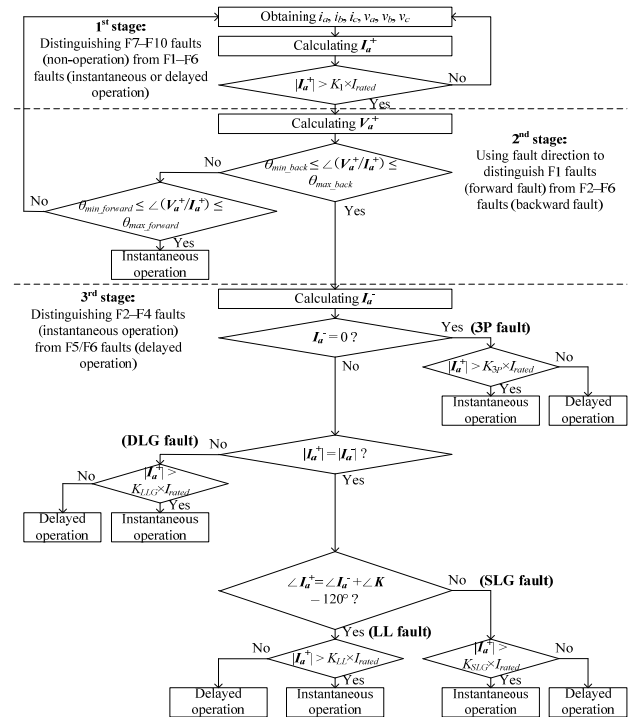

Figure 2 Flow chart of the proposed algorithm.

A directional algorithm based on the positive-sequence fault components [8] is used in this paper. This algorithm is suitable for any type of fault, has no voltage dead zone for close-up faults and can hold their fault direction decision stably.

### 3.3 Stage 3: Distinguishing F2–F4 Faults from F5/F6 Faults

In this stage, the proposed relay discriminates F2–F4 faults (instantaneous operation) from F5/F6 faults (delayed operation). The magnitude of the fault current depends on the fault position and the fault type. In other words, the fault currents even with the same type of fault are different at different fault positions and the fault currents even at the same fault position are different with different fault type. For example, the fault current for the F5\_3P fault can be larger than that of F4\_LL fault. Thus, in this paper, the fault type is evaluated first to discriminate F2–F4 faults from F5/F6 faults.

Conventionally, the zero-sequence current has been used to distinguish the grounded fault and the phase-to-phase fault. However, it is unable to evaluate the four kinds of fault types, i.e. SLG, LL, DLG or 3P. In addition, the zero-sequence current does not flow through the relaying point due to the grounded-wye-delta connection of the step-up transformers in the configuration of the wind farm as shown in Fig. 1.

Thus, in this paper, an algorithm to evaluate the type of fault based on the positive- and negative-sequence fault components at the relaying point rather than those at the fault point is developed. The algorithm can distinguish four types of faults. Table 2 shows the relationships of the symmetrical currents at the fault point and the relaying point depending on type of fault. Because the fault current at the fault point is unavailable, the relationships of the symmetrical components at the relaying point are used to evaluate the fault type. From Table 2, it can be concluded that:

- 1) when an SLG fault occurs at F2–F6, the magnitude of the positive-sequence fault component equals to that of the negative-sequence fault component, and the phase angle difference between these two components are  $60^\circ$ ,  $-60^\circ$  or  $180^\circ$ , which depends on the phase involved in the fault and the chosen reference frame.
- 2) when an LL fault occurs at F2–F6, the magnitude of the positive-sequence fault component equals to that of the negative-sequence fault component, and the phase angle difference between these two components are  $-120^\circ$ ,  $120^\circ$  or  $0^\circ$ , depending on the phase involved in the fault and the chosen reference frame.

**Table 2** Relationships of the symmetrical currents at the fault point and the relaying point for four types of faults.

Fault type	Currents (Fault point)	Currents (Relaying point)
SLG	$I_{Faf}^+ = KI_{Faf}^- = K^2 I_{Faf}^0$	$I_{Raf}^+ = KI_{Raf}^-$
LL	$I_{Faf}^+ + KI_{Faf}^- = 0$	$I_{Raf}^+ + KI_{Raf}^- = 0$
DLG	$I_{Faf}^+ + KI_{Faf}^- + K^2 I_{Faf}^0 = 0$	$I_{Raf}^+ + gKI_{Raf}^- = 0$
3P	$I_{Faf}^- = I_{Faf}^0 = 0$	$I_{Raf}^- = 0$

- 3) when a DLG fault occurs at F2–F6, the magnitude of the positive-sequence fault component is larger than that of the negative-sequence fault component.
  - 4) when a 3P fault occurs, there is no negative-sequence fault component flowing through the relaying point.
- Since the type of fault is evaluated, for each type of fault,

the magnitude of the positive-sequence fault component can be used to distinguish the faults at F2–F4 or F5/F6. Hence, the relay for a WTG can decide an appropriate operation i.e. delayed operation or instantaneous operation.

## 4 Case studies

To verify the performance of the proposed algorithm, a wind farm as shown in Fig. 1 is modeled using the EMTP-RV simulator. The configuration of the wind farm was mentioned in Section 2. The sampling rate is 64 samples/cycle.

The performance of the algorithm is verified under the various fault conditions with the fault positions (F1–F4, F5–F6, F7–F10), the types of faults (SLG, LL, DLG and 3P fault), and the faulted phases. Among them, the results of two cases, i.e. an SLG fault at F2 (the instantaneous operation) and an SLG fault at F5 (the delayed operation region) are shown in this paper.

### 4.1 A-phase SLG fault occurs at F2 (F2\_AG)

Fig. 3 shows the results for this case, where an A-phase SLG fault occurs at Feeder I at 33.33 ms. The 3P currents (i.e.,  $i_{a\_WT11}$ ,  $i_{b\_WT11}$ , and  $i_{c\_WT11}$ ) measured at the terminal of WT<sub>11</sub>, connected to the faulted feeder, are shown in Fig. 3a, where the solid, dashed, and dotted lines represent  $i_{a\_WT11}$ ,  $i_{b\_WT11}$ , and  $i_{c\_WT11}$ , respectively. The 3P currents (i.e.,  $i_{a\_WT21}$ ,  $i_{b\_WT21}$ , and  $i_{c\_WT21}$ ) measured at the terminal of WT<sub>21</sub>, connected to the healthy feeder, are shown in Fig. 3b. In Fig. 3c, the solid line shows the magnitude of the positive-sequence fault component ( $|I_{a\_WT11}^+|$ ) calculated from  $i_{a\_WT11}$ ,  $i_{b\_WT11}$ , and  $i_{c\_WT11}$ , and the dashed line shows that ( $|I_{a\_WT21}^+|$ ) calculated from  $i_{a\_WT21}$ ,  $i_{b\_WT21}$ , and  $i_{c\_WT21}$ . In the current paper, both  $|I_{a\_WT11}^+|$  and  $|I_{a\_WT21}^+|$  are shown with per unit quantities. The two dashed-dotted lines show the thresholds of two magnitude detectors, where  $K_1$  and  $K_{SLG}$  are set to be 1 and 2 p.u., respectively.

In this case, because the SLG fault occurs at Feeder I,  $|I_{a\_WT11}^+|$  significantly increases, whereas  $|I_{a\_WT21}^+|$  does not, due to the large impedance of an FCL and a step-up transformer. Thus, as mentioned in Section 3, the magnitude of the positive-sequence fault component of WT<sub>21</sub>, which is connected to an adjacent healthy feeder, increases but not enough to detect a fault. Therefore, the WT<sub>21</sub> relay does not operate, which means that the proposed WTG protection algorithm does not operate for an adjacent feeder fault.

Figs. 3d, 3e, 3f and 3g show  $\theta_{direction}$ ,  $|I_{a\_WT11}^-|$ ,  $|I_{a\_WT11}^+|/|I_{a\_WT11}^-|$  and  $\theta_{diff}$ , respectively. Because the fault occurs at F2,  $\theta_{direction}$  goes into the operation region for the backward fault. Since the fault is an unbalanced fault,  $|I_{a\_WT11}^-|$  increase significantly. The fault is judged to be an SLG or LL fault, as  $|I_{a\_WT11}^+|/|I_{a\_WT11}^-|$  is nearly one. From Fig. 3g,  $\theta_{diff}$  is larger than  $30^\circ$  and smaller than  $90^\circ$ , which proves that the fault is an SLG fault.

From Fig. 3c, because  $|I_{a\_WT11}^+|$  is larger than  $K_{SLG}$ , an instantaneous trip is activated. Fig. 3h shows the magnitude detector output, fault direction detector output and

instantaneous trip signal, respectively, from top to bottom. This case is a connected feeder fault, where the relay should operate instantaneously. Thus, the first output signal is activated at 38.02 ms, where the magnitude of the positive sequence current exceeds the threshold; the second signal is activated at 44.79 ms since the fault is a backward fault; the third signal is activated at 60.94 ms since the fault requires the instantaneous trip response.

#### 4.2 A-phase SLG fault at F5 (F5\_AG)

Fig. 4 shows the results for this case, where an A-phase SLG fault occurs at the inter-tie at 33.33 ms, and the relay should operate with a delay. In Figs. 4a and 4b,  $i_{a\_WT11}$ ,  $i_{b\_WT11}$  and  $i_{c\_WT11}$  are larger than those prior to the fault, and both  $|I_{a\_WT11}^+|$  and  $|I_{a\_WT21}^+|$  exceed  $K_1$ . However, due to the impedance of the main transformer in the substation, these cannot exceed  $K_{SLG}$ , as seen in Fig. 4b. Figs. 4c, 4d, 4e and 4f show that the proposed protection algorithm correctly evaluates the fault as an SLG fault. In Fig. 4g, the first and second output signals are activated at 41.41 and 46.35 ms, respectively. The delayed operation signal is activated at 62.50 ms. Finally, the delayed trip signal is activated at 362.50 ms. In the current paper, the coordination time is set to 300 ms, which is commonly used in distribution system protection. The results indicate that when an inter-tie fault occurs, a delayed operation signal rather than an instantaneous operation signal is activated successfully.

## 5 Conclusion

A protection relay for a WTG in a large wind farm based on the positive- and negative-sequence fault components was proposed in the paper. An internal fault of another WTG connected to the same feeder or an adjacent feeder fault, where the relay should not operate, is discriminated based on the magnitude of the positive-sequence fault component. An internal fault, where the relay should operate instantaneously, is distinguished by a directional algorithm based on the positive-sequence fault components. The relationships between the positive- and negative-sequence fault components, which depend on type of fault, are used to distinguish the fault type i.e. SLG, LL, DLG or 3P first. Then, the magnitude of the positive-sequence fault component is used to decide either instantaneous or delayed operation.

The simulation results clearly indicate that the proposed WTG protection relay can successfully distinguish an instantaneous, delayed or non-operation depending on fault positions, irrespectively of type of fault and the phases involved in the fault. The proposed relay can minimize the outage section, and the undesirable disconnection of the whole large wind farm or some healthy WTGs can be avoided.

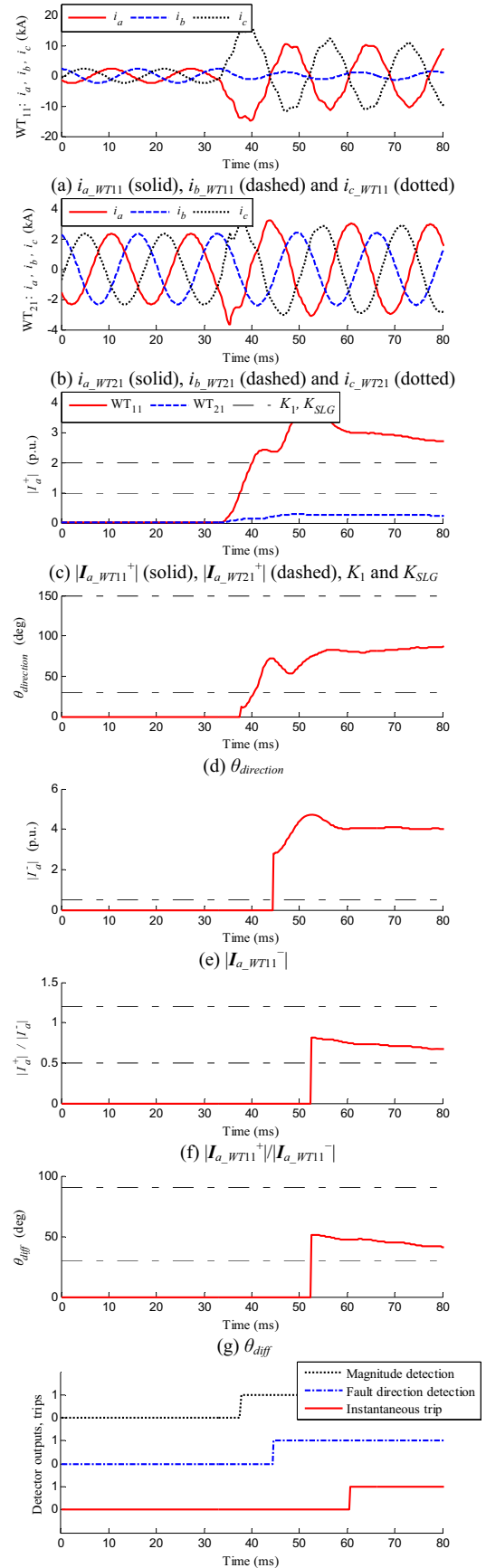

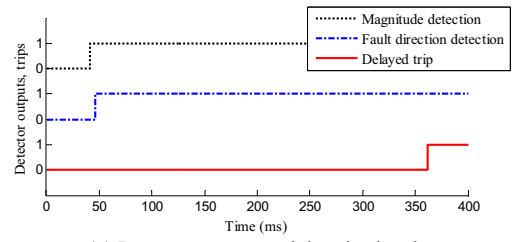
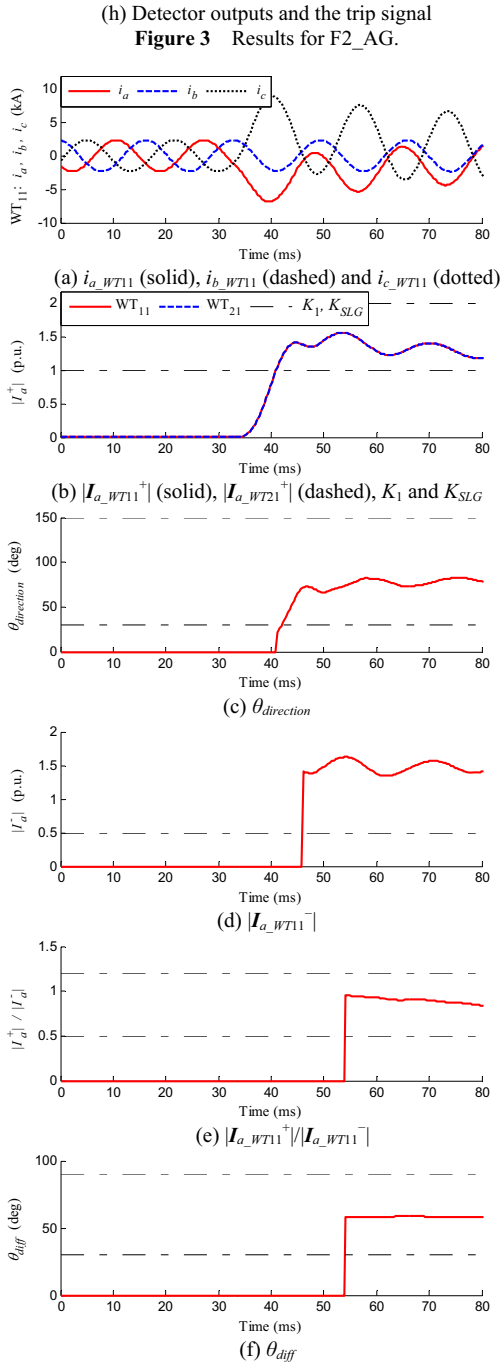

This research was supported by Basic Science Research Program through the National Research Foundation of Korea (NRF) funded by the Ministry of Education, Science and Technology (2010-0029426).

- 1 Haslam, S.J., Crossley, P.A., Jenkins, N.: ‘Design and field testing of a source based protection relay for wind farms’, *IEEE Trans. on Power Deliv.*, 1999, **14**, (3), pp. 818–823
- 2 Haslam, S.J., Crossley, P.A., Jenkins, N.: ‘Design and evaluation of a wind farm protection relay’, *IEE Proc. -Gener. Transm. Distrib.*, 1999, **146**, (1), pp. 37–44
- 3 Pradhan, A.K., Joós, G.: ‘Adaptive distance relay setting for lines connecting wind farms’, *IEEE Trans. on Energy Conversion*, 2007, **22**, (1), pp. 206–213
- 4 GE Consumer & Industrial Multilin, W650-Wind generator protection system instruction manuals, 2006 GE Multilin. [online]. Available: <http://www.gedigitalenergy.com/app/ViewFiles.aspx?prod=w650&type=3>
- 5 Schweitzer Engineering Laboratories, SEL-700GW wind generator relay. [online]. Available: <http://www.selinc.com/sel-700gw/>
- 6 Parashar, R., Sasse, C., Banks, R., Falkingham, L.: ‘Fault current limiters for transmission & distribution networks’, in *18<sup>th</sup> International Conference on Electricity Distribution*, Turin, Italy, 2005
- 7 Khan, U.A., Seong, J.K., Lee, S.H., Lim, S.H., Lee, B.W.: ‘Feasibility analysis of the positioning of superconducting fault current limiters for the smart grid application using Simulink and SimPowerSystem’, *IEEE Transactions on Applied Superconductivity*, to be published
- 8 Wind Plant Collector Design WG, “Wind power plant grounding, overvoltage protection, and insulation coordination,” in *Proc. 2009 IEEE Power and Energy Society General Meeting*, Calgary, Canada, Jul. 2009.
- 9 Wind Plant Collector Design WG, “Wind power plant substation and collector system redundancy, reliability, and economics,” in *Proc. 2009 IEEE Power and Energy Society General Meeting*, Calgary, Canada, Jul. 2009.
- 10 Gao, H., Crossley, P.A.: ‘Design and evaluation of a directional algorithm for transmission-line protection based on positive-sequence fault components’, *IEE Proc. -Gener. Transm. Distrib.*, 2006, **153**, (6), pp. 711–718
- 11 Samman, N., Zavadil, R., Smith, J.C., Conto, J.: ‘Modeling of wind power plants for short circuit analysis in the transmission network’, in *Proc. Of IEEE/PES Transmission and Distribution Conference*, Chicago, USA, Apr. 2008.