

Technical University of Denmark



Matched-filtering generalized phase contrast using LCoS pico-projectors for beam-forming

Bañas, Andrew Rafael; Palima, Darwin; Glückstad, Jesper

Published in:
Optics Express

Link to article, DOI:
[10.1364/OE.20.009705](https://doi.org/10.1364/OE.20.009705)

Publication date:
2012

Document Version
Publisher's PDF, also known as Version of record

[Link back to DTU Orbit](#)

Citation (APA):

Bañas, A. R., Palima, D., & Glückstad, J. (2012). Matched-filtering generalized phase contrast using LCoS pico-projectors for beam-forming. *Optics Express*, 20(9), 9705-9712. DOI: 10.1364/OE.20.009705

DTU Library

Technical Information Center of Denmark

General rights

Copyright and moral rights for the publications made accessible in the public portal are retained by the authors and/or other copyright owners and it is a condition of accessing publications that users recognise and abide by the legal requirements associated with these rights.

- Users may download and print one copy of any publication from the public portal for the purpose of private study or research.
- You may not further distribute the material or use it for any profit-making activity or commercial gain
- You may freely distribute the URL identifying the publication in the public portal

If you believe that this document breaches copyright please contact us providing details, and we will remove access to the work immediately and investigate your claim.

Matched-filtering generalized phase contrast using LCoS pico-projectors for beam-forming

Andrew Bañas, Darwin Palima, and Jesper Glückstad*

DTU Fotonik, Department of Photonics Engineering, Technical University of Denmark, Ørsteds Plads 343, DK-2800 Kgs. Lyngby, Denmark

*jesper.gluckstad@fotonik.dtu.dk

www.ppo.dk

Abstract: We report on a new beam-forming system for generating high intensity programmable optical spikes using so-called matched-filtering Generalized Phase Contrast (mGPC) applying two consumer handheld pico-projectors. Such a system presents a low-cost alternative for optical trapping and manipulation, optical lattices and other beam-shaping applications usually implemented with high-end spatial light modulators. Portable pico-projectors based on liquid crystal on silicon (LCoS) devices are used as binary phase-only spatial light modulators by carefully setting the appropriate polarization of the laser illumination. The devices are subsequently placed into the object and Fourier plane of a standard 4f-setup according to the mGPC spatial filtering configuration. Having a reconfigurable spatial phase filter, instead of a fixed and fabricated one, allows the beam shaper to adapt to different input phase patterns suited for different requirements. Despite imperfections in these consumer pico-projectors, the mGPC approach tolerates phase aberrations that would have otherwise been hard to overcome by standard phase projection.

© 2012 Optical Society of America

OCIS codes: (070.6110) Spatial filtering; (140.3300) Laser beam shaping; (100.1390) Binary phase-only filters; (070.6120) Spatial light modulators.

References:

1. D. Palima, A. R. Bañas, G. Vizsnyiczai, L. Kelemen, P. Ormos, and J. Glückstad, "Wave-guided optical waveguides," *Opt. Express* **20**(3), 2004–2014 (2012).
2. J. Glückstad, D. Palima, J. S. Dam, and I. Perch-Nielsen, "Dynamically reconfigurable multiple beam illumination based on optical correlation," *J. Opt. A, Pure Appl. Opt.* **11**(3), 034012 (2009).
3. I. Perch-Nielsen, D. Palima, J. S. Dam, and J. Glückstad, "Parallel particle identification and separation for active optical sorting," *J. Opt. A, Pure Appl. Opt.* **11**(3), 034013 (2009).
4. J. Glückstad and D. Palima, "Combining Generalized Phase Contrast with matched filtering into a versatile beam shaping approach," *J. Phys.: Conf. Ser.* **206**, 012006 (2010).
5. J. Glückstad and D. Palima, "Generalized Phase Contrast: Applications in Optics and Photonics", Springer Series in Optical Sciences, Vol. **146**, 310 pp (2009).
6. T. Čížmár, M. Mazilu, and K. Dholakia, "In situ wavefront correction and its application to micromanipulation," *Nat. Photonics* **4**(6), 388–394 (2010).
7. R. Bowman, V. D'Ambrosio, E. Rubino, O. Jedrkiewicz, P. Trapani, and M. J. Padgett, "Optimisation of a low cost SLM for diffraction efficiency and ghost order suppression," *Eur. Phys. J. Spec. Top.* **199**(1), 149–158 (2011).
8. J. L. Martínez, A. Martínez-García, and I. Moreno, "Wavelength-compensated color Fourier diffractive optical elements using a ferroelectric liquid crystal on silicon display and a color-filter wheel," *Appl. Opt.* **48**(5), 911–918 (2009).
9. S. Mias, I. G. Manolis, N. Collings, T. D. Wilkinson, and W. A. Crossland, "Phase-modulating bistable optically addressed spatial light modulators using wide-switching-angle ferroelectric liquid crystal layer," *Opt. Eng.* **44**(1), 014003 (2005).
10. A. Martínez, N. Beaudoin, I. Moreno, M. D. M. Sánchez-López, and P. Velásquez, "Optimization of the contrast ratio of a ferroelectric liquid crystal optical modulator," *J. Opt. A, Pure Appl. Opt.* **8**(11), 1013–1018 (2006).
11. R. W. Gerchberg and W. O. Saxton, "A practical algorithm for the determination of the phase from image and diffraction plane pictures," *Optik (Stuttg.)* **35**, 237 (1972).
12. M. Guizar-Sicairos and J. C. Gutiérrez-Vega, "Computation of quasi-discrete Hankel transforms of integer order for propagating optical wave fields," *J. Opt. Soc. Am. A* **21**(1), 53–58 (2004).

13. J. Yamamoto and T. Iwai, "Spatial Stability of Particles Trapped by Time-Division Optical Tweezers," *Int. J. Optomechatronics* **3**(4), 253–263 (2009).
 14. H. Ulriksen, J. Thogersen, S. Keiding, I. R. Perch-Nielsen, J. S. Dam, D. Z. Palima, H. Stapelfeldt, and J. Glückstad, "Independent trapping, manipulation and characterization by an all-optical biophotonics workstation," *J. Eur. Opt. Soc. Rapid Publ.* **3**, 08034 (2008).
 15. A. Bañas, D. Palima, F. Pedersen, and J. Glückstad, "Development of a compact Bio-Optofluidic Cell Sorter," *Proc. SPIE* **8274**, 1–6 (2012).
-

1. Introduction

The ability to dynamically shape light distributions has many applications in research, industry and even in everyday consumer applications. In research, light modulation is widely applied to microscopy, optical manipulation, and light-based micro-fabrication among others [1]. In more common settings, spatial light modulators in the form of digital micro-mirror devices (DMD) or liquid crystal on silicon (LCoS) are used in display projectors. Conceptually, the simplest light modulation technique is based on amplitude modulation wherein light is allowed to transmit to define the desired patterns and be deflected or absorbed where it is supposed to be dark. This simplicity comes at the cost of low overall photon efficiency. Phase modulation methods, on the other hand, rely on interference and diffraction to redistribute light from dark to bright regions, hence, in principle, conserving the available amount of photons from the light source. To dynamically modulate phase, programmable spatial light modulators (SLMs) are used in conjunction with techniques such as computer generated holography based on Fourier diffraction or Generalized Phase Contrast (GPC). More recently light shaping based on so-called Matched filtering GPC (mGPC) has been demonstrated using phase-only input and phase-only correlation filters adapting the standard GPC into a so-called phase correlation-type configuration [2–5]. Instead of using correlation or matched filtering to locate target patterns in an input scene, mGPC is used in reverse, such that phase correlation target patterns are used to deliberately control real-time reconfigurable light spikes at the optical output.

Paralleled by the development of light shaping methods is the introduction of light modulating devices. A lot of research on optical modulation and manipulation has been made possible with the introduction of phase-only spatial light modulators primarily based on parallel-aligned liquid crystals. These phase-only SLMs are manufactured to meet research requirements having as many phase levels as possible and imparting minimal wavefront aberrations. Even if aberrations do exist, these can be somewhat corrected for due to the SLM's programmability and the availability of a plurality of calibrated phase levels.

Despite these phase-only SLMs being 'ideal' light-modulating devices, interest on using mass-produced liquid crystal on silicon devices intended for consumer display projectors have been growing as they promise a much cheaper and readily available alternative. The recent emergence of handheld "pico"-projectors have lowered the cost even further. As expected, however, LCoS-devices used in consumer projectors need not be free from phase aberrations as they project images based on amplitude modulation of incoherent light. This simpler light shaping mode lessens manufacturing constraints and allows the use of common incoherent light sources such as LEDs or lamps. As they are intended for real-time video display, calculating intermediate patterns different from the target output, such as for computer generated holograms, would make the device costly with additional processing units. When used as a phase-only modulator, the phase aberrations on these devices can no longer be ignored. An aberration correction similar to that used in high-end or multilevel phase SLMs is also not possible to implement as the LCoS's pixels can typically only switch between two states (gray levels are achieved by time integration) [6]. In a 2f configuration, the additional phase aberrations would degrade the point spread function in the spatial Fourier plane. Nevertheless, these shortcomings have not prevented researchers from using LCoS devices for computer generated holography accepting compromises in the fidelity achieved [7–9].

In this work, we use so-called matched-filtering Generalized Phase Contrast, mGPC, to work around the problems of phase aberrations in low-cost LCoS devices while maintaining the computational simplicity of GPC. In previous works, mGPC was demonstrated using

high-end SLMs [2–3]. Here, we show that mGPC can be used to create dynamic and high-intensity optical spikes despite phase aberrations in these pico-projector LCoS devices. Similar to GPC, the mGPC approach does not suffer from a strong un-diffracted zeroth order and is not computationally intensive (only a lookup table is required). Using a matched Fourier phase filter that behaves like a correlating filter, local input phase patterns are highlighted against any distorted phase background, as shown in Fig. 1. Furthermore, we also apply an LCoS device as mGPC phase-only filter removing the need of a fabrication facility and making a more versatile beam shaper by having a tunable spatial phase filter that can adapt and optimally correlate with different input phase patterns.

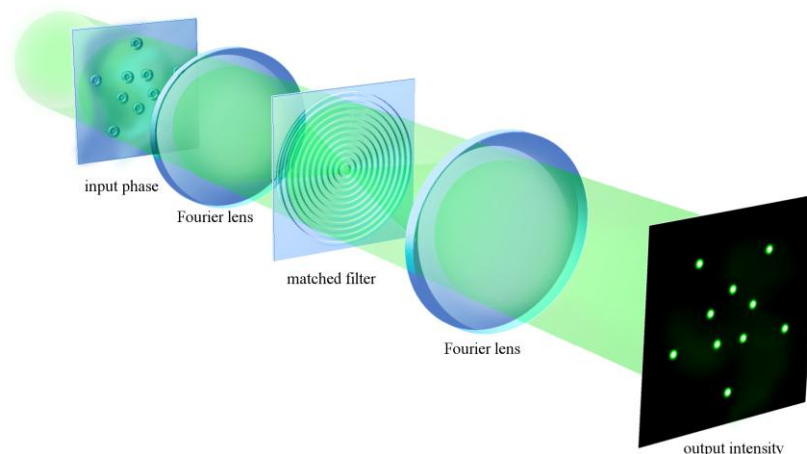

Fig. 1. The matched-filtering Generalized Phase Contrast (mGPC) setup. High intensity spots corresponding to desired correlation target patterns are generated at the output despite mild phase distortions at the input phase.

Section 2 briefly describes how the applied pico-projector LCoS devices are operated as simple binary phase modulators. With these low-cost binary phase modulators at hand, the rest of the sections discuss the demonstration of mGPC implemented on these devices.

2. Pico-projector LCoS device operated as binary-phase spatial light modulator

Our optical characterization, described in the following, shows that the LCoS device from the picoprojector behaves as an array of programmable half-wave plates that can alter the polarization of light reflected from each pixel. In conventional operation – as amplitude modulator – it uses incident linear polarization, which is either maintained or rotated by 90° upon reflection depending on the pixel's state. A polarizer placed after the LCoS device blocks light with unmodified polarization and transmits the rotated polarization to create spatial intensity modulation. We have found that phase-only modulation can be achieved from such an LCoS device by rotating the incident polarization by -45° , where maximum angular variation is obtained with the LC director axis when switched between its binary states.

We performed experiments to identify the necessary polarizations for both amplitude and phase modulation. The experiments utilized an 800×600 pixel LCoS device manufactured by Syndiant (SYL2043) that comes with the Aiptek T25 PocketCinema projector. The measured pixel pitch of the LCoS is $9.5\mu\text{m}$. The schematic of the setup is shown in Fig. 2. A $\lambda/2$ waveplate turns the linear polarization of a collimated and expanded laser beam (532nm Excel, Laser Quantum), which is incident on the LCoS device through a beam splitter. The beam splitter redirects light coming from the LCoS through an analyzer (P) and a 4f setup consisting of two $f = 300\text{mm}$ lenses that images the LCoS device plane onto a CCD camera.

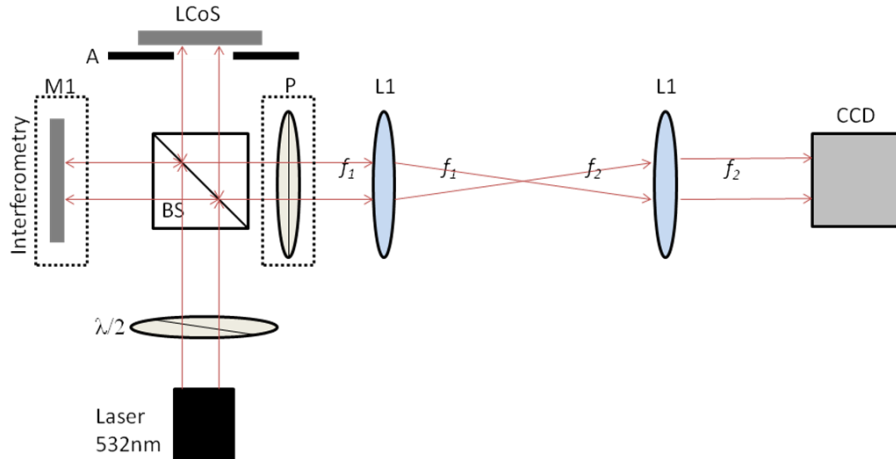

Fig. 2. The setup used for analyzing amplitude and phase modulation modes of the applied LCoS device. The analyzer, P, is used to visualize amplitude modulation while the mirror, M1, is used to visualize phase modulation.

The LCoS projector's amplitude modulation scheme is replicated when the incident polarization is either at 90° (vertical) or 0° (horizontal), and the analyzer is perpendicular to it (0° or 90° respectively) (i.e. Figure 3(a)). This suggests that the LCoS device can act as a phase modulator when the incident polarization is at -45° [10].

To verify the achieved phase modulation, the setup can be converted to a phase-imaging Michelson-like interferometer by removing the analyzer and adding a mirror, labeled M1 in Fig. 2, to direct a collimated reference beam to the camera through the 4f setup. With the LCoS plane sharply imaged at the camera, the resulting interference fringes enable visualization of any resulting spatial phase modulation. For comparison, we start with an amplitude-modulation configuration and record the striped pattern as shown in Fig. 3.a. While maintaining the same pattern on the LCoS device, we shift to an interferometric geometry and observe that rotating the incident polarization at -45° achieves the desired spatial phase modulation behavior as exemplified by the shifted fringes between the regions creating the black and white stripes when the LCoS device is used for amplitude-modulation (Fig. 3(b)).

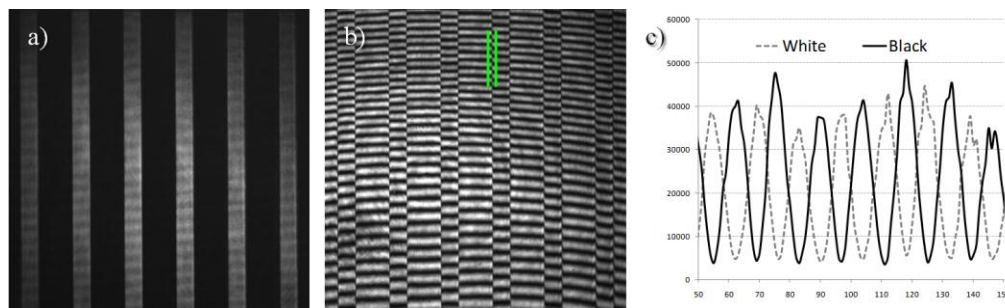

Fig. 3. Vertical stripes displayed via normal LCoS-projector operation showing amplitude modulation (a). Corresponding fringes in phase modulation mode obtained using a mirror for the reference wave (b). Line scans taken from the green highlights in (b) show the phase difference between stripes encoded with black and white (c).

3. Intuitive picture of the mGPC beam-forming principle

Looking at the spatial Fourier plane, a matched filter acts by changing the phase of the diffracted input into a planar phase. Using several copies of the correlation target patterns (cTP) at the input creates an array of output spots that resemble focused plane waves. Hence,

we can, to some extent, picture the role of the correlation target pattern and corresponding matched filter as effectively creating dynamic “Fresnel” lenses, as depicted in Fig. 4 together with the Fourier lenses. In effect, an incoming collimated light can be transformed into reconfigurable spots at the output, which mimic the focusing achieved by a reconfigurable array of microlenses. We have explored ways to improve this focusing effect, as described in the following, and then tested experimentally using the picoprojector LCoS device, as described in section 4.

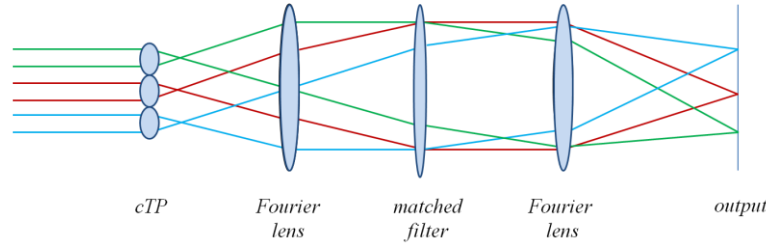

Fig. 4. A lens system acting as an mGPC optical setup. A lenslet array takes the role of the correlation target patterns and a lens that flattens the phase takes the role of the matched filter.

3.1 Calculating the correlation target pattern and the matched filter

First we tried the mGPC setup with simple circular binary-phase correlation target patterns. Light having a uniform amplitude with a binary tophat phase distribution produces a focus that is similar to an Airy function in addition to a zero-order beam. Hence, a matched phase filter should contain concentric circles with binary phase alternating between 0 and π and a central π -phase disk corresponding to the zero-order.

By restricting the cTP’s symmetry to being even or odd, its Fourier transform can be purely real or purely imaginary. This then means that the function only has two relative phase values corresponding to changes in its sign, 0 or π . Adopting simple Fourier optics, a matched phase-only filter transfer function having the phase, ϕ , can be immediately obtained by

$$e^{i\phi} = \text{sgn}(F\{u_{cp}\}) \quad (1)$$

Here u_{cp} defines the input field with the correlation target pattern at the optical axis, F is the Fourier transform operator and sgn is the sign function. This filter phase distribution effectively “rectifies” the Fourier distribution, giving it a planar phase and hence focusing to a sharp spike at the output. The superposition and shift properties of the Fourier transform extends the principle to a multi-spot case, enabling dynamic control of a plurality of simultaneous high intensity spots.

3.2. Increasing peak intensities using the Gerchberg Saxton method

To emulate plane-wave focusing as much as possible, the cTP should be designed such that the amplitude distribution at the focal plane is close to uniform. This ensures that higher frequency components necessary to define sharp features optimally contribute in the formation of the output spots. The Airy like diffraction resulting from an input with a tophat phase has most of its energy centered around the zero-order and the surrounding central lobe. Knowing how the amplitude distributions should ideally look like at both the input and Fourier planes, a phase retrieval algorithm such as the Gerchberg Saxton (GS) algorithm [11] can be used as design tool. The GS algorithm iterates between the object and Fourier plane, keeping the phase at each transform while applying the desired amplitude constraints. When circular patterns are used, the 2D Fourier transforms involved in the iterations are simply reduced to 1D Hankel transforms [12]. Once the optimal cTP and Fourier filters are computed, they can be re-used for different cTP configurations (i.e. Figure 5).

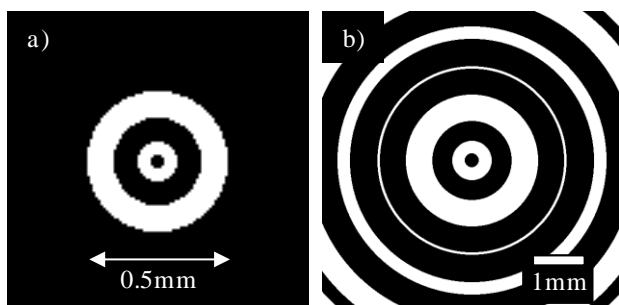

Fig. 5. Gerchberg-Saxton optimized cTP with a 53 pixel (0.5mm) diameter (a) and corresponding 600×600 pixel² (5.7×5.7 mm²) Fourier filter (b). Amplitude constraints were based on top-hats with a 26 and 300 pixel radius at the input and Fourier plane, respectively.

4. Beam-forming experiments using mGPC

With the LCoS device operated as input binary-phase spatial light modulator, the next step is to insert a phase-only spatial correlation filter at the Fourier plane in order to implement a functional mGPC setup (c.p. Figure 6). Instead of using a pre-fabricated phase filter optimized for a given cTP, a second device, LCoS2, has been applied, making it easy to reconfigure the cTP for light optimization. A second non-polarizing beam splitter is used to sample light that have gone through LCoS2. Figures 7(d) and 7(f) show the resulting optical spikes when encoding the binary Fourier phase filter (insets in Fig. 7(c) and 7(e)) on LCoS2. The resulting output for a cTP based on an input phase disk with a 53 pixel (0.5mm) diameter is shown with and without a binary Fourier phase filter encoded (Fig. 7.a and 7.b). The matched filter for this disk cTP has an Airy central lobe diameter of 0.77mm (81 pixels). For the same disk diameter an increase in the peak intensity and a narrower spike is observed when using a GS-optimized cTP and matched phase filter as shown in the superposed line scans in Fig. 7(g).

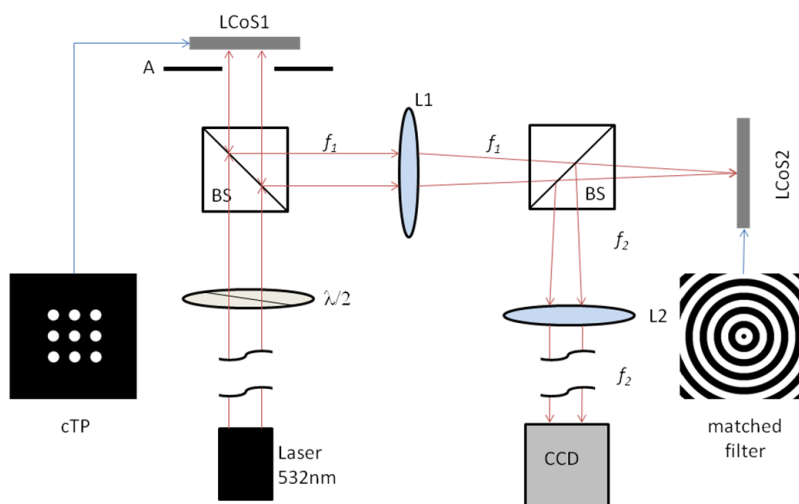

Fig. 6. The mGPC setup utilizing two pico-projector LCoS-devices for creating the desired dynamic correlation target patterns and matched binary Fourier phase filters required for beam-forming.

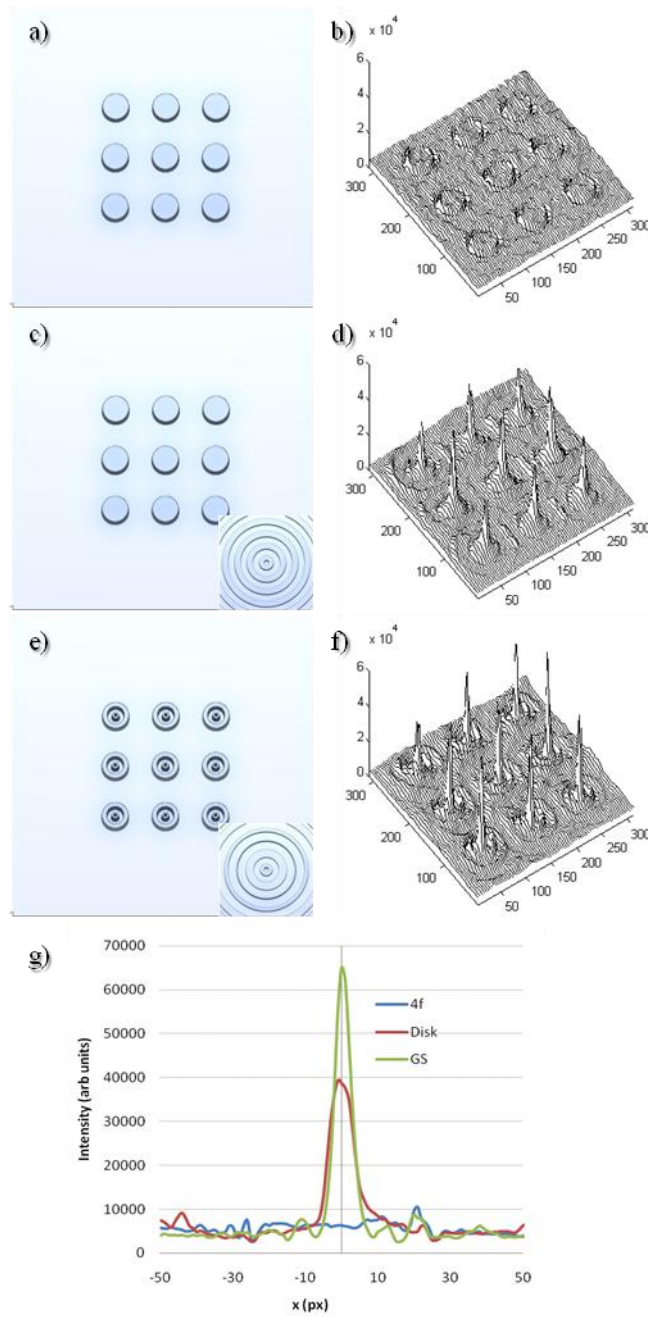

Fig. 7. Example mGPC input phase patterns consisting of 53 pixel diameter disks and the resulting output without Fourier filtering (a-b). Output with applied matched Fourier phase filtering (c-d). Output using a GS-optimized cTP with the same input diameter pattern (e-f). Line scans comparing the generated spot profiles (g). Insets in (c) and (e) show the binary-phase matched filters used.

Figure 8 shows snapshots from a video recording demonstrating the potential use for optical manipulation. The GS optimized patterns were programmed to trace a star. Although the encoded sequence used is pre-calculated, it is only necessary to translate the cTPs to move the spots around.

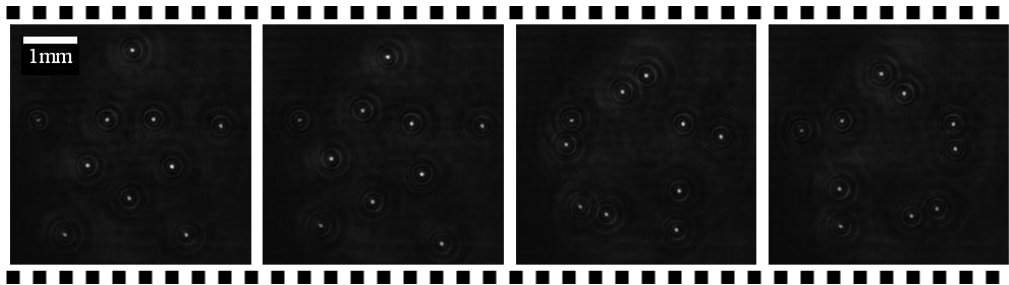

Fig. 8. [Media 1](#). Experimental snapshots from a movie sequence showing the potential for real time optical manipulation. 10 mGPC spots move along the perimeter of a star figure.

4.1 Spike intensity encoding through time integration

As cTPs only need to be translated and encoded with a different gray level, redefining the spot configurations can be done in real time. Binary phase modulation directly utilizes the LCoS projector's fast switching ($\sim 180\text{Hz}$), to produce a grayscale which is a temporal average of "on" and "off" patterns. Since video frame switching rates are far above required refresh rates for stable optical trapping and manipulation ($\sim 5\text{-}20\text{Hz}$) [13], it can be expected that this time integrated intensity modulation would not be an issue. Hence, this output intensity modulation scheme may effectively be used for 3D manipulation based on counter-propagating beam traps [14]. Figure 9(a) shows changes in encoded gray levels corresponding to changes in output intensity levels (Fig. 9(b) and 9(c)).

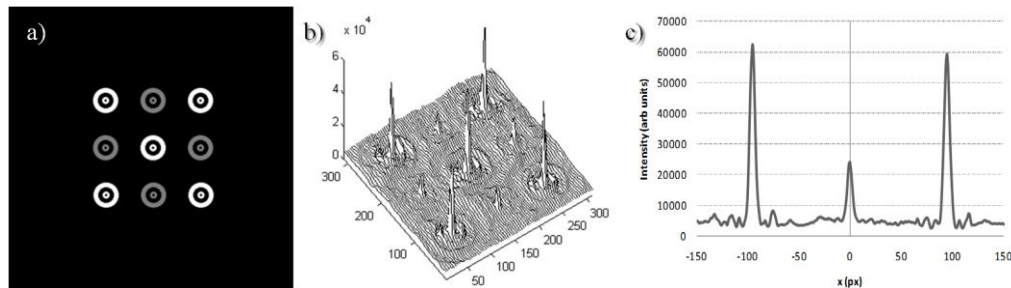

Fig. 9. Correlation target patterns optimized via the Gerchberg-Saxton algorithm wherein some of the patterns have 50% gray levels encoded (a). The resulting optical output with intensity variations corresponding to the gray-levels encoded (b and c).

5. Conclusions and outlook

We have demonstrated matched-filtering Generalized Phase Contrast (mGPC) using low-cost hand-held pico-projectors as phase spatial light modulators. The beam shaper is capable of producing high intensity spots, despite phase distortions in the backplane of the devices. This offers as an economical alternative for applications such as optical manipulation, cell sorting, pattern formation and for other beam forming uses. Future work will focus on incorporating this mGPC technique into a compact version of our BioPhotonics Workstation [14] and our Bio-Optofluidic Cell Sorter coined cell-BOCS [15].

Acknowledgments

We thank the Danish Technical Scientific Research Council (FTP) for financial support.