



Evaluation of fibre twisting angle and composite properties

Rask, Morten; Madsen, Bo

Publication date:
2011

[Link back to DTU Orbit](#)

Citation (APA):

Rask, M., & Madsen, B. (2011). Evaluation of fibre twisting angle and composite properties [Sound/Visual production (digital)]. Textiles based on natural fibers for composites applications, Poznan (PL), 22 Mar, 01/01/2011

DTU Library

Technical Information Center of Denmark

General rights

Copyright and moral rights for the publications made accessible in the public portal are retained by the authors and/or other copyright owners and it is a condition of accessing publications that users recognise and abide by the legal requirements associated with these rights.

- Users may download and print one copy of any publication from the public portal for the purpose of private study or research.
- You may not further distribute the material or use it for any profit-making activity or commercial gain
- You may freely distribute the URL identifying the publication in the public portal

If you believe that this document breaches copyright please contact us providing details, and we will remove access to the work immediately and investigate your claim.

Evaluation of fibre twisting angle and composite properties

Morten Rask and Bo Madsen

Materials Research Division, Risø National Laboratory for
Sustainable Energy, Technical University of Denmark



Composite materials

Fibres:

- Glass fibres
- Carbon fibres
- Cellulose fibres
- and more

+

Matrix:

- Polymers
- Metals
- Ceramics

=

Composite material

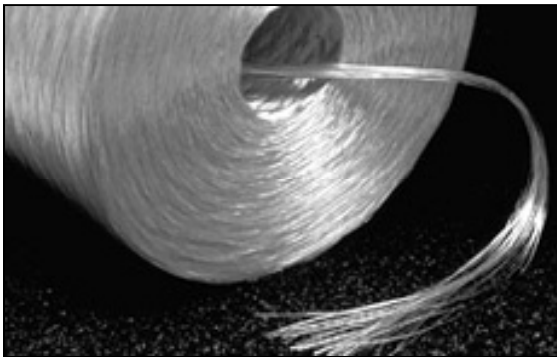
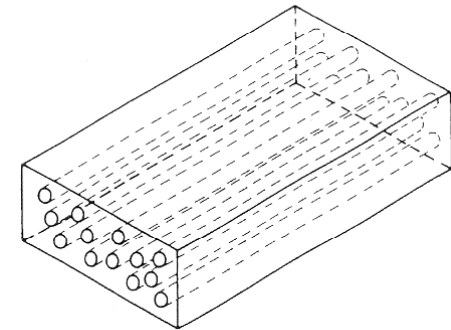

Glass fibres



Polyester matrix



Wind turbine blades made of glass/polyester composites

Composite parameters

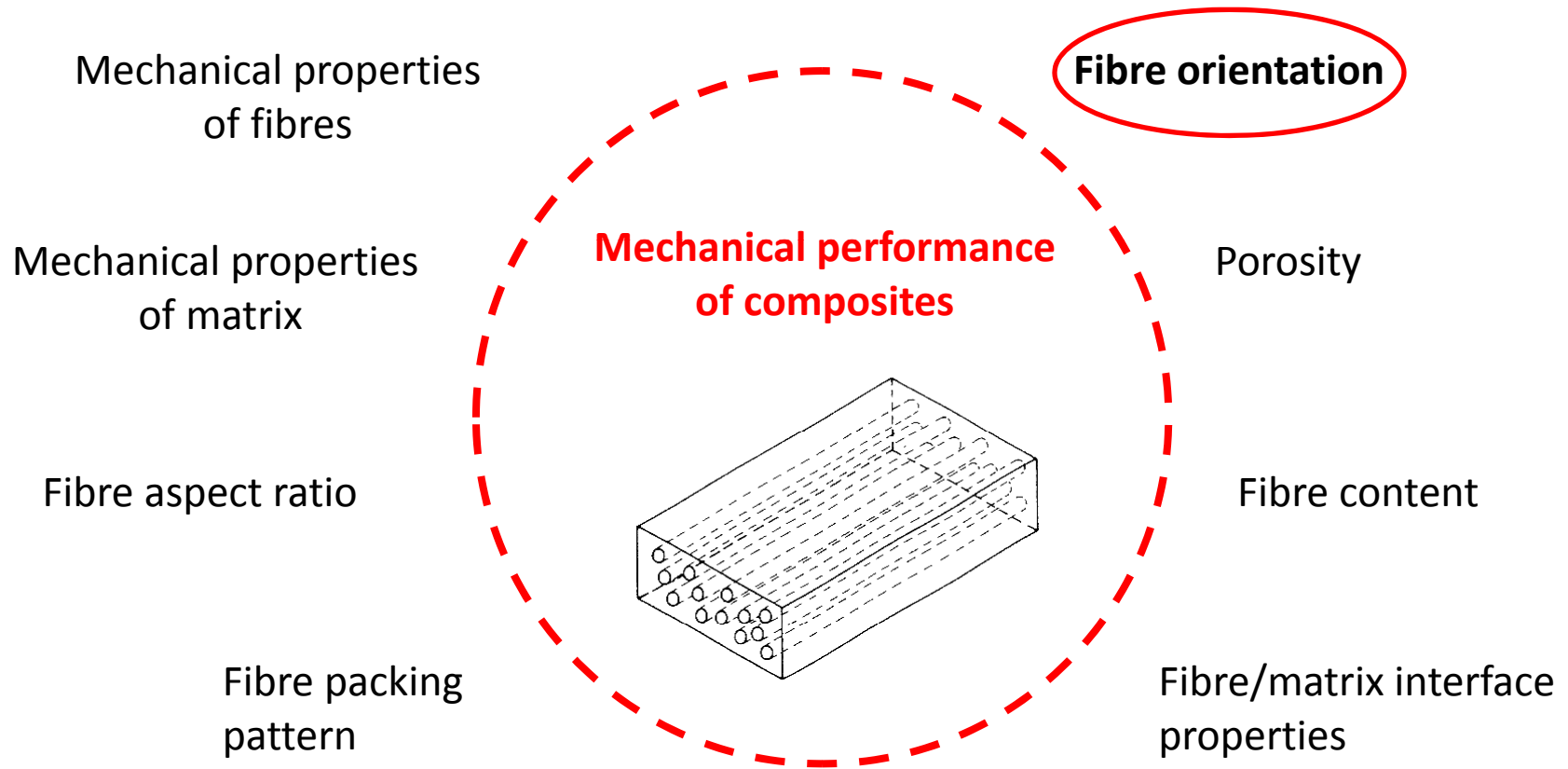

Fibre twisting in natural fibre yarns

Ring spinning

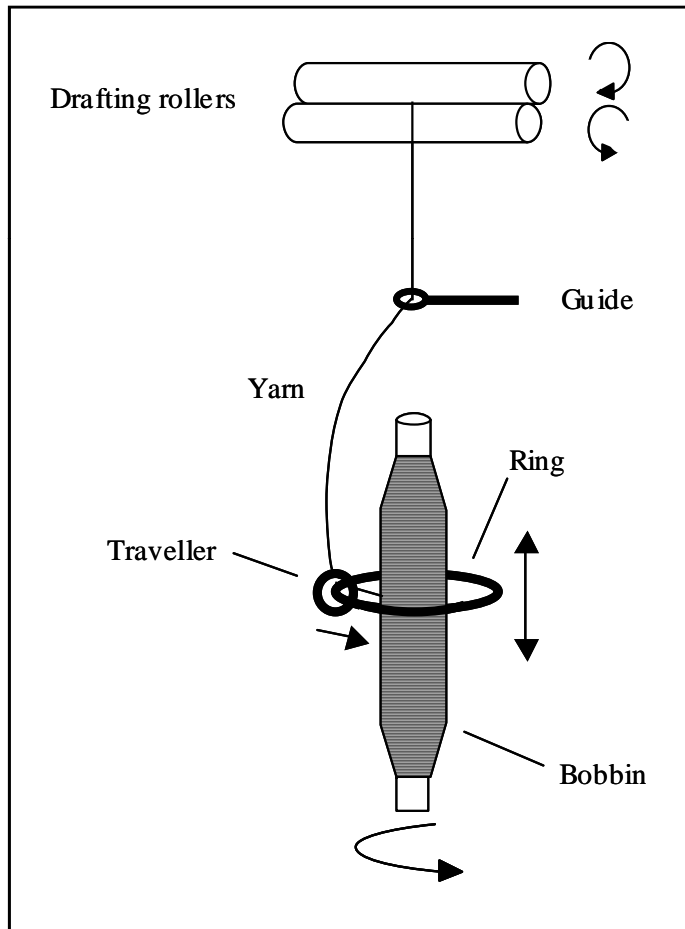

Twisted fibres in yarn (SEM image)

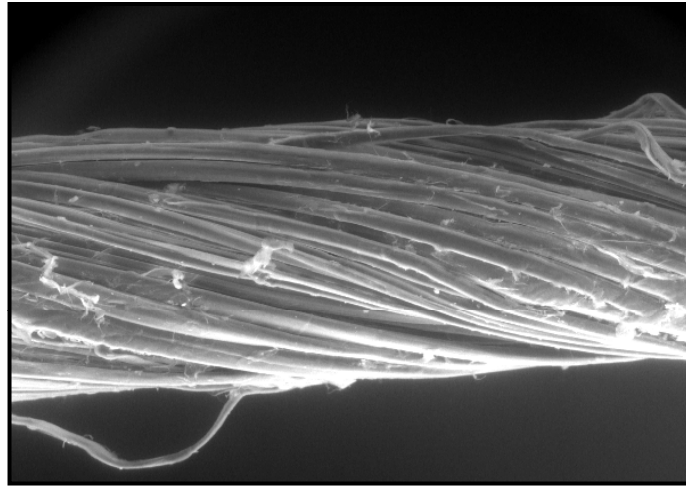

Bobbin of yarn



Fibre twisting in natural fibre yarns

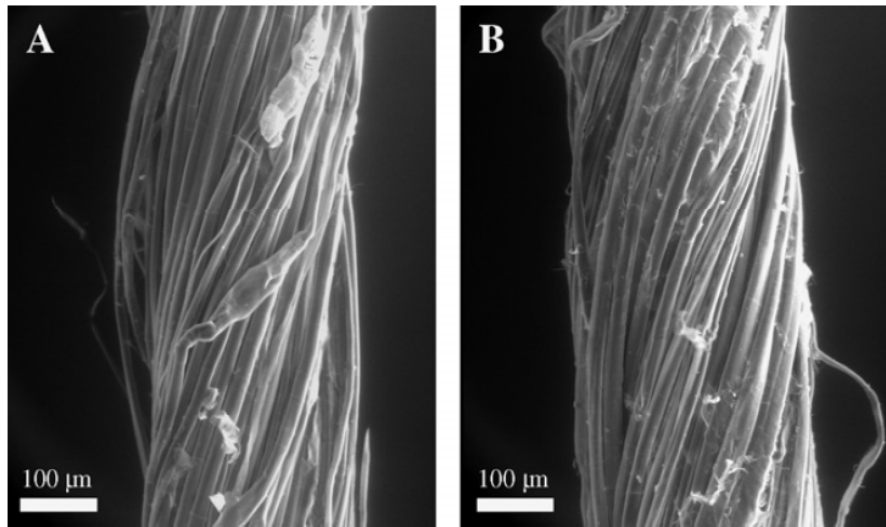

Fig. 2. Environmental scanning electron microscope images of hemp yarn: (A) is He47 and (B) is He53.

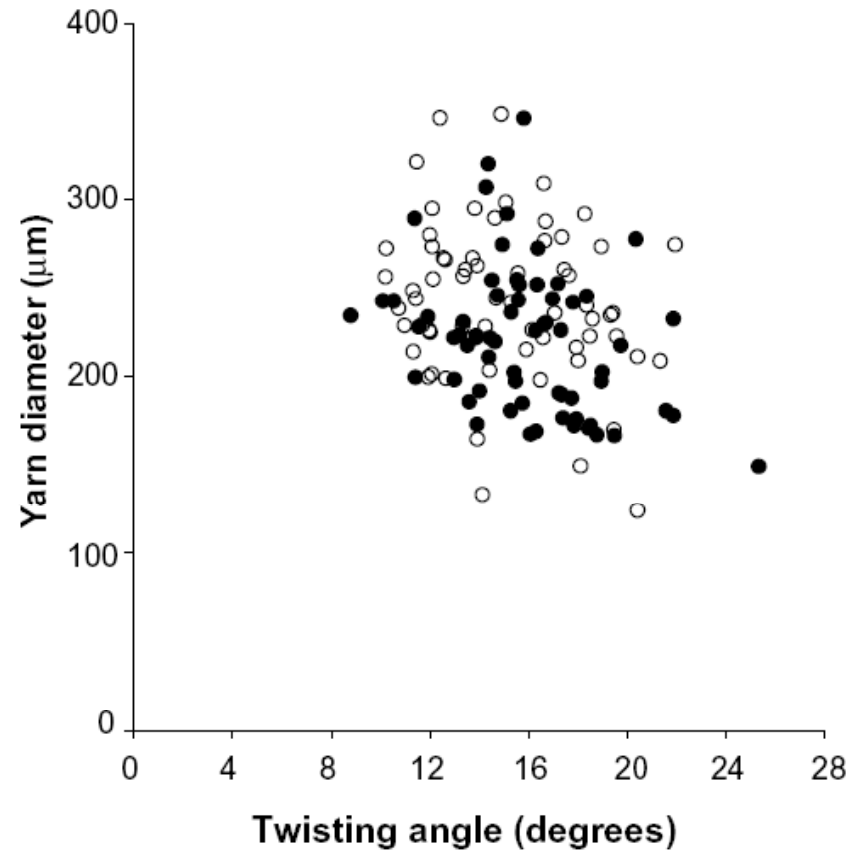
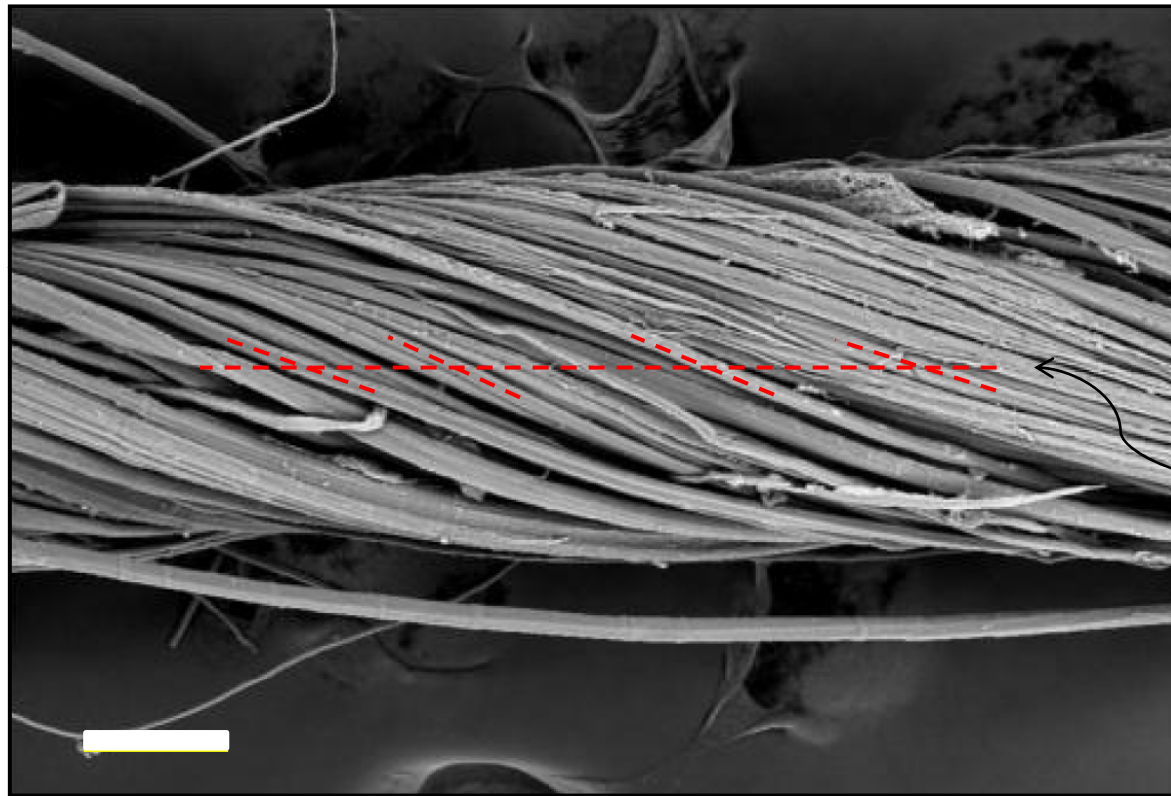

Fig. 3. Yarn diameter as a function of fibre twisting angle at the yarn surface for He47 (o) and He53 (•). Sample size is 65 for each yarn type.

Fibre twisting in natural fibre yarns



Yarn diameter: $390 \pm 90 \mu\text{m}$

Fibre twisting angle: $16 \pm 3^\circ$

Fig. 6.2. ESEM image of neat flax yarn. Scale bar is $100 \mu\text{m}$.

Source: Pegoraro (2011), NATEX project

Fibre twisting in natural fibre yarns

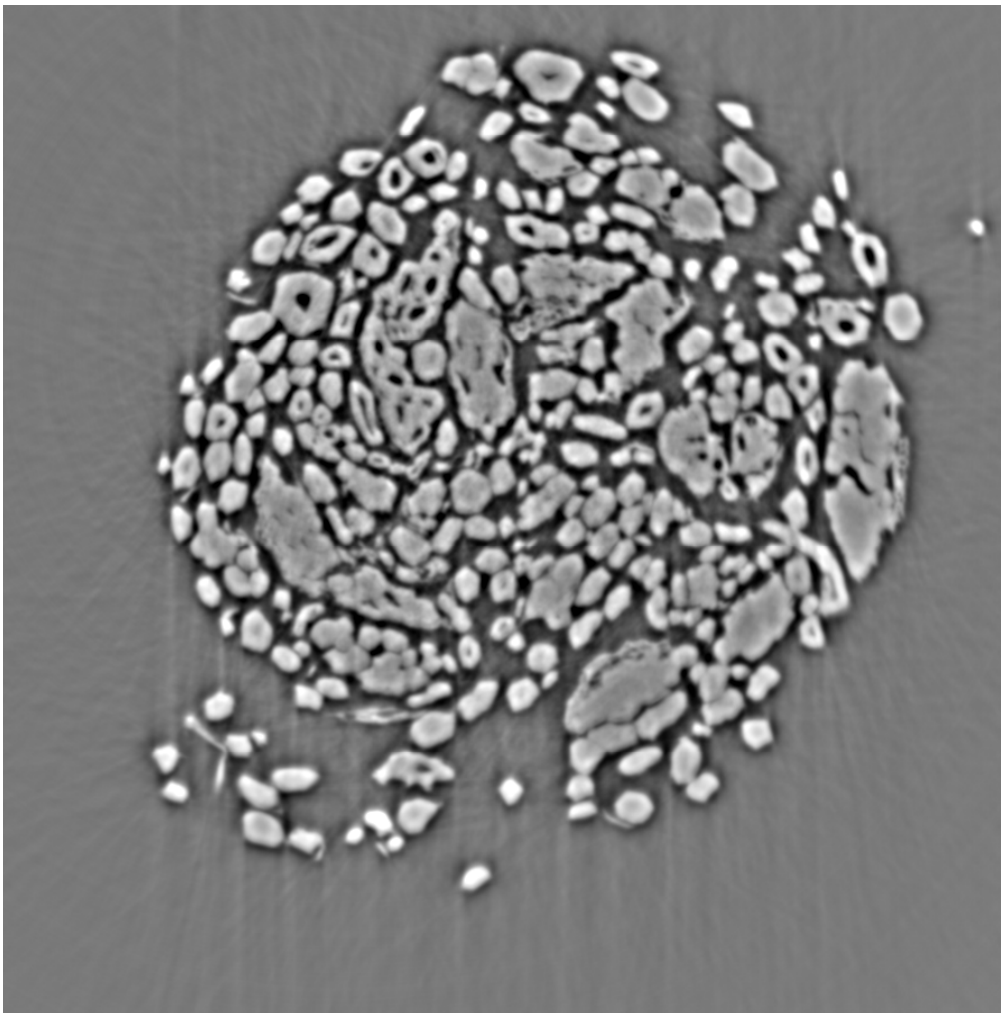

X-ray tomography:

- Limited twisting angle in center of yarn
- High twisting angle at outer boundary of yarn

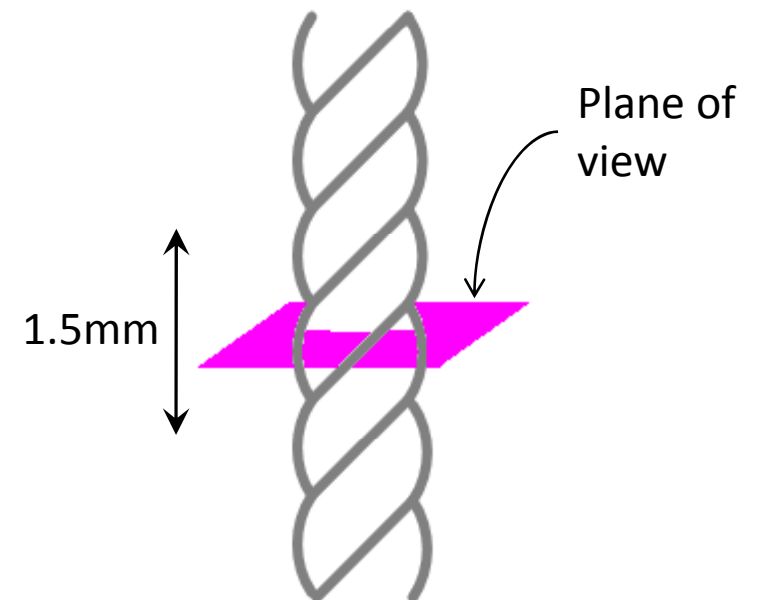

Source: Rask (2011), NATEX project

Fibre twisting in natural fibre yarns

Estimation of the mean fibre twisting angle in a ring spun yarn

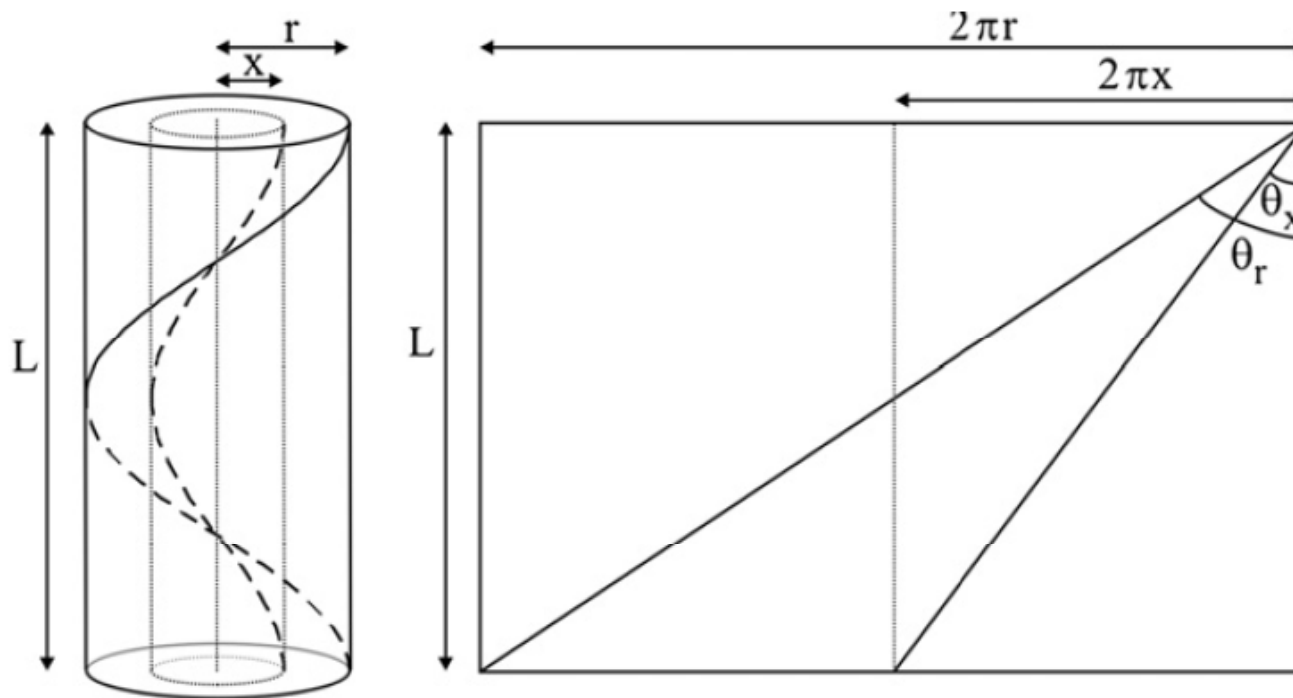
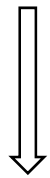

Fig. 7. Model of the twisted fibre structure in a ring spun yarn.

Fibre twisting in natural fibre yarns

Estimation of the mean fibre twisting angle in a ring spun yarn

$$\theta_{\text{mean}} = \int_0^r \frac{2 \pi x}{\pi r^2} \tan^{-1} \frac{2 \pi x}{L} dx$$



$$\theta_{\text{mean}} = \theta_r + \frac{\theta_r}{\tan^2 \theta_r} - \frac{1}{\tan \theta_r}$$

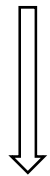

for $\theta_r < 40^\circ$

$$\theta_{\text{mean}} \approx 0.7 \theta_r$$

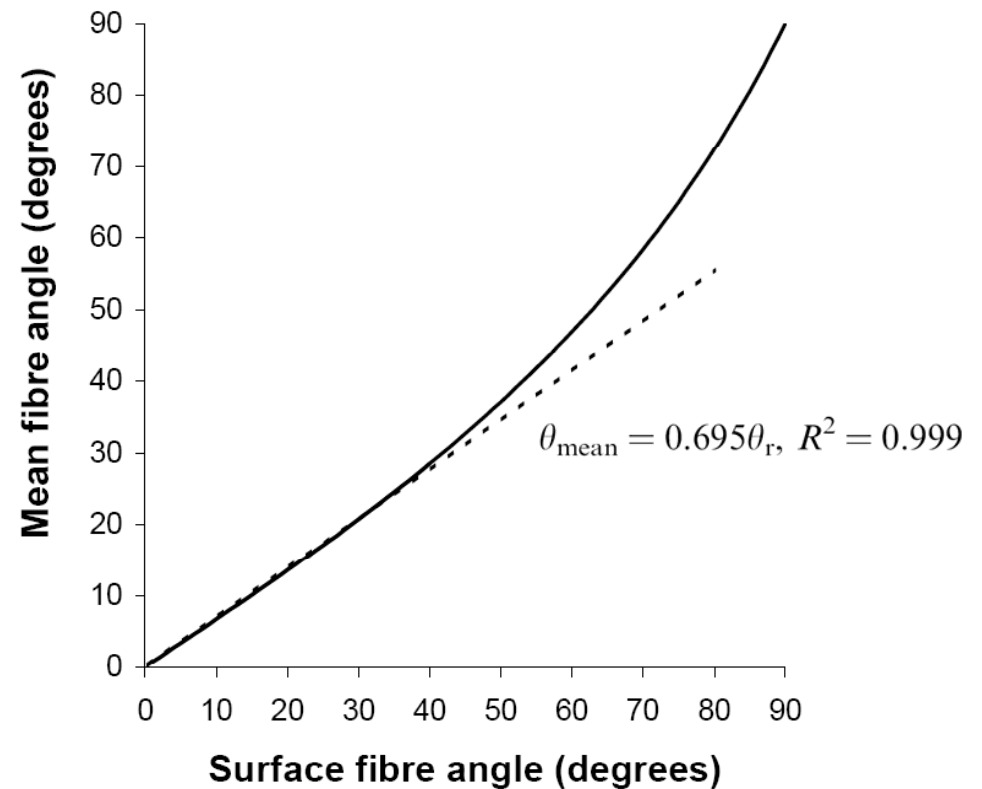

Fibre twisting in natural fibre yarns

Tool for calculating the fibre twisting angle

Correlating fibre twisting angles and production twisting number for a ring-spun yarn

November 2010

Morten Rask
 Material Research Division
 Risø National Laboratory for Sustainable Energy
 Technical University of Denmark
 Contact: mrank@risoe.dtu.dk

θ_s , Surface fibre twisting		θ_m , Mean fibre twisting*		L, length of single twist	Twisting number (turns/meter)
degrees	radians	degrees	radians	meter	1/meter
1	0.017	0.67	0.012	0.2160	4.6
2	0.035	1.33	0.023	0.1080	9.3
3	0.052	2.00	0.035	0.0719	13.9
4	0.070	2.67	0.047	0.0539	18.5
5	0.087	3.34	0.058	0.0431	23.2
6	0.105	4.01	0.070	0.0359	27.9
7	0.122	4.68	0.082	0.0307	32.6
8	0.140	5.35	0.093	0.0268	37.3
9	0.157	6.02	0.105	0.0238	42.0
10	0.175	6.69	0.117	0.0214	46.8
11	0.192	7.37	0.129	0.0194	51.6
12	0.209	8.05	0.140	0.0177	56.4
13	0.227	8.73	0.152	0.0163	61.2
14	0.244	9.41	0.164	0.0151	66.1
15	0.262	10.09	0.176	0.0141	71.1
16	0.279	10.78	0.188	0.0131	76.1
17	0.297	11.47	0.200	0.0123	81.1
18	0.314	12.16	0.212	0.0116	86.2
19	0.332	12.86	0.224	0.0109	91.3
20	0.349	13.55	0.237	0.0104	96.5
21	0.367	14.26	0.249	0.0098	101.8
22	0.384	14.96	0.261	0.0093	107.2

Input parameters here:

tex value (g/1000m)
100

ρ_f , fibre density (g/cm³)
1.55

V_f , volume percentage of fibres in yarn (%)
57.04

See sketches to the right for illustration of V_f

If the volume percentage of fibres in the yarn is unknown, it can be found from the yarn radius:

r, yarn radius (mm)
0.6

measured volume percentage of fibres in yarn (%)
57.04

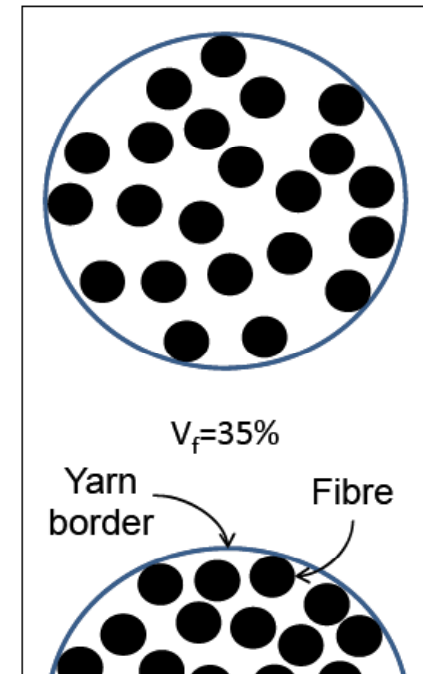

Fibre orientation in composites

Unidirectional fibres

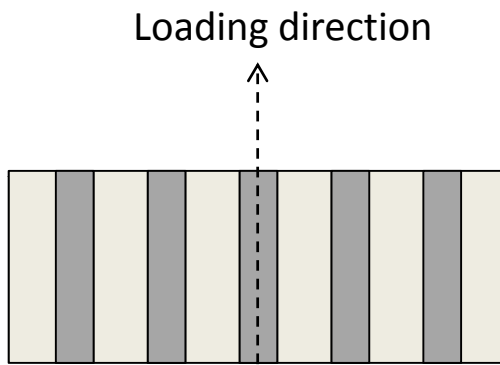

Rule-of-mixtures model

$$E_{c0} = V_f E_f + (1 - V_f) E_m$$

Stiffness of composites with different fibre types
($V_f = 0.50$ for all composites)

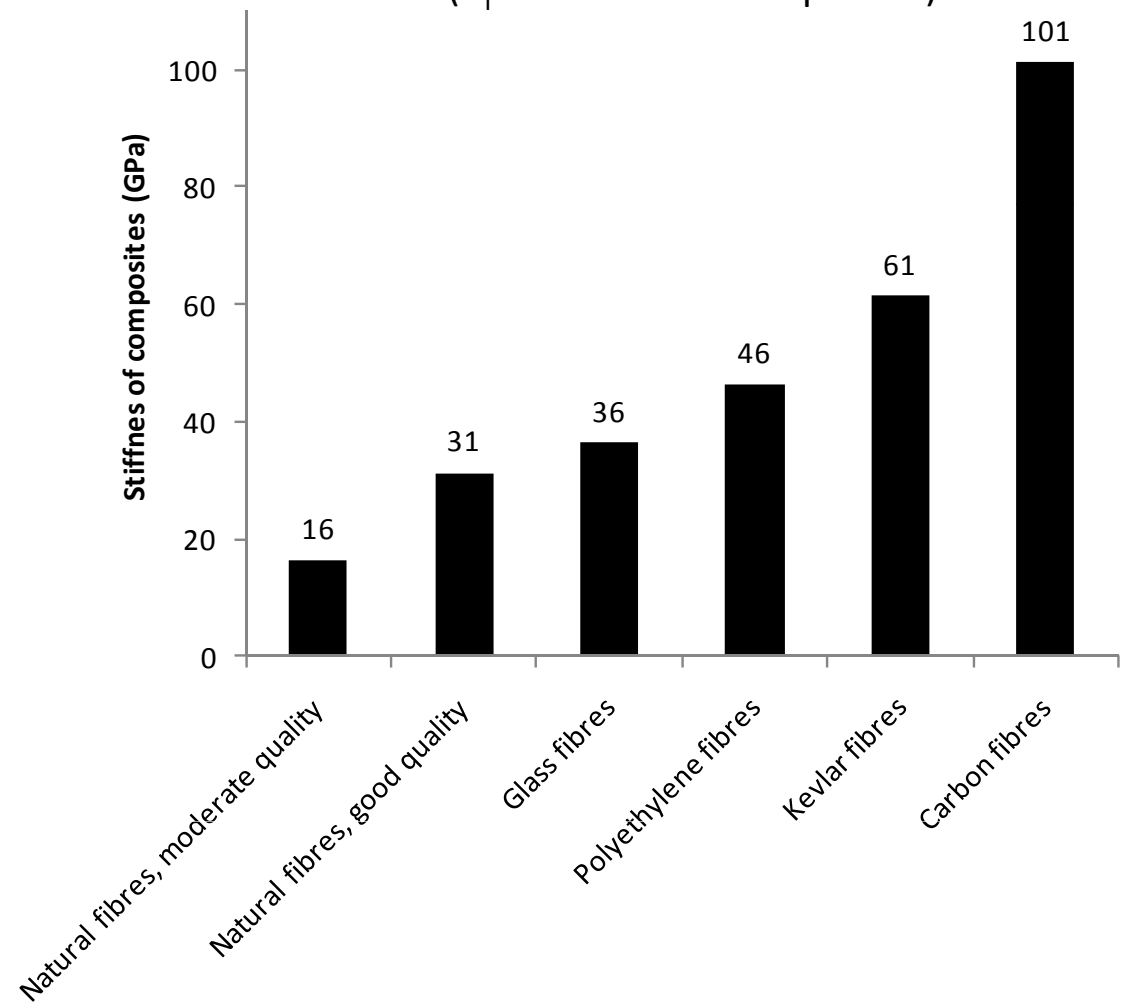

Fibre orientation in composites

Unidirectional fibres: off-axis angle

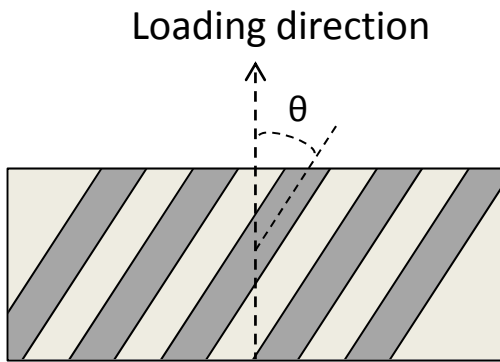

Plane stress model

$$\frac{1}{E_{c\theta}} = \frac{\cos^4 \theta}{E_{c1}} + \frac{\sin^4 \theta}{E_{c2}} + \sin^2 \theta \cos^2 \theta \left(\frac{1}{G_{c12}} - \frac{2\nu_{c12}}{E_{c1}} \right)$$

Composite stiffness vs. fibre off-axis angle

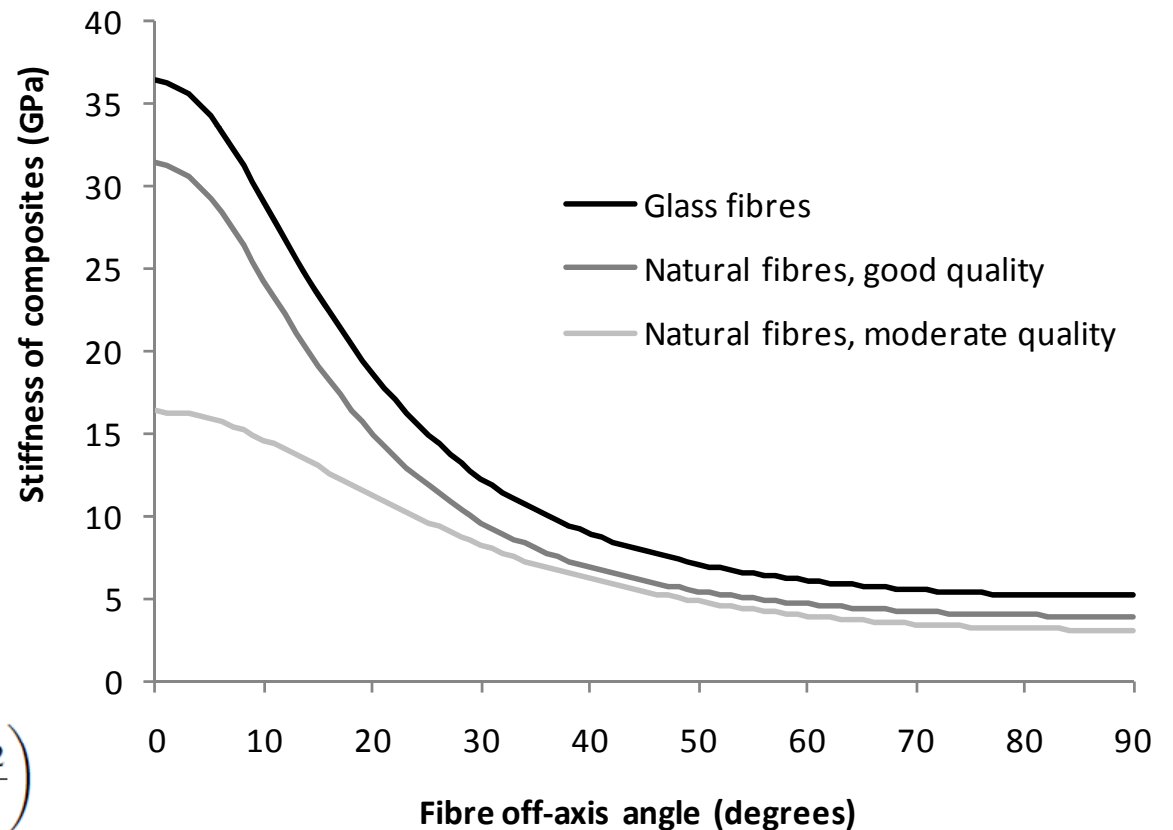

Unidirectional natural fibre yarn composites

– Effect of yarn off-axis angle

Hemp yarn/PET composites

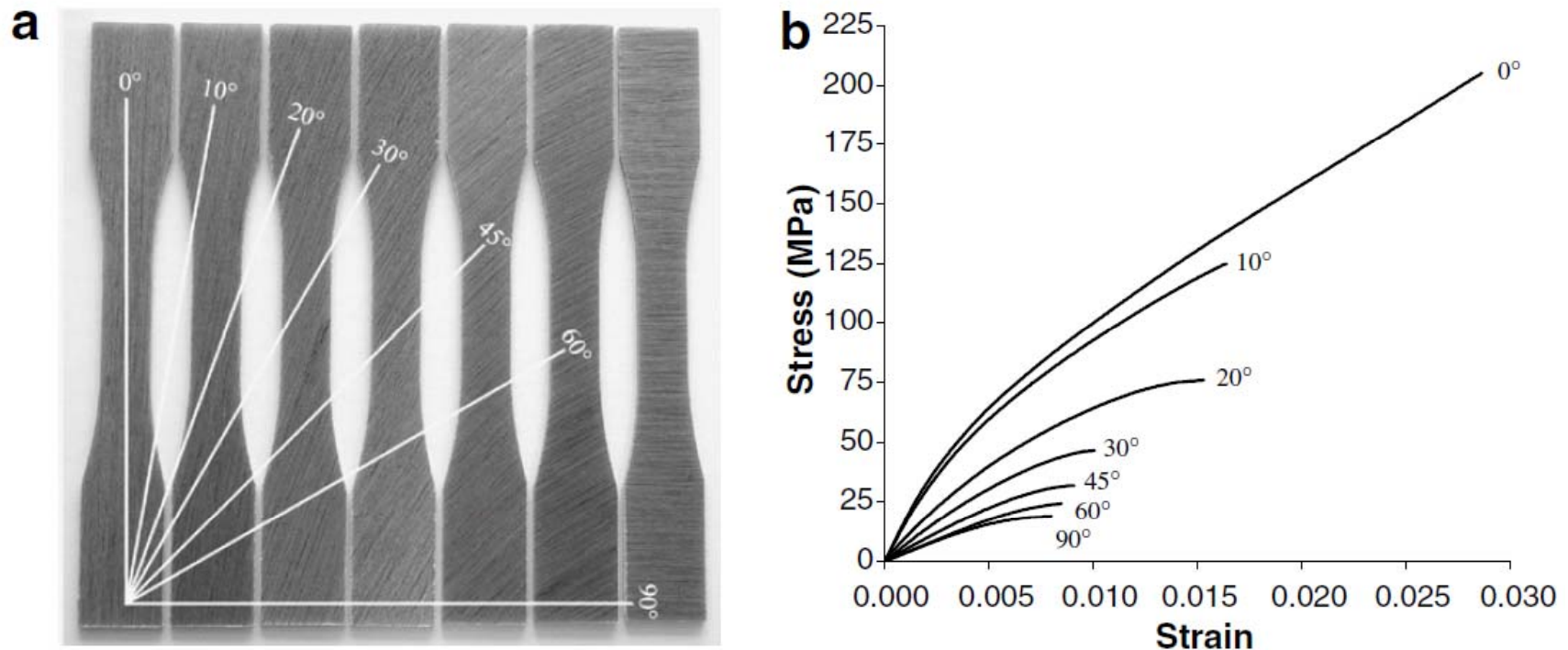

Fig. 8. (a) Shows examples of tensile specimens of He53/PET composites with the yarn axis inclined at various angles to the loading direction. (b) Shows the corresponding stress-strain curves.

Source: Madsen et al. (2007)

Unidirectional natural fibre yarn composites

– Effect of yarn off-axis angle

Hemp yarn/PET composites

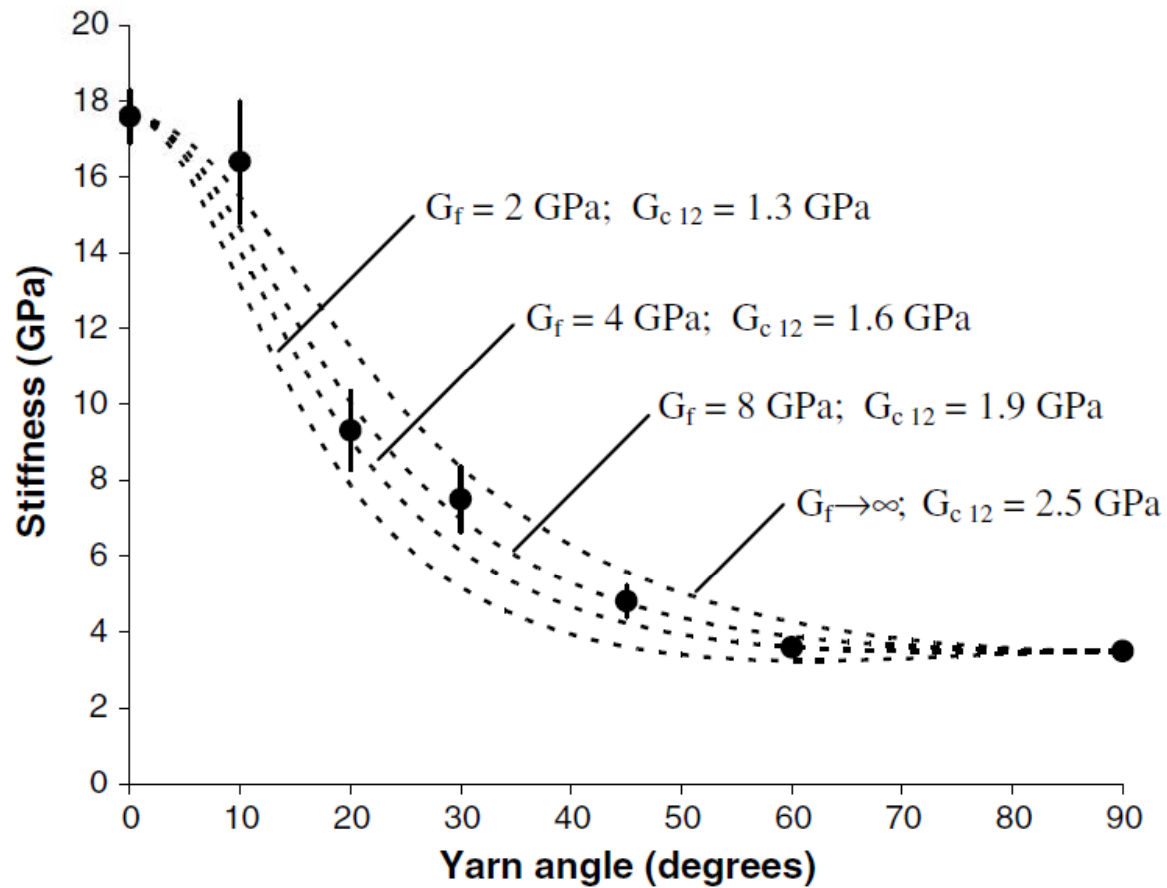

Source: Madsen et al. (2007)

Unidirectional natural fibre yarn composites – Effect of yarn off-axis angle

Flax yarn/PET composites

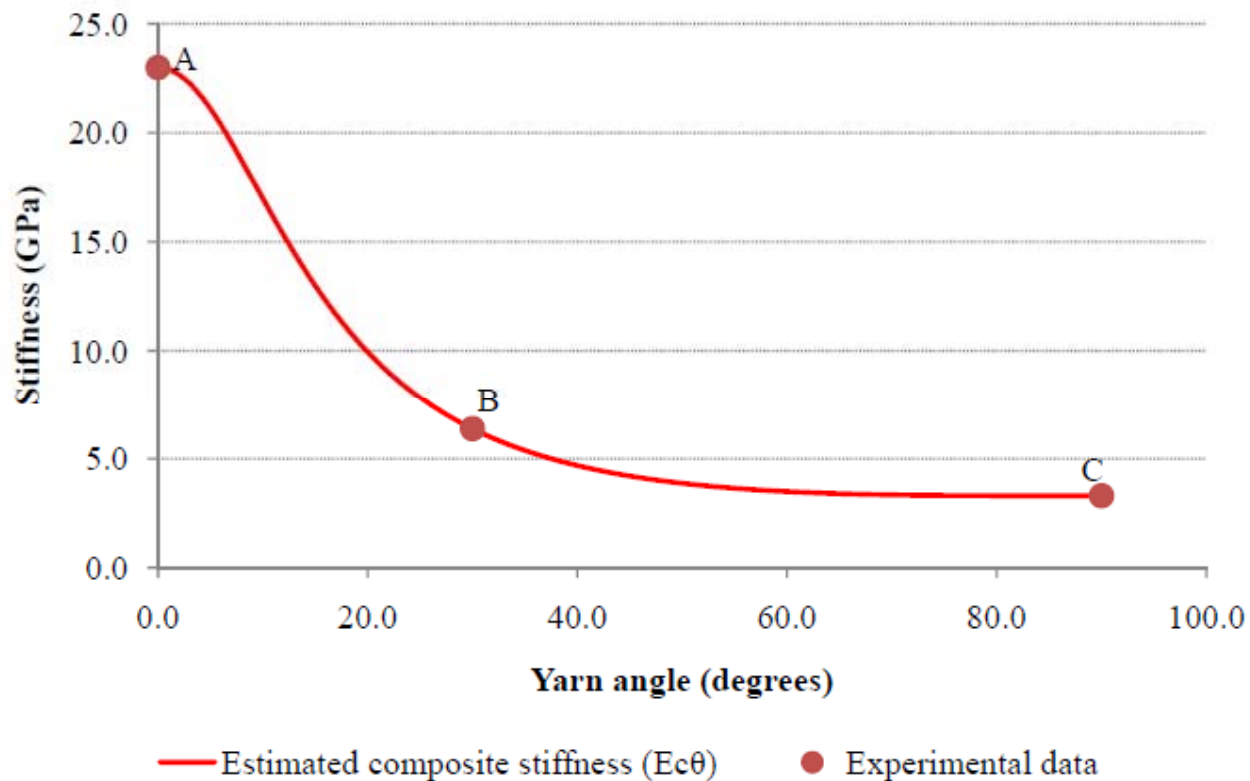
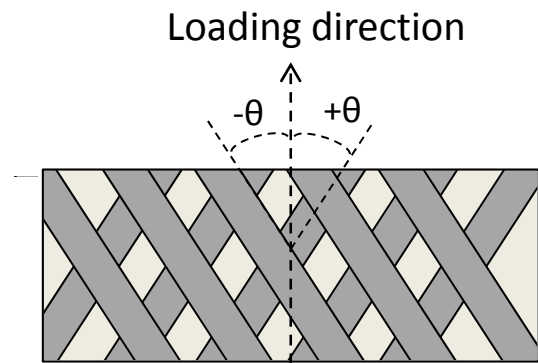

Figure 6.31 Stiffness as a function of yarn angle.

Fibre orientation in composites

Unidirectional fibres: \pm off-axis angle



Composites laminate theory

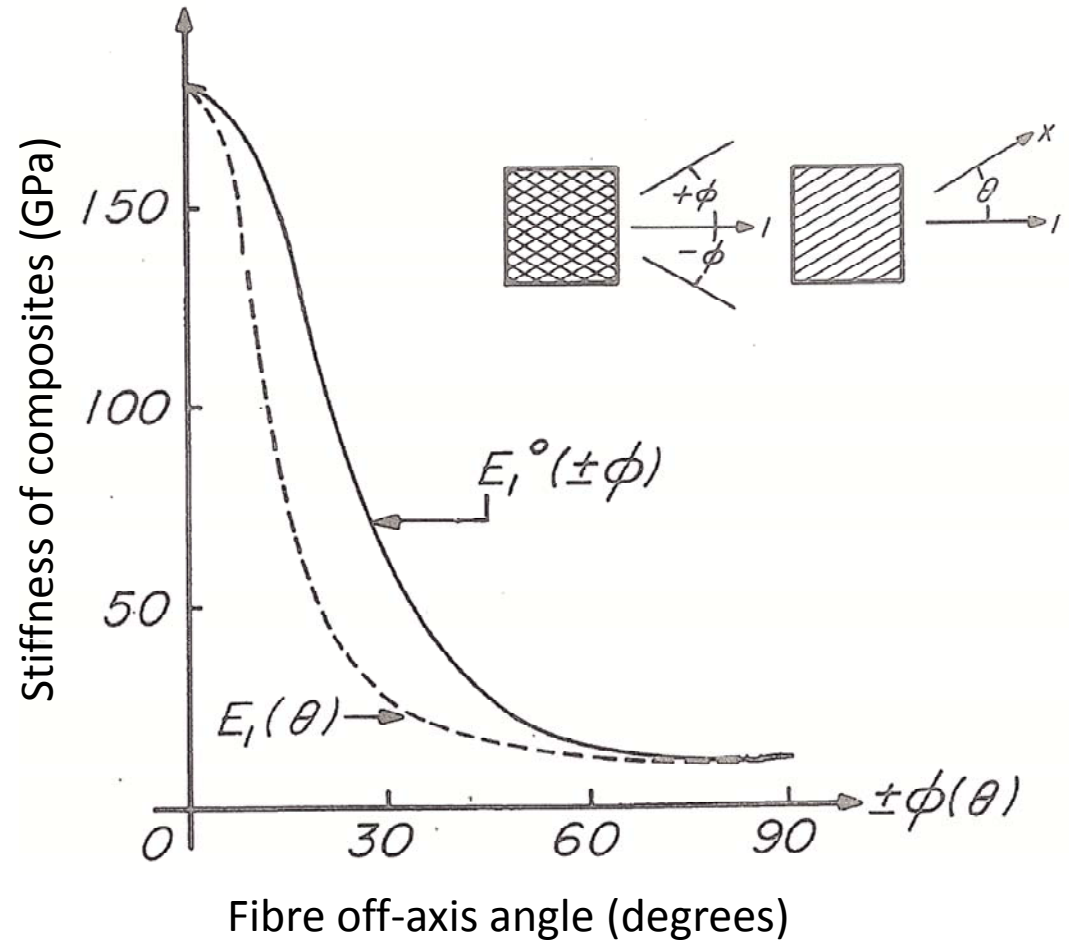

Source: Tsai and Hahn (1980)

Fibre orientation in composites

Twisted fibres

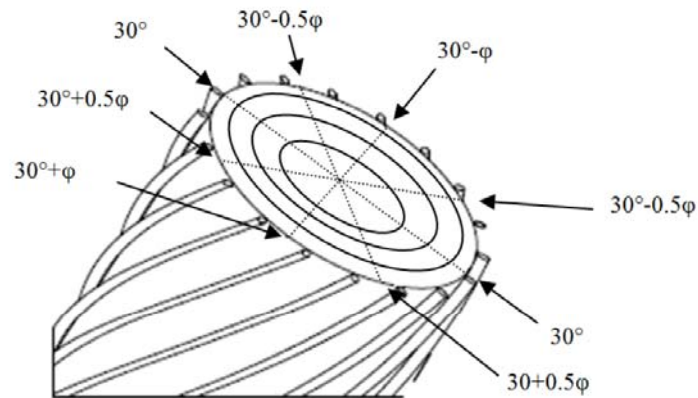

- Complex 3D fibre orientation
- No existing model available

Composite stiffness vs. fibre twisting angle

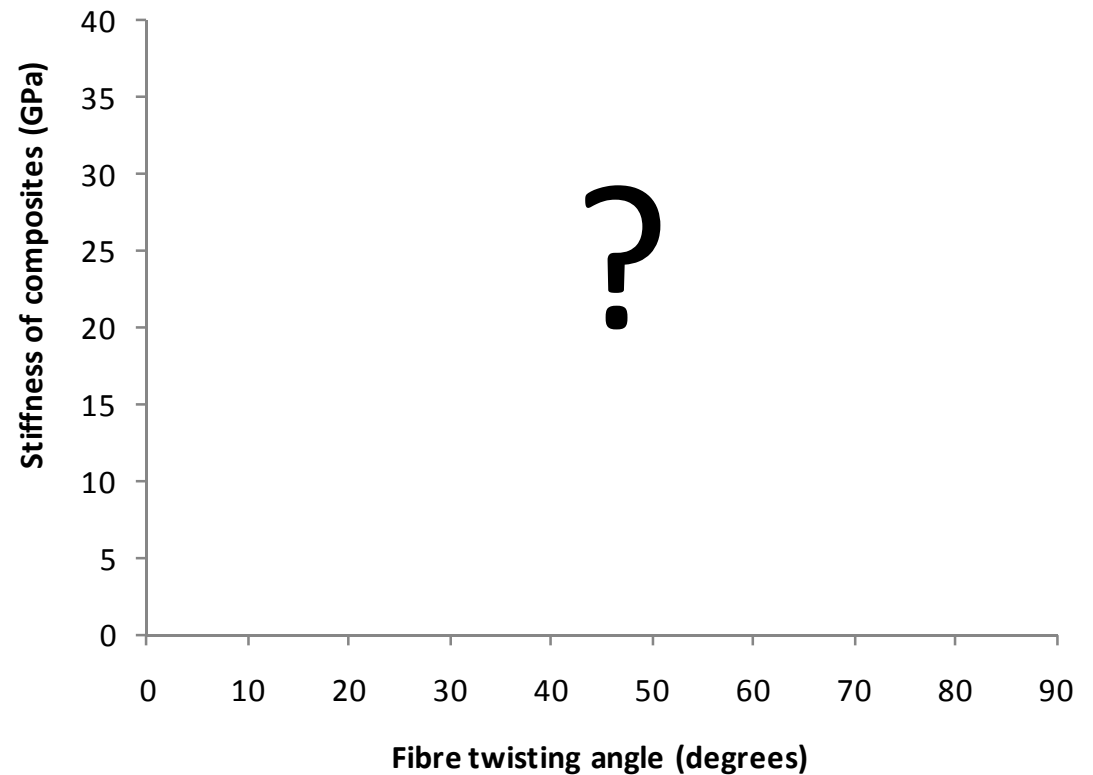

Unidirectional natural fibre yarn composites

– Effect of fibre twisting angle

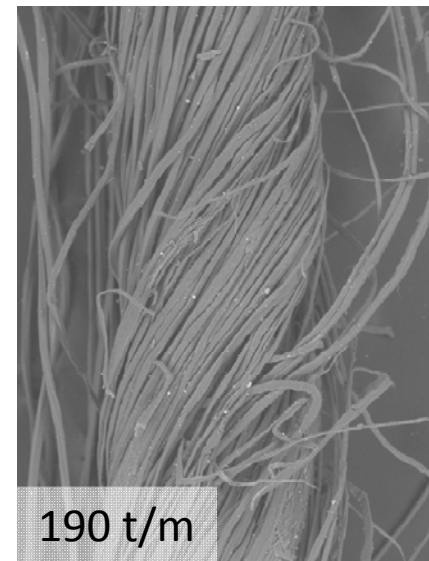
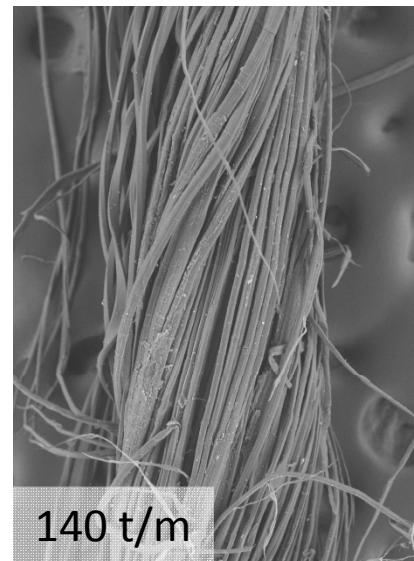
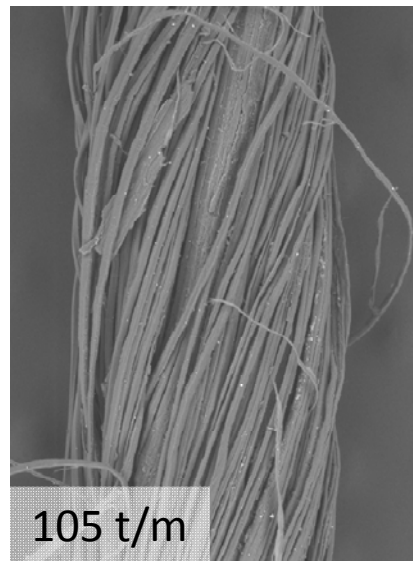
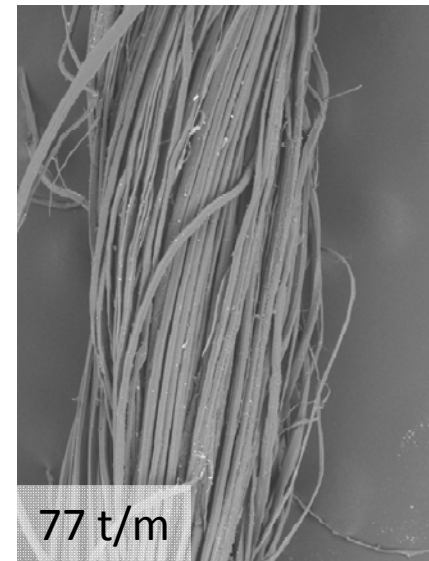
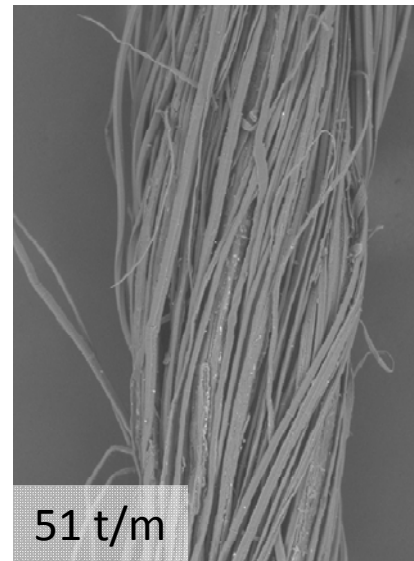
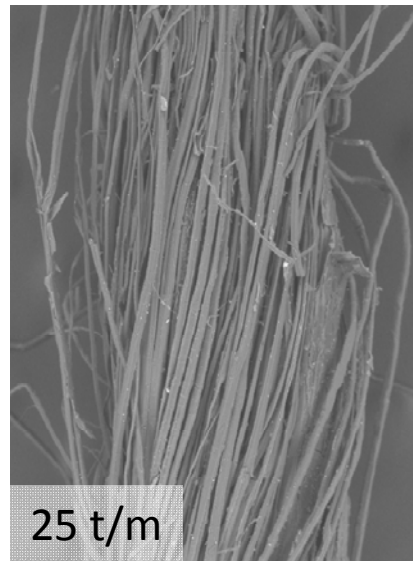
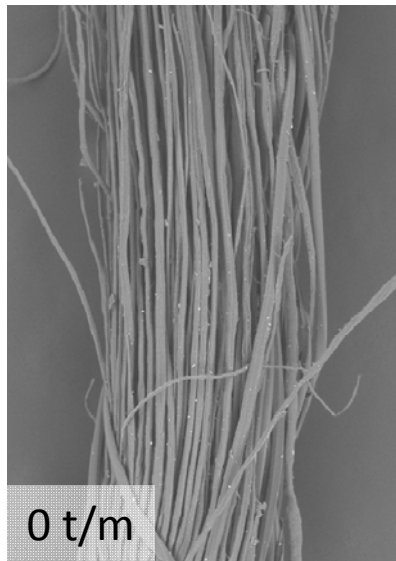

L x180 500 um
2011-03-15

Source: Rask (2011),
NATEX project

Unidirectional natural fibre yarn composites

– Effect of fibre twisting angle

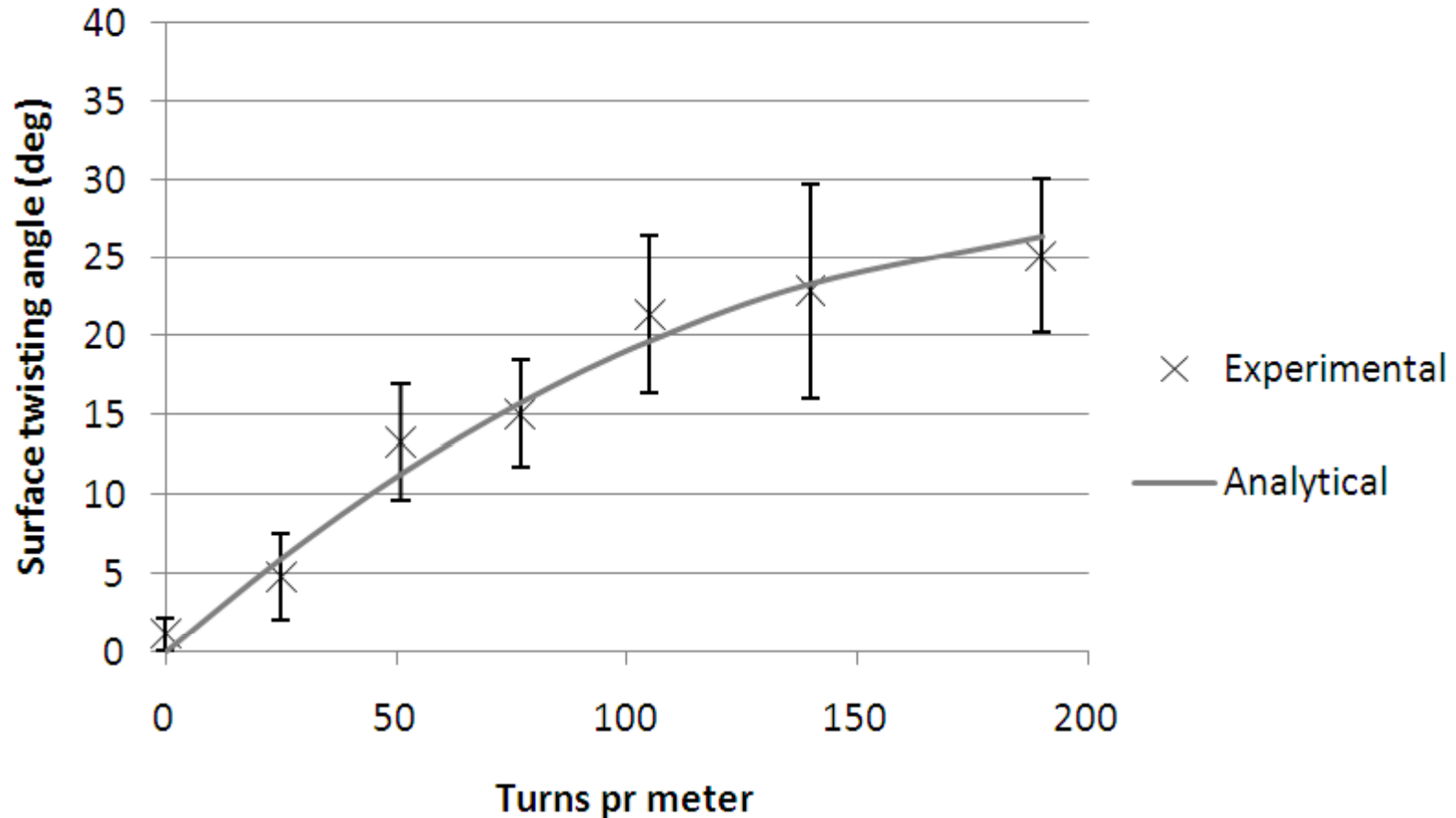

Source: Rask (2011), NATEX project

Unidirectional natural fibre yarn composites

– Effect of fibre twisting angle

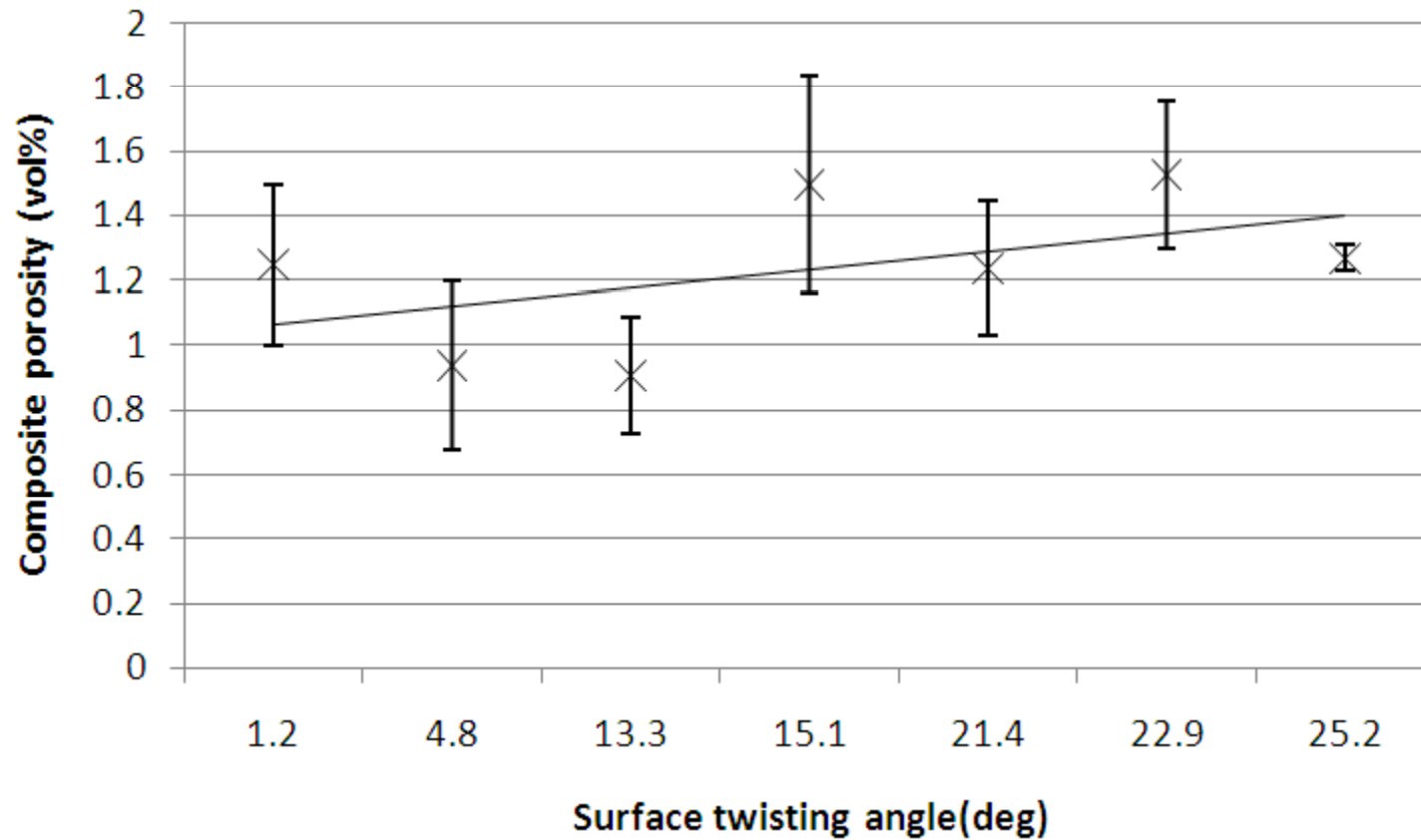

Source: Rask (2011), NATEX project

Unidirectional natural fibre yarn composites

– Effect of fibre twisting angle

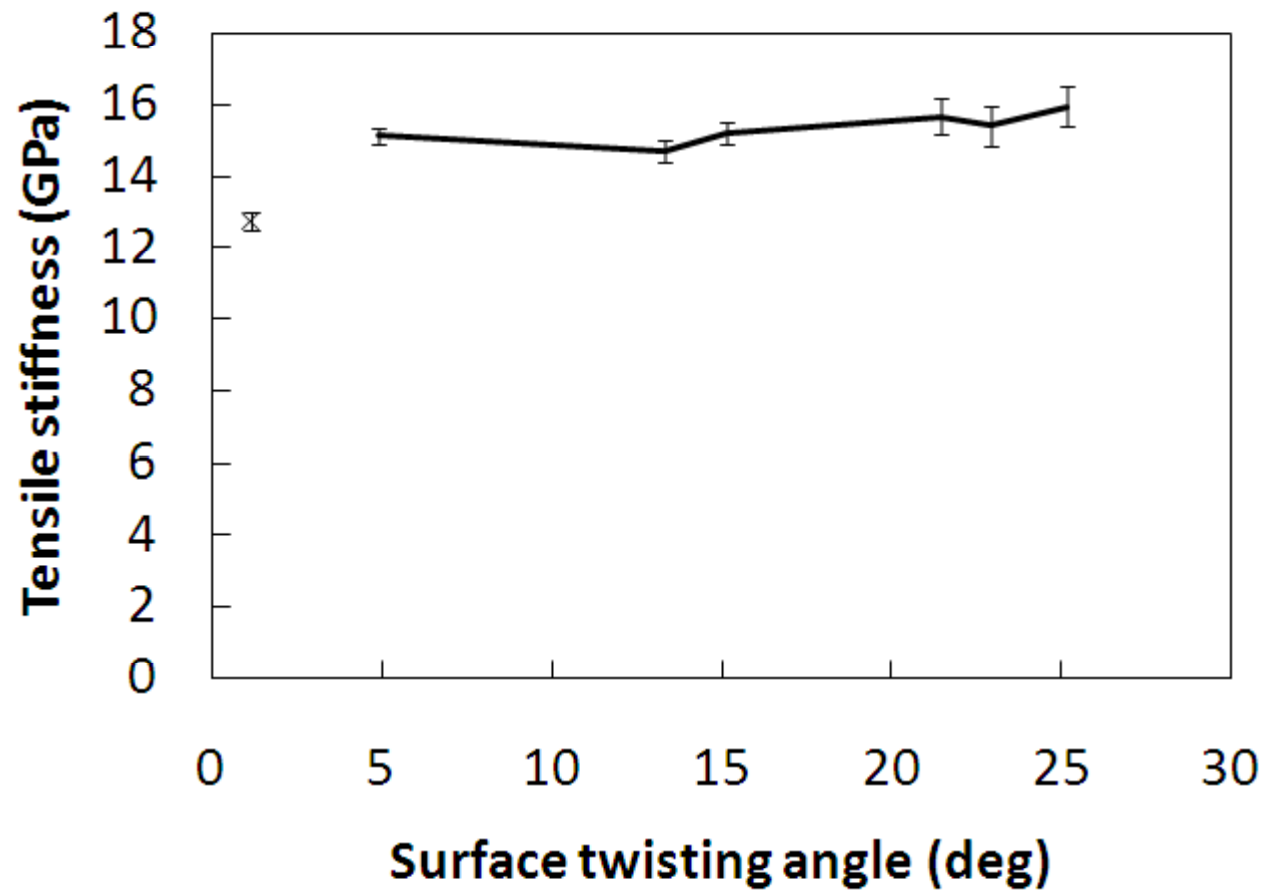

Source: Rask (2011), NATEX project

Conclusion

- Work on fibre twisting is ongoing
- We need models relating fibre twisting to composite performance
- We will make further experimental studies and also use a FEM approach

References

Madsen B et. al. (2008). “Hemp yarn reinforced composites – I. Yarn characteristics”. Composites Part A 38 2194-2203.

Pegoraro L (2010) “Investigations of the influence from the manufacturing process and the resulting microstructures on mechanical properties of biocomposites”, Master thesis project.

Rask M (2012) “Microstructure and fracture mechanical properties of aligned natural fiber composites”. Ongoing ph.d. project.

Tsai SW and Hahn HT (1980). “Introduction to composite materials”. Technomic Publishing, Westport, USA. p. 142.