

Technical University of Denmark



## Electronics Department. Semi-annual report for the period 1 October 1970 - 31 March 1971

Forskningscenter Risø, Roskilde

*Publication date:*  
1971

*Document Version*  
Publisher's PDF, also known as Version of record

[Link back to DTU Orbit](#)

*Citation (APA):*  
Research Establishment Risø, R. (1971). Electronics Department. Semi-annual report for the period 1 October 1970 - 31 March 1971. (Risø-M; No. 1430).

## DTU Library

Technical Information Center of Denmark

---

### General rights

Copyright and moral rights for the publications made accessible in the public portal are retained by the authors and/or other copyright owners and it is a condition of accessing publications that users recognise and abide by the legal requirements associated with these rights.

- Users may download and print one copy of any publication from the public portal for the purpose of private study or research.
- You may not further distribute the material or use it for any profit-making activity or commercial gain
- You may freely distribute the URL identifying the publication in the public portal

If you believe that this document breaches copyright please contact us providing details, and we will remove access to the work immediately and investigate your claim.

Danish Atomic Energy Commission  
Research Establishment Risö

# ELECTRONICS DEPARTMENT

SEMI-ANNUAL REPORT FOR THE PERIOD  
1 OCTOBER 1970 - 31 MARCH 1971

October 1971

R-8-71

Risø - M - 1430	Title and author(s)  <p style="text-align: center;">Semi-annual Report for the Period 1 October 1970 - 31 March 1971</p>	Date October 1971
		Department or group Electronics Department
		Group's own registration number(s)  R-8-71
28 pages + tables + 10 illustrations		
Risø - M - 1430	Abstract <p>The report reviews the activities of the department in the fields: instrumentation for Risø experiments, measuring methods, automation. Topics treated in special chapters are: aneroid barometer, EDP in future Risø instrumentations, nuclear geophysical methods, EDP system for a power station, optimization of system models, verbal records from troubleshooting jobs. Publications and lectures by staff members are listed.</p>	Copies to
		Abstract to
Fi 25-204	Available on request from the Library of the Danish Atomic Energy Commission (Atomenergikommissionens Bibliotek), Risø, Roskilde, Denmark. Telephone: (03) 35 51 01, ext. 334, telex: 5072.	

CONTENTS

	Page
<b>Systems Techniques</b> .....	2
<b>The Process Control System for the SEAS Power Station 2 at Stignæs</b> .....	3
<b>Optimization</b> .....	6
<b>Analysis of Trouble Shooting Records</b> .....	8
<b>DR 2 Reactor Computer System</b> .....	9
<b>Nuclear Geophysical Methods</b> .....	11
<b>Research Instrumentation</b> .....	15
<b>Digital Read-out for Aneroid Barometer</b> .....	17
<b>Water Film Measurements</b> .....	20
<b>Electronic Data Processing Facilities</b> .....	22
<b>Process Control</b> .....	25
<b>Miscellaneous</b> .....	25
<b>Lectures, Publications, Meetings etc.</b> .....	27

## SYSTEMS TECHNIQUES

The following themes are covered: control, man - machine relations, system structures, reliability and safety, minicomputers.

Three years of co-operation with SEAS ended during the period. The software system resulting from this work is described in a later chapter.

Different methods for the optimization of system models have been studied on the hybrid computer installation. The work on self-organizing control is now done in collaboration with Servolaboratoriet, as a Ph. D. study.

Man - machine work was concentrated in three areas. A recording system for the collection of data on alarms and response times at the DR 3 reactor has been developed and is now ready for use. In the work on mental models, several tape recordings have been thoroughly analysed, and an account of the results is given below. A study of the job of the reactor operator at DR 2 ( task analysis ) was initiated. This theme may be viewed in the light of the former work on mental models from which results might suggest rather large differences between the real way of doing the job and the procedures assumed by designers to be effective.

A classification of control tasks has been worked out as part of the study of structures in control systems (1). Applying this classification, an analysis has been started on the instrumentation of an oil-fired power plant.

The cause/consequence method is a tool for analysing possible evolutions of accidents in complex systems (1). Investigations have been started on the applicability of this method to quantitative probability analysis. Work on the English computer program for reliability calculations - NOTED - continues. Various obscure points have been illuminated by test runs.

Nearly a dozen minicomputers are now used in experimental installations at Risø. To assist the development of the necessary software, the department has a programming facility with extra back-up storage. The installation has been extended with a fast line printer, and system software was supplemented with the CORR program for correction of ASCII files.

## THE PROCESS CONTROL SYSTEM FOR THE SEAS POWER STATION 2 AT STIGSNÆS

This section gives a short description of the EDP program developed for the Power Station 2 at Stigsnæs. More detailed descriptions are given in (7) and (8), and a brief description of the program structure may be found in (2).

The program system has 4 main parts:

- A. Monitorprogram ORG 1 from Siemens.  
The monitor performs input/output functions, administration of the multiprogram system ( maximum 24 programs ), interrupt identification on the higher level, and finally administration of cyclic functions.
- B. The operative system.  
This part controls loading of relocable programs from the backing store and program start in a section of about one third of the core memory. These programs may be either process programs or off-line programs such as editor or assembler. Some common routines for the process programs are also included in the operative system e. g. : Input-output routines for typewriter queues, format conversion routines, and the main communication routines for operators ( typewriter and pushbutton inputs ).
- C. The main process supervisor.  
The process supervisor consists of 3 parts: A spontaneously activated alarm routine giving alarm logs on a typewriter. A fast cyclic main program controlling loading and running of fast but small subprograms with periods of 1 to 10 seconds. A slower cyclic main program controlling most of the process supervisor subprograms with a fixed period of 10 seconds. The two cyclic programs share the same program core buffer of 2240 words and the subprograms are loaded in dataformat ( contrary to relocable format ).
- D. Relocable process programs.  
Process programs available on request are all relocable and have to be loaded from the backing store by the operative system. The operator calls the programs from pushbuttons or typewriter. Typical programs are log, display and plotter programs. The main process supervisor performs the following tasks:

1. With a 2 second period:
  - A. Scanning of approximately 144 digital signals with detection of state changes in the plant for logging on a typewriter.
  - B. Conversion and filtering of about 10 analog signals for which digital filtering is necessary for further use at a lower speed.
  - C. Updating of data for a digital display showing a single analog signal on operator's demand.
2. With a 10 second period:
  - A. Conversion and limit value checks of 192 tube wall temperatures. Two fixed upper limits are used for each temperature. Temperature gradients are calculated and checked against a maximum value for groups of tubes, and group mean values are stored for display purposes. About 900 tube temperatures may be fed to the computer via easily changeable connectors. It is possible to measure all 900 temperatures by means of an assisting program and store them in the backing store within 15 minutes. A plotter program is used to plot temperature profiles for the different tube sections, and a log program tabulates the temperatures on a typewriter.
  - B. Conversion of all other analog signals (about 200) combined with validity checks for some of the transducers.
  - C. Limit value checks of main temperatures and pressures for water, steam, air and combustion gas with load dependent limit values.
  - D. Calculation of heat and mass balances for the boiler and analysis of fault situations. An unbalance of about 5% of full load values may be detected, and distinctions can be made between deviations caused by either load changes or boiler malfunctions.
  - E. Supervision of separate plant sections. For the economizer the following quantities are checked:  
Temperature increase from inlet to outlet, outlet temperature against saturation temperature, and outlet flow against inlet flow.

For the air preheaters: Calculation and check of temperature balance for air and combustion gas in order to detect slowly developing layers of dirt and catastrophic faults as e. g. fire.

For the air blowers: Calculation of the working point in a pressure-flow diagram.

For the electrical generator and the feed water pump motors: Limit checks of coil temperatures.

For the high pressure steam: Calculation of the working point in a temperature - temperature rate diagram and automatic trip of the turbine in case of too rapid temperature drop over too large a range.

- F. Storage of trend curves for main temperatures and pressures at the backing store ready to be used for display and plotter programs.

The plant operators are able to call programs for log, display and plotting functions by means of pushbuttons. water and steam tube temperatures are logged by a special program in groups of 16. Other plant variables are logged by a standard log program in groups, e. g. temperature and pressure for the air and oil supply. Single variables can be displayed on a digital display and updated every 2 seconds. Trend displays of main variables, temperature profiles, and tables with digital values for groups of variables can be shown on a storage display without updating. Temperature profiles and trend curves can in addition be plotted on a X-Y plotter.

Programs for changes of parameters and for communication with the process programs can be called and operated from the EDP operator's typewriter.

The program system is still under development and more tasks are added, e. g. calculations of stress in thick steel walls, to the supervisor program. Later it is intended to let the computer interfere in the plant on the basis of the supervisor programs and to develop start - stop functions.

## OPTIMIZATION

The "accelerated random search" (10) and the "pattern search" (9) strategies have been studied with a view to optimization of system models on computers. These methods are simple with respect to memory requirements but relatively effective in terms of computation time. The pattern search method has been investigated in connection with a student work (11).

The strategies given are selected on the basis of the literature. The methods are evaluated by using the PDP8 computer for the minimization of two algebraic expressions: A sum of squares, and Rosenbrock's function (banana shaped valley). A pattern search program was used in the hybrid computer for automatic P-I controller adjustment for optimization of the step response of a system model.

Fig. 1 gives a comparison of the methods. Since most of the computation time is used for function evaluations, the number of these is used as a measure of the effectiveness of the method. It is interesting to note that the number of evaluations is proportional to the number of parameters in the algebraic expression for the given conditions. The number of function evaluations is practically equal for the two methods in the given case, but the accuracy is much higher for the pattern search than for the random search method. The results depend on the step lengths, reduction factor and acceleration factors selected, but the tendency shown is typical.

The pattern search method can hang up on sharp valleys or "false minima" in the function value/parameter space. However, no multiple minima were stated in the cases studied. No hang-up problems were observed when small step lengths were allowed in the pattern search program. One disadvantage of the random method is that a test of the method is very time consuming. 20 to 50 runs had to be carried out for the measurement of one mean function evaluation number.

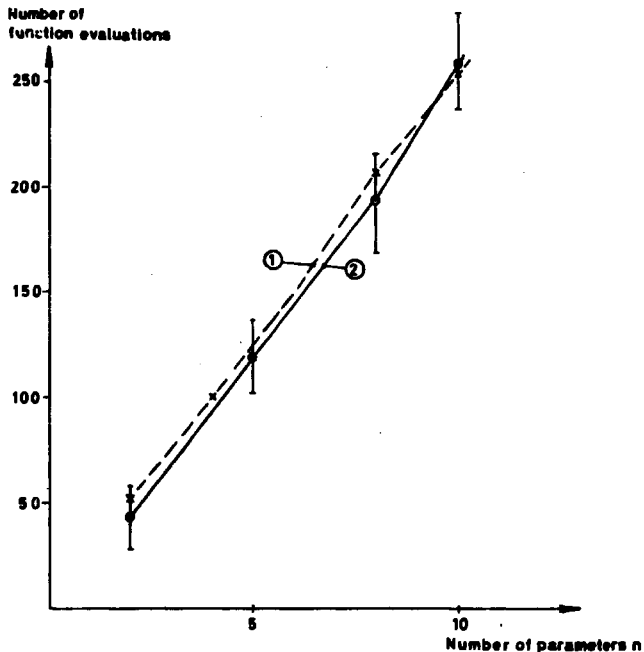

Figure 1. Minimization of  $E = \sum_{i=1}^{i=n} x_i^2$ . Start values  $x_1; x_2 \dots x_n = 1; \dots 1$

(1) Pattern search (De Graag version I).  $E_{\min} \approx 4 \cdot 10^{-12}$

Start step length 0.1, step reduction factor 0.5.

(2) Accelerated random search.  $E_{\min} \approx 2 \cdot 10^{-4}$

Mean function evaluation number, 20 runs per point.

Step length spread  $\sigma = 0.1$ , acceleration factor = 2.

## ANALYSIS OF TROUBLE SHOOTING RECORDS

Some forty records taken by technicians verbalizing their procedures during trouble shooting in electronic instruments and systems have been analysed. The work is part of a program to study the behaviour of man as an information receiver in diagnostic tasks. We have found a better understanding of this aspect of man important, it is necessary in the design of display systems to support process control operators under abnormal plant conditions. It is necessary too in the layout of systems and manuals to support maintenance and repair staff. We have also found it important to perform experiments under real working conditions to be able to use the results published from more clear-cut psychological laboratory experiments.

Electronic trouble shooting under real-life conditions is a multiple task. On a time-sharing basis the technician will formulate his route for search through the system by use of diagrams or functional reasoning, he will locate the route in the real system, manipulate measuring devices, establish norms for his judgements from diagrams, experience and functional reasoning, and plan his activities and keep track in this plan. We found as one of the results from the real life approach that the mental load from difficulties in one of the secondary tasks has significant bearing upon the main procedure. Great caution should be exercised in generalizing from laboratory experiments with specially designed equipment where the task is stripped from all secondary activities.

Furthermore, our experiments indicate that certain aspects of activities and procedures found unsystematic or erratic in behaviouristic studies which take the rational man as a norm for judgement of the performance, may prove to be systematic and efficient in the light of the man's comments. What is efficient all depends upon the goal of the man involved. In such trouble shooting studies and also in textbooks used for education of trouble shooters the rational man is often expected to make use of all available information: Few measurements followed by rational deduction. But the goal of the man in real-life is not to minimize the number of necessary decisions. If he is supposed to minimize the time spent, a rapid sequence of simple decisions and use of redundant measurements may be found more efficient than careful reasoning.

Our study also indicates that although the overall goal of the man most likely would be to minimize the time spent in the task, a goal that is important in the control of the detailed procedure is to minimize the information flow and the load of short term memory to permit simultaneous handling of the



different tasks, and thus the secondary tasks are important aspects of the working conditions.

A trouble shooter in field work is faced with an instrument which he usually expects to have been working properly. Sometimes he may consider his task as a search to find where the faulty component is located and not primarily to explain why the system has the observed faulty response. If standards are available ( e. g. data from manuals ) from which he can judge measured data individually, he may succeed by a purely topographic search without considering any functional relation between data.

The records from our experiments show a preference on the part of the technicians to compose procedures as sets of rapid sequences, resulting in a stepwise limitation of the necessary field of interest, topographically speaking. Furthermore, they show a very marked ability of the technicians to find search sequences which can be based upon a stream of simple good/bad judgements of the individual data.

Considering the data input capacity and the capacity of short-term memory needed by these procedures, they seem to be very efficient, but the information available to the subjects is not used efficiently, seen from a rational point of view.

We have now completed the analyses of the records and are preparing the reports. The next phase in the program is the implementation of the results for the improvement of the layout of electronic instruments and service manuals and the planning of similar experiments in industrial control room environments.

### DR 2 REACTOR COMPUTER SYSTEM

During the past six months, the double-computer configuration previously described (12) has been put into operation. In this way, both PDP8's have access to a common drum store. One of the computers, using the drum for program storage, collects raw data from the DR 2 once a second. It performs scaling and alarm checking and writes a new set of process data on the drum. The second computer, which has a separate disc for program and CRT picture storage, controls the display console and uses the drum as the main source of process data. Short messages between the two computers are exchanged via two separate 12-bit registers and are independent of the drum.

Results of the programming to date have shown that 4 k of core store is not sufficient to maintain a double CRT display. As a result, the system is currently limited to one CRT while an external 4 k buffer memory unit

is under construction.

In addition to the display formats included for the process operator two representations of computer system operation can be displayed. They are shown in fig. 2. The Y axis represents the cumulative time that each task requires of the PDP8 processor and the disc store respectively. These are useful as a check of system performance.

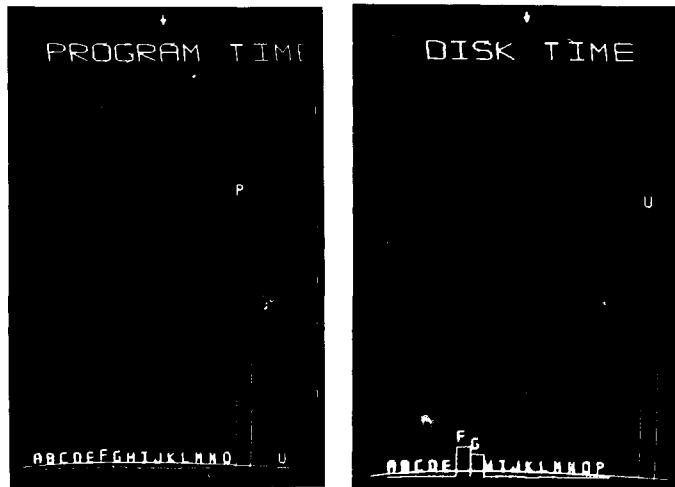

Figure 2.

## NUCLEAR GEOPHYSICAL METHODS

### Uranium and Thorium

The performance characteristics of the core-scanning system were evaluated based on various experiments. A comparison between results obtained by core scanning and ordinary core assaying showed that continuous scanning of one metre long core sections is accurate to within two percent. The step-response function of the system was found to match a cumulative normal distribution with  $\sigma = 3.75$  cm. Knowing the step-response function, we were able to unfold radioelement distributions measured by step scanning.

Continuous scanning and step scanning have been extensively used for studying the models of occurrence of uranium and thorium in lujavrites belonging to the southern part of the Ilímaussaq intrusion. Scanning of cores from the Ivigtut area was carried out for the Institute of Mineralogy, DTH. Scanning data from previous measurements of Kvanefjeld drill cores were utilized to obtain a calibration of our portable gamma-ray logger. There was good agreement between the calculated calibration constants and those given by the manufacturer on the basis of calibration measurements in model drill-holes at the USAEC's Grand Junction Office.

A new, automatic gamma-ray spectrometer has been constructed in co-operation with the workshop of the department. Fig. 3 shows a photograph of the instrument taken before the final assembly. From a magazine on the right side of the transport wheel, crushed rock samples in cylindrical plastic containers are successively fed to the spectrometer. The gamma-ray detector is a 6-inch diameter by 4-inch thick NaI (Tl)- crystal optically coupled to a 5-inch diameter photomultiplier. Twelve centimetres of a 84% lead alloy surrounds the crystal on all sides to suppress background radiation. The spectrometer is going to operate in conjunction with three single-channel analysers and three scalars. Read-out will be made on a teletype printer to permit data reduction on Risø's B 8500 Computer.

In co-operation with the Reactor Physics and the Service Departments we have started design work on a versatile calibration facility for radiometric prospecting instruments. The facility will comprise four 3-m diameter by 0.5-m thick concrete slabs of which three are going to have contents of uranium, thorium or potassium. The fourth slab will serve as a background reference locality.

Together with personnel at reactor DR 2 we are considering the possibilities of using this reactor for the determination of uranium and thorium in

rocks by delayed-neutron counting. The proposed measuring system will be based on a new pneumatic transfer tube giving access to a location at the edge of the reactor core. A lead cell for remote handling of the irradiated samples will be required.

The fission-track method was used to examine the distribution and abundances of U and Th in minerals of the Ilímaussaq intrusion. Uranium in steenstrupine, the most widely found radioactive mineral of the Kvanefjeld area, ranges from 0.03 to 1.6%, with an arithmetic mean of 0.6%; thorium ranges from 0 to 8.5%, with a mean of 2.3%. Pigmentary material associated with arfvedsonite in medium-to-coarse grained lujavrite of Kvanefjeld contains U in abundances up to 2.5%, but little or no Th. This may account for the comparatively low whole rock Th/U ratios measured by  $\gamma$ -spectrometry in this rock type. Eudialyte, the most common radioactive mineral in the bulk of the intrusion, contains from about 50 to 300 ppm of uranium. Fission-track radiography of thin sections from surface samples of a uranium mineralized occurrence in east Greenland disclosed the general association of U with limonitic material in fluoritized zones. Contents in these zones varied from several hundred to several thousand ppm U, depending on the degree of limonitization.

### Other Elements

The use of radioisotope excited X-ray fluorescence analysis for the determination of a variety of elements in powdered rock samples was continued.

A measurement system based on a high-resolution lithium-drifted silicon detector is routinely used together with a  $Cd^{109}$  excitation source for getting information on the abundances of Rb, Sr, Y, Zr, Nb, and Mo in samples collected in various places in Greenland. A single measurement typically lasts 400 seconds. Data reduction involving calculation of peak areas is normally preferred because of its simplicity.

$Am^{241}$  is another useful radioisotope which furthermore permits determinations of rare-earth elements. An X-ray spectrum obtained by excitation of a sample from the Ilímaussaq intrusion with the 60 keV gamma-rays from an  $Am^{241}$ -source is shown in fig. 4.

To form a reference data library for future mineral prospecting in Greenland with portable X-ray fluorescence analysers, calibration experiments with the EKCO Mineral Analyser were made. Thus, series of powdered samples containing known amounts of Zr, Nb, Mo, La, Ce, Pb, Cu, and Zn

were measured various excitation sources being used. The calibration curves obtained cover the range of contents from a few tenths to several percent. From the calibration curves we determined limits of detection which were low enough to make the instrument applicable for mineral prospecting purposes.

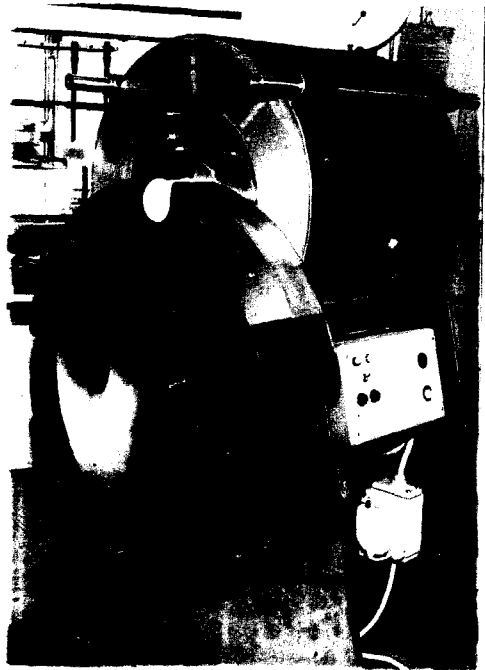

Figure 3. Automatic gamma-ray spectrometer for the determination of U, Th, and K in powdered rock samples. The magazine for the sample containers and the end shields were removed when the photograph was taken.

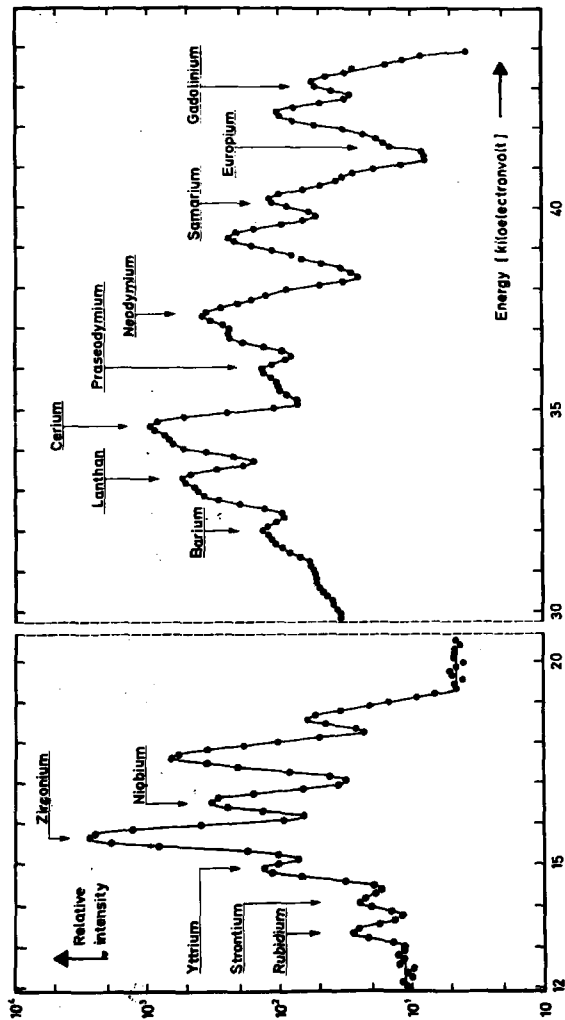

Figure 4. X-ray spectrum of a powdered rock sample from the Ilmaussaq intrusion in southern Greenland. The sample was irradiated with gamma-rays from an  $Am^{241}$  source, and the fluorescence X-rays were detected by a lithium-drifted silicon-detector having an energy resolution of about 250 eV.

## RESEARCH INSTRUMENTATION

Short accounts are given of the work on the data handling system for the Isotope Laboratory, of the introduction of CAMAC, of the work on the triple-axis-spectrometers and of a system for reactor reactivity measurements. Some other subjects: pulsed radiolysis, micrometeorology, electrical noise, the use of lasers for flow measurements and work on the cold neutron source are briefly mentioned. A barometer with digital read-out is described in some detail as well as a system for water film measurements. Finally a survey of the EDP needs of the experiments at Risø is given.

The programming work for the data handling system for the Isotope Laboratory made good progress, while the work on the hardware was delayed by late deliveries. A number of malfunctions was experienced when the software produced on the FDP-8 programming facility of the department was tested on the system. The malfunctions were found to be due to hardware limitations not clearly stated in the early DEC literature used as the original design basis. The system had grown so big that both transmission time and bus line loading had become too large. The system therefore had to be re-arranged to bring the total cable lengths below the permitted 15 m and repeaters introduced on one of the bus line branches.

The interface between the two magnetic-tape stations and the computer is finished and tested outside the system.

The Isotope Laboratory has been advised on the purchase of a gamma-detector system. The Ge-detector has been delivered, while the 1024-channel analyser should arrive in April.

It has been decided to let the internationally accepted instrumentation standard CAMAC replace the control and data acquisition systems used at present. A mobile equipment for micrometeorology and a triple-axis-spectrometer are the first systems being produced in the new standard.

The specifications of the new triple-axis spectrometer of the Neutron Physics Group, TAS-6, have been worked out. NIM-modules will be used for the nuclear instrumentation, while the control instrumentation will be in CAMAC. Some new CAMAC modules have been designed and are ready for production. The experiment will be controlled by a PDP-8/e computer. The programming has commenced, and maximum use is being made of the existing TAS-programmes.

Some minor changes have been made in both soft- and hardware on the existing spectrometers. TAS-4 and TAS-5 have no computers. A program has therefore now been made for the TAS-3 computer which permits the calculation of the settings of TAS-4 and TAS-5. This is done without disturbing the normal running of TAS-3, and the data are transferred between the spectrometers by means of fast paper tape equipment.

The reactivity of the DR 3 reactor was to be measured as a function of the position of the control rods. The results should be in a form suitable for EDP. The procurement of a complete data recording system for this purpose only could not be justified, however, as the measurements were few and far between ( a few minutes once a month ). The signal from the ion chamber used for the measurement was therefore to be taken to the recording equipment of the Section of Experimental Technology some two hundreds metres away.

Ground loop currents between the ion chamber and the data handling equipment made the measurement difficult. The ground loop was broken by feeding the output of the current-voltage converter connected to the ion chamber to a differential amplifier. Two channels with a gain ratio of ten are used in parallel to obtain both high resolution at small signals and a wide measuring range.

The installation of the pulsed radiolysis system is almost completed. The possibilities of direct data transfer to a small computer are investigated.

The stationary micrometeorological system is under installation. It should be ready in May. The mobile equipment is under construction. It is expected to be finished late in the year.

A working group on electrical noise has been formed to collect the experiences in reducing electrical noise. The work of the group should result in guide rules for both instrument design and systems installation.

The investigation of the use of lasers for velocity measurements in two-phase flows continues. An optical system giving an optimal signal to noise ratio has been developed. The theory of measuring the multidimensional velocity vector is being studied.

The design of the instrumentation for the cold neutron source is now finished. Most of the equipment has been procured. The original plans had to be changed considerably, one of the neutron filters has for example been left out by the Physics Department. The complete system, taking up four

and a half 19"-racks and a 1.5 m long desk, is expected to be ready for testing in the autumn.

#### DIGITAL READ-OUT FOR ANEROID BAROMETER

A system Paulin AB type IB-B-01 barometer has been modified for use in the stationary micrometeorological equipment. The modification consists in adding a shaft-digitizer to the mechanical read-out counter of the barometer. The digitizer is followed by the electronics necessary to perform the serial read-out demanded by the data logging equipment.

The principle of the barometer is shown in fig. 5. A servo system keeps the pressure on the springloaded bellows constant. The atmospheric pressure changes are compensated for by changing the spring load so as to keep the position of the top of bellows constant. The revolutions of the spindle tensioning the spring are registered on the counter to which the digitizer is connected.

The range of the barometer is 850.0 - 1050.0 mb and a 100-turn, 20,000-step, digitizer is used. The gearing between digitizer and barometer is so selected that 10 full revolutions, 2000 steps, correspond to the range of the barometer. The relation is:

Digitizer position:	0	, 2000
Barometer reading:	850.0	, 1050.0 mb.

The accuracy of the barometer  $\pm 0.3$  mb and a timing circuit limits the time between readings to four minutes to allow tracking of slow variations within the deadband of the servo system.

The electronic part of the barometer is shown in fig. 6. The anti-ambiguity circuit and the 16-bit register are the read out part for the digitizer, while the rest of the circuit performs the parallel-to-series transformation necessary for the transport to the datalogger.

The output of the digitizer is read into the register when a read-out signal is received from the position detector of the barometer. The parallel-series transformation is done by the equal-count method. The pulse train representing the barometer reading is transmitted at 2 MHz and lasts less than 1 ms. The pulses are stored in binary form in the input register of the data logger and take part in the next read-out scan.

The barometric channel is slightly different from the others, described in Risø M 923, in the way the signals are treated. The barometric data are only sampled, while the data in the rest of the channels are averaged over intervals selectable from 5 ms to 30 min.

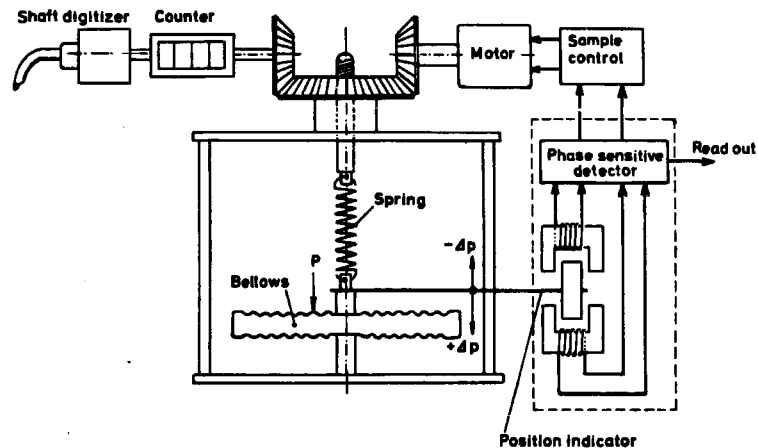

Fig. 5. Digital Barometer: Principle

WATER FILM MEASUREMENTS

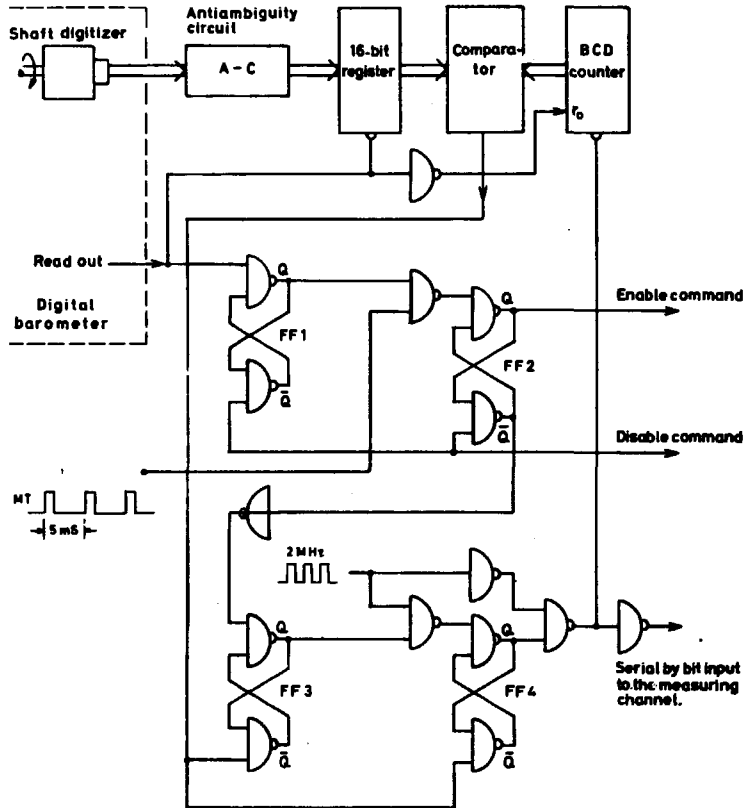

Fig. 6. Read-out electronics for the digital barometer

AB Atomenergi (Sweden), Institutt for Atomenergi (Norway) and Atomenergikommisionen (Denmark) are running a combined experimental and theoretical water research program for the development of a subchannel computer program.

The experimental steam-water program covers subchannel experiments with both a 7- and a 9-rod cluster element, together with film flow experiments in annulus geometry.

The Danish annulus experiments are again based upon a close and up till now successful commercial co-operation between Risø and Laboratory of Reactor Technology at the Royal Institute of Technology in Stockholm, where a 0.8 MW heat transfer loop is available in which the Danish test section is installed and the actual experiment performed.

The measurement of the water film on the surface of the rod is performed by the needle method.

A DC-voltage is applied to the simulated fuel rod and thereby the water film. A fraction of the voltage is measured by needles moving radially to the rod at representative positions. The needles are connected to indicators measuring the distance relatively to the rod. The potential of the needle depends on the contact to the water film.

The movements of the water film will cause intermittent contacts at the needles. The film thickness may be determined from the number of contact closures and the integrated contact time.

Fig. 7 is a schematic diagram showing the instrumentation.

The rod is heated by the current from the 800 kW transformer. A DC-voltage, -12V, is fed into the movable contact of a potentiometer R, which is connected to both ends of the test rod. R and the rod form a bridge circuit which compensates for the 50 Hz component of the needle potential. A part of the DC-voltage is fed to the amplifier every time and as long as the needle is in contact with the water film.

A voltage level detector with hysteresis cuts off the noise, generating pulses with a constant amplitude. An optical coupler, made necessary by different ground-potentials in the set-up, transfers the pulses to the recording system. The pulses are fed through a monostable multivibrator to scaler (1). Scaler (1) thus registers the number of contact closures during the measuring time.

The pulses are also used for gating 10 k Hz pulses to scaler (2). Scaler (2) thus records the integrated contact line. The counts of the scalers are printed out at the end of the measurement period.

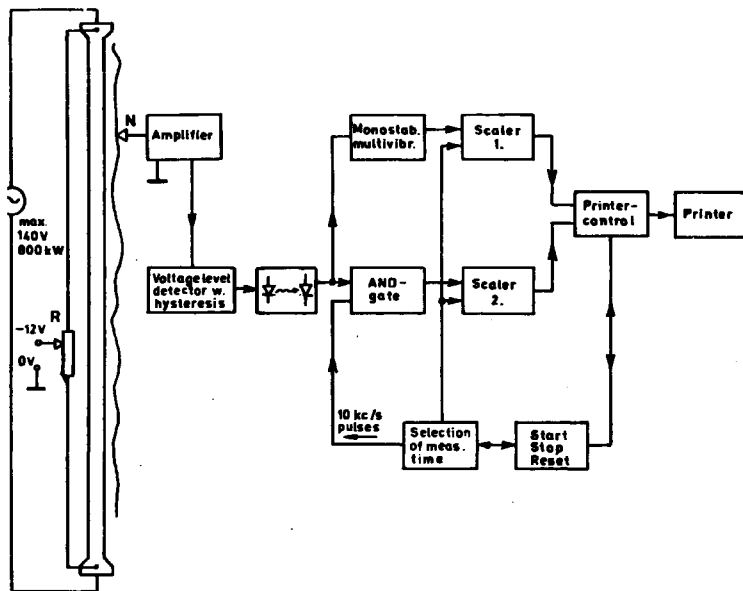

Fig. 7 Instrumentation for film thickness measurement.

## ELECTRONIC DATA PROCESSING FACILITIES

needed at Risø for experiments and instrumentation until 1976.

This survey was based on:

- statistics of the use of data processing in the instrumentations until now.
- information on experimental work at Risø.
- prognoses of the technical development.
- knowledge of the work and means of the department.

### Historic and Future Development

The statistics of small computers, PDP-8s, at Risø are illustrated in fig. 8. The curve suggests a steady increase of three per year. The computers have mainly been used in instrumentations because of the possibilities they offer regarding automatic control and data collection. They are for example used for neutron spectrometers, heat transmission experiments and activation analysis. A number of future uses are foreseen as the number of spectrometers increases and irradiation and reactor instrumentation is modernized.

Special data recording equipment collecting large amounts of data in a short time has been developed alongside the small computers. It is, however, characteristic of this equipment, e. g. multichannel analysers and data loggers, that in recent years the trend has been to adapt small computers to these purposes. Further needs for data processing will arise when the ultra fast digital techniques necessary for pulsed radiolysis and plasma physics measurements are developed.

### EDP-Needs of Typical Instrumentations

Small computers and specialized computers, e. g. multichannel analysers, are used for data demanding experiments. The data collecting needs of some experiments, e. g. neutron spectrometers, activation analysis, health physics and mineral prospecting, seem, however, to be more or less fulfilled for some time to come. The experimenters' demands are now more directed towards "on the spot" data reduction and evaluation. This local data processing is necessary to facilitate an intelligent judgement of the results and planning of the next measurement.

The need for local data treatment is typically found at the neutron spectrometers, in isotope analysis, pulsed radiolysis and plasma physics. Pulsed radiolysis and some plasma physics experiments are typical, single-event

experiments where the amount of collected data and necessary calculations is fairly small. It is, however, important for the experimenter to have the results processed immediately to be able to plan the next measurement. These needs are best fulfilled by a terminal connected to the central computer, this being the cheapest way to provide the necessary computing power.

The small computers used at present only serve data collecting and control purposes. The computing power has to be increased to permit a faster delivery of the results. The increase may be made by improving the local computer facilities, by providing terminals connected to the central computer or by a combination of both.

Electronic data processing has been needed for a long time for the irradiation experiments and the reactor instrumentations. It would make the planning and the running of these installations easier and provide a better service for customers. Safety and reliability are, however, paramount factors in these cases, and a natural conservatism has been displayed. So much experience has been gained, however, with EDP that the application to these experiments will be both technically and economically justified.

It is certain, because of the technological development and present possibilities, that graphical displays must be taken into account when you consider the above evolution. The ability of the graphical displays to show not only text but also curves and figures makes them very helpful in the evaluation of e. g. energy spectrums. The displays will also be a necessary tool in the work of planning and documenting instrumentations and process systems. Systems simulation and safety evaluation exemplify fields where large numbers of variables are used. The graphical display will be very important in these fields by permitting a running, intelligent evaluation of structures and consequences of error.

Conclusion

A steady improvement of the data processing facilities is necessary if the experiments are to keep their position in the frontline. The demands may be evaluated from the techniques now used, present day technology and future possibilities. The table gives the forecast for the two periods 1972/74 and 74/76; terminals to the central computer are supposed to be available in 1972.

Buying period	72/74		74/76	
	Number	Price D kr.	Number	Price D k
"Tele-type" terminals	9	54,000 (1)	5	100,000
Computer terminals	4	120,000	4	80,000
Graphical displays	5	400,000	6	480,000

(1) existing printers taken into account.

In addition to this the instrumentations will include the necessary small computers.

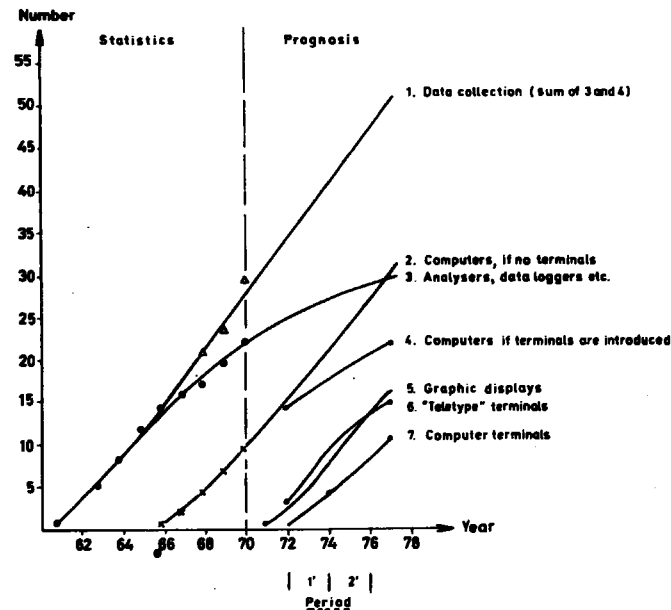

Fig. 8. Trends of the total number of EDP-units used for experimental research and technology at Risø.



## PROCESS CONTROL

In order to meet process control requirements, an electronic controller was developed. The controller which operates 42 separate on-off channels on time basis, can be programmed to run through an arbitrary sequence of the possible  $2^{42}$  output configurations.

The program is stored on a 1-inch punched tape. The channel information is arranged in blocks of six 7-bit words. Each block is followed by one or more 8-bit words, which provide the timing information. The time intervals can be programmed with a resolution of 1 sec.

The generation of the punched tapes is facilitated by a computer program which also permits easy editing.

The controller is contained in two 19" standard crates, mainly occupied by reader, control panel and display. The electronic circuitry is based upon integrated TTL logic.

## MISCELLANEOUS

During the period, the department has co-operated with several institutions and firms. The subjects ranged from advisory assistance to external examination at the Technical University. Lectures given by staff members are listed at the end of this report.

The department was for a number of years dispersed in several buildings with distances of some 150 m between related groups. This situation, which did reduce contacts between the groups, was brought to an end in January 1971 when an extension of the old department was ready.

The new building has a total floorage of  $1800 \text{ m}^2$ . The two upper storeys house the three development groups, Systems Techniques, Research Instrumentation and Nuclear Geology, while the basement is occupied by the Central Instrument Store. The old building,  $750 \text{ m}^2$ , houses the Maintenance Group, the Construction Group, workshops etc. The department is now again able to receive guest workers.

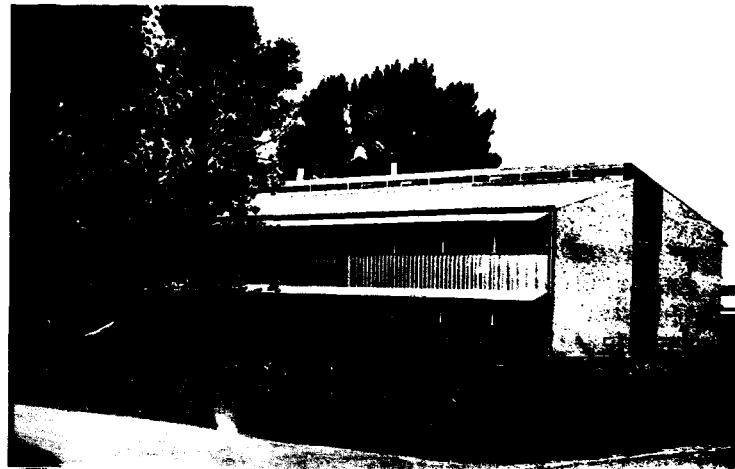

Fig. 9. The extension of the Electronics Department. The Risø standard module,  $3 \times 6 \text{ m}^2$ , was used for the building.



Fig. 10. The laboratories and offices of the single groups are concentrated in landscapes providing direct contact between the offices and the laboratory. The balcony is used for opto-electronic and other experiments requiring relatively quiet conditions.

LECTURES, PUBLICATIONS, VISITS ETC.

Lectures

- 9 October 1970. Jens Rasmussen: Den menneskelige faktor i drift-sikkerheden af industrielle proces anlæg. Elektroteknisk Forening.
- 14 November 1970. K.Søe Højberg: Regulering, konstruktionsprincipper, Ingeniørsammenslutningen.
- 29 January 1971. K.Søe Højberg: Renogram test simulering. Symposium on the Application of Computers in Medicine.
- 19 February. H. Kunzendorf lectured on "Nuclear Techniques for the Determination of U, Th, K, and Be in the Ilímaussaq Intrusion, South Greenland" at Abteilung für Angewandte Lagerstättenlehre, Technische Hochschule Aachen.
- 17 March. Lars Lading: Two-Phase Flow Measurements Utilizing Laser Anemometry, Symposium on "The Study of Flow and Turbulence by Laser Doppler Techniques". University of Warwick.

During the period, B. Runge has lectured at the Technical University of Denmark, on ALGOL-W and FORTRAN programming for the NEUCC 360/75.

L. Løvborg, H. Kunzendorf, and H. Wollenberg have lectured on nuclear geophysical methods for students from the Institute of Geology of the University of Copenhagen.

Publications

- 1. Semi-annual Report for the Period 1 April - 30 September ( Risø-M-1357).
- 2. P. la Cour Christensen, Beskrivelse af et proceskontrol datamat-system ( Risø-M-1363).
- 3. Lars Lading, Two-Phase Flow Measurements Utilizing Laser Anemometry. ( Risø-M-1368 ).
- 4. Chr. Fog, Computer-controlled Instrumentations for Measurements of Heat Transfer ( S-4-70).

- 5. Lars Lading, The Differential Doppler Heterodyning Technique, Applied Optics, 10, 1943-1949, ( 1971 ).
- (-) H. Kunzendorf and H.A. Wollenberg, Determination of Rare-Earth Elements in Rocks by Isotope-excited X-Ray Fluorescence Spectrometry, Nuclear Instruments and Methods, 87 ( 1970 ), 197-203.

Further References

- 6. E. R. Woodcock, The Calculation of Reliability of Systems, The Program NOTED. ARSB (S) R 153.
- 7. SEAS report: Beskrivelse af programsystemet til Stignæs EDB procesanlæg ( april 1970 ).
- 8. SEAS report: EDB procesanlægget, SEAS, Stignæsværket. ( Januar 1971 ).
- 9. R. Hooke and T.A. Jeeves, Direct Search Solution of Numerical and Statistical Problems. Journal of the Association for Computing Machinery 8 ( 1961 ).
- 10. Roger L. Barron, Inference of Vehicle and Atmosphere Parameters from Free Flight Motions. AIAA Guidance, Control and Flight Dynamics Conference Huntsville, Alabama, August, 14-16 ( 1967 ).
- 11. Kurt Rasmussen, Optimalisering. Eksamensprojekt, København Teknisk ( 1971 ).
- 12. Semi-annual Report for the Period 1 April - 30 September 1969. ( Risø-M-1206 ).

Meetings etc.

- 29-30 January. In co-operation with Medicoteknikudvalget: Symposium on the Application of Computers in Medicine.
- 12 February. Danish Automation Society. Introduction to CAMAC, Mini-Computer Applications.