

## Effects of Glass Fibres on the Properties of Micro Moulded Plastic Parts

**Islam, Aminul; Hansen, Hans Nørgaard; Gasparin, Stefania; Bondo, M.**

*Published in:*  
Commercial Micro Manufacturing Magazine

*Publication date:*  
2011

*Document Version*  
Publisher's PDF, also known as Version of record

[Link back to DTU Orbit](#)

*Citation (APA):*  
Islam, A., Hansen, H. N., Gasparin, S., & Bondo, M. (2011). Effects of Glass Fibres on the Properties of Micro Moulded Plastic Parts. *Commercial Micro Manufacturing Magazine*, 4(7).

## DTU Library

Technical Information Center of Denmark

---

### General rights

Copyright and moral rights for the publications made accessible in the public portal are retained by the authors and/or other copyright owners and it is a condition of accessing publications that users recognise and abide by the legal requirements associated with these rights.

- Users may download and print one copy of any publication from the public portal for the purpose of private study or research.
- You may not further distribute the material or use it for any profit-making activity or commercial gain
- You may freely distribute the URL identifying the publication in the public portal

If you believe that this document breaches copyright please contact us providing details, and we will remove access to the work immediately and investigate your claim.

# Effects of Glass Fibres on the Properties of Micro Moulded Plastic Parts

A. Islam, H. N. Hansen, S. Gasparin, Department of Mechanical Engineering, Technical University of Denmark and M. Bondo, Sonion A/S

## Introduction

In the current state of injection moulding technologies micro injection moulding is an immensely important process for industries and the technology is growing at a rapid speed. The need for micro parts in the industries is on the rise and the demand for tailor made materials with specific parameters becomes larger. One effective and economic way of mass production for micro parts is injection moulding and the used materials for the process are mostly plastics because of their suitability for injection moulding, good replication quality and cost. Nevertheless, plastic materials lack stiffness and mechanical strength. The most common way to improve the mechanical properties of a plastic material is to add glass fibres. Glass fibres improve the >

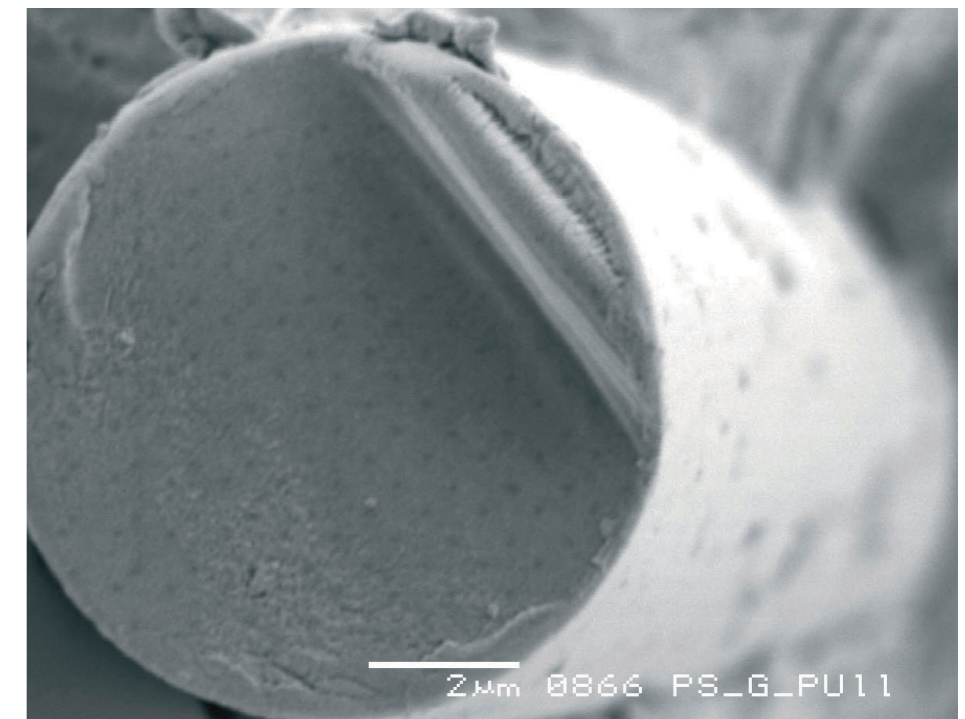
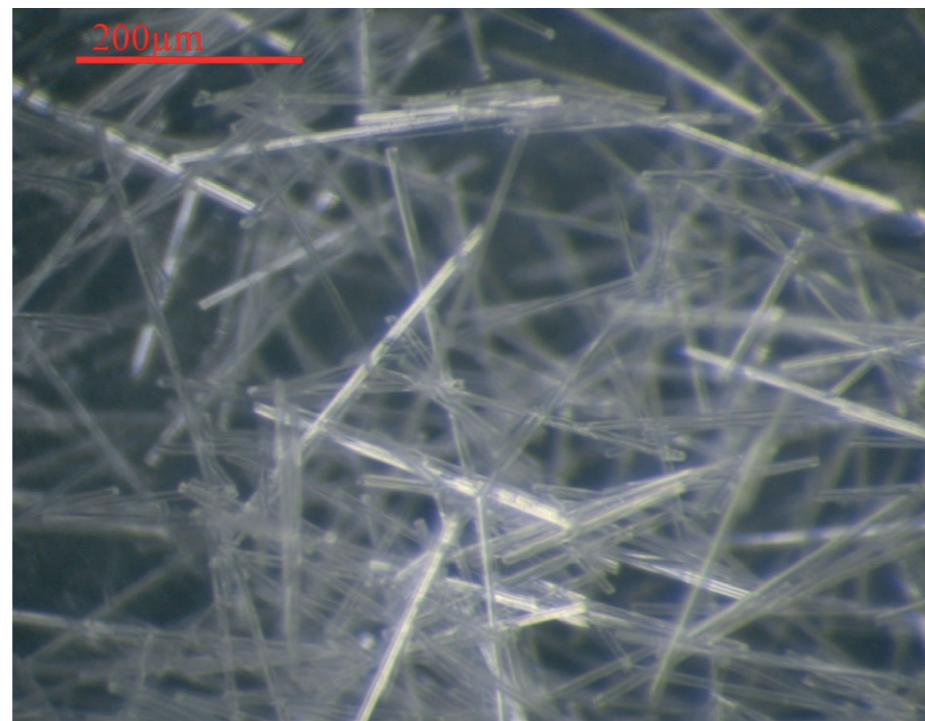

Figure 1: Picture of glass fibres (left picture), magnified view of one single glass fibre (right picture).





structural properties like strength, stiffness and reduce the shrinkage of the part [1]. Glass fibres used in plastic materials are distinguished as short glass fibres and long glass fibres. Typical lengths of short glass fibres are 0.2 to 0.5 mm and for long glass fibres, 10 to 15 mm. Short fibre reinforced thermoplastics are most commonly used for injection moulding [2]. Although all thermoplastics can be reinforced with fibres, Polyamide, Polypropylene, Polystyrene, ABS and SAN are the most widely used fibre reinforced materials in the plastic industries [2]. Figure 1 shows the short glass fibres used with thermoplastic materials. The right picture of the figure 1 shows the cross sections of an individual glass fibre. The pictures were taken by Scanning Electron Microscope during the experiment of current investigation.

Mechanical properties of glass fibre reinforced plastics can vary depending on the fibre distribution, fibre orientation, fibre size, fibre fraction, fibre-plastic adhesion etc [2]. Glass fibres are used as reinforcing materials in many sectors like automotive and naval industries, sport equipments, airplane industries and in many other plastic industries. Glass fibres improve the mechanical properties of plastic materials; on the other hand, they also impart some unwanted conditions and properties in the process and in the product, especially for micro moulding and for micro products, for example poor replication

and surface finish, filling problems and so on. The investigation carried out in this paper reveals the effect of glass fibres on the replication quality and surface properties of the micro moulded plastic parts.

## Experiments

The aim of the current study is to investigate the effects of glass fibres on the replication quality of thin polymeric ribs. The geometrical size effect on the amount of glass fibre in the moulded plastic parts was also investigated in the experiments.

## Test geometry

The test specimen used for this experiment (shown in figure 2) was 2.5 dimensional having long ribs with different aspect ratio. Different rib thickness of this geometry will simulate the different filling behaviour of the glass-filled material. The section of the part shown with the red circle is termed as the critical section of the part as it has sharp corners and the thinnest cross section with an aspect ratio of nine. >

Name	Glass	Manufacturer	Moulding condition		
			T <sub>mo</sub>	T <sub>me</sub>	V <sub>in</sub>
PS 158K	0%	BASF	60°C	235°C	102 mm/s
PS 158KgF30	30%	BASF	60°C	235°C	102 mm/s

Table 1: List of plastic materials.

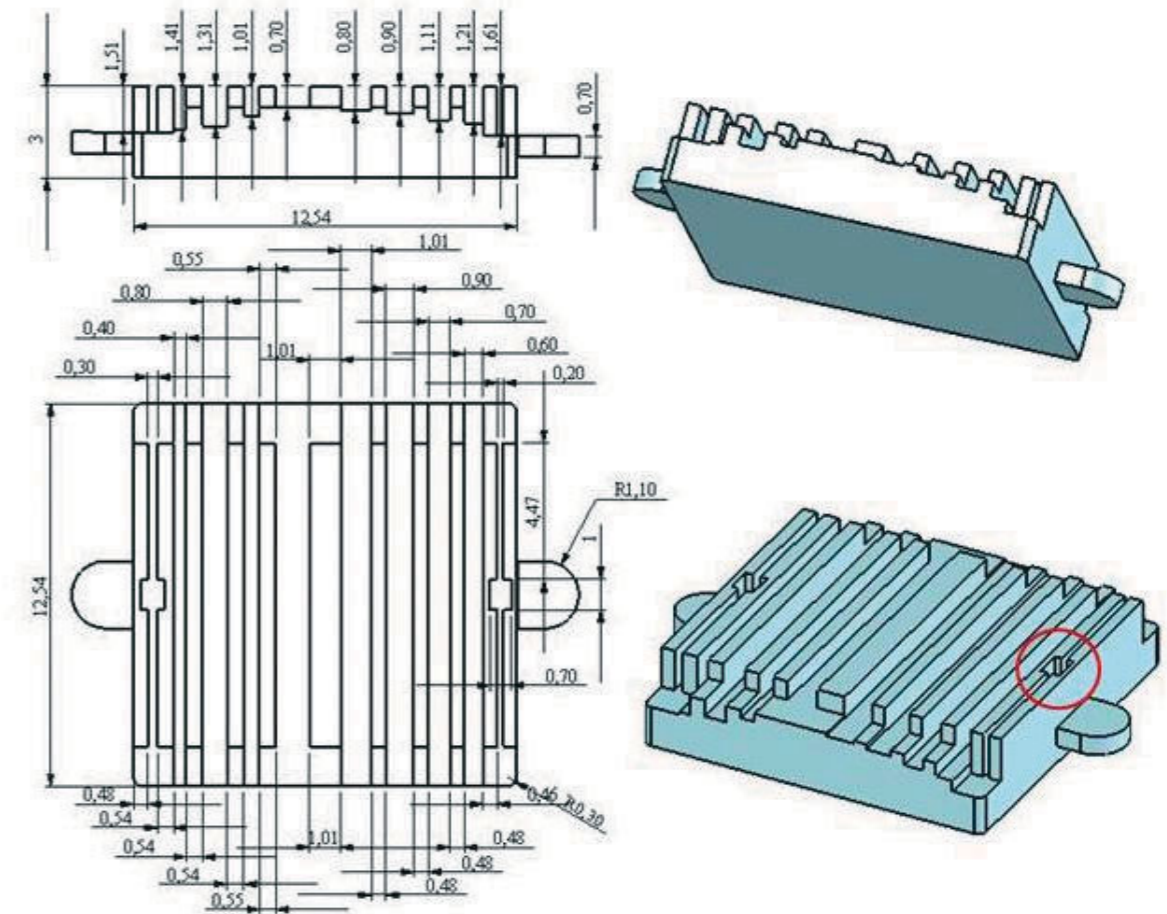

Figure 2: Part geometry used in the experiment (critical section of the part is shown with the red circle).





Figure 3: Injection moulding machine used for moulding of the plastic parts (left), and the moving side mould with cavity (right).

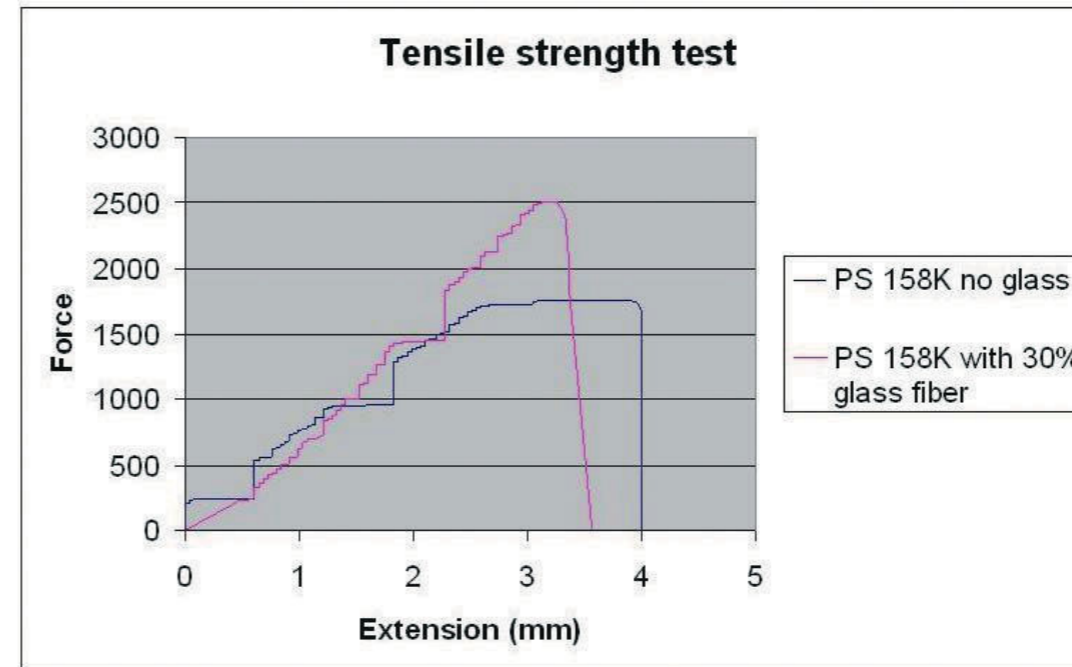

Figure 4: Tensile test performed on ISO standard tensile bars —samples are made with and without glass fibres.

### Plastic material used in the experiment

Two commercial Polystyrene (PS) materials were used for the experiment. The decision to choose PS material was down to the availability on the same grade, with only difference in the content of glass fibre. PS is also one of the commonly used industrial thermoplastics. The specification of the materials and their important injection moulding process parameters used in experiment are listed in table 1.

### Moulding machine and process

The mould and machine used for the experiment are presented in the figure 3. The moulding machine was an Engel ES 80/25 HL-Victory and the mould was produced by Wire Electro Discharge Machining.

### Result and analysis

#### Mechanical strength

As mentioned before glass fibres increase the mechanical strength of the moulded plastic parts. Injection moulding of ISO standard tensile bars with and without glass fibres confirms the effect of glass fibres on the mechanical strength of the materials. The results are plotted in figure 4 and it shows there is a significant increase of mechanical strength due to the addition of glass fibres.

The calculation shows that approximated increase in strength due to the addition of 30% fibres to the PS material is 24%. Figure 5 shows the broken surface of the moulded part after tensile testing which shows that the broken surface is

smooth in case of non-filled material. The broken surface with the glass filled material is very irregular. This indicates that glass fibres actually change the fracture plane or slip plane of the plastic materials and dislocated it to make a stronger failure surface [3].

Besides influencing the mechanical strength, glass fibres also decrease the elasticity of the material and make it stiffer. For this reason, it can result in cracks on the micro features of the part during de-moulding like the crack visible in figure 6. The pictures were taken on the critical sections of the moulded parts.

### Surface quality

Addition of glass fibres increases the >





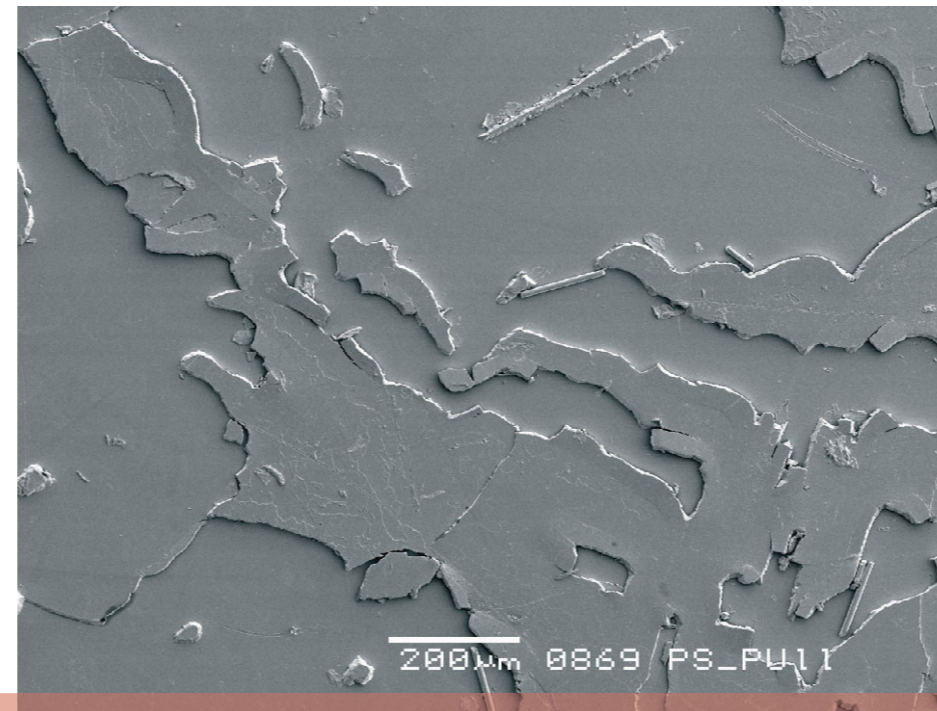
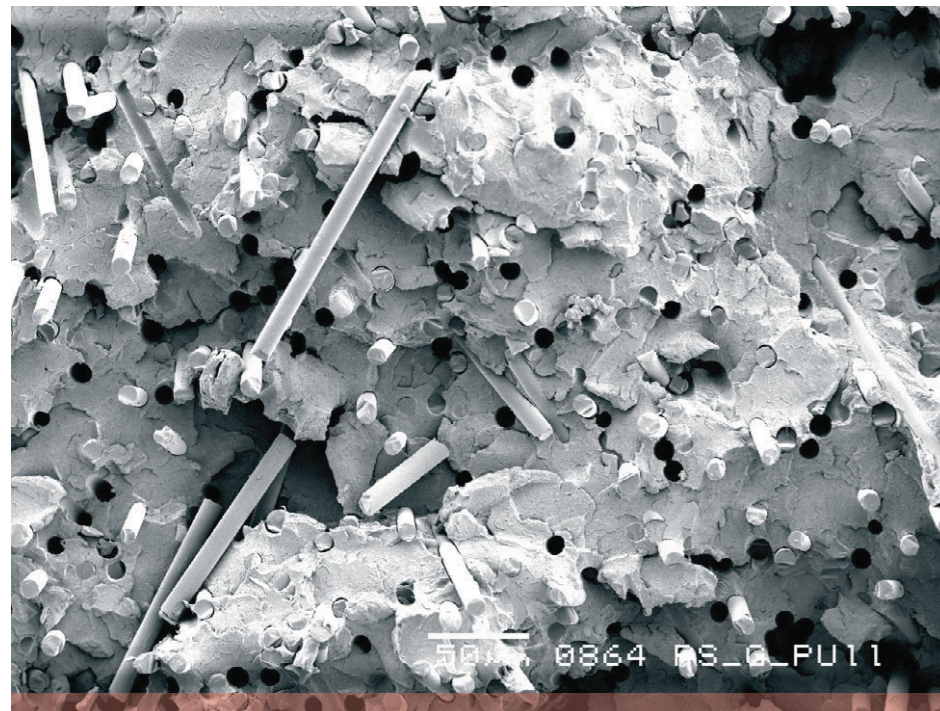
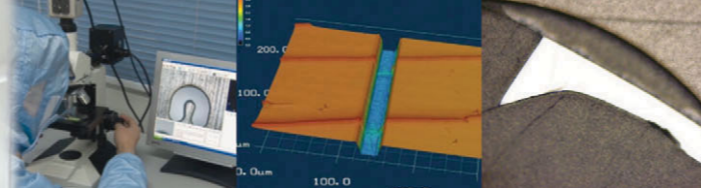

**Figure 5: Broken surface of PS moulded tensile bar after tensile testing (left hand side picture—taken on the sample with glass and right hand side picture —taken on the samples without glass).**

roughness of the plastic parts. In the experiment, a big difference on the surface roughness of the moulded plastic parts was observed based on the glass fibres. The average surface roughness measured on the moulded part with PS with glass fibre was about  $7.84 \mu\text{m}$  and roughness of the part moulded without glass fibre was about  $2.58 \mu\text{m}$ . The surface replication of PS without added glass fibre is close to the actual mould surface. In addition, the glass fibre not only increased the average roughness but also the span between the maximum and minimum height of the samples is increased [2].

A clear difference in the surface of the part is visible based on the glass fibre in the material. The part with the glass fibre material is rougher compared to the other part surface. There is also difference in the edge sharpness and weld line formation based on the amount of glass fibre in the plastic materials. When a smooth surface and minimally visible weld line are desired, materials without glass fibres are recommended. Figure 8 shows the difference in replication quality of the critical section of the part with and without glass-filled materials.

### Fibre distribution and orientation

To investigate the amount of glass fibres and their directional orientation at different sections of moulded part, the part moulded with glass filled PS material, was cut in three different sections (shown in figure 9): one was close to the gate; another one was far from the gate and one in the middle where the critical sections are placed.

Each section was then grinded, and investigated under light optical microscope. Approximate location of the investigation is shown in the following figure; the spot size was  $325 \mu\text{m} \times 250 \mu\text{m}$ . Pictures taken by light optical microscope at three different sections are shown below.

It is clear that there is difference in the distribution and amount of glass fibres, since all pictures have the same size and resolution. Approximate counts of glass fibres are 166, 88 and 41. In the section close to the gate, the fibres are orientated along the longitudinal direction of the initial flow. Far from the gate, fibres are less organised. To calculate the exact area covered by glass at different sections of the moulded part, the software package Scanning Probe Image Processor (SPIP) was used. SPIP located and mapped the glass covered area as shown in figure 11 and automatically calculated the total area and the area covered by glass fibres. The >





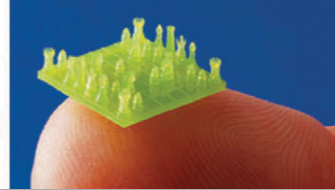

results are presented in table 2.

It shows that there is a difference in the percentage amount of glass fibres at various cross sections based on their distance from the gate.

To investigate the influence of micro geometry on the distribution of glass fibres, the cross section of the thinnest rib (shown in figure 12) was investigated again at three different sections based on the distance from the gate. The glass fibre distribution can be seen in figure 12. There is also a difference in the amount of glass fibres based on the location of the cross section (approximately 77, 61, and 50). The amount of glass fibres in this thin rib is much smaller, than the amount of glass found in the thick section of the part when the observation was made on the same size of cross sectional area.

Same calculation was done with SPIP to determine the exact area covered by glass. The mapped picture by SPIP is presented in figure 13 and results are presented in table 3. These also agree with the previous result found in case of thick rib. That means the fibre distribution is different at different sections of the moulded part and depends on the distance from the gate of the moulded specimen.

A separate investigation was conducted to find the effect of injection moulding process on the length of glass fibres. Injection moulded PS parts were dissolved in solvents (in this case a combination >



Figure 6: Effects of glass fibres on micro cracks of the injection moulded plastic parts (Part without glass fibre — left, part with glass fibre — right).

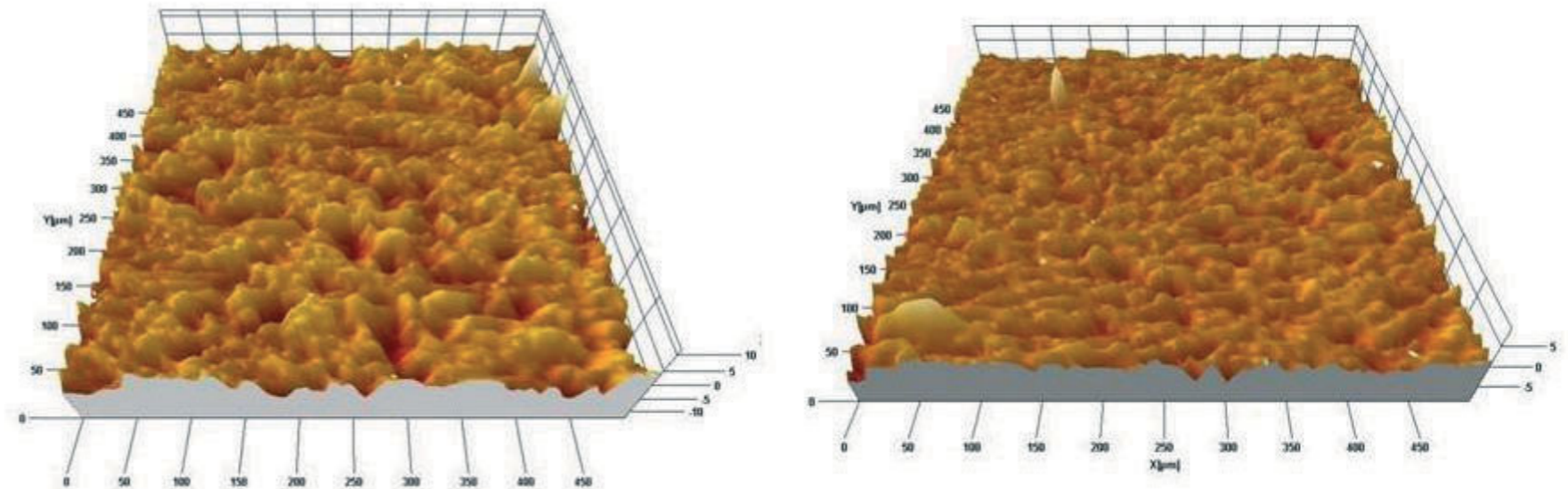

Figure 7: 3D picture of the moulded surface (part surface with glass fibre, left, and part surface without glass fibre, right).





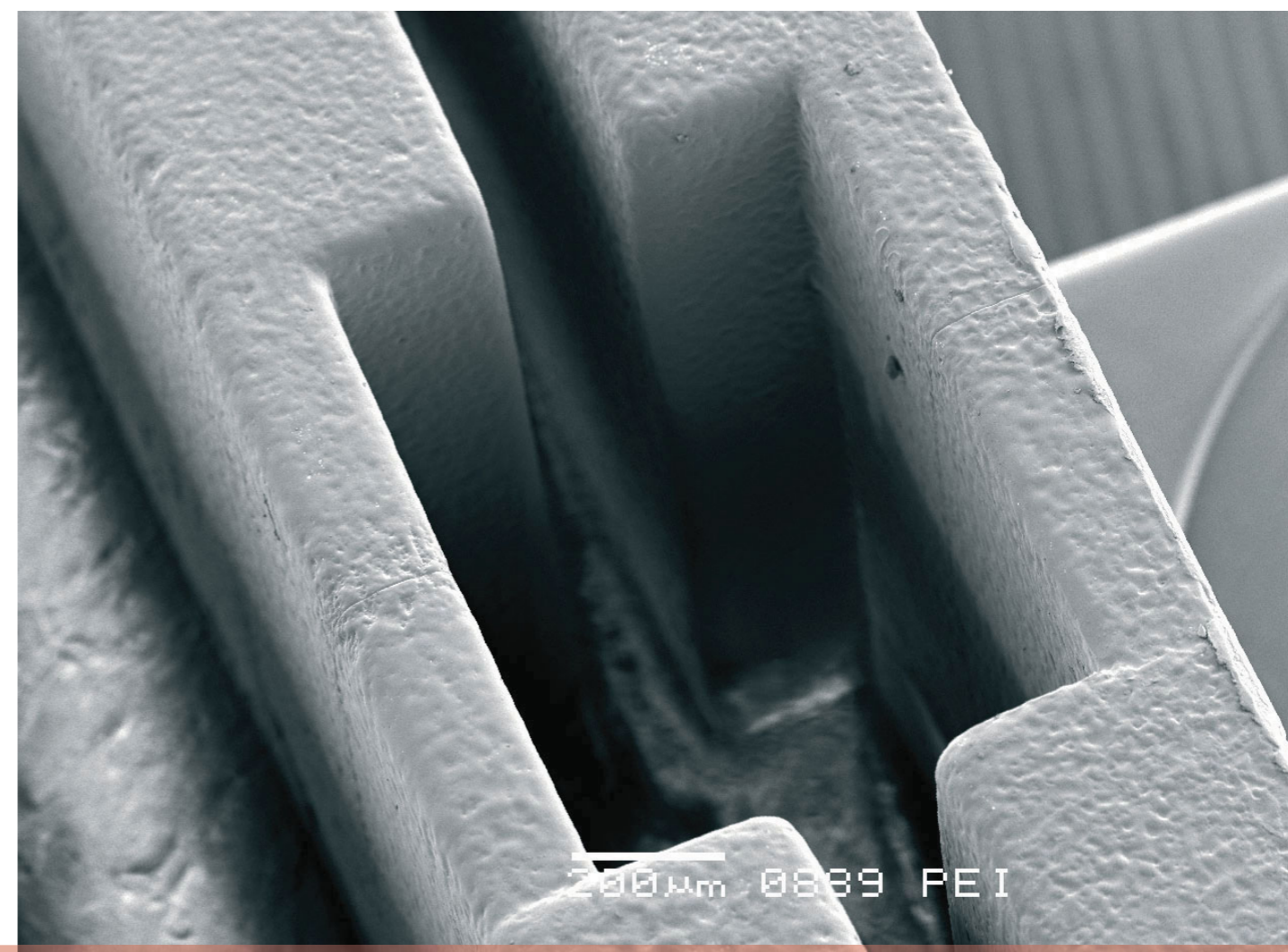
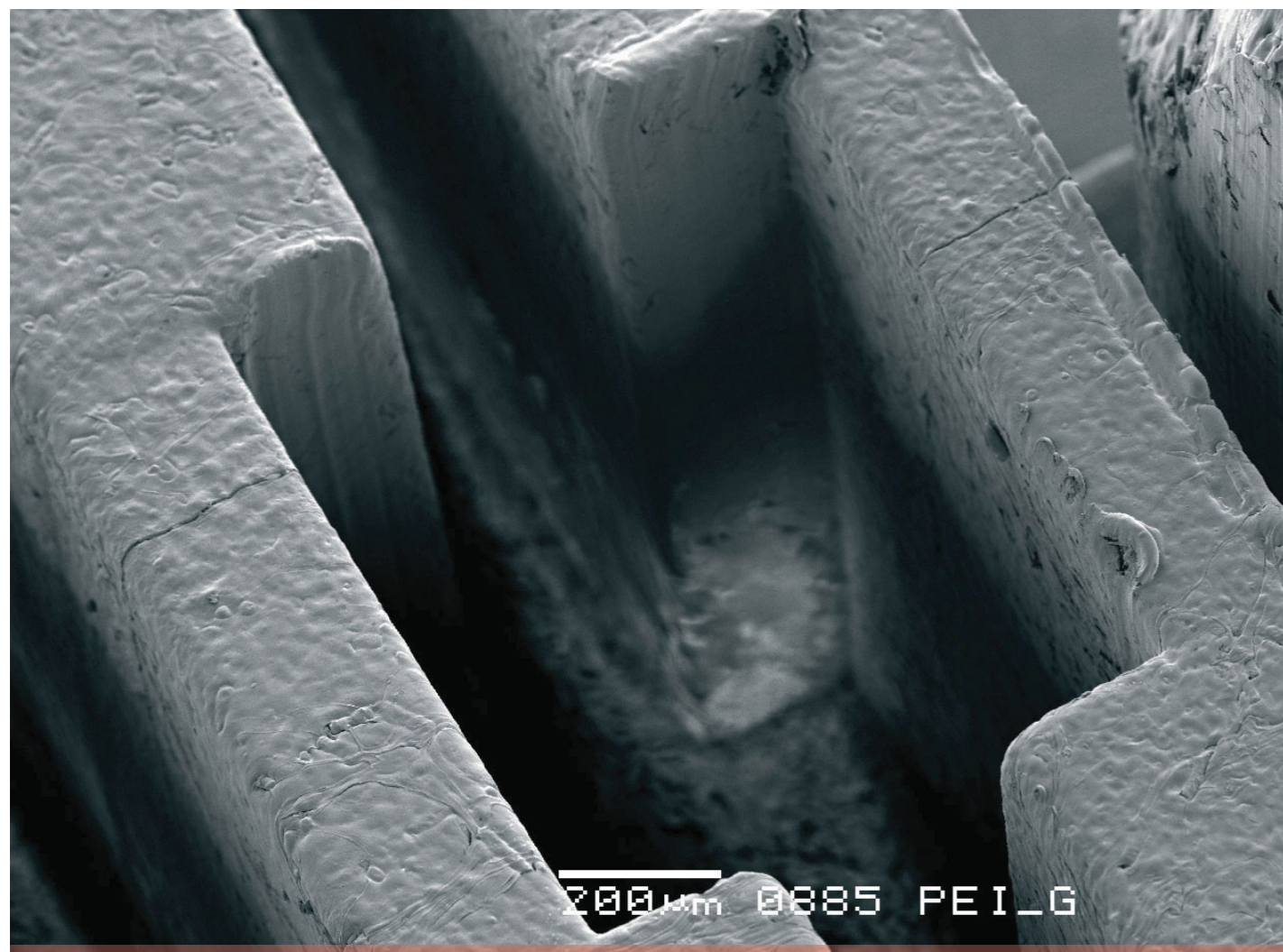
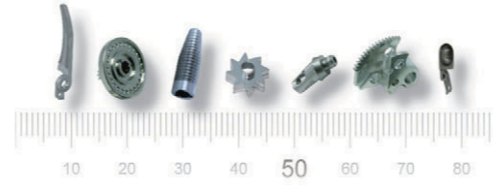

Figure 8: Surface of critical section of moulded part — PS without glass fibre (left) and PS with glass fibre (right).





of Acetone and Tetrahydrofouside was used) and afterwards the liquid was filtrated to separate the glass fibres from the liquid. Then the length of the glass fibre was measured and the average length was about  $400\ \mu\text{m}$  and the average diameter was about  $10\ \mu\text{m}$ . The same measurements were performed for the glass fibres collected from the plastic granulate and almost no difference was observed. This suggests that there was no significant change in the length of glass fibres due to the injection moulding operation. Figure 14 shows the glass fibres collected from the plastic granulate and from the moulded plastic part respectively.

### Summary and conclusion

From the investigations, it is visible that the density of glass fibres in different sections of the plastic part depends on the location of the gate. It is also visible that part geometry has influence on the fibre distribution. The thinner a part or part section is, the lesser amount of fibres is distributed in the part or in the part section. This

non-homogeneous fibre distribution imparts non-symmetric mechanical properties in moulded parts. The addition of glass fibres in the plastic increases the material stiffness and the added stiffness affects the material's ability to be ejected from the mould without creating permanent defects on the specimen.

The results clearly show that if the same process condition is used to mould plastic parts with and without glass fibre, the result will be different. The plastic without glass fibre achieves better surface quality, boarder sharpness and filling. Unfilled material has a more homogeneous flow characteristic and better replication quality than glass filled material. Based on the investigations of the critical areas of the moulded specimens, it is concluded that for micro structure replication, material without glass fibres is preferable especially when a smooth surface finish and good replication quality is required.

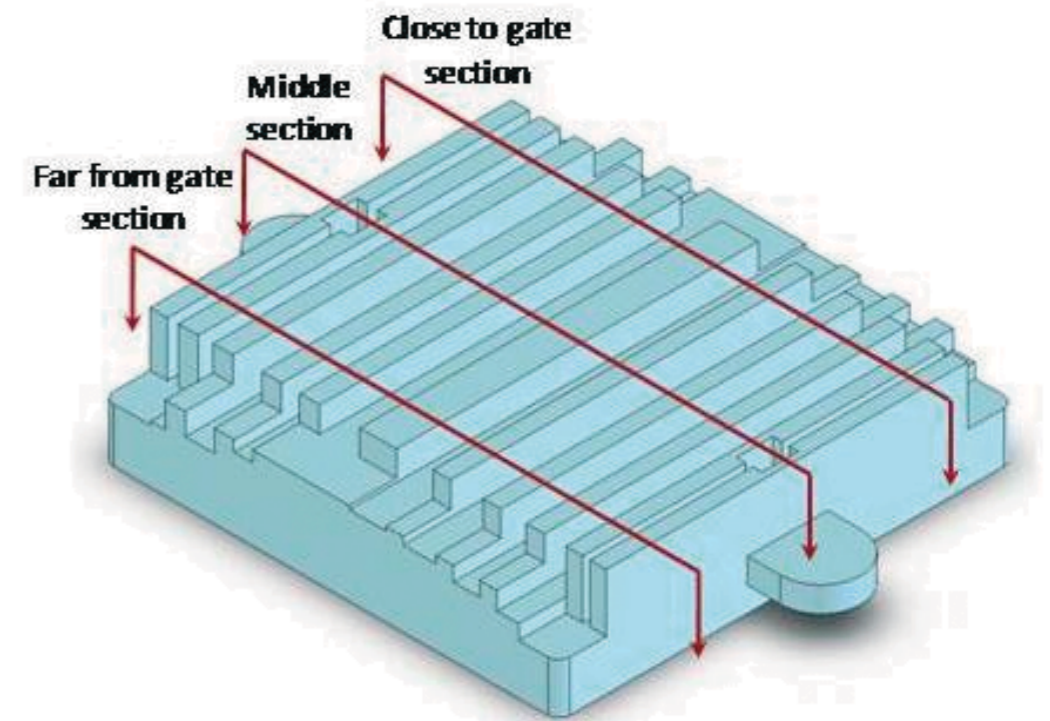

Figure 9: Picture showing different cross sections of the part for the investigation of glass fibredistribution and orientation.



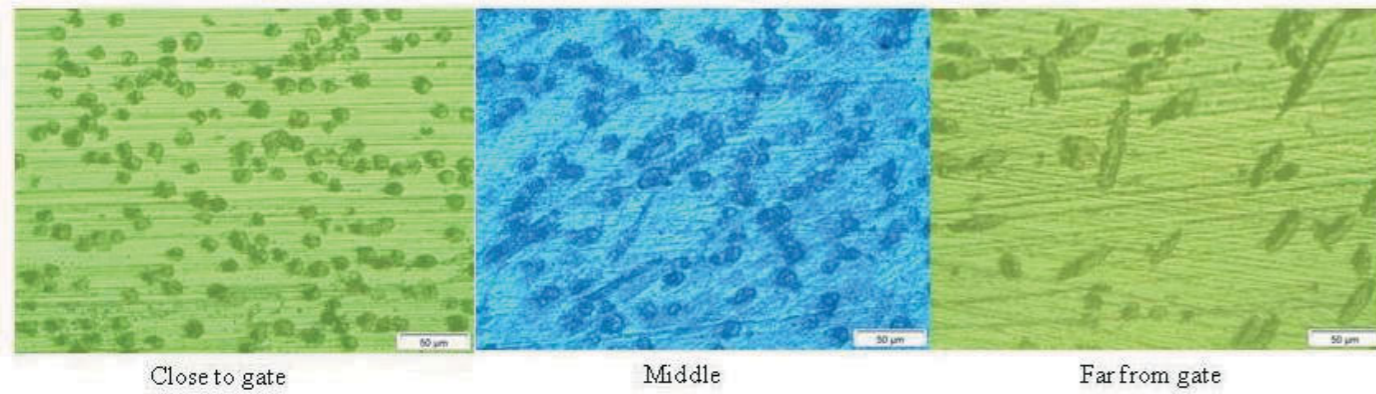
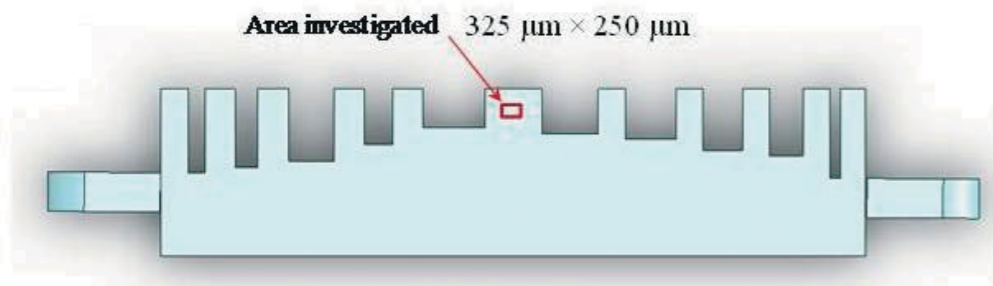

Figure 10: Cross section of the part moulded with glass filled PS (Picture taken under the thick rib and at three different sections based on the distance from the gate location).

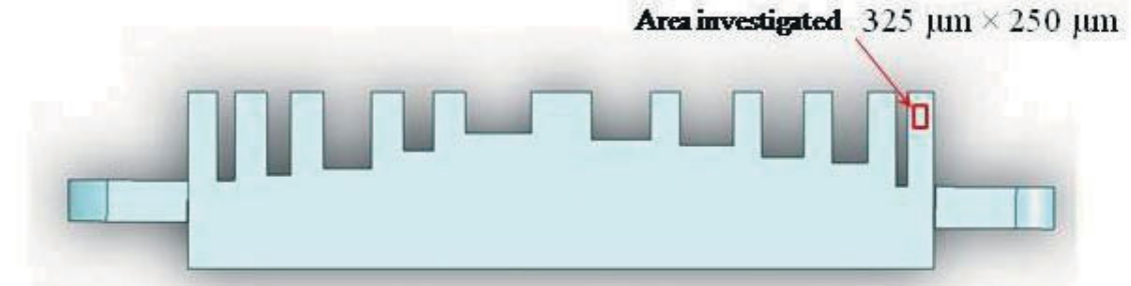

Figure 12: Cross section of glass fibre samples (Picture taken under the thin rib and at three different sections based on the distance from the gate location).

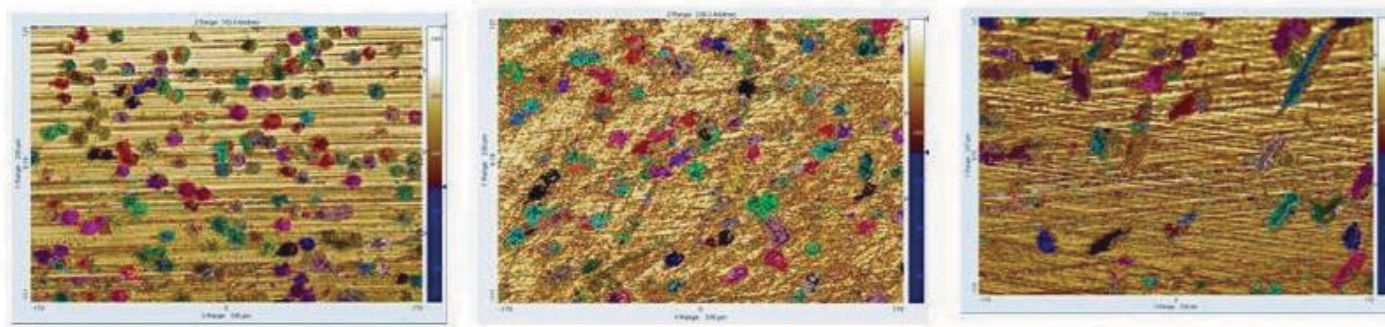

Figure 11: Pictures from glass covered area calculation by SPIP on the three sections under the thick rib.

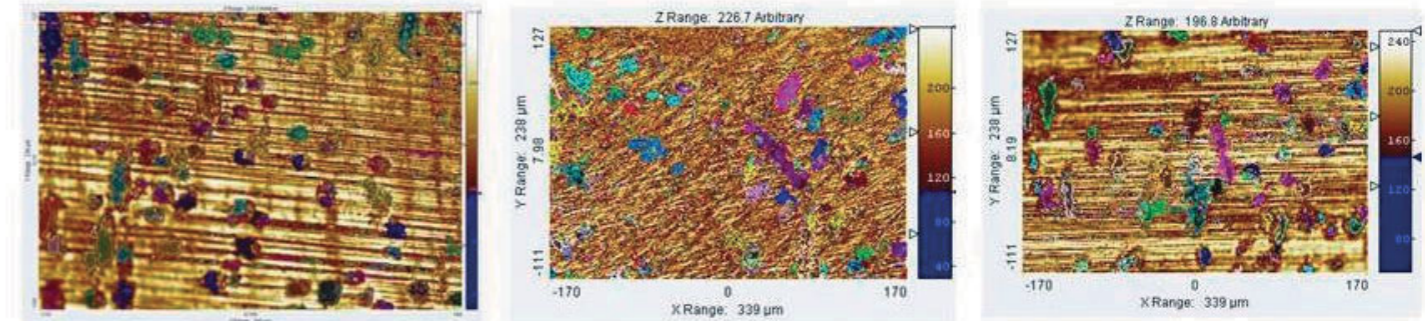

Figure 13: Pictures from glass covered area calculation by SPIP on the three sections under the thin rib.







## References

1. S. I. Shaharuddin; M. S Salit; "A review of the effect of the moulding parameters on the performance of polymeric composite injection moulding", University Putra Malaysia, Department of Mechanical and Manufacturing Engineering, 43400 Serdang, Selangor-MALAYSIA, Published in the Turkish Journal of Engineering and Environmental Science (2006).
2. C. Øllgaard; O. Sundberg, K. Vesth, "Effects of glass fibers on the filling of polymeric thin ribs", Report submitted to Department of Mechanical Engineering, Technical University of Denmark, June 2007.
3. A. Islam, "Two component micro injection moulding for moulded interconnect devices", Ph.D. thesis, Department of Mechanical Engineering, Technical University of Denmark, ISBN no- 978-87-89502-75-5NTEC (2008).
4. J.L. Thomason, "The influence of fiber length and concentration on the properties of glass fiber reinforced polypropylene: 7. Interface strength and fiber strain in injection moulded long fiber PP at high fiber content.  
OI:10.1016/j.compositesa.2006.01.007.  
Composites Part A: Applied Science and Manufacturing.
5. Bernasconi, P. Davoli, A. Basile, A. Filippi, "Effects of fiber orientation on the fatigue behavior of fiber reinforced polyamide-6.  
International Journal of Fatigue. DOI:  
10.1016/j.ijfatigue.2006.04.001.