

Technical University of Denmark



## NOMAGE4 activities 2011, Part II, Supercritical water loop

Vierstraete, Pierre; Van Nieuwenhove, Rudi; Lauritzen, Bent

*Publication date:*  
2012

*Document Version*  
Publisher's PDF, also known as Version of record

[Link back to DTU Orbit](#)

*Citation (APA):*  
Vierstraete, P., Van Nieuwenhove, R., & Lauritzen, B. (2012). NOMAGE4 activities 2011, Part II, Supercritical water loop. Roskilde: NKS. (NKS-255).

## DTU Library

Technical Information Center of Denmark

---

### General rights

Copyright and moral rights for the publications made accessible in the public portal are retained by the authors and/or other copyright owners and it is a condition of accessing publications that users recognise and abide by the legal requirements associated with these rights.

- Users may download and print one copy of any publication from the public portal for the purpose of private study or research.
- You may not further distribute the material or use it for any profit-making activity or commercial gain
- You may freely distribute the URL identifying the publication in the public portal

If you believe that this document breaches copyright please contact us providing details, and we will remove access to the work immediately and investigate your claim.



Nordisk kernesikkerhedsforskning  
Norrænar kjarnöryggisrannsóknir  
Pohjoismainen ydinturvallisuustutkimus  
Nordisk kjernesikkerhedsforskning  
Nordisk kärnsäkerhetsforskning  
Nordic nuclear safety research

NKS-255  
ISBN 978-87-7893-327-0

---

# NOMAGE4 activities 2011, Part II, Supercritical water loop

Pierre Vierstraete (1)  
Rudi Van Nieuwenhove (2)  
Bent Lauritzen (3)

(1) Ecole Nationale Supérieure des mines, France  
(2) Institutt for Energiteknikk, HRP, Norway  
(3) Risoe-DTU, Denmark

January 2012

## Abstract

The supercritical water reactor (SCWR) is one of the six different reactor technologies selected for research and development under the Generation IV program. Several countries have shown interest to this concept but up to now, there exist no in-pile facilities to perform the required material and fuel tests.

Working on this direction, the Halden Reactor Project has started an activity in collaboration with Risoe-DTU (with Mr. Rudi Van Nieuwenhove as the project leader) to study the feasibility of a SCW loop in the Halden Reactor, which is a Heavy Boiling Water Reactor (HBWR). The ultimate goal of the project is to design a loop allowing material and fuel test studies at significant mass flow with in-core instrumentation and chemistry control possibilities.

The present report focusses on the main heat exchanger required for such a loop in the Halden Reactor. The goal of this heat exchanger is to assure a supercritical flow state inside the test section (the core side) and a sub-critical flow state inside the pump section. The objective is to design the heat exchanger in order to optimize the efficiency of the heat transfer and to respect several requirements as the room available inside the reactor hall, the maximal total pressure drop allowed and so on.

## Key words

Supercritical water, counter flow heat exchanger, heat exchange, pressure drop, MathCAD modelling.

NKS-255  
ISBN 978-87-7893-327-0

Electronic report, January 2012

NKS Secretariat  
P.O. Box 49  
DK - 4000 Roskilde, Denmark

Phone +45 4677 4041  
www.nks.org  
e-mail nks@nks.org

# NOMAGE4 activities 2011, Part II

## Feasibility Study for an SCW loop in the Halden reactor

Pierre Vierstraete (1)

Rudi Van Nieuwenhove (2)

Bent Lauritzen (3)

(1) Ecole Nationale Supérieure des mines

(2) Institutt for Energiteknikk

(3) Risø, DTU

## **Abstract**

The supercritical water reactor (SCWR) is one of the six different reactor technologies selected for research and development under Generation IV program. Several countries have shown interest to this concept but up to now, there are no real facilities able to perform the significant material and/or fuel tests required.

Working on this direction, the Halden Reactor Project has started an activity in collaboration with Risoe-DTU (with Dr. Rudi Van Nieuwenhove as the project leader) to study the feasibility of a SCW loop in the Halden Reactor, which is a Heavy Boiling Water Reactor (HBWR). The ultimate goal of the project is to design a loop allowing material and fuel test studies at significant mass flow with in-core instrumentation and chemistry control possibilities.

The present report is focus on the main heat exchanger required for the addition of such a loop in the Halden Reactor. The goal of this heat exchanger is to assure a supercritical flow state inside the test section (the core side) and a subcritical flow state inside the pumps section (the pumps cannot withstand the high temperature of the flow under supercritical conditions). Our mission is to design and take care about the sizing of the heat exchanger in order to optimize the efficiency of the heat transfer and to respect several requirements as the room available inside the reactor hall, the maximal total pressure drop allowed and so on.

## **Key words**

Supercritical water, counter flow heat exchanger, heat exchange, pressure drop, MathCAD modelling.

## Feasibility Study for an SCW loop in the Halden reactor

A feasibility study for an in-pile supercritical water loop in the Halden reactor was previously carried out at the Institute for Energy technology at Halden Norway (by Rudi Van Nieuwenhove). Within the framework of the NOMAGE4 network, the study of the heat exchanger, being the most critical part, has been refined considerably by Pierre Vierstraete of the Ecole Nationale Supérieure des mines (France). The work was performed partly at IFE and partly at Risø DTU (and co-funded by both institutes).

# Feasibility Study for an SCW loop in the Halden reactor

Specific focus on the required Heat Exchanger

November 8th 2010 - May 6th 2011

Supervisors: Rudi Van Nieuwenhove (project leader, IFE)

Erik Nonboel (Risoe-DTU)

Bent Lauritzen (Risoe-DTU)

## **Table of contents**

|   |     |
|---|-----|
| Introduction.....   | p4  |
| Nomenclature.....   | p6  |
| Definitions.....  | p7  |
| I Heat exchanger description.....   | p8  |
| II Supercritical water data.....  | p11 |
| III SCW correlations.....   | p17 |
| IV Temperature profile, equations simplifications and solving methods.....              | p21 |
| V Analysis of the main results.....   | p30 |
| VI Focus on the pressure drop.....  | p38 |
| VII Different practical problems.....   | p45 |
| Conclusion.....   | p55 |
| Acknowledgements.....   | p56 |
| References.....   | p57 |
| Appendix 1: Results for material test condition using the fuel test heat exchanger..... | p58 |



## **Table of figures**

|   |    |
|---|----|
| Figure 1: Schematic drawing of the SCW loop in the Halden reactor .....   | 8  |
| Figure 2: Density of water for several pressures and several temperatures .....   | 14 |
| Figure 3: Heat capacity of water for several pressures and several temperatures .....   | 16 |
| Figure 4: Thermal conductivity of water for several pressures and several temperatures .....                                    | 16 |
| Figure 5: Comparison between linterpCp245, translateCp245 and the heat capacity of water under a pressure of 250 bar .....      | 17 |
| Figure 6: Comparison between the relative error of linterpCp245 and the relative error of translateCp245 .....                  | 18 |
| Figure 7: ratio between measured heat transfer coefficient and predicted heat transfer coefficient (using Dittus-Boelter) ..... | 21 |
| Figure 8: Schematic drawing of the heat exchanger section .....   | 31 |
| Figure 9: Temperature profile for the material test.....  | 34 |
| Figure 10: Temperature profile for the fuel test.....   | 35 |
| Figure 11: Linear friction pressure drop for the material test .....  | 36 |
| Figure 12: Linear friction pressure drop for the fuel test.....   | 36 |
| Figure 13: Heat transfer coefficients for the material test .....   | 37 |
| Figure 14: Heat transfer coefficients for the fuel test.....  | 38 |
| Figure 15: Linear heat transfer for the material test .....   | 39 |
| Figure 16: Linear heat transfer for the fuel test.....  | 39 |
| Figure 17: length vs heater used to heat the cold flow up to 450°C (for the material test).....                                 | 40 |
| Figure 18: Length vs heater used to heat the cold flow up to 450°C (for the fuel test) .....                                    | 40 |
| Figure 19: variation of the heat capacity of water because of the pressure .....  | 43 |
| Figure 20: Comparison between the heat available and the heat needed.....   | 44 |
| Figure 21: pressure drop calculated by SF pressure Drop 7.0 for perforated plate .....  | 47 |
| Figure 22: plan of our material test heat exchanger (using a TIG welding process).....  | 55 |
| Figure 23: Drawing of the graphite seal method .....  | 56 |

## **Introduction**

The supercritical water reactor (SCWR) is one of the six different reactor technologies selected for research and development under Generation IV program. Today, there is still no “generation 4” type of reactor built but an international effort is ongoing to reach this goal (commercial use after 2030). Unlike other “generation IV” type of reactors, SCWR has the advantage to be built on two proven technologies (Light water reactor and supercritical fossil fired fuel) which are already used around the world. So it is not like we start everything from the scratch. Anyway, there is still some research to be performed on this technology mainly because of the high level of radiation in the core which is not present in a fossil fired fuel plant. We need to expand the knowledge in material performance from un-irradiated to irradiated conditions but also the knowledge in water radiolysis from subcritical to supercritical conditions.

Working on this direction, the Halden Reactor Project has started an activity in collaboration with Risoe-DTU (with Mr. Rudi Van Nieuwenhove as the project leader) to study the feasibility of a SCW loop in the Halden Reactor. The operating conditions of this loop should be a pressure of 25 MPa and a maximum wall temperature of 600°C (in-pile section). The loop should allow material and fuel test studies with in-core instrumentation and chemistry control possibilities. In this report, we will focus on the heat exchanger needed for such a loop.

The Halden Reactors is a Heavy Boiling Water Reactor (HBWR) so all the devices are not able to withstand for example a temperature of 500°C. The main idea is to use as much as possible the equipment and infrastructure already present. First, pumps and the water treatment loop cannot work with a flow hotter than 250°C but the temperature of the flow coming out of the in pile section should be at least 450°C in our loop. Thus one needs to cool down this flow. Secondly, the core temperature is not high enough to make the flow reach a temperature above the critical point which is our goal. Thus one needs to heat the flow before it goes inside the in-pile section (the objective is to heat the flow up to 450°C before it goes inside the core). So the idea is to use a counter flow heat exchanger to limit as much as possible the amount of energy provided by the heater (to simplify the construction and reduce the cost of electricity). We will use the heat from the hot flow (the flow downstream the core) to heat as much as possible the cold flow (the flow upstream the core).

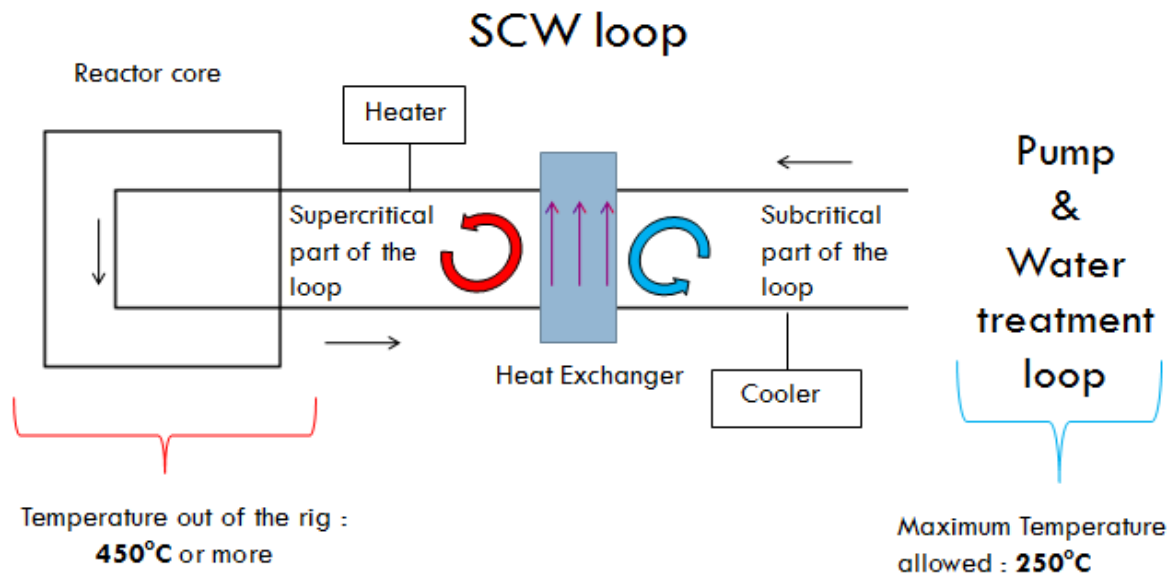

Figure 1: Schematic drawing of the SCW loop in the Halden reactor

To have a better idea about what will happen in practice inside the heat exchanger, a program was written in MathCAD to model such a heat exchanger. The goal was to study the expected efficiency of the heat exchanger depending on several variables such as the length, the total exchange area, and all the geometrical characteristics. Since the reactor hall is already quite full with a lot of equipment (mainly loop systems), one of the requirements for the heat exchanger is that it should not be too large. Another requirement is that the total pressure drop in the loop should not be higher than a few bars (6.6 bars) because of the limitations of the high pressure pump. To reduce the pressure drop as much as possible, the heat exchanger should be located close to the reactor core.

## **Nomenclature**

$\varepsilon$  : Emissivity or relative elongation

$\sigma$  : Stress

$\rho$  : Density

$\lambda$  : Thermal conductivity

$\mu$  : Dynamic viscosity

$C_p$  : Heat capacity

DH : Hydraulic diameter

E : Young's modulus

g : The gravity of Earth

G : Mass flux

Gr : Grashof number

H: Enthalpy

I : Second moment of area

L : Length

mf : Mass flow

Nb (or nb) : Number of small pipes

Nu : Nusselt number

P (or p) : Pressure (a P is also used to represent a power)

Pr : Prandtl number

q : Heat flux or the linear weight of a pipe

R (or r): Radius of the pipes

Re : Reynolds number

T : Temperature

th : Thickness

Tpc : pseudo critical temperature

V : Velocity or the volume

X : the axial position inside the heat exchanger (X=0 is the hot end of the heat exchanger)

subscripts

B : big pipe of our heat exchanger

b : Bulk conditions

c : cold flow conditions

gw : glass wool

h : hot flow conditions

in : conditions of the flow inside the small pipes or reference to the inner radius of a pipe

mat : reference to the used material (so Inconel718)

out : condition of the flow outside the small pipes or reference to the outer radius of a pipe

w : wall conditions

**Definitions**

Efficiency: In this report, when we will talk about the efficiency of an Heat exchanger, that means the ratio between the heat really exchanged inside the heat exchanger (from the hot flow to the cold flow) and the heat needed by the cold flow to reach 450°C (from 250°C).

Pseudo critical temperature: Above the critical point (P = 22.1 MPa and T = 374°C for water), there is for each pressure a temperature where the heat capacity is maximal (under this pressure). We called this temperature the pseudo critical temperature.

Ideal (or perfect) heat exchanger: It is a counter flow heat exchanger with a maximum efficiency (all the heat able to be transferred is actually transferred) and without pressure drop inside (the pressure of the flow remain constant from one end to another).

## **I Heat exchangers description**

As it is explained in the introduction, the goal of our heat exchanger is to exchange heat to the cold flow as much as possible. As we want to heat the cold flow and at the same time cool the hot flow, the idea to use a counter flow heat exchanger seems relevant. We work under a pressure of 250 bars and our temperature range is quite high (about 250°C to 450°C). Furthermore, we work with two supercritical flows (cold flow of water and hot flow of water) which go from a subcritical state (temperature below the pseudo critical temperature) to a supercritical state (temperature above the pseudo critical temperature) inside our heat exchanger.

We have to keep in mind that working in these conditions is really uncommon. For instance, we contacted some companies specialized in building compact heat exchanger (VAHTERUS) but after an attempt, they declared that they didn't have knowledge enough (regarding our conditions) to build a heat exchanger adapted at our need. We have therefore decided to build the needed heat exchanger ourselves. We opted for a geometry which is easy to make: a bundle of straight small pipes inside a bigger pipe. One of the two flows will be inside all the small pipes and will progress in a direction; the other flow will be around all the small pipes and will progress in the other direction. This is our starting point but one can easily understand that the efficiency of our heat exchanger (how much heat is provided to the cold flow compare to the needed heat to make the cold flow reach the temperature of 450°C) will strongly depend on a lot of characteristics of our heat exchanger: length, number of small pipes, thickness of the small pipes, inner diameter of the small pipes, cross section of the outer flow (the flow around the small pipes). We have to choose which material should be the best to build our heat exchanger. We also can put the hot flow inside the small pipes or around the small pipes... In this part, we will present the choices we made for a material test heat exchanger and a fuel test heat exchanger.

First, we have to describe what are the characteristics of a material test and what are the characteristics of a fuel test. Within this report (if not stated otherwise) a material test will be a test where we need a mass flow of 0.1 kg/s and we assume an additional heating inside the core (in pile section) of 5 kW (due to the gamma flux). So for a material test, the temperature of the hot flow at the entrance of the heat exchanger will be 460°C. A fuel test will be a test where we need a mass flow of 0.35 kg/s and we assume an additional heating inside the core of 30 kW. The temperature of the hot flow at the entrance of the heat exchanger will be 468°C.

For the geometrical characteristics, we have to consider several aspects such as total length, total pressure drop, ease of fabrication, etc. Using a heat exchanger longer than nine meters (three units of 3 m in series) doesn't seem realistic. We will consider this length as the maximum possible value. For the size of the small pipes, we have to choose among pipes easily available on the market. We will use pipes with an inner diameter of 2 mm for the material test and pipe with an inner diameter of 3 mm for the fuel test. The thickness of those pipes will be 0.5 mm. Actually, we could choose thinner pipes but as we will see (see the section V "Analysis of the main results", when we discuss about the heat transfer coefficients) this is not really a need for the heat transfer. Furthermore, with a thickness of 0.5 mm, pipes will be easier to find (it is easier to buy tubes with a larger thickness) and most importantly, it allows for a higher safety factor (assuming for instance thinning of the wall

by corrosion over time). To choose the number of small pipes we need, we note [5] that some numbers are better than others. In fact, it is not so easy to put several circles (the bundle of small pipes) in a homogeneous way inside a bigger circle (the big pipe). For the material test we chose a number of 61 small pipes (Look at the part VII.1 to see the distribution) and for the fuel test, we chose a number of 91 small pipes (same distribution than the previous distribution but we add a circle of 30 small pipes at the periphery). Between two small pipes, we will let a space of at least 0.5 mm. Indeed, we need a minimal space to let the outer flow penetrate into the middle of the bundle of the small pipes. To finish, we chose to put the hot flow around the small tubes and the cold flow inside the small tubes. This last choice has been made considering several things. First, whatever the insulation of our heat exchanger (we will use a 10 cm layer of glass wool), it is true that the heat loss will be more important if we put the hot flow around the small pipes. But according to our results, the difference of heat loss should be only 0.0056% of the needed heat exchange between the hot and the cold flow (see the section IV "Temperature profile, equations simplifications and solving methods" and especially the part IV.3 "Heat loss consideration"). Thus, this is totally negligible. At the same time, if we put the hot flow around the small pipes, the efficiency of our heat exchanger will be a little bit better (the needed length to reach a given temperature is between 2 and 8% smaller than for the exact same heat exchanger working with the hot flow inside the small pipes). This is because the outer cross section (cross section around the small pipes) is larger than the inner cross section (cross section inside the small pipes). So the expected heat transfer is lower for the outer flow than for the inner flow. If we put the hot flow outside, the turbulence of the outer flow will be higher (the hot flow is hotter than the cold flow) and so the difference of heat transfer coefficients will be smaller. As the total heat transfer depend on the sum of the reciprocals of the different heat transfers, it is then understandable that the result is better when we put the hot flow around the small pipes and not inside (the two heat transfer coefficients, the one from the inner flow to the pipe inner wall and the one from the outer flow to the pipe outer wall, will be more closer and so the value of the sum of the reciprocals will be higher). Finally, the last argument to put the hot flow outside is related to the thermal expansion. In fact, if the hot flow would be on the inside of the small pipes, these pipes will expand more in length relative to the big pipe and there would be tendency for the small pipes to bow inside the heat exchanger (this could cause problems). If the out flow is outside, the small pipes will be stretched out and that will help to make them remain straight (which is good).

For the material, we chose Inconel 718 mainly because of its very high yield strength (still more than 1180 MPa at 450°C).

For the two kind of tests (material and fuel test) we assume a total pressure drop between the outlet of the cold flow and the inlet of the hot flow (so a total pressure drop because of the heater, the in-pile section and the connecting pipes) of 1 bar. That means that at  $X=0$  (hot end of our heat exchanger), the pressure of the hot flow is 1 bar lower than the pressure of the cold flow (You can see in the section VI "Focus on the pressure drop" why this difference of pressure could be an important factor for our heat exchanger efficiency).

In the following table (table 1), we sum up the main geometrical characteristics of our two kinds of heat exchangers and then we show the main results we got with our MathCAD program. The way we got all these results is detailed in the following sections of this report.

|  | material test | fuel test |
|--|---------------|-----------|
| <b>Geometrical characteristics</b>       |               |           |
| number of units                          | 3             | 3         |
| length of each units (m)                 | 2,8           | 2,8       |
| number of small pipes                    | 61            | 91        |
| inner diameter of small pipes (mm)       | 2             | 3         |
| thicness of small pipes (mm)             | 0,5           | 0,5       |
| inner diameter of the big pipe (mm)      | 30,3          | 52        |
| <b>Results gotten using our program</b>  |               |           |
| outlet temperature of the cold flow (°C) | 430           | 420       |
| outlet temperature of the hot flow (°C)  | 285           | 305       |
| friction pressure drop cold flow (bar)   | 0,448         | 0,27      |
| friction pressure drop hot flow (bar)    | 0,339         | 0,203     |
| total friction pressure drop (bar)       | 0,787         | 0,473     |
| needed heater (kW)                       | 11            | 63        |
| needed cooler (kW)                       | 17            | 94        |
| heat exchanger efficiency                | 0,94          | 0,90      |

Table 1: Main characteristics of our two heat exchangers



## II Supercritical water data

The main goal of our work is to model the heat transfer from the hot flow to the cold flow in order to get important results (as the needed length of the heat exchanger for example) depending on some parameters (mass flow, number of pipes, cross section...). The accuracy of the thermodynamic data of water in our pressure and temperature range (250/450°C and about 250 bar) is of course critical since all results will depend directly on these data.

The required data for water are: the specific enthalpy, the specific heat capacity, the thermal conductivity, the dynamic viscosity and the density. All these functions depend on the pressure and the temperature.

All our data are from the institute of standards and technology (NIST) website and thus, precision of our program depends directly on the precision of this data. To use these data in our Mathcad files, we made a linear interpolation of data from NIST. First, we fixed the pressure and defined thermodynamic water proprieties only depending on the temperature. Here (figure 2) is an example of what we get for the density at several pressures (250, 249, 248, 247, 246, 245, 244, 240 bar) in our working temperature range (from 250°C to 450°C):

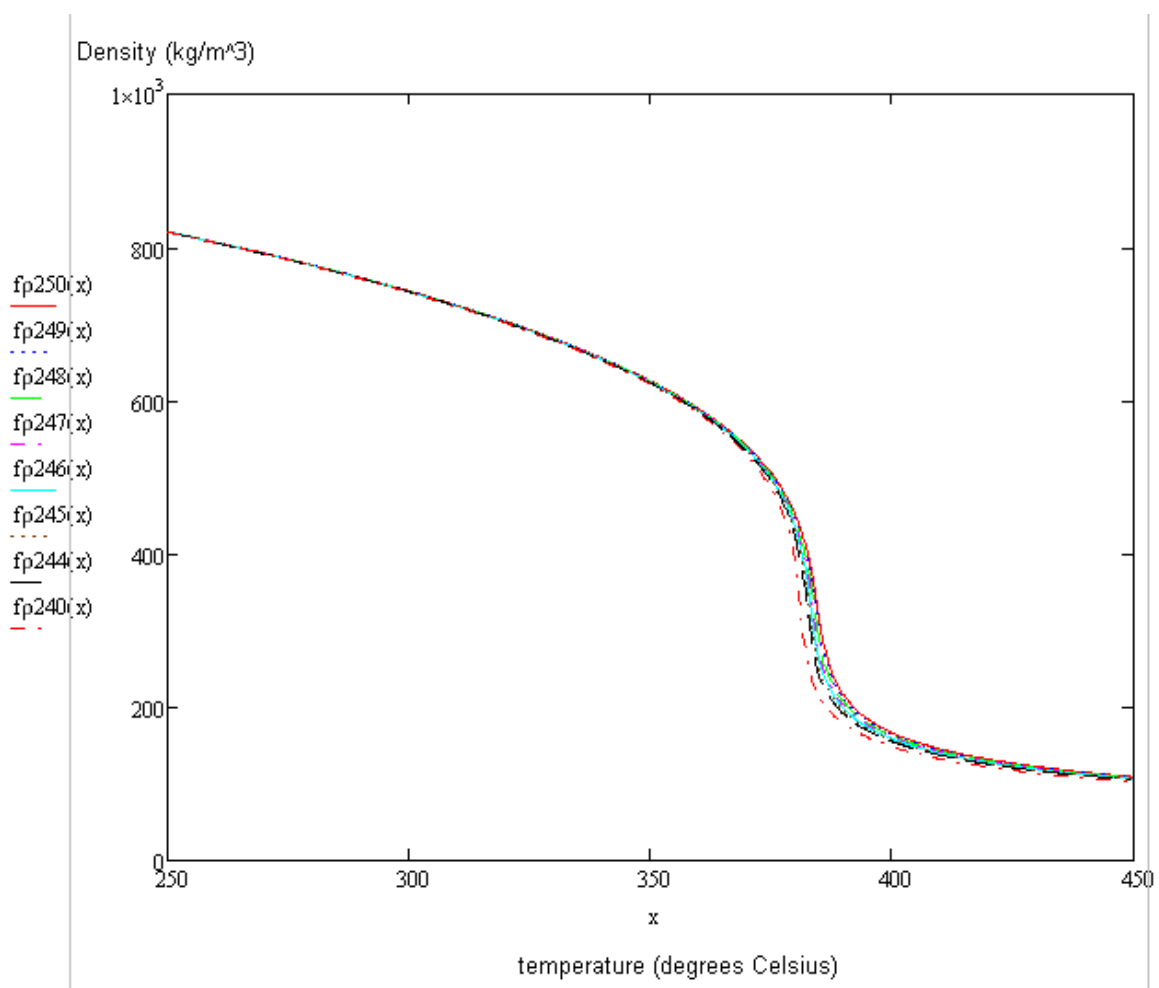

Figure 2: Density of water for several pressures and several temperatures

### Expected precision.

We need to have an idea of the precision obtained by using linear interpolation of the data from NIST. What we know is that the more we used different points, the better should be the accuracy. But how could we get a quantitative estimation?

To do that, we noticed that the specific heat seems to have the higher second derivative near the critical point. Thus, we decided to assume that this function was the one with the poorest accuracy because of the linear interpolation (we used the same number of point for each function). Then, we know that for every T1 and T2 (two different temperatures) and at a given pressure P one should have:

$$H(T2, P) - H(T1, P) = \int_{T1}^{T2} C_p(x, P) dx$$

Where H is the specific enthalpy and Cp the specific heat capacity.

So, for each pressure (250, 249, 248, 247, 246, 245, 244, 240 bar) we added points until the relative difference of these two functions was everywhere smaller than 0.003. Once that is done, we considered that, at a given pressure, all our data for water thermodynamic proprieties had an accuracy of 3 promille.

### Data depending of the temperature and the pressure.

Because of the pressure drop inside the heat exchanger, it would not be correct to assume a constant pressure for the hot flow and another constant pressure for the cold flow. The pressure will change continuously from one end to another of the heat exchanger. So, it seems interesting to have the possibility to get water proprieties for any temperature between 250 and 450 °C but also for any pressure from 240 bar to 250 bar (In fact, we will not work with pressure lower than 244 bar because a 6 bar pressure drop is about the maximum allowed by the kind of pump we want to use).

For the specific enthalpy, the dynamic viscosity and the density, it seemed to be good enough to do a second linear interpolation (but with the pressure this time). But for the specific heat capacity and for the thermal conductivity, the shape of curves near the pseudo critical point seems to be inappropriate for this simple method:

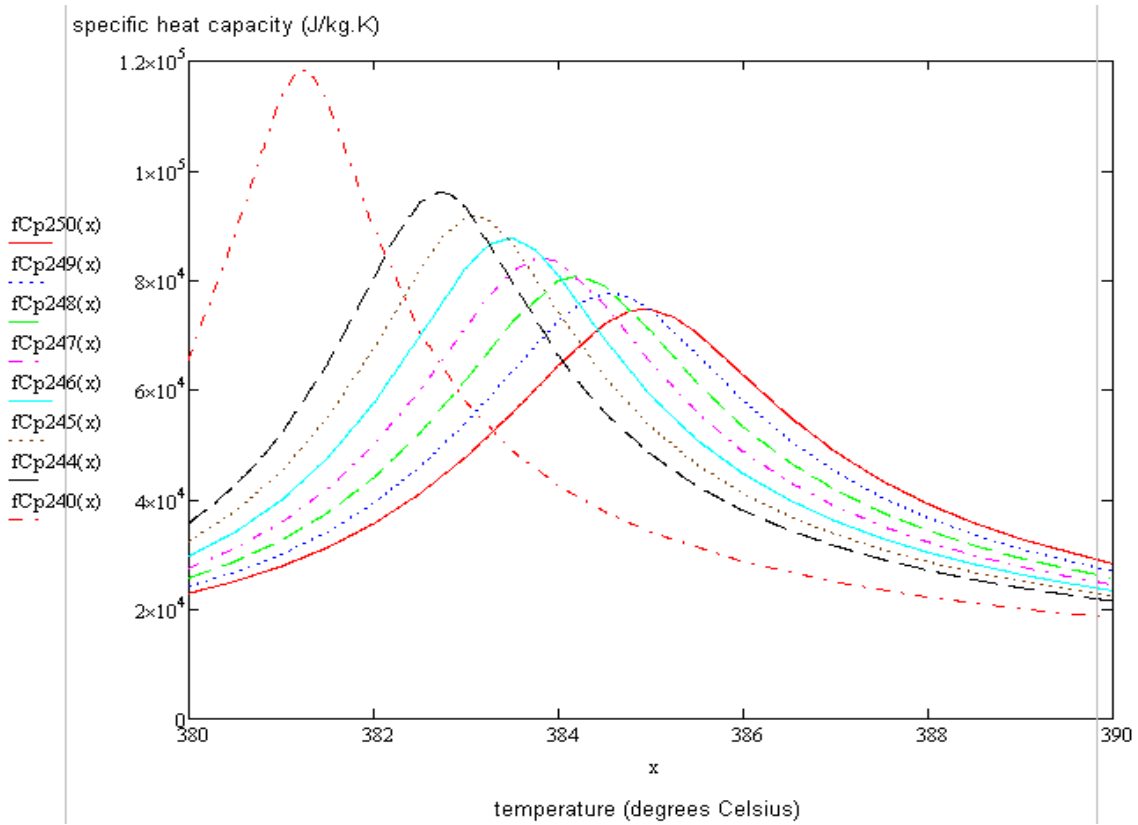

Figure 3: Heat capacity of water for several pressures and several temperatures

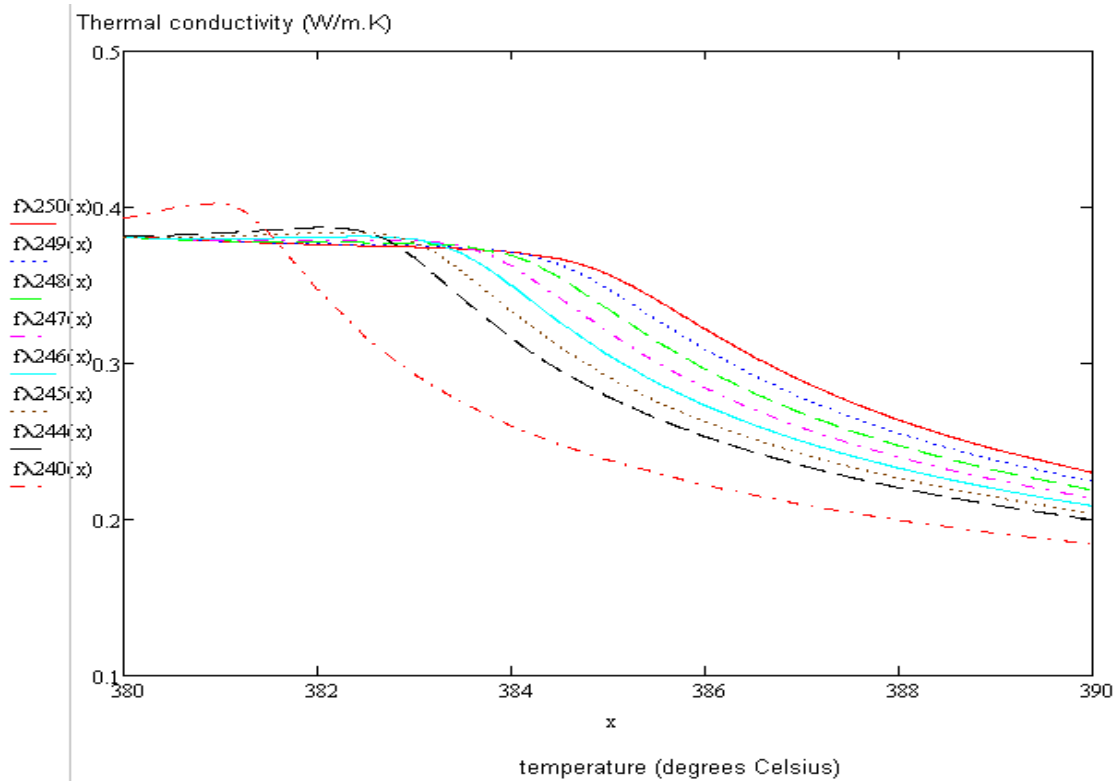

Figure 4: Thermal conductivity of water for several pressures and several temperatures

Actually, it seems easy to remedy the problem. We will detail this for the specific heat capacity.

For the specific heat capacity:

Instead of performing a linear interpolation of functions  $C_p(x)$ , one should simply do a linear interpolation with translations of specific heat capacity functions. For example, if we used the known specific heat capacity at 244 bar and 246 bar to predict the heat capacity at 245 bar with a standard linear interpolation, the formula will be:

$$\text{linterpCp245}(x) = \frac{f_{Cp246}(x) + f_{Cp244}(x)}{2}$$

Now, if we note  $T_{pc246}$  and  $T_{pc244}$  the pseudo critical temperature of water at respecting 246 and 244 bar, we can define another function:

$$\text{translateCp245}(x) = \frac{f_{Cp246}\left(x + \frac{T_{pc246} - T_{pc244}}{2}\right) + f_{Cp244}\left(x - \frac{T_{pc246} - T_{pc244}}{2}\right)}{2}$$

Now, we can compare these two functions with the heat capacity function,  $f_{Cp245}(x)$ , we got using directly the data of NIST (by a linear interpolation at the constant pressure of 245 bars):

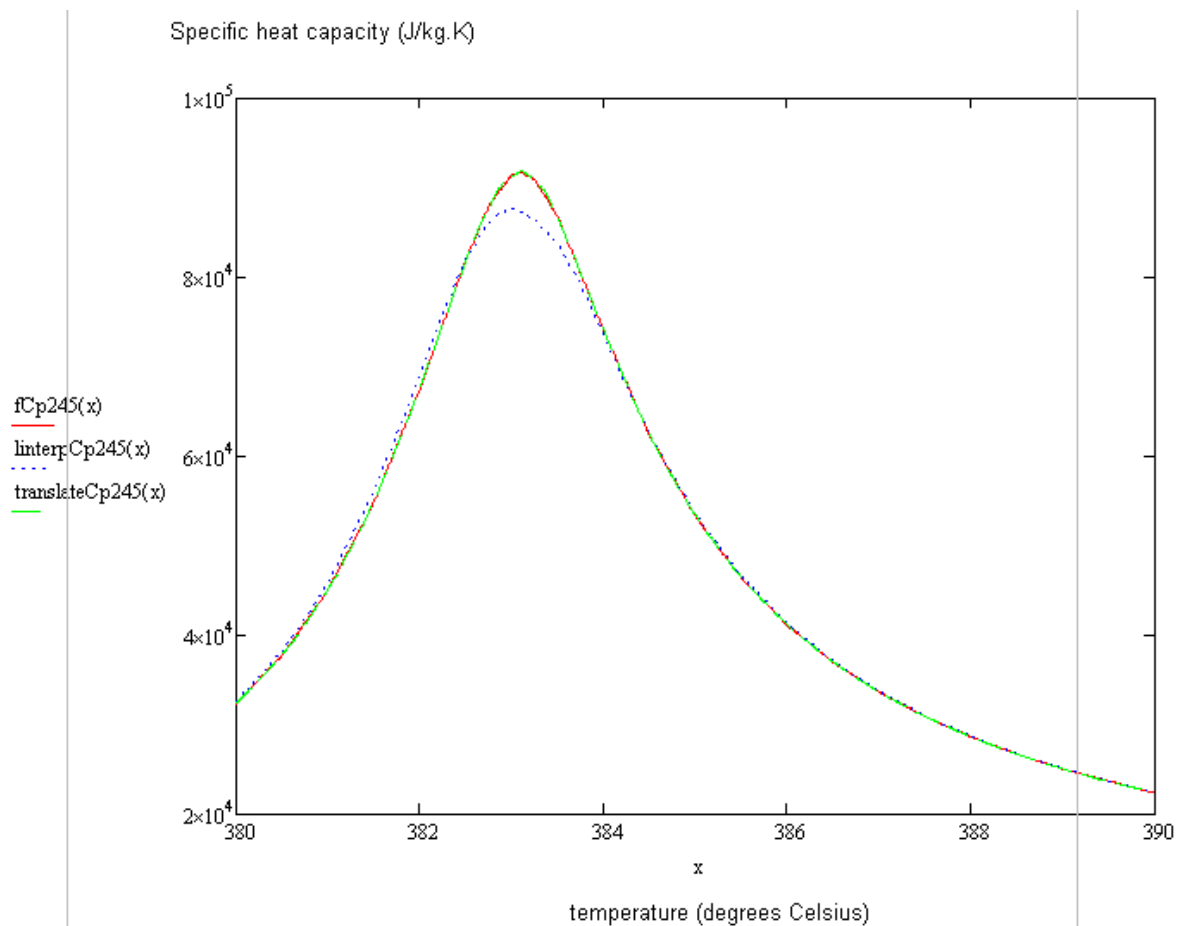

Figure 5: Comparison between  $\text{linterpCp245}$ ,  $\text{translateCp245}$  and the heat capacity of water under a pressure of 250 bar

So it seems clear that translateCp245 is a better approximation of fCp245 than linterpCp245 (especially near the pseudo critical temperature). To be totally certain of that, we can look at the relative difference with fCp245(x). We note:

$$\text{errorlin}(x) = \frac{f_{\text{Cp245}}(x) - \text{linterpCp245}(x)}{f_{\text{Cp245}}(x)}$$

$$\text{errortranslate}(x) = \frac{f_{\text{Cp245}}(x) - \text{translateCp245}(x)}{f_{\text{Cp245}}(x)}$$

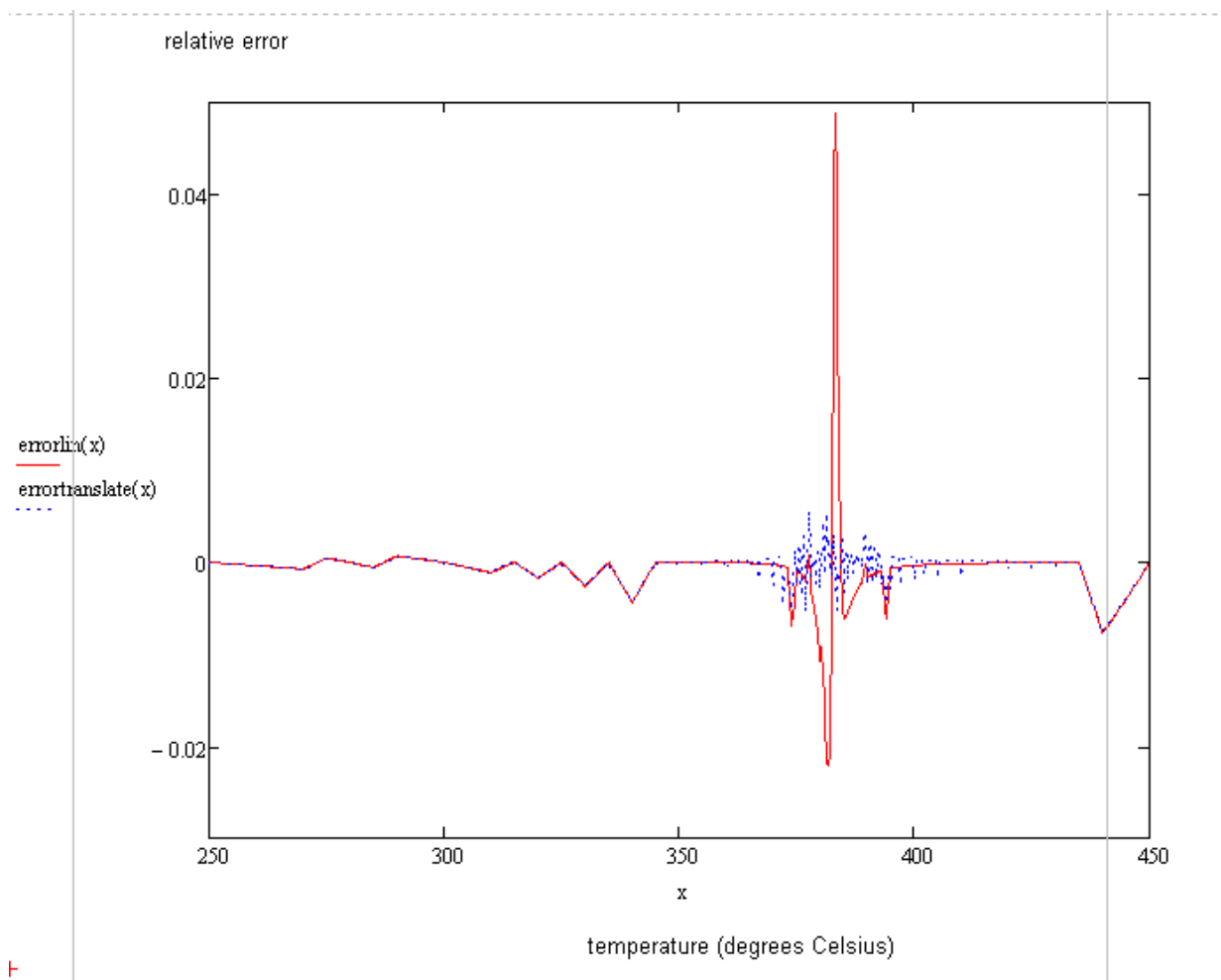

Figure 6: Comparison between the relative error of linterpCp245 and the relative error of translateCp245

So as we can see, the relative error with a standard linear interpolation is, in this specific case, close to 5% near the pseudo critical temperature. The function translateCp245 shows better result with a relative error everywhere smaller than 0,8%. Thus, we will use this kind of interpolation for every pressure between 240 and 250 bar (and of course, each time, we will use the two nearest functions we got according to the pressure. For example, if we need fCp247,2(x), we will use fCp247(x) and fCp248(x). If we need fCp245,6(x), we will use fCp245(x) and fCp246(x)).

For the thermal conductivity, we do exactly the same thing and actually, the precision is even better.

Conclusion about the data used

Finally, it seems realistic to consider that for any temperature  $x$  between 250°C and 450°C, for any pressure  $y$  between 244 bar and 250 bar, for any function  $f$  among the specific enthalpy, the specific heat capacity, the thermal conductivity, the dynamic viscosity and the density we have:

$$f(x, y) \text{ Mathcad program} = f(x, y) \text{ NIST} \cdot (1 + \epsilon)$$

With  $-0.01 \leq \epsilon \leq 0.01$

In the following table, you can see some results about the relative error (between the program data and the data from NIST) calculated for random couples of temperature and pressure:

| temperature (°C) | pressure (bar) | relative error    |                        |                      |                   |         |
|------------------|----------------|-------------------|------------------------|----------------------|-------------------|---------|
|                  |                | specific enthalpy | specific heat capacity | thermal conductivity | dynamic viscosity | density |
| 273              | 248,6          | 0,016%            | 0,066%                 | 0,040%               | 0,032%            | 0,021%  |
| 329              | 245,2          | 0,010%            | 0,082%                 | 0,011%               | 0,008%            | 0,017%  |
| 371              | 246,7          | 0,015%            | 0,341%                 | 0,015%               | 0,033%            | 0,039%  |
| 381,16           | 247,8          | 0,019%            | 0,443%                 | 0,011%               | 0,046%            | 0,058%  |
| 388,3            | 245,6          | 0,008%            | 0,046%                 | 0,013%               | 0,024%            | 0,043%  |
| 391,5            | 248,4          | 0,013%            | 0,246%                 | 0,075%               | 0,034%            | 0,069%  |
| 408              | 249,5          | 0,033%            | <b>0,702%</b>          | 0,257%               | 0,057%            | 0,180%  |
| 444              | 244,3          | 0,038%            | 0,660%                 | 0,267%               | 0,036%            | 0,225%  |

Table 2: relative error for random couples

According to this table, the poorest accuracy seems to be for the specific heat capacity. Anyway, the relative error seems to stay below 1% (in the table, the maximum is 0,7%). Of course, this table does not prove that the relative error will be everywhere smaller than 1% but it let us think that this assumption is not unrealistic.

### **III SCW correlations**

In order to be able to estimate with the greatest possible precision what will happen inside our counter flow heat exchanger, it seems essential to find reliable correlations to predict the heat transfer coefficient and the expected friction pressure drop. Several studies of supercritical fluids have been performed since the 50's and a lot of results are available in the open literature. In this part, we will sum up the main information we found.

#### **III.1 Heat transfer coefficient**

A lot of experimental works and/or development of predictive methods have been performed to study heat transfer under supercritical pressure. The results (especially the numerical correlation proposed by different authors) diverge sometimes depending on some parameters range but there are anyway some general results.

##### *General results*

All correlations we found give the same result regarding the hydraulic diameter of the tube: the heat transfer coefficient increases when the tube diameter decreases ([1], [5]).

All studies seem to show that standard correlations as the Dittus-Boelter correlation :

$$Nu = 0.023 \cdot Re^{0.8} \cdot Pr^{\frac{1}{4}}$$

fit quite well to the experimental data (gotten for turbulent flow in a circular tube) as long as the bulk temperature remains distant from the pseudo critical temperature ([1], [5]).

Close to the pseudo critical temperature, at a given mass flux, the real heat transfer coefficient (according to the experimental data) deviates from the Dittus-Boelter prediction. At a low heat flux, the heat transfer coefficient is higher than expected (using the Dittus-Boelter correlation) and at high heat flux, the heat transfer coefficient is lower. This last case is called "heat transfer deterioration" ([1], [5], [6]).

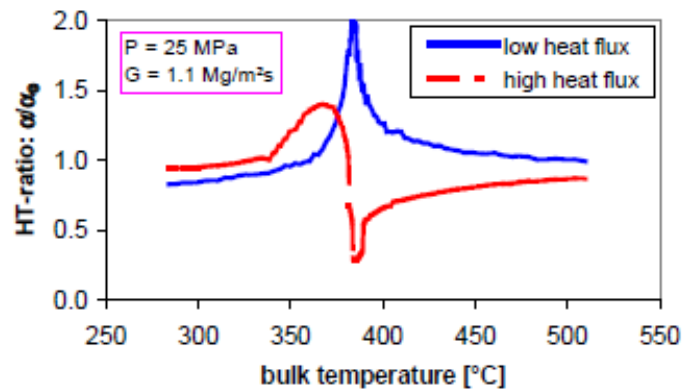

Figure 7: ratio between measured heat transfer coefficient and predicted heat transfer coefficient (using Dittus-Boelter)

Where  $\alpha$  is the real heat transfer coefficient and  $\alpha_0$  is the calculated heat transfer coefficient using Dittus-Boelter correlation (the curves are from [1]).

#### Focus on the heat transfer deterioration

The occurrence of heat transfer deterioration could be a problem for our heat exchanger, however all the articles we found seem to agree that heat transfer deterioration can only happen when:

- The temperature of the flow is lower than the pseudo critical temperature but the wall temperature is higher than the pseudo critical temperature ([1], [3], [5])
- The heat flux is above a limit heat flux and this heat flux limit depends on the mass flux ([1], [2], [5], [6]).

To predict this “heat flux limit” depending on the mass flux, several correlations exist but the correlation of Yamagata seems to be reliable and the most use ([1], [2]):

$$q = 200 \cdot G^{1.2}$$

Where  $q$  is the heat flux ( $W/m^2$ ) and  $G$  the mass flux ( $kg/m^2.s$ ). The limit heat flux is defined as the smallest heat flux for which the measured heat transfer coefficient is lower than 30% of the heat transfer coefficient for a heat flux equal to zero (or very close to zero).

It is clear that we should avoid the heat transfer deterioration problem in our heat exchanger. Indeed, the maximum heat flux for the location where  $T_b < T_{pc} < T_w$  inside our heat exchanger (for several different geometries) is always around  $50 \text{ kW}/m^2$  and the mass flux is always around  $500 \text{ kg}/m^2.s$ . According to the Yamagata correlation, the heat flux limit is  $367 \text{ kW}/m^2$ , which is much higher than our maximum heat flux. **So heat transfer deterioration shouldn't occur in our heat exchanger.**

#### The available correlations

Searching through the open literature, one can easily find different correlations to estimate the heat transfer of a supercritical fluid ([1] is a good example). But we have to keep in mind that all these correlations have been made for a certain parameter range (mass flux, heat flux, pressure, diameter



of the tube). Finding a correlation valid for our own parameters range is already more difficult. Here is a comparison between our parameters range (at least parameters range which seem realistic for our heat exchanger) and those for different correlations we found:

|                                 | us      | Dickson at al. | Domin    | Bishop   | Swenson  | Ackermann | Yamagata | Griem    |
|---------------------------------|---------|----------------|----------|----------|----------|-----------|----------|----------|
| pressure (bar)                  | 250     | 250-321        | 220-260  | 226-275  | 227-413  | 227-441   | 226-294  | 220-270  |
| mass flux (kg/m <sup>2</sup> s) | 340-600 | 2100-3400      | 600-5100 | 680-3600 | 200-2000 | 135-2170  | 310-1830 | 300-2500 |
| heat flux (kW/m <sup>2</sup> )  | 20-160  | 880-1800       | 580-4500 | 310-3500 | 200-2000 | 120-170   | 116-930  | 200-700  |
| hydraulic diameter (mm)         | 2-3     | 7,6            | 2,0-4,0  | 2,5-5,1  | 9,4      | 9,4-24,4  | 7,5-10   | 10-24    |

Table 3: Parameters ranges

As one can see, one of our main problems is that a lot of correlations have been made to predict the heat transfer between the water flow and, for instance, a fuel rod (so a heat transfer with a high heat flux), but that is not really our case. We try to model the heat exchange between two flows of water under super critical pressure. The heat exchanger is a counter flow heat exchanger so the difference of temperature between the hot and the cold flow at any location inside the heat exchanger shouldn't be very high. Therefore, the heat flux shouldn't be very high either.

Luckily, studies have been performed during the last decade to expand the knowledge of heat transfer under supercritical pressure for low heat flux and inside pipe with small inner diameter ([5]) which is exactly our case. According to the articles we found ([5], [4]), the Watts and Chou correlation should be the better one to predict the heat transfer coefficient for the heating of the flow inside our heat exchanger:

$$Nu = 0.021 * Re^{0.8} * Pr_m^{0.55} * \left(\frac{\rho_w}{\rho_b}\right)^{0.25} * f\left(\frac{Gr_m}{Re^{2.7} * Pr_m^{0.5}}\right)$$

$$\text{With: } f\left(\frac{Gr_m}{Re^{2.7} * Pr_m^{0.5}}\right) = \left(1 - 3000 \frac{Gr_m}{Re^{2.7} * Pr_m^{0.5}}\right)^0 .295 \quad \text{if } \frac{Gr_m}{Re^{2.7} * Pr_m^{0.5}} \leq 1.0 * 10^{-4}$$

$$f\left(\frac{Gr_m}{Re^{2.7} * Pr_m^{0.5}}\right) = \left(7000 \frac{Gr_m}{Re^{2.7} * Pr_m^{0.5}}\right)^0 .295 \quad \text{if } \frac{Gr_m}{Re^{2.7} * Pr_m^{0.5}} > 1.0 * 10^{-4}$$

Where, using b for the bulk temperature and w for the wall temperature:

$$\rho_m = \frac{1}{w - b} * \int_b^w \rho_z dz$$

$$Gr_m = \rho_b * (\rho_b - \rho_w) * 9.81 * \frac{DH^3}{\mu_b^2}$$

$$\text{Pr}_{\text{m}} = \frac{(H_w - H_b) * \mu_b}{(w - x) * \lambda_b}$$

### Important remarks

The Watts and Chou correlation show good results compared to experimental data for tube with small diameter according to [5] but the smaller inner diameter tube tested was 3.9 mm. In our heat exchanger, the inner diameter of our small pipes should be a little bit smaller (2 or 3 mm).

The minimum mass flux tested (according to what we found in the open literature) with Watts and Chou was 400 kg/m<sup>2</sup>.s ([5]). If we are led to work in these conditions, we must take account of that.

Most studies made about heat transfer for supercritical fluid have been performed inside circular pipe. We have never found any results for a fluid flowing around a bundle of pipe. Note anyway that some studies let us think that the shape (circular or annulus) doesn't affect strongly the value of the heat transfer coefficient ([4]).

All the correlations we found have been made assuming a constant heat flux (all along the pipe) but inside our heat exchanger, there is no reason for the heat flux to remain constant (and we will see that it is not constant).

Finally (the most important problem for our study), all the correlations we found in the open literature were derived to predict the heat transfer coefficient for the heating of the flow but never for the cooling of the flow. That will be problematic to model the heat exchange between the hot flow and wall of the pipes.

### III.2 Friction pressure drop correlation

Generally, to calculate the friction pressure drop, one has to calculate:

$$\Delta p = f * \frac{L}{DH} * \frac{V^2}{2 * g}$$

Where f is a dimensionless coefficient. Of course, the difficulty is to get a good estimation of f.

Several correlations are available in the open literature to predict the coefficient f for a flow under supercritical pressure. One has been proposed by the former Soviet scientists (found in [1]):

$$f = \frac{1}{(1.82 * \log(\frac{Re}{2}))^2} * \left(\frac{\rho_w}{\rho_b}\right)^{0.4}$$

Another one has been proposed by Itaya and has been tested especially for tube with small inner diameter ([5]):

$$f = 0. \frac{314}{0.7 - 1.65 * \log(Re) + (\log(Re))^2} * \left(\frac{\mu_w}{\mu_b}\right)^{0.72}$$

According to [5], this last correlation predicts the friction factor with a precision of more or less 15 %.

Using one or the other of these correlations in our program doesn't change significantly our results. The average deviation from one to the other is less than 1 %.

Note that if we use the standard Colebrook correlation, the difference with the correlation especially made for supercritical conditions can be as large as 70 %. The Colebrook correlation seems to overpredict hugely the value of  $f$  (compared to the two other correlations and considering a pipe roughness of 0.02 mm).

## IV Temperature profile, equations simplifications and solving methods

The temperature profile is really the heart of our model. Once we will have this result, we will know the required length of the heat exchanger (depending of all the geometrical characteristics chosen) to reach a certain temperature but we will also be able to calculate the velocity profile, the friction pressure drop profile, the linear heat exchange and so on. To determine the temperature profile, we have to use the only flow proprieties we know (temperature and pressure of the hot and the cold flow at one end of the heat exchanger) and the first law of thermodynamics.

### IV.1 First law of thermodynamics

Just writing the first law of thermodynamics using the enthalpy (H) instead of the internal energy, one gets:

$$\Delta H + \Delta E_k + \Delta E_p = Q + \int V dp$$

Where H is the enthalpy,  $E_k$  the Kinetic energy,  $E_p$  the potential energy (due to gravity), Q the heat exchange and  $\int V dp$  which represents the work needed to make the fluid pass through the considered system.

This equation has to be respect by the cold flow and the hot flow passing through the heat exchanger.

Solving such an equation could be difficult but as we can already get some rough estimation of several terms, we will be able to make some simplifications.

First, we know that our goal is to increase the temperature of the cold flow from 250°C to 450°C and under a pressure of 250 bar:

$$\Delta H = 1864 \frac{\text{kJ}}{\text{kg}}$$

We know that our mass flux should be smaller than 600 kg/m<sup>2</sup> so the variation of kinetic energy depends only on the variation of the water density (from 250°C to 450°C):

$$\Delta E_k = 0.015 \frac{\text{kJ}}{\text{kg}}$$

Our heat exchanger is supposed to be in the horizontal position, anyway, even assuming an elevation difference of 10 meter (which is a large overestimation), we get:

$$\Delta E_p = 0.098 \frac{\text{kJ}}{\text{kg}}$$

Finally, we know we need to keep the pressure drop in the entire loop smaller than 6.6 bar (because of our pump limitation). Even assuming that this value is reached in each flow just because of the friction pressure drop inside the heat exchanger and even if we assume that the temperature of both flows is everywhere 450°C inside our heat exchanger (which will lead to a really huge over-estimation for the last term) we get:

$$\int V dp = 6.055 \frac{\text{kJ}}{\text{kg}}$$

Compared to  $\Delta H$ , the other terms are very small. The largest one is  $\int V dp$  but it is just about 0.3% of  $\Delta H$ . Because of that, we decided to neglect those terms and we just keep:

$$\Delta H = Q$$

#### IV.2 Solving of the equation

To solve the equation from the first law of thermodynamics for the hot and the cold flow, we assume that we are in a steady state (values of properties don't depend on the time) and that all the variables only depend on the axial position but not on the radial position inside the heat exchanger. So these two assumptions lead us to consider that everything (temperature, velocity...) only depends on one variable  $X$  which is the axial position inside the heat exchanger. Under these assumptions, the equation  $\Delta H = Q$  leads to (the  $x$  axis is oriented in the same direction as the hot flow):

$$\begin{cases} -A_h \cdot \lambda(T_h; P_h) \cdot \frac{d^2 T_h}{dx^2} + mf \cdot C_p(T_h; P_h) \cdot \frac{dT_h}{dx} + 2\pi \cdot nb \cdot H_{h \rightarrow c} \cdot (T_h - T_c) = 0 \\ -A_c \cdot \lambda(T_c; P_c) \cdot \frac{d^2 T_c}{dx^2} - mf \cdot C_p(T_c; P_c) \cdot \frac{dT_c}{dx} + 2\pi \cdot nb \cdot H_{h \rightarrow c} \cdot (T_c - T_h) = 0 \end{cases}$$

Where:

$$H_{h \rightarrow c} = \left[ \frac{1}{R_{in} \cdot h_{in}} + \ln\left(\frac{R_{out}}{R_{in}}\right) + \frac{1}{R_{out} \cdot h_{out}} \right]^{-1}$$

$h_{in}$  is the heat transfer coefficient between the cold flow and the pipe inner wall and  $h_{out}$  is the heat transfer coefficient between the hot flow and the pipe outer wall.

As might be expected, we get a system of coupled differential equations. The first term of each equation (the second derivative) represents the heat transfer due to the axial thermal conduction inside both flows (the upstream flow and the downstream flow are not at the same temperature). The second term (the first derivative) represents the change of enthalpy for an elementary part of the fluid advancing inside the heat exchanger (Since  $T$  depends on  $X$ , an advancement of the fluids

leads to a change in enthalpy). Note that the “+” sign for the hot flow and the “-“ sign for the cold flow is due to the fact that our heat exchanger is a counter flow type (so the cold flow and the hot flow don’t go in the same direction). The last term represents the heat exchange between the hot and the cold flow through the pipes wall.

To simplify the expressions, we will note:

$$a = A_h * \lambda(T_h; P_h)$$

$$b = mf * Cp(T_h; P_h)$$

$$c = 2\pi * nb * H_{h-c}$$

$$\alpha = A_c * \lambda(T_c; P_c)$$

$$\beta = mf * Cp(T_c; P_c)$$

a, b, c,  $\alpha$  and  $\beta$  are function of  $T_h$ ,  $T_c$ ,  $P_h$  and  $P_c$ . Finding an analytical solution of the equations, shown below, is therefore not so easy:

$$-a * \frac{d^2 T_h}{dx^2} + b * \frac{dT_h}{dx} + c * (T_h - T_c) = 0$$

$$-\alpha * \frac{d^2 T_c}{dx^2} - \beta * \frac{dT_c}{dx} + c * (T_c - T_h) = 0$$

However a, b, c,  $\alpha$  and  $\beta$  depend on  $T_h$ ,  $T_c$ ,  $P_h$  and  $P_c$  but  $T_h$ ,  $T_c$ ,  $P_h$  and  $P_c$  only depend on X (the axial position inside the heat exchanger) because of our assumptions. So for a very short length (between X and X+ $\epsilon$ ) one can consider a, b, c,  $\alpha$  or  $\beta$  to be constant. In our program, we work with  $\epsilon = 1$  mm but of course we can change this value if we are not satisfied by the result.

So for each millimeter, we have to solve these simultaneous equations.

The first method is to consider also  $T_c$  constant when we calculate a solution for  $T_h$  and to consider  $T_h$  constant when we calculate a solution for  $T_c$ . With all these assumptions, an analytical solution can now be found (solution 1):

$$T_h(x) = (T_h(0) - T_c(0)) * e^{k_1 x} + T_c(0)$$

$$T_c(x) = (T_c(0) - T_h(0)) * e^{k_2 x} + T_h(0)$$

With:  $r_1 = \frac{-b + \sqrt{b^2 + 4ac}}{-2a}$  and  $r_2 = \frac{\beta - \sqrt{\beta^2 + 4\alpha c}}{-2\alpha}$

The second method is based on the fact that in our case, the heat transfer due to the axial thermal conduction is very low. The maximum ratio  $\lambda/C_p$  (between 250°C and 450°C) is obtained for the low temperature but it is never above 1.4E-4 kg/m.s. So, even assuming a mass flux of 340 kg/s.m<sup>2</sup> (thus a small value), we have:

$$\frac{a}{b} \text{ and } \frac{\alpha}{\beta} \leq 4.12 * 10^{-7} \text{ m}$$

So it seems acceptable to neglect the second derivative term in our equation:

$$\left\{ \begin{array}{l} b * \frac{dT_h}{dx} + c * (T_h - T_c) = 0 \\ -\beta * \frac{dT_c}{dx} + c * (T_c - T_h) = 0 \end{array} \right.$$

If we consider one more time  $T_c$  to be constant when calculating  $T_h$  and  $T_h$  to be constant when calculating  $T_c$  we get (solution 2):

$$T_h(x) = (T_h(0) - T_c(0)) * e^{rx} + T_c(0)$$

$$T_c(x) = (T_c(0) - T_h(0)) * e^{rx} + T_h(0)$$

With:  $r_3 = -\frac{c}{b}$  and  $r_4 = \frac{c}{\beta}$

Using the solution 1 or the solution 2 in our program calculation leads to a relative error (between the two results) smaller than 0.2 %. But the real interest to neglect the axial thermal conduction inside the fluid, is that this allows us to find an analytical solution without considering  $T_c$  to be constant when we calculate  $T_h$  and without considering  $T_h$  to be constant when we calculate  $T_c$ . Indeed:

}

$$b * \frac{dT_h}{dx} + c * (T_h - T_c) = 0$$

$$- \beta * \frac{dT_c}{dx} + c * (T_c - T_h) = 0$$

$$\begin{array}{l} \Rightarrow \\ b * \frac{dT_h}{dx} = \beta * \frac{dT_c}{dx} \end{array} \left\{ \begin{array}{l} b * \frac{dT_h}{dx} + c * (T_h - T_c) = 0 \end{array} \right.$$

$$\begin{array}{l} \Rightarrow \\ b * \frac{dT_h}{dx} + \left( c - \frac{c * b}{\beta} \right) * T_h = c * T_c(0) - \frac{c * b}{\beta} * T_h(0) \end{array} \left\{ \begin{array}{l} T_c = \frac{b}{\beta} * T_c + T_c(0) - \frac{b}{\beta} * T_h(0) \end{array} \right.$$

Solution 3 :

$$T_h(x) = \left[ \frac{\beta}{\beta - b} (T_h(0) - T_c(0)) \right] * e^{\left( \frac{c - \beta}{\beta - b} \right) x} + \frac{\beta * T_c(0) - b * T_h(0)}{\beta - b}$$

$$T_c(x) = \frac{b}{\beta} * T_h(x) + T_c(0) - \frac{b}{\beta} * T_h(0)$$

In our program, we will use the solution 3. Knowing  $T_c(0)$ ,  $T_h(0)$ ,  $P_c(0)$  and  $P_h(0)$  we can calculate b, c and  $\beta$  at this end of the heat exchanger (X=0 is the hot end of the heat exchanger). To calculate c we need to estimate  $H_{h \rightarrow c}$  :

$$H_{h \rightarrow c} = \left[ \frac{1}{R_{in} * h_{in}} + \ln \left( \frac{R_{out}}{R_{in}} \right) \right]^{-1} + \frac{1}{R_{out} * h_{out}}$$



For the cold flow (so for  $h_{in}$ ) we use the Watts and Chou correlation when the Reynolds number is above 10 000. When the Reynolds number is lower than 10 000, we always take the minimum between the result given by Watts and Chou and the Gnielinski correlation (which is a standard correlation, so not specially made for supercritical water).

According to the Gnielinski correlation:

$$Nu = \frac{\left(\frac{f}{8}\right) * (Re - 1000) * Pr}{1 + 12.7 \left(\frac{f}{8}\right)^{0.5} \left(Pr^{\frac{2}{3}} - 1\right)}$$

Where  $f = (0.79 * \ln(Re) - 1.64)^{-2}$

For the hot flow (so for  $h_{out}$ ), we use the Dittus-Boelter correlation (for the cooling of the flow) if Re is above 10000:

$$Nu = 0.023 * Re^{0.8} * Pr^{0.3}$$

If Re is lower than 10000, we use the minimum between the result given by Dittus-Boelter and Gnielinski.

To estimate the conduction through the pipe wall ( $\lambda_{mat}$ ), we use simply the material data find in the program MPDB v5.50.

Using the solution 3, we get  $T_h(1\text{ mm})$  and  $T_c(1\text{ mm})$ . Using the Itaya correlation, we also calculate  $P_h(1\text{ mm})$  and  $P_c(1\text{ mm})$ . With these 4 values, we can calculate the new values of b,  $\beta$  and c corresponding to the condition  $x=1\text{ mm}$ . This process is iterated until we get  $T_c(x) = 250^\circ\text{C}$  (the temperature of the cold flow at the cold end of the heat exchanger). At the end of this iteration, we get the required length to heat the cold flow from  $250^\circ\text{C}$  to  $T_c(0)$ , the temperature profile of the hot and the cold flow and the friction pressure drop profile also for the hot and the cold flow.

### IV.3 Heat loss consideration

In the previous part (IV.2), we considered the heat loss equal to zero. Anyway, taking into account the heat loss is totally possible. We just have to add in the equation of the external flow (so the hot flow) a term representing the heat exchange between this flow and the room's atmosphere. If we denote the linear power of this heat exchange (so the heat loss between X and X+dX) by "P" we have now:

}

$$b * \frac{dT_h}{dx} + c * (T_h - T_c) = -P$$

$$- \beta * \frac{dT_c}{dx} + c * (T_c - T_h) = 0$$

So the first step is to calculate P. This problem is a classical problem of a horizontal hot cylinder (but only the inner wall temperature is known) in a cooler atmosphere. Here we consider that the pipe (the big pipe of our heat exchanger, the one which contains the bundles of small pipes) is simply a pipe of Inconel 718 with a thickness  $th_B$ , an inner radius  $r_B$  surrounding by a layer of glass wool with a thickness  $th_{gw}$  (see figure 8). We know  $T_{in}$  (the inner temperature) and  $T_{inf}$  (the air temperature far away of the pipe). But we don't know  $T_{out}$  (the surface temperature).

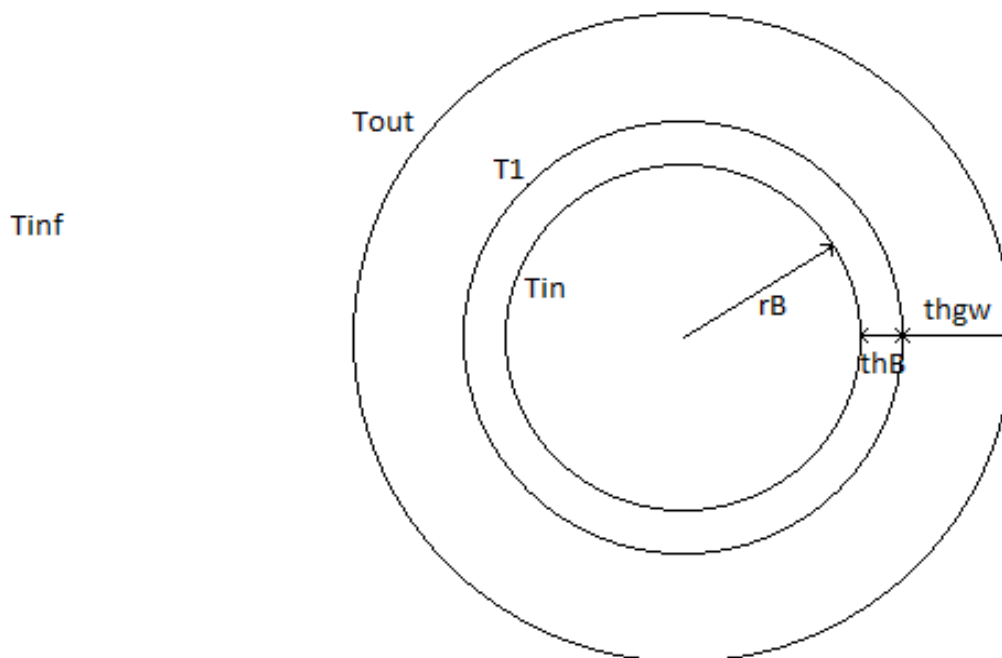

Figure 8: Schematic drawing of the heat exchanger section

If we study what happens at the external wall of the pipe (external wall of the layer of glass wool), we can see that heat transfer will occur in three different ways.

Heat transfer by conduction: The inner part of the pipe is hotter than the outer part of the pipe. So we can consider a radial heat transfer by conduction through the inconel718 and through the glass wool:

$$P_{cond} = \frac{T_{in} - T_{out}}{R_{tot}}$$

With

$$R_{tot} = \frac{\ln\left(\frac{thB + rB}{rB}\right)}{2 * \pi * \lambda_{inc}} + \frac{\ln\left(\frac{thB + rB + thgw}{rB + thB}\right)}{2 * \pi * \lambda_{air}}$$

Where  $\lambda_{inc}$  is the thermal conductivity of the Inconel 718 and  $\lambda_{air}$  is the thermal conductivity of the air.

Heat transfer by convection:  $T_{out}$  and  $T_{inf}$  have no reason to be equal, thus heat transfer due to free convection all around the horizontal pipe will occur. The convective heat transfer is given [7] by:

$$P_{conv} = -\pi * \lambda_{air} * 0.53 * (Ra)^{0.25} * (T_{out} - T_{inf})$$

Where Ra is the Rayleigh number (we took the diameter of the pipe as the characteristic length because the heat exchanger is horizontal).

Heat transfer by radiation: Just like all matter at a temperature above the absolute zero, energy will be emitted by our pipe. According to the Stefan-Boltzmann law we will have:

$$P_{rad} = -2\pi * (thB + rB + thgw) * \epsilon_{gw} * \sigma * (T_{out}^4 - T_{inf}^4)$$

Where  $\epsilon_{gw}$  is the emissivity of glass wool,  $\sigma$  is Stefan's constant ( $5.670400 \cdot 10^{-8} \text{ J}/(\text{s} \cdot \text{m}^2 \cdot \text{K}^4)$ ) and  $T_{out}$  and  $T_{inf}$  are expressed in degrees Kelvin and  $thB$ ,  $rB$  and  $thgw$  are expressed in meter.

We study our heat exchanger for a steady state so energy cannot accumulate in the outer wall of the pipe. Thus, the sum of the energy arriving at the external part of the glass wool layer is equal to zero:

$$P_{cond} + P_{conv} + P_{rad} = 0$$

Using MathCAD, we can find an approximate solution of this last equation (we will find  $T_{out}$ ). Then, we have (noting P the heat loss and X the axial position inside the heat exchanger):

$$P(X) = \frac{T_{in}(X) - T_{out}(X)}{R_{tot}}$$

So whatever the axial position X inside our heat exchanger, we can estimate with this method the heat loss between X and X+dX. Actually, in our program, we will made two assumption which will lead to an overestimation of the heat loss. First we will assume that  $T_{in}$  is equal to the temperature of the hot flow (in reality the temperature of the wall should be lower). Secondly, we will assume that the emissivity of the glass wool is 1 (we didn't find reliable value to estimate this term).

To solve now the simultaneous differential equations we get:

$$\begin{cases} b * \frac{dT_h}{dx} + c * (T_h - T_c) = -P \\ -\beta * \frac{dT_c}{dx} + c * (T_c - T_h) = 0 \end{cases}$$

We will do the same simplifications as in the previous part. So millimeter after millimeter we will assume that only  $T_c$  and  $T_h$  are function of  $X$  but not  $b$ ,  $c$ ,  $\beta$  and  $P$ . As we consider  $b$ ,  $c$ ,  $\beta$  and  $P$  to remain constant for each millimeter, it is now not difficult to find an analytical solution of these simultaneous differential equations:

$$T_h(x) = \left( (T_h(0) - T_c(0) + \frac{P}{c} * (1 + \frac{b}{\beta - b})) \frac{\beta}{\beta - b} \right) \exp\left( \left( \frac{c}{\beta} - \frac{c}{b} \right) x \right) + \frac{P}{\beta - b} \left( x - \frac{\beta}{c} \left( 1 + \frac{b}{\beta - b} \right) \right) + \frac{\beta * T_c(0) - b * T_h(0)}{\beta - b}$$

$$T_c(x) = \frac{b}{\beta} * T_h(x) + T_c(0) - \frac{b}{\beta} * T_h(0) + P * \frac{x}{\beta}$$

So taking into account the heat loss along our heat exchanger is possible but please, note than, according to our results, the total heat loss (assuming a glass wool layer with a thickness of 10 cm) should be smaller than 400 W (for a heat exchanger with a length of 8.4 m and a mass flow of 0.1 kg/s). So it is no more than 0.23 % of the heat that we need to exchange between the hot and the cold flow. Just to give an idea, for the same length and the same mass flow, we should just save 10 W of heat loss putting the cold flow around the small pipes (and so the hot flow inside the small pipes). This difference (0.0056% of the needed heat exchange between the hot and the cold flow) is totally negligible.

## V Analysis of the main results

This part will be devoted to the analysis of the main results we can get using our program. Our program works exactly as described in the section IV “Temperature profile, equations simplifications and solving methods”. The iteration calculation is done using MathCAD and the following results we will present are those by considering heat loss to the outside (with an insulation layer of 10 cm of glass wool). In the following results, we made all the same assumptions as presented before (1 bar pressure drop because of the heater and the in-pile section, 5 kW of gamma heat inside the core, a mass flow of 0.1 kg/s for material test and 0.35 kg/s for fuel test...) and the material and the fuel test heat exchanger are exactly those presented in the section I “Heat exchanger descriptions”.

### *Temperature profile*

The first important result calculated by our program is the temperature profile inside our heat exchanger for the hot flow and the cold flow.

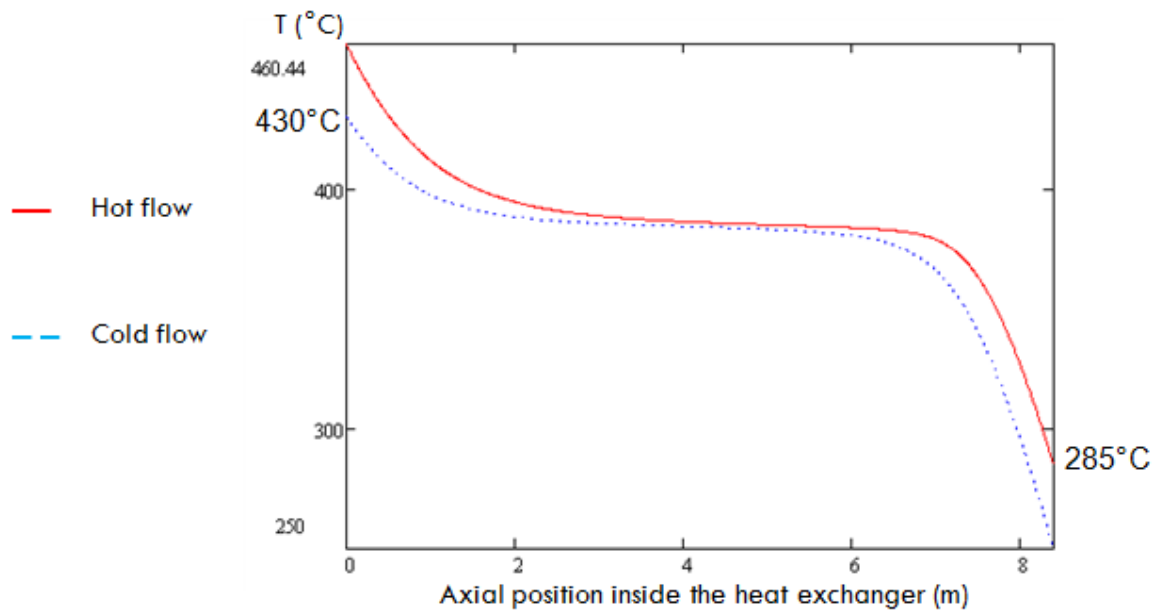

Figure 9: Temperature profile for the material test

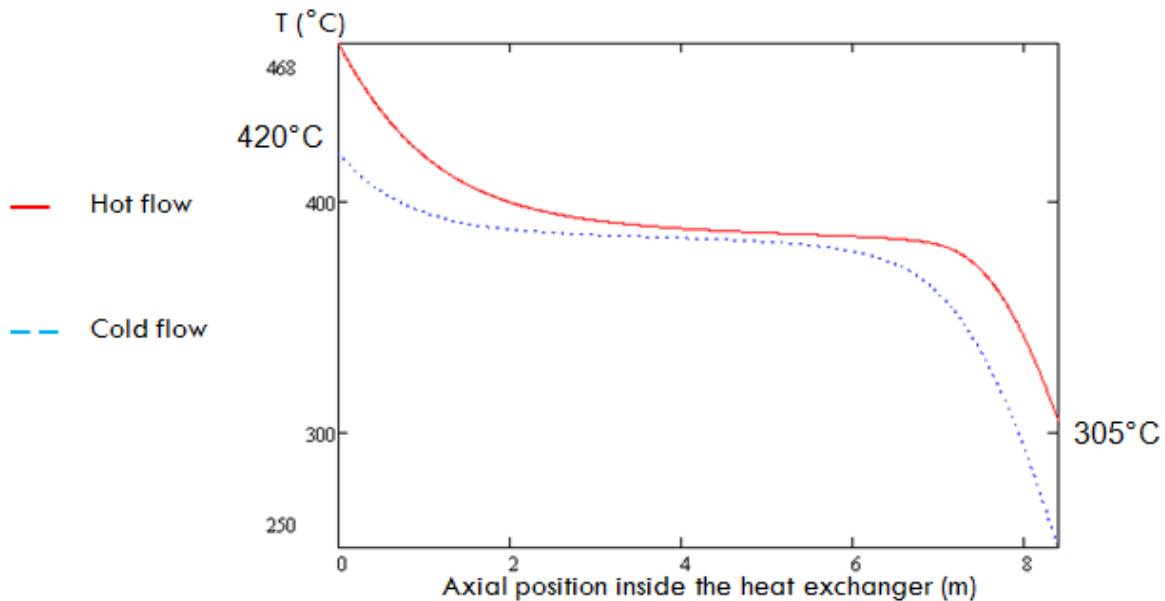

Figure 10: Temperature profile for the fuel test

As one can see, the most noticeable thing is the flat portion of the curves. Whether for the material test result or for the fuel test results, between the third and the sixth meter of our heat exchangers, the variation of the temperature of the two flows remains very low. The temperature stays close to 384°C. Of course, that is not so good for us because that means an important length of our heat exchanger is not very efficient (actually a small change of temperature doesn't mean automatically a small exchange of energy but here we will see that it is the case). Anyway, this is totally due to the thermodynamics properties of water. Close to the temperature of 384°C at 250 bar, the specific heat capacity of water is really high and so that means we need a lot of energy and so a large exchange area to change significantly the temperature of the flow when we are close to this temperature. At the same time, close to this temperature of 384°C, we know that the difference of temperature between the hot and the cold flow will reach its minimum inside the heat exchanger (see section VI "Focus on the pressure drop"), which is not beneficial for the heat transfer. As the temperature difference of the two flows is very low and as one need a lot of energy to change the temperature of the flow close to the temperature of 384°C (the heat capacity is very high), we can understand easily why we get this flat portion. We also understand that it seems impossible to eliminate this problem (it is totally due to the thermodynamics properties of water).

#### *Linear friction pressure drop*

It is absolutely essential to study the pressure drop because we have some limitations to respect because of the pump capacity (no more than 6.6 bars for the whole loop). To estimate the pressure drop, we use the Itaya correlation [5] which is a correlation especially made to calculate friction pressure drop for fluid under supercritical pressure (see the section III "SCW correlations"). The results we got for material test and for fuel test heat exchanger are shown in figure 11 and 12:

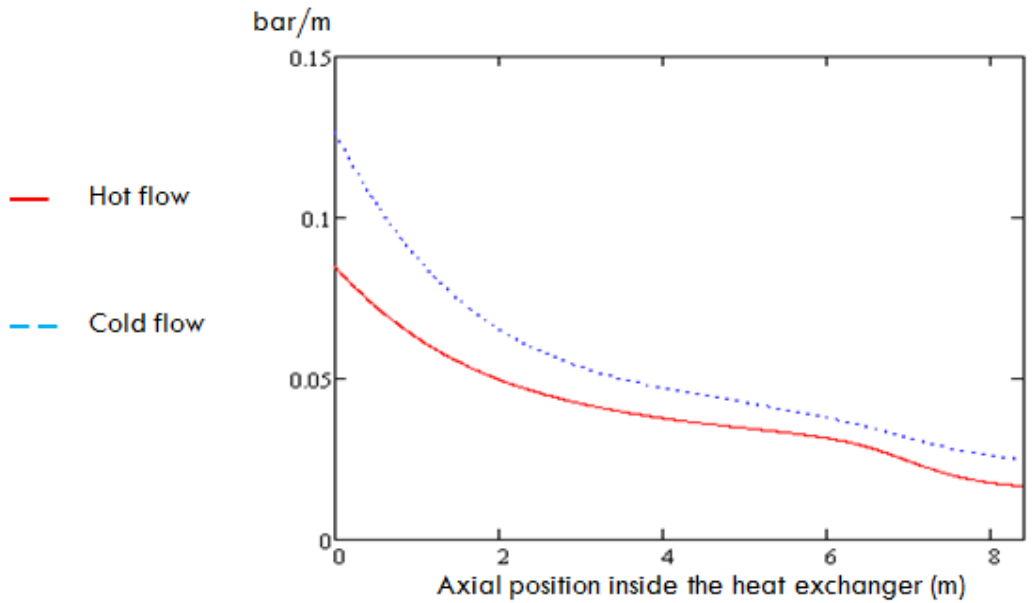

Figure 11: Linear friction pressure drop for the material test

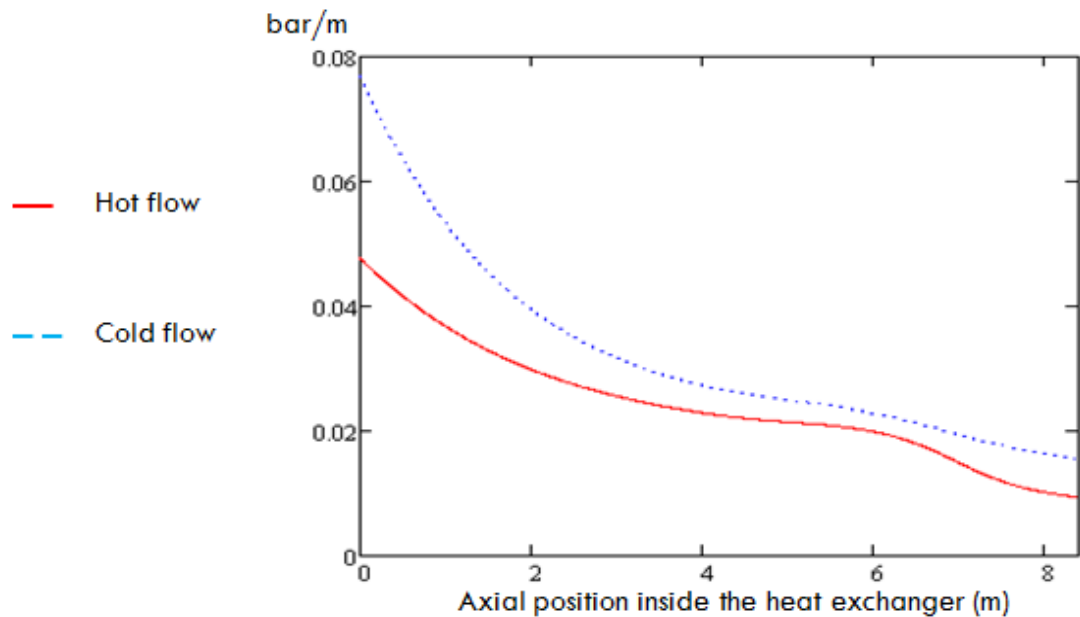

Figure 12: Linear friction pressure drop for the fuel test

In both cases (material and fuel test), the pressure drop of the cold flow is higher than the pressure drop of the hot flow. Of course, the density of the hot flow is lower than the density of the cold flow (the hot flow is hotter than the cold flow) so the hot flow will expand more but at the same time, the cross section of the hot flow is larger than the cross section of the cold flow ( $A_{out} \approx 1.5 A_{in}$ ). This is because we don't want to decrease the distance between two small pipes lower than 0.5 mm. When the distance between the small pipes gets smaller, it becomes more difficult for the hot flow to penetrate in between the bundle of small pipes. With a minimal distance of 0.5 mm between two

small pipes, we cannot get a better ratio than 1.5 between the cross section of the hot flow and the cross section of the cold flow. This geometrical characteristic explains why the pressure drop is lower for the hot flow than for the cold flow.

But the main thing to keep in mind is that we have, in both cases, a large margin according to the pump limitation for the pressure drop (which is 6.6 bars). In fact, the total friction pressure drop is about 0.8 bar for the material test (0.45 bar for the cold flow and 0.35 bar for the hot flow) and about 0.48 bar for the fuel test (0.27 bar for the cold flow and 0.203 bar for the hot flow). As the Itaya correlation has a relative error smaller than 15% (relative error between the predicted value and experimental data [5]), we have to increase these values by 15%. Anyway, even with this correction, we find that we should have a total friction pressure drop (inside the heat exchanger) smaller than 1 bar ( $0.8 \times 1.15 = 0.92$  bar). This is an important result that we will be able to use later (see the section VII.5 when we discuss about the solution to keep straight and combined all the small pipes).

### Heat transfer coefficients

We are always talking about “the” heat exchange inside our heat exchanger. Actually, this heat transfer can be divided in three successive heat transfers. To pass the heat from the hot flow to the cold flow, first one needs to exchange energy from the hot flow to the pipe outer wall (this heat transfer is shown with the red curve in figure 13 and 14). Then the heat will progress through the pipe by conduction (this is the green curve in figure 13 and 14) and then the heat will pass from the pipe inner wall to the cold flow (which is the blue curve in figure 13 and 14):

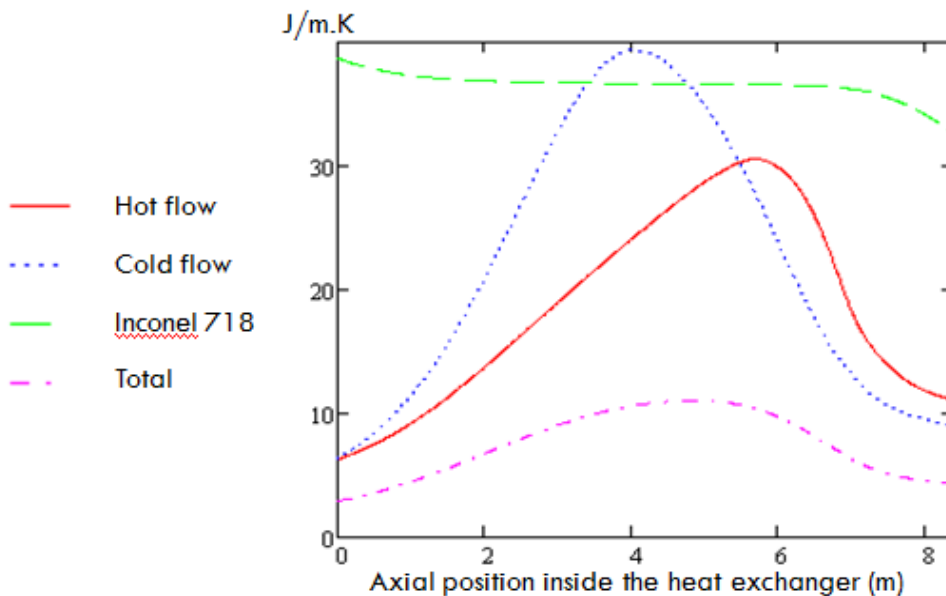

Figure 13: Heat transfer coefficients for the material test



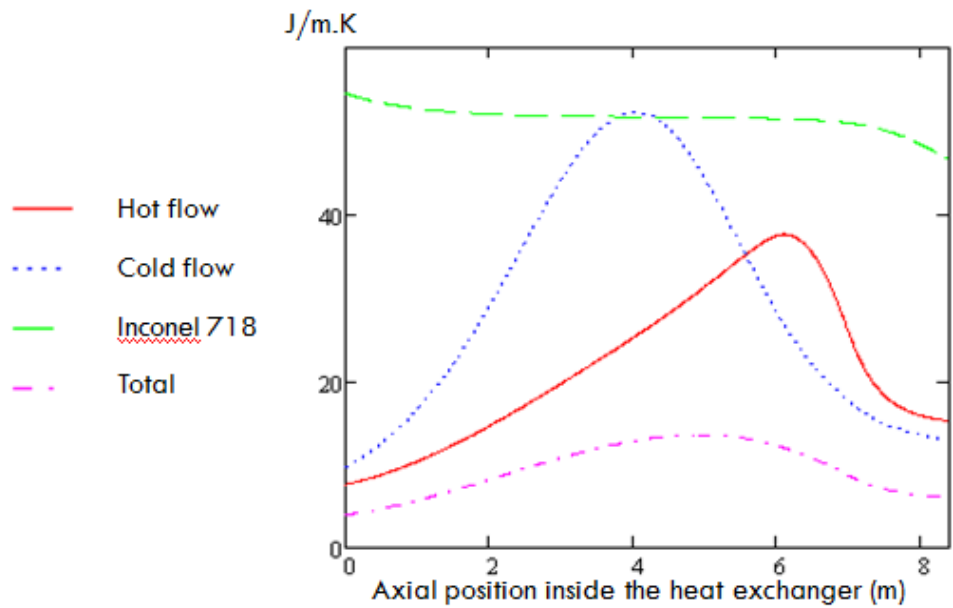

Figure 14: Heat transfer coefficients for the fuel test

The reciprocal of the total Heat transfer coefficient (the pink curve in figure 13 and 14) is simply the sum of the reciprocals of these three components (exactly like resistances in a parallel circuit). These graphs are useful because they show which one is the limiting heat transfer. For example, here, you can see that for both case there is not really a need to reduce the thickness of the small pipe or to find a material with a higher thermal conductivity because the green curve is already almost everywhere above the blue and the red curve. As we sum the reciprocals, the best way to improve the total heat transfer is always to increase the smallest component. Here that means that to improve effectively the total heat transfer, we should find a way to improve the heat transfer between the hot flow and the pipe wall. That could be done adding some structures (small rings for instance) around the small pipes to increase turbulence inside the hot flow (see also the section VII.5 especially when we discuss the different ways to support all the small pipes). These additional structures will also increase the pressure drop but as we have a margin between our margin and our pump limitation, this problem should be overcome.

### Linear heat transfer

The last important result we can get with our MathCAD program is the linear heat transfer. That means for each axial position inside the heat exchanger, we calculate the amount of energy exchanged from the hot flow to the cold flow.

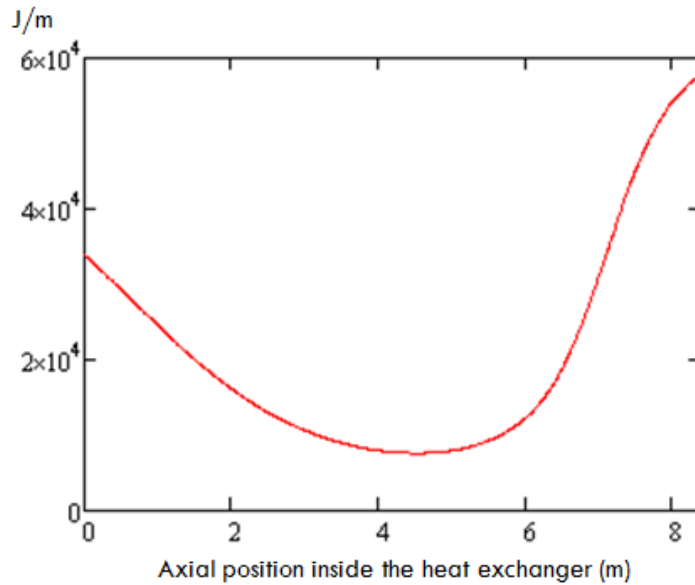

Figure 15: Linear heat transfer for the material test

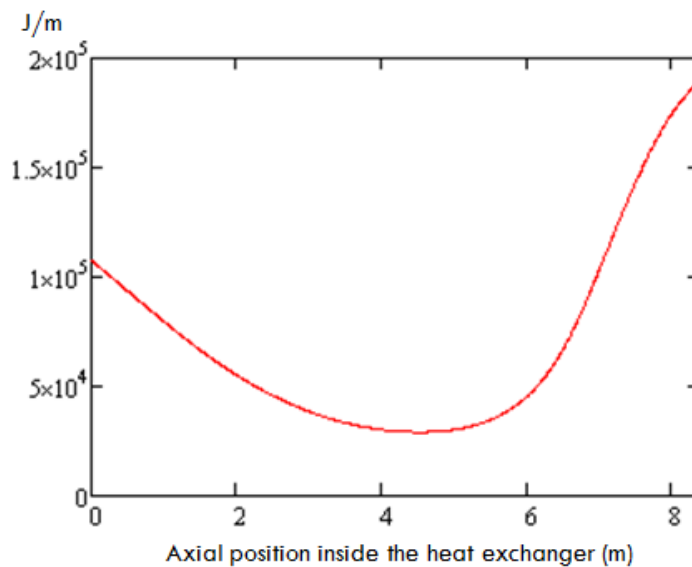

Figure 16: Linear heat transfer for the fuel test

These curves give us important information. As one can see, in the middle part of the heat exchanger (so close to 384°C), the heat transfer is very low. This is due to the very small difference of temperature between the hot and the cold flow in this location. So on the one hand that means that we have a long part of our heat exchanger with a very small efficiency for the heat exchange but on the other hand it also means that we can easily reduce the length of our heat exchanger without increase too much the needed power of our heater. Indeed, the total heat exchange is represented by the area below the curves. As one can see, the area below the curves between the third and the sixth meter is only a small part of the total area (it is 15 % of the total area for the material test).

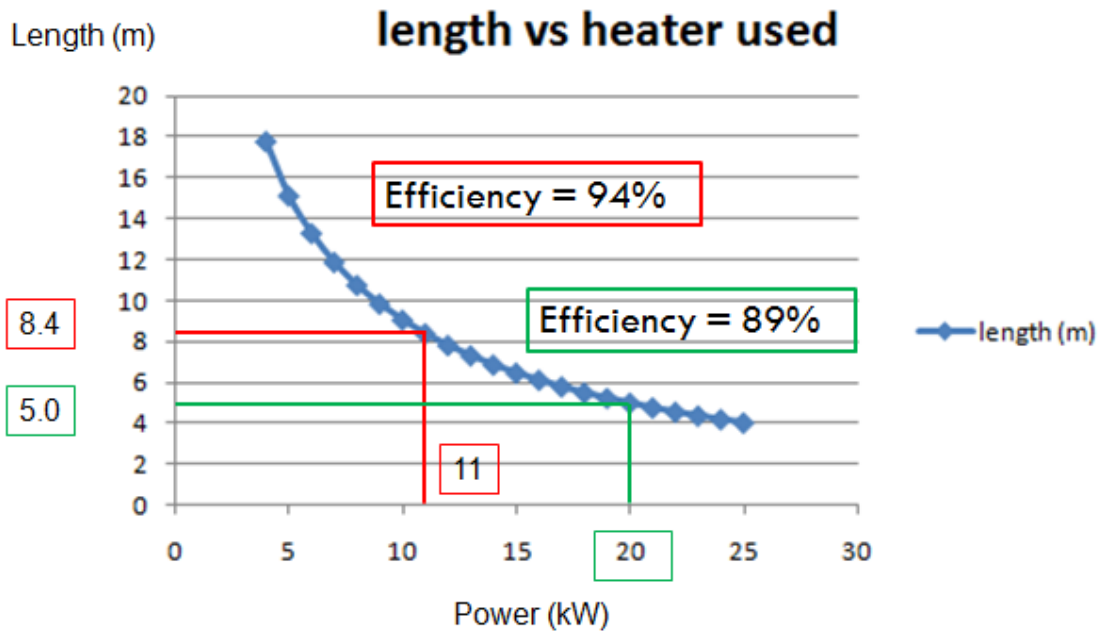

Figure 17: length vs heater used to heat the cold flow up to 450°C (for the material test)

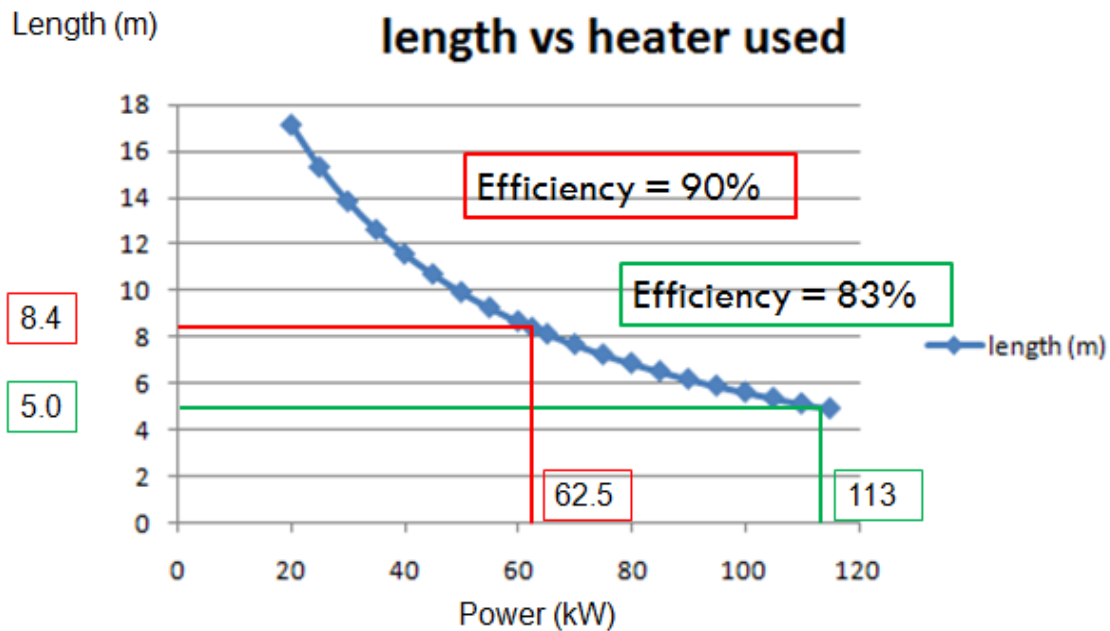

Figure 18: Length vs heater used to heat the cold flow up to 450°C (for the fuel test)

The relations between the length of the heat exchanger versus the required power to increase the temperature of the cold flow from 250°C to 450°C is shown figure 17 and 18. Using a heat exchanger

with a length of 8.4 meters, the expected efficiency (the amount of energy provided to the cold flow by the hot flow) is 94% for a material test and 90% for a fuel test. As we can see here, if we use a heater of 20 kW for a material test or a heater of 113 kW for a fuel test, a length of only 5 meter should be enough (note that according to our result it seems more easy to reduce the length of the heat exchanger for a material test than for a fuel test). So it is hard to say what is the better choice, it really depends on the price to build a long heat exchanger and it is too early to know it right now because we still have some technical problems to study. But it is good to know that we should be able to reduce the length to only 5 meter while keeping a quite good efficiency (at least for the material test heat exchanger).

## **VI Focus on the pressure drop**

We have already described in the sections III “SCW correlation” and IV “Temperature profile, equations simplifications and solving methods” how we take into account the friction pressure drop inside our heat exchanger. In this part, we will discuss about two different aspects of the pressure drop. The first one is totally theoretical but is useful to understand why the need of information about the pressure drop happening inside the in-pile section (actually between the outlet of the cold flow and the inlet of the hot flow inside the heat exchanger) is crucial. The second one is to explain how we use the program “SF pressure drop 7.0” to estimate the pressure drop for a flow from a pipe and going through a perforated plate.

### **VI.1 Pressure drop and declining efficiency**

In this part, we will assume an ideal counter flow heat exchanger. In those conditions, using the same flow (water) as the cold and the hot flow and assuming the same pressure for the two fluids, the hot and the cold flow should be able to exchange all the heat difference. That means that the cold flow will be heated up to the temperature of the hot flow at the entry of the heat exchanger and the hot flow will be cooled down to the temperature of the cold flow at the entry of the heat exchanger. Such a heat exchanger will be considered as a 100% efficiency heat exchanger.

In our heat exchanger, because of the pressure drop inside the in-pile section (and also the pressure drop inside the heater or inside the connecting pipes...) the pressure of the hot flow will be necessarily lower than the pressure of the cold flow. Because of the wide variation of the heat capacity (of the water) close to the pseudo critical temperature we will see that even with a heat exchanger with an infinite length and no pressure drop, an efficiency of 100% is no more possible.

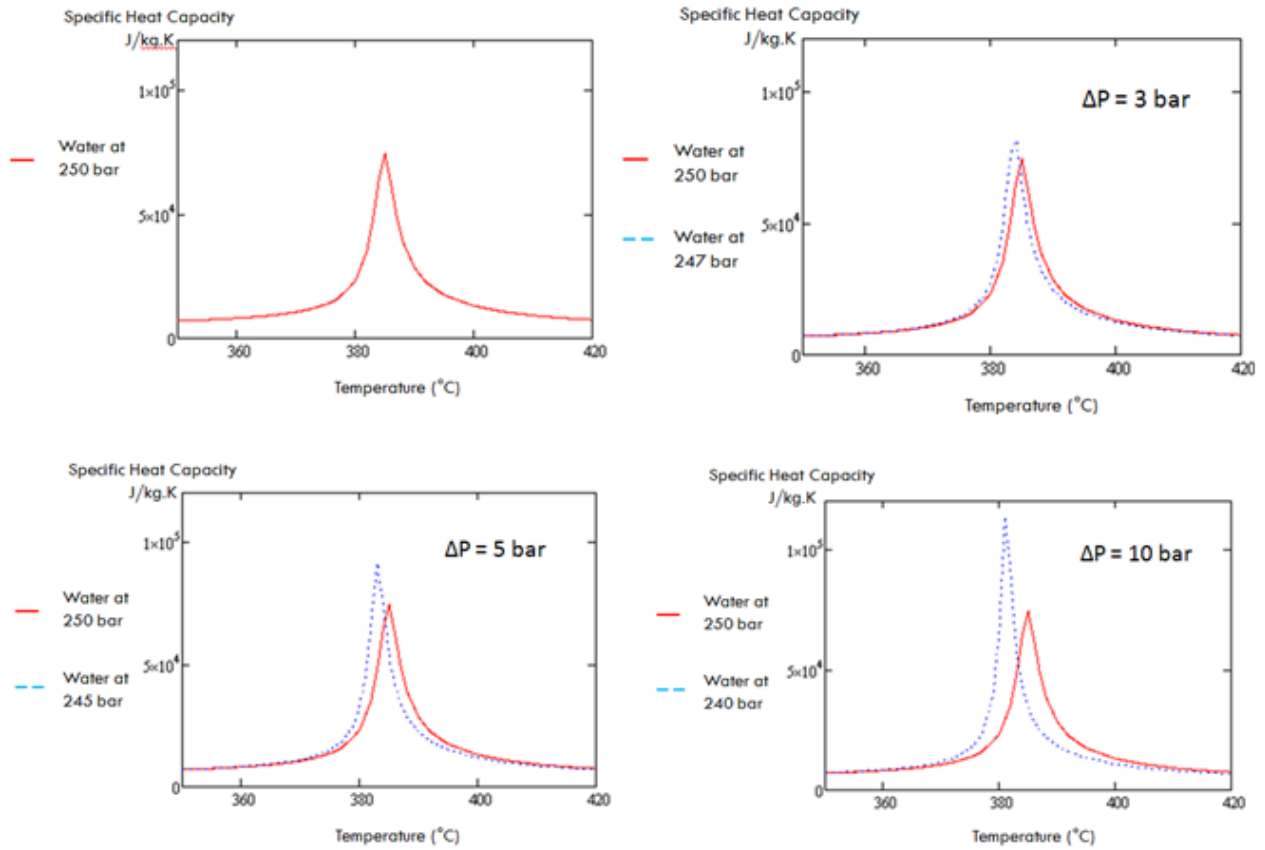

Figure 19: variation of the heat capacity of water because of the pressure

As we can see, the pseudo critical temperature of water decreases when the pressure decreases. For the following, we will denote  $T_{inter}(P1,P2)$  to be the temperature where  $C_p(P1,T) = C_p(P2,T)$ . As we can see on the figure 19, the heat capacity of the hot flow (the one with a lower pressure) will be higher than the heat capacity of the cold flow when  $T < T_{inter}$ . If  $T > T_{inter}$ , the heat capacity of the hot flow will be lower than the heat capacity of the cold flow.

The two fluids (hot flow and cold flow) exchange heat so we should have (neglecting the heat loss):

$$C_{p,hot}(P1, T_{hot}) * dT_{hot} = C_{p,cold}(P2, T_{cold}) * dT_{cold}$$

So we can see that when  $T$  is lower than  $T_{inter}(P1, P2)$ ,  $\Delta T$  (the difference of temperature between the hot and the cold flow) decreases when  $T$  increases. When  $T > T_{inter}(P1, P2)$ ,  $\Delta T$  increases when  $T$  increases. So the minimal temperature difference will be reached for  $T = T_{inter}(P1, P2)$ . As we are assuming an ideal heat exchanger, we can consider that  $\Delta T=0$  for  $T=T_{inter}$ . Now, assuming that, we can look what happens if we try for example to heat a flow from  $T_{inter}(240 \text{ bar}, 250 \text{ bar})$  up to  $400^\circ\text{C}$  using a flow initially at a temperature of  $400^\circ\text{C}$  and a pressure of  $240 \text{ bar}$  using an ideal counter flow heat exchanger (so no pressure drop inside and  $\Delta T = 0$  when  $T=T_{inter}$ ):

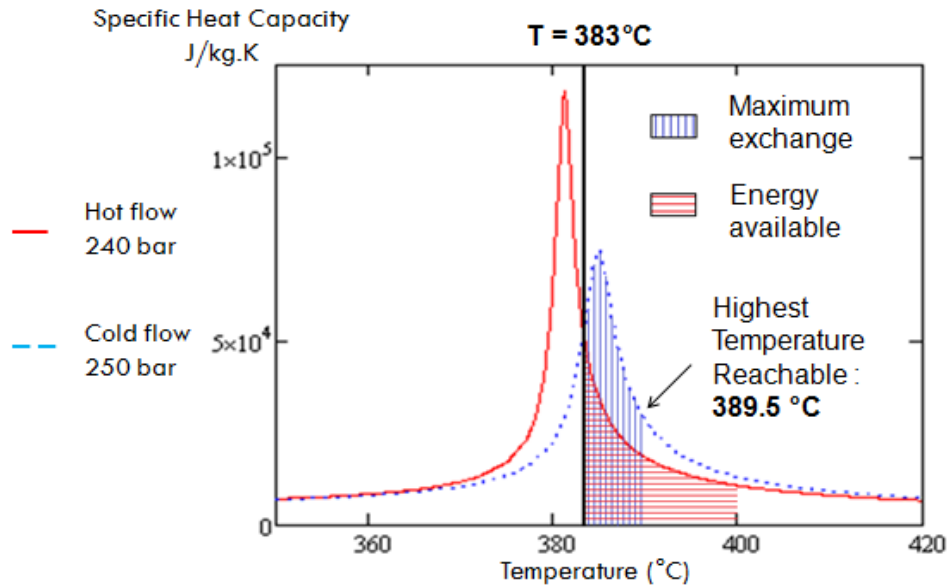

Figure 20: Comparison between the heat available and the heat needed

We can see that just because the heat capacity of the cold flow is above the heat capacity of the hot flow when  $T > T_{inter}$ , the needed energy to heat the cold flow up to  $400^{\circ}\text{C}$  is higher than the energy available inside the hot flow (this energy is represented by the red area under the heat capacity curve between  $T_{inter}$  and  $400^{\circ}\text{C}$ ). So we see that even using an ideal counter flow heat exchanger (blue area = red area) it is impossible to make the cold flow reach the temperature of the hot flow ( $400^{\circ}\text{C}$  in this example).

In our heat exchanger, the difference of pressure will be smaller than 10 bar. We chose this difference just because the phenomena described was more obvious with this important pressure difference (better visible on the curves). Anyway, in the following table (table 4) you can see the result for more likely cases. When we consider the gamma heat from the core, the power is assumed to be 5 kW for a water mass flow of 0.1 kg/s:

|  | $\Delta P = 0$ bar | $\Delta P = 1$ bar | $\Delta P = 2$ bar | $\Delta P = 3$ bar |
|--|--------------------|--------------------|--------------------|--------------------|
| Tcoldout wanted  | 450                | 450                | 450                | 450                |
| Thotout wanted   | 250                | 250                | 250                | 250                |
| heat exchange needed (kW)                              | 186                | 186                | 186                | 186                |
| <b>Perfect Heat Exchanger (without the gamma heat)</b> |                    |                    |                    |                    |
| Max Tcoldout   | 450                | 445                | 441                | 436                |
| Min Thotout  | 250                | 255                | 261                | 267                |
| heater needed (kW)                                     | 0                  | 2                  | 5                  | 7                  |
| cooler needed (kW)                                     | 0                  | 3                  | 5                  | 8                  |
| Heat exchange (kW)                                     | 186                | 184                | 181                | 179                |
| efficiency   | 1                  | 0,989              | 0,973              | 0,962              |
| <b>Perfect Heat Exchanger (considering gamma heat)</b> |                    |                    |                    |                    |
| Max Tcoldout   | 460                | 455                | 450                | 445                |
| Min Thotout  | 250                | 255                | 261                | 267                |
| heater needed (kW)                                     | 0                  | 0                  | 0                  | 2,5                |
| cooler needed (kW)                                     | 5                  | 5                  | 5                  | 7,5                |
| Heat exchange (kW)                                     | 186                | 186                | 186                | 183,5              |
| efficiency   | 1                  | 1                  | 1                  | 0,987              |

**Table 4: Dependence of the efficiency on the difference in pressure between the hot and the cold flow**

In table 4, we called efficiency the ratio between the heat provided by the hot flow to the cold flow and the heat needed by the cold flow to reach the temperature of 450°C. Of course, when we consider the gamma heat inside the core, the initial temperature of the hot flow is higher than the required temperature for the cold flow (about 460°C instead of 450°C). This “extra heat” will be useful to improve the efficiency. Anyway, as you can see in the table, even considering the gamma heat, one will need an additional heater after the heat exchanger to heat the cold flow up to 450°C when the difference of pressure between the hot and the cold flow is above 2 bar (because even using an ideal heat exchanger, we cannot make the cold flow reach the wanted temperature of 450°C for a too important difference of pressure). For instance, the maximum temperature reachable with a difference of 3 bar (cold flow 250 bar and hot flow 247 bar) is 445°C.

Here are some results to demonstrate how the efficiency of a real heat exchanger depends (according to our model) on the pressure drop because of the in-pile section (and the heater and the connection pipes). Those results are obtained for a mass flow of 0.1 kg/s, assuming a gamma heat of 5 kW and no additional heating inside the core (so it is a material test and no a fuel test). We assume 61 small pipes of 2 mm inner diameter and 3 mm outer diameter made in Inconel 718. All the pipes are inside a bigger pipe with an inner diameter of 30.3 mm. The total length is 8.4 m (or three identical units of 2.8 m in series):



|                            | $\Delta P = 0$ bar | $\Delta P = 1$ bar | $\Delta P = 2$ bar | $\Delta P = 3$ bar |
|----------------------------|--------------------|--------------------|--------------------|--------------------|
| Tcoldout wanted            | 450                | 450                | 450                | 450                |
| Thotout wanted             | 250                | 250                | 250                | 250                |
| heat exchange needed (kW)  | 186                | 186                | 186                | 186                |
| <b>Real studied design</b> |                    |                    |                    |                    |
| Tcoldout                   | 432                | 430                | 429                | 427                |
| Thotout                    | 282                | 285                | 288                | 291                |
| heater needed (kW)         | 10                 | 11                 | 12                 | 13                 |
| cooler needed (kW)         | 16                 | 17                 | 18                 | 20                 |
| heat exchange (kW)         | 176                | 175                | 174                | 173                |
| efficiency                 | 0,946              | 0,941              | 0,935              | 0,930              |

Table 5: Dependence of the efficiency on the difference in pressure (for the material test heat exchanger)

## **VI.2 Pressure drop caused by the perforated plates**

Even if we don't know yet how (which method) we will assure the sealing of the small pipes (at both ends of the heat exchanger), we know that anyway, one of the flows (the cold flow) will pass from a connecting pipe (about 30 or 40 mm for the inner diameter) to several narrow pipes (61 with a inner diameter of 2 mm for a material test). So this flow will have to go through a perforated plate (from one big pipe to several small pipes).

To take into account the pressure drop caused by the change of shape, we will use the program "SF Pressure Drop 7.0". This program allows calculating of the pressure drop for a flow across a perforated plate. For the calculation, the program needs to know the density, the viscosity and the throughput of the fluid (in this case it is water) but it needs also to know the diameter of the perforated plate (the inner diameter of the pipe the flow is coming from), the diameter of every small holes on the plate (the inner diameter of our small pipes), the thickness of the plate (the length of the heat exchanger or the length of each unit if we split the heat exchanger in different parts) and the clear area of the perforated plate (ratio between the total holes area and the total plate area). One can see in figure 21 the results we got for a water flow (0.1 kg/s, pressure = 250 bar and temperature = 450°C) passing through a perforated plate with a diameter of 70 mm (the distance between two pipes will be 5 mm like that) and 61 holes (diameter = 2 mm). The result is the pressure drop (in Pa) dependence on the thickness of the plate (in mm):

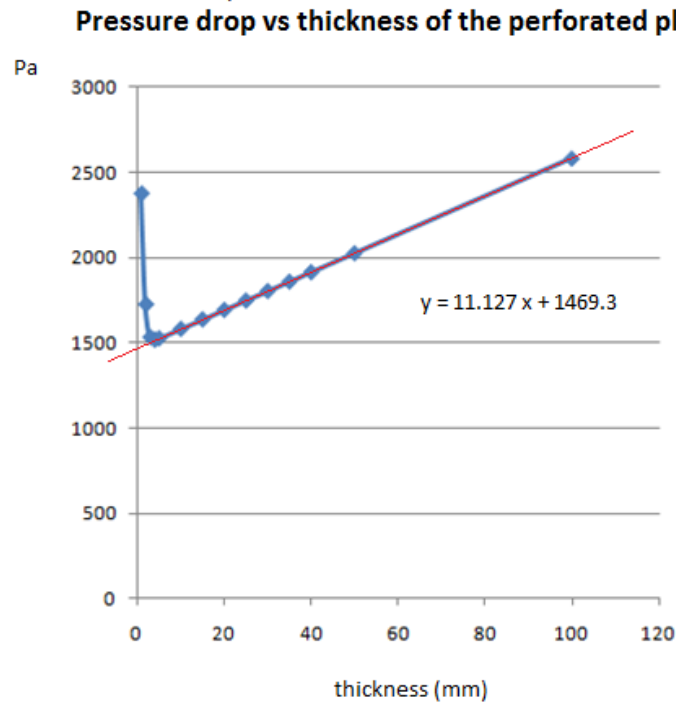

**Figure 21: pressure drop calculated by SF Pressure Drop 7.0 for perforated plate**

As we can see on the figure 21, the results from SF Pressure Drop 7.0 seem to follow a line ( $y = 11.127 \cdot x + 1469.3$ ) as soon as the thickness is longer than 10 mm. Inside our heat exchanger, everything happens exactly as if the thickness of the perforated plate were the length of the heat exchanger (the length of every small pipes, so several meters) so we don't really need to care about what happens (according to SF Pressure Drop 7.0) for very thin perforated plate (thickness < 10 mm). As we see, there is a linear dependence between the thickness and the pressure drop. This is because, in all probability according to the results, SF Pressure Drop take into account the friction pressure drop inside the small holes (small pipes). But we know that SF Pressure Drop 7.0 uses the Colebrook correlation to calculate the pressure drop. In our case (water under supercritical pressure) we know that it is not the best way (just look at section III "SCW correlations").

Anyway, the important result is the value of the pressure drop when  $x=0$  (the linear equation of the line). According to what we found, it seems that when we subtract the friction pressure drop (the term  $11.127 \cdot x$  in our example), we obtain the value of the pressure drop only due to the shape (the flow has to go in and out of the plate and so pressure drop occur just because of that). In this specific example, we can see that the pressure drop due to the shape is about 1500 Pa (0.015 bar). With the exact same kind of perforated plate and the same mass flow (0.1 kg/s), this pressure drop value is about 0.002 bar when the temperature of the flow is 250°C ( $P = 250$  bar) and 0.006 bar when  $T = 385^\circ\text{C}$ .

Unfortunately, there is no way for us to know which part of this pressure drop is due to the entrance of the flow (flow from a pipe going into the perforated plate) and which part of this pressure drop is due to the exit of the flow (flow from the small pipes going into one bigger pipe). So it is difficult to have very precise results because in our heat exchanger, the temperature of the flow (and so the

density, the viscosity...) is not the same at both ends of the heat exchanger. But we can easily made an over estimation of the total pressure drop due to the shape of the perforated plate. If we assume the flow temperature everywhere equal to 450°C and if we split the heat exchanger in three identical units in series (2.8 m long each), we know that the total pressure drop because of the shape of the perforated plate should be about 0.045 bar (0.015 \* 3 = 0.045). So it seems quite realistic to assume that the pressure drop due to the perforated plate will remain smaller than 0.05 bar (which is not very important compare to the friction pressure drop inside the heat exchanger). Another way to do (but it is just a guess and not an over estimation) is to consider that half of the pressure drop is due to the entrance and the other half due to the exit. As the temperatures of the ends are about 250°C and 450°C and inside (the middle part) the temperature is close to 385°C, we can consider that:

$$\Delta P_{\text{tot}} = \frac{\Delta P(T = 250^{\circ}\text{C})}{2} + 2 * \Delta P(T = 385^{\circ}\text{C}) + \frac{\Delta P(T = 450^{\circ}\text{C})}{2}$$

So the total pressure drop because of the shape of the perforated plates could be 0.0205 bar. As we don't have any certainty about this last method, we should keep in mind 0.05 bar as a result more rigorous.

## **VII Different practical problems**

Our program is useful to for obtaining easily an estimation of the required length (for reaching a given efficiency) depending on several physical and geometrical characteristics (mass flow, temperature and pressure for the hot and the cold flow at the heat exchanger's entry but also the number of small pipes, the cross sections, the inner diameter of every pipes, the thickness of every pipes...). If we want to build the heat exchanger however, we also have to find solutions for different practical problems: how to distribute small pipes inside a bigger one? What should be the thickness of our pipes to stand an important pressure (250 bar)? What will be the thermal expansion and what will be the resulting stresses? How to assure the sealing of all the small pipes at both ends of the heat exchanger (how to fix/weld small pipes to the perforated plates)? How to keep all the small pipes combined to avoid collision and/or contact between two pipes and to keep as much as possible the required distribution of the small pipes?

### **VII.1 Small pipes distribution**

Putting several small pipes inside a bigger one is a geometrical problem. At the beginning of our study, we were assuming a distribution following an equilateral triangular mesh (just like in bee hive). Using this way, the density of small pipes inside the bundle is very good (it is the best way to put pipe close to each other) but the problem is at the periphery. If we denote  $N_b$  to be the number of small pipes we works with, one can see on the following drawing this periphery problem:

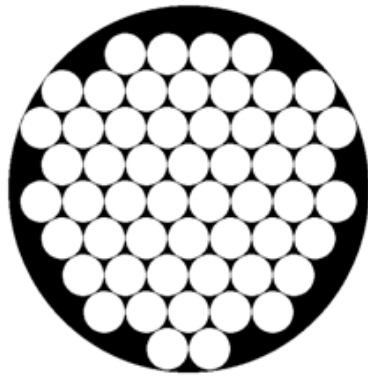

Nb = 54

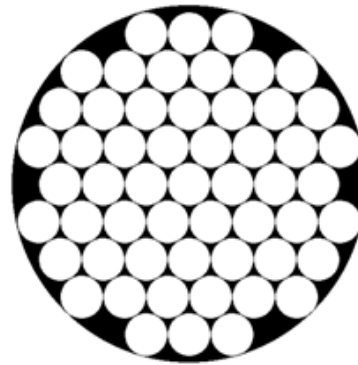

Nb = 55

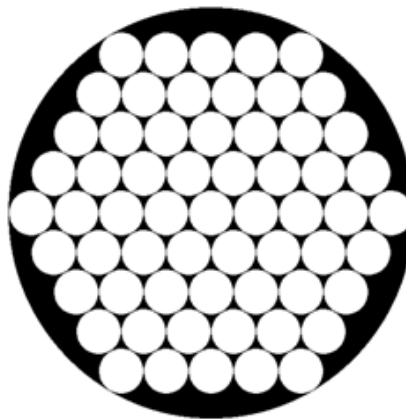

Nb = 61

As one can see, with this method, we can reach a very small distance between two pipes (actually we can put in contact one pipe with its six closer neighbor pipes) but in the periphery (close to the inner wall of the bigger pipe) there is always a lack of pipes (big area without any pipes). So the distribution is really not homogeneous. To find a better way to distribute the small pipes, we used results from [8]. This document studies the best way to put several small circles inside a bigger circle (to put them as close as possible). According to this document, when Nb is a centered hexagonal number (1, 7, 19,...,  $1+6+6*2+\dots+6*n,\dots$ ) It is possible to get a very dense and homogeneous distribution:

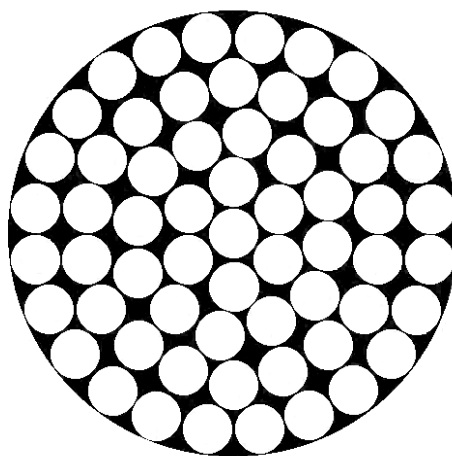

Nb = 61

As one can see, the main idea is to pass little by little from a hexagon (the six pipes around the central pipe) to a circle (the 24 peripheral pipes) to fit well with the inner wall of the big pipe. In the following table (table 6), we will compare this four different shapes assuming a minimal distance between two pipes of 0.5 mm, an inner diameter of 2 mm for the small pipes, a thickness of 0.5 mm. In the table 6,  $A_{in}$  is the cross section of the cold flow (inside the small pipes),  $A_{out}$  is the cross section of the hot flow (around the small pipes) and the length is the required length to heat the cold flow from 250°C to 430°C (that means using after the heat exchanger a heater of 11 kW to heat the cold flow up to 450°C) with a initial hot flow at a temperature of 460°C (and assuming 1 bar pressure drop in the in-pile section). “Density of the geometry” represents the ratio between the total surface taken by all the small pipes and the cross section of the big pipe. The mass flow is 0.1 kg/s:

| number of pipe | density of the geometrie | inner diameter big pipe (mm) | exchange area (m <sup>2</sup> /m) | A <sub>out</sub> /A <sub>in</sub> | Length (m) |
|----------------|--------------------------|------------------------------|-----------------------------------|-----------------------------------|------------|
| 54             | 0,735                    | 30                           | 0,339                             | 1,92                              | 9,746      |
| 55             | 0,816                    | 28,7                         | 0,346                             | 1,49                              | 8,681      |
| 61 (hexagon)   | 0,753                    | 31,5                         | 0,383                             | 1,82                              | 9,085      |
| 61 (circle)    | 0,813                    | 30,3                         | 0,383                             | 1,51                              | 8,391      |

**Table 6: Characteristics of the different distributions**

Of course, in our study, the main result is the expected length. In the table 6, one can see that the best result (the shortest length) is obtained for the fourth geometry, 61 (circle). These results were obtained using our MathCAD program and so assuming a homogeneous distribution of the flow (flow characteristics only depend on the axial position). Anyway, assuming a homogeneous repartition of the flow around the small pipes, the 61 (circle) shape is the best according to our model. Using only 55 pipes leads to a result which is very close (only 30 cm more) but it is clear that the hypothesis of the homogeneous flow distribution is less acceptable for this shape than for the 61 (circle) shape because of the peripheral problem. Because of that, the result for 55 pipes obtained with our program is less reliable than the result obtained for 61 (circle) pipes. Thus, in reality, the length difference should be larger than 30 cm. For sure, between these four different pipes distributions, the 61 (circle) is the one which assures the best distribution (the most homogeneous).

For fuel test, we need a bigger mass flow (about 0.35 kg/s instead of 0.1 kg/s) so to avoid a too high friction pressure drop inside the heat exchanger, we need to use pipe with a larger inner diameter (3 mm instead of 2 mm). At the same time, we need to exchange more energy (the mass flux is more important) so we need a larger exchange area. Thus, we need to use more small pipes. Actually, [8] doesn't study geometry with more than 65 circles. Anyway, we can continue adding from the 61 (circle) shape a peripheral circle of 30 pipes (24+6). That will give us a quite homogeneous distribution with 91 pipes (more suitable for mass flow of about 0.35 kg/s).

## **VII.2 Thickness needed for the pipes**

We work at an important pressure because our goal is to be above the water critical point. At 250 bars, the flow inside the heat exchanger will be at a pressure of 249 bar higher than the room atmosphere. To withstand such a large pressure difference, we need to use a big pipe with a minimal thickness.

The Inconel 718 has the property of having very high yield strength: 1180 MPa at a temperature of 450°C. That means that using this material, we don't need a very thick pipe to withstand a difference of pressure of 249 bar. To get quantitative results about the relation between pressure difference, thickness of the pipe and induced stress (because of the pressure), we use the formula from [9]:

$$st = \frac{\Delta P}{\ln\left(\frac{th}{ri} + 1\right)}$$

Where  $st$  is the maximum stress in the pipe because of the pressure,  $\Delta P$  is the difference in pressure between inside and outside of the pipe,  $th$  is the thickness of the pipe and  $ri$  the inner radius of the pipe. The yield stress of Inconel 718 (the value we have not to exceed) is 1180 MPa. Actually we will take a margin a say that we don't want to be above 500 MPa for the stress. At the same time, we want to work at a pressure of 250 bar (so  $\Delta P = 249$  bar) but we will also take a margin and we will work assuming  $\Delta P = 300$  bar. In this condition, using the previous formula from [9] we can find the minimum required thickness:

$$th = r * \left[ \exp\left(\frac{30}{500}\right) - 1 \right]$$

So now, the thickness only depends on the inner radius of the pipe we will use. For the material test case, using 61 small pipes (inner diameter = 2 mm), the inner radius of the big pipe should be around 15 mm. For the fuel test case, using 91 small pipes (inner diameter = 3 mm), the inner radius of the big pipe should be around 26 mm. With these numbers and using the last formula we find that a thickness of 1 mm will be enough for the material test heat exchanger. For the fuel test heat exchanger, we need a thickness of 1.6 mm.

For the small pipes, normally, the difference of pressure between inside and outside should be very small (maximum a few bars) so it shouldn't be a problem. Anyway, we can check the maximum difference of pressure they can stand with a induced stress smaller than 500 MPa:

$$\Delta P = 500 * \ln\left(\frac{th}{ri} + 1\right)$$

So for pipes with an inner radius of 1 mm and a thickness of 0.5 mm, the maximum difference of pressure to assure a stress less than 500 MPa is above 2000 bar. For pipes with a inner radius of 1 mm and a thickness of 0.5 mm, the maximum difference of pressure is about 1438 bar. Thus, the thickness of our small pipes will be limited more by the difficulties to purchase very thin pipes than by the yield stress of Inconel 718.

### VII.3 Thermal expansion

As we work at high temperature (between 250°C and 450°C), our study would not be rigorous without a study on the thermal expansion and the resulting stresses. In our program, an entire part is included to obtain estimation (even rough) about the thermal expansion and the resulting stresses.

To do that, we will do in parallel two different calculations. One for the big pipe and another one for the small pipes. In a first stage, we consider that the pipes (big pipe and small pipes) are free to expand. Whatever the axial position X inside the heat exchanger, we assume that the temperature of the big pipe is the average temperature between the hot flow temperature (at X) and the temperature of the outer wall of the big pipe (at X) (we know how to get the radial temperature profile of the big pipe and the glass wool layer, see the section IV "Temperature profile, equations simplifications and solving methods" especially the part IV.3 "heat loss consideration"). For the small pipes, we assume that the temperature (at X) is the average temperature between the hot flow temperature (at X) and the cold flow temperature (at X).

Using the data from the commercial software MPDB v5.50, we can get the value of the linear thermal expansion of Inconel 718 (the linear expansion is 0 at 20°C considering as the reference temperature). We call  $\text{linexplnc}$  the function representing the linear expansion of the Inconel 718 depending on the temperature. Assuming that our pipes (the small and the big one) are 2.8 m long at 20°C (we use three identical units in series for a total length of 8.4m) we will estimate how much the length of the pipes would increase if they were free. Between two different axial positions X and Y we have:

$$\text{expansion small pipe} = \int_X^Y \text{linexplnc}(T_{\text{small pipe}}(z)) dz$$

$$\text{expansion big pipe} = \int_X^Y \text{linexplnc}(T_{\text{big pipe}}(z)) dz$$

When we get the two different results, we assume that the big pipe will expand as if it was free, so the length of the big pipe will be  $\text{length}(20^\circ\text{C}) + \text{expansion big pipe}$ . The small pipes are fixed to the big pipe so we will assume that the length of the small pipes are also  $\text{length}(20^\circ\text{C}) + \text{expansion big pipe}$ . As the thermal expansion of the big pipe and the small pipes are different (because the temperature of the small pipes and the big pipe are not exactly the same), there will be stress induced in the small pipes. To get a quantitative result about the stress, we will use the Hooke's law:

$$\sigma = E \cdot \epsilon$$



Where  $\sigma$  is the stress, E the Young's modulus (we got it for the Inconel 718 using the program MPDB v5.50) and  $\epsilon$  is the relative elongation (for us  $\epsilon = (\text{expansion big pipe} - \text{expansion small pipe}) / (\text{length}(20^\circ\text{C}) + \text{expansion small pipe})$ ).

In the following table (table 7), one sees the result we get for each unit of our heat exchanger for a material test heat exchanger and a fuel test heat exchanger:

|                      | thermal expansion big pipe (mm) | thermal expansion small pipe (mm) | induced stress (MPa) |
|----------------------|---------------------------------|-----------------------------------|----------------------|
| <b>material test</b> |                                 |                                   |                      |
| hot part             | 15,428                          | 15,17                             | 17,174               |
| middle part          | 14,455                          | 14,41                             | 2,994                |
| cold part            | 13,517                          | 13,195                            | 21,419               |
| <b>fuel test</b>     |                                 |                                   |                      |
| hot part             | 15,702                          | 15,258                            | 29,451               |
| middle part          | 14,54                           | 14,445                            | 6,252                |
| cold part            | 13,759                          | 13,243                            | 34,351               |

**Table 7: Results about the thermal expansion for each units of our two kind of heat exchanger**

As we can see, the induced stress stays smaller than 35 MPa which is small compared to the yield stress of Inconel 718 (1180 MPa).

Remark: the thermal expansion of the small pipes is always lower than the thermal expansion of the big pipe because the temperature of the small pipes is smaller than the temperature of the big pipe. Thus, the stress will contribute to stretch the small pipes (and will help them to remain straight). That was one of the reasons which made us decide to put the cold flow inside the small pipe and to put the hot flow around the small pipes.

#### **VII.4 Sealing of the pipes**

Regarding the practical realization of such a heat exchanger, one of the main decisions we have to take is to choose a way to assure the sealing of the small pipes (junction between the cold flow connecting pipes and the small pipes inside the heat exchanger).

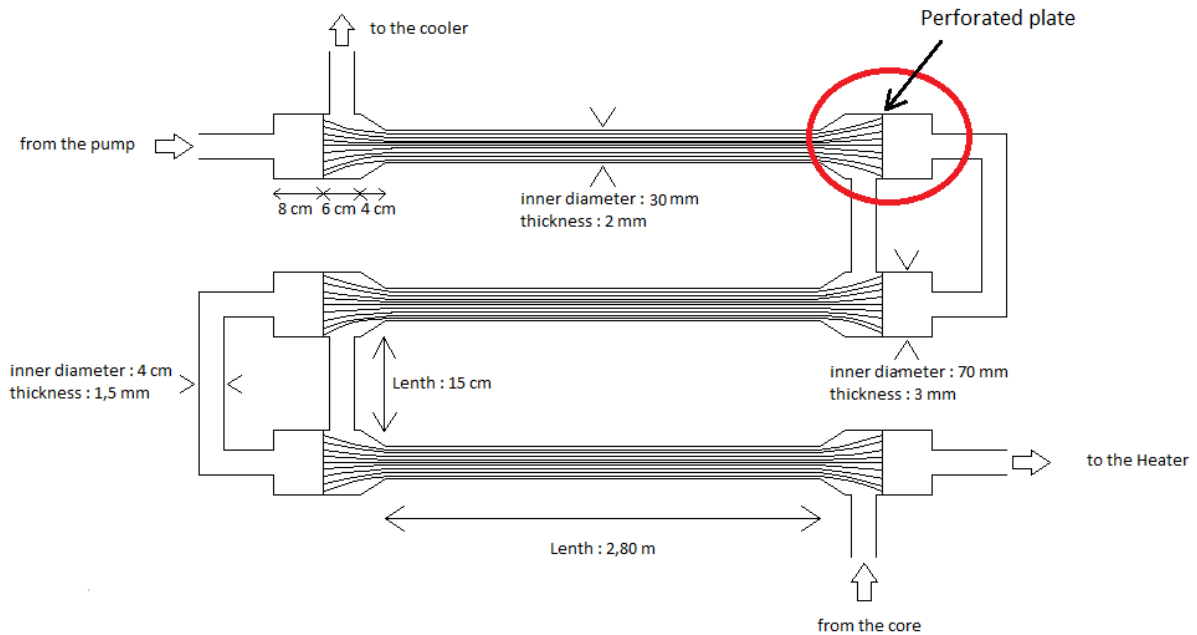

**Figure 22: plan of our material test heat exchanger (using a TIG welding process)**

On this preliminary plan of our heat exchanger (for a material test), we are assuming a Tungsten inert gas welding process but we also consider other possibilities (one of the junctions between cold flow connecting pipes and small pipes is circled in red on the plan).

#### *Tungsten inert gas welding (TIG)*

With this process (which was our first idea), the junction between small pipes and a bigger connecting pipe is assured by a perforated plate. Thus, the sealing depends on the way the small pipes are welded to the perforated plate. Considering a Tungsten inert gas welding, the sealing should be guaranteed but the process could lead to some other difficulties. In fact, the minimal distance between two different welding areas should in this case be about 5 mm. Thus, it will be not possible to put closer than 5 mm two small pipes. If we keep the small pipes straight between the two ends of the heat exchanger, that will mean that the distance between two small pipes inside the heat exchanger will be as large as 5 mm. In this condition, one will need a 48 meters long heat exchanger for a material test (efficiency = 94 %) and a 33 meters long heat exchanger (efficiency = 90%) for a fuel test (the cross section of the hot flow is really too important). With this method, the only way to keep a suitable length would be to bend all the small pipes (as you can see on the Figure 22). According to the IFE's designer, the difficulty with bending is related to the assembly; one has to be able to insert all the small pipes simultaneously through the perforated plates. This is not easy, especially because this has to be done in both ends. As this issue could remain irresolvable, we have also checked other ways to assure the sealing of the pipes. Anyway, note that the penetration of the hot flow in between all the small pipes should be good because when the hot flow arrives inside the

heat exchanger, the distance between two small pipes is larger than the distance between two small pipes in the middle of a unit of the heat exchanger (0.5 mm).

### Graphite seal

Another way could be to use compressed graphite (in between of the small pipes) to assure the sealing. IFE has already a lot of experience with this process but we have to keep in mind that our case is a little bit different. First this process has never been tried with supercritical water. Then, the total surface to be compressed is also larger than the surface IFE (HRP) has experience with. In fact, here we want to work with almost 100 small pipes (fuel tests) for a total area larger than 21 cm<sup>2</sup>. That means that we will need a lot of force (induced by screwing) and thus the components and threads must be strong enough. Finally, in our case, we would have a seal at both ends and this could complicate the mounting procedure. With this method, it could be possible to have a minimal distance of 0.5 mm between two small pipes. With such a small distance, we could now keep the small pipes straight. So if this process is possible, we should avoid the bending of the small pipes issue. A schematic drawing of the graphite seal method is shown in Figure 23. In this drawing, only 1 pipe has been drawn instead of 61 or 91 (to keep the drawing simple).

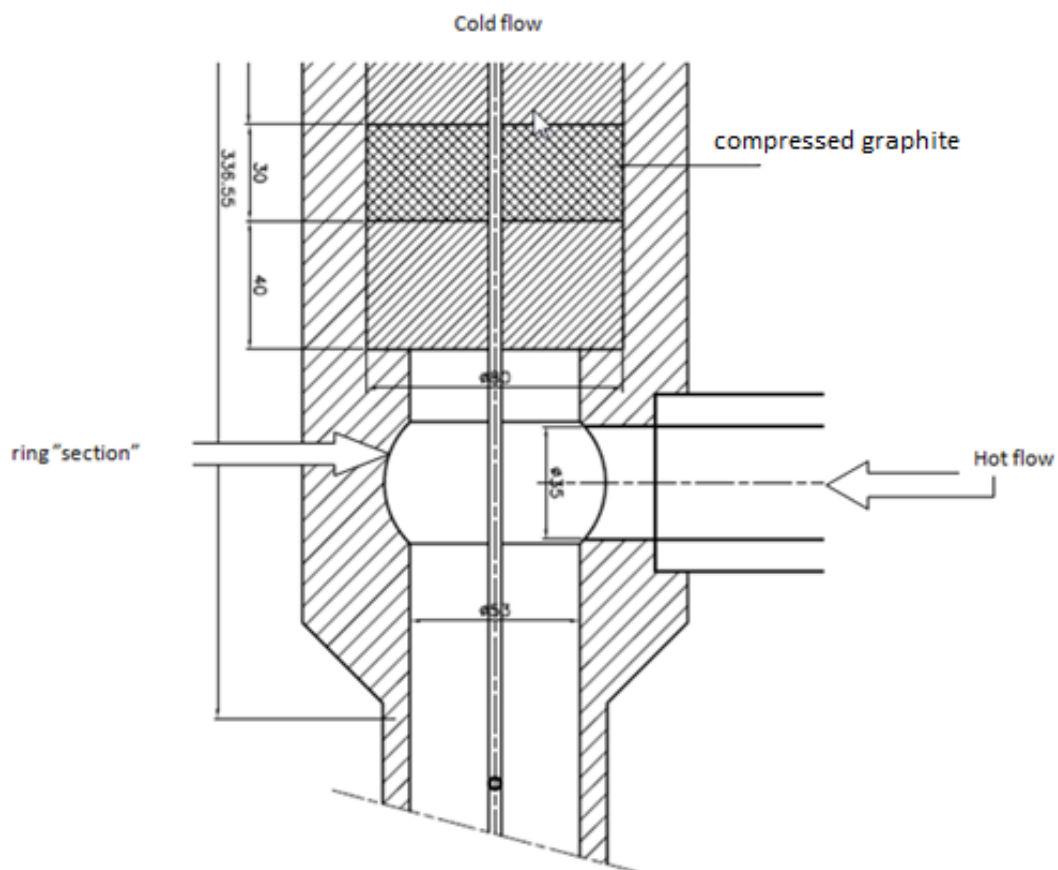

Figure 23: Drawing of the graphite seal method

With the graphite seal design, we don't need to have an enlargement (as we need for the Tungsten inert gas welding) of the bundle of small pipes because it should be possible to keep a distance as small as 0.5 mm between two small pipes. That is why we have added the "ring section" as you can see in Figure 23. The hot flow will have the chance to move around the bundle (circumferential). This should allow the hot flow to penetrate better in between all the small pipes.

#### *Induction brazing*

The last method we considered is an induction brazing process\*. Because of the long length of our heat exchanger (about 2.80 m for each units), it should be a procedure which is not carried out under vacuum. Just like with the graphite seal process, we should be able with this method to keep a distance as small as 0.5 mm between two pipes (has to be confirmed by the company which does the brazing after a detailed discussion). The sealing will be assured by a perforated plate instead of compressed graphite. This method will allow us to keep the small pipes straight (no bending pipes issue) and is guaranteed tight. To facilitate the hot flow penetration in between all the small pipes, we will also add the "ring section" at the entrance of the hot flow inside the heat exchanger (see the graphite seal method drawing). As this solution seems to be more expensive than the other ones, we consider the brazing method as the last option in case everything else would fail (graphite seal and TIG).

\*Induction brazing [10]: it is a materials-joining process that uses a filler metal (and usually an anti-oxidizing solvent called flux) to join two pieces of close-fitting metal together without melting the base materials. Instead, induced heat melts the filler, which is then drawn into the base materials by capillarity action. With the induction brazing, only narrowly defined areas are heated, leaving the adjacent areas unaffected.

#### **VII.5 Keeping the small pipes straight and combined**

In our current and more advanced plan for our heat exchanger (material test or fuel test), we consider three units with a length of 3 meters long for the heat transfer (so we need small pipes of about 3 meters long). With such a length, for a practical design, the pipes should not be free hanging between the two ends of each unit. For instance, the flow induced oscillations could destroy the inner pipes over a short period. In addition, if we let the small pipes free to move over a distance of 3 meter, the equidistribution of the small pipes will be affected. Just because of gravity, there will be too many pipes in the lower part (in contact with each other) and a lack of small pipes (and so manly the hot flow) in the upper part of the heat exchanger. That will lead to a decrease of our heat exchanger efficiency. For these reasons, we need to use regular supports of some form to keep everything in place and to avoid collisions.

#### *Estimation of the deflection due to gravity*

We use several small pipes with both ends are attached and fixed (to the perforated plates or the compressed graphite). The pipes length is about 3 meter, the thickness is 0.5 mm and the inner diameter is 2 mm (material test) or 3 mm (fuel test). The used material for these pipes is Inonel718 and we know (from MPDB v5.50) the Young's modulus (about  $1.8 \cdot 10^{11}$  Pa in our temperature range) and the density ( $8100 \text{ kg/m}^3$  in our temperature range) of this material. Using results from the Euler-Bernoulli beam theory, we can try to calculate the maximal deflection of our small pipes (the maximal deflection occur at the middle of each unit of the heat exchanger so when  $x=1.5$  m if the total length of each small pipes is 3 m). The maximal deflection in our case should be [11]:

$$\text{Deflection}_{\text{max}} = \frac{q \cdot L^4}{384 \cdot E \cdot I}$$

Where  $q$  is the linear weight of one small pipe,  $L$  is the length,  $E$  is the Young's modulus of Inconel718 and  $I$  is the second moment of area. In our case, it is an annular cross section (it is a pipe) so we have  $I = \pi \cdot (\text{Dout}^4 - \text{Din}^4) / 64$  with  $\text{Dout}$  the outer diameter of a small pipe and  $\text{Din}$  the inner diameter of a small pipe.

Considering the gravity of earth equal to  $9.81 \text{ m/s}^2$  we find that the expected maximal deflection should be 11 cm for small pipes used for material test and 6 cm for small pipes used for fuel test. Those results seem to be an overestimation. Actually, in the Euler-Bernoulli beam theory, one of the hypotheses is that the minimum railway curve radius of the beam (of our pipe) should be small compare to its length. With a deflection of 11 cm for a length of 3 meters, we are a little bit out this assumption and so we should keep some distance with our numerical results. Anyway, we can conclude that for sure, the minimum railway curve radius of our pipes (for material or fuel test) will be not negligible in front of the small pipe's length. Thus, we can be sure that the maximal deflection will be at least several millimeters.

As we have to put all the small pipes in a bigger pipe with an inner diameter of 30 mm (material test) or 52 mm (fuel test), a deflection of several millimeters is really not negligible. A structure to keep the pipes straight is indispensable.

### *Possible structures*

To be sure that the small pipes will be prevented from oscillating and that everything will be kept in place, we need to use regular support. A relatively easy way would be to put tight rings of Inconel 718 around all the small pipes and point-weld these ring to prevent them from sliding along the length of the small pipes. We still have to determine the required distance between two rings (the axial distance) but that would be something close to 20 cm. We also need to think how to distribute all the rings. It would be not so good to put all the rings (ring for all small pipes) at the same axial positions because at for these axial positions, the cross section of the hot flow will be reduced strongly and the induced pressure drop could be very high.

Another possible way could be to use fractional perforated plate (for instance sixth of a perforated plate) at a few locations. We could arrange this different sixth perforated plate in a helical way. That should stabilize the small pipes and also orient the hot flow spirally inside the heat exchanger. That will also force the hot flow to penetrate in between the bundle of pipes, which would be beneficial for the efficiency of the heat exchange.

Of course, we still have to study these different possibilities (it is just some idea yet) but we already know some general conclusions. First it will be not possible to build our heat exchanger without this kind of structure (we need some support to keep everything in place). Whatever kind of structure we will chose, the pressure drop for the hot flow will increase (these structures are additional obstacles for the hot flow) and at the same time, the turbulence inside the hot flow will increase (which is a good thing regarding the heat transfer). As the limiting heat transfer is always the one between the hot flow and the outer wall of the small pipes (see the section V "Analysis of the main results") it could be very interesting to improve this heat transfer. Increasing the turbulence inside the hot flow could be a good way to do that. Furthermore, according to our results, the pressure drop is still not so important (our pump limitation is 6.6 bar) so we have some margin to add structure even if these structures will lead to a higher pressure drop.

## **Conclusion**

As it was shown in this report, a lot of results have been obtained concerning the required heat exchanger. According to the results, it seems possible to build a heat exchanger (three units of 2.8 meter long each) with an efficiency of 94% for material test (using 61 small pipes) and 90% for fuel test (using 91 small pipes). Room limitation (the available space) and price are our real limitations (one can improve the efficiency increasing the length but we need more space and/or we need to use more than three units which will be more expensive). The pressure drop was found to be not the main problem; the total pressure drop because of the heat exchanger should be smaller than 1 bar (without considering the structure to keep all the small pipes straight and combined).

Of course, these results have been obtained assuming all the simplifications we detailed in the different parts of this report and so we need to be cautious. These results are not exact (we don't have this pretention) but should give us a good order of magnitude. To improve the precision of our calculations, we could perform several things. First, one should be aware of the fact that the heat transfer coefficient relations we used are only approximate. Finding these relations is the subject of a large international effort and more exact expressions will undoubtedly be available in the future. We also have to keep in mind that we didn't find any correlation to estimate the heat transfer coefficient for the cooling of the flow. That is maybe the biggest weakness of our MathCAD program and it could be useful to improve it (to find a correlation). Several University work on SCW heat transfer and we could maybe contact them (The University of Wisconsin which have built a SCW heat transfer facility or Kyushu University which have already published several results about SCW heat transfer). Further, all our calculations are essentially simple analytical evaluation in one dimension (we only consider the axial position inside the heat exchanger). To get very reliable results, one should perform a finite element calculation in 3 dimensions for a problem which is not axisymmetric. This is not so easy and one needs a very specific computational fluid dynamics code to do that like ANSYS for instance. Finally, we should come to a conclusion on the best way for realizing the sealing of the pipes. The final shape of our heat exchanger will depend on this choice and so to get very precise results, we need to know it.

Furthermore, the efficiency of our heat exchanger depends strongly on the relation between the mass flow of water and the conditions (temperature and pressure) of the water out of the core. As there is still no certainty about the in-pile section design, it is hard to get certainty (very precise results) about the heat exchanger design. Anyway, the MathCAD program we wrote is very flexible and so it is possible to change the initial conditions (mass flow, temperature, pressure...) and get the same kind of results we presented in this report.

Finally, in all our report we have studied the two heat exchangers (material and fuel test) in parallel but it could be also interested to have an idea about what will happen if we used our fuel test heat exchanger with the material test conditions. Please, find a table which some up the results in the Appendix 1.

## **Acknowledgements**

First of all, I really want to convey all my gratitude to my two direct supervisors during this study, who were Rudi Van Nieuwenhove as the project leader (IFE) and Erik Nonboel (Risoe-DTU). The valuable assistance they provided me each time I needed and their wise advice were really important and such a work could not have been achieved without them.

Great thanks also to Bent Lauritzen, head of program “Radiation Physics” in the Radiation Research Division at Risoe-DTU. He always showed high interest for my work and always managed to find a way to devote time to me in spite of his busy schedule. I also want to thank him for having given me the opportunity to present my results during the « XVth meeting on Reactor Physics Calculations in the Nordic Countries » in Helsinki the 12<sup>th</sup> and 13<sup>th</sup> of April 2011.

NKS, IFE and Risoe-DTU are also gratefully acknowledged for having partially funded this work.

Finally, I want to thank all my coworker from IFE and Risoe-DTU for their amiability and their kindness. They all contributed to create a pleasant atmosphere which seems indispensable to do quality work.



## References

- [1]- *Heat transfer at super critical pressure. X. Cheng and T. Schulenberg. Forschungszentrum Karlsruhe GmbH, 2001.*
- [2]- *Numerical analysis of deterioration phenomena in heat transfert to supercritical water. S. Koshizuka, N. Takano and Y. Oka. International Journal of Heat and Mass Transfer, 1995.*
- [3]- *Supercritical water heat transfer. J. R. Licht, M. H. Anderson and Michael L. Corradini. NUCLEAR ENERGY REVIEW, 2006.*
- [4]- *Heat transfer to supercritical pressure carbon dioxide flowing upward through tubes and a narrow annulus passage. Hyungrae Kim, Hwan Yeol Kim, Jin Ho Song, Yoon Yeong Bae. PROGRESS IN NUCLEAR ENERGY, 2008.*
- [5]- *Heat transfer and pressure drop of supercritical pressure fluid flowing in a tube of small diameter. Tohru Yamashita, Hideo Mori, Suguru Yoshida and Masaki Ohno. Memoirs of the Faculty of Engineering, Kyushu University, December 2003.*
- [6]- *Forced convective heat transfer to supercritical water flowing in tubes. K. Yamagata, K. Nishikawa, S. Hasegawa, T. Fujii, S. Yoshida. International Journal of Heat and Mass Transfer, 1971.*
- [7]- *Transfert thermiques convectifs, 3eme année. Ph. Marty (IUP Génie des systèmes Industriels de Grenoble).*
- [8]- *Dense packings of congruent circles in a circle. R.L. Graham, B.D. Lubachevsky, K.J. Nurmela, P.R.J. Ostergard. DISCRETE MATHEMATICS, 1998.*
- [9]- *Formula for stress and strain. Raymond J. Roark, fourth edition, McGraw-Hill book company, New York, 1965.*
- [10]- *Induction Heating Applications, the process, the equipment, the benefits. EFD INDUCTION.*
- [11]- *Euler-Bernoulli beam equation, Wikipedia.*

**Appendix 1:** Results for material test condition using the “fuel test heat exchanger”

| <b>Flow conditions</b>                   |       |
|--|-------|
| mass flow (kg/s)                         | 0,1   |
| inlet temperature of the cold flow (C°)  | 250   |
| inlet temperature of the hot flow (C°)   | 460   |
| delta P (bar)                            | 1     |
| <b>Heat exchanger characteristics</b>    |       |
| number of units                          | 3     |
| length of each units (m)                 | 2,8   |
| number of small pipes                    | 91    |
| inner diameter of small pipes (mm)       | 3     |
| thickness of small pipes (mm)            | 0,5   |
| inner diameter of the big pipe (mm)      | 52    |
| <b>Results gotten using our program</b>  |       |
| outlet temperature of the cold flow (C°) | 426   |
| outlet temperature of the hot flow (C°)  | 289   |
| friction pressure drop cold flow (bar)   | 0,032 |
| friction pressure drop hot flow (bar)    | 0,021 |
| total friction pressure drop (bar)       | 0,053 |
| needed heater (kW)                       | 14    |
| needed cooler (kW)                       | 19    |
| heat exchanger efficiency                | 0,92  |

In this table (in flow conditions), delta P represents the pressure drop between the outlet of the cold flow and the inlet of the hot flow (so the pressure drop because of the heater, the in-pile section and the connecting pipes).

According to these results, it seems totally possible to use the fuel test heat exchanger even for a material test (the efficiency is quite good: 92%). Anyway, we should keep some distance with these results because in this condition, the mass flux for the cold flow is only around 155 kg/m<sup>2</sup>.s and according to [5] we should use the Watt and Chou correlation for mass flux between 400 and 2000 kg/m<sup>2</sup>.s...

|                      |  |
|----------------------|--|
| Title                | NOMAGE4 activities 2011, Part II, Supercritical water loop   |
| Author(s)            | Pierre Vierstraete (1), Rudi Van Nieuwenhove (2), Bent Lauritzen (3)   |
| Affiliation(s)       | (1) Ecole Nationale Supérieure des mines, France<br>(2) Institutt for Energiteknikk, HRP, Norway<br>(3) Risoe-DTU, Denmark |
| ISBN                 | 978-87-7893-327-0  |
| Date                 | January 2012   |
| Project              | NKS-R / NOMAGE4  |
| No. of pages         | 58   |
| No. of tables        | 7  |
| No. of illustrations | 23   |
| No. of references    | 11   |

**Abstract**

The supercritical water reactor (SCWR) is one of the six different reactor technologies selected for research and development under the Generation IV program. Several countries have shown interest to this concept but up to now, there exist no in-pile facilities to perform the required material and fuel tests.

Working on this direction, the Halden Reactor Project has started an activity in collaboration with Risoe-DTU (with Mr. Rudi Van Nieuwenhove as the project leader) to study the feasibility of a SCW loop in the Halden Reactor, which is a Heavy Boiling Water Reactor (HBWR). The ultimate goal of the project is to design a loop allowing material and fuel test studies at significant mass flow with in-core instrumentation and chemistry control possibilities.

The present report focusses on the main heat exchanger required for such a loop in the Halden Reactor. The goal of this heat exchanger is to assure a supercritical flow state inside the test section (the core side) and a subcritical flow state inside the pump section . The objective is to design the heat exchanger in order to optimize the efficiency of the heat transfer and to respect several requirements as the room available inside the reactor hall, the maximal total pressure drop allowed and so on.

**Key words**            Supercritical water, counter flow heat exchanger, heat exchange, pressure drop, MathCAD modelling.