

Technical University of Denmark



## Research on energy storage at Risø National Laboratory

Jensen, K.; Krenk, Steen; Ottosen, N.S.; Rasmussen, I.; Rathmann, Ole Steen; Reffstrup, J.; Thomsen, K.L.; Vigeholm, B.; Wurtz, J.

*Publication date:*  
1979

*Document Version*  
Publisher's PDF, also known as Version of record

[Link back to DTU Orbit](#)

*Citation (APA):*  
Jensen, K., Krenk, S., Ottosen, N. S., Rasmussen, I., Rathmann, O., Reffstrup, J., ... Wurtz, J. (1979). Research on energy storage at Risø National Laboratory. (Risø-M; No. 2191).

## DTU Library

Technical Information Center of Denmark

---

### General rights

Copyright and moral rights for the publications made accessible in the public portal are retained by the authors and/or other copyright owners and it is a condition of accessing publications that users recognise and abide by the legal requirements associated with these rights.

- Users may download and print one copy of any publication from the public portal for the purpose of private study or research.
- You may not further distribute the material or use it for any profit-making activity or commercial gain
- You may freely distribute the URL identifying the publication in the public portal

If you believe that this document breaches copyright please contact us providing details, and we will remove access to the work immediately and investigate your claim.

Risø-M-2191

RESEARCH ON ENERGY STORAGE AT  
RISØ NATIONAL LABORATORY

K. Jensen, S. Krenk, N.S. Ottosen, I. Rasmussen,  
O. Rathmann, J. Reffstrup, K.L. Thomsen,  
B. Vigeholm, and J. Würtz

Abstract. This paper was presented at the International  
Assembly on Energy Storage held from May 27 to June 1, 1979  
in Dubrovnik, Yugoslavia.

It contains a review of some of the research projects on energy  
storage at Risø National Laboratory. Some of the already  
obtained results are presented together with planned activities  
for the next few years.

Some of the projects are carried out in close cooperation with  
the Laboratory for Energetics at the Technical University of  
Denmark and the Geological Survey of Denmark.

INIS Descriptors for Chapter 2: Seasonal heat storage in aquifers:  
AQUIFERS, DISTRICT HEATING, FINITE ELEMENT METHOD, HEAT STORAGE,  
MATHEMATICAL MODELS, PILOT PLANTS.

UDC 620.92

September 1979

Risø National Laboratory, DK 4000 Roskilde, Denmark

ISBN 87-550-0617-5

ISSN 0418-6435

Risø repro 1979

CONTENTS

	<u>Page</u>
<b>1. GROUND STORAGE FOR THERMAL ENERGY</b>	
by Ole Rathmann .....	5
1.1. General .....	5
1.2. Practical layout .....	5
1.3. Analysis of idealized system .....	6
1.4. Computer simulations .....	11
1.5. Conclusion .....	11
<b>2. SEASONAL HEAT STORAGE IN AQUIFERS</b>	
by Jan Reffstrup and Jørgen Würtz .....	14
2.1. General .....	14
2.2. Pilot plant .....	14
2.3. Mathematical models .....	16
2.3.1. D2AQ .....	16
2.3.2. PORFLOW .....	18
2.4. References .....	18
2.5. Nomenclature .....	23
<b>3. NATURAL GAS STORAGE IN SALT CAVERNS</b>	
by Steen Krenk, Niels Saabye Ottosen, Knud Jensen and Ingv. Rasmussen .....	24
3.1. Introduction .....	24
3.2. Scope of work .....	24
3.3. Field investigation and associated laboratory tests .....	24
3.4. Conceptual design study .....	24
3.5. Rock- mechanical safety .....	26
3.6. Future activities .....	29
3.7. References .....	29

	<u>Page</u>
<b>4. ENERGY STORAGE BASED UPON METAL-HYDROGEN SYSTEMS</b>	
by Bjørn Vigeholm .....	29
4.1. General .....	29
4.2. Results .....	30
4.3. Programme .....	32
4.4. Impact on energy supply .....	32
<b>5. STRATIFIED STORAGE FOR SOLAR HEATING SYSTEMS</b>	
by Knud Ladekarl Thomsen .....	34

## RESEARCH ON ENERGY STORAGE AT RISØ NATIONAL LABORATORY

### ABSTRACT

This paper contains a review of some of the research projects on energy storage at Risø National Laboratory, DK-4000 Roskilde, Denmark. The following activities are mentioned:

1. Ground storage for thermal energy,
2. Seasonal heat storage in aquifers,
3. Natural gas storage in salt caverns,
4. Energy storage based upon metal-hydrogen systems,
5. Stratified storage for solar heating systems.

### 1. GROUND STORAGE FOR THERMAL ENERGY

Ole Rathmann

#### 1.1. General

The planned widespread use of solar energy has accentuated the need for thermal energy storage devices. As solar energy is expected to meet nearly 100% of the residential energy demand for space heating and hot water, large seasonal storage is especially needed. However, in order that such a solar energy system be economical, the cost of seasonal storage per unit of storage capacity must be very low. The reason is that seasonal storage has only one charge-recovery-cycle per year.

The Section of Theoretical Heat Transfer and Hydraulics (of the Department of Reactor Technology) has investigated whether or not a finite volume of ground can be used for this type of storage. To maintain costs low the storage is presumed to be insulated only on top.

#### 1.2. Practical Layout

The size of the seasonal storage was taken to correspond to a single

Ole Rathmann

or a small group of family houses. With this size storage the heat transfer to and from the ground is performed most practically by a closed circuit of heat transfer pipes. In order to avoid excavation, vertical pipes, which can be washed or drilled down, should be chosen. With water as the heat carrying medium the heat transfer pipes are connected to the solar collectors and the space heating and hot water system as shown in Fig. 1.1.

### 1.3. Analysis of Idealized System

In order to get an estimate of the dependence of storage efficiency on storage size an idealized hemispherical ground storage as shown in Fig. 1.2a was analyzed. For simplicity an ideal top insulation was assumed. The heat transfer pipes were represented by simultaneously operating heat sources/drains, homogeneously distributed inside the storage volume, so that within this volume the source strength  $Q$  depended solely on time.

Next, this ideal system was harmonically analyzed by assuming sinusoidal time dependence of  $Q$  and temperature  $T$  as shown in Fig. 1.2b, with  $Q_0$  representing the heat loss. This heat conduction problem may be solved analytically when material properties are constant and the result, in the form of temperature amplitude and -phases, is shown in Fig. 1.3. It is seen that the dimensionless storage radius  $X$  determines how these quantities vary with the relative distance from the centre. When  $X$  is large ( $X \gg 1$ ) the amplitude is fairly constant with a phase angle close to  $90^\circ$  inside the storage volume and falls rapidly to zero outside the storage volume, whereas for small  $X$  ( $X \lesssim 1$ ) the amplitude falls very slowly to zero outside the storage volume. The stationary profile,  $T_0(r) - T_\infty$ , gives the heat loss.

In most cases the maximum temperature "swing"  $\Delta T$  determines the total heat capacity of the storage (Fig. 1.4), as, e.g., one cannot have water at temperatures higher than  $100^\circ\text{C}$  in a non-pressurized system. This leads to the determination of the storage efficiency  $E$  as shown in Fig. 1.5. The strongest dependence is on  $X$ , but  $a = \frac{\Delta T}{T_0 - T_\infty}$  has also a marked influence as  $T_0 - T_\infty$  is responsible for the heat loss.

As an example, for  $a = 1$  one must have  $X > 6$  to get a reasonable efficiency (70%). For ordinary soil with 20 vol. % water content ( $k = 1.5 \frac{\text{W}}{\text{m}^\circ\text{C}}$ ,  $C = 2 \frac{\text{MJ}}{\text{m}^\circ\text{C}}$ ) and  $\Delta t = 1$  year this lower limit corresponds to  $R = 11.6$  m. Such a storage has a volume of  $3300 \text{ m}^3$  and a total heat capacity of 264 GJ or 73400 kWh at a temperature swing of  $40^\circ\text{C}$ , e.g. from  $20^\circ\text{C}$  to  $60^\circ\text{C}$ .

It should be noted that with a storage radius above this limit the assumption of sinusoidal time dependence of the heat input/output  $Q(t)$  is not important, as long as  $Q(t)$  is periodic.

This is so because higher harmonics of  $Q(t)$  will introduce higher harmonics in  $T(r,t)$  corresponding to higher values of  $X$  in Fig. 1.3 with only significant influence inside the storage volume. Thus the total capacity and the efficiency will be almost unchanged.

Research on Energy Storage at Risø National Laboratory

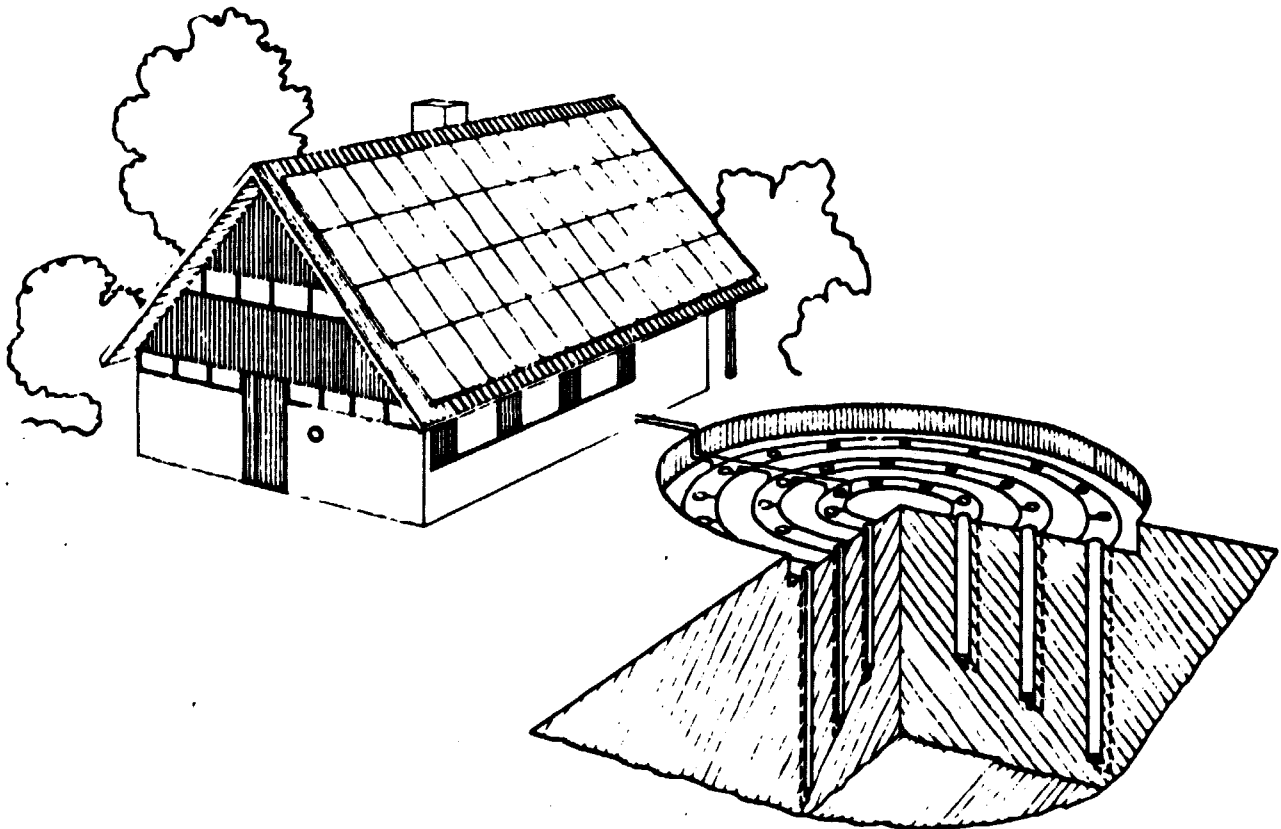
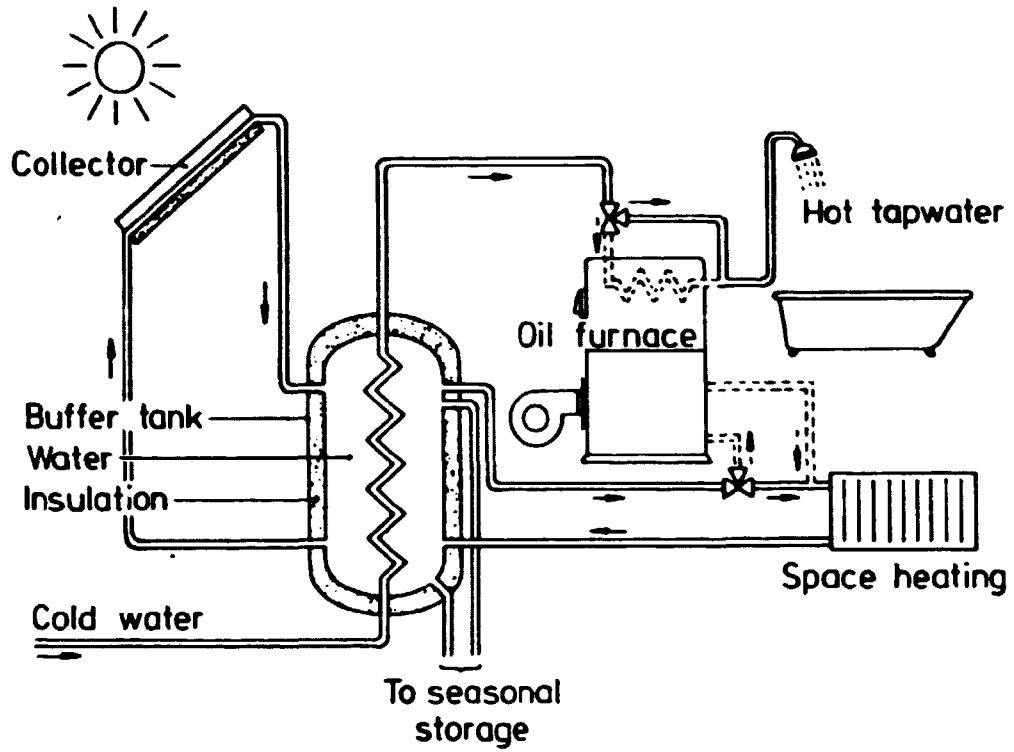

Fig. 1.1. Solar collector, seasonal storage and space heating/hot water system.



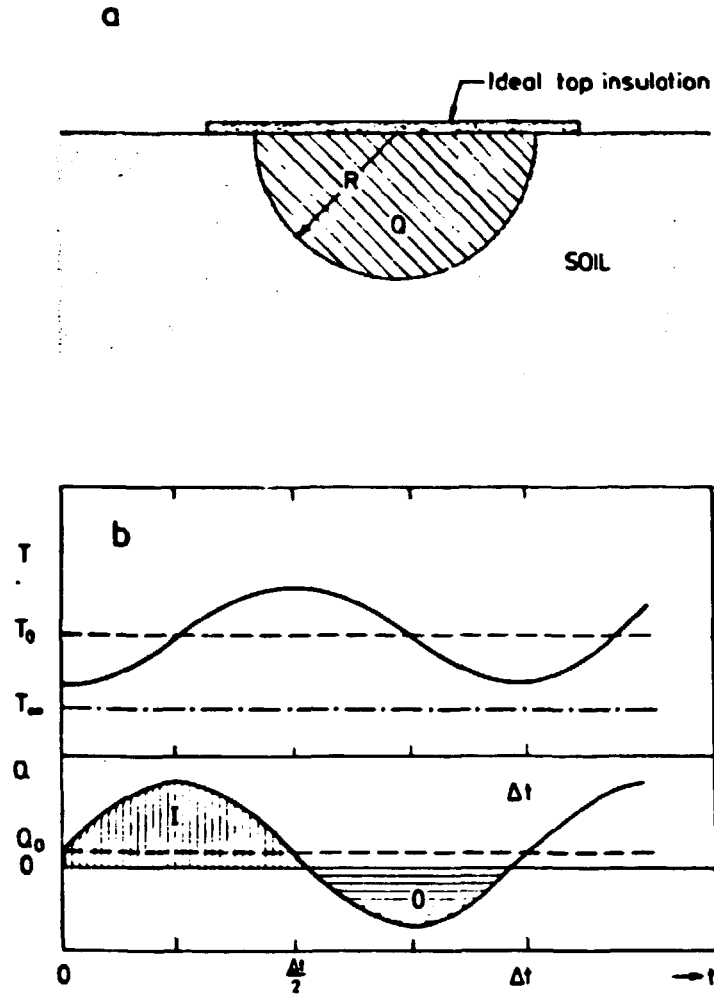

Fig. 1.2. Harmonic Analysis of Ideal Storage.

a. Geometry.

Storage: No top-heat loss.  
 No ground water.  
 Hemispherical.  
 Spherical symmetry.

Heat sources/drains (Q):

Homogenously distributed.  
 Operating simultaneously.

b. Variation of temperature T and source strength Q with time

$$Q(t) = Q_0 + Q_w \sin(\omega t) \quad (1)$$

$$T(r, t) = T_0(r, t) + T_w(r, t) \sin(\omega r - \phi(r)) \quad (2)$$

$$\omega = \frac{2\pi}{\Delta t}$$

The integrated heat input (I) and -output (O) during one cycle are indicated.  $T_\infty$  is the temperature at infinite distance.

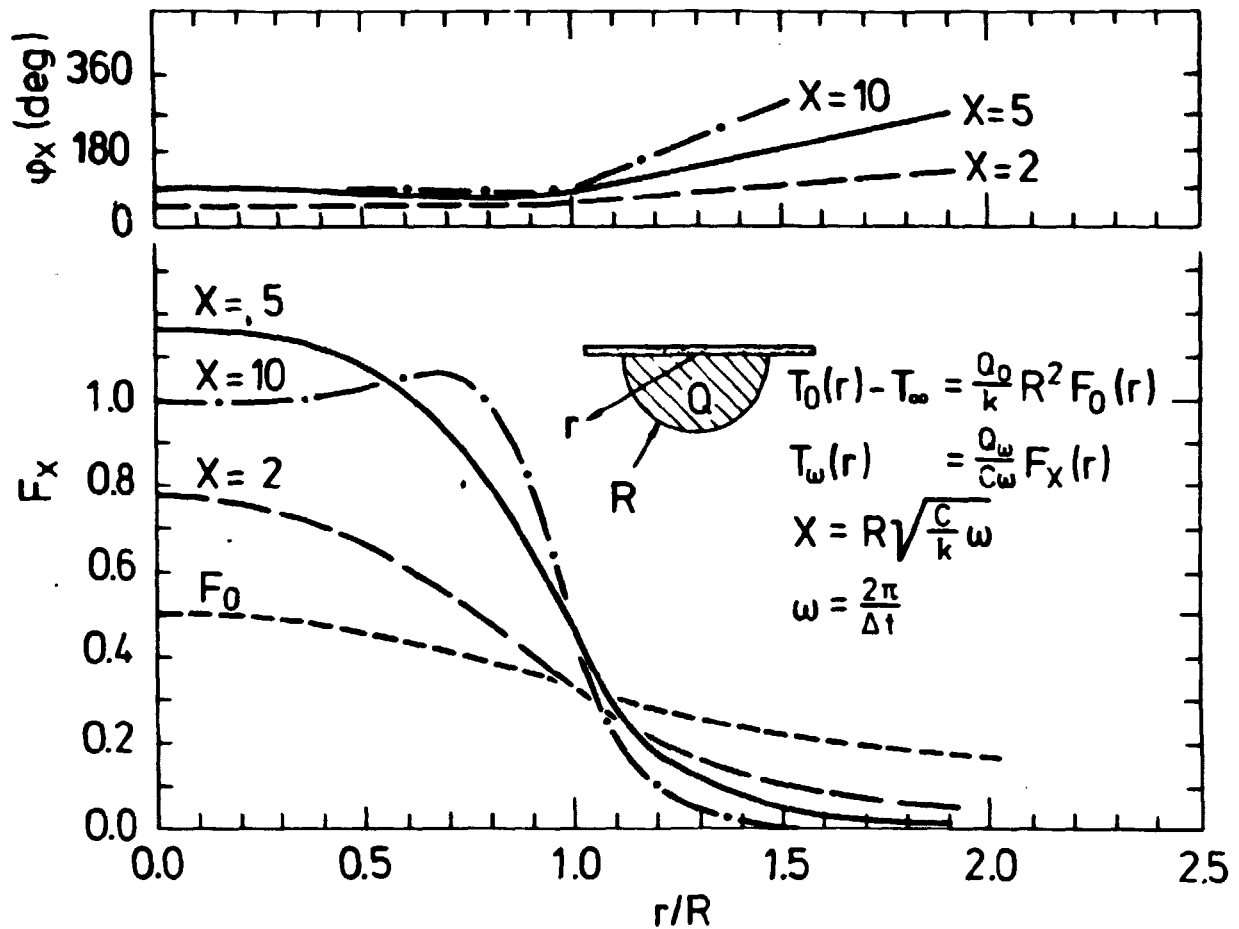

Fig. 1.3. Amplitude and phase of temperature as a function of relative distance from centre.

The dimensionless parameter  $X$  is the storage radius relative to the distance travelled by a "temperature wave" in time  $\Delta t$ .

$C$  is the volumetric heat capacity ( $\text{J}/\text{m}^3 \text{ } ^\circ\text{C}$ ) and  $k$  is the thermal conductivity ( $\text{W}/\text{m } ^\circ\text{C}$ ).

The heat loss per cycle is

$$L = \frac{4\pi}{3} R k (T_0(0) - T_\infty) \Delta t.$$

Ole Rathmann

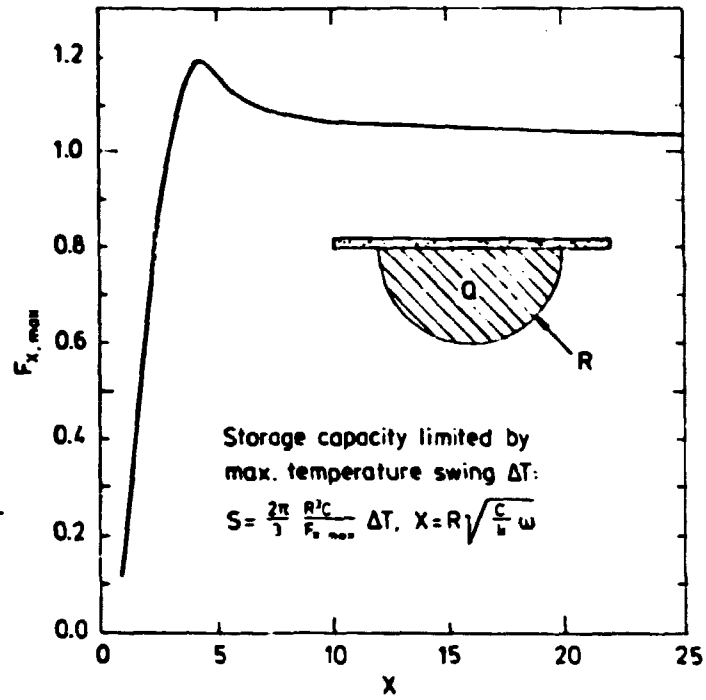

Fig. 1.4. Total storage capacity.

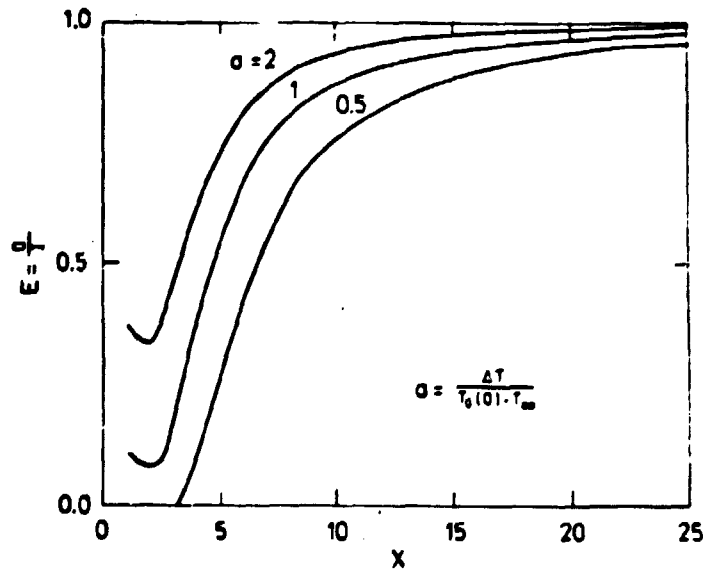

Fig. 1.5. Storage efficiency E.

$E = \frac{\text{(Integrated heat output)}}{\text{(Integrated heat input) per cycle.}}$

$T_0(0) - T_\infty$  is the difference between the time average centre temperature and the temperature at infinite distance (see Fig. 1.2.).

## Research on Energy Storage at Risø National Laboratory

### 1.4. Computer Simulation

In order to estimate the effect of removing the ideal assumptions various computer simulations of a ground heat storage were performed, two of which will be presented here.

The new effects taken into account were: (1) top heat loss, (2) presence of stagnant ground water, (3) discrete heat transfer pipes, and (4) non-sinusoidal time dependence of heat input/output.

The storage considered had a radius just at the lower limit found in Section 1.3 and the geometry is shown in Fig. 1.6. The spacing between the heat transfer pipes was chosen from simulations of systems with various spacings.

The storage was assumed to be connected with 10 family houses equipped with a total of 500 m<sup>2</sup> flat solar collectors and with a total heat consumption of 220 MWh. The heat output from the solar collectors was calculated on the basis of the Danish standard year. In the summer (charge) period the water in the heat transfer pipes was limited to 100°C and in the winter (recovery) period only water from the storage reservoir with temperature higher than 30°C was utilized.

The simulations were performed by means of a finite element heat conduction program assuming rotational symmetry around the vertical centreline. Effective heat transfer coefficients for the heat transfer pipes were used to account for the discreteness of these in the azimuthal direction. The temperature at an infinite distance was set at 7°C, independent of time.

The simulation was performed for two cases:

(a) one without and (b) one with ground water (stagnant) at 5.5 m below ground level. The soil properties are given in Table 1.1.

The resulting heat input/output during one year for case (a) is shown in Fig. 1.7. The simulation efficiency was found as 63% to be compared with the "ideal value" of 74%.

The non-ideal effects (1), (3), and (4) thus reduce the efficiency by about 10%.

When simulating case b the presence of even stagnant ground water in the lower half of the storage was found to reduce the efficiency further by 12% down to 51%. Apparently the higher thermal conductivity in the ground water region is not completely counteracted by the increase in the total thermal capacity.

When looking at the performance of the total solar energy system, the simulation of case a showed that during the winter months (November to March) 80% of the consumption was delivered by the solar energy system, or on a yearly basis 88%. For case b the corresponding figures are 72% and 83%.

### 1.5. Conclusion

The simulation results may be somewhat optimistic, as a large fraction

Ole Rathmann

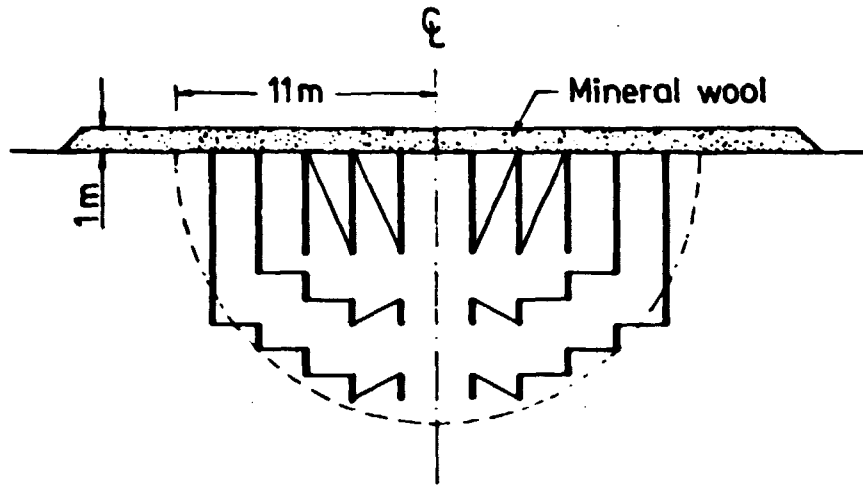

Fig. 1.6. Geometry of simulated ground heat storage. Heat transfer pipes are indicated by bold lines, connection pipes by thin lines.

The heat transfer pipes have a diameter of 5 cm and a spacing in each "circle" of 80 cm, giving a total length of 1280 m.

In the charge period the water flow direction is away from the centre, in the recovery period towards the centre.

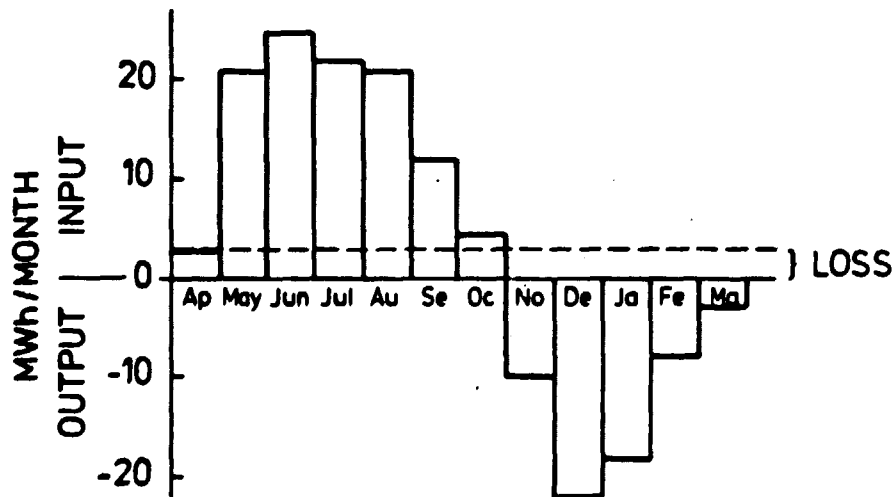

Fig. 1.7. Simulated heat input/output to and from the storage facility for case a. The resulting storage efficiency is  $E = 63\%$ .

Research on Energy Storage at Risø National Laboratory

Table 1.1. Soil Properties for the Simulations

---

Case a

All over .

Clay-sand-10 vol.% water

$$k = 0.9 \frac{W}{m^{\circ}C}$$

$$C = 1.7 \frac{MJ}{m^3 \circ C}$$

Case b

Above groundwater level

(5.5 m below ground level):

As case a.

Below groundwater level

Sands - 40 vol.% water

$$k = 2.2 \frac{W}{m^{\circ}C}$$

$$C = 2.9 \frac{MJ}{m^3 \circ C}$$

Simulation storage efficiency:

E = 63%

E = 51%

---

Jan Reffstrup and Jørgen Würtz

of the stored energy is recovered as hot water at only 30°C to 35°C; it is therefore difficult to utilize this energy unless very large heating areas - or a heat pump - are used in the space heating plant. On the other hand, the slight horizontal temperature stratification (increasing temperature towards the centre) may be utilized, as the outermost heat transfer pipes may be used solely for preheating hot tap water.

However, the presented results indicate that ground heat storage can work reasonably well provided that it has a sufficiently large size (corresponding to at least 10 family houses) and that the spacing between the heat transfer pipes is sufficiently small (0.5 to 1 m).

The great length of heat transfer piping is a serious problem in attempting to reduce costs. A real economic study is outside the scope of this work, however. Neither have the environmental effects of ground heat storage been considered, although they might be serious.

## 2. SEASONAL HEAT STORAGE IN AQUIFERS

Jan Reffstrup <sup>x)</sup> and Jørgen Würtz

### 2.1. General

Seasonal storage of hot water in natural aquifers (porous layers of gravel or sand) was proposed by Meyer and Todd (1973).

Such a storage method may be used to meet a part of the demand of a district heating system in the winter season by means of excess heat produced by combined heat and power plants in the summer season.

A rough estimate by Qvale (1976) indicates that 8% of the energy consumption (of a total of 40%) in the heating sector in Denmark can be saved by using plants with combined generation of heat and electricity rather than by individual oil furnaces and central power stations. Another 8 per cent may be saved by introducing energy storage. Moreover, most of the first 8 per cent will not be economically competitive without the use of seasonal energy storage.

Risø National Laboratory participates in a joint project on aquifer storage together with laboratories at the Technical University of Denmark and the Geological Survey of Denmark. The project includes geological exploration, construction and test run of a pilot plant and development of mathematical models.

### 2.2. Pilot Plant

The pilot plant is shown in conceptual form in Fig. 2.1. The height of the aquifer is approx. 30 m and the distance from the centre to one of the four outer relief wells is also approx. 30 m. The storage volume is thus approx. 100,000 m<sup>3</sup>. The test period is planned to be 2 years, so 2 cycles are covered. The periods for pumping up and

---

x) Laboratory for Energetics, Technical University of Denmark, DK-2800 Lyngby, Denmark.

Research on Energy Storage at Risø National Laboratory

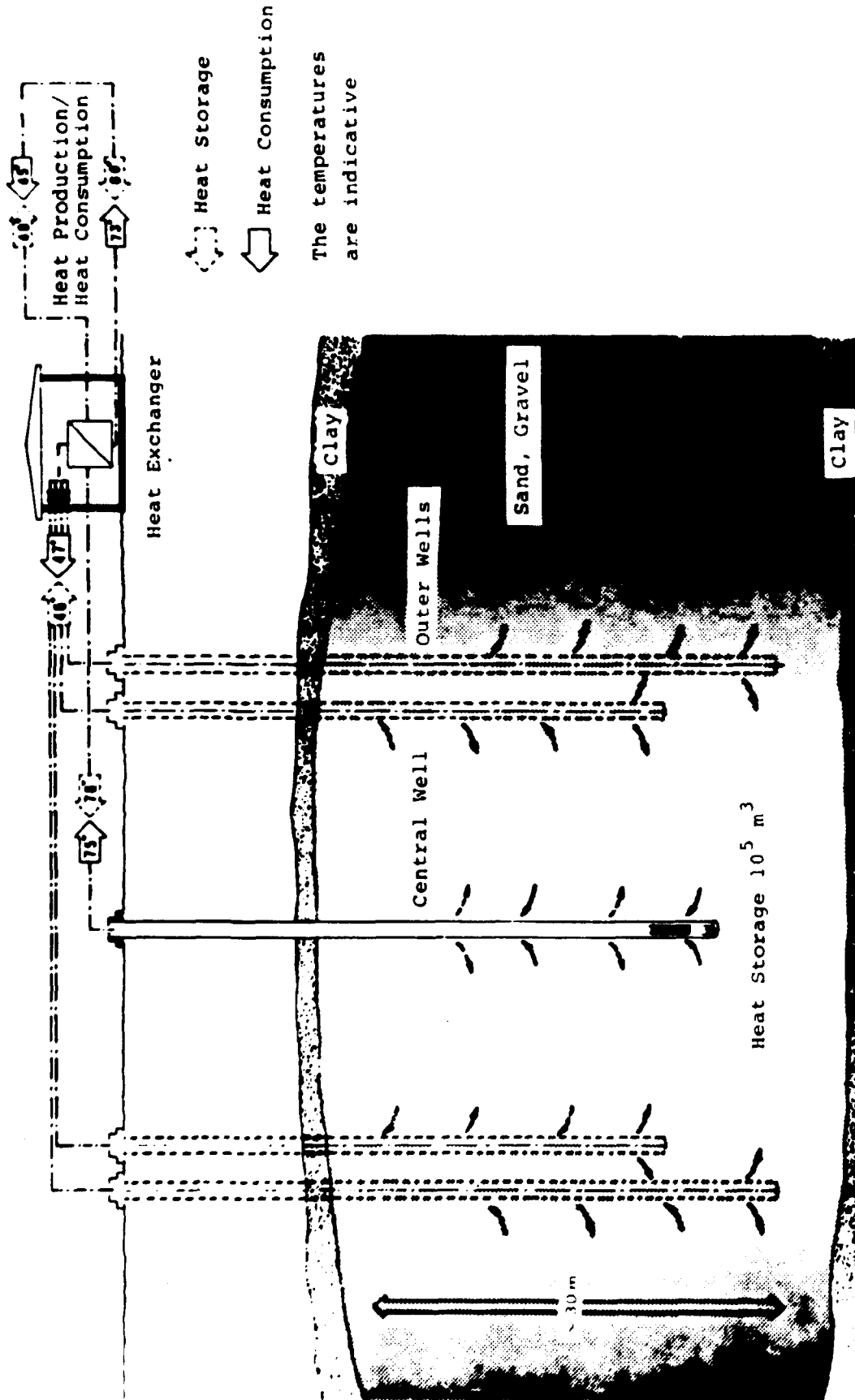

Fig. 2.1.



Jan Reffstrup and Jørgen Würtz

down are planned to be 4 months each. In the example shown, where the temperature from the combined heat and power plant is 80°C and the temperature of the water at the relief wells is 46°C, the efficiency in the second cycle is calculated to be 0.8. In the first cycle, where the initial temperature in the storage is approx. 8°C, the efficiency is approx. 0.36. The storage capacity is about 2 Tcal or approx. 10,000 GJ. The volumetric flow rate in the pumping periods is approx. 30 m<sup>3</sup>/h (8.33 l/sec) and the heat flow rate is about 1 MW.

The test period is planned to start in 1980.

2.3. Mathematical Models

Hitherto two 2-dimensional (or axisymmetrical 3-dimensional) models have been developed: A simplified model PORFLOW and a more detailed model D2AQ. It is planned to develop a (fully) 3-dimensional model on the basis of these two models. Due to the similarity in the heat and mass transfer in aquifers and in geothermal reservoirs, the models are also able to simulate the operations of a geothermal reservoir. In both models the finite element method has been applied for numerical solution of the governing equations.

2.3.1. D2AQ

The detailed model D2AQ has been developed at the Laboratory for Energetics at the Technical University of Denmark.

The three-dimensional axisymmetric numerical simulation model is based on the numerical solution of the coupled heat and fluid flow equations, which are (for nomenclature, see Section 2.5.):

Conservation of Mass

$$\frac{1}{r} \frac{\partial}{\partial r} (r \cdot \rho_f u_r) + \frac{\partial}{\partial z} (\rho_f u_z) = - \frac{\partial (\rho_f \cdot n)}{\partial t} \quad (1)$$

Conservation of Momentum (The Darcy Equations)

$$u_r = - \frac{k_r}{\mu_f} \frac{\partial p}{\partial r} \quad (2)$$

$$u_z = - \frac{k_z}{\mu_f} \left( \frac{\partial p}{\partial z} + \rho_f \cdot g \right) \quad (3)$$

Conservation of Energy

$$\begin{aligned} & \frac{1}{r} \frac{\partial}{\partial r} \left( r \cdot \lambda_e \frac{\partial T}{\partial r} \right) + \frac{\partial}{\partial z} \left( \lambda_e \frac{\partial T}{\partial z} \right) - \\ & \rho_f C_{vf} u_r \frac{\partial T}{\partial r} - \rho_f C_{vf} u_z \frac{\partial T}{\partial z} = \\ & (\rho_f C_{vf} n + \rho_s C_{vs} (1-n)) \frac{\partial T}{\partial t} \end{aligned} \quad (4)$$

Research on Energy Storage at Risø National Laboratory

Equations of State

$$\rho_f = \rho_f(T) \tag{5}$$

$$\mu_f = \mu_f(T) \tag{6}$$

plus initial and boundary conditions.

Substitution of the Darcy equation yields

$$\frac{1}{r} \frac{\partial}{\partial r} \left( -r \cdot \rho_f \cdot \frac{k_r}{\mu_f} \frac{\partial p}{\partial r} \right) + \frac{\partial}{\partial z} \left( -\rho_f \frac{k_z}{\mu_f} \left( \frac{\partial p}{\partial z} + \rho_f \cdot g \right) \right) = \frac{\partial(\rho_f n)}{\partial t} \tag{7}$$

Equations (2) to (7) form the mathematical basis for simulation of the coupled heat and fluid flow in aquifers.

Method of Solution

The numerical solution of the mathematical problem defined by equations (2) to (7) has been obtained by using the finite element method to solve the problem in space and the finite difference method to move the solution ahead in time.

The isoparametric quadrilateral element shown in Fig. 2.2 was used in the finite element solution, whereas the Crank-Nicholson finite difference method has been used for the time integration of the solution.

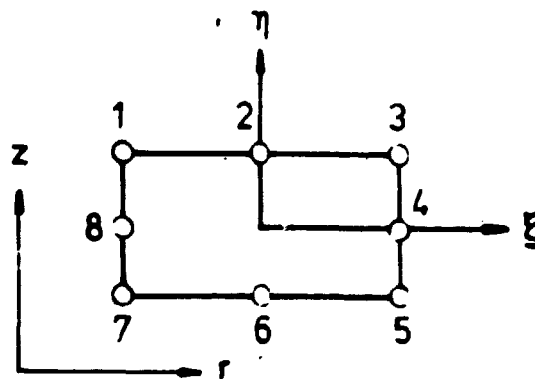

Fig. 2.2. Isoparametric quadrilateral element used in the finite element solution.

Jan Refstrup and Jørgen Würtz

Examples of Solution

In Figs. 2.3-2.5 examples of simulations with D2AQ are shown. The following input data have been used:

Injection rate	6 l/sec
Injection temperature	100°C
Initial temperature	10°C
Aquifer height	30 m
Aquifer radius	45 m
Permeability	5 Darcy = $5 \times 10^{-12} \text{ m}^2$

The temperature distribution is represented by isothermals for 10, 30, 50, 70, and 90 per cent of the difference between the injection and the initial temperature. The flow field is represented by velocity vectors multiplied by the radial position  $r$ . The variations of the mean temperatures at the central well (CW) and the outer relief wells (REW) are shown together with the variation in the pump head and the injection rate. From the figures it is seen that the thermal front capsizes so that the effective storage volume becomes significantly reduced. However, simulations made with the models show that the buoyancy-driven overshoot of the hot water can be reduced in several ways. An example will be given in the next section.

2.3.2. PORFLOW

In PORFLOW, which is developed at Risø National Laboratory, the temperature field is represented in a simplified way by a hot water zone and a cold water zone (cf. Rathmann (1978)). On this basis the water flow is calculated, and the front between the hot zone and the cold zone is traced throughout the storage cycle.

The pressure and flow equations (1)-(3) are solved by means of simple linear triangular elements. The energy equation (4) is reduced to a thermal front equation, which is solved by means of a one-dimensional finite element method. Because of these simplifications, PORFLOW is a faster working computer code than D2AQ. However, details such as the thermal front width cannot be calculated by means of PORFLOW. Typical results are shown on Fig. 2.6. Here is illustrated a method to compensate for the buoyancy-driven overshoot of the hot water.

2.4. References

C.F. Meyer and D.K. Todd, Conserving Energy with Heat Storage Wells. Environmental Science and Technology 7, 512-516 (1973).

O. Rathmann, PORFLOW: A Computer Finite Element Model for Aquifer Simulation, Risø National Laboratory, Department of Reactor Technology, SOL-7, 58 pp. (1978). Internal report.

B. Qvale, Seasonal Storage of Thermal Energy in Water in the Underground. 8 pp. Paper presented at the 1976 IECEC.

Research on Energy Storage at Risø National Laboratory

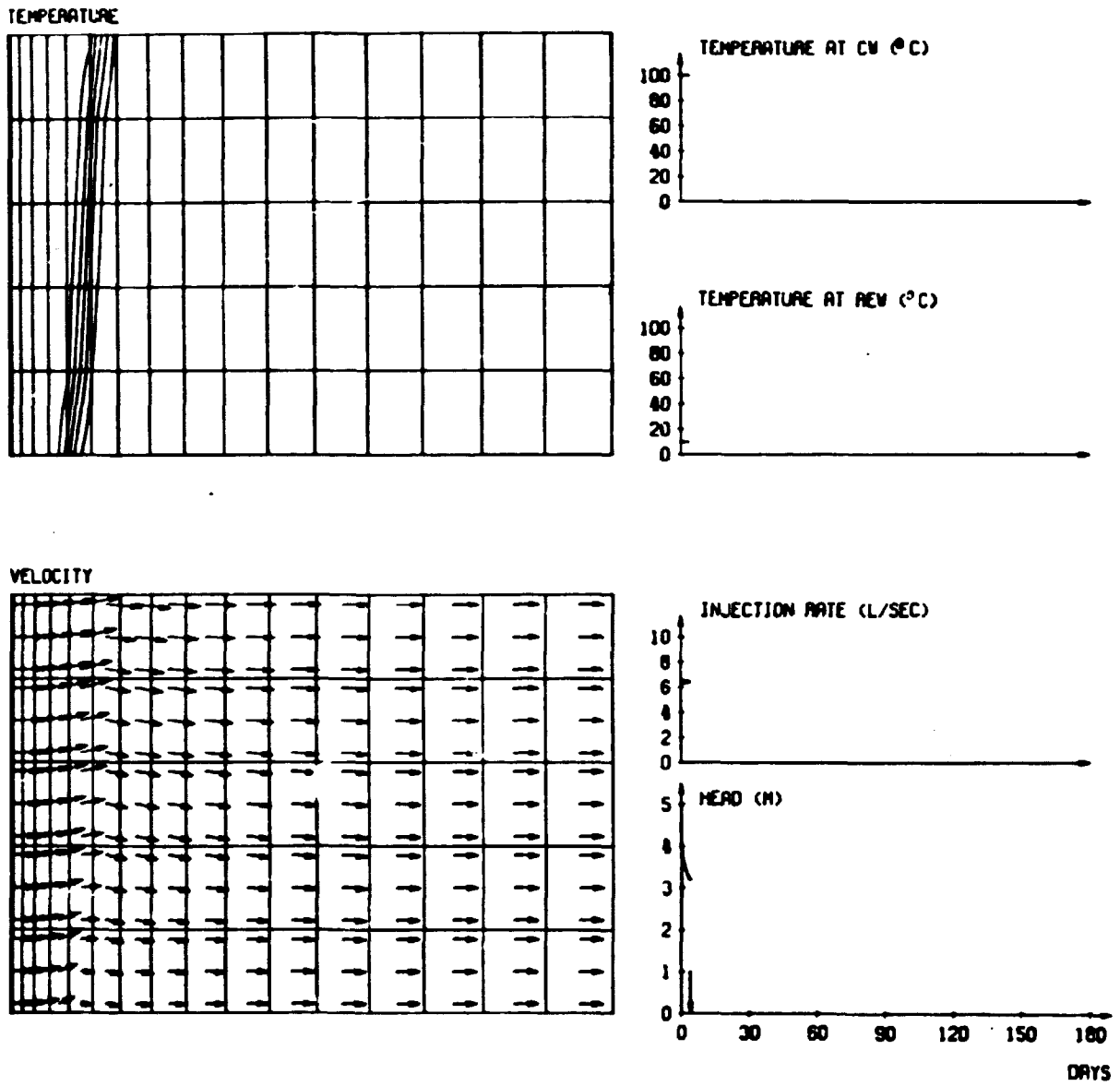

Fig. 2.3. Temperature distribution and flow field just after start-up. (5 days of operation.) Aquifer height 30 m, radius 45 m, permeability 5 Darcy.

Jan Refstrup and Jørgen Würtz

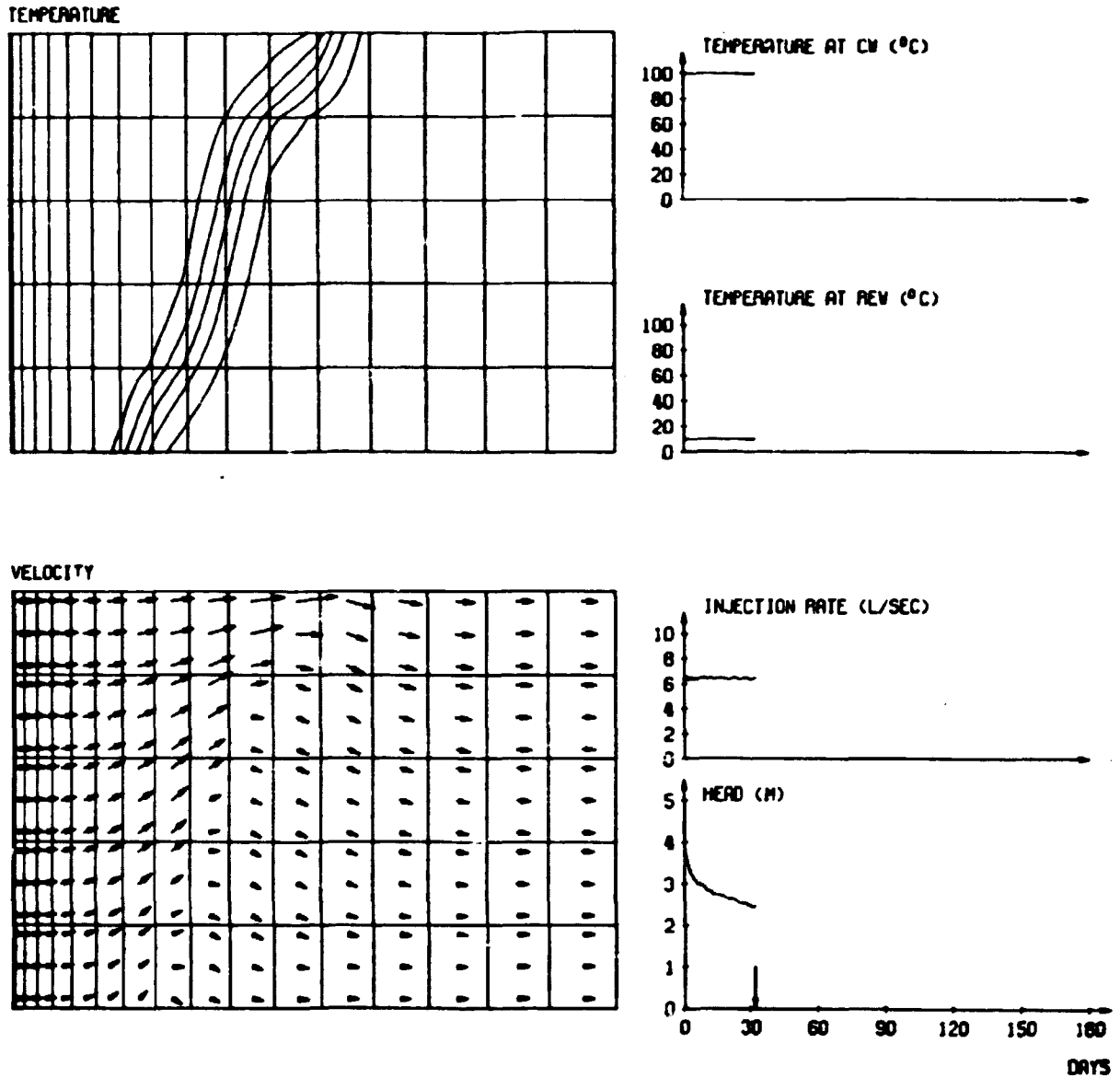

Fig. 2.4. Temperature distribution and flow field after 32 days of operation. Notice the buoyancy-driven overshoot of the hot injected water. The drop in pump head is due to the decrease in viscosity.

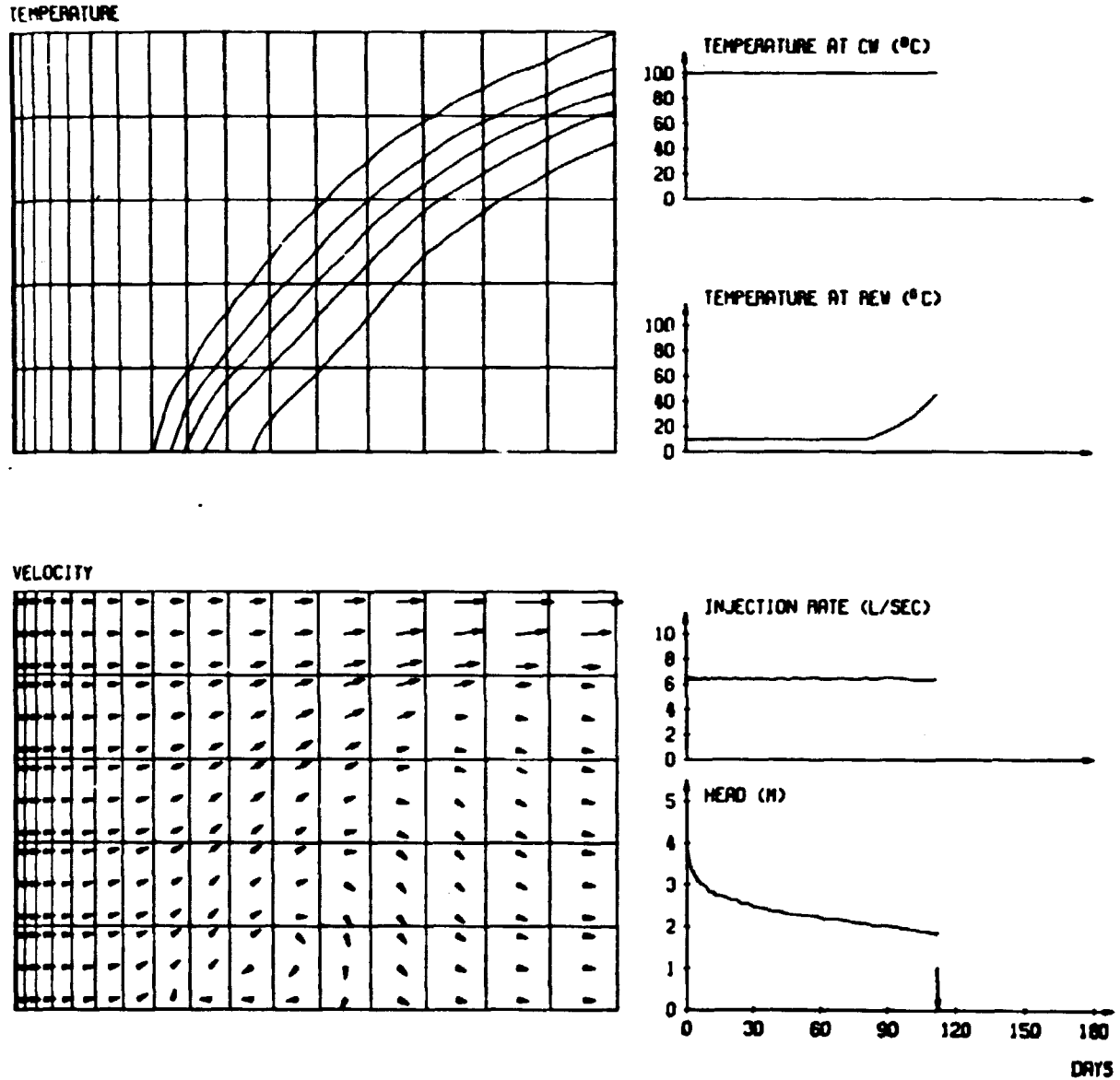

Fig. 2.5. Temperature distribution and flow field at the end of the pump-down period (110 days of operation.) The mean temperature at the outer wells (REW) has now become 40°C. It is seen that a significant part of the storage volume cannot be utilized because of the capsize of the thermal front.

Jan Reffstrup and Jørgen Würtz

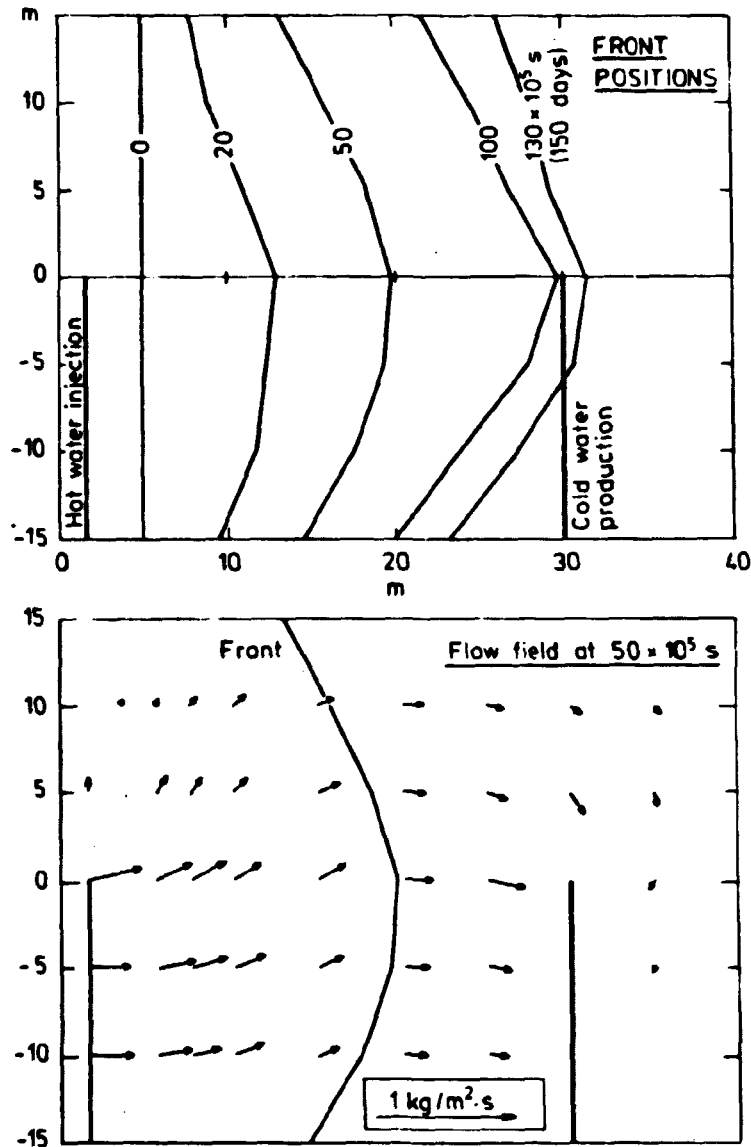

Fig. 2.6. Typical front movement during hot water injection. With a permeability of 2.6 Darcy =  $2.6 \times 10^{-12} \text{ m}^2$  the driving pressure is 18.1 kPa. The hot water is  $90^\circ\text{C}$  and the cold water is  $10^\circ\text{C}$ .

Upper half: The front position at different times is shown. The central well and the outer well are only open in the lower half of the aquifer to compensate for the buoyancy-driven overshoot of the hot water.

Lower half: The flow field at  $50 \times 10^5 \text{ s}$  is shown. The flow rate at a certain point is represented by a flow vector, starting at that point.

Research on Energy Storage at Risø National Laboratory

2.5. Nomenclature

$C_v$	$J/kg^{\circ}C$	Heat capacity at constant volume
$g$	$m/s^2$	Gravitational acceleration
$k$	$m^2$	Permeability
$n$	-	Porosity
$p$	$N/m^2$	Pressure
$r$	$m$	Radial coordinate
$t$	$s$	Time
$T$	$^{\circ}C$	Temperature
$u$	$m/s$	Velocity
$z$	$m$	Axial coordinate
$\lambda_e$	$W/m^{\circ}C$	Effective heat conductivity of water-saturated soil
$\mu$	$kg/ms$	Dynamic viscosity
$\rho$	$kg/m^3$	Density

Subscripts

$f$	Fluid (water)
$r$	Radial
$s$	Solid (soil)
$z$	Axial



Steen Krenk et al.

### 3. NATURAL GAS STORAGE IN SALT CAVERNS

Steen Krenk, Niels Saabye Ottosen, Knud Jensen  
and Ingv. Rasmussen

#### 3.1. Introduction

Due to the increasing storage demand for natural gas and oil products a large number of storage facilities, based upon leached caverns in underground salt formations, have been constructed during recent years in North America and Europe. Cavern volumes of 300,000 m<sup>3</sup> are not unusual in these plants. The underground storage concept has been preferred to surface tank farm storage for reasons of economy, safety and environmental protection.

In connection with the planning preparations for a future Danish gas transmission system Risø became involved in feasibility studies on a seasonal peakshaving storage facility in a salt dome by mid-1977, and the studies were terminated by end of 1978. The work was performed on a contractual basis for the stateowned company Dansk Olie & Naturgas A/S. Risø assumed the responsibility as a main consultant on the project and entered into close collaboration with the Danish Geological Survey and a series of sub-consultants at home and abroad to ensure access to supplementary know-how.

#### 3.2. Scope of Work

The feasibility study included:

- Planning and evaluation of additional field investigations and associated laboratory tests with a view to verify site feasibility in principle.
- A conceptual design study on a complete storage facility.
- Rock-mechanical safety investigations of the cavern concept.

The former activities are reviewed briefly and the latter in more detail in the following.

#### 3.3. Field Investigations and associated Laboratory Tests

Based upon geological pre-feasibility studies the location of Ll. Torup in Northern Jutland was selected as the tentative site for a future peak-shaving storage facility (Fig.3.1). An exploratory well was drilled during April-May 1978 to a final depth of 1600 m in the salt dome, and oriented drill cores were extracted from different depths for subsequent laboratory testing of the rock salt chemical and mechanical properties. The results from these investigations indicated that the salt dome would be feasible for gas storage applications, but further investigations would be required to provide complete verification.

#### 3.4. Conceptual Design Study

Development of the storage facility will include the establishment of a temporary leaching plant and a permanent gas storage and process

Research on Energy Storage at Risø National Laboratory

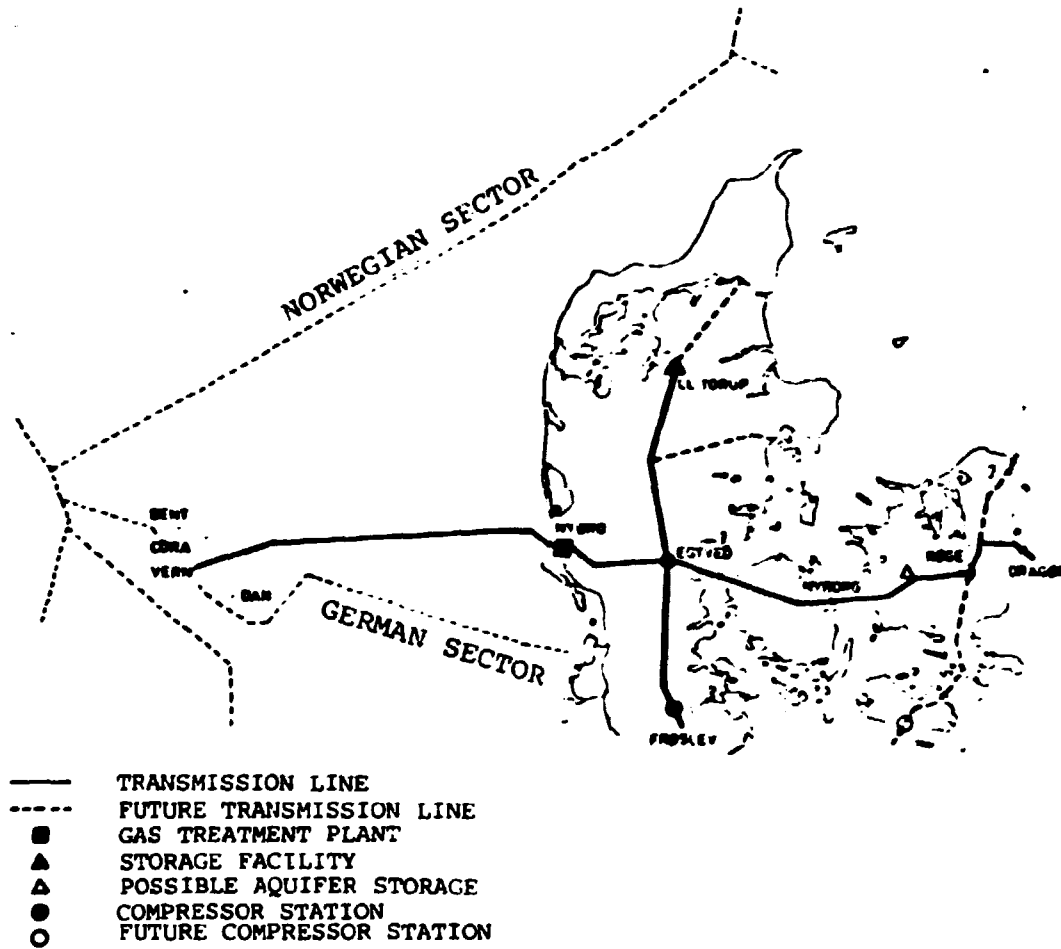

Fig. 3.1. Planned gas transmission lines and storage site.

Steen Krenk et al.

plant. The latter will comprise a number of underground cavities, each of 350,000 m<sup>3</sup> volume, and the associated surface plant equipment, such as: storage compressor plant, heating, drying and pressure reduction plant, and metering station. The surface plant will be of conventional design, independent of the location characteristics (Fig. 3.2.)

The conceptual study included technical and economic analysis of a wide range of potential storage development schemes, in which storage capacity and construction time were the main variables. Documentation from major European contractors was used as background information for the study.

### 3.5. Rock-mechanical Safety

As for normal engineering structures, the designing of a safe cavern facility includes 2 main steps: detailed studies and overall weighing of the results. The main safety aspects related to gas storage caverns are leak-tightness, mechanical strength under extreme loadings (max. and min. operating pressure occurring once a year), and long-term stability.

Caverns will typically be constructed at 1000-1500 m depths, where leak-tightness will be ensured by the high formation pressure (approx. 250 bar) and the plastic properties of the rock salt.

The plastic behaviour should also be taken into account in the analysis of the safety margin against failure in the cavern walls. Two essentially different conditions should be fulfilled: first, the overlying salt strata should not be fractured at maximum operating pressure, and secondly, the cavern walls should remain stable at the lowest occurring gas pressure. The former condition is fulfilled by restricting the maximum pressure to a level essentially below the total weight of the overlying strata, and by special design precautions for the casing assembly.

Design considerations related to lower gas pressures must include both the annual minimum operating gas pressure and also potential depressurization of the cavern to atmospheric pressure in case of accidents. It is therefore desirable to design the cavern for short-term stability under atmospheric pressure.

Two types of stress analysis methods have been applied for the investigations of the low-pressure situation: an analytical approach based upon simplified assumptions concerning cavity geometry and material behaviour, and a nonlinear finite element approach using the AXISYM computer code (Fig. 3.3.). The results from the two methods showed good agreement in the critical area at cavern mid-height. Selected results from the finite element analysis are illustrated in Fig. 3.4., which shows the extent of plastic areas round the maximum operating, minimum operating and atmospheric pressures, respectively.

Long-term cavern stability is related to a progressive volume reduction, which may have a gradually increasing impact upon overall operating economy, and may also lead to potential subsidence at surface level. Only the latter aspect is safety-related.

Research on Energy Storage at Risø National Laboratory

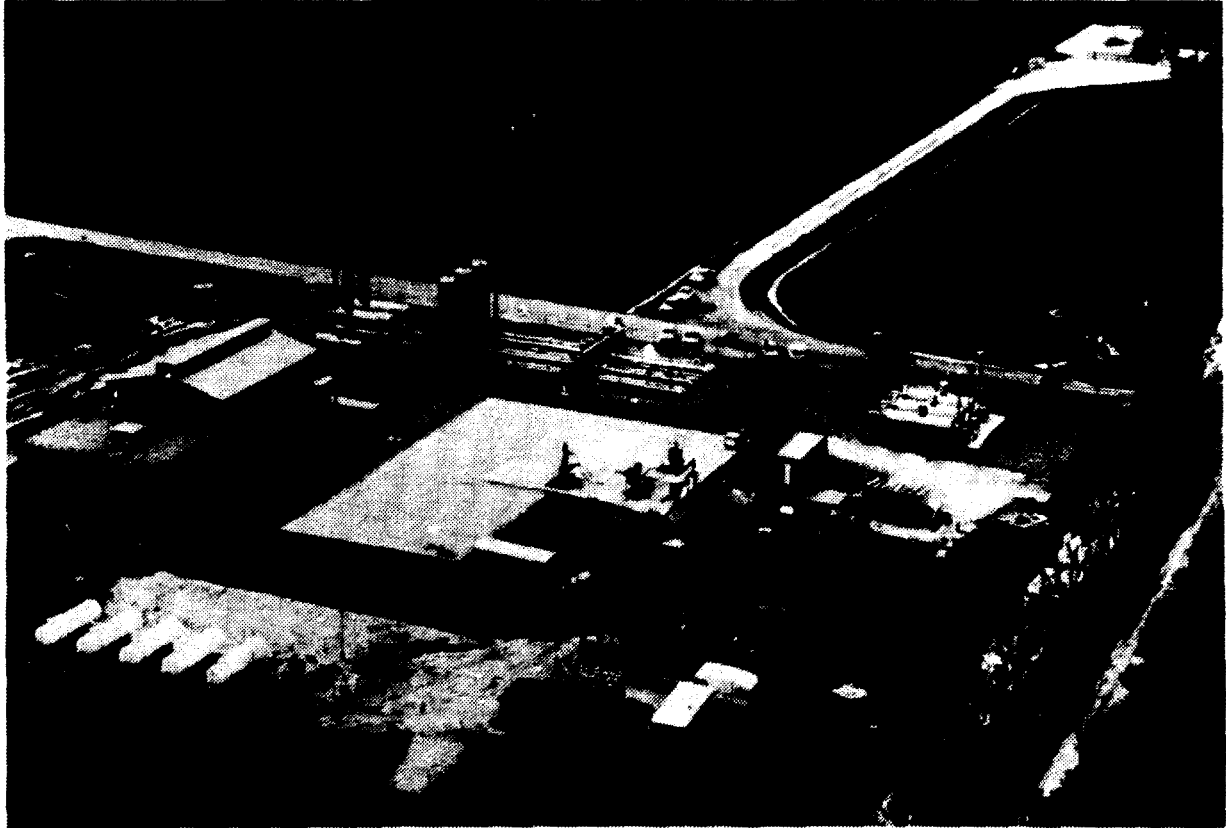

Fig. 3.2. Natural gas storage plant with underground storage in Northwest Germany.

Steen Krenk et al.

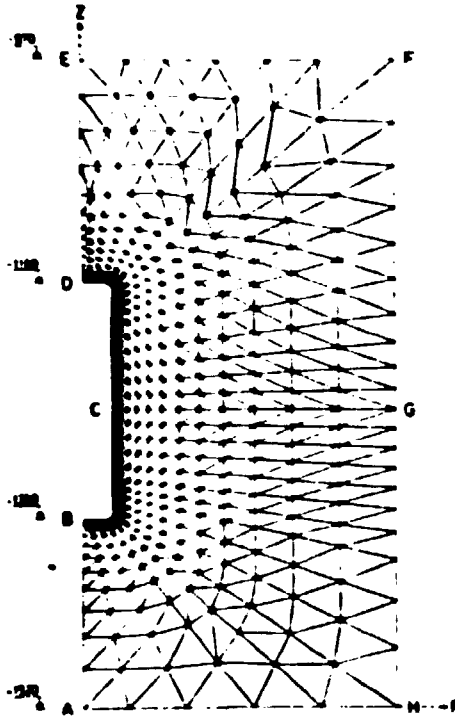

Fig. 3.3. AXISYM-mesh of idealized cavern geometry.

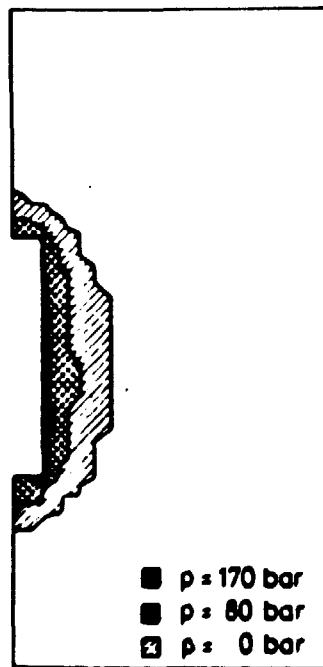

Fig. 3.4. Areas of nonlinear material behaviour around cavern.

## Research on Energy Storage at Risø National Laboratory

### 3.6. Future Activities

At present Risø is involved in subsequent stages of the storage project, including both general engineering activities and also more detailed studies on rock-mechanical safety.

### 3.7. References

- S. Krenk, Internally Pressurized Spherical and Cylindrical Cavities in Rock Salt, Int. J. Rock Mech. Min. Sci. & Geomech. Abstr. 15, 219-224 (1978).
- Niels Saabye Ottosen, A Constitutive Model for Rock Salt, Risø Report No. 383 (August 1978).
- N.S. Ottosen & S. Krenk, Nonlinear Analysis of Cavities in Rock Salt, Int. J. Rock Mech. Mech. Min. Sci. & Geomech. Abstr. 16, 245-252 (1979).

## 4. ENERGY STORAGE BASED UPON METAL-HYDROGEN SYSTEMS

Bjørn Vigeholm

### 4.1. General

It is well-known that certain metals and inter-metallic compounds react with hydrogen to form metal hydrides. These reactions are exothermic and may be reversed by addition of heat:



Three systems are at present under serious considerations for energy storage purposes:

FeTi and alloys ( $\text{Fe}_{1-x}\text{TiMe}_x$ ; Me: Mn, Ni, Cu)

AB<sub>5</sub> intermetallic compounds (A: Rare earth metals or substitutes  
B: Group VIII, e.g. LaNi<sub>5</sub>,  
CaCo<sub>5</sub>)

Mg and alloys, e.g. MgNi<sub>x</sub>; MgCu<sub>x</sub>.

Of the three systems Mg is far the least investigated, and in general considered to have the least probability of becoming a practicable hydrogen carrier.

Very roughly outlined, the differences between the three systems are:

- FeTiH<sub>2</sub>:
- 2% by weight hydrogen,
  - Low working temperature for the applicable dissociation pressure range 1-20 bar,
  - Reasonably high reaction rate,
  - Low heat of formation,
  - Relatively expensive, resources limited,

Bjørn Vigeholm

- $\text{LaNi}_5\text{H}_7$ : - 1.5% by weight hydrogen,  
- Reasonably low working temperature  
- High reaction rate,  
- High heat of formation,  
- Expensive, resources limited,
- $\text{MgH}_2$ : - 7.6% by weight hydrogen,  
- High working temperature,  $> 250^\circ\text{C}$ ,  
- Reaction rate, not well known,  
- High heat of formation,  
- Inexpensive, abundant.

At Risø National Laboratory we have chosen to investigate the Mg-MgH<sub>2</sub> system from the following considerations:

- 1) If a medium for energy storage shall have any impact it must be based upon a low cost material which can be supplied universally. The hydrogen concentration by weight in MgH<sub>2</sub> is 4-5 times that of FeTiH<sub>2</sub> and LaNi<sub>5</sub>H<sub>7</sub>. Furthermore magnesium is by far the cheapest material; so with the actual marked prices, hydrogen storage per unit price is approximately 12 times as great in Mg as in FeTi and compared to the LaNi<sub>5</sub> group even 40-100 times as great.
- 2) The high enthalpy figure, -75 kJ/mol H<sub>2</sub> (upper heat of combustion, 285 kJ/mol H<sub>2</sub>) is not necessarily a disadvantage, as it permits heat storage applications.
- 3) For storing low grade waste heat the working temperature of Mg-MgH<sub>2</sub> is too high, but a hybrid system with one of the other hydride systems as a pick-up and Mg as main storage is quite conceivable.

#### 4.2. Results

MgH<sub>2</sub> was not synthesized from its element until 1951 and only under extreme conditions: 400 bar, 500°C. Probably because of the early reported difficulties, relatively little literature is available.

Most researches claim:

- Slow hydriding and dehydriding rates,
- Difficulties in activating the metal,
- Hydrogen concentrations substantially below the stoichiometric composition.
- High susceptibility to poisoning from many contaminants, e.g. O, S, hydrocarbons.
- Reduced uptake after even a small number of sorption cycles.

Upon this background it is somewhat surprising that our results are contradictory on almost all points, cf. Fig. 4.1.:

We find the reaction rates to be comparable to those found in FeTi. No need for special activation measures, no deviation from stoichiometric compositions.

No adverse effect of exposure to air, i.e. no apparent poisoning

Research on Energy Storage at Risø National Laboratory

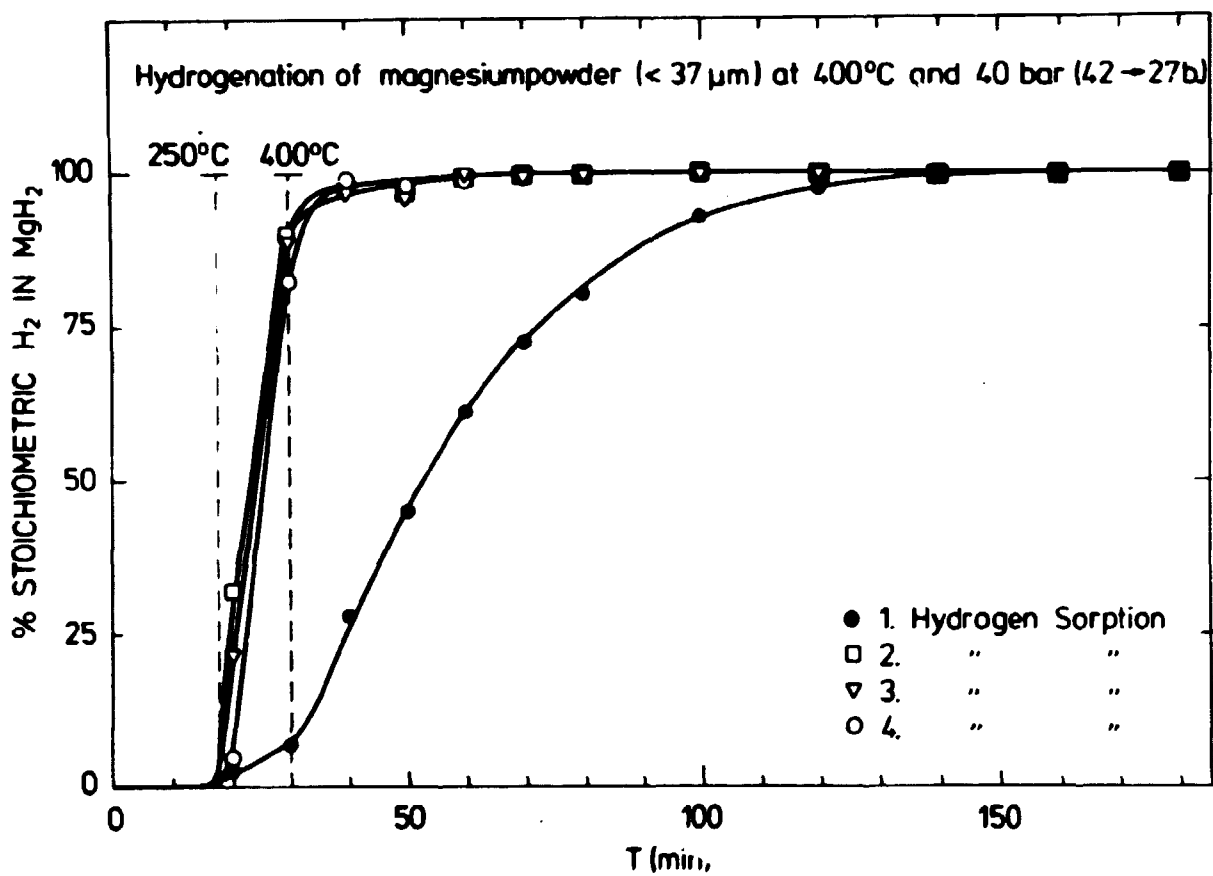

Fig. 4.1. Hydrogen sorption in Mg at 400°C, 400 bar  
1 to 4 denotes a sequence of hydrogenations  
of the same sample.  
The nominal 400°C reached in approximately  
35 min. Starting temperature 22-24°C.



Bjørn Vigeholm

by oxygen.

Increased reaction rate with cycling.

It should be pointed out that our experiments have so far been very crude. They have been carried out in preliminary experimental setups, which do not permit precise statements concerning time measurements as slow heating and cooling was involved.

That the above statements are qualitatively correct has been checked in several ways. Different Mg powders from different suppliers were used, the absorbed amount of hydrogen was measured by pressure changes in a known volume as well as gravimetrically, chemical analyses were done on the material before and after hydrogen sorption, etc.

#### 4.3. Programme

The present programme contains

- Evaluation of kinetic data for the sorption cycle (in newly designed facilities)
- Investigation of mechanically relevant properties, e.g. packing behaviour,
- Construction of a laboratory scale hydrogen storage unit.
- Systematic investigation of the effect of possible contaminants in practical application.
- Investigation of the potentials of a heat storage system. Preliminary calculations indicate that Mg might be competitive with water tanks, even disregarding the lack of heat loss during storage of the hydride system.

#### 4.4. Impact on Energy Supply

Although the possible impact of the Mg-H system is closely related to the general fate of the predicted hydrogen economy we feel that the system has a number of potentials, e.g. in waste heat recovery.

With the 12 times lower price (compared to FeTi) and the high safety in handling (compared to gaseous or liquid hydrogen), magnesium hydride is quite attractive as a means of making hydrogen available for many uses.

Research on Energy Storage at Risø National Laboratory

Table 4.1

Hydrogen and Energy Density of Different Hydrogen Storages

	Hydrogen concentration		Energy density x)	
	% by weight	g/ml	kJ/g	kJ/ml
MgH <sub>2</sub>	7.6	0.13	11	19
FeTiH <sub>2</sub>	1.9	0.12	2.7	17
LaNi <sub>5</sub> H <sub>7</sub>	1.4	0.13	2.1	18
H <sub>2</sub> liquid	100	0.07	142	10
H <sub>2</sub> , gas 200 atm.	100	0.016	142	2.5

x) upper heat of combustion.

Table 4.2

Energy Density Comparison  
Automotive Power Sources

Power Source	Energy Density whr/kg	MJ/kg	Conversion Efficiency %	Net whr/kg	MJ/kg
Pb/acid battery					
Present	30	0.11	70	21.0	0.08
Advanced	50	0.18	70	35.0	0.13
Li/MS Battery	150	0.5	70	105	0.40
FeTiH <sub>1.7</sub> <sup>a,b</sup>	516 <sup>c</sup>	1.9	30	154	0.55
Mg <sub>2</sub> NiH <sub>4</sub> <sup>a,b</sup>	1121 <sup>c</sup>	4.0	30	336	1.2
MgH <sub>2</sub> (10% Ni) <sup>a,b</sup>	2555 <sup>c</sup>	9.2	30	767	2.8
Gasoline <sup>a</sup>	12880 <sup>c</sup>	46	23	2962	10.7

a No allowance for container weight

b Based on available hydrogen  
i.e. FeTiH<sub>1.7</sub> → FeTiH<sub>0.1</sub>

Mg<sub>2</sub>NiH<sub>4</sub> → Mg<sub>2</sub>NiH<sub>0.3</sub>

MgH<sub>2</sub> → MgH<sub>0.05</sub>

c Based on lower heat of combustion

Knud Ladekarl Thomsen

## 5. STRATIFIED STORAGE FOR SOLAR HEATING SYSTEMS

Knud Ladekarl Thomsen

In a water heat storage tank for solar heating systems the conditions are usually so quiet that some temperature stratification will occur spontaneously. This tendency is regarded as an advantage because any mixing in the tank of hot and cold water will cause a loss in collector efficiency. This is due to increased collector losses if the relatively cold bottom water determining the collector inlet temperature is mixed with hot water from a higher level in the tank.

Some investigations regarding optimal utilization of temperature stratification have been made. Obviously, measures should be taken to ensure that water heated in the solar collector is returned to the storage tank at the level where the water temperature corresponds to the collector outlet temperature. Similarly the outlet from the storage to hot water and space heating should not be taken from an unnecessarily high temperature level; when returned to the tank after being cooled, the appropriate input level is that where the temperature fits. If a heat exchanger is inserted between the collector and the tank, a separate exchanger is preferable from the stratification point of view, because a simple immersion type exchanger inevitably causes convective mixing in the tank.

All these efforts to maintain optimal stratification may not seem worthwhile in the usual mode of collector operation, where the flow rate is high. However, fully stratified operation of the storage facility allows one to reduce the collector flow rate without any penalty on the system efficiency. This can be shown theoretically on the basis of the Hottel-Bliss-Whillier equation. Thus stratification gives a degree of freedom which may result in a better utilization of the unpredictable sunlight.

For instance, starting with a cold storage in the morning, useful temperatures can quickly be attained in the top of the tank, if the collector flow is low, producing a high temperature increase in the collector. As another example, after a sunny day, the late afternoon sunshine can be utilized with better efficiency here than in connection with mixed storage, because the lower portion of the tank may still be relatively cool.

As seen from the consideration above there may be some advantages in a stratified operation, but the phenomena are interrelated in a complicated manner, which necessitates computer calculations which deal with different operating strategies. We are investigating the phenomena and hope to reach a conclusion concerning these matters in the not too distant future.

2191

Rise - M -

<p>Title and author(s)</p> <p>RESEARCH ON ENERGY STORAGE AT RISØ NATIONAL LABORATORY</p> <p>K. Jensen<sup>a)</sup>, S. Krenk<sup>a)</sup>, N.S. Ottosen<sup>a)</sup>, I. Rasmussen<sup>a)</sup>, O. Rathmann<sup>b)</sup>, J. Reffstrup<sup>d)</sup>, K.L. Thomsen<sup>b)</sup>, B. Vigeholm<sup>c)</sup>, and J. Würtz<sup>b)</sup></p>	<p>Date September 1979</p> <p>Department or group Reactor Technology</p> <p>Group's own registration number(s)</p>
<p>34 pages + 3 tables + 18 illustrations</p>	
<p>Abstract</p> <p>This paper was presented at the International Assembly on Energy Storage held from May 27 to June 1, 1979 in Dubrovnik, Yugoslavia.</p> <p>It contains a review of some of the research projects on energy storage at Risø National Laboratory. Some of the already obtained results are presented together with planned activities for the next few years.</p> <p>Some of the projects are carried out in close cooperation with the Laboratory for Energetics at the Technical University of Denmark and the Geological Survey of Denmark.</p> <p>_____</p> <p>a) Engineering Department b) Department of Reactor Technology c) Metallurgy Department d) Laboratory of Energetics, Technical University of Denmark, DK 2800 Lyngby, Denmark.</p> <p>Available on request from Risø Library, Risø National Laboratory (Risø Bibliotek), Forsøgsanlæg Risø), DK-4000 Roskilde, Denmark Telephone: (03) 37 12 12, ext. 2262. Telex: 43116</p>	<p>Copies to</p> <p>Authors (100) Library (100)</p>