



Notes on human performance analysis

Hollnagel, E.; Pedersen, O.M.; Rasmussen, Jens

Publication date:
1981

Document Version
Publisher's PDF, also known as Version of record

[Link back to DTU Orbit](#)

Citation (APA):
Hollnagel, E., Pedersen, O. M., & Rasmussen, J. (1981). Notes on human performance analysis. (Risø-M; No. 2285).

DTU Library

Technical Information Center of Denmark

General rights

Copyright and moral rights for the publications made accessible in the public portal are retained by the authors and/or other copyright owners and it is a condition of accessing publications that users recognise and abide by the legal requirements associated with these rights.

- Users may download and print one copy of any publication from the public portal for the purpose of private study or research.
- You may not further distribute the material or use it for any profit-making activity or commercial gain
- You may freely distribute the URL identifying the publication in the public portal

If you believe that this document breaches copyright please contact us providing details, and we will remove access to the work immediately and investigate your claim.

2285

Risø - M -

<p>Title and author(s)</p> <p>Notes on human performance analysis</p> <p>E. Hollnagel, O. M. Pedersen and J. Rasmussen</p>	<p>Date June 1981</p>
<p>pages + tables + illustrations</p>	<p>Department or group</p> <p>Electronics</p> <p>Group's own registration number(s)</p> <p>R-1-81</p> <p>EH-OMP-JR/bs</p>

Abstract

This paper attempts an integration of the various ways and means by which human performance in nuclear environments - real or simulated - can be observed, recorded, and analysed. It is based partly on the work carried out by Risø, alone or as a participant in several international projects, but does, of course, also draw on the general state-of-the-art in the field.

The first section describes a categorization of various data sources and data types. A distinction is made between four primary sources: (1) Routine Plant Event Reports, (2) Special Post Incident Plant Interviews, (3) Training Simulators, and (4) Research Simulators. For each source the typical purposes and data types are discussed. Next a description is given of a generalized analysis scheme, which connects the various levels of analysis - from the raw data to the competence description. It is further discussed how the results from the different levels of analysis may be used for various purposes.

The following four main sections give a detailed description of how the performance analysis takes place for each of the four data sources. This is based on an analysis of Licencee Event Reports and a taxonomy developed for an OECD/CSNI working group; an American study of critical operator decisions based on post-incident analysis in depth of emergency events; a proposed project for comparison of performance in training simulators, based on a pilot investigation of the current practice; and a Scandinavian project for control room design which included a series of experiments at a research simulator, for which a specific experimental method was developed. The descriptions aim at showing the similarities among the analyses in the different cases, and how they can be related to a common conceptual framework.

The report ends with a discussion of the applicability of the various methods of observation, registration, and analysis to specific situations. Throughout the report it is emphasized that it is highly useful to try to cooperate the knowledge and experience which are gained from different contexts into a coherent picture of how nuclear reactor operators perform under varying circumstances. This report bears witness to the feasibility of the approach, and also indicates the direction which further development should take.

Available on request from Risø Library, Risø National Laboratory (Risø Bibliotek), Forsøgsanlæg Risø DK-4000 Roskilde, Denmark Telephone: (03) 37 12 12, ext. 2262. Telex: 43116

RISØ-M-2285

NOTES ON HUMAN PERFORMANCE ANALYSIS

E. Hollnagel, O. M. Pedersen and J. Rasmussen

Abstract. This paper contains a framework for the integration of observation and analysis of human performance in nuclear environments - real or simulated. It identifies four main sources of data, and describes the characteristic data types and methods of analysis for each source in relation to a common conceptual background. The general conclusion is that it is highly useful to combine the knowledge and experience from different contexts into a coherent picture of how nuclear operators perform under varying circumstances.

INIS Descriptors. ACCIDENTS; BEHAVIOUR; CONTROL ROOMS; DATA ACQUISITION; EDUCATION; ERRORS; MAN-MACHINE SYSTEMS; NUCLEAR POWER PLANTS; PERFORMANCE; REACTOR OPERATORS; REACTORS SIMULATORS

UDC 621.039.56 : 65.015.11

RISØ BIBLIOTEK

5100019079212



June 1981

Risø National Laboratory, DK 4000 Roskilde, Denmark

ISBN 87-550-0756-2

ISSN 0418-6435

Risø Repro 1981

TABLE OF CONTENTS

	Page
INTRODUCTION	7
Data Sources and Data Types	7
Plant events	7
Plant interviews	7
Training simulators	8
Research simulators	8
Data Analysis	9
Raw data	10
Intermediate data format	10
Analysed event data	12
Conceptual descriptions	12
Competence descriptions	13
 THE APPLICATION OF RESULTS FROM VARIOUS LEVELS OF ANALYSIS	 15
 ANALYSIS OF ROUTINE EVENT REPORTS	 20
Internal Human Malfunction	23
Mechanisms of Human Malfunction	26
Causes of Human Malfunction and Performance Shaping Factors	 31
 ANALYSIS OF COMPLEX INCIDENTS BASED ON IN-PLANT INTERVIEWS	 32
Available information	37
Event signaled	37
Knowledge and/or belief state components	37
Intention	38
Expectations	38
Decision/action	38
Sources for decisions/actions	38
Immediate feedback	39
Comments	39
Comments	39

ANALYSIS OF TRAINING SIMULATOR PERFORMANCE	45
The Method	47
Selection of the events to study	47
Description of transient and related operator procedures	47
Training session	48
Replay and debriefing	48
Analysis	48
Feedback	53
Concluding analysis	53
Comments	53
ANALYSIS OF RESEARCH SIMULATOR PERFORMANCE	54
The Method	55
Selection of the event to study	55
Selection of the subjects	56
Description of the incident and the expected operator performance	57
Actual experiment	58
Preliminary analysis	58
Experimental replay	59
Final analysis	59
ANALYSIS TO IDENTIFY PROTOTYPICAL PERFORMANCE PATTERNS AND RELATED COMPETENCE CONTENT	65
CONCLUSION	78
REFERENCES	84

INTRODUCTION

There is a growing need for human performance data for design of man-machine interface systems based on new control room technology and for quantification and prediction of human performance in high risk systems and situations.

Several different sources of data are at hand, each of them with particular features with respect to problems of data collection and the quality of data which it is practically feasible to collect. The present report is an attempt to summarize the features of data collection and analysis as we have met them during a number of cases. The purposes are (1) to provide a basis for the coordination of future analyses and (2) to interrelate results from different sources.

Data Sources and Data Types

The data sources may belong to either of two categories: nuclear power plants or just plants, and simulators of nuclear reactors. Within each of these categories one may distinguish several different types. In the present note the following distinct sources of data will be considered.

- (1) Routine event reports or plant events. Examples of these are the Licencee Event Reports (LER) which are standardized reports about incidents in US nuclear power plants. The raw data in plant reports are normally checklists and free text comments and concerned only with the incident in question. The plant event reports are, of course, only concerned with abnormal events or failure situations.
- (2) Special human factors post incident studies of events or plant interviews. These represent a more thoroughgoing analysis of an incident by human factors (HF) specialists and technical specialists. The raw data include, in addition to the raw data from the plant events, interviews with plant personnel, expert assessment of critical parts

of the incident, special checklists, computer logs and time line printouts, etc. The plant interviews are, similarly to the plant events, only concerned with abnormal events or failure situations.

- (3) Training simulators. Training simulators are designed to train operators in a high-fidelity simulation of a work situation. They normally include a detailed replica of the control room in the corresponding nuclear plant as well as a faithful computer simulation of the plant functions. The raw data available from training simulators are normally computer logs and various automatically generated recordings of the operator's performance, as well as the instructor's evaluation thereof. This may be supplemented by checklists (for the instructor), debriefing interviews and discussions based on replays of critical situations, and possibly the operator's self-evaluation. Since training simulators are aimed at simulating work situations, they provide data about normal situations as well as abnormal situations. The operator must be trained to run the plant during normal production, but also to be able to handle various faults.
- (4) Research simulators. Research simulators are designed for the study of operator performance during simulated real-life scenarios. A research simulator may be a modified training simulator or may be a specially constructed simulator. A research simulator normally simulates a typical plant rather than a particular plant, and the control room need not be a replica of any particular control room. Research simulators are quite often used to study experimental control rooms. The raw data available from a research simulator includes the raw data available in a training simulator, but the recording of the data is normally more flexible, to honour the requirements of various special purpose investigations. In addition to this, research simulators may provide data about operator verbalizations and comments including operator-experimenter dialogues, tape recorded during the experiment, as well as

data from self-confrontations, i.e. the operator's retrospective comments made during a replay of the experiment. Research simulators obviously provide data about normal as well as abnormal situations, although they normally use experimental sessions which are shorter than training sessions in the training simulators. A considerable advantage of research simulators is that they may be used to study particularly important incidents, which either have happened or may happen.

In addition to this, the raw data in both research simulators and training simulators may include various other types of performance recording such as physiological measurements (EKG, GSR, EMG, etc.), video-tape recordings, eye movement recordings, etc. This cannot be done for plant events and plant interviews. The reason for this is simply that in the latter case one does not know in advance neither when to record something nor what to record. The convenient feature of simulators is that the instructor or experimenter knows beforehand the nature of the disturbance the operators have to control and will be able to prepare for observations and interviews.

Data Analysis

Just as the types of raw data may vary from one source to another, so may the purpose of the analysis of the raw data depend on the context. In plant events the purpose is to identify the characteristics of the situation and of the event, which adequately account for what occurred, to identify possible needs for improvement of work planning or instructions. In plant interviews the purpose is to identify the critical decision sequence which led to the observed performance; this is not radically different from the purpose of plant event analysis, although the emphasis may be put on an understanding of human performance rather than the correction of specific work conditions. In training simulators the purpose is of course to improve the training by improving the feedback the instructor can give to the operator. And in research simulators

the purpose is either to gather data about a particular problem or to evaluate a specific hypothesis or assumption. This means that the way in which the raw data are analysed depends upon their type as well as the purpose. Fortunately this does not lead to, in this case, four completely different types of analysis, but rather several modes of analysis which have a considerable overlap and which are based on the same conceptual background. An important benefit to be gained from a common analytical frame of reference will be the possibility of cross-checking results and the availability of data from all sources for the research on operator performance models. One may, in fact, suggest a common description of the analysis along the lines described below, where each analysis typically has a number of discrete steps with intermediate results which can be characterized as follows:

- Raw data. This is the basis from which the analysis is made. Some examples of various types of raw data have been mentioned above and are summarized in fig. 1. The raw data may be regarded as performance fragments, in the sense that they do not provide a coherent description of the performance, but rather the necessary building blocks or fragments for such a description.

- Intermediate data format. This represents the first stage of processing of the raw data. In this stage the data are combined and ordered along a time line, to provide a coherent description of what actually occurred. It is thus a description of the actual performance but given in the original terms, i.e. as a professional rather than an expert description. The language used is the language from the raw data, rather than a refined, theoretically oriented language.

The step from the raw data to the intermediate data formats is relatively simple, since it basically involves a re-arrangement rather than an interpretation of the raw data. Hence special translation aids are not required.

SITUATIONAL CONTEXT TYPES OF DATA	PLANT EVENTS	PLANT INTERVIEWS	TRAINING SIMULATORS	RESEARCH SIMULATORS
CHECKLIST	■	■		
FREE TEXT COMMENT	■	■		
INTERVIEW		■		
EXPERT ASSESSMENT		■		
SPECIAL CHECKLIST		■	■	
COMPUTER LOG		■	■	■
TIME LINE		■	■	■
PERFORMANCE MEASUREMENT			■	■
INSTRUCTOR EVALUATION			■	■
DEBRIEFING INTERVIEW			■	■
"THINK ALOUD" & DIALOGUE				■
SELF-CONFRONTATION				■

Fig. 1. Typical relation between data types and data sources (situational context).

- Analysed event data. In this stage the intermediate data format, resp. the raw data, has been transformed into a description of the task or performance using formal terms and concepts. These concepts reflect the theoretical background of the analysis, typically a combination of an information processing theory and a theory for decision making. The description of the performance is still ordered along a time line which is specific to the situation in question. The transformation has, however, changed the description of the actual performance to a formal description of the performance during the specific event.

The step from the intermediate data format to the analysed event data may be quite elaborate, since it implies a theoretical analysis of the actual performance. The translation is one from operator task terms to formal terms. The emphasis is also changed from providing a description to providing an explanation as well. Special translation aids (tools, methods, and concepts) are therefore required.

- Conceptual descriptions. At this stage of the analysis, the description is no longer specific to a particular event but rather aimed at presenting the common features from a number of events. By combining formal descriptions of performances one may end up with a description of the generic or prototypical performance. The prototypical performance may still be described as a sequence of activities ordered along some time line, but this is rather a time axis than a time line referring to an actual situation. On the other hand, a description of the performance in a specific event may be seen as an example or a variation of the prototypical performance. Thus generic descriptions of human error mechanisms are, in fact, descriptions of typical deviations from the prototypical performance. The validity of the prototypical performance may therefore be tested either by determining whether a given formal description of an actual performance, i.e. a given case, can be subsumed under the prototypical performance, or by comparing it with predictions of typical performances made from the prototypical performance.

The step from the formal to the prototypical performance is again one which is quite elaborate. It therefore requires not only a number of special translation aids but also a considerable experience with the analyst. He has to provide a description, based on generalizations from specific events, which permits the prediction of the typical performance in specific tasks.

- Competence descriptions. This is the final stage of the analysis which combines the conceptual description with the theoretical background. The description of competence is concerned with the basic concepts, such as ~~mental models~~, decision strategies, performance criteria, preferences, problem solving strategies, etc. which in a given situation are combined to produce the performance. The description of competence is context-free; it is a description of the behavioural repertoire of the operator independent of any particular situation - though, of course, still restricted to a certain class of situations. As soon as a context is provided, the description of the competence can become a description of the prototypical performance and, pending further information, a description of the typical performance. The competence description is thus essentially the basis for performance prediction during system design.

As before, the step from the conceptual description to the competence description may be quite elaborate and require that the analyst has a considerable knowledge of the relevant theoretical areas as well as a considerable experience in using that knowledge. It is not so much a question of knowing particular tricks and tools, as of being able to consider the conceptual description in a broad theoretical context. He has to provide a description in task-independent terms of the generic strategies, models and performance criteria which lie behind the performance.

(A summary of the steps in this common analysis is shown in fig. 2).

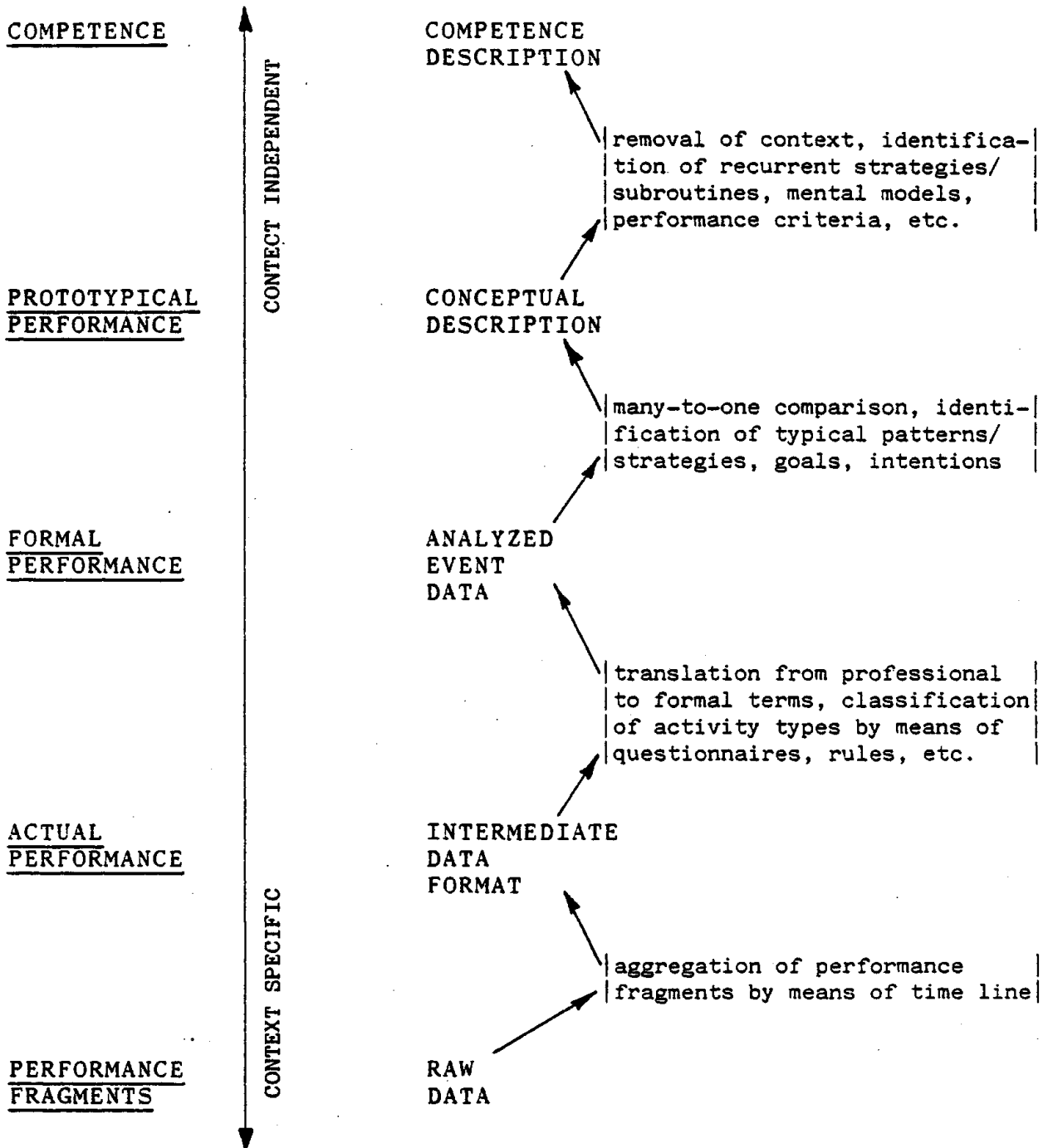

Fig. 2. Illustration of the steps in the common analysis of data.

In the following discussion, the features of methods and tools needed for the transformations between these data levels are considered and some practical formats and guides are proposed, related to the different data sources. The discussion will be related to the matrix illustrating the tools for different data sources, see fig. 3.

THE APPLICATION OF RESULTS FROM VARIOUS LEVELS OF ANALYSIS

The various types of situations (data sources) will normally be analysed until a level of analysis is reached, which is appropriate for the situation. This means that the results at the various levels of analysis may have different applications, both with regard to situations of different types and with regard to situations of the same type. To demonstrate this, we shall take a look at how the results from training simulators may be used in various ways. After that we shall briefly see how a similar description may be given for the other cases.

The application of the results from the various levels is, of course, dependent upon the context. In the case of training simulators the purpose is primarily to train operators to control nuclear plants. But apart from this one may also gather valuable data which can be used for a more theoretical line of study. Such a project is presently under development and is described in outline in Hollnagel and Rasmussen, 1981. In the present discussion we shall assume that the training simulator is used for this double purpose.

On the lowest levels, the intermediate data format and the analysed event data, the description is still directly related to the specific situation. Therefore the application will primarily be in the training, i.e. as a part of the feedback the instructor gives to the operator. The analysis produces an integrated description of the performance by means of the time line, and does also, in the formal performance, refer this

USE	ERROR QUANTIFICATION DESIGN IMPROVEMENT	NEW DESIGNS, PREDICTION & EVALUATION		TRAINING DESIGN & INF.
CONCEPTUAL DESCRIPTION - PROTOTYPICAL PERFORMANCE				
FORMAL DESCRIPTION - ACTUAL PERFORMANCE	<p>CODED CASES</p>	<p>FORMALISED TIME SEQUENCES</p>	<p>PERFORMANCE STRUCTURES & PATTERNS</p>	
TOOLS & CONCEPTS	<p>TAXONOMY</p>	<p>MODELS</p>	<p>ANALYSIS FORMATS & CLASSIFICATION GUIDES</p>	
INTERMEDIATE DESCRIPTION - ACTUAL PERFORMANCE		<p>TIMELINE FORMATS</p>	<p>TIMELINE RECORDS</p>	<p>TYPICAL DECISION PATTERNS</p>
RAW DATA	<p>ANECDOTAL TEXT</p>		<p>COMPUTER LISTS</p>	<p>PROTOCOLS</p> <p>REORDER CHARTS</p>
	EVENT REPORTS	PLANT INTERVIEWS	RESEARCH SIMULATORS	TRAINING SIMULATORS

Fig. 3. Illustrative overview of the various formats of performance descriptions and their application for different stages of analysis.

description to the conceptual background. The formal description is a more precise theoretical description of the operator's performance, and the use of a well-defined terminology may highlight features of the performance which would be inconspicuous in a common-sense description. The results of the analysis at these levels may therefore be used to aid the operator in his learning, by giving him a description of his performance, or the most essential parts of it, which accurately characterizes its weak (and strong) points. The two first steps in the analysis are those where the expert's opinion and evaluation may be made directly accessible for the operator - both in terms of time and ease of comprehension.

On the next level - the conceptual description of the prototypical performance - the results may be applied in various ways. The conceptual description is characteristic by being based on a many-to-one comparison, i.e. it is concerned with the general features of the performance rather than the particular characteristics. It is thus no longer tied to a specific performance, and therefore not useful as a feedback to a specific operator. It may, however, be used as a feedback to the training program as such, i.e. as a basis for evaluating the efficiency of a whole training program. Based on the conceptual description it may be assessed whether or not the goals for the training have been accomplished, and where the differences may be. This makes it possible to evaluate a program without evaluating individuals - which for obvious reasons is an attractive quality.

It is also at this level that the results may be used for theoretical studies. It could be the study of e.g. typical strategies in problem solving and diagnosis, the influence of specific conditions such as displays, procedural support, team interaction, or the way the operator copes with multiple tasks and goals. The level of the conceptual description is therefore the level which is intended in all investigations which are not restricted to person-specific purposes. This, by the way, is so whether the investigation is of a qualitative or a quantitative nature. The analysis of most investigations will therefore be

carried through to this level, whether it is explicitly stated or not.

A final application of the results at this level is the further development of the conceptual background. This occurs in combination with the results from the highest level of analysis, the competence description. We have already referred to this in the section on the role of the concepts in the analysis. This further development of the concepts and theories is, of course, only seldom a direct purpose of the analysis. But it is an inherent part of a qualitative investigation. Figure 4 contains a representation of the relation between the levels of analysis and the applicability of the results as described above.

For the other types of data sources a similar description may be provided. It is easiest first to look at the research simulator. This differs from the training simulator in not having the purpose of training someone, and in putting more emphasis on the theoretical study. Hence the results at the lowest levels, actual and formal performance, are used only in the debriefing which may be a part of the analysis, as e.g. in the method used in the Scandinavian NKA/KRU project. The main source of information is the conceptual description, since it is here that the hypothesis under investigation may be verified. In many cases a research simulator will also be used to develop a method, as in the KRU-Project, hence the results at the level of the competence description will also be used.

In the case of plant interviews, the analysis at higher levels of description serves to identify problems and methodological requirements for other lines of research, rather than to generate performance models, since the number of descriptions of incidents will be small. For plant events, the most important applications will be the feedback in terms of corrective measures for plant operation as well as the use of quantitative data at the level of prototypical performance for prediction of error rates in reliability and safety analysis.

COMPETENCE		REQUIREMENTS FOR TRAINING CONTENT OPERATOR SELECTION AND STAFF ORGANISATION		EVALUATION OF TRAINING CONTENT
PROTOTYPICAL PERFORMANCE	RELIABILITY AND RISK PREDICTION	ACCIDENT MODELLING		EVALUATION OF TRAINING PROGRAMMES
CONCEPTUAL DESCRIPTION	REQUIREMENTS FOR INTERFACE, INSTRUCTION AND TRAINING SYSTEMS		EVALUATION OF DESIGNS FOR INTERFACE AND INSTRUCTIONS	
FORMAL PERFORMANCE	REQUIREMENTS FOR INDIVIDUAL SESSIONS FOR EXPERIMENTAL STUDIES AND TRAINING			
ANALYSED DATA				TRAINEE DEBRIEFING
ACTUAL PERFORMANCE	CORRECTIVE MEASURES FOR PLANT OPERATION	STUDIES OF SITUATIONS, SCENARIOS, MENTAL WORKLOAD		TRAINEE DEBRIEFING
INTERMEDIATE DATA				
PERFORMANCE FRAGMENTS				
RAW DATA				
FORM SOURCE	EVENT REPORTS	INCIDENT ANALYSIS	RESEARCH SIMULATOR	TRAINING SIMULATOR

Fig. 4. The table illustrates different applications of information obtained at the various levels of analysis of human performance data from various sources, together with the potential of transfer of results.

This discussion and the table in Figure 4 should only be taken to be illustrative. An important point is the interrelation between analysis of human performance data from different sources and the benefit to be gained by transfer of results. To support such transfer, a compatibility between the phases of analysis of the different sources must be carefully considered. We have identified this need in several of our programs, and it has also been part of the rationale for the discussion in the present report.

ANALYSIS OF ROUTINE EVENT REPORTS

Routine event reports, such as the U.S. Licencee Event Reports, are valuable data sources on human performance, if the reports are reviewed and edited by a professional expert who is familiar with the technical content of the task and with the actual work situation as, e.g., exemplified by the Nuclear Power Experience, Inc., compilation.

The information collected during event recording should have a content and a degree of detail making it possible during analysis to identify several characteristics of the situation and events related to inappropriate human performance. For in-plant data collection, a taxonomy (see figs. 5 and 6) for identification of such characteristics has been proposed to an OECD/CSNI working group (Rasmussen et al., 1981). It is proposed to collect all plant and task data directly according to this taxonomy, whereas the analysis of the human characteristics probably should be performed by a human factors specialist based on free text descriptions. For this data source the raw data are therefore found as checklists and free text comments.

For simple event reports, there is no need for an intermediate data format describing the formal performance, since it will not be possible to derive a time line description from the data. In general the state of the plant and the characteristics of the task and work situation can be collected directly in the

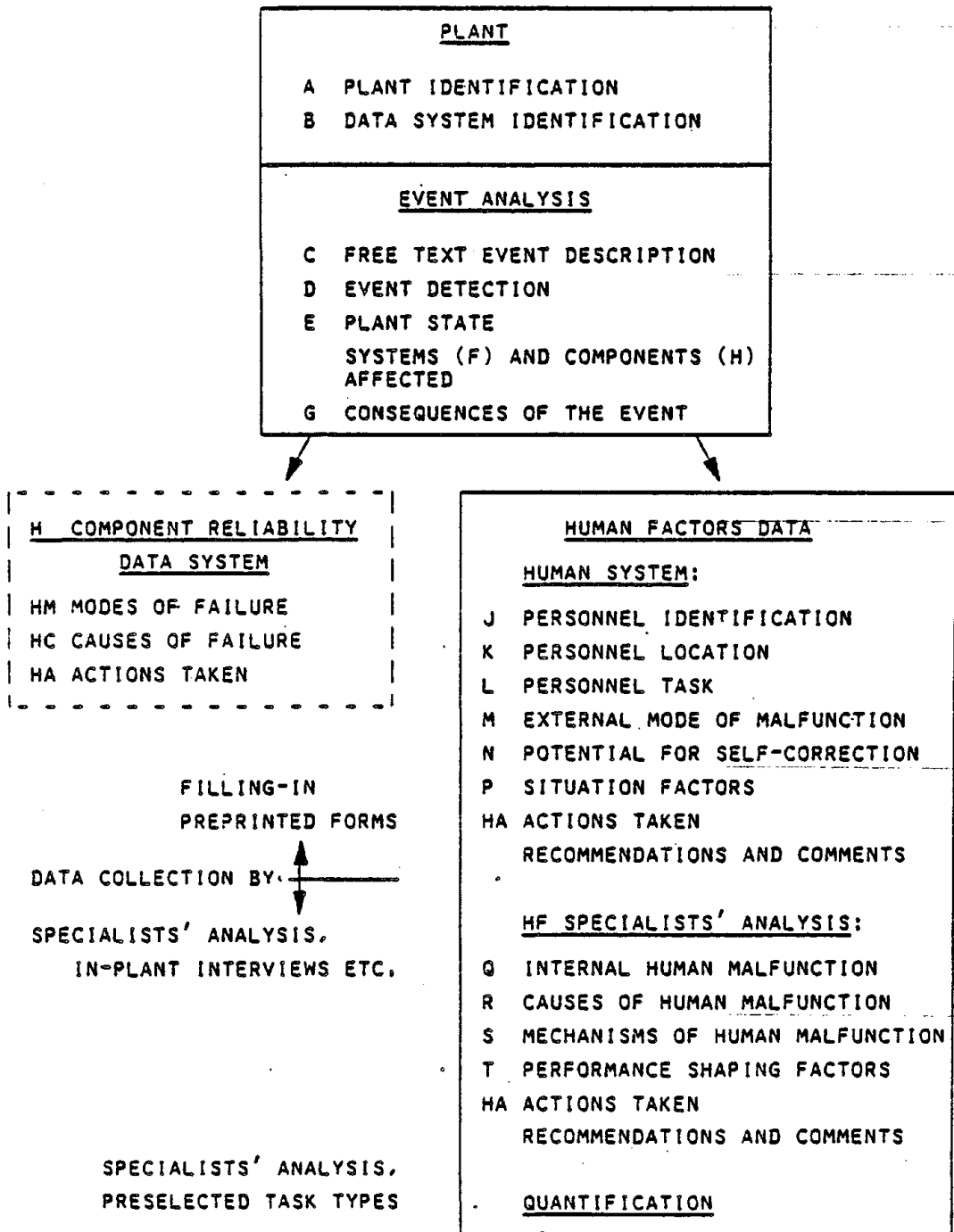

Fig. 5. Use of human malfunction taxonomy.

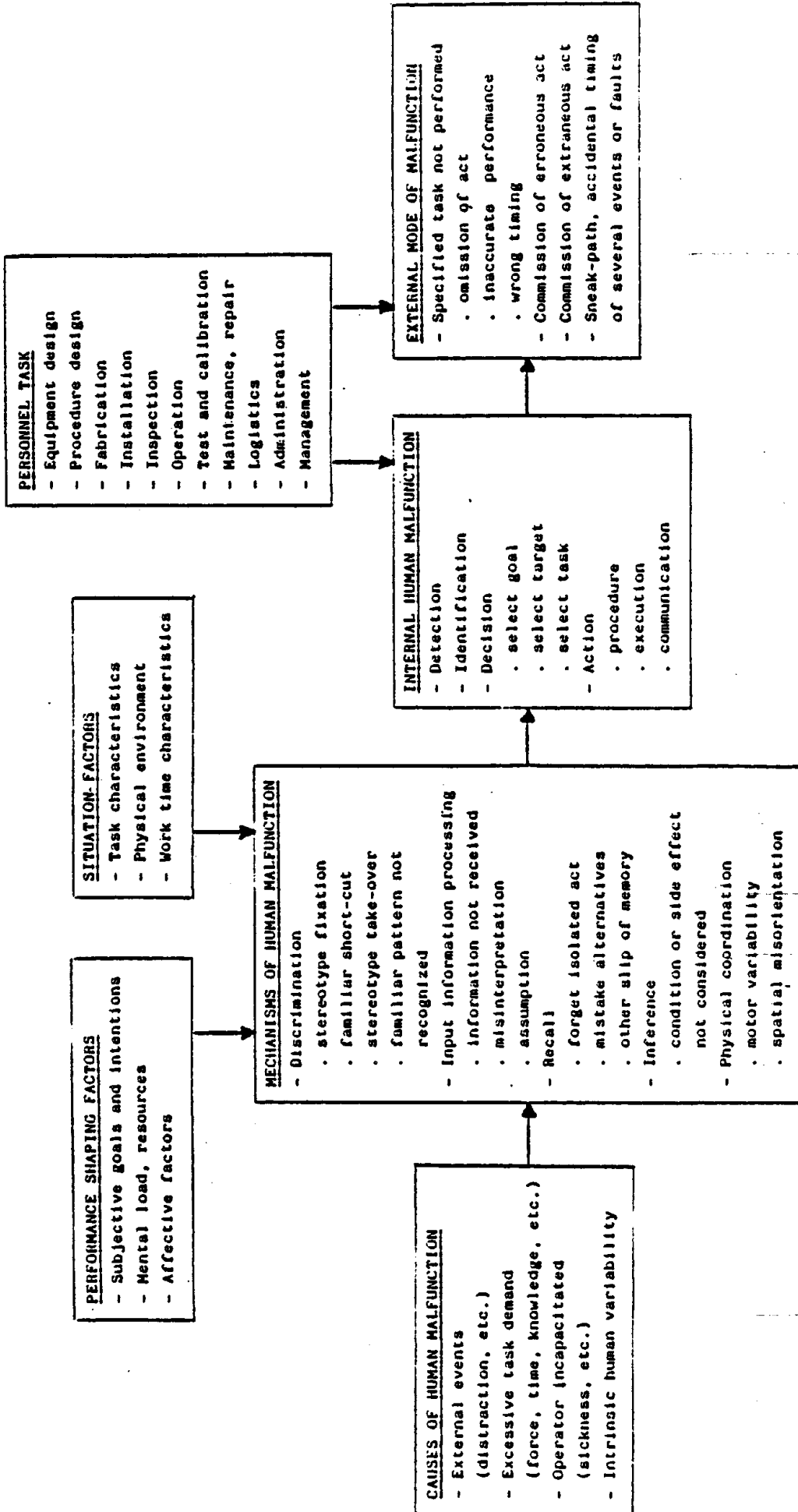

Fig. 6. Multifacet taxonomy for description and analysis of events involving human malfunction.

terms of a suitable taxonomy by means of a checklist (see fig. 5). The causal structure of the human malfunction must, however, be identified by an analyst with human factors background from a free-text description giving information which adequately covers the aspects of the work situation which are defined by the categories of fig. 6.

When a considerable number of events has been analysed and coded according to the taxonomy, it will be possible by statistical correlation analysis to suggest generic or prototypical human malfunction mechanisms and to relate these to features of the work situation. This result then makes it possible to identify and predict likely human malfunctions in a new task design, when the related prototypical task performance has been determined experimentally or by analysis.

Analysis of the event descriptions to classify according to the categories of fig. 6 depends upon a consistent model of the internal human data processing which is needed for the task; the related mechanisms of malfunction; and their causal relations to the work situation. In the following sections, the different categories of the taxonomy of fig. 6 are related to a model of human performance and guidelines for the event analysis are proposed.

Internal Human Malfunction

This category describes the internal mental function of the operator's decision making which was inappropriately performed. It is based upon the model of the human decision process which is illustrated in fig. 7.

From the event analysed, information must be available which makes it possible for the analyst to identify the decision process that has been performed erroneously or has been inappropriately bypassed by a habitual leap, as indicated in the figure.

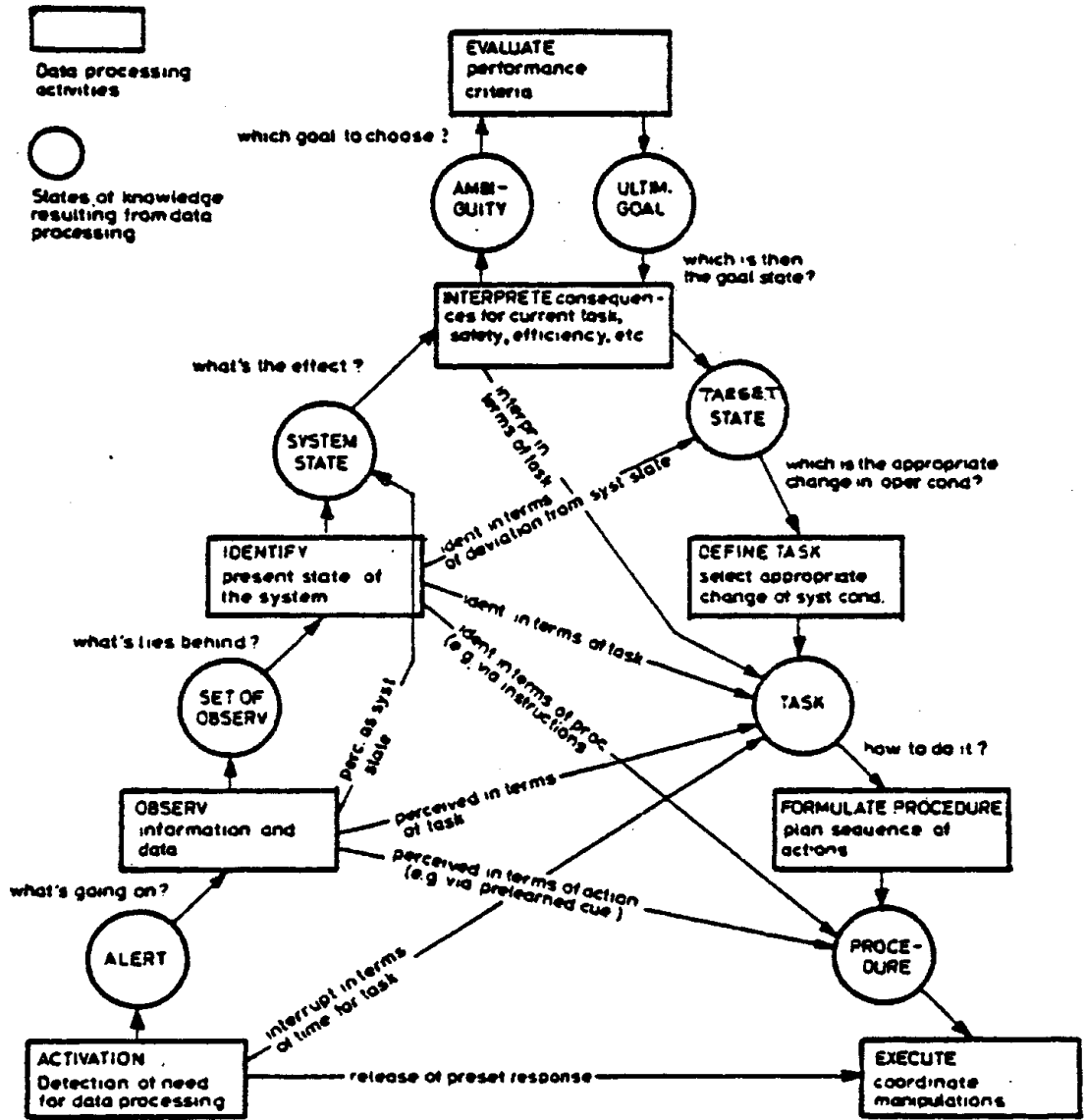

Fig. 7. Model of human decision sequence.

The use of these decision categories is ambiguous in several ways and some conventions are necessary to give consistent classifications.

First of all, human performance has basically a hierarchical structure and it may consequently be a matter of choice as to which level the decision categories are used and how they are brought into use. This choice will depend on the circumstances during which inappropriate human performance is found and on the amount and quality of the information available from the event.

One typical example will be a skilled operator making a single erroneous decision during normal or near-normal work situations. In this case the decision categories will be used on a high level of task planning, partly because highly professional people are only making "decisions" at a high level to control their skilled and more subconscious routines, and partly because routine event reports do not include information for identification of decision errors at a lower level, even though they may appear; e.g., if a skilled routine must be modified. A repair task can be taken as an example: If the equipment fault is incorrectly diagnosed, the inappropriate mental function is classified as "identification". However, if the fault is correctly identified and the task of replacement properly mentioned but inappropriately planned because the internal state of the equipment is not properly identified at a lower level, then the mental malfunction will be classified as inappropriate procedure.

For cases including several inappropriate human decisions which are related in the chain of event, we normally only classify the first malfunction when the source of information is routine reports. This is due to the consideration that the situation following an erroneous decision is too complex to allow the analyst to judge the basis of the subsequent decision from routine reports, and the normal classification categories may not apply. The variability, e.g., for human decision making, in a situation created by acts based on misidentification of the

state of the system, is only accessible through very detailed in situ analysis based on interviews, as discussed below and done by Pew et al. (1981) or analysis based on data collected from training simulators for which a reasonable number of similar, complex situations can be planned.

A systematic guide to the analysis of simple routine event reports, to identify "what was wrong", is proposed in fig. 8.

In the present context of analysis of human malfunction, the step "observation" of fig. 6 is not included in the category "internal malfunction" since inappropriate observation or selection of information may be implied in malfunction during each of the following decision steps. Instead, different "mechanisms of malfunction" related to observation is included below.

Mechanisms of Human Malfunction

This category describes the psychological mechanism involved in the mental function which was inappropriately performed. The internal human malfunction describes what went wrong; the internal mechanism indicates how it went wrong whereas the question why is taken into account in the category of causes of human malfunction.

The categories of mechanisms of human malfunction are closely related to the categories of human behaviour which are represented in the model of fig. 9.

The categories of "internal human malfunction" and those of "mechanisms of human malfunctions", which are related to categories of internal human information processes and of internal human mechanisms, respectively, are basically different concepts and should therefore be considered separately during event analysis. Generally, there is a rather close correlation between information process types and of mechanisms used for the activity during skilled professional performance. Since, however, event analysis will include situations of all

INTERNAL HUMAN MALFUNCTION
WHAT FAILED?

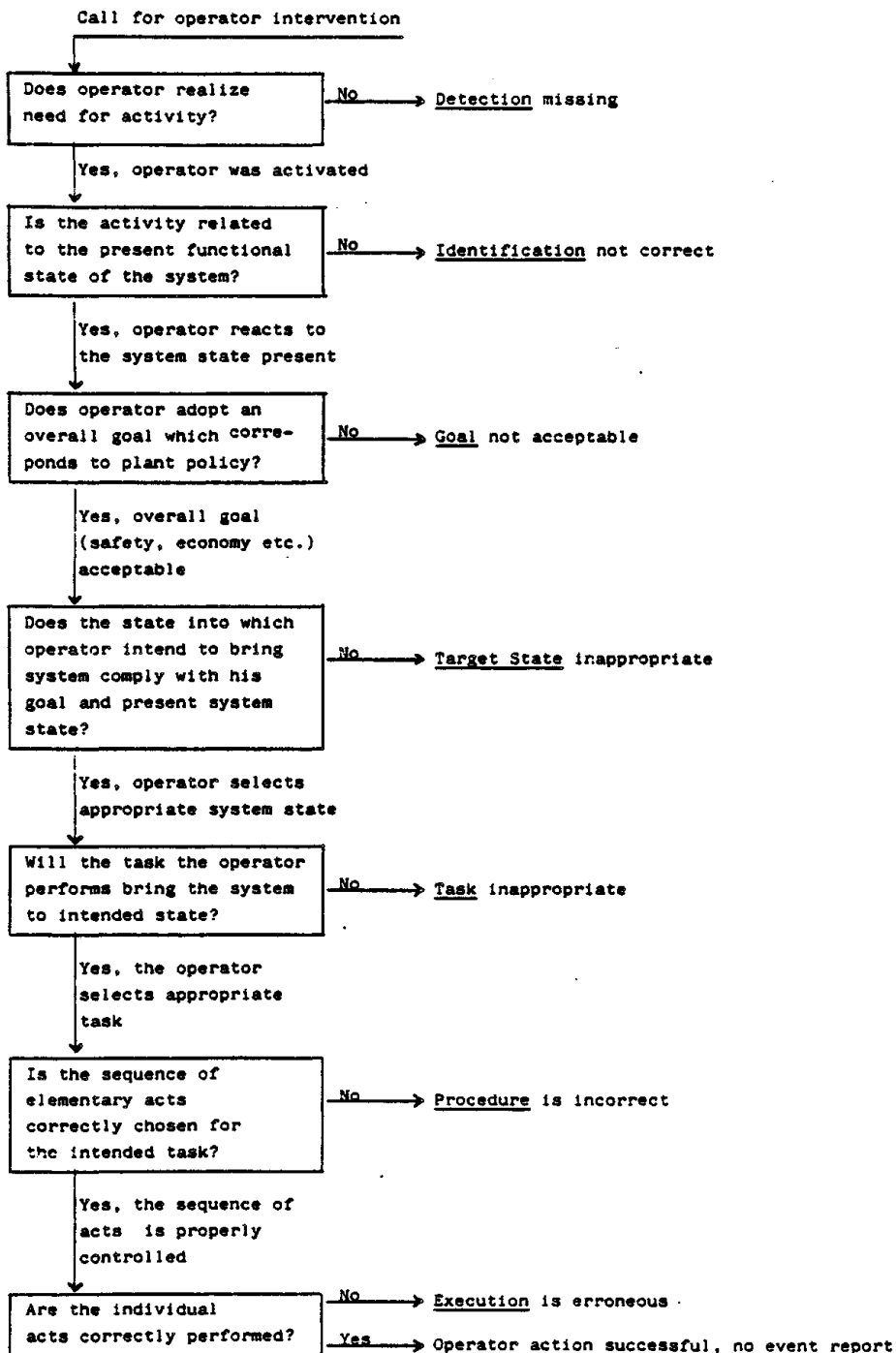

Fig. 8. Guide to identify the internal human malfunction from event analysis.

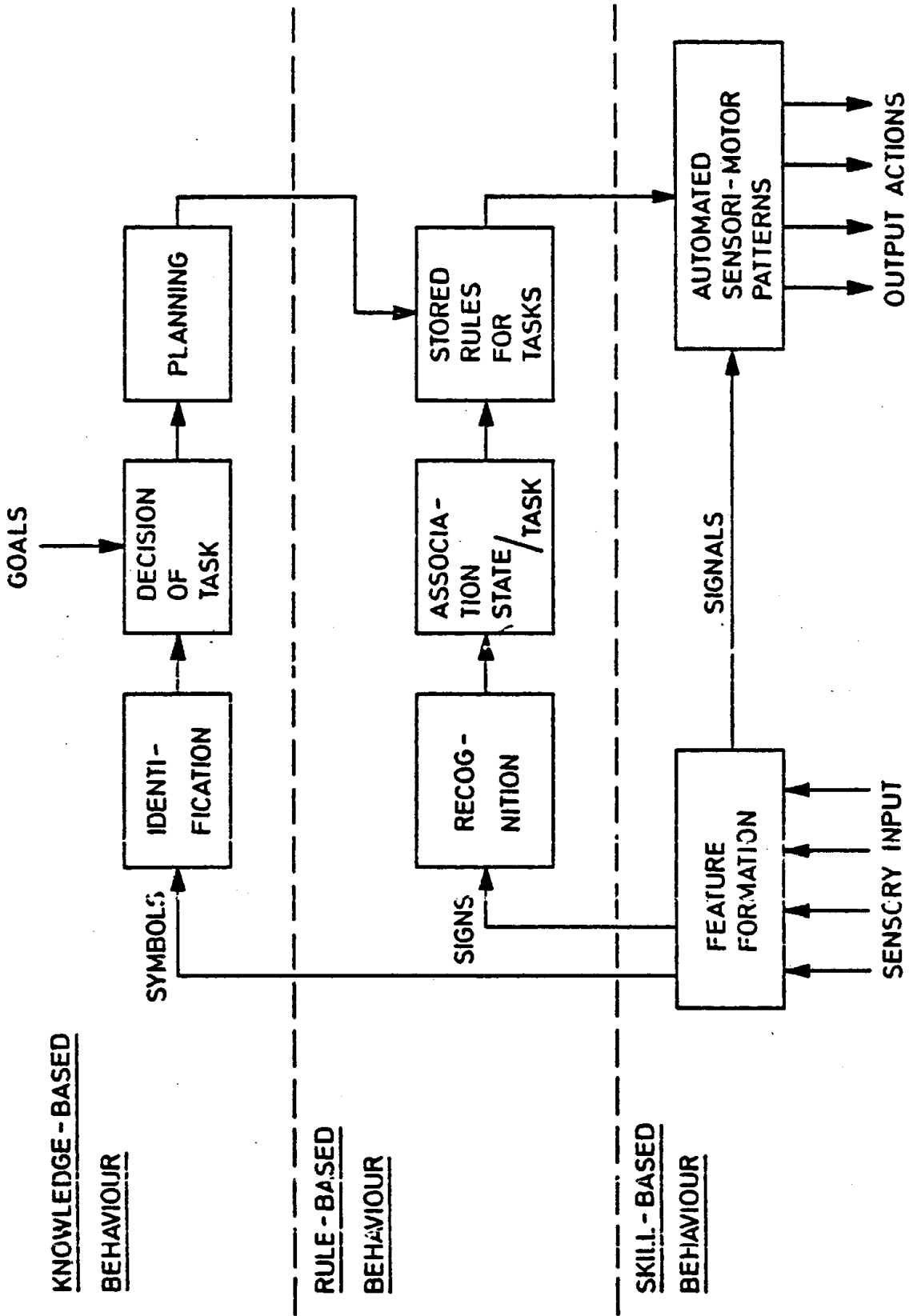

Fig. 9. Schematic model of three different levels of human information processing.

degrees of familiarity for operators, we maintain that the categories of information processes and psychological mechanisms should be kept separate during analysis.

An important mechanism is related to the activation of the proper domain of cognitive behaviour and thus to the operator's discrimination of the nature of the situation he is facing, i.e., whether he is allowed to use his highly trained habitual routines, his repertoire of rules and know-how, or he has to exercise his functional understanding in causal deduction and planning. From fig. 9 it is seen that the correlation between activity and mechanisms is mostly pronounced in the planning-rule-action end. It should, however, be realised that the content of the boxes of the model depends very much on the person's familiarity with the situation: the same activity may demand careful planning by one person but be part of a habitual routine for another person. The input activity of identification takes different forms as feature formation/recognition/identification at the three levels of behaviour and will consequently imply different mechanisms of malfunction. Again, the correlation of activity and behaviour depends very much on person and situation related features.

The categories proposed should not be taken as a final set; the intention of event analysis will be to collect information on the frequency and circumstances (causes) for the well-known, typical human errors and to get information leading to understanding of the more infrequent and complex error mechanisms. Therefore, the taxonomy includes categories which from a preliminary analysis of 200 U.S. Licencee Event Reports have been found typical (Rasmussen, 1980). Since they have been found to cover the larger part of the cases, an immediate classification during event recording will save the effort for detailed data collection in the more complex situations. A guide to classification of the most frequent types is given in fig. 10.

An important category for which detailed data collection and analysis are needed is the operator responses to abnormal

MECHANISM OF HUMAN MALFUNCTION
HOW IT FAILED

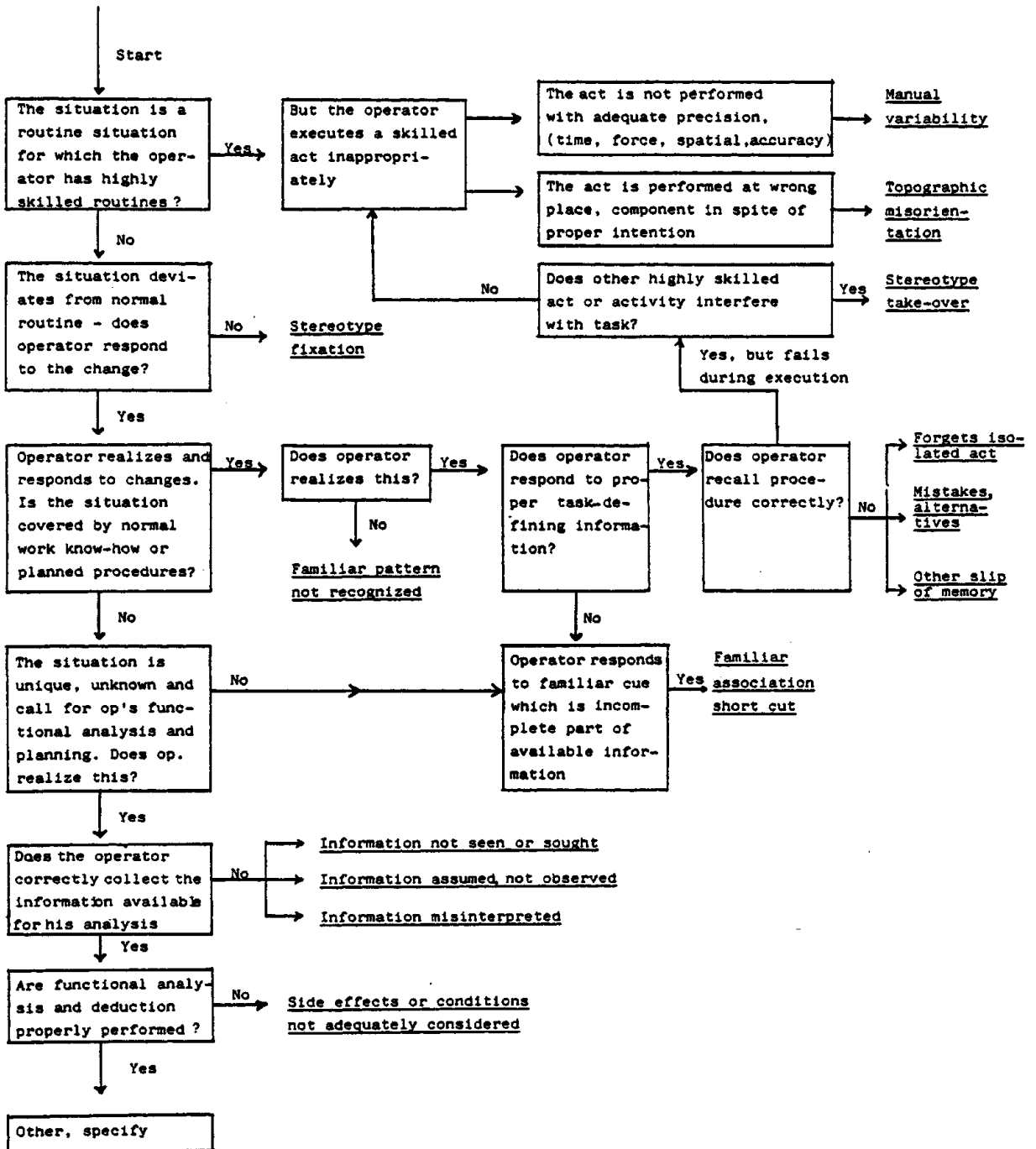

Fig. 10. Guide for event analysis to identify the internal mechanisms of human malfunction.

situations when he has realized that knowledge-based reasoning is needed. In this knowledge-based domain there is very little correlation between the activity types of identification, decision and planning - which are described in more detail on the ladder of abstraction of fig. 7, and the underlying types of psychological mechanisms related to functional, causal deduction and search which will be applied in all the activities. In the present taxonomy, all mechanisms related to this level of behaviour are lumped in the category of malfunction during inference: inadequate consideration of conditions or side effects. Future studies, e.g. in training simulator sessions, will hopefully serve to make this category more detailed, as well as more infrequent categories now lumped in the category "other". It is therefore important to have good, free text description of cases relating to these two categories.

Causes of Human Malfunction and Performance Shaping Factors

This category should identify the possible external causes of the inappropriate human action. A malfunction or error implies a normal, planned, expected act or some other kind of reference function against which the event is judged to involve a human malfunction. In short, a malfunction implies a change from normal, and this change can be due to spontaneous internal human variability or a change in the external task condition. To explain the human malfunction and, in particular, to collect reliable information on its frequency of occurrence, it is necessary to identify the causal chain of events.

More general factors of the environment such as physical environment, e.g., noise level, humidity, temperature are not considered causal factors, but performance shaping factors, since they do not themselves release a chain of events but modify the probability that other causal events will release a chain.

The category of causes within the present taxonomy should only be taken as illustrative. Specific sets should be identified in

the different specific applications since they will be very context dependent. A decision tree to guide data collection can therefore only be a framework ensuring consideration of the major classes, such as the one illustrated in fig. 11 related to causes, and figs. 12 and 13 related to some of the performance shaping and situation factors from figs. 5 and 6. The distinction between situation factors and performance shaping factors in fig. 5 is only caused by difference in collection method.

ANALYSIS OF COMPLEX INCIDENTS BASED ON IN-PLANT INTERVIEWS

The analyses discussed above of routine event reports are characteristic in that information is typically only given about the one critical decision - the "human error" - which was considered the "cause" of the chain of events. The information only gives a snapshot of a very complex man-machine interaction which is strongly dependent on the temporal context. If more reliable information is to be collected, either very careful interviews and task analyses must be performed after the fact, as described by Pew et al. (1981), or data collection and partial analyses must be done "on-line", as is possible e.g. on training simulators.

The analyses of Pew et al. are well suited in the present context to illustrate the transformation of raw data to intermediate and formal data formats, since they are based on a decision model very similar to fig. 7.

In the interviews and the intermediate data format (based on a time line description) which both serve as basis for discussion with the operating staff, the professional terminology of the operating staff is used. See fig. 14.

During analysis of the intermediate data in the form of time line description and special "work sheets" describing the

CAUSES OF HUMAN MALFUNCTION
WHY DID IT FAIL?

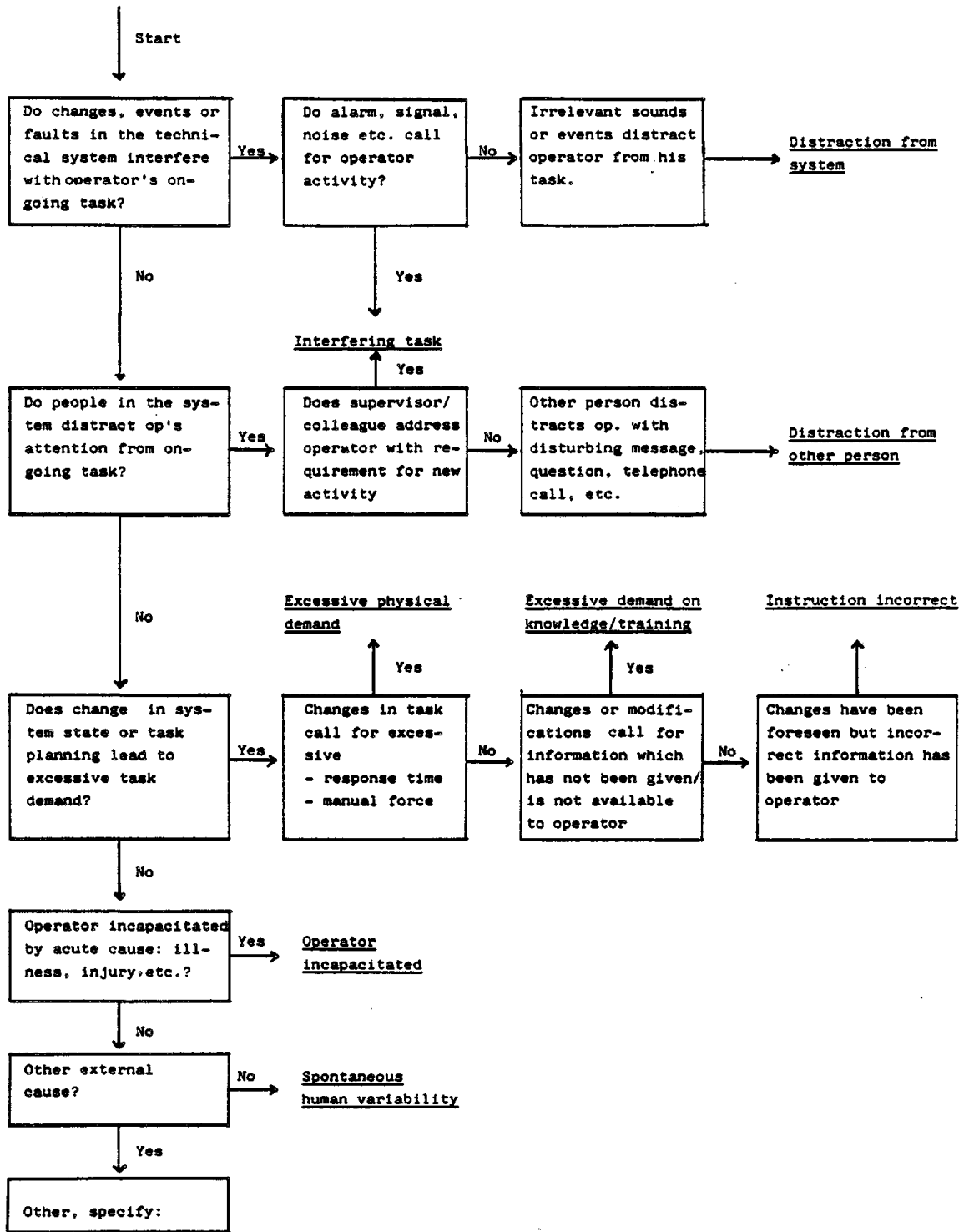

Fig. 11. Guide for event analysis to identify external causes of human malfunction.

PERFORMANCE SHAPING FACTORS

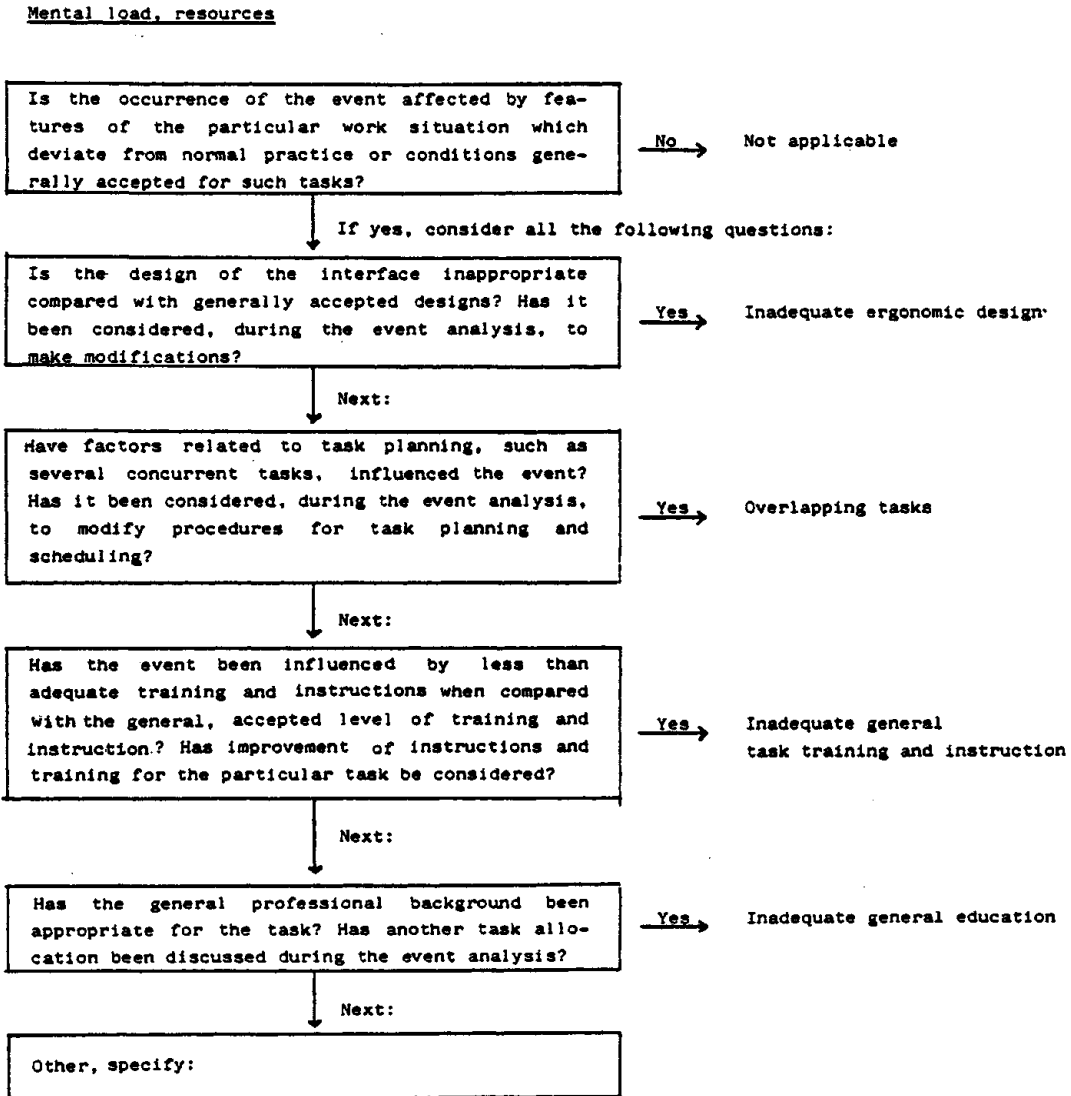

Fig. 12. Guide for event analysis to identify the influence of mismatch between mental load and resources.

SITUATION FACTORS:
TASK CHARACTERISTICS
"PREPAREDNESS"

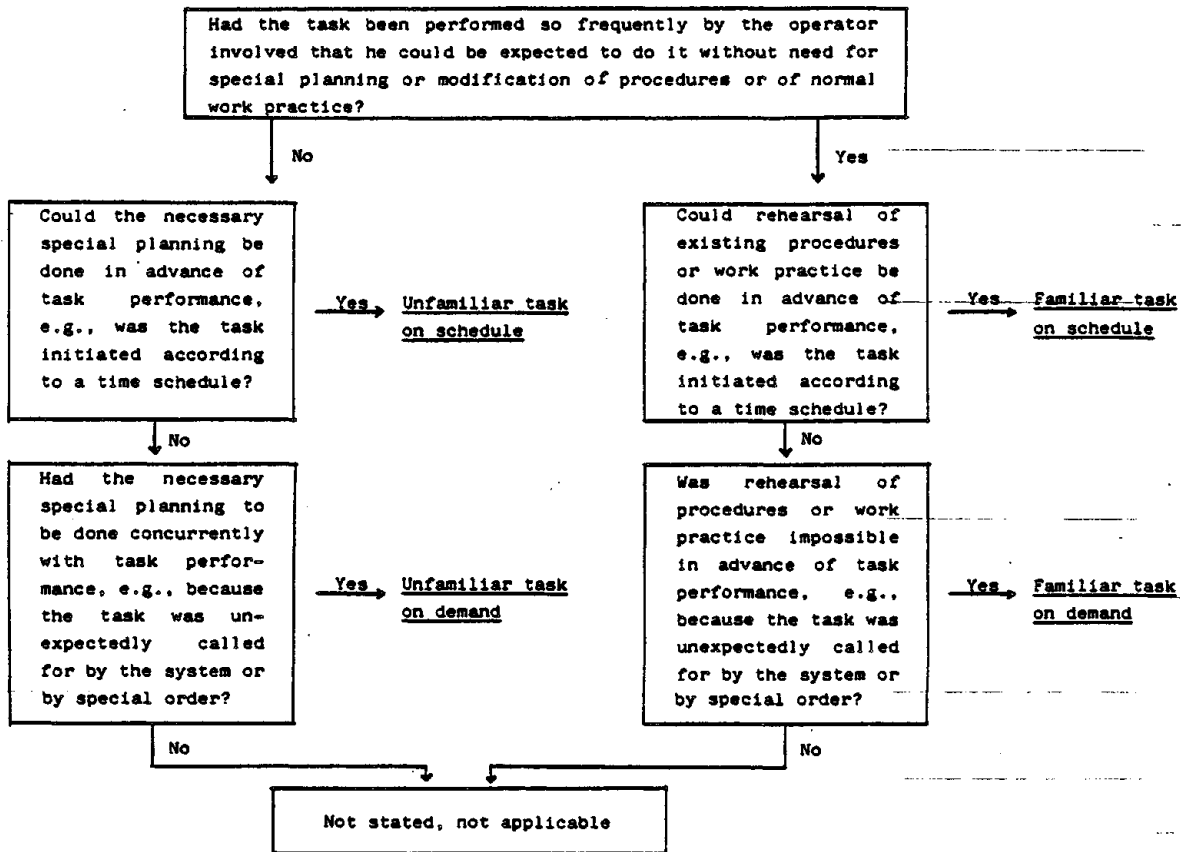

Fig. 13. Guide for event analysis to identify task characteristics determining the level of mental activity (see fig. 9).

OPERATOR DECISION/ACTION SUMMARY

Location: FI
Date: 10/2/79

Event: STA page 2 of 3

TIME	Avail. Info. or Stimulus (Info./Loc.)	Event Signaled	Knowledge and/or Belief State Components	Intention	Expectation	Decision/Action	Source for D/A	Immediate Feedback	Comments
1423	Continuing re-direction in pwr level, pressure; continuing release of radiation in condenser.	Augmented input to SC "A".	Diagnosis of SC rupture in "A" resulting in loss of primary coolant; load reduction will result in temporary increase in temperature in primary. /	Restore RCS volume to makeup for loss of water in primary loop of SC "A".	If small or intermediate sized leak, may be possible to offset loss. If not, auto. SI is inevitable unless manually initiated.	Start second charging pump (#11) / Consider manual SI / E6 and E1 procedures taken out of file.	SOP for primary LOCA.	#11 indicator light.	Appropriate response. Manual SI may be appropriate if leak is slower, and more time remains for planning response.
1424	Auto letdown isolation begun.	Pwr level setpoint reached.	May be small or intermediate sized leak.						
1424	Continued drop in pwr level and pressure.	Rate of loss not matched by operating charging pumps.	Continued loss probably indicates large rupture. / Charging pumps deliver low volume.	Make another attempt to "catch" loss.	Loss may be offset by using third charging pump (considered unlikely).	Start third charging pump (#13) / Continue consideration of manual SI.	SOP for primary LOCA.	#13 indicator light.	Appropriate response.
1424:09	Reactor trip alarm.	Pressure below 1900 psig setpoint.	Letdown isolation and three charging pumps have failed to offset loss.	Let E6S take over control.	SI will occur momentarily.	Await Auto SI / Continue monitoring of level and pressure.	Outcome of decision to let ESS function.	-	Manual SI could have been initiated between 1423 and 1424:14. Night have made it possible to control pwr level drop sooner. Operator action stress and feeling of "inevitable" entered into decision to defer to auto. SI. Also mention desire to demonstrate that automatic systems functions anticipated.
1	2	3	4	5	6	7	8	9	10

Fig. 14. Time line format to describe the actual operator decision and action performance. Reproduced from Pew et al. (1981).

"critical decisions", the information must be transformed into a structure using a set of concepts related to the formal decision model. One should not, however, expect to find information formulated by operators in terms which can be directly related to the concepts of this model, nor should these be used directly in interviews or questions. A more efficient way will be to ask for information in free text or common sense phrases which more broadly cover the issues to be analysed. The communication will be more free and the probability of obtaining the information which from the operators' point of view has been essential will be higher. An English language version of such categories used for data collection is shown in fig. 14 which has been reproduced from Pew et al. (1981), and there is a close relation between these categories and the concepts of fig. 7, as will be shown by the following comments (the quotations are from Pew et al.):

Column 2 : "Available Information"

Identifies the indications available on alarms, meters, recorders, etc.

Column 3: "Event Signaled":

Indicates the events and states actually present in the plant, and thus the source of the information in column 2.

Column 4: "Knowledge and/or Belief State Components"

"Present information on the operator's knowledge or belief about the state and events found in the plant". From this, the performance of the operators in the functions of observation and identification of system state (see fig. 7) can be judged. An advantage gained from the formulation of the information used by Pew et al. for this column is that not only the outcome of the activity but also information on the knowledge background and the expectations of the operator very likely will be represented in the free text descriptions.

Column 5: "Intention"

"This column is intended to give a brief characterization of the overall strategy or intention with respect to plant control that produced the overt decision or action identified later".

In terms of the categories of fig. 7, the information represents the interpretation and evaluation related to consequences of the plant state, the effect of possible operator interventions and the relation to the immediate operator goal. The information may very well be described in terms related to possible target states and tasks; in other words, the column may contain information on all the "downward leg" planning activities of the decision model of fig. 7.

Column 6: "Expectations"

"Expected outcomes of particular decisions or actions are summarized here"; the purpose is to "attempt to capture the essence of the operator's belief that if he carried out one or more specific control actions, the plant would respond in a particular way". This kind of information will make it possible to identify the processes by which the operator determines and decides about target state and task and will very likely contain information on the causes and mechanisms of erroneous decisions.

Column 7: "Decision/Action"

"This column contains a description of the specific decisions and actions taken by the operator". Being rather detailed descriptions of the actions taken or intentions for actions, this column contains the information needed for identification of the procedure which the operator follows, i.e., how the detailed task sequence is controlled.

Column 8: "Sources for Decisions/Actions"

"Bases for the specific decisions/actions appearing in column 7 are noted here. Most frequently, sources such as standard

operating procedures learned during training, cognitive model of plant dynamics, etc. will be specified in this column". This means that the operator's internal base for critical events should be represented here and it should be possible to derive information on error mechanisms and on external causes from the data in this column.

Column 9: "Immediate Feedback"

"This column contains identifications and panel locations of the status lights, meters, etc., that provide the most immediate feedback following the completing of control actions". This information is not directly related to the decision model of fig. 7, but is very important for evaluation of the feedback mechanism leading to human error recovery which is an important object of analysis in detailed event studies.

Column 10: "Comments"

This column should include information of task irrelevant embellishments such as interruptions, telephone calls, etc.

The preceding discussion indicates that a special analysis is needed to relate the information contained in the free text descriptions from interviews or tape records to the concepts of a formal decision model like that of fig. 7.

Comments

The result of this analysis will be a formal performance description in decision model terms like the time line format of fig. 15, with detailed comments on the decision points. From this description the prototypical performance can be derived, if an acceptable number of similar situations can be obtained. This will in general only be possible from training simulator studies and the related analysis will be discussed in a following section.

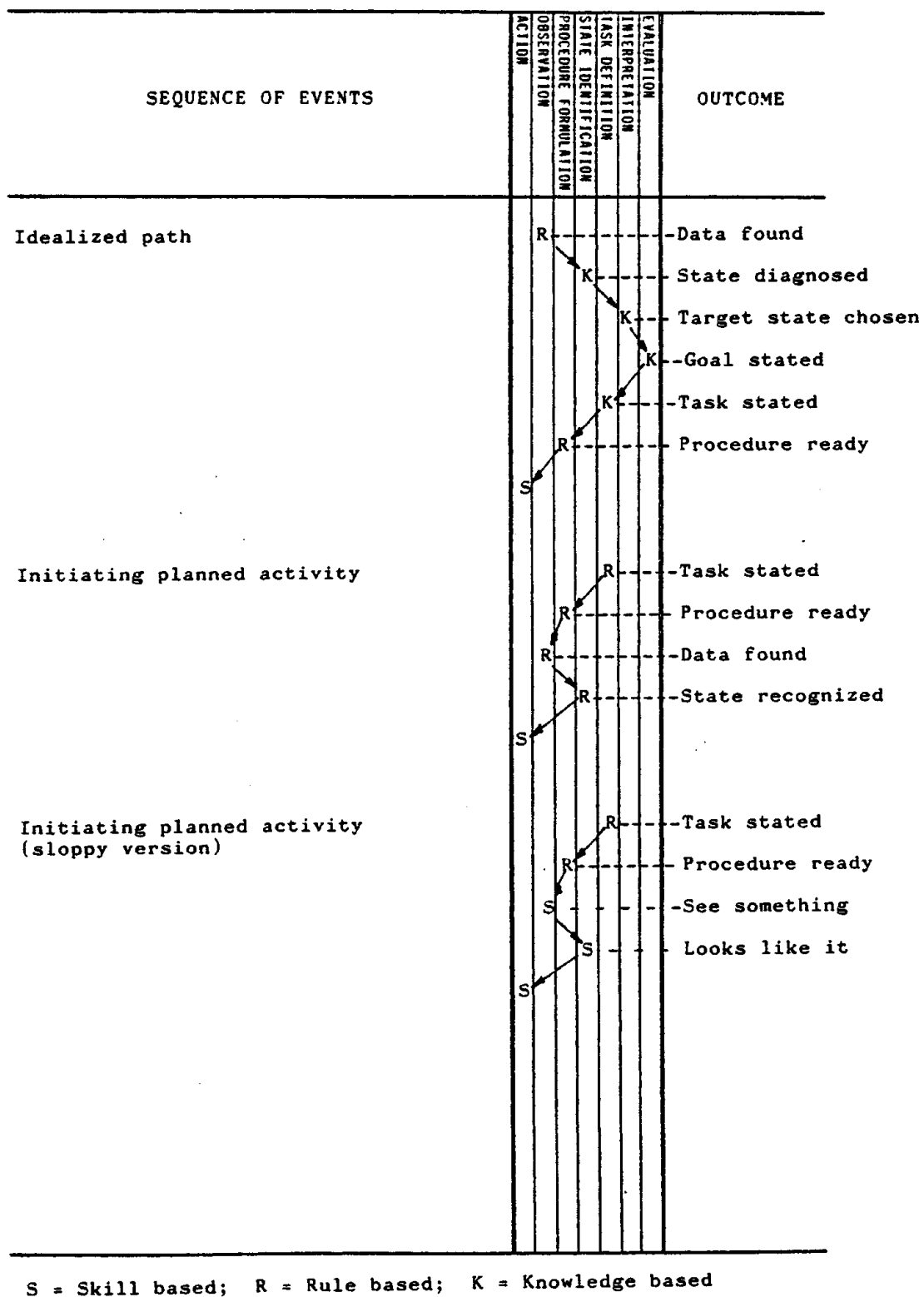
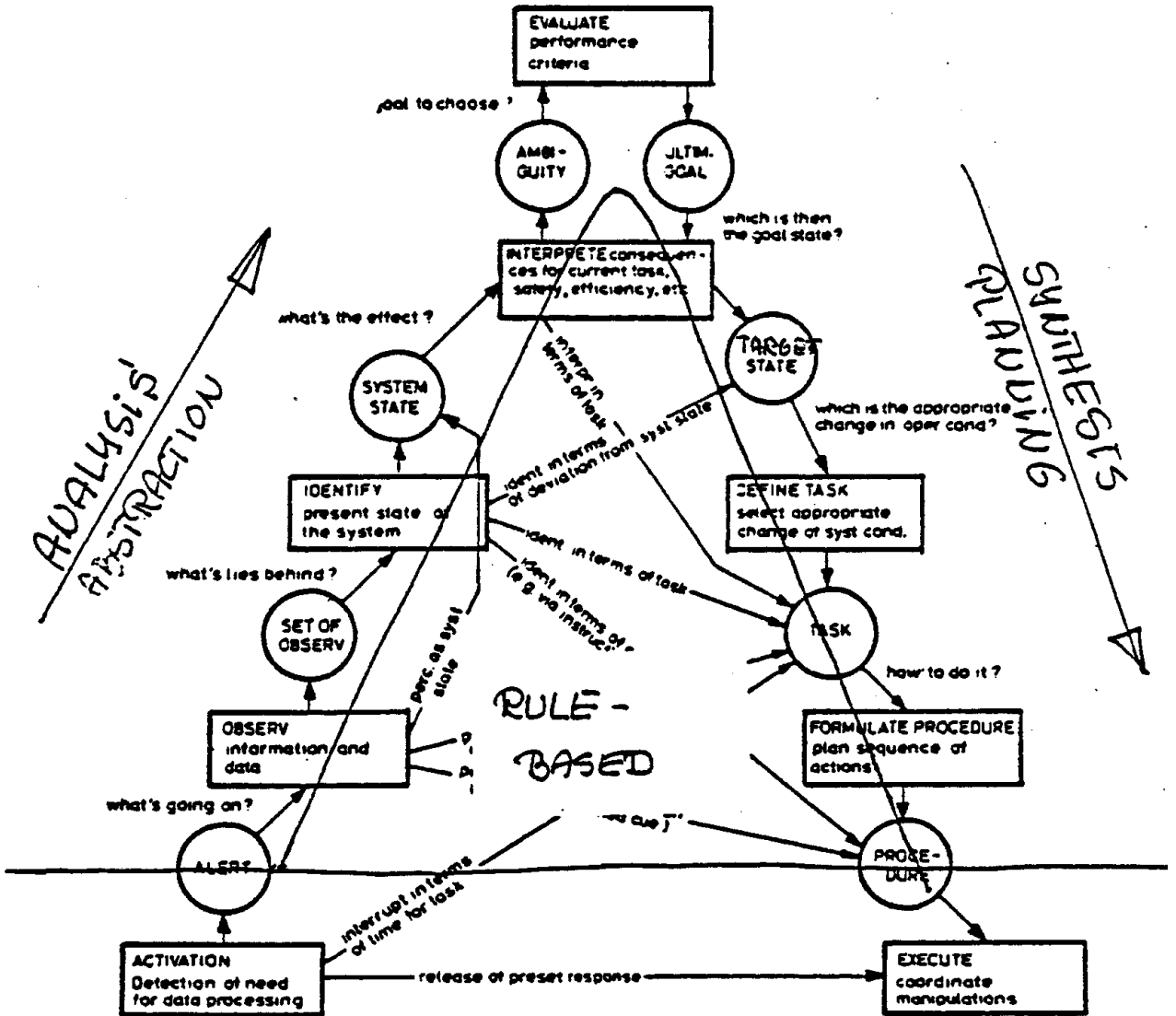

Fig. 15. Time-hire format to describe formal operator performance.

The time line format of fig. 15 is derived from the step-ladder model of fig. 7, by folding the legs of the ladder of abstraction. This provides us with the main categories or activity classes of the time line format. But in addition to that it seems to be practical to define the activity classes of the model more clearly, i.e. to specify them in greater detail. A basis for doing this may be found by comparing fig. 7 with fig. 9. Both figures illustrate the same basic conception of human performance, but each emphasizes different aspects. The step-ladder model (fig. 7) is mainly concerned with the basic rational decision sequence, while the three-layer SRK model of fig. 9 specifies the domain of control of human performance by means of the three categories of behaviour: Skill-based, Rule-based, and Knowledge-based (hence the name). The relation between the two models is illustrated in fig. 16. For analytical purposes it will, however, be an advantage if different names are used for the activity classes when they refer to either of the three categories of behaviour. Thus for example the activity class identification may be divided into the skill-based feature match, the rule-based classification or check, and the knowledge-based diagnosis. In this way the relation between the two models may be described as in fig. 17, which is an expansion and conversion of fig. 16. The more detailed set of activities described by fig. 17 is then used to describe the activities of the performance as shown by the time line in fig. 15.

For real plant situations, the very detailed analysis based on interviews can be used to identify human error mechanisms and, in particular, to identify decision mechanisms in complex, abnormal situations. The critical decisions can be described by use of the taxonomy of fig. 7, or when high correlation is found among the categories of the taxonomy, the relation can be presented in the form of "Murphy Diagrams" as used by Pew et al., see fig. 18.

KNOWLEDGE-BASED



SKILL-BASED

Fig. 16. Sketch to illustrate the relationship between the ladder-of-abstraction model of human decision making and the model of internal mental mechanisms of fig. 9.

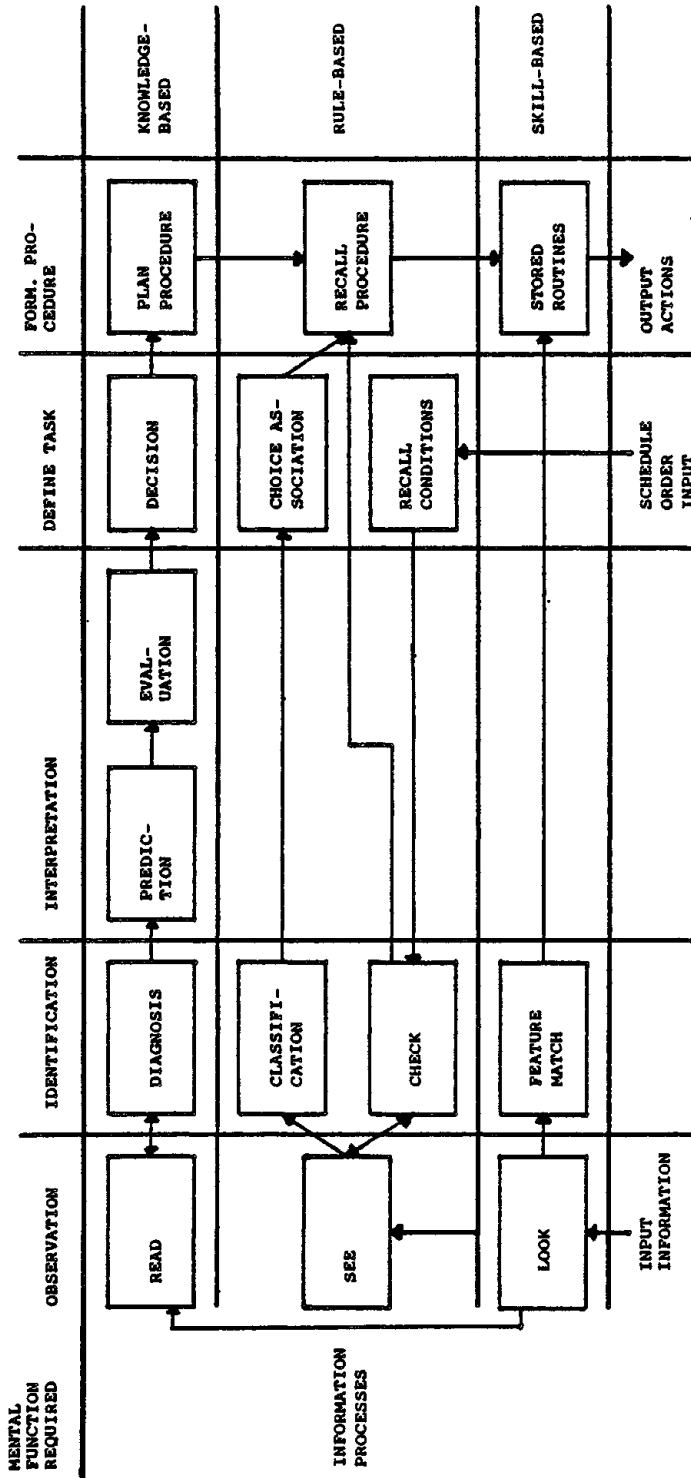

Fig. 17. Schematic diagram to various internal data processing mechanisms which can be applied to the steps of a decision sequence.

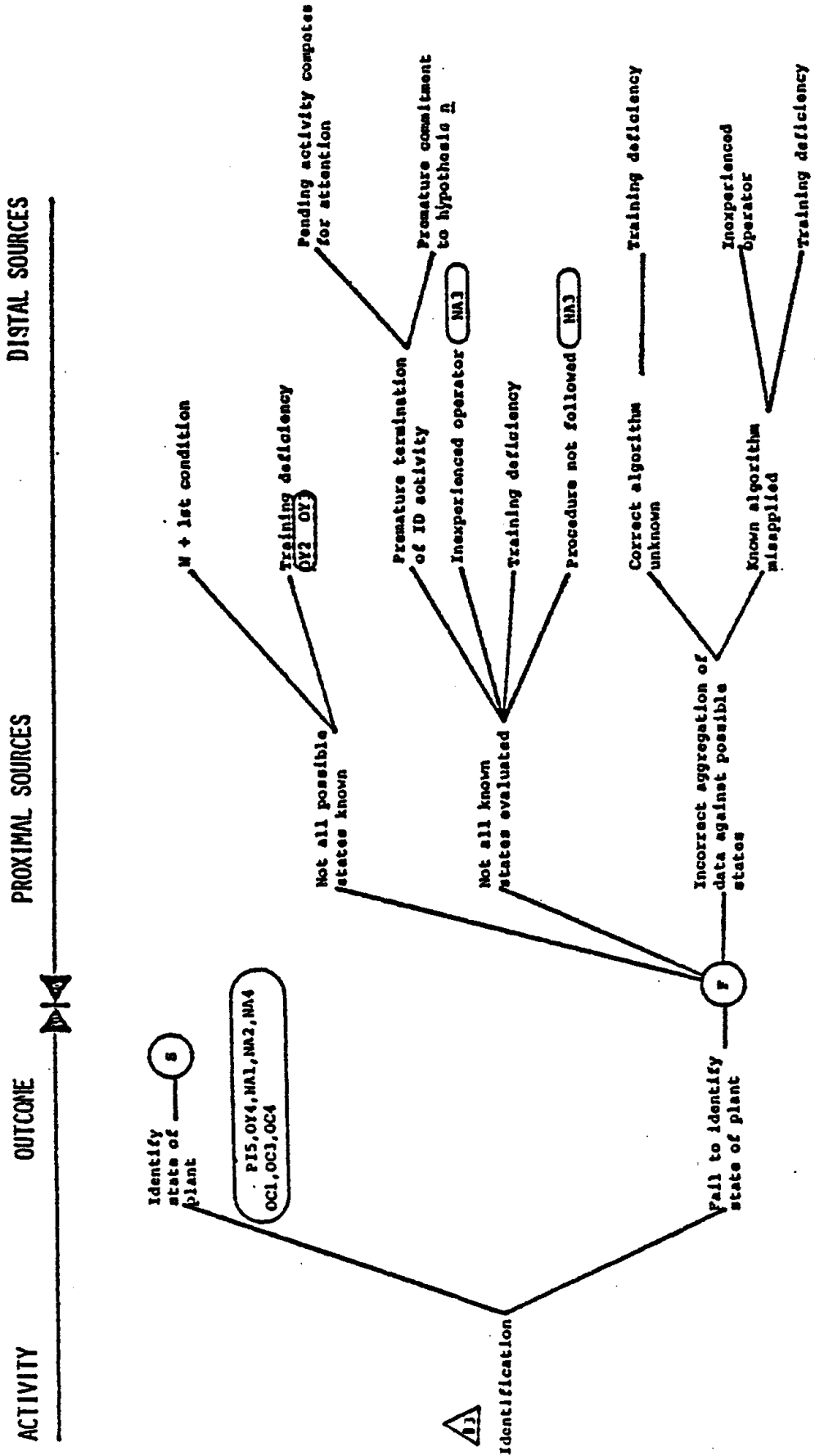

Fig. 18. "Murphy diagram" for the decision process of "identification". Reproduced from Pew et al. (1981).

ANALYSIS OF TRAINING SIMULATOR PERFORMANCE

The general purpose of a training simulator is, of course, to provide the operator with the knowledge and the skills necessary for controlling the plant. But since a number of human performance sequences adequate to identify "prototypical performance" in off-normal plant situations can only be obtained from high fidelity training simulators, the general purpose may be supplemented by the purpose of investigating operator performance in detail. The purpose of such a theoretical study may be combined with the normal use of a training simulator without interfering with it. And furthermore the inclusion of such a theoretical study may be valuable for the normal use of a training simulator, because it puts more sophisticated means of analysis at the disposal of the instructor without causing any major disturbance in the training schedules. One of the basic functions of the instructor is to aid the trainees in their learning by providing them with a feedback of their performance. This feedback is essentially based on the instructor's systematic evaluation of the performance and the information obtained during the debriefing of the trainee. These sources of data are also important for the theoretical study of operator performance. But since the analyses made in a theoretical study are more detailed than what is normally required of an instructor, it follows that they may improve the feedback which the instructor is supposed to give. And obviously anything which improves the quality of the feedback also contributes to the efficiency of the learning.

The question is often raised whether a detailed investigation of operator performance in a training simulator does not imply that the operators will be rated so that they easily can be compared, group averages computed, etc. The answer to that is that this would lead to an investigation of performance scores rather than the performance itself. And this would have little relevance for neither the instructor's function as a teacher, nor the theoretical study. The reason for this is simply that the parts of the performance which are most important, not

least for the purpose of learning, are those where the operator makes a mistake, e.g., when he does something either incorrect or unexpected. Such situations provide the instructor with the best occasions for giving a detailed feedback, and also the theoretical investigator with material for evaluating his hypotheses. But mistakes are, by virtue of their uniqueness, far better described verbally (i.e., in a qualitative description) than measured quantitatively. (Furthermore any measurement must presuppose a detailed description, and can consequently be no better than that description.) The theoretical investigation is therefore only interested in giving a detailed description of the performance. This description is, however, systematic, i.e., based on a set of concepts and rules for combining them. It is precisely this systematic nature of the qualitative description which can be of assistance to the instructor when he shall give a feedback to the operator. It may, of course, require that he modifies and partly extends the procedures normally used to make the evaluation. But since there is a common purpose, the inclusion of the theoretical study in the use of the training simulator will not interfere with the normal procedure. It will, for all parts, be a help and not a hindrance.

The method discussed in the following paragraphs is a suggestion of how a theoretical investigation of training simulator performance may be carried out. It should be noted that for the instructor's part the analysis will normally stop at the level of the formal description of performance. This is the type of description which the instructor can use for the feedback. For the theoretical investigator, the human factors specialist, the analysis continues to the level of the prototypical performance and the competence. This, however, may be done after the training has been concluded since it is based on the data provided by the formal descriptions of the performance. The method presented here is a combination of the method of Pew et al., and the method developed and used in the Scandinavian NKA/KRU project (Hollnagel, 1979a). A more detailed presentation of the method is given in Hollnagel and Rasmussen, 1981.

The Method

The method is divided into two principal parts, the preliminaries to a simulator session and the actual session. The method as a whole may be described as consisting of several steps, cf. the descriptions in the above mentioned sources. From the work of Pew et al. only the parts concerned with data collection and analysis are considered, since the multi-attribute analysis based on expert judgment is irrelevant for the present purpose.

1. Selection of the events to study

The event sequences to study are selected from the set of transients and disturbances which are used for retraining of skilled operators. To develop the method, it is recommended that one simple and one more complex event are selected for pilot experiment in cooperation with interested training instructors.

2. Description of transient and related operator procedures

A time line description of the transient, i.e. the chain of events in the technical system and the proper operator actions, is prepared from a training simulator print-out of a normal or successful sequence. The time line should include characteristic equipment responses, operator actions together with information available on the display console.

Together with experienced training instructors, typical erroneous operator actions should be identified from prior training sessions and the related plant responses determined. It should be determined whether a generic decision tree can be designed which represents the structure of typical inappropriate operator sequences thereby providing a description of the predicted "prototypical" performance. If so, the "critical decision points" should be identified and the scenario studied to prepare computer recording and replay together with forms to facilitate instructor comments during the transients.

3. Training session

During training session a computer log is recorded with relevant details related to the critical decision points. An example of this is shown in fig. 19. This may be supplemented by analogue types of recording as e.g. the strip-chart record shown in fig. 20. The instructor observes the performance and adds comments on a review format, e.g. the error analysis diagram shown in fig. 21, and on the generic decision tree related to predicted "prototypical" critical decisions.

4. Replay and debriefing

During debriefing the critical decision log is replayed for the operating team, including the operator actions and discussions are recorded. Preformatted guides are used to structure the discussions and interviews to collect information related to the columns of the time line forms recording operator intentions, expectations, and data sources used. The terms used for the time line forms and interviews must be from a terminology familiar to the operating staff, as discussed above.

5. Analysis

From the tape recordings and comments of the instructor, a complete time line description is developed by a human factors analyst and transferred to a description related to the decision sequence model as specified above leading to a formal description of the performance in each case; furthermore, the inappropriate operator decisions should be characterized with respect to the related causes, error mechanisms and performance shaping factors. Guides for analysis in terms of checklists or decision (Murphy) diagrams related to human errors should be prepared, e.g. as proposed for routine event analysis. As there will be a high correlation among the elements of the taxonomy of human errors (see fig. 7) in a set of typical, critical decisions, "Murphy" diagrams prepared for these selected events will probably be very convenient for the instructor's comments and analysis; more so than an open use of the classification systems proposed for use of the taxonomy directly. The guides for analysis could be used also to support instructor debriefing.

OPETUSJAKSON YHTEENVETORAPORTTI

88-12-83 KLO 10.00 SIVU 3

		08.37.09	• S032P001	LAUMOUTIN P BAR	<	0.1300E-
		08.37.48	• RL10L002	SYTTUVEISILII RL10 L	>	2.700
		09.00.21	• SP10E002	GENERAATTORI SP10 EP	>	235.0
		09.03.32	S032P001	LAUMOUTIN P BAR	<	0.1300E-
		09.06.18	YX13X001	REAKTORIN PROSENTTITENO	<	70.00
		09.06.22	• YX13X001	REAKTORIN PROSENTTITENO	<	70.00
		09.06.32	YX13X001	REAKTORIN PROSENTTITENO	<	70.00
			0.0			
09.06.39	NHIRION 012 AKTIV NFOB					
09.08.26	NHIRION 012 PASSIVOINTI NFOB					
		09.09.12	YP10L002	PRINEENTASAAJA L	<	3.300
		09.10.22	• YX13X001	REAKTORIN PROSENTTITENO	<	70.00
		09.12.31	RL30L002	SYTTUVEISILII RL30 L	<	2.300
		09.12.48	SP10E002	GENERAATTORI SP10 EP	>	235.0
		09.13.02	• YP10L002	PRINEENTASAAJA L	<	3.300
		09.14.01	YX13X001	REAKTORIN PROSENTTITENO	<	70.00
		09.15.09	YP10L002	PRINEENTASAAJA L	<	3.300
		09.23.51	• YX13X001	REAKTORIN PROSENTTITENO	<	70.00
		09.23.59	YX13X001	REAKTORIN PROSENTTITENO	<	70.00
09.20.34	JNADYTYE					
	AJASSA SIIRTYNINEN					
09.20.03	KAYNNISTYS					
09.20.22	JADYTYE					
09.20.22	KAYNNISTYS					
09.20.34	JADYTYE					
	AJASSA SIIRTYNINEN					
09.13.06	KAYNNISTYS					
		09.10.04	• RL30L002	SYTTUVEISILII RL30 L	<	2.300
		09.10.04	• SP10E002	GENERAATTORI SP10 EP	>	235.0
		09.10.19	• YX13X001	REAKTORIN PROSENTTITENO	<	70.00
		09.12.33	RL30L002	SYTTUVEISILII RL30 L	<	2.300
		09.12.45	SP10E002	GENERAATTORI SP10 EP	>	235.0
		09.14.26	• SP10E002	GENERAATTORI SP10 EP	>	235.0
		09.14.48	YX13X001	REAKTORIN PROSENTTITENO	<	70.00
09.13.39	JNADYTYE					

OPETUSJAKSON YHTEENVETORAPORTTI

88-12-83 KLO 11.12 SIVU 1

OPETUSJAKSON	PCP:n PYSKYTYE JA KAYNNISTYS					
HLKUTILAANNE	AT19 TENOAJA 440 RU 3.12					
SINULSINTIAIKA	KLO 10.03.30 - KLO 11.12.04					
PARAMETRIIT	VAOITGOI REKIVEDEN LAMPUTILA T °	16.0 °C				
	Z261A001 REAKTORIN PALAMO 0-1002	0.0 %				
SEURANTASUUREET		YLARAJA	ALARAJA	MAKSIMI	MINIMI	YLITYKSEIA ALITYKSEIA
YX13X001	REAKTORIN PROSENTTITENO	100.0	70.00	97.99	48.14	0 3
YA10T901	JANADYTYEEN KEKKEI-T	290.0	250.0	280.2	267.9	0 0
YP10L002	PRINEENTASAAJA L	4.000	3.300	4.400	3.192	0 1
Y013L005	NOYRYNKEHITIN Y013 L	2.200	1.960	2.007	2.029	0 0
Y054L005	NOYRYNKEHITIN Y054 L	2.200	1.960	2.007	2.026	0 0
Y013L001	NOYRYNKEHITIN Y013 L	2.200	1.960	2.131	2.053	0 0
Y030T009	OUTLET THERMOCOUPLES	312.0	260.0	285.0	271.4	0 0
R000P901	NOYRYTYKKEI P	40.00	41.00	40.49	42.66	1 0
EL30T004	SYVE EP-ESILANN. JALK	240.0	164.0	223.3	211.6	0 0
RL10L002	SYTTUVEISILII RL10 L	2.700	2.300	2.776	2.412	1 0
RL30L002	SYTTUVEISILII RL30 L	2.700	2.300	2.351	2.050	0 1
THS0L001	ROORISANTYKKAASPO TKSS	2.900	2.000	2.666	2.456	0 0
SP10E002	GENERAATTORI SP10 EP	235.0	207.0	240.0	192.9	1 1
SP50E002	GENERAATTORI SP50 EP	230.0	185.0	232.4	-1.094	3 1
S012L001	LAUMOUTTIREN PINNANKORKE	1.200	0.5000	1.010	0.7792	0 0
S052L001	LAUMOUTTIREN PINNANKORKE	1.200	0.5000	0.8511	0.3530	0 0
S012P001	LAUMOUTIN P BAR	0.3000	0.1500E-01	0.4211E-01	0.2692E-01	0 0
S032P001	LAUMOUTIN P BAR	0.3000	0.1500E-01	0.3711E-01	0.1204E-01	0 1
Y013T001	INJEKTIOVESI TULO P	0.4000	0.1900	0.2867	0.2742	0 0
Y013T004	INJEKTIOVESI SAATS VUOTO	65.00	25.00	42.83	42.81	0 0
B004E001	KYTKINL B0 EU	6.300	0.000	6.344	6.232	0 0

Fig. 19. Examples of computer logs of measured data and operator actions from training simulator.

OPETUSJAKSON YHTEENVETORAPORTTI

80-12-03 KLO 11.12 SIVU 1

OPETUSJAKSON ALKUTILANNE		PCPIN PYSYTYS JA KÄYNNISTYS AT19 TENGAJO 440 RU 3 12				
SINULÖINTIAIKA		KLO 10.03.30 - KLO 11.12.04				
PARAMETRI		VA01001	REKIVEDEN LÄMPÖTILA T °	10.0 °C		
		Z241001	REAKTORIN PALANNO 0-100%	0.0 %		
SEURANTASUUREET		YLARAJA	ALARAJA	MAKSIMI	MINIMI	YLITYKSIÄ ALITUKSIA
YX13X01	REAKTORIN PROSENTTITENO	100.0	70.00	97.99	48.14	0 3
YA10T901	JÄÄHDYTYSEN KESKI-T	290.0	290.0	280.2	267.9	0 0
YP10L002	PAINEENTASAAJA L	4.800	3.500	4.480	3.193	0 1
YB13L005	HÖYRYNKENNITIN YB13 L	2.200	1.960	2.007	2.029	0 0
YB54L005	HÖYRYNKENNITIN YB54 L	2.200	1.960	2.007	2.026	0 0
YB13L001	HÖYRYNKENNITIN YB13 L	2.200	1.960	2.131	2.053	0 0
YB30T009	OUTLET THERMOCOUPLES	312.0	260.0	285.0	271.4	0 0
BA00P901	HÖYRYTUUKKI P	40.00	41.00	40.49	42.66	1 0
RL30T004	SYVE KP-EBILANM. JALK	240.0	164.0	223.3	211.6	0 0
RL10L002	SYTTÖVESISÄILIÖ RL10 L	2.700	2.300	2.776	2.412	1 0
RL50L002	SYTTÖVESISÄILIÖ RL50 L	2.700	2.300	2.551	2.050	0 1
TK50L001	BOORISÄTUNKAARPO TKS0	2.900	2.000	2.666	2.456	0 0
SP10E002	GENERAATTORI SP10 EP	235.0	207.0	240.0	192.9	1 1
SP50E002	GENERAATTORI SP50 EP	230.0	165.0	232.4	-1.094	3 1
SB12L001	LAUHDUTTIMEN PINNANKORKE	1.200	0.5000	1.010	0.7752	0 0
SB52L001	LAUHDUTTIMEN PINNANKORKE	1.200	0.5000	0.8511	0.5550	0 0
SB12P001	LAUHDUTIN P BAR	0.3000	0.1500E-01	0.4211E-01	0.2692E-01	0 0
SB52P001	LAUHDUTIN P BAR	0.3000	0.1500E-01	0.3711E-01	0.1284E-01	0 1
Y913F001	INJEKTIOVESI TULO F	0.4000	0.1900	0.2867	0.2743	0 0
Y913T004	INJEKTIOVESI SAATU VUOTO	63.00	29.00	42.93	42.81	0 0
BA04E001	KYTKINL BA	0.500	4.800	6.364	6.233	0 0

OPETUSJAKSON YHTEENVETORAPORTTI

80-12-03 KLO 10.00 SIVU 3

09.07.09	•	SP52P001	LAUHDUTIN P BAR	<	0.1500E-01
09.07.40	•	RL10L002	SYTTÖVESISÄILIÖ RL10 L	>	2.700
09.08.21	•	SP10E002	GENERAATTORI SP10 EP	>	235.0
09.07.32	•	SP52P001	LAUHDUTIN P BAR	<	0.1500E-01
09.06.10	•	YX13X01	REAKTORIN PROSENTTITENO	<	70.00
09.06.22	•	YX13X01	REAKTORIN PROSENTTITENO	<	70.00
09.06.32	•	YX13X01	REAKTORIN PROSENTTITENO	<	70.00
09.07.29	•	RL10L002	SYTTÖVESISÄILIÖ RL10 L	>	2.700
09.09.12	•	YP10L002	PAINEENTASAAJA L	<	3.500
09.10.22	•	YX13X01	REAKTORIN PROSENTTITENO	<	70.00
09.12.31	•	RL50L002	SYTTÖVESISÄILIÖ RL50 L	<	2.300
09.12.40	•	SP10E002	GENERAATTORI SP10 EP	>	235.0
09.13.02	•	YP10L002	PAINEENTASAAJA L	<	3.500
09.14.01	•	YX13X01	REAKTORIN PROSENTTITENO	<	70.00
09.15.09	•	YP10L002	PAINEENTASAAJA L	<	3.500
09.23.51	•	YX13X01	REAKTORIN PROSENTTITENO	<	70.00
09.23.59	•	YX13X01	REAKTORIN PROSENTTITENO	<	70.00
09.20.34		JÄÄDYTYS			
09.20.03		AJASSA SIIRTYNINEN			
09.20.22		KÄYNNISTYS			
09.20.22		JÄÄDYTYS			
09.20.22		KÄYNNISTYS			
09.20.54		JÄÄDYTYS			
09.15.04		AJASSA SIIRTYNINEN			
09.15.04		KÄYNNISTYS			
09.10.04	•	RL50L002	SYTTÖVESISÄILIÖ RL50 L	<	2.300
09.10.04	•	SP10E002	GENERAATTORI SP10 EP	>	235.0
09.10.19	•	YX13X01	REAKTORIN PROSENTTITENO	<	70.00
09.12.33	•	RL50L002	SYTTÖVESISÄILIÖ RL50 L	<	2.300
09.12.45	•	SP10E002	GENERAATTORI SP10 EP	>	235.0
09.14.26	•	SP10E002	GENERAATTORI SP10 EP	>	235.0
09.14.48	•	YX13X01	REAKTORIN PROSENTTITENO	<	70.00
09.13.39		JÄÄDYTYS			

Fig. 19 cont.

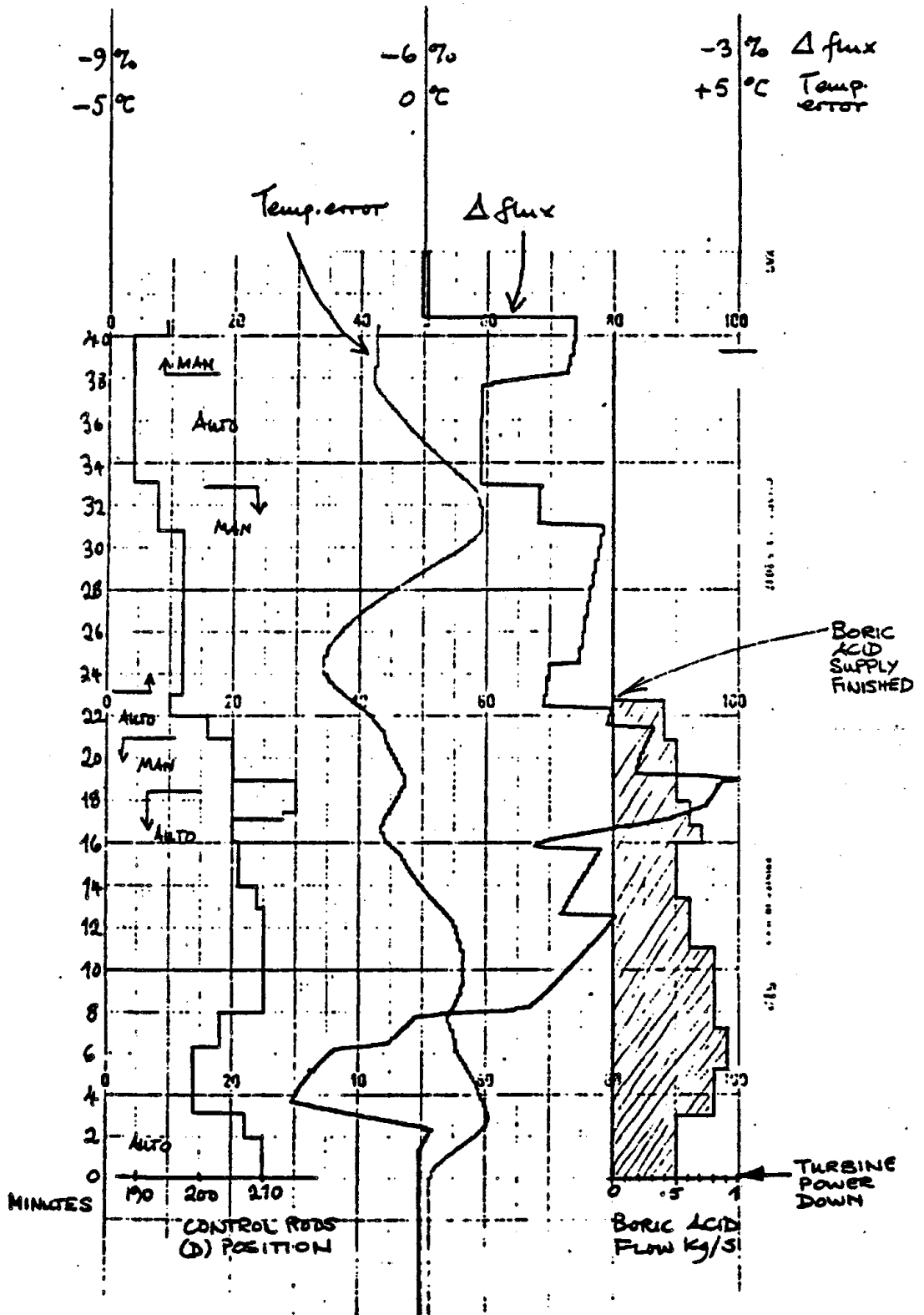

SUBJECT 3

Fig. 20. Strip chart recordings from training simulator.

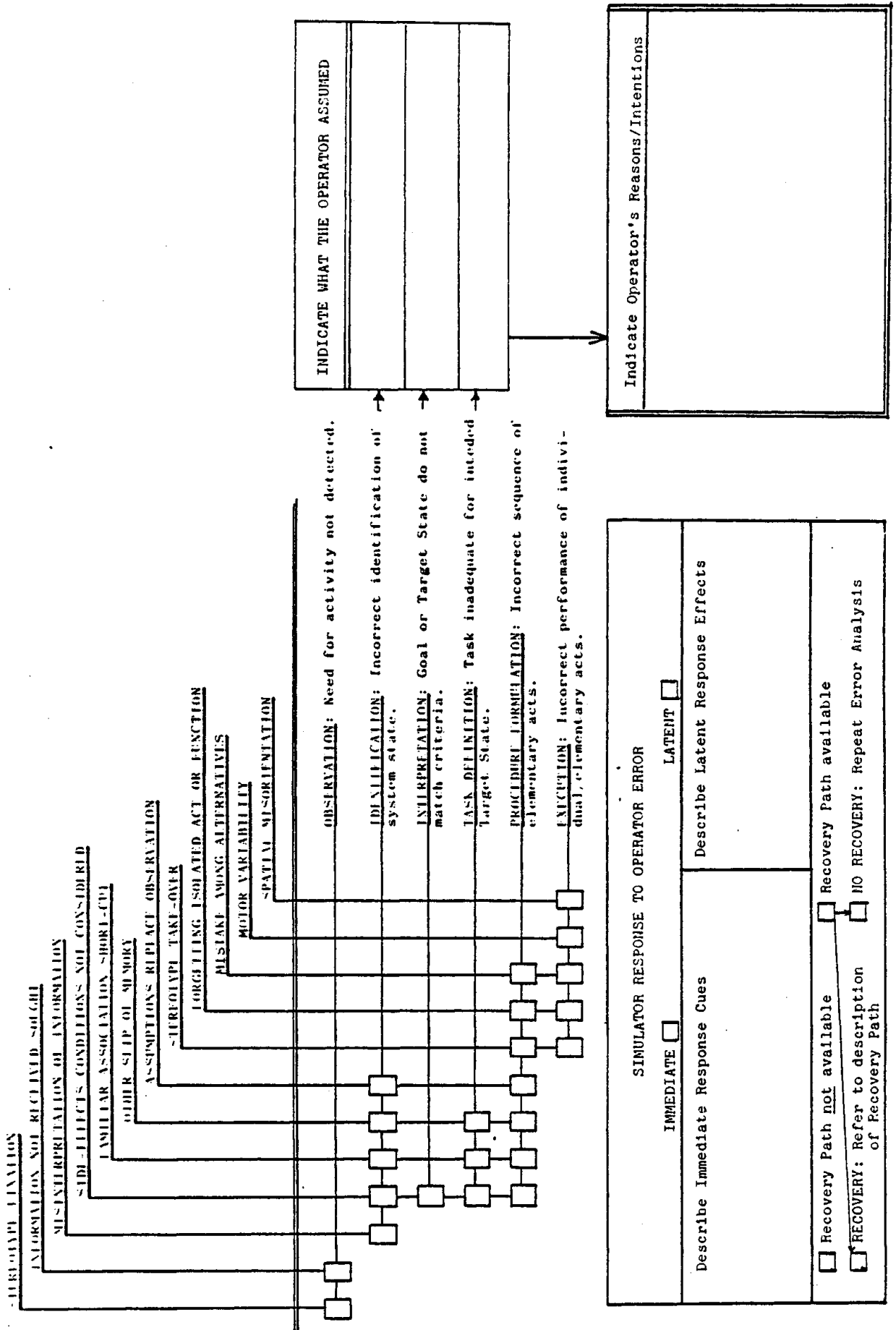

Fig. 21. Graphic format for quick-check record of operator errors during training simulator performance.

6. Feedback

The result of the analysis must, of course, be provided as a feedback to the team of operators which participated in the session, and their comments and conclusions should be recorded.

In addition to this, however, the result of the analysis should be regarded as a general feedback from the performance which may assist the instructor in his job of supervising the training of the operators. Since the purpose of using the training simulator in general is to give the operators a high degree of proficiency in handling the plant, especially in off-normal situations, anything which can improve the learning is of value. An essential factor in any kind of learning is the knowledge of results, i.e. the trainee's knowledge of how his performance was evaluated, what he did that was right and what he did that was wrong. The role of the instructor is precisely to provide this knowledge of results. It follows that the more he will be able to produce a detailed and coherent analysis of the performance, and the faster that he is able to do so, the larger will be the influence of it on the training be. The advantage of offering the instructor a sophisticated method for the analysis of training simulator performance should therefore be obvious, the more so as this methodology is designed not to interfere with the normal procedures.

7. Concluding analysis

Based on a sample of reasonable size, correlative study of the formal descriptions of the recorded cases should be performed, relating the different aspects contained in a multi-facet description of the events, and the successful prototypical performance should be identified as a frame of reference for variants in actual performance and for "errors", as discussed in a following section.

Comments

The analysis proposed here is aiming at an analysis which can be performed during normal training sessions, and the result will be depending on a rather standardized data collection and

analysis, designed not to disturb the training. It is, however, reasonable to assume that the analysis needed to give a qualified debriefing of trainees will also be able to give reliable data on more frequent and typical situations. It should be noticed that study of decision making in rare, complex situations as those described by Pew et al. will need careful, individual planning; very extensive and flexible data collection and more freedom to interfere with training simulation operation - a suggestion is given by Hollnagel (1980d) for an experiment in the Nordic NKA/KRU project.

ANALYSIS OF RESEARCH SIMULATOR PERFORMANCE

In addition to the data available in plant events, plant interviews and training simulators, there is also the possibility of gathering data in a more well-defined environment by means of a research simulator. This may be the only means of getting data when one wants to evaluate a specific idea or hypothesis, since it is normally out of question to make any substantial modification of a training simulator. And it is obviously not sensible to change the working conditions (displays, procedures, etc.) in a real plant unless it has been tried out in advance. As mentioned before research simulators may be used to study experimental control rooms based on new concepts, but also to make detailed investigations of operator performance which would otherwise interfere with the normal use of a training simulator. Research simulators may provide data about normal as well as off-normal plant situations.

Research simulators are therefore valuable tools for providing data about particular events or specific aspects of a task which otherwise would be difficult to get hold of. The reason for that can be either that the situation is rare or improbable, or that special techniques for data gathering are required which cannot be implemented in either a training simulator or in the plant. In particular, the events are always

planned by the analyst himself with the purpose of the investigation in mind. Since work in research simulators thus deal with meticulously planned situations, the analysis of the data is primarily concerned with a single or a few situations. This is a point of distinction from the other contexts, and particularly plant events, where the analysis is based on a number of similar situations. Thus the analysis of data from research simulators is inherently of a qualitative analysis rather than of a quantitative one.

Since the actual form which an analysis of research simulator data may take will depend upon the situation which is investigated, the following presentation will refrain from going into too many details. Instead we shall try to show how the general steps in the analysis will look in a typical research simulator context. Descriptions of a particular research simulator analysis may be found in a number of reports from the Scandinavian NKA/KRU project, e.g., Hollnagel, 1980a, 1980b, 1981b.

The Method

Just as for the method for the training simulator, the method for the research simulator is divided into several parts. The three major divisions are concerned with the preliminaries to a session, with the actual experimental session, and with the subsequent analysis, respectively. The description will follow the structure of the description given for the training simulator.

1. Selection of the event to study

The event to be studied is, of course, selected from the set of events which can be reproduced on the research simulator. The event may be described by means of a reference situation, i.e. a typical real-life situation which involves some of the crucial aspects under study. The event may further be specified with the purpose of the experiment in mind, e.g. with respect to its feasibility for testing or verifying a particular hypothesis. In any case the event should be neither too easy

nor too difficult for the operator to handle; in the former case nothing would be a problem and in the latter everything would. Neither condition is, of course, satisfactory or desirable from the experimenter's point of view.

2. Selection of the subjects

In the previous cases, plant events, plant interviews, and training simulators, there has been no problem of choosing subjects to be studied. They have rather been provided with the context, so to speak. The selection of subjects is, however, a specific part of the use of a research simulator, so a short discussion seems warranted (a more detailed discussion may be found in Hollnagel, 1980c).

The criteria for selecting subjects are to be found in the purpose of the use of a research simulator. The purpose is generally to study the influence of a specific factor (or set of factors) on the subjects' performance, e.g. their problem solving, diagnosis, decision-making, etc. As explained elsewhere in this report, the performance may be characterized by using the three categories of skill-based, rule-based, and knowledge-based behaviour. Since skill-based behaviour is characterized by not requiring attention, by being readily available, and by being carried out automatically and efficiently, it is clear that the influence of a factor will be hard to detect if the performance is largely skill-based. It is, in fact, only possible if the requirements are increased until the skill brakes down, so that the operator is forced to use rule- or knowledge based behaviour.

If, for instance, a research simulator is used for validation of a new display design, the use of highly skilled plant operators will not be acceptable because their habituation to another control console will interfere with their use of the information presented. Their skills will no longer be valid, and this may furthermore influence their attitudes towards the system. On the other hand, the use of unskilled operators will also pose a problem. First of all they will find themselves in a situation where almost everything is difficult, which means that they will have to attend to the details of the activities

rather than to the details of the task. And secondly, in abnormal work situations the effects of the procedural traps formed during long periods of routine tasks cannot be studied.

The criteria for choosing subjects for experiments with research simulators are therefore quite clear, although the actual selection and training of subjects may be rather difficult. We cannot use highly experienced subjects. But on the other hand the subjects must be so familiar with the simulator system that the handling of it does not present a problem. It can further be argued that it is an advantage to use subjects with different, but well documented, backgrounds and different, but known, degrees of experience. In that way one may ascertain with greater certainty whether the assumed influence really exists. Therefore, one should never use just highly experienced operators or non-experienced persons, but rather a mixture of as many types as possible, especially persons with technical plant background, but no operating skills.

3. Description of the incident and expected operator performance

Just as with the training simulators it is advantageous if a time line description of the incident can be prepared in advance.

Planning the time line description related to the task sequence of the reference situation, the basis will be a hypothesis of the operator's internal strategy, his information requirements and performance criteria. This means that a predicted, prototypical performance sequence has to be available. During the actual experiment it is therefore necessary to be prepared to record the relevant interactions with the system and to probe the internal mental activity to be able to identify deviations, i.e. variations as well as errors with respect to the predicted prototypical sequence.

This may be described in analogy with a time line so that one has in advance a basis for evaluating the operator's performance. Based on the prototypical performance and the information about the characteristics of the situation one may develop a

formal description of the performance which can be used in the analysis. It may also be possible to identify in advance the critical decision points.

4. Actual experiment

After the experimental preliminaries have been carried out, the actual experiment can take place. During the experiment data are gathered from the various sources which have been decided in advance. This would typically include a computer log or set of logs, tape-recording of operator comments and operator-experimenter dialogue, comments and observations made by the experimenter aided by the formal description of the performance prepared in advance, as well as various types of special measurements if and when they are required. The data collected during an experiment on a research simulator are usually quite wide ranging.

5. Preliminary analysis

When the experimental session is over, the experimenter has to make a preliminary analysis of the data. In terms of the categories mentioned before, he has to produce a description of the actual performance from the performance fragments gathered during the experiment. The purpose of making this description is to identify the points of the operator's performance which require clarification and further study. This will more or less correspond to the points where the operator's performance, i.e. the actual performance, is different from the expected performance. The operator may e.g. have failed to attend to some of the information or may have chosen an activity which is not immediately comprehensible. Since the experimental design calls for the carrying out of the actual experiment and the experimental replay with as short an interval as possible, the experimenter does not have very much time for the preliminary analysis. It will certainly be in the order of hours rather than days.

6. Experimental replay

During the experimental replay or playback the operator is confronted with selected portions of the actual experiment. This technique is therefore also known as the confrontation-method, although that term is somewhat misleading. During the actual experiment a continuous series of snapshots have been stored by the computer. These may now be used to start the replay at any desired point in time and to initiate the simulator to continue from there. By means of this technique the operator has an almost perfect assistance for recalling what he did during the experiment. He may, therefore, explain to the experimenter his reasons for a particular action, what he attended to, what he had as a goal, etc. This method of aided retrospection is far different from a simple recall, since there is ample possibility for the operator to check and control what he remembers, and to get hints which can aid his memory. During this experimental replay a tape recording of the operator-experimenter dialogue can be made to assist the experimenter during the subsequent, final analysis.

7. Final analysis

After the experimental replay a formal description of the operator's performance may be given, and the actual performance in formal terms can be compared to the predicted performance. For the individual formal sequences deviations from predictions of information requirements and use of display facilities should be analysed carefully to understand the underlying mechanisms. It may be necessary to modify the predicted prototypical performance, due to operator's adoption of a different performance criterion etc. In other words, the individual sequence must be used to identify controlling parameters before several sequences are used to validate the overall hypothesis on prototype performance/display formats. This is typically done after a number of experiments with different subjects in order to have as large a sample of actual performances as possible. The final analysis is, of course, greatly helped by the data from the experimental replay, since during this the experimenter has (hopefully) cleared up any

points of doubt. During the final analysis the results will be transformed into a description of the prototypical performance and further on to a competence description. Examples of this can be found in the following section. However, a summary of the various data formats may be worthwhile to illustrate the descriptions of the analysis:

The raw data from a research simulator will be a set of computer logs and performance measurements; this will include loggings of operator-system interaction, selection of displays (type and duration), system status, alarm status, etc., see fig. 22. There will further be a tape recording of the operator's comments during the experiment (the "think-aloud" protocol) including any dialogue with the experimenter, fig. 23, as well as a tape recording of the retrospective comments produced during the replay of self-confrontation. And there will finally be whatever observations and evaluations the experimenter may have made during or after the experiment/experimental replay; these may be based on pre-formatted checklists designed with the particular situation in mind. The raw data will cover the whole experiment but may possibly be sampled with greater frequency during expected critical parts of it.

The intermediate data format or description of the actual performance will be in two basically different forms. One will be a complete time line which orders the data contained in the various computer logs along a single time line, fig. 24, possibly supplemented by a more detailed critical time line. The other will be the transcribed protocols which combine the data from the think-aloud protocol and the replay protocol, fig. 25. This will typically be as an annotated verbal description ordered along a time line. Both of these forms will describe the actual performance, although each will do it in its own way.

The analysed event data or the description of the formal performance will also be in two different forms which correspond to the forms of the intermediate data format. One will be a complete time line which includes the hierarchical structure of the activities. This means that the basic activities will be

ELAPSED TIME	SOURCE	MOD	DATA	YAI0M1 MU	SF10E1 MU	SP20F1 MU	YAI0J1 PPH	YAI0H4 Z	YAI0DX X	YAI0DM1 X	YAI0DM2 Z	YAI0BT CELS	YAI0L1 Z	YBI0L1 Z
00:18:00	CLOCK		08.50.34	1152.7	0.0	401.9	822.2	54.3	-18.6	118.1	109.0	400.8	42.2	64.8
00:18:18	FUNC.KEYB	1	PC TREND											
00:18:24	FUNC.KEYB	1	NEXT PAGE											
00:18:30	FUNC.KEYB	1	NEXT PAGE											
00:18:33	CLOCK		08.51.02	1140.8	0.0	401.5	822.2	53.5	-18.7	118.4	109.0	400.8	41.9	64.7
00:18:42	FUNC.KEYB	1	FS TREND											
00:18:48	FUNC.KEYB	1	NEXT PAGE											
00:18:53	FUNC.KEYB	1	NEXT PAGE											
00:19:00	CLOCK		08.51.40	1109.3	0.0	401.3	822.2	52.1	-18.7	118.7	109.2	400.8	41.5	64.3
00:19:06	FUNC.KEYB	1	NEXT PAGE											
00:19:04	FUNC.KEYB	1	NEXT PAGE											
00:19:06	FUNC.KEYB	1	NEXT PAGE											
00:19:08	FUNC.KEYB	1	FREV PAGE											
00:19:13	FUNC.KEYB	1	FREV PAGE											
00:19:19	FUNC.KEYB	1	FS TREND											
00:19:30	CLOCK		08.52.22	1082.7	0.0	401.4	822.2	50.8	-18.8	118.7	109.1	400.8	41.3	64.4
00:20:00	FUNC.KEYB	1	PC BARGRAPH											
00:20:10	CLOCK		08.52.59	1051.5	0.0	401.5	822.2	49.2	-18.7	119.1	109.1	400.8	41.0	64.8
00:20:10	CLOCK		08.53.34	1024.1	0.0	401.5	822.2	48.2	-18.5	119.4	109.1	400.8	40.7	64.8
00:21:00	CLOCK		08.54.07	992.1	0.0	401.5	822.2	47.3	-18.1	119.5	109.1	400.8	40.4	64.9
00:21:00	FUNC.KEYB	1	TURB. GEN.											
00:21:30	CLOCK		08.54.37	947.9	0.0	401.5	822.2	44.4	-17.9	119.9	109.1	400.8	40.1	64.9
00:22:00	CLOCK		08.55.07	935.7	0.0	401.5	822.2	45.1	-17.4	119.9	109.1	400.8	39.8	65.0
00:22:30	CLOCK		08.55.37	913.6	0.0	401.2	822.2	41.8	-17.4	120.2	109.1	400.8	39.4	65.3
00:23:00	CLOCK		08.56.08	892.4	0.0	400.4	822.2	43.4	-17.1	121.3	109.3	400.8	38.5	65.2
00:23:30	CLOCK		08.56.38	882.7	0.0	399.7	822.2	42.9	-17.0	122.4	109.5	400.8	37.1	65.7
00:24:00	CLOCK		08.57.08	885.4	0.0	399.4	822.2	42.9	-17.0	123.0	109.5	400.8	35.8	66.0
00:24:17	IRAC FALL		11/43											
00:24:23	FUNC.KEYB	1	INCREASE											
00:24:23	FUNC.KEYB	1	DECREASE											
00:24:30	CLOCK		08.57.38	888.2	0.0	399.6	822.2	42.9	-17.1	123.0	109.4	400.8	34.4	66.1
00:25:00	CLOCK		08.58.08	890.7	0.0	399.8	822.2	42.9	-17.2	124.9	109.3	400.8	32.7	66.1
00:25:30	CLOCK		08.58.38	892.8	0.0	399.8	822.2	42.9	-17.3	125.4	109.3	400.8	32.0	66.1
00:26:00	CLOCK		08.59.08	894.4	0.0	400.0	822.2	42.9	-17.3	124.2	109.2	400.8	31.3	66.1
00:26:30	CLOCK		08.59.38	894.0	0.0	400.1	822.2	43.4	-17.7	124.9	109.2	400.8	30.4	66.2
00:27:00	CLOCK		09.00.08	902.7	0.0	400.8	822.2	43.8	-17.8	124.3	108.8	400.8	30.5	66.5
00:27:30	CLOCK		09.00.38	914.8	0.0	400.8	822.2	43.8	-17.8	124.3	108.8	400.8	30.5	66.5

ELAPSED TIME	SOURCE	MOD	DATA	YAI0M1 MU	SF10E1 MU	SP20F1 MU	YAI0J1 PPH	YAI0H4 Z	YAI0DX X	YAI0DM1 X	YAI0DM2 Z	YAI0BT CELS	YAI0L1 Z	YBI0L1 Z
00:27:44	FUNC.KEYB	1	INCREASE											
00:27:53	FUNC.KEYB	1	DECREASE											
00:27:55	FUNC.KEYB	1	INCREASE											
00:28:00	CLOCK		09.01.08	914.2	0.0	401.0	822.2	43.8	-17.7	124.3	108.8	400.8	30.6	66.3
00:28:07	FUNC.KEYB	1	INCREASE											
00:28:11	FUNC.KEYB	1	INCREASE											
00:28:14	FUNC.KEYB	1	INCREASE											
00:28:18	FUNC.KEYB	1	INCREASE											
00:28:28	CLOCK		09.01.38	911.7	0.0	400.9	822.2	43.8	-17.7	124.4	108.8	400.8	30.6	66.3
00:28:30	FUNC.KEYB	1	INCREASE											
00:28:30	FUNC.KEYB	1	INCREASE											
00:29:00	CLOCK													

Fig. 22. Sample of a computer record of a research simulator.

effective in terms of the flow.)

0225 S Hmm.

0233 S But that Pump no. 3 there, it is less than Pump no. 2.

E No, the Pumps are equal .

S But that one is running at 100 % and is at 551 (KG/S) and the other one was higher than that. So this one will have to go more than 100 %.

E No, because that is the load, the percent that is the load, the flow there.

0237 S So it can be related to those valves here ?

E Yes, if you close them, then it won't have a very great effect on the flow.

0240 S Well, now this one can take the Boron there, and so I can concentrate on the reduction of effect again.

0241 S This is the flow in each of the Condensators, isn't it ?

E Yes. That is, in the Pumps.

244 S Oh yes, oh yes.

0248 S Well, I should rather concentrate on the Turbines here.

0251 S Well this (i.e. the Thermic Effect) has gone more than 100 down. The Rods haven't gone in, so I can go down a bit faster.

0254 S I would like to see...how much Boron I have gotten in.

0255 S Well, more than half of it. Control Rods are...9 2.

Fig. 23. Sample of the transcript of a verbal protocol from a research simulator.

00:10:23 TARGET TURBINE 1 (TB)
00:10:25 DECREASE

00:11:33 SET MALFUNCTION:
ROD STUCK

00:11:54 DECREASE
00:11:57 DECREASE
00:12:00 DECREASE
00:12:06 RATE TURBINE 1 (TB)
00:12:10 DECREASE
00:12:29 DECREASE
00:12:39 REACTOR CORE

00:12:44 SET MALFUNCTION:
DISABLE PUMP NO. 2

00:12:51 412 ALARM (Y)
LO FLOW COND 2
0 - 125 KG/S.
00:12:51 413 ALARM (O)
LO FLOW COND 2
0 - 100 KG/S
AUTO MINFLOW

00:13:10 FEEDWATER SYSTEM
00:13:30 CONDENSATE
00:14:50 RM32D1 (TB)
00:14:55 OPEN/ON

Fig. 24. Combined event log and alarm log, showing all computer recorded operator-system interactions.

00:19:16 S That means that I must...increase the Boration ?
...And at least start it again.

00:19:20 CVS

00:19:25 BORATE (TB)

00:19:27 OPEN/CN

00:19:30 S And at the same time I will set up the (unintelligible).
(Here the S was probably referring to the Rate of the Boration. He had, however, not yet tried to make a detailed diagnosis of the situation, but acted rather on what he thought was most important at the moment.)

00:19:32 BORON RATE

00:19:36 INCREASE

00:19:36 200 ALARM (Y)
LO OUTFLOW CVS
0.4 - 0.63 KG/S

00:19:38 E Now we have a Low Flow from the CVS...That is, the output.

00:19:38 DECREASE
(This activity was not related to the alarm, but rather to the decrease of the Turbine Rate started at 00:19:02.)

00:19:44 INCREASE
(This command ended the increase of the Boron Rate.)

00:20:02 S Low Flow out...Is it possible to regulate that ?

Fig. 25. Combined event log, alarm log and tape transcript with comments, corresponding to the complete description of actual performance.

grouped according to the strategy of which they were a part. Strategies may, of course, themselves be structured into basic strategies and higher order strategies. This form of description, which may be called an activity diagram, fig. 26, may go as far as including the goals or purposes which the operator had with his strategies, thereby extending the description to include an explanation, fig. 27. The other form of the description of the typical performance will be a predominantly verbal strategy description. This will be based on both the activity diagram and the transcribed protocols, fig. 28. The strategy description will be a verbal characterization of the operator's strategies in the sequence in which they occurred, including an evaluation of their effectiveness and a discussion of the intentions/purposes which the operator had with them.

This formal description of the actual performance will be the basis for judgement of the quality of the present interface formats, etc., but will also be useful for derivation of conceptual descriptions of prototypical performance and competence, as discussed below.

ANALYSIS TO IDENTIFY PROTOTYPICAL PERFORMANCE PATTERNS AND RELATED COMPETENCE CONTENT

The results of the analysis discussed so far of the data from the various sources of human performance information have been formal time line descriptions of human decision making and information processing in terms of a formal decision model and/or characterization of critical, inappropriate decisions and actions in terms of a formal "human error" taxonomy.

From these descriptions of the performance in specific situations, prototypical, generic patterns of performance can be derived from a comparison or overlay of performance during a number of similar task situations. The relation of prototypical performance to work conditions, interface designs and different methods of training can then be studied and compared.

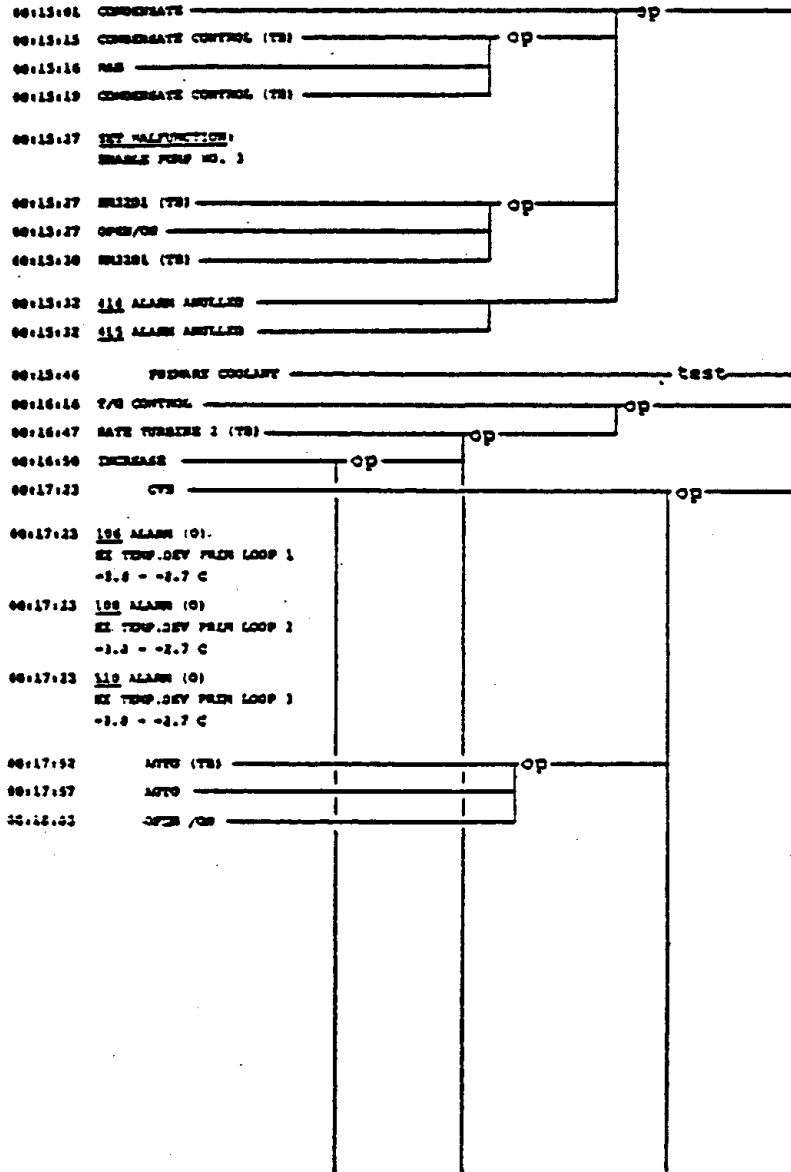
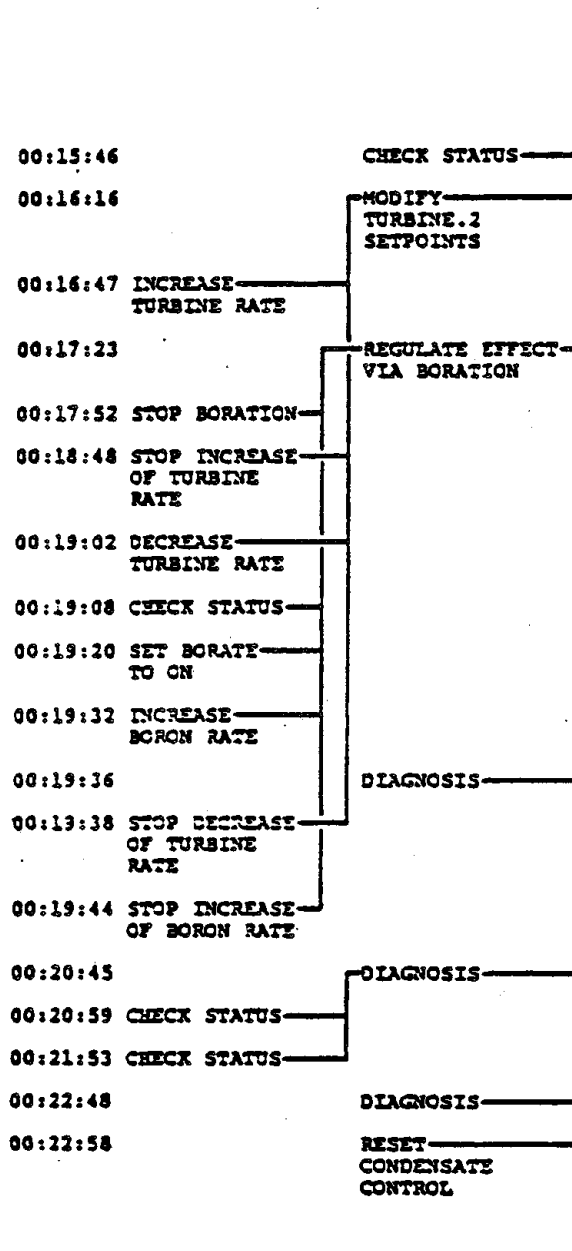

Diagram of Activities for Subject III.8

(page 3 of 16)

Fig. 26. Activity diagram for a subject; this is a formal performance description, cf. fig. 24.



Summary Diagram of Activities for Subject III.B
(page 2 of 3)

Fig. 27. Summary diagram of activities for a subject, is based on the activity diagram of fig. 26.

specific fault.

Preparing the Water Batch (00:13:09-00:14:51). While waiting for the Boration to take effect, the S decided that he had better prepare a Water Batch. He gave two reasons for this, First that it could be useful later on to have it ready if an emergency should arise, since there might not be time left to do it then. He also mentioned that he would leave some 20 kg of Boron for the same reason. Another reason was that he wanted to have a batch ready for the automatic functioning of the CVS. Although this seemed sensible enough it was quite unnecessary since in the Auto mode the Boron and Water needed would be taken from a "hidden" reserve, i.e. not from the Boron and Water Batch displayed in the picture.

Modify Turbine Setpoints (00:14:52-00:16:26). By now the S had decided that the Boration had started to work so that he might begin to reduce the Turbine Effect. He apparently used the TGG Ration, although that had only changed by about 1%. This was hardly noticeable (especially since the S later, at 00:34:06, proved that he was very bad at mental calculation) so the S may in fact have used the reduction in Thermic Effect, which was about 26 MW. He nevertheless used the TGG Ratio to estimate the new Turbine Target, saying that he wanted the sum of the Turbine effects to be about 700 MW ($\approx 2163/3$), since the current Thermic Effect was 2163 MW. He actually reduced the Turbine Target to 313 MW.

Status Check (00:16:44-00:16:50). After having set the new Target for the Turbine the S apparently intended to check the status of the system. He requested the CVS picture, since that would give him information about the Boration, He was, however, interrupted in this by the fast fault. He noticed that the E did something on his terminal, commented on it ("Naughty, naughty ... you have to wait until I have started for real"), and was seconds later alerted by the alarms.

Diagnosis (00:16:59-00:16:59). The S did not use very much time on this diagnosis, but immediately interpreted the alarms to mean that there was something wrong with Condensate Pumps No. 2.

Fig. 28. Description of the subject's strategies; a formal performance description based on the actual performance description, cf. fig. 25.

When prototypical sequences have been identified, the actual performance in a specific case can frequently be described by means of spontaneous jumps between alternative, prototypical ways to deal with a specific task. Such jumps may be caused by acute problems making another strategy preferable, see e.g. Rasmussen, 1979, 1980.

To predict human performance in completely new work environments or in new tasks, it is necessary to characterize human abilities in task and situation independent terms, i.e., to describe human abilities and competence. Such competence descriptions can be derived from performance in actual tasks by abstraction in different ways.

We have chosen to describe the operator's internal background for his performance in information processing terms, i.e., to characterize the mental model, the rules and strategies, and the data coding which operators are able to use, together with the limiting properties of his data processing resources found from error analysis (Rasmussen, 1981).

Methods and data formats suitable for these analyses depend upon the circumstances, and general guidelines cannot be established. For illustrative purposes, some formats which we have found useful in our analysis are discussed below with reference to more detailed publications.

When verbal protocols of good quality are available, graphical representation of the data processing sequence in a time line format can be used for direct visual recognition of recurrent subroutines. This method was used in our analysis of verbal protocols from an electronic maintenance workshop (Rasmussen and Jensen, 1973). The elementary mental operations were identified in a formal language and the protocols coded for computer analysis. The most effective way to identify recurrent routines appeared to be visual analysis of a computer printout of the sequence, see fig. 29.

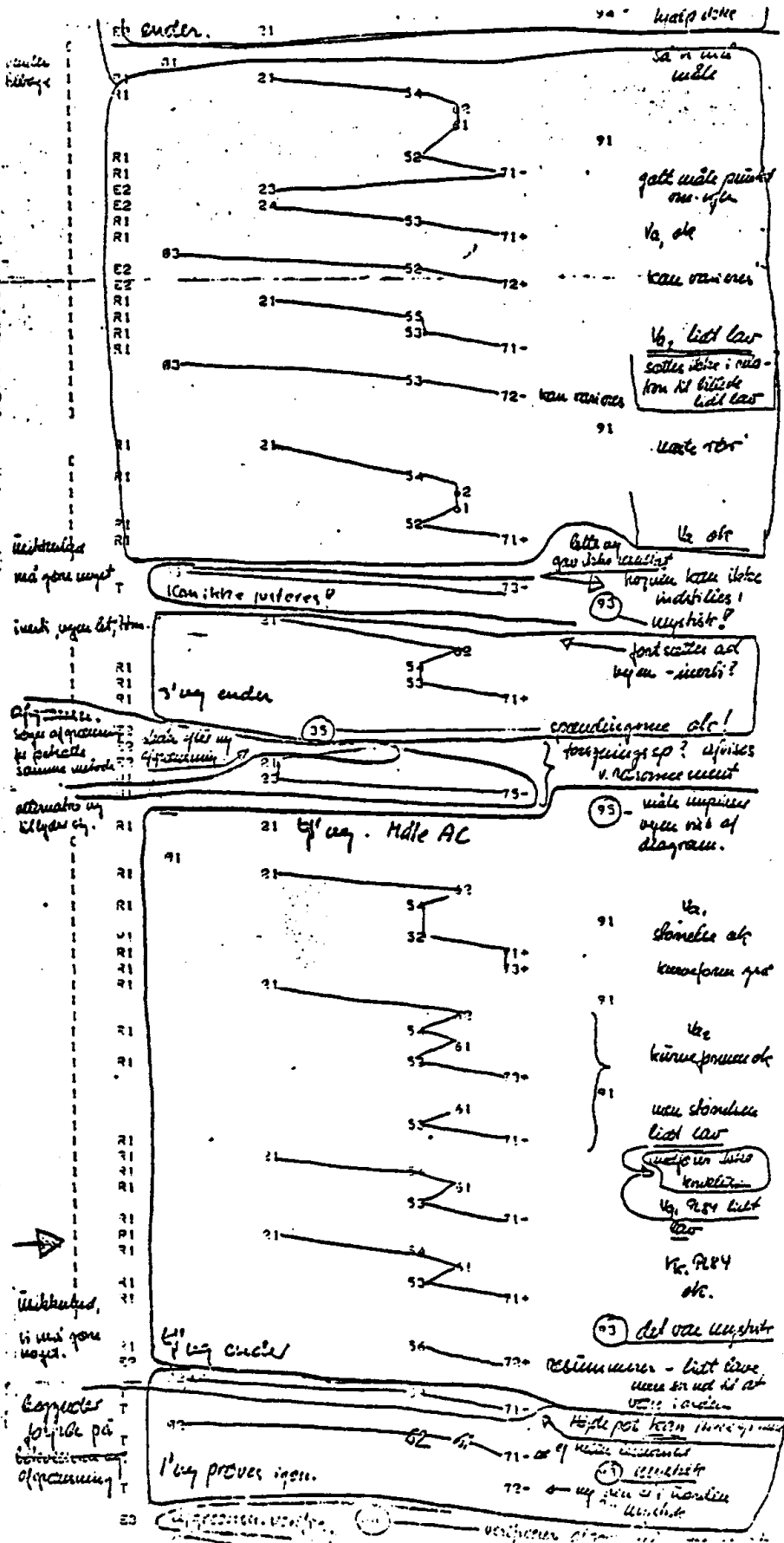

Fig. 29. Sample of a computer print-out of the sequence of elementary operations, used for identification of characteristic recurrent patterns to formulate subroutines. Reproduced from Rasmussen (1973).

Based on the graphic representation, sequences identified as recurrent routines can be found in the original records and the underlying data processing strategy can be identified; and the information flow characteristic of the strategy can be identified, as e.g. shown in fig. 30, together with the data processes and mental models used. By means of symbols for the recurrent strategies, a condensed description of the individual case can be obtained, see fig. 31 representing a case of electronic circuit diagnosis, and the causes for shift among the different strategies can be identified from the original data. The prototypical performance in a given task can then be described by a set of strategic subroutines together with rules and performance criteria to control their sequencing in that specific task.

Verbal protocols from control rooms are less detailed than those obtained from workshops, and are typically sequences of statements of the states of knowledge of an operator, rather than a record of mental data processing activity. However, the pattern of time line descriptions of such sequences of statements are useful to identify subroutines. The format used in our analysis is illustrated in fig. 32 and was used to identify typical shunt paths in the basic decision model of fig. 7. The model of fig. 7 has been used directly as a scratchpad for illustration of overall organization of parts of a protocol, see fig. 33. This representation removed the time dimension but emphasises the information structure. A more systematic representation of this type has been used to represent the hierarchical structure of a task, see fig. 34, Hollnagel, 1979b.

When the verbal protocols record "thinking aloud" sequences, it can be possible to identify the mental models behind the data processes. From protocols in maintenance workshops, computer systems diagnosis, and control rooms we have identified mental models at different levels of abstraction and expressed in different languages (Rasmussen, 1979), as illustrated by fig. 35.

TOPOGRAPHIC SEARCH

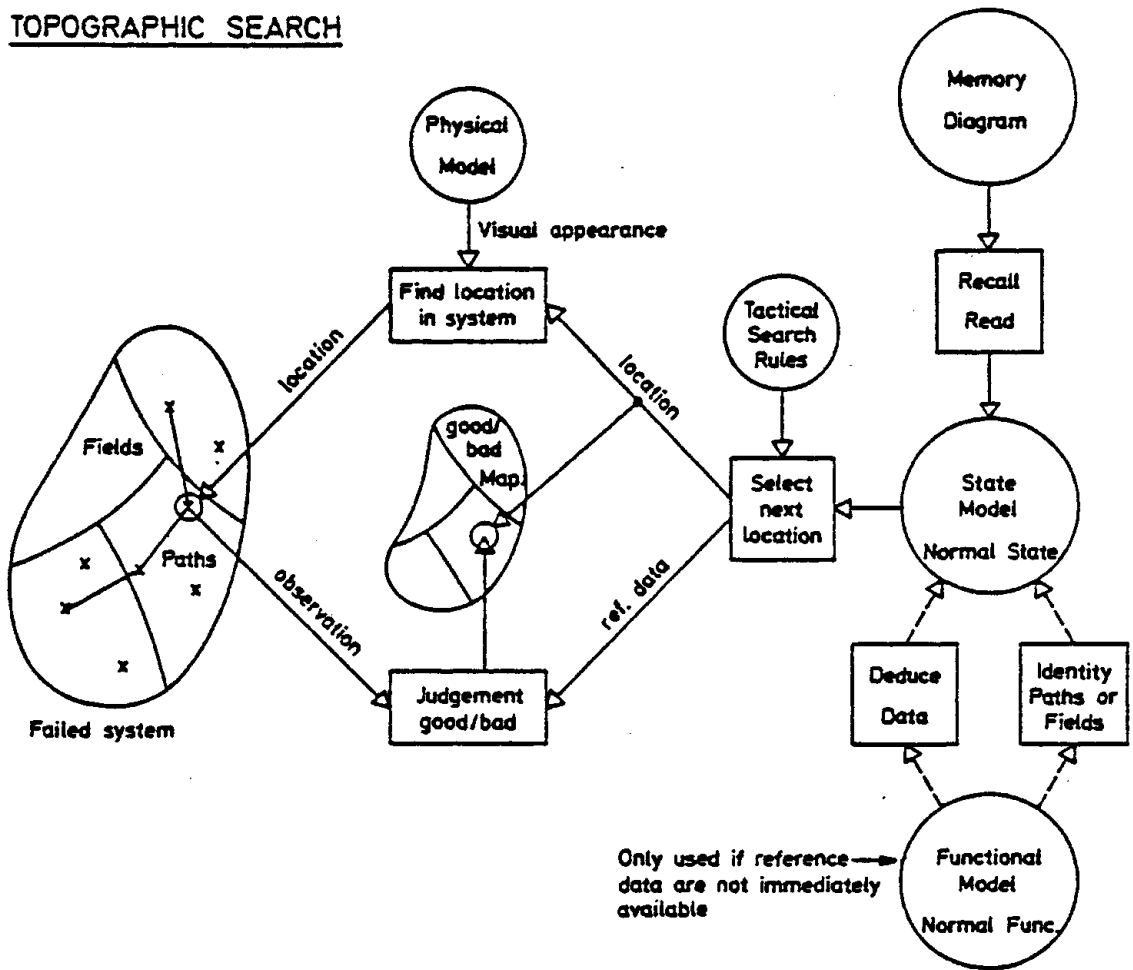

Fig. 30. Schematic diagram of the information flow in a formal diagnostic strategy. Reproduced from Rasmussen (1981).

Oscilloscope

Record No 27

alc. 7-7-71
R2A

Analogue, iches
MAN 2 Diag.
DC & AC norms
Simulated fault.

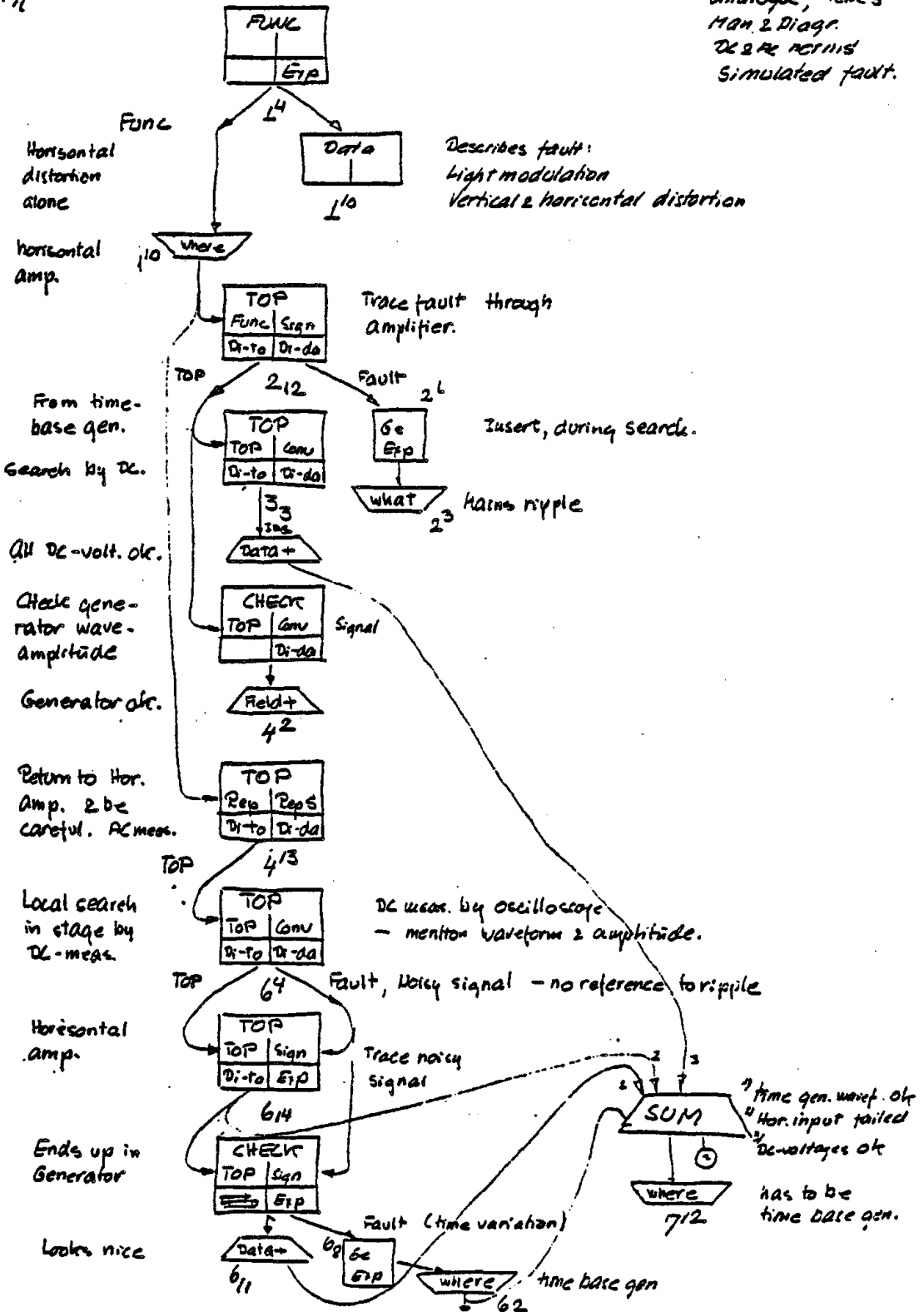

Fig. 31. Sample of a record decomposed into recurrent types of subroutines, showing typical connections between subroutines and the analyst's comments for analysis of the overall pattern. Reproduced from Rasmussen, 1973.

1. Anlægstilstand. ref. til løst opgave

2. Opgave køre termoprobes ind
 reference udvænes - til 4m.
*medring i anlæg.
 op. skal køre for
 at probes er ind*

3 Procedure klar, formuleres kun a.h.t. referat
 trykke på frigiver (op. trykker, giver, stætte,
 give impulse (men han kører ikke)
 stætte kontakter

vekte til den er "ud for 4m" aflæsning i
 forhold til hukket reference?

b tilstand udtrykt ved løst opgave
 observationerne her er check på luftstet
 reference "ud for 4m", men de optreder
 i referat som anlægstilstande - check på
 formuleret opgave.

9 observation i relation til opgave, der optreder
 som tilstand.

10 Observation udløser identifikation i
 handlingstermer.

11 Resumé af tilstand.

12 gentaget i relation til (opgave) betingelser.
 (-rede til handling).

13 observation i "display medie termer"

15 & 12-24

Observationer, hvor tilstand
 direkte aflæses ved check af
 forventninger.

16 opgave formuleret i "handlingstermer"

Her afbrydes af alarm!

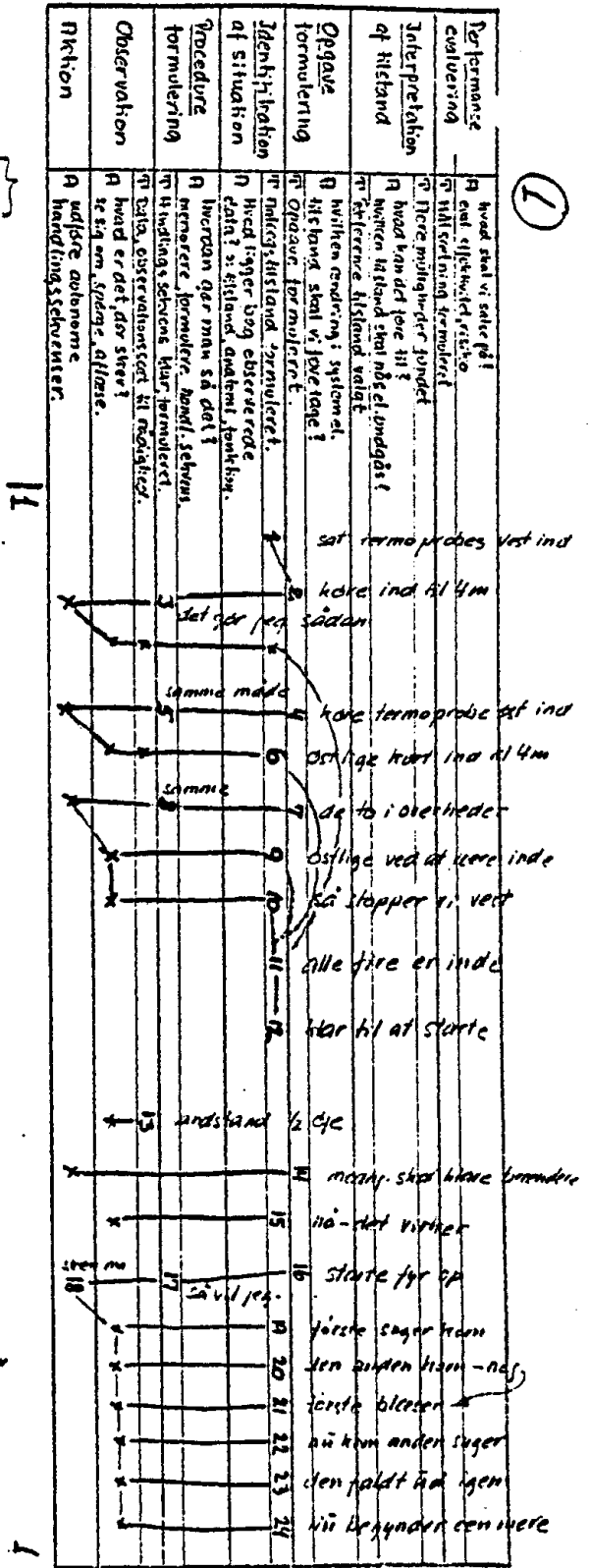

Fig. 32. Time line description of the formal decision making derived from analysis of verbal protocols from power plant control room.

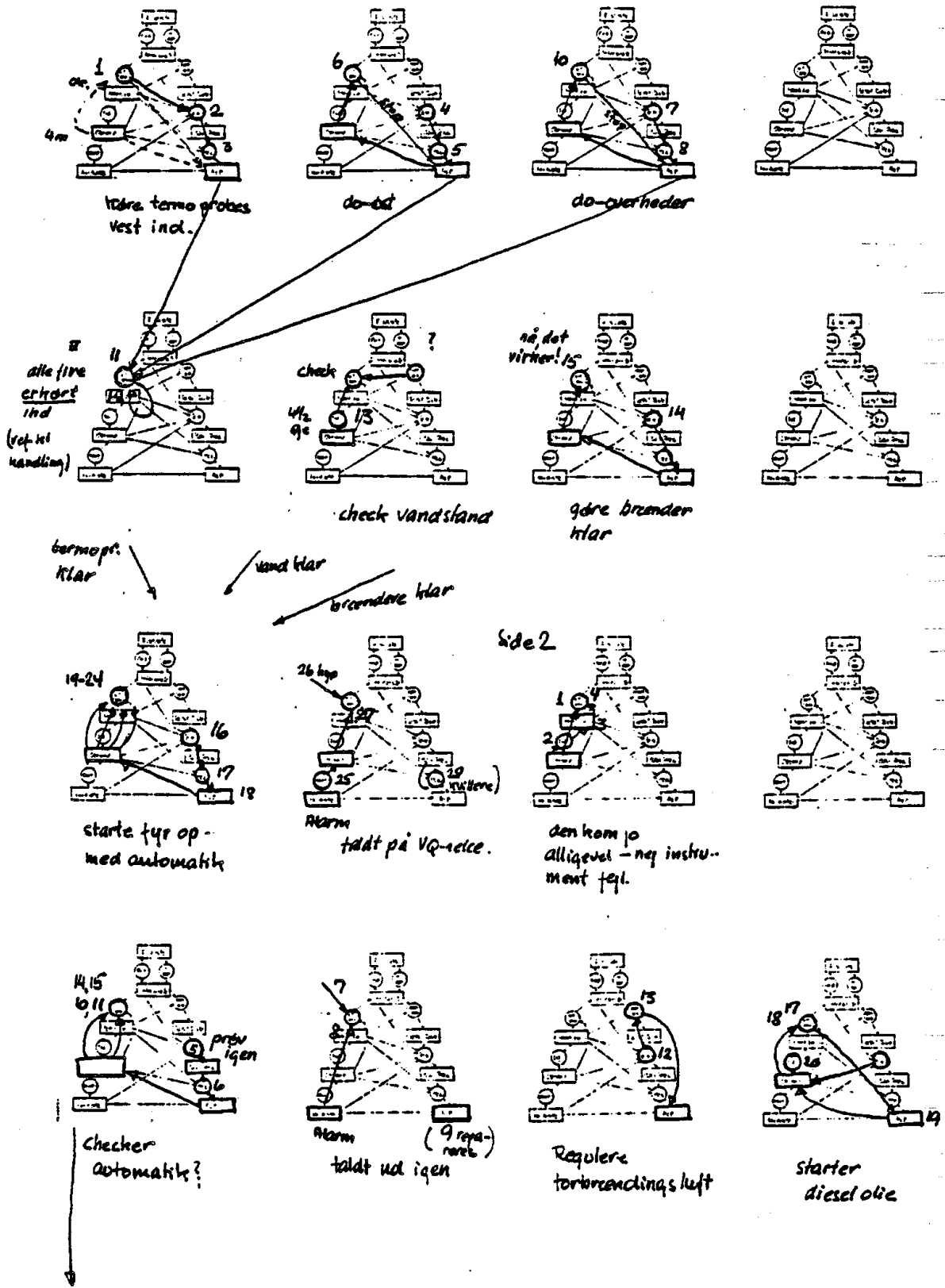

Fig. 33. The use of the ladder-of-abstraction format as sketch pad for analysis of verbal protocols from control room tasks.

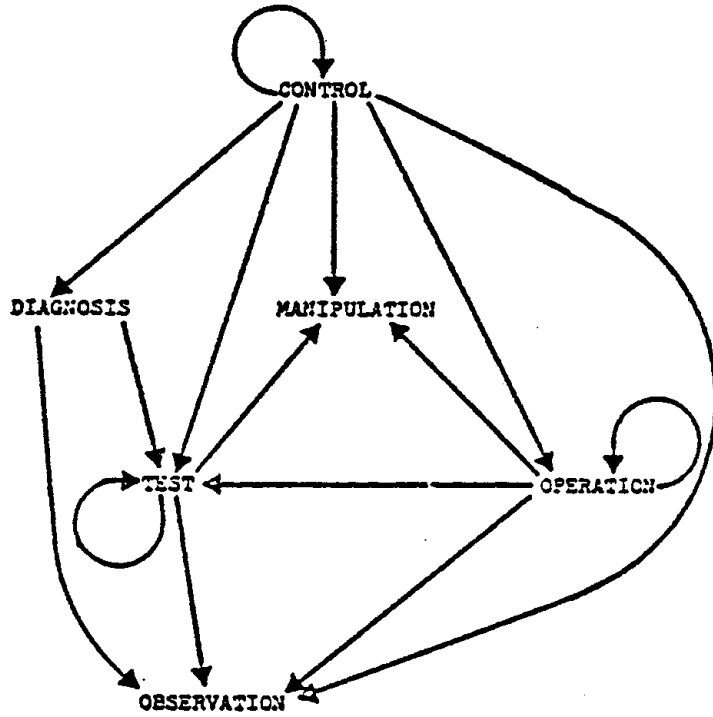

Fig. 34. A generative grammar for basic activity types.

OPERATORS' INFORMATION BASE			
BEHAVIOUR	REFERENCE DATA STATE PATTERN MODELS	STRUCTURES AND RELATIONS FUNCTIONAL MODELS	PROCESS RULES STRATEGIES AND PROCEDURES
GOAL CONTROLLED, MODULIZE BASED	Goals and targets. Performance criteria. Political, business criteria. Set points and reference value figures. Test and calibration figures and patterns. Physical/symbolic transition constants, truth tables, etc. Normal and limiting figures material and process parameters and constants. Normal operational states, fault states. Normal operation figures. Limiting value figures. Normal states, fault patterns. Names and labels of things, components, places.	Value structures. Relations among goals, values. Structure and operation of goal setting organization. Functional meaning. Purpose of functions; control system objectives. Purpose of safety systems and interlocks. Objectives of auxiliary systems. Symbolic function. Energy, mass, information flow causality. Logic functions of control and safety systems. FUNCTIONAL SECTIONS. Variables and their relations. Meter/steam tables, heat transfer laws, neutron physics relations. FUNCTIONAL SECTIONS. Properties of standard functions, their interaction. Criticality, boiling, cooling, water treatment, feedback loops. PHYSICAL FUNCTION. Variables and their relations. Physical characteristics in graphical plots and numerical laws. PHYSICAL FUNCTION. Properties of parts and components. How components work. How they are connected and interact. PHYSICAL FORM. Physical appearance of parts, components, sketches, keys and indicators and their locations. Anatomical and topographic maps.	Mental strategies and heuristic rules for conscious processes: - Deduction, abduction and search. - Explanation, prediction, evaluation. - Planning - i.e. mental experiments, selection and storage of procedure. - Manipulation of symbols; mathematical, graphic. Schematics and drawings. Elements of strategies - the process rules - are system and task independent but model specific.
	GOAL ORIENTED, RULE BASED	State pattern models, references for recognition and identification of states, events, situations, etc.	Associative net relating states, events, situations, needs to tasks or activities. From instruction or experience (or derived by functional reasoning).
MODEL CONTROLLED, SKILL BASED	Templates for activation of reflexive performance by events, objects, situations. "Process-feel".	Subconscious model of physical "landscape". Dynamic world model; schemata for control of bodily and manual activities; Locate, orient attention and body. Move around, manipulate tools, equipment, symbolic aids.	Not relevant

Fig. 35. Schematic illustration of the operator's knowledge basis for an industrial control task. Reproduced from Rasmussen (1979).

However, in general the protocols from control room situations and interviews from simulator seances will not give that degree of detail, and the mental models identified here will be like association networks put together from many isolated statements. Whether these association networks are themselves the basic mental models or they are derived ad hoc from more fundamental models is as yet an open question. Fig. 36 shows such a network derived from a research simulator experiment (Hollnagel, 1981).

For "human error" analysis we have used different formats. When a low number of case stories are analysed, we have found it convenient to use a decision tree structure similar to Pew's Murphy diagrams, see fig. 37. When a large number of cases are analysed, however, a direct coding of the individual cases according to a taxonomy for subsequent computer coding is most effective for search and identification of prototypical patterns and correlations. Figs. 38, 39 and 40 illustrate the taxonomy and formats we have used for analysis of U.S. Licensee Event Reports (Rasmussen, 1980), based on the experience from analysis of 200 reports, the taxonomy has been revised, as shown by fig. 6.

CONCLUSION

The present report is the result of a continuing methodological discussion in our group; we have found it necessary to review and compare the data formats, ways of representing them and tools for analysis. The descriptions given in this report may therefore be different from previously published descriptions - in particular those which have been concerned with specific projects. This has, however, been necessary in order to insure the compability among the different research projects. And this is obviously extremely important if the results from incident analysis, task analysis and simulator experiments should combine to an integrated basis for new systems design.

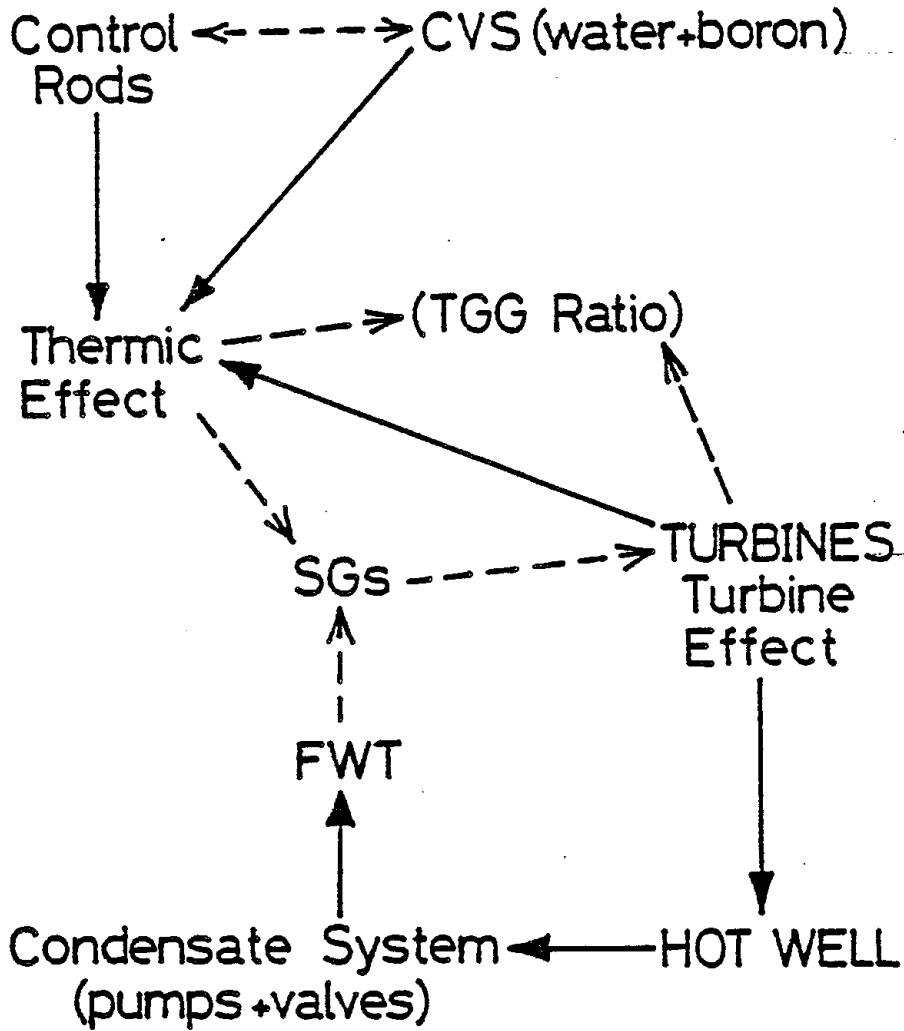

Subject III.C: Summary of relations and components used in the control of the system.

Fig. 36. An associative network representation of the subject's model of the system, based on research simulator data.

Description of operator actions: Operator as supervisor, monitor and decision maker.

Disturbance due to: A. Technical failure

B. Abnormal, non routine, environmental load to plant or operator.

C. Operator action (as functional part of system (reflex actions).)

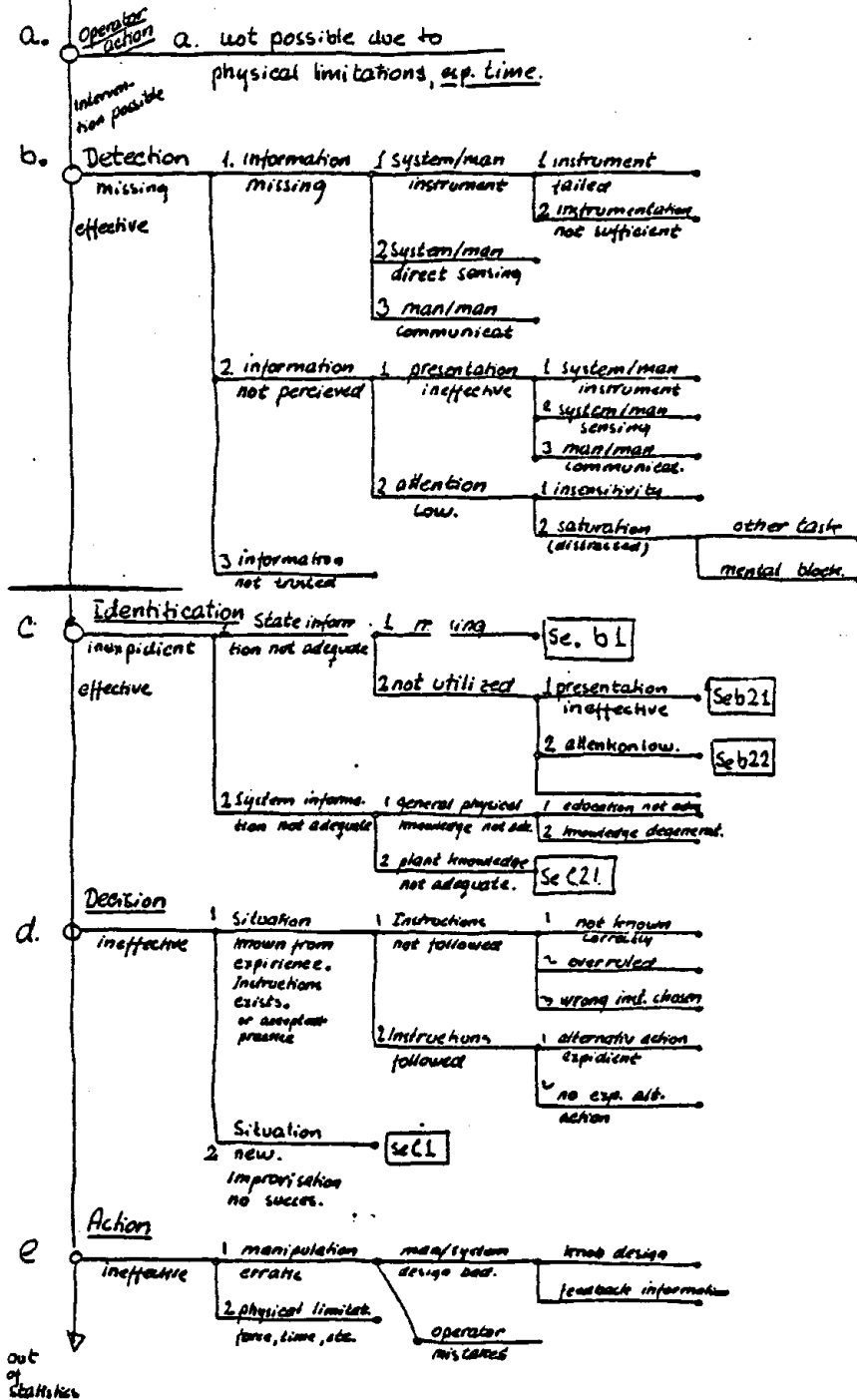

24.4.68
 J. E. S. [Signature]

Fig. 37. Format used to analyse human error in industrial accidents.

Phase of task	ERROR CHARACTERISTICS	ERROR MECHANISMS
Effect from	<ol style="list-style-type: none"> 1. Various, not mentioned 2. Preparation of objects and tools 3. Execution of activity implied in verbal name 4. Restoration, removal of tools, etc. 5. Various, not mentioned 6. Specified, intended target-not <i>not</i> performed 7. Positive effect of wrong act 8. Extraneous effect on other system or activity 9. Sneak path; only "error" due to other human error or unusual knowl^g. 10. Sneak path; only "error" due to tech. faults 	<ol style="list-style-type: none"> 1. Various 2. Absent-mindedness, responds "instinctively" 3. Familiar association short-cut 4. Capability exceeded 5. <i>Alertness low</i> 6. Manual variability, lack of precision 7. Topographic, spatial orientation inadequate 8. Familiar routine interference 9. 10. 11. Omission of functionally isolated act 12. Omission of administrative act 13. Omission; other 14. Mistake, interchange among alternative poss. 15. <i>Expect, assume rather than observe</i> 16. System knowledge insufficient 17. Side effects of proc. not adequately considered 18. Latent causal cond. or relations not adequately considered 19. <i>Relevant data recalled wrong</i> 20. 21. 22. 23. 24. 25.
Recovery	<ol style="list-style-type: none"> 1. Various, not mentioned 2. Effect not immediately (privately) reversible 3. Effect not immediately observable 	
Condition	<ol style="list-style-type: none"> A. Various, not mentioned B. Spontaneous error in undisturbed task C. Change in condition of familiar task D. Operator distracted in task, preoccupied E. Unfamiliar task 	
Common mode	<ol style="list-style-type: none"> F. Number of error repetitions. <ol style="list-style-type: none"> 1. 1, 2, 3, means > 4 	
Task phase	<ol style="list-style-type: none"> A. Various, not mentioned B. Activation, no detection of demand C. Observation, communication D. Identification of system state E. Goal (strategic) F. Target, tactic system state G. Task H. Procedure I. Execution 	
Error in		
Error mechanics		

CASE REPORT	Ref.	No.
PLANT CHARACTERISTICS	<ol style="list-style-type: none"> A. Various B. Reactor BWR C. Reactor PWR D. Chemical plant 	
Plant state	<ol style="list-style-type: none"> 1. Various 2. Power operation 3. State change; start-up, etc. 4. Hot shut-down 5. Cold shut-down, refuelling 	
Equipment	<ol style="list-style-type: none"> A. Various B. Process system C. Instrumentation and control D. Active safety system E. Passive safety barriers F. Auxiliary systems G. Power supplies 	
Task	<ol style="list-style-type: none"> H. Various, not mentioned A. Monitoring and inspection B. Supervisory control, safety actions C. Manual operation; start, stop, change in op. state <i>Hand (c/w)</i> D. Inventory control; fill, drain, purge, etc. E. Test and calibration F. Repair and modification, <i>re-assembly</i> G. Administrative; recording, reporting H. Management, staff planning and control 	
Situation	<ol style="list-style-type: none"> 1. Various, not mentioned 2. Routine task on schedule 3. Routine task on demand 4. Special task on schedule 5. Ad hoc, improvisation 	
Location	<ol style="list-style-type: none"> A. Various, not mentioned B. Control consoles, control room C. In plant, on equipment D. Workshop E. Office, writing desk 	
Instruction	<ol style="list-style-type: none"> 1. Various, not mentioned 2. Instruction satisfactory 3. Written instruction insufficient 4. Written instruction wrong 5. Written instruction non existing 6. Verbal instruction insufficient 7. Verbal instruction wrong 8. 	
Task control	<ol style="list-style-type: none"> A. Various, not mentioned B. Paced by system dynamics - <i>time delay, response of system</i> C. Paced by program, orders D. Self paced 	
Detection by	<ol style="list-style-type: none"> A. Various, not mentioned B. Alarm, safety system action C. Indication in control room D. Other functional effect E. Scheduled test, inspection F. Log review G. "Seen", "found" H. 	
ERROR CHAR.		

Fig. 38. Checklists used for analysis of event reports.

No.	Plant type	Plant state	Equipment	Task	Situation	Location	Instruction	Task control	Detection by	Phase of test	Effect from	Recovery	Condition	Common mode	Task phase	Error in mechanics	Short description
40	C	2	F	E	2	C	1	D	B	3	C	3	B	1	I	M	Control, make up water to limit I instead of 2
41	C	2	C	G	4	C	1	D	G	4	B	3	B	1	H	B	Repair man records system program, not data tape
42	C	1	F	A	1	C	1	A	E	4	C	1	A	3	H	11	Clamps left on valves
43	C	2	F	E	3	C	2	D	B	2	B	3	B	1	H	11	No circulation before sampling.
44	C	5	B	E	4	C	1	D	E	3	C	3	C	1	H	17	Inadvertent release during purging.
45	C	1	D	A	1	C	1	A	C	1	D	1	A	3	I	2	Valves used as stepping points
46	C	5	E	G	2	C	1	A	A	1	C	1	A	1	F	17	Airlock open during repair
47	C	5	D	A	1	C	1	D	G	1	C	1	A	2	I	14	Valves locked closed instead of open.
48	C	1	D	F	2	D	2	D	F	3	B	3	D	3	F	13	Chemistry do not test upper concentration limit.
49	C	1	C	E	2	B	1	D	A	1	B	2	D	1	H	11	No sampling before transfer
50	C	5	F	F	2	C	3	D	E	4	B	3	B	1	H	11	Generator brushes left open after test
51	C	4	B	G	4	C	1	D	C	4	B	3	E	1	H	11	Simulated signal not removed.
52	C	1	B	F	2	C	1	D	F	3	C	3	A	>4	H	18	not aware that flashing cause release when sampling
53	C	5	D	G	4	C	2	D	B	4	B	3	B	1	H	11	Fuses not replaced after repair

Fig. 39. Short-hand format for event analysis.

Distribution across tasks		Distribution across mental task phase		Distribution across error modes	
3 13 17	Monitoring and inspection	1 1 1	1 1 1	1 1 1	1 1 1
3 13 17	Supervisory control	1 3 1	1 1 1	1 1 1	1 1 1
3 13 17	Manual operation and control	2 1 1	1 1 1	1 1 1	1 1 1
30 47 60	Inventary control	3 1 1	1 1 1	1 1 1	1 1 1
30 47 60	Test and calibration	3 1 1	1 1 1	1 1 1	1 1 1
30 47 60	Repair and modification	3 1 1	1 1 1	1 1 1	1 1 1
4 13 13	Administrative task	1 1 1	1 1 1	1 1 1	1 1 1
4 13 13	Management, staff planning	1 1 1	1 1 1	1 1 1	1 1 1
4 13 13	Various; not mentioned	1 1 1	1 1 1	1 1 1	1 1 1
TASK		MENTAL TASK PHASE		ERROR MODE	
Absent-mindedness		Absent-mindedness		Absent-mindedness	
Familiar association		Familiar association		Familiar association	
Alertness low		Alertness low		Alertness low	
Omission of functionally isolated act		Omission of functionally isolated act		Omission of functionally isolated act	
Omissions - other		Omissions - other		Omissions - other	
Mistakes among alternatives		Mistakes among alternatives		Mistakes among alternatives	
Expect, assume - rather than observe		Expect, assume - rather than observe		Expect, assume - rather than observe	
Side effect not adequately considered		Side effect not adequately considered		Side effect not adequately considered	
Latent conditions not adeq. cons.		Latent conditions not adeq. cons.		Latent conditions not adeq. cons.	
Manual variability, lack of precision		Manual variability, lack of precision		Manual variability, lack of precision	
Topographic, spatial orient. weak		Topographic, spatial orient. weak		Topographic, spatial orient. weak	
Various; not mentioned		Various; not mentioned		Various; not mentioned	
3	3	3	3	3	3
6	6	6	6	6	6
10	10	10	10	10	10
68	68	68	68	68	68
17	17	17	17	17	17
11	11	11	11	11	11
10	10	10	10	10	10
15	15	15	15	15	15
20	20	20	20	20	20
10	10	10	10	10	10
10	10	10	10	10	10
20	20	20	20	20	20

Distribution across tasks		Distribution across mental task phase		Distribution across error modes	
11 12 17	Detection of demand	1 1 1	1 1 1	1 1 1	1 1 1
11 12 17	Observation - communication	1 1 1	1 1 1	1 1 1	1 1 1
11 12 17	Identification of system state	1 1 1	1 1 1	1 1 1	1 1 1
5	Goal - strategic decision	1 1 1	1 1 1	1 1 1	1 1 1
5	Target - tactic system state	1 1 1	1 1 1	1 1 1	1 1 1
5	Task - Determine, select	1 1 1	1 1 1	1 1 1	1 1 1
117 36 2	Procedure - plan, recall	1 1 1	1 1 1	1 1 1	1 1 1
117 36 2	Execution	1 1 1	1 1 1	1 1 1	1 1 1
117 36 2	Various	1 1 1	1 1 1	1 1 1	1 1 1
TASK		MENTAL TASK PHASE		ERROR MODE	
Absent-mindedness		Absent-mindedness		Absent-mindedness	
Familiar association		Familiar association		Familiar association	
Alertness low		Alertness low		Alertness low	
Omission of functionally isolated act		Omission of functionally isolated act		Omission of functionally isolated act	
Omissions - other		Omissions - other		Omissions - other	
Mistakes among alternatives		Mistakes among alternatives		Mistakes among alternatives	
Expect, assume - rather than observe		Expect, assume - rather than observe		Expect, assume - rather than observe	
Side effect not adequately considered		Side effect not adequately considered		Side effect not adequately considered	
Latent conditions not adeq. cons.		Latent conditions not adeq. cons.		Latent conditions not adeq. cons.	
Manual variability, lack of precision		Manual variability, lack of precision		Manual variability, lack of precision	
Topographic, spatial orient. weak		Topographic, spatial orient. weak		Topographic, spatial orient. weak	
Various; not mentioned		Various; not mentioned		Various; not mentioned	
3	3	3	3	3	3
6	6	6	6	6	6
10	10	10	10	10	10
68	68	68	68	68	68
17	17	17	17	17	17
11	11	11	11	11	11
10	10	10	10	10	10
15	15	15	15	15	15
20	20	20	20	20	20
10	10	10	10	10	10
10	10	10	10	10	10
20	20	20	20	20	20

Distribution across mental task phase and error mode

Distribution across task and human error mode of 200 reports of "operational problems" in nuclear power plants.

Fig. 40. Two dimensional histograms based on taxonomy of fig. 38.

REFERENCES

- Hollnagel, E. (1979a). The methodological structure of the KRU-experiments: Notes on the nature of qualitative research. Roskilde, Denmark: Risø, Electronics Department N-34-79 (NKA/KRU-P2(79)23).
- Hollnagel, E. (1979b). A framework for the description of operator behavior. Roskilde, Denmark: Risø, Electronics Department N-35-79 (NKA/KRU-P2(79)24).
- Hollnagel, E. (1980a). Report from the second NKA/KRU experiment: The performance of non-professionals in controlling a complex process. Roskilde, Denmark: Risø, Electronics Department N-28-80 (NKA/KRU-P2(80)30).
- Hollnagel, E. (1980b). Report from the NKA/KRU pilot experiment: An evaluation of the use of a qualitative methodology in the investigation of operator performance in complex environments. Roskilde, Denmark: Risø, Electronics Department N-18-80 (NKA/KRU-P2(80)28).
- Hollnagel, E. (1980c). On the validity of simulator studies: Problems and preliminary precepts. Roskilde, Denmark: Risø, Electronics Department N-39-80 (NKA/KRU-P2(80)33).
- Hollnagel, E. (1980d). Suggestions for experiments at the Loviisa Simulator. Roskilde, Denmark: Risø, Electronics Department (mimeo).
- Hollnagel, E. (1981). Report from the third NKA/KRU experiment: The performance of control engineers in the surveillance of a complex process. Roskilde, Denmark: Risø, Electronics Department N-14-81 (NKA/KRU-P2(81)36).
- Hollnagel, E. and J. Rasmussen (1981). Simulator training analysis. Roskilde, Denmark: Risø, Electronics Department N-19-81 (NKA/KRU-P2(81)38).
- Nielsen, D. S. (1974). Use of cause-consequence charts in practical systems analysis. Risø-M-1743. (Presented at the conference on reliability and fault tree analysis.)
- Pew, R. W., D. C. Miller and C. E. Fehrer (1981). Evaluation of proposed control room improvements through analysis of critical operator decisions. Bolt Beranek and Newman Inc., Report No. 4394. To be published.

- Rasmussen, J. and Aa. Jensen (1973). A study of mental procedures in electronic trouble shooting. Risø-M-1582, Risø National Laboratory, Denmark.
- Rasmussen, J. (1974). The human data processor as a system component. Bits and pieces of a model. Risø-M-1722, Risø National Laboratory, Denmark.
- Rasmussen, J. (1976). Outlines of a hybrid model of the process operator. In Sheridan and Johannsen (Eds.) "Monitoring Behaviour and Supervisory Control". Plenum Press, New York.
- Rasmussen, J. (1979). Reflections on the concept of operator workload. In: Moray, N. (Ed.) "Mental Workload". Plenum Publishing Corporation.
- Rasmussen, J. (1979). On the structure of knowledge - a morphology of mental models in a man-machine system context. Risø-M-2192.
- Rasmussen, J. (1980). The human as a system component. In: H. Smith and T. Green (Eds.) "Human Interaction with Computers". Academic Press, London.
- Rasmussen, J. (1980). What can be learned from human error reports. In: Duncan, K., Gruneberg, M., and Wallis, D. (Eds.) "Changes in Working Life". John Wiley & Sons. (Proceedings of the NATO International Conference on Changes in the Nature and Quality of Working Life, Thessaloniki, Greece.)
- Rasmussen, J. (1981). Models of mental strategies in process plant diagnosis. To be published in: Human Detection and Diagnosis of System Failures, J. Rasmussen and W. B. Rouse (Eds.), Plenum Press, New York.
- Rasmussen, J., O. M. Pedersen, G. Mancini, A. Carnino, M. Griffon and P. Gagnolet (1981). Classification system for reporting events involving human malfunctions. Risø-M-2240, SINDOC(81)14.

