

Technical University of Denmark



## Electricity for Road Transport, Flexible Power Systems and Wind Power

**Nielsen, Lars Henrik; Ravn, Hans; Meibom, Peter; Juul, Nina; Hedegaard, Karsten; Larsen, Helge V.; Jørgensen, Kaj; Larsen, Esben; Horstmann, Jørgen Peter Frederik; Nørgård, Per Bromand; Bavnhøj Hansen, Anders; Pedersen, Jens; Kipp, Nicolai Anders; Abildgaard, Hans**

*Publication date:*  
2011

*Document Version*  
Publisher's PDF, also known as Version of record

[Link back to DTU Orbit](#)

*Citation (APA):*  
Nielsen, L. H., Ravn, H., Meibom, P., Juul, N., Hedegaard, K., Larsen, H. V., ... Abildgaard, H. (2011). Electricity for Road Transport, Flexible Power Systems and Wind Power. Roskilde: Danmarks Tekniske Universitet, Risø Nationallaboratoriet for Bæredygtig Energi. (Denmark. Forskningscenter Risoe. Risoe-R; No. 1804(EN)).

## DTU Library

Technical Information Center of Denmark

---

### General rights

Copyright and moral rights for the publications made accessible in the public portal are retained by the authors and/or other copyright owners and it is a condition of accessing publications that users recognise and abide by the legal requirements associated with these rights.

- Users may download and print one copy of any publication from the public portal for the purpose of private study or research.
- You may not further distribute the material or use it for any profit-making activity or commercial gain
- You may freely distribute the URL identifying the publication in the public portal

If you believe that this document breaches copyright please contact us providing details, and we will remove access to the work immediately and investigate your claim.

# Electricity for Road Transport, Flexible Power Systems and Wind Power

Risø-R-Report

Edited by Lars Henrik Nielsen and Hans Ravn  
Risø-R-1804 (EN)  
December 2011

Risø DTU  
National Laboratory for Sustainable Energy

---



**Author:** Lars Henrik Nielsen, Hans Ravn et al.  
**Title:** Electricity for Road Transport, Flexible Power Systems and Wind Power  
**Division:** Systems Analysis Department, Risø DTU National Laboratory for Sustainable Energy

**Abstract:**

This report is a result of the project: Electricity for Road Transport, Flexible Power Systems and Wind Power. The aim of the project is to analyse the potential synergistic interplay that may arise between the power sector and the transport sector, if parts of the road transport energy needs are based on electricity via the utilisation of plug-in hybrid electric vehicles and pure electric vehicles.

The project focuses on the technical elements in the chain that comprises: 1: The electric vehicle status, potentials and expected development. Electric batteries are in focus in this part of the analysis. 2: Analysis of plug-in hybrid electric vehicle interacting with a local grid. 3: Analysis of grid-vehicle connection systems including technical regulation options and analysis of needs for standardisation. 4: Setting up scenarios covering potential developments for utilizing electric drive trains in road transport. Period: Up to year 2030. 5: Analysis of capacity constraints in the electricity grid (transmission and distribution) as consequence of increasing electricity demand, and new flexible consumption patterns from segments in the transport sector, and as consequence of increasing capacity on wind power in the system. 6: Setting up and analysis of combined scenarios covering both the heat and power system and the transport sector.

**Report number:** Risø-R-1804 (EN)  
**Publication date:** December 2011

**ISSN 0106-2840**  
**ISBN 978-87-550-3963-6**

**Contract no.:** (DENP) Journalnr.:  
**33033-0218**

**Group's own reg. no.:** 1200235

**Sponsorship:** EUDP and project partners

**Pages:** 144  
**Figures:** 73  
**Tables:** 13  
**References:** 72

Information Service Department  
Risø National Laboratory for Sustainable Energy  
Technical University of Denmark  
P.O.Box 49  
DK-4000 Roskilde  
Denmark  
Telephone +45 46774005  
[bibl@risoe.dtu.dk](mailto:bibl@risoe.dtu.dk)  
Fax +45 46774013  
[www.risoe.dtu.dk](http://www.risoe.dtu.dk)

# Contents

<b>1</b>	<b>Executive summary</b>	<b>14</b>
1.1	Scenario analyses	14
1.2	Transport sector aspects	15
	Electric Vehicles substituting conventional vehicles in road transport.	15
	<i>Relative cost of ownership: BEV, PHEV and HEV relative to ICEV</i>	15
	EV fleet development substituting conventional ICEV road transport.	17
1.3	Power sector and grid aspects	23
1.4	Overall transport and power system aspects	24
	Discussion	26
<b>2</b>	<b>Introduction</b>	<b>27</b>
2.1	Background	27
2.2	Recent developments in electric vehicles	29
2.3	This project	29
2.4	Report structure	29
<b>3</b>	<b>The electric vehicle (EV) status and expected development</b>	<b>31</b>
3.1	Road transport vehicles in focus	31
	Level of vehicle description	31
	Annual driving	32
	Issues in focus	32
3.2	Assumptions on vehicle energy consumption	32
	Vehicle comparisons: Specific energy consumption	33
	PHEV: 77% of annual driving via Electricity	34
3.3	Assumptions on vehicle CO <sub>2</sub> emission	35
	EV CO <sub>2</sub> emission per km: CO <sub>2</sub> Case I, II and - III	37
	Relative CO <sub>2</sub> emission: BEV, PHEV, HEV relative to ICEV	38
3.4	Cost of vehicle ownership	39
	Socio-economic assumptions	39
	General vehicle assumptions	39
	EV battery cost assumptions	40
	Annual fuel/electricity costs and vehicle maintenance costs	41
3.5	Overview: Cases analyzed for individual vehicles	42
	Ownership cost: Reference assumptions	43
	Ownership cost: DOE (2010) Recovery Act Battery cost assumptions	44
	Relative cost of ownership: BEV, PHEV and HEV relative to ICEV	44
	Ownership cost: CO <sub>2</sub> emission impact	45
	Relative cost of ownership, including CO <sub>2</sub> Case I and II reduction	46
	Ownership costs: Impact of electricity and fuel prices	48
3.6	Conclusion on individual EVs	50
<b>4</b>	<b>EV and road transport sector scenarios</b>	<b>52</b>
4.1	EV scenario aims	52
	EV market projections and scenario analysis	52
	Market share assumptions	53
	Approach	53
4.2	Danish stock of Passenger Cars + LCVs.	54
4.3	Scenario overview	55
	PHEV & BEV substitute ICEV (marginal analysis)	55
	Externalities not included	56

4.4	PHEV Scenario: Energy and CO <sub>2</sub>	58
	PHEV scenario: Fleet development	58
	PHEV scenario: Energy substitution	58
	PHEV scenario: CO <sub>2</sub> emission	59
4.5	PHEV-scenario: Socio-economic costs (marginal analysis)	61
	PHEV Scenario: BatCost I	61
	PHEV Scenario: BatCost II	63
4.6	BEV Scenario: Energy and CO <sub>2</sub>	64
	BEV scenario: Fleet development	64
	BEV scenario: Energy substitution	64
	BEV scenario: CO <sub>2</sub> emission	65
4.7	BEV-scenario: Socio-economic costs (marginal)	66
	BEV Scenario: BatCost I	66
	BEV Scenario: BatCost II	68
4.8	Conclusion on EV scenarios	69
<b>5</b>	<b>EV and grid interaction</b>	<b>71</b>
5.1	EV technology development	71
5.2	Availability of EVs in V2G infrastructure	73
5.3	Intelligent charging and communication/data structures.	74
5.4	Integration of Wind Power and EV fleet Regulating Power	75
5.5	The EDISON project	77
5.6	Conclusion	78
<b>6</b>	<b>EVs and the Danish Distribution Grid</b>	<b>79</b>
6.1	About the Danish Distribution Grid	79
6.2	Results from modelling of EVs impact on distribution grid loading	80
6.3	Ancillary power system services' impact on the distribution grid	82
6.4	Peak load in low voltage grids	82
6.5	Power rating of EV charging	83
6.6	Voltage flicker	83
6.7	Asymmetric phase loading	84
6.8	Harmonic distortion	84
6.9	Conclusions	85
<b>7</b>	<b>EVs and their impact on transmission systems</b>	<b>87</b>
7.1	Background	87
7.2	Different charging strategies	87
7.3	Impact on demand for generation capacity	88
7.4	Security of supply - power adequacy	89
7.5	Demand for downward regulation of wind power generation	90
7.6	Supply of ancillary services	91
7.7	Transmission line capacity (>100 kV)	92
7.8	Conclusion	92
<b>8</b>	<b>EV modelling in Balmorel and Wilmar</b>	<b>94</b>
8.1	Modelling electric vehicles in Balmorel	94
8.2	Modelling electric vehicles in Wilmar	97
8.3	Conclusions	100
<b>9</b>	<b>Balmorel model results – EVs and power system investments</b>	<b>101</b>
9.1	Scope and preconditions	101
9.2	Results	103
	Effects on power system investments	103

Effects on electricity generation	105
CO <sub>2</sub> emissions	106
Costs	107
Sensitivity analysis	108
9.3 Conclusions	109
<b>10 Wilmar model results – EVs and the value of smart charging</b>	<b>110</b>
10.1 Scenarios	110
10.2 Results	112
Sources of benefits from smart EVs	113
Benefits of Vehicle-to-Grid	114
Market prices	115
CO <sub>2</sub> emissions	116
10.3 Conclusions	116
<b>11 Conclusions and Discussion</b>	<b>118</b>
Discussion	124
<b>12 Appendices</b>	<b>125</b>
12.1 ‘Snapshot’ of Electric Vehicle - related activities.	125
12.1 Models	130
Sivael	130
Assess	130
Balmorel	130
Wilmar	131
12.2 Input data for the analysis in Chapter 9	132
Power regions, district heating areas and time resolution	132
Electricity, district heating and transport demands	132
Vehicle data	133
Existing power systems	134
Technologies available for investment	135
Fuel prices and CO <sub>2</sub> prices	136
Wind potentials and targets	136
Hydro power generation	136

## List of figures

<i>Figure 1 Relative cost ownership. A: Battery cost data: BATCost I scenario. B: Relative cost ownership. Battery cost data: BATCost II scenario.</i>	16
<i>Figure 2 A: Assumed market share for plug-In hybrid electric vehicles (PHEV). B: Number of vehicles in the Danish fleet and age group composition in Scenario A2T* for plug-In hybrid electric vehicles (PHEV) for category Passenger cars + LCV&lt;3.5t. Source on market share development: EPRI Report 1015326 Environmental Assessment of Plug-In Hybrid Electric Vehicles. Volume 1: Medium PHEV scenario, July 2007.</i>	17
<i>Figure 3 Transport energy use in PHEV scenario. (The PHEV alternative fuel and electricity use expressed in numbers &gt; 0. Reference ICEV fuel substituted expressed in numbers &lt; 0.) [TWh/year]</i>	18
<i>Figure 4 CO<sub>2</sub>-emission in PHEV scenario assuming CO<sub>2</sub> Case I. [1000 ton CO<sub>2</sub>/year]</i>	19
<i>Figure 5 CO<sub>2</sub> emission in PHEV scenario assuming CO<sub>2</sub> Case III. [1000 ton CO<sub>2</sub>/year]</i>	20
<i>Figure 6 PHEV scenario: Socio-economic costs based on: Reference assumptions via BatCost I, Fuelcost I &amp; Elcost I. (PHEV scenario costs (alternative) are expressed in numbers &gt;0. ICEV reference costs are expressed in numbers &lt; 0.) [Mio.\$/year]</i>	21
<i>Figure 7 PHEV scenario socio-economic costs assuming: BatCost II, Fuelcost I &amp; Elcost I. [Mio.\$/year]</i>	21
<i>Figure 8 EU-27: Final energy and non-energy consumption by fuel and end-use sector, 2006</i>	27
<i>Figure 9 EU-27: Electricity generation in 2006: Share by source.</i>	28
<i>Figure 10 Assumptions on ICEV, HEV, PHEV and BEV specific energy consumption for vintage groups up to year 2030. [kWh/km] (gasoline/diesel or electricity). Reference: COWI 2007 [31]and EPRI 2007 [32]</i>	33
<i>Figure 11 Comparison of ICEV, HEV and PHEV assumptions on the specific fuel consumption (gasoline/diesel) for vintage groups to year 2030. [km/ liter fuel]</i>	33
<i>Figure 12 Assumptions on PHEV and BEV range per charge and size of battery pack for vintage groups to year 2030.</i>	34
<i>Figure 13 Plug-in Hybrid Electric Vehicles (PHEV): Percents of annual driving using electricity when battery capacity corresponds to x km / charge. Passenger cars + LCV &lt; 3.5t. Source: Estimated (Weibull) distribution for daily distance driven (in this Danish fleet segment) based on data from ref. [45], DTU Transport: 'Transport Vane Undersøgelse: 2006+2007'.</i>	35
<i>Figure 14 Assumptions on ICEV and HEV specific CO<sub>2</sub> emission. [g CO<sub>2</sub>/km]</i>	35
<i>Figure 15 A: Assumed development for the specific CO<sub>2</sub> emission related to (marginal and average) electricity consumption in Denmark until year 2030. [Source: DEA 2010, DEA 2011]. Figure 15 B: Vehicle lifetime average specific CO<sub>2</sub> emission: The average CO<sub>2</sub> emission per kWh electricity used by an EV, when emissions are averaged over the vehicle lifetime, 16 years forward. Based on 'A' assumptions. [kg CO<sub>2eq</sub>/MWh<sub>el</sub>]</i>	36
<i>Figure 16 Assumptions on PHEV and BEV life time average specific CO<sub>2</sub> emission in CO<sub>2</sub>Case I (DK-DEA 2010 reference. Marginal electricity consumption CO<sub>2</sub>-characteristics ), CO<sub>2</sub>Case II (DK-DEA 2011 reference. Average electricity consumption CO<sub>2</sub>-characteristics), and CO<sub>2</sub>Case III (Alternative. Average and</i>	

<i>linear descend to zero CO<sub>2</sub> emission in 2050) for the power system development. [16 years forward average: g CO<sub>2</sub>/km]</i>	37
<i>Figure 17 Comparison of CO<sub>2</sub> consequences for the alternative vehicles assuming CO<sub>2</sub>Case I and CO<sub>2</sub>Case III for the power system development.</i>	38
<i>Figure 18 Battery cost scenarios assumed for both PHEV and BEV vehicles.</i>	41
<i>Generally it has been assumed that the ‘end of life’ value of the batteries is zero. This has been assumed despite an after vehicle life value of EV batteries can be expected e.g. for stationary applications. Taking into account a discount rate and the lifetime assumptions for batteries, cf. Figure 19, the net present value of such second application will be a minor fraction of the battery net cost. Combining battery cost, battery lifetime and annual fuel and maintenance costs, cf. Figure 20 and Figure 21, the zero ‘end of life’ value assumption seems</i>	41
<i>Figure 22 Assumption made on the vehicle annual fuel/electricity costs and maintenance costs. Fuel and electricity prices are based on DEA forecasts, April 2010.</i>	42
<i>Figure 23 Socio-economic cost of ownership for the fuel based vehicles ICEV and HEV. [\$/year]</i>	43
<i>Figure 24 Socio-economic cost of ownership for the electricity based vehicles PHEV and BEV assuming the BatCost I scenario. [\$/year]</i>	43
<i>Figure 25 Socio-economic costs of ownership for the electricity based vehicles PHEV and BEV assuming the BatCost II scenario. [\$/year]</i>	44
<i>Figure 26 Relative cost ownership. A: Battery cost data: BATCost I scenario. B: Relative cost ownership. Battery cost data: BATCost II scenario.</i>	45
<i>Figure 27 Cost of CO<sub>2</sub> emission allowance. Source: Danish Energy Authority (DEA), April 2010.</i>	45
<i>Figure 28 Relative cost of vehicle ownership, including value of CO<sub>2</sub> reduction in cases CO<sub>2</sub>Case I and CO<sub>2</sub>Case III.</i>	46
<i>Figure 29 Energy price developments assumed for fuel (gasoline/diesel) and electricity.</i>	48
<i>Figure 30 Relative cost ownership. Battery cost data: BATCost I and BATCost II. Energy price data: (FuelCost II &amp; ElCost II) and (FuelCost III &amp; ElCost III).</i>	49
<i>Figure 31 Development assumed for the Danish stock of Passenger Cars + LCV &lt; 3.5t. Diagonal lines describe the accumulated number of new vehicles entering the fleet. Based on DTF Forecast 2007 [41].</i>	54
<i>Figure 32 End of life distribution for vehicles in the Danish fleet assumed for the scenario analysis. Covering Passenger Cars + LCV &lt; 3.5t. (Average lifetime: 17 years.). Source: ‘The EMMA model’, Risø DTU. [46]</i>	54
<i>Figure 33 A: Assumed market share for plug-In hybrid electric vehicles (PHEV). B: Number of vehicles in the Danish fleet and age group composition in Scenario A2T* for plug-In hybrid electric vehicles (PHEV) for category Passenger Cars+LCV&lt;3.5t. Source on market share development: EPRI Report 1015326 Environmental Assessment of Plug-In Hybrid Electric Vehicles. Volume 1: Medium PHEV scenario, July 2007.[42]</i>	58
<i>Figure 34 Transport energy use in PHEV scenario. (The PHEV alternative fuel and electricity use expressed in numbers &gt; 0. Reference ICEV fuel substituted expressed in numbers &lt; 0.) [TWh/year]</i>	58
<i>Figure 35 CO<sub>2</sub>-emission in PHEV scenario assuming CO<sub>2</sub> Case I. [1000 ton CO<sub>2</sub>/year]</i>	59
<i>Figure 36 CO<sub>2</sub> emission in PHEV scenario assuming CO<sub>2</sub> Case III. [1000 ton CO<sub>2</sub>/year]</i>	60



<i>Figure 37 PHEV scenario: Socio-economic costs based on: Reference assumptions via BatCost I, Fuelcost I &amp; Elcost I. (PHEV scenario costs (alternative) are expressed in numbers &gt;0. ICEV reference costs are expressed in numbers &lt; 0.) [Mio.\$/year]</i>	61
<i>Figure 38 PHEV scenario socio-economic costs assuming: Fuelcost II &amp; Elcost II (Linear increase to +20% in 2030) and BatCost I. [Mio.\$/year]</i>	62
<i>Figure 39 PHEV scenario socio-economic costs assuming: Fuelcost III &amp; Elcost III (Linear decrease to -20% in 2030) and BatCost I. [Mio.\$/year]</i>	62
<i>Figure 40 A: PHEV scenario socio-economic costs assuming: BatCost II, Fuelcost I &amp; Elcost I. [Mio.\$/year]</i>	63
<i>Figure 41 A: Assumed market share for battery electric vehicles (BEV) for category Passenger Cars+LCV&lt;3.5t. B: Number of vehicles in the Danish fleet and age group composition in Scenario A2T* for plug-In hybrid electric vehicles (BEV) in category Passenger Cars + LCV &lt;3.5t.</i>	64
<i>Figure 42 Transport energy use in BEV scenario. (The BEV alternative electricity use is expressed in numbers &gt; 0. Reference ICEV fuel substituted expressed in numbers &lt; 0.) [TWh/year]</i>	64
<i>Figure 43 CO<sub>2</sub> emission in BEV scenario assuming CO<sub>2</sub> Case I. [1000 ton CO<sub>2</sub>/year]</i>	65
<i>Figure 44 CO<sub>2</sub> emission in BEV scenario assuming CO<sub>2</sub> Case III. [1000 ton CO<sub>2</sub>/year]</i>	65
<i>Figure 45 BEV scenario socio-economic costs assuming: BatCost I, Fuelcost I &amp; Elcost I. Reference assumptions. (BEV scenario costs (alternative) are expressed in numbers &gt;0. ICEV reference costs are expressed in numbers &lt; 0.) [Mio.\$/year]</i>	66
<i>Figure 46 BEV scenario socio-economic costs assuming: BatCost I &amp; Fuelcost I &amp; Elcost I (Linear increase to +20% in 2030) and BatCost I. [Mio.\$/year]</i>	67
<i>Figure 47 BEV scenario socio-economic costs assuming: BatCost I &amp; Fuelcost III &amp; Elcost III (Linear decrease to -20% in 2030) and BatCost I. [Mio.\$/year]</i>	67
<i>Figure 48 A: BEV scenario socio-economic costs assuming: BatCost II, Fuelcost I &amp; Elcost I. [Mio.\$/year]</i>	68
<i>Figure 49 The ECOMove EV platform and vehicle. (Source: ECOMove, 2011)</i>	72
<i>Figure 50 Availability of the Danish personal vehicle fleet. Figure (a) assumes Lyngby's pattern is representative of Denmark. It underestimates the actual minimum availability during regular day. Figure(b) assumes Copenhagen's (Amagerbrogade) pattern is representative of Denmark. It overestimates the actual minimum availability. [5.2]</i>	74
<i>Figure 51 The number of hours (in percent), where EVs are able to cover the deviation between the predicted and the produced power in Western DK. The "Set" relates to the mix of EV's and PHEV's. Set 1 is primarily PHEV's. Set 4 is pure EV's.</i>	76
<i>Figure 52 Electricity load curves by sector</i>	79
<i>Figure 53. Share of houses that can have an EV as a function of time of charging</i>	80
<i>Figure 54 Loading results of not controlled versus controlled charging of EVs in low voltage grids in areas not expected to get heat pumps.</i>	80
<i>Figure 55 Possible scenario for the future power system</i>	81
<i>Figure 56 Illustration of asymmetric voltage</i>	84
<i>Figure 57. Illustration of harmonic distortion of current</i>	85
<i>Figure 58 Duration curve, power demand less wind power generation. The three charging strategies are shown.</i>	88

<i>Figure 59 Probabilistic calculation of loss of load for a reference situation without EVs and three different EV charging strategies.</i>	89
<i>Figure 60 Hours when downward regulation of wind power generation is required, calculated for different EV charging modes and for a reference situation without EVs. The figure shows the number of hours and the corresponding demand for downward regulation of wind power generation.</i>	90
<i>Figure 61 Sketch of the Balmorel model including transport</i>	94
<i>Figure 62 The transport add-on in Balmorel</i>	95
<i>Figure 63 Propulsion system configuration of (series) electric drive vehicles</i>	96
<i>Figure 64 Illustration of the rolling planning and the decision structure in each planning period.</i>	98
<i>Figure 65 Simplified example pattern of electric vehicles arriving at the power grid at 19.00h. The thicker the line, the greater the share of vehicles which return to the network at that time.</i>	99
<i>Figure 66 a) Development in plug-in hybrid electric vehicles (PHEV) new vehicle shares in the Medium scenario in [91] and illustration of the assumed relation between battery electric vehicle (BEV) and PHEV new vehicle shares based on the Blue Map Scenario in [92]. b) Assumed gradual penetration of PHEVs and BEVs in the vehicle fleet (ICE: Internal Combustion Engine vehicles).</i>	101
<i>Figure 67. Investments in power production capacities in the Base and EV scenario, representing accumulated investments over each five year period. E.g. investments in 2020 represent accumulated investments from 2016 through 2020. WI: Wind power; ST-COAL: Steam turbine, extraction, coal; OC-GT: Open cycle gas turbine; NUC: Nuclear power.</i>	104
<i>Figure 68. Changes in annual electricity generation due to implementation of electric vehicles. Due to import/export, possible changes in electricity consumption for heat pumps/electric boilers, and in the use of pumped hydro electricity storage, generated power increases in each year will not necessarily correspond to the electricity demand for electric vehicles.</i>	106
<i>Figure 69 a). Danish CO<sub>2</sub> emissions for the simulated power, heat and transport system in the Base and EV scenario. b) Danish CO<sub>2</sub> emissions in 2025 and 2030, divided on sources for the two scenarios.</i>	107
<i>Figure 70 a). Total costs for the simulated power, heat and transport system for the Northern European countries in the Base and EV scenario. b) Total costs in 2020 and 2025, divided on sources.</i>	107
<i>Figure 71. The division of the benefit from smart EVs over dumb EVs between different components. The total benefit was 227 €/vehicle/year.</i>	114
<i>Figure 72 Market benefits and prices of smart and dumb EVs. Market price of smart and dumb EVs is the sum of hourly market prices for charging the EVs in these scenarios. This includes revenue from discharging in the smart EVs scenario. Market benefit of smart EVs is the difference between the dumb and smart scenarios.[€/vehicle/year]</i>	115
<i>Figure 73 Electricity generation in the present power systems of five Northern European countries distributed on sources. The distribution is generated by the model for 2010 for the Base scenario when not allowing investments in new capacities.</i>	134

## List of tables

<i>Table 1. Change in Danish CO<sub>2</sub> emissions reductions due to implementation of EVs depending on fuel and CO<sub>2</sub> price conditions .....</i>	<i>108</i>
<i>Table 2. Capacity of New Power Plants in the Different Balmorel Scenarios.....</i>	<i>112</i>
<i>Table 3. Cost of scenarios compared to the base scenario, in which V2G was allowed.....</i>	<i>114</i>
<i>Table 4 Expectations to EV market development for Light Passenger Vehicles.....</i>	<i>125</i>
<i>Table 5. Electricity demands .....</i>	<i>132</i>
<i>Table 6. District heating demands.....</i>	<i>133</i>
<i>Table 7. Transport demands.....</i>	<i>133</i>
<i>Table 8. Annual driving for each vehicle type.....</i>	<i>133</i>
<i>Table 9. Vehicle technology data. ....</i>	<i>134</i>
<i>Table 10. Technologies available for investment in the optimisation. ....</i>	<i>135</i>
<i>Table 11. Fuel and CO<sub>2</sub> quota price projections for 2010-2030 (€/GJ) [13] .....</i>	<i>136</i>
<i>Table 12. Wind targets for 2030 and assumed onshore wind potentials.....</i>	<i>136</i>
<i>Table 13. Hydro power generation assumed.....</i>	<i>137</i>

# Preface

## Acknowledgement

This report is a result of the project: *Electricity for Road Transport, Flexible Power Systems and Wind Power*.

The project is funded by EUDP/EFP07-II (Danish Energy Technology Development and Demonstration Program). Identifier: EUDP (DENP) journal nr. 33033 – 0218 at the Danish Energy Agency (Denmark). The project has furthermore gained support from Risø DTU and the project partner organizations Danish Energy Association and Energinet.dk. Project period: Start March 2008 to ultimo September 2011. Apart from this final report, results from the project comprise international articles, conference papers and a workshop. Reference to these items can be found at the project homepage <http://www.g2v2g.dk> . Responsibility for the content of this document lies with the authors. It does not represent opinions of the funding organizations.

## Project partners:

- Systems Analysis Division, Risø National Laboratory for Sustainable Energy. Technical University of Denmark (DTU)
- Intelligent Energy Systems Programme, Risø National Laboratory for Sustainable Energy. Technical University of Denmark (DTU)
- Centre for Electric Technology, Department of Electrical Engineering. Technical University of Denmark (DTU)
- RAM-løse edb
- Energinet.dk, Planer & Scenarier
- Energinet.dk, Analyse og metoder
- Danish Energy Association

## Project group:

The project has been carried out in a project group comprising:

### *Project leader*

Senior Scientist Lars Henrik Nielsen, Systems Analysis Division, Risø National Laboratory for Sustainable Energy, Technical University of Denmark, P.O. Box 49, DK-4000 Roskilde, Denmark, Tel. (+45) 4677 5110, e-mail: [lan@risoe.dtu.dk](mailto:lan@risoe.dtu.dk)

### *Project participants*

Dr. Techn. Hans Ravn, RAM-løse edb, tlf: (+45) 6077 0255, e-mail: [HansRavn@aeblevangen.dk](mailto:HansRavn@aeblevangen.dk)

Professor Peter Meibom, Intelligent Energy Systems Programme (IES), Risø National Laboratory for Sustainable Energy, Technical University of Denmark, tlf: (+45) 4677 5119, fax: (+45) 4677 5199, e-mail: [peme@risoe.dtu.dk](mailto:peme@risoe.dtu.dk)

PhD candidate, Nina Juul, Systems Analysis Division, Risø National Laboratory for Sustainable Energy, Technical University of Denmark, tlf: (+45) 4677 5179, fax: (+45) 4677 5199, e-mail: njua@risoe.dtu.dk

PhD candidate, MSc Eng. Karsten Hedegaard, Systems Analysis Division, Risø National Laboratory for Sustainable Energy, Technical University of Denmark, tlf: +45 4677 5158, fax:(+45) 4677 5199, khed@dtu.dk

Senior Scientist Helge V. Larsen, Systems Analysis Division, Risø National Laboratory for Sustainable Energy, Technical University of Denmark, tlf: (+45) 4677 5114, fax: (+45) 4677 5199, e-mail: [hela@risoe.dtu.dk](mailto:hela@risoe.dtu.dk)

Senior Scientist Kaj Jørgensen, Systems Analysis Division, Risø National Laboratory for Sustainable Energy, Technical University of Denmark tlf: (+45) 4677 5104, fax: (+45) 4677 5199, e-mail: kaj.joergensen@risoe.dk  
(Until 2009).

Associate Professor Esben Larsen, Center for Elteknologi, Institut for Elektroteknologi. Technical University of Denmark – DTU, tlf: (+45) 4525 3512, fax: (+45) 4588 6111, e-mail: ela@elektro.dtu.dk

Associate Professor Jørgen Horstmann, Center for Elteknologi, Institut for Elektroteknologi. Technical University of Denmark tlf: (+45) 4542 2438 , fax: (+45) 4588 6111, e-mail: [jph@elektro.dtu.dk](mailto:jph@elektro.dtu.dk). (Until 2009).

Seniorudviklingsingeniør Per Nørgaard, Intelligent Energy Systems Programme (IES), Risø National Laboratory for Sustainable Energy, Technical University of Denmark, tlf: (+45) 4677 5068, fax: (+45) 4677 5083, e-mail: pern@risoe.dtu.dk

Civilingeniør Anders Bavnhøj Hansen, Strategic Planning, Energinet.dk, tlf.: +45 76 22 45 24, fax: +45 76 24 51 80, e-mail: abh@energinet.dk

Civilingeniør Jens Pedersen, Analyses and Methods, Energinet.dk, tlf.: +45 76 22 44 24, fax: +45 76 24 51 80, e-mail: jpe@energinet.dk

Systemplanlægger Nicolai Anders Kipp, Analyses and Methods, Energinet.dk, tlf.:+45 7622 4534, Mobil: +45 2333 8926, fax:+45 7624 5180, e-mail: nki@energinet.dk

Civilingeniør Hans Abildgaard, Analyses and Methods, Energinet.dk, tlf.: +45 76 22 45 38, fax: +45 76 24 51 80, e-mail: hab@energinet.dk

Consultant Civilingeniør Anders Holm Foosnæs, Danish Energy Association, tlf.: (+45) 3530 0784, Mobil (+45) 20 907 784, e-mail: afo@danskenergi.dk

#### **Authors:**

Authors for Chapters of the present report are given below except where the project group as a whole, are authors:

Chapter 3: The electric vehicle (EV) status and expected development: Lars Henrik Nielsen, Risø DTU

Chapter 4: EV and road transport sector scenarios: Lars Henrik Nielsen, Risø DTU

Chapter 5: EV and grid interaction: Esben Larsen, CET DTU; Per Nørgaard, IES Risø DTU

Chapter6: EVs and the Danish Distribution Grid: Anders Foosnæs, Danish Energy Association

Chapter 7: EVs and their impact on transmission systems: Anders Bavnhøj Hansen, EnergiNet.dk

Chapter 8: EV modelling in Balmorel and Wilmar: Juha Kiviluoma, VTT, Nina Juul and Peter Meibom, Risø DTU

Chapter 9: Balmorel model results – EVs and power system investments: Karsten Hedegaard, Nina Juul and Peter Meibom, Risø DTU; Hans Ravn, RAM-løse edb

Chapter10: Wilmar model results – EVs and the value of smart charging. Juha Kiviluoma, VTT and Peter Meibom, Risø DTU

**Contact/advisory group:**

- Michael Rask, ENS, e-mail: mir@ens.dk; tlf.: (+45) 3392 7530
- Benny Christensen, e-mail: bemc@tiscali.dk, bemctim@gmail.com; tlf.: (+45) 9733 3280
- Aksel Hauge Pedersen, DONG Group R&D, e-mail: akhpe@dongenergy.dk; tlf.: (+45) 9955 2127 / (Until 2009)
- Jane Pedersen, DONG Group R&D, e-mail: xjanp@dongenergy.dk; tlf.: (+45) 9955 9173 / (Until 2009)
- Torben V. Holm, DONG Energy, e-mail: tovho@dongenergy.dk; tlf.: (+45) 9955 2048

**Contact person:**

Lars Henrik Nielsen  
Risø National Laboratory for Sustainable Energy,  
Technical University of Denmark  
Systems Analysis Division  
P.O. Box 49  
DK-4000 Roskilde  
Denmark  
Tel. (+45) 4677 5110  
E-mail: lani@risoe.dtu.dk

**Keywords:**

Electric Vehicles; Plug-In Hybrid; Hybrid Electric Vehicles; Battery Electric Vehicles; Internal Combustion Engine Vehicle; Transport sector; Power sector; CO<sub>2</sub> emission; CO<sub>2</sub> emission reduction; Socio-economy, Modelling, Simulation; Power system; Power System Optimization, Energy Supply; Energy Security; Scenario Analysis; Combined Heat and Power; Combined Heat Power and Transport; Wind Power; Power Markets; Electricity Grid, Power Transmission Grid, Power Distribution Grid, Ancillary Services; Power System Investments; System Operation Costs.

# 1 Executive summary

Presently the EU road transport sector relies to almost 100% on the fossil fuels gasoline and diesel. Vulnerability to potential fuel supply shortages, rising fuel prices and difficulties in meeting CO<sub>2</sub> emission reduction requirements constitute heavy challenges for the transport sector.

Integration of electric vehicles (EVs) in the transport sector may in the future significantly reduce the emission of pollutants and improve air quality in local and urban areas. Furthermore, through EVs developments in the power supply sector may have direct implications for the road transport emissions. Options in the power supply sector, as to reduce CO<sub>2</sub>-emissions in particular, become options for the transportation sector as well.

Strengthening the transition towards renewables and non-CO<sub>2</sub> emitting energy technology for power generation may in the future bring, both diversity in energy resources for power generation and very low GHG emission, ultimately leading to CO<sub>2</sub> neutral power generation and consequently CO<sub>2</sub> neutral electricity based road transport.

The potentially very large flexibility in electricity demands from electricity based road transport may facilitate a transition towards the future non-fossil and CO<sub>2</sub>-neutral power sector. The present project aims to illustrate and analyze some of these options, focusing on the case of Denmark mainly. The analysis aims to identify challenges for the successful integration of EV's and to quantify potential consequences for the Danish transport- and power sectors, being viewed as integral parts of, and interacting with, the northern European power system.

## 1.1 Scenario analyses

The following summing up of results from the analyses will focus mainly on the longer term consequences, - year 2030. The system analysed is in year 2030 characterised by

- *a transport sector*  
where the use of electric vehicles (EVs) is *assumed* to have developed to make up well 50 % of the Danish and European road transport segment:  
Passenger cars + light commercial vehicles (LCV) of weight < 3.5ton,  
and
- *a power sector*  
where *interaction* with electricity based segments of the transport sector (via evolved EV fleets) strongly may have impacted its development.

Generally the scenario analyses look at *differences* emerging when the assumed 'business as usual' scenario, or reference development scenario, is compared with set up alternative scenarios.

Analyses related to such system development towards year 2030 have been carried out at different levels, and different aspects have been in focus. The analyses concern:

### **Transport sector aspects**

- Electric vehicle (EV) and conventional vehicle (ICEV) developments
- Potential EV fleet developments

### **Power sector and grid aspects**

- Vehicle - grid connection and interaction issues
- Distribution grid – EV fleet interaction

- Transmission grid – EV fleet interaction

#### **Overall transport and power system aspects**

- EV fleet and overall power system development / investments and configuration
- EV fleet and overall power system interaction and operation

Conclusions drawn forward from the chain of analyses carried out will mainly address consequences for the energy consumption, and energy substitution (in type and from fossil towards renewable resources), and the CO<sub>2</sub> emission consequences. Furthermore, economic consequences for society at large are addressed. The main question asked is how the set up scenarios perform relative to overall (political) aims related to the security of energy supplies, energy economy, environment and climate.

## **1.2 Transport sector aspects**

### **Electric Vehicles substituting conventional vehicles in road transport.**

As basis for setting up scenarios (chapter 4) assumptions are made on the development of the reference vehicle (ICEV) and the alternative electricity based vehicles (EVs) up to 2030 for the fleet segment in focus (chapter 3). Assumptions concern the vehicle specific energy consumption, investment costs, the vehicle life-time, and costs for operation and maintenance.

Costs of ownership for the BEV, PHEV, HEV and ICEV type of vehicles are calculated seen from a socio-economic point of view, and thus based on socio-economic assumptions. The presented calculations in chapters 3 and 4 are *marginal* in the sense that use of the alternative vehicles does not influence the general assumptions made e.g. on power system developments. And the analysis is *limited* in the sense that only few aspects are taken into account when calculating the vehicle ownership costs seen from the perspective of society at large. Only vehicle investments, maintenance costs and cost of operation are included in the present analysis. *Infrastructure costs are thus not included, and so-called externalities are not included* (in contrast to some subsequent chapters).

#### *Relative cost of ownership: BEV, PHEV and HEV relative to ICEV*

Four types of vehicles are considered. When referring to these the following abbreviations are used:

- BEV: Battery Electric Vehicle (All-electric)
- PHEV: Plug-in Hybrid Electric Vehicle (Electric and ICE extends range)
- HEV: Hybrid Electric Vehicle (Fuel based only)
- ICEV: Internal Combustion Engine Vehicle (Fuel based only)

For a given vintage of vehicles the *relative cost of ownership* is defined for the BEV, PHEV and HEV as the cost of ownership relative to (or divided by) the cost of ownership for the conventional (defined reference) ICEV of the same vintage.

#### *EV battery cost assumptions*

EV battery costs, the specific energy and capacity of batteries per unit of weight, and the battery lifetime are main factors determining ownership costs of EVs. Two battery cost scenarios are assumed. These EV-battery cost scenarios will be mnemotechnically named:



- **BatCost I :** EV battery cost development scenario based on ref.: COWI (2007) [31] & IEA (2009) [43]
- **BatCost II:** EV battery cost development scenario based on ref.[35]: DOE, The Recovery Act: Transforming America’s Transportation Sector, Batteries and Electric Vehicles, July 14, 2010.

In the ‘*conservative scenario*’ BatCost I the relative costs of ownership for the electricity based vehicles, PHEV and BEV, are considerable higher than the conventional ICEV until late in the period, as seen from Figure 1A. The HEV is slightly cheaper than the ICEV falling to about 10% below the ICEV in 2030.

By the end of the period, year 2030, the BEV and in particular the PHEV costs are expected to be reduced considerable. By then the BEV is break-even with the ICEV. And the PHEV has ownership costs below the ICEV and on a level with the HEV.

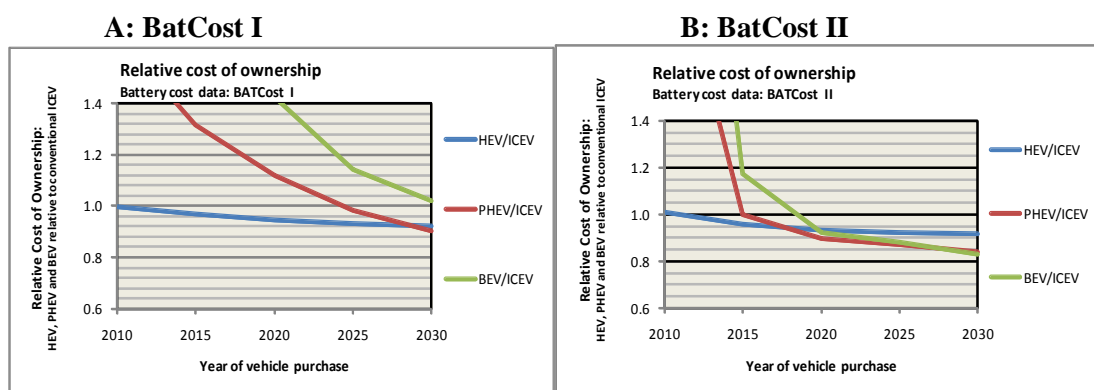

Figure 1 Relative cost ownership. **A:** Battery cost data: BATCost I scenario. **B:** Relative cost ownership. Battery cost data: BATCost II scenario.

Figure 1B illustrates the fast reduction in EV ownership costs based on assumptions from the more ‘*optimistic scenario*’ BatCost II. Scenario BatCost II reflects an assumption of a relatively fast battery cost reduction and improved battery life. Year 2015 the PHEV is expected to be break-even with the ICEV of vintage 2015. And from about 2020 and beyond the PHEV and BEV have vehicle lifetime costs below the HEV of same vintage. The BEVs become attractive getting annual socio-economic costs of ownership about 10%-17% below the ICEV from 2020-2030 in the BatCost II scenario.

The following is a summary of the ‘chapter 3’ conclusions:

#### Energy:

- Electricity substitutes gasoline/diesel via the EV. EV drive trains have potential for being very energy efficient.
- Via EVs segments of the transport sector can diversify its energy resource base and reduce dependency on oil based fuels.
- 3000 kWh electricity may sustain about 20.000 km average vehicle EV driving. About 10000 kWh of gasoline/diesel is required via the corresponding conventional ICEV.

#### CO<sub>2</sub> emission:

- EV CO<sub>2</sub> emission relates to the power supply system charging the vehicles. The CO<sub>2</sub> footprint of the individual EV changes in accordance with the power supply.

- According to the Danish ‘reference’ development for the *marginal* power supply EVs bring insignificant CO<sub>2</sub> reduction (due to coal dominated marginal power production).  
However, assuming *average* power supply characteristics, and *linear descend to zero CO<sub>2</sub> emission in 2050* for the power supply, substantial CO<sub>2</sub> reduction is achieved via EVs substituting ICEVs. Ultimately EVs may provide zero CO<sub>2</sub> emission road transport.
- The individual ICEV of today may emit about 2-3 ton CO<sub>2</sub> /year. This equals maximal achievable EV CO<sub>2</sub> reduction in ‘average’ per vehicle.

**Economy:**

- Cost and lifetime of EV batteries much determine the EV economy. This is based on the socio-economic cost of ownership.
- In a ‘*conservative scenario*’ (COWI 2007) on battery cost development PHEVs may get break-even with the ICEV beyond year 2020.  
In an ‘*optimistic scenario*’ (USDOE 2010) on battery cost development PHEVs may get break-even with the ICEV year 2015.
- CO<sub>2</sub> emission costs of emitting 2-3 ton CO<sub>2</sub> per year are small relative to the overall costs of vehicle ownership. Such costs are not likely to constitute an incentive for the choice of vehicle at purchase.
- Externalities and infrastructure costs are not included in this analysis. Most of the externalities NOT taken into account tend to act in favor of the EV alternatives.

**EV fleet development substituting conventional ICEV road transport.**

The EPRI 2007 assumptions on the PHEV market development [91] are in the present analyses used as basis for setting up EV scenarios corresponding to the Danish case (chapter 4). Relative market shares for the BEV and PHEV vehicles are based on the IEA Blue Map scenario from 2009 [92].

The EPRI Medium PHEV Scenario is replicated in Figure 2A below. Starting low year 2011, the market share for PHEVs is assumed to grow fast during the period 2015-2025 and reach a market share close to 50% in 2025. As consequence almost 40% of the vehicles on the road year 2030 in this fleet segment are PHEVs.

Figure 2B shows the corresponding number of alternative PHEV vehicles on Danish roads following the EPRI scenario. The number of PHEVs reaches about 1.110.000 PHEV vehicles year 2030 in this scenario. Colours are used to distinguish vehicle vintage groups in Figure 2B.

**A: PHEV market share**

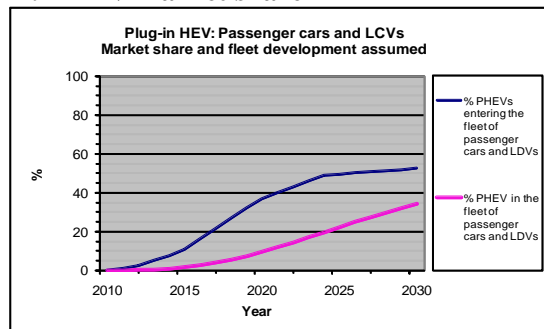

**B: PHEV fleet size**

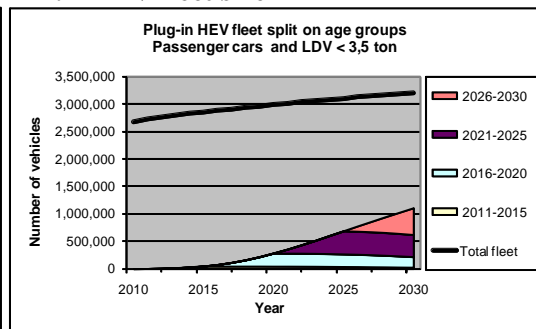

Figure 2 A: Assumed market share for plug-In hybrid electric vehicles (PHEV). B: Number of vehicles in the Danish fleet and age group composition in Scenario A2T\* for plug-In hybrid electric vehicles (PHEV) for category Passenger cars + LCV<3.5t. Source on market share

development: EPRI Report 1015326 Environmental Assessment of Plug-In Hybrid Electric Vehicles. Volume 1: Medium PHEV scenario, July 2007.

### PHEV Scenario: Energy substitution

Fuel (gasoline and diesel) substituted in the PHEV scenario in year 2030 equals about 9.0 TWh<sub>fuel</sub> /year (Figure 3). ICEVs substituted in 2030 reduce fuel consumption of about 11 TWh<sub>fuel</sub> and the alternative PHEVs are expected to consume about 2 TWh<sub>oil</sub> in year 2030.

The corresponding increase in electricity consumption year 2030 for operating the PHEV fleet amounts to 2.5 TWh<sub>electricity</sub>.

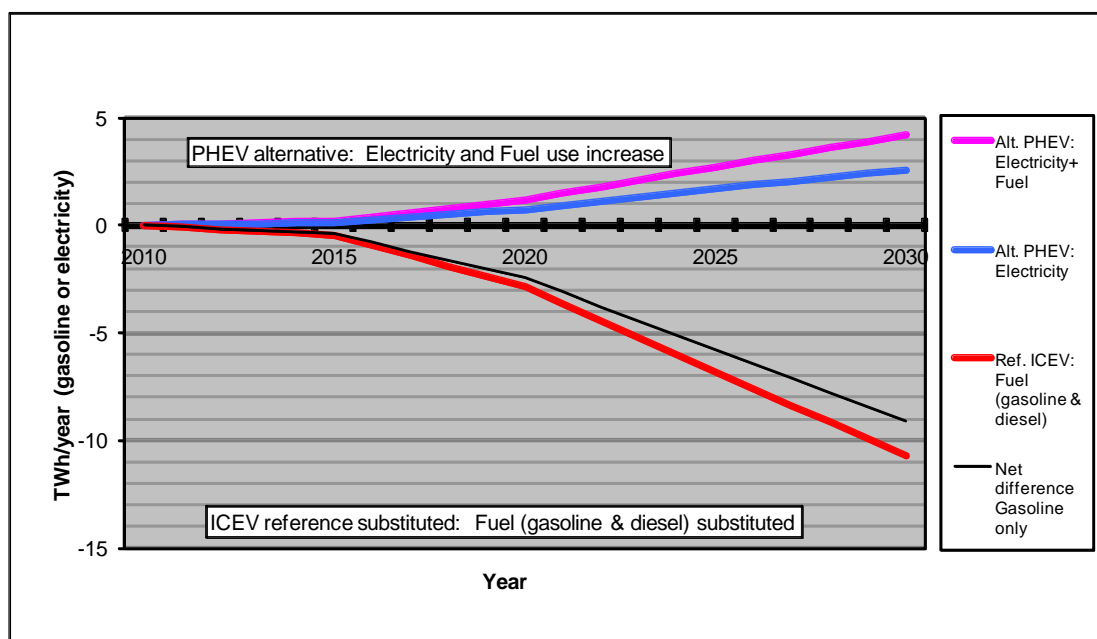

Figure 3 Transport energy use in PHEV scenario. (The PHEV alternative fuel and electricity use expressed in numbers > 0. Reference ICEV fuel substituted expressed in numbers < 0.) [TWh/year]

The numbers reflect a substantial substitution of oil based fuels at the expense of a rather moderate increase in electricity consumption. One kWh of electricity used by PHEVs substitutes about 3-4 kWh of fuel otherwise used by ICEVs year 2030, according to the PHEV scenario fleet composition year 2030.

### PHEV Scenario: CO<sub>2</sub> emission reduction

The analysis is split into two cases for the CO<sub>2</sub> emission related to electricity consumed in the Danish system. These are termed:

- **CO<sub>2</sub>Case I:** The *marginal* specific CO<sub>2</sub> emission per kWh electricity is almost constant over time. The power system develops according to forecast from The Danish Energy Authority (DEA, April 2010) [32]
- **CO<sub>2</sub>Case III:** The *average* specific CO<sub>2</sub> emission per kWh develops from characteristics of today's power system assuming a gradual linear phasing out to zero of all fossil fuels used in the system year 2050.

More details on these assumptions are described paragraph 3.3.

### PHEV scenario: CO<sub>2</sub>CaseI emission

Assuming CO<sub>2</sub> Case I, which implies the *marginal* and almost constant specific CO<sub>2</sub> emission per kWh electricity during the period, only minor CO<sub>2</sub> reductions are achieved. Substituting ICEVs with PHEVs in the Danish system following the PHEV scenario, only about 0.2 million ton CO<sub>2</sub>/year reduced emission is achieved in 2030 (Figure 4).

#### CO<sub>2</sub>CaseI: Marginal reference emission

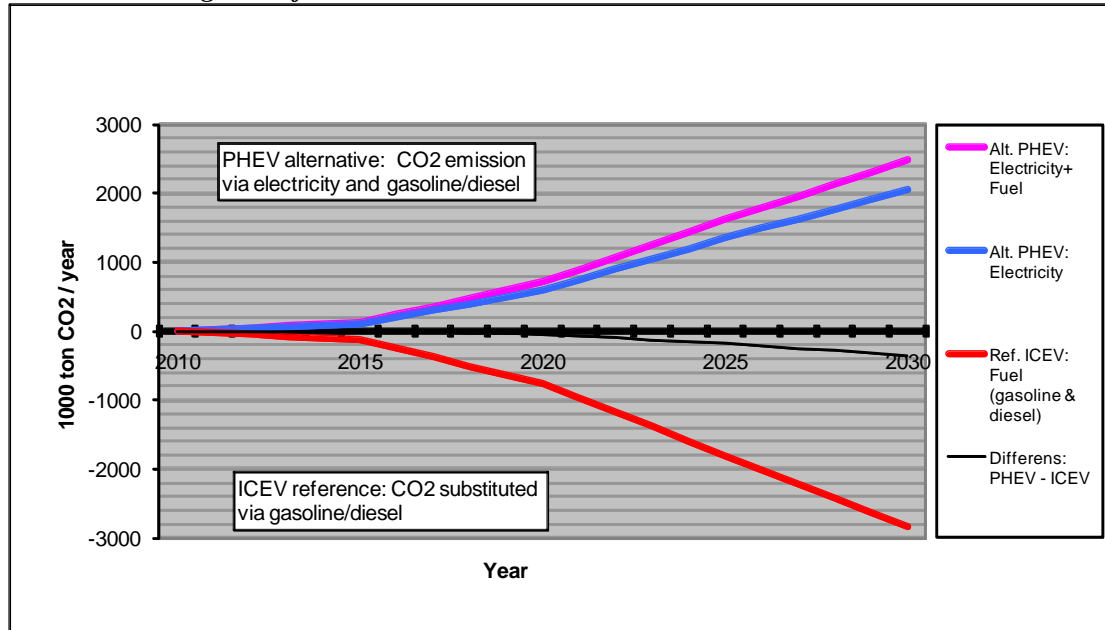

Figure 4 CO<sub>2</sub>-emission in PHEV scenario assuming CO<sub>2</sub> Case I. [1000 ton CO<sub>2</sub>/year]

The CO<sub>2</sub> characteristics for the *marginal* power production in this Danish reference system, being inherited by the PHEVs, will maintain emissions at about the same level as for the reference ICEVs.

#### CO<sub>2</sub>Case III: Descending average emission

Assuming CO<sub>2</sub> Case III, which assumes *average* power supply CO<sub>2</sub> characteristics, and which furthermore assumes a *linear descent to zero* CO<sub>2</sub>-emissions by 2050, the CO<sub>2</sub> reductions are pronounced. The PHEV scenario achieves an emission reduction of about 1.8 million ton CO<sub>2</sub>/year in 2030 (Figure 5). And as the power system develops towards lower emissions the existing PHEV fleet follows.

### CO<sub>2</sub> Case III: Descending average emission

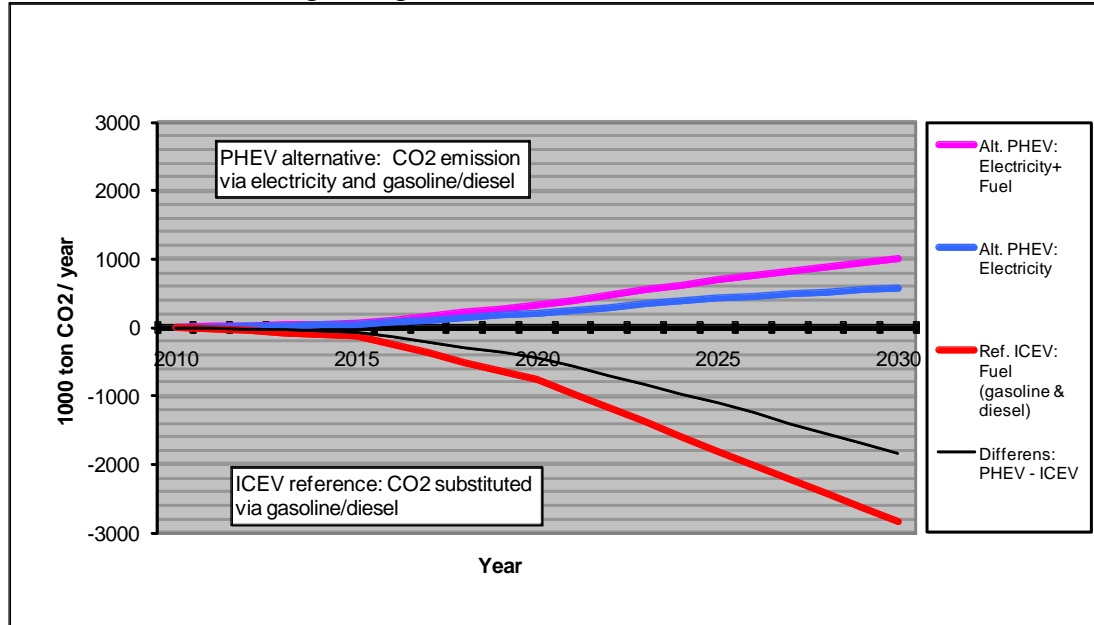

Figure 5 CO<sub>2</sub> emission in PHEV scenario assuming CO<sub>2</sub> Case III. [1000 ton CO<sub>2</sub>/year]

### PHEV-scenario: Socio-economic costs (marginal analysis)

The presented socio-economic costs are marginal costs in the sense that the transport scenario only 'marginally' interacts with the overall energy system. Thus the transport scenarios do not influence electricity prices and fuel prices. This evidently is a very crude assumption. In later chapters that include modelling of transport segments interacting with the overall power this limitation is not present.

#### PHEV Scenario and assuming 'conservative' BatCost I development:

Figure 6 shows the overall socio-economic costs for the PHEV scenario alternative broken down into the components:

- Alternative development:  
PHEV total annual costs (i.e. annual cost of propellants, maintenance and investment).  
PHEV cost for propellants (Electricity and fuel)
- Corresponding reference development:  
ICEV total annual costs (i.e. annual cost of propellants, maintenance and investment).  
ICEV costs for fuel
- Difference:  
Overall scenario socio-economic costs (Difference = Alternative – Reference) for each year in the period 2010-2030.

Energy price assumptions (termed Fuelcost I & Elcost I) adopted as basis for results presented in chapter 4, are the so-called 'Baseline forecast' from the Danish Energy Authority (DEA) April 2010. [32]

It is seen from Figure 6 that costs are almost equal for the alternative PHEV scenario and the corresponding reference (ICEV) scenario development. Details show that annual deficits rise to about 100 Mio.\$/year in year 2020, and descend from then on. Annual gains emerge from about year 2027 reaching a gain of about 50 Mio.\$/year in year 2030.

### BatCost I & Fuelcost I & Elcost I

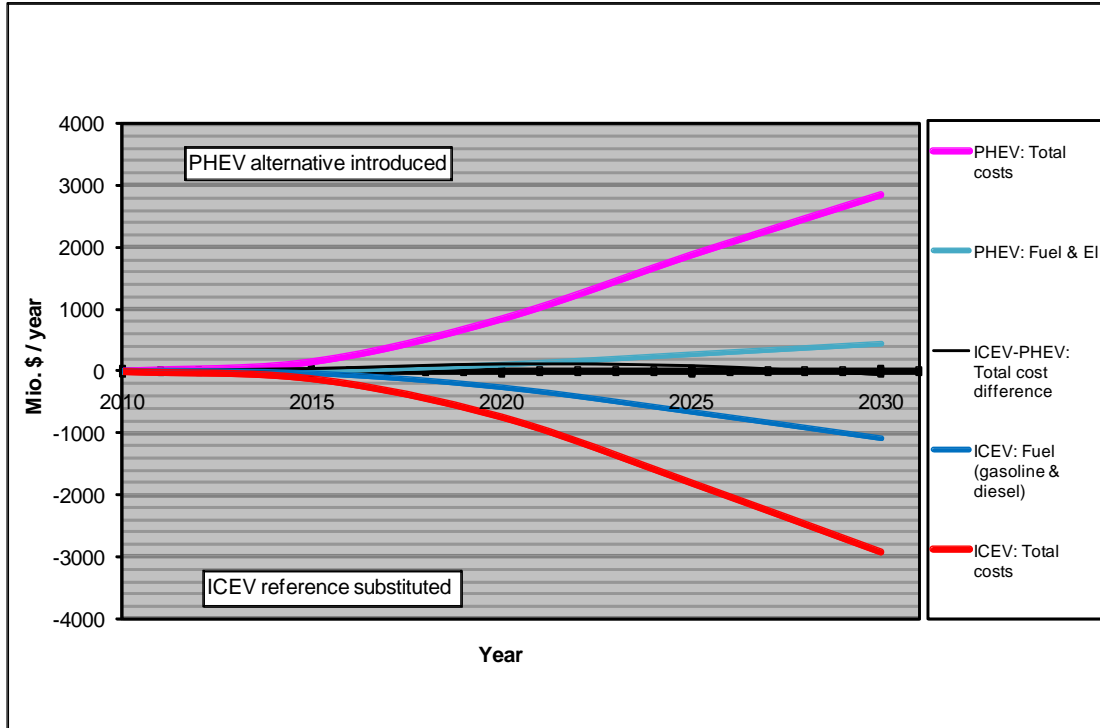

Figure 6 PHEV scenario: Socio-economic costs based on: Reference assumptions via **BatCost I**, Fuelcost I & Elcost I. (PHEV scenario costs (alternative) are expressed in numbers >0. ICEV reference costs are expressed in numbers < 0.) [Mio.\$/year]

PHEV Scenario and assuming 'optimistic' **BatCost II** development:

### BatCost II & Fuelcost I & Elcost I

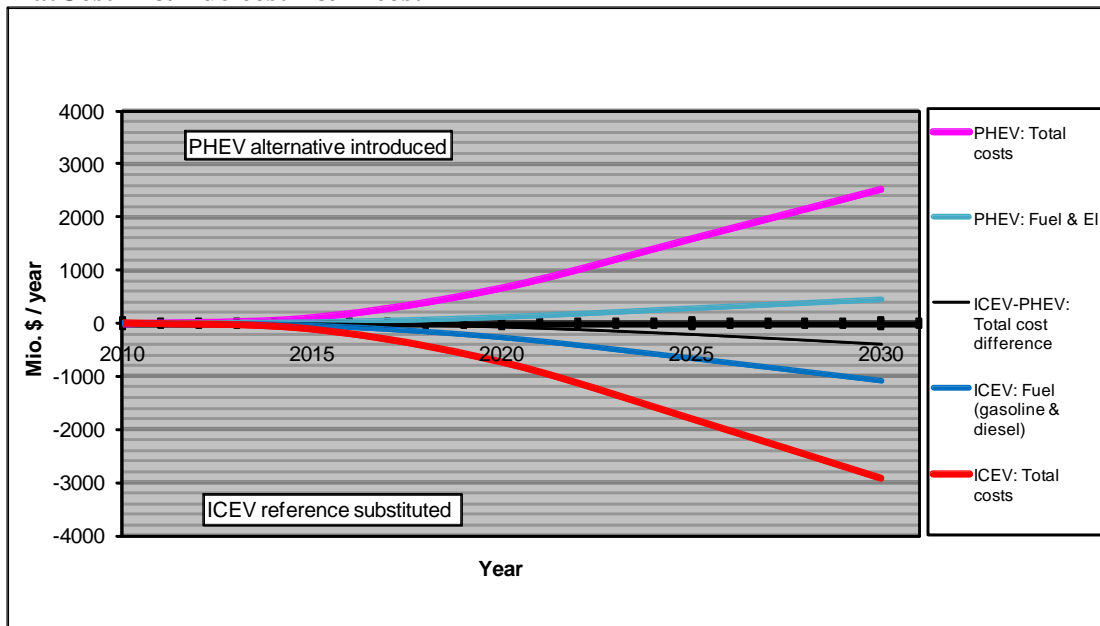

Figure 7 PHEV scenario socio-economic costs assuming: **BatCost II**, Fuelcost I & Elcost I. [Mio.\$/year]

Assuming battery costs and lifetime developing according to BatCost II assumptions (Ref.: US DOE Recovery Act, 2010 [35]) the PHEV vehicle scenario shows socio-economic gains already from year 2015.

In year 2030 the PHEV scenario shows an annual surplus of about 400 Mio.\$/year (Figure 7).

Summary of chapter 4 conclusions:

#### **Energy:**

EVs can diversify the energy resource base in the transport sector and reduce the dependency on oil based fuels.

- PHEV scenario year 2030: Fleet size about 1.1 million vehicles.  
Fuel (gasoline/diesel) substituted (net): About 9.0 TWh<sub>fuel</sub>/year.  
PHEV fleet electricity consumption: About 2.5 TWh electricity.
- BEV scenario year 2030: Fleet size about 0.55 million vehicles.  
Fuel (gasoline/diesel) substituted: About 5.4 TWh<sub>fuel</sub>/year.  
BEV fleet electricity consumption: About 1.7 TWh electricity.

The numbers reflect the relatively high energy efficiency of EV drive trains.

#### **CO<sub>2</sub> emission and the environment:**

- The CO<sub>2</sub> emission depends on the power supply system charging the EV fleets.  
PHEV scenario year 2030: Fleet size about 1.1 million vehicles.  
About 1.8 million ton CO<sub>2</sub> reduction.
- BEV scenario year 2030: Fleet size about 0.55 million vehicles.  
About 0.9 million ton CO<sub>2</sub> reduction.

This based on the assumption of a *linear descend to zero CO<sub>2</sub> emission in 2050* for Danish power supply (Danish political aim), and based on an assumption of *average CO<sub>2</sub> characteristics for electricity charging the EV fleets*.

- The EV road transport scenarios reduce local pollution and noise.

#### **Economy:**

- Cost and lifetime of EV batteries much determine the EV economy and the outcome of the PHEV and BEV scenarios.
- Assuming '*reference*' battery cost development (COWI 2007) the PHEV scenario is close to break-even with the reference development. Beyond year 2025 annual socio-economic gains emerge. The BEV scenario, however, show annual deficits throughout the period, though relatively smaller later in the period.
- In an '*alternative*' battery cost development (US DOE 2010) the PHEV scenario is attractive from year 2015 and throughout the period. This is based on a marginal socio-economic analysis and excluding externalities. The BEV scenario becomes cost effective as well, though from beyond year 2020.
- CO<sub>2</sub> emission allowance costs are small put relative to costs of vehicle ownership, and have only minor impact on the above conclusions.

#### **Energy system robustness and flexibility: (Observations)**

- Road transport system robustness with respect to fuel price changes improves due to diversified energy resource basis in EV scenarios (and the security of energy supplies rises).
- Reduced operating costs in EV transport scenarios furthermore increase robustness.
- Oil substitution increases security of energy supplies and contributes to hedging oil price rises.
- EV flexibility as to when to charge may stabilize electricity market prices.
- EV flexibility as to when to charge increases the overall power system flexibility. (Important for integrating fluctuating power production, e.g. wind power.)

### 1.3 Power sector and grid aspects

- **EV and grid interaction.** Chapter 5

Important issues are the accessibility for EV's to charge from the grid, and the reverse process of discharging electric vehicles back into the grid, termed V2G (Vehicle to Grid). Focus areas in this respect are the infrastructure and communication requirements.

The integration between the electricity grid and the EVs contains a number of challenges with respect to the details for the implementation, including standardisation issues. In particular this is the case when aiming to harvest the full potential benefits of V2G functionalities. A range of preconditions and details are essential for the positive and controlled integration of EVs with the electricity grids.

Controlled (or smart) charging requires a *control signal from the power system* to the EV or to the charging post. This control can either be centralised or distributed. Such control may make use of *dynamic power prices* which can be used for all types of smart control, including the V2G. On top of this, an *appropriate payment scheme* between the EV user and the electricity supplier, including the distribution and transmission system operator (DSO and TSO) must be implemented.

Further work is needed in order to find appropriate solutions to the challenges.

- **Distribution grid – EV fleet interaction.** Chapter 6

EVs and Danish Distribution Grid interaction also poses a number of challenges:

- The home of the EV owner is where the EV is likely to be charged very often. Home loads would typically have a point of common coupling at the *0.4 kV level in Danish/European distribution grids*. Distribution feeders (0.4kV) may serve consumers of much different category in a neighbourhood. Therefore it is difficult to say in general how charging of EVs will affect loading of distribution grids.
- Fast charging or battery swapping charging alternatives would most probably be coupled at the 10 kV level.
- Comparing model results on *distribution grid loading in not controlled versus controlled EV charging* in low voltage grids shows that *controlled charging is increasingly important as the EV share rise in feeders*.
- Controlled charging *significantly reduces or delays the need for reinvestments in the grid*.
- *EVs as power system regulation tools* depend on the level of development of the EV-grid interface. For the DSOs (Distribution System Operators) two cases are important. Ability to:
  - Only start, stop and possibly regulation of charging of batteries (Fairly simple technical solutions)
  - Discharging of batteries to deliver energy to the grid (also known as vehicle to grid or V2G).  
V2G may require alternation of protection schemes in some distribution grids.

Start, stop and regulation of charging and V2G *may cause local overloading of distribution grids*. Nominal power of the charger and the potential control strategies for charging will determine the total impact EVs will have on the grid.



- Voltage flicker has been an issue when connecting electrical motors of high load. This is usually solved by adding soft starters to such motors. *EVs may require soft starting algorithms in charging equipment.*  
Using soft starting of charging may reduce the ability of the EV for delivering fast regulation services. *It does not, however, disqualify the EVs from delivering fast regulation services.*
  - Furthermore, attention should be paid to potential EV impact on harmonic distortion from chargers. Charging equipment shall meet Danish/EU requirements.
- **Transmission grid – EV fleet interaction.** Chapter 7

Similar to the situation in the previous two chapters, challenges are identified with respect to EVs and transmission power systems interaction:

- The EV impact on the power system *highly depends on the EV fleet charging strategy* applied.  
If the electrical vehicles *are charged in an uncontrolled mode* there will be a *considerable need for additional production and transmission grid capacity* to maintain the power adequacy and security of supply.
- The EV fleet impact on needs for increased grid capacity at transmission levels (> 100 kV) is relatively small. Whereas at the low voltage levels the impact of EVs on grid capacity requirements is an issue.
- Controlled charging focusing on day-ahead spot prices could significantly *improve the efficient use of wind power* and the existing controllable generation capacity.  
V2G functionality could further reduce the demand for additional power capacity.
- EVs can supply ancillary services. With or without V2G, *EVs can technically deliver primary, secondary and tertiary reserves.* As the individual EV is a relatively small resource (compared to power stations), *development of strategies and market solutions to take advantage of this source of ancillary services poses a challenge.*
- At transmission level, the *EV impact on demand for generation capacity and the potential impact on frequency stabilisation are specific focus areas.*

## 1.4 Overall transport and power system aspects

**Chapter 8 as well as Chapters 9 and 10** focus on analyses of power systems where electric vehicles are seen as integral part of the model. Chapter 8 presents the modelling of electric vehicles in this context, while chapters 9 and 10 present the analyses.

- **EV fleet and overall power system development / investments.** Chapter 9
  - Power supply system investments change due to EV-fleet flexibility
  - When charged/discharged intelligently *electric vehicles (EVs) can facilitate increased wind power investments* and can due to *vehicle-to-grid capability reduce the need for new coal/natural gas power capacities.*
  - *Wind power will likely provide a large share of the electricity for EVs towards 2030* in several of the Northern European countries.

- However, if not followed up by economic support for renewable energy technologies other than CO<sub>2</sub> quotas, wind power will, for the case of Denmark (and Germany and Sweden) *not contribute in providing electricity for EVs until the last part of the analysed period*. As a result, electricity demand for EVs will in Denmark (and Germany) in the short term likely be met by coal based power.
  - Large scale implementation of EVs is not sufficient to facilitate reaching the Danish wind target for 2030 by socio-economic optimality.
  - Effects of EVs on the power system vary significantly from country to country and are sensitive to variations in fuel and CO<sub>2</sub> prices.
  - In the last part of the period towards 2030 EVs can provide significant CO<sub>2</sub> emission reductions for the Danish energy system as well as for the Northern European countries as a whole.
- **EV fleet and overall power system interaction and operation.** Chapter 10

EVs and the value of smart charging:

The EV flexibility and its potential ability for controlled smart charging is a potential asset for the overall system. The quantification of such asset for EV in the overall system, however, involves considerable modeling and calculations that of course are associated with large uncertainty.

System operational costs are analysed using the Wilmar model. The analyses include power system investment costs derived using the Balmorel model.

The analysis has estimated two extremes of EV charging intelligence (not controlled versus controlled/smart charging) and how these might influence the total costs of an optimised future power system.

- In the case of *controlled/smart* EVs, the system cost to charge an electric vehicle, calculated as the difference in the *sum of investment costs and operational costs* between the smart scenario and the No EV scenario, was around 36 €/vehicle/year.
- In the case of *not controlled/dumb* EVs the system cost was around 263 €/vehicle/year.

Depending on the share of controlled EVs vs. not controlled EVs, the average cost should fall between these extremes – however, the supposed benefits of this additional flexibility was lost within modelling inaccuracies.

Most of the benefits come from the smart timing of charging. This can be divided between benefits accrued to the

- day-ahead planning phase,
- intraday adjustments to mitigate the forecast errors of
  - electricity demand and
  - variable generation.

Results *exclude grid and intra hour balancing related costs and benefits*. Restrictions in use of the flexibility of smart EVs are not as binding as they are likely to be in the real life.

## Discussion

The above conclusions relate to potential EV impacts in the *road transport sector*, the *power supply sector* and the potential synergistic interplay between the transport and power sectors.

A hypothesis for the present study has been that EVs can be seen as an enabling technology with respect to meeting CO<sub>2</sub> reduction aims and enabling integration of fluctuating electricity production, such as wind power. The above conclusions support such expectation.

EV flexibility as to when to charge/discharge improves the system integration of fluctuating production from wind power, and thus contributes synergy for concurrent CO<sub>2</sub> reduction and wind energy utilization in both sectors.

EVs can supply ancillary services. With or without V2G, EVs can technically deliver primary, secondary and tertiary reserves. And proper controlled charging significantly reduces or delays the need for reinvestments in the grid. A considerable part of the EV charging may occur during the night, where both transmission and production capacity are available with the present electricity consumption patterns in Denmark and Europe. However, challenges exist. One such is to develop (standard) systems being able to mobilise the potential EV regulation capabilities.

Generally for analyses behind the above conclusions is, that a number of externalities have not been quantified nor included. This is partly due to difficulties in quantifying externalities. Of such EV induced externalities can be mentioned:

- Reduced local pollution
- Oil substitution (reduced reliance on oil) and concurrent effect on hedging for increasing oil prices (and rising transport costs).
- Improved security of energy supplies (diversified transport energy basis).
- Increased transport and power system robustness and flexibility.

Furthermore, the present analyses have not in detail taken infrastructure cost in the transport and power sectors (e.g. relative to the electricity delivery per customer and eventual needs for strengthening the low voltage distribution grids) into account.

## 2 Introduction

### 2.1 Background

Global warming threats, uncertainty related to future energy supplies and the security of energy supplies are main issues in European Union energy policy. As response EU has set up targets (March 2007) for year 2020, the so called 20/20/20 targets. These aim to achieve at least:

- 20 % reduction in CO<sub>2</sub> emission below the 1990 level
- 20% coverage from renewable energy of total energy consumption
- 20% reduction in primary energy use compared with projected levels, to be achieved by improving energy efficiency (not binding).

These over all targets have been distributed on the member states, and adjusted according to preconditions.

Denmark has strengthened these ambitions and set up its own goal as to reduce CO<sub>2</sub> emissions with 40% relative to the 1990 level. This is to be achieved by increasing the share of renewables in Danish energy supply. By 2020 wind power is aimed to cover 50% of all electricity consumed in Denmark. And by year 2035 the aim is to have the total electricity and heat consumption based on renewable energy sources. Moreover, it is a stated political aim that all fossil fuels in the Danish energy system have been phased out to zero by year 2050. And renewables are aimed to cover all energy consumption in Denmark by 2050 (ref.104).

Presently the EU road transport sector relies to almost 100% on the fossil fuels gasoline and diesel. Vulnerability to potential fuel supply shortages, rising fuel prices and difficulties in meeting CO<sub>2</sub> emission reduction requirements constitute heavy challenges for the transport sector. This dependence may be altered radically by a transition towards electricity based drive trains utilizing electricity charged from the grid.

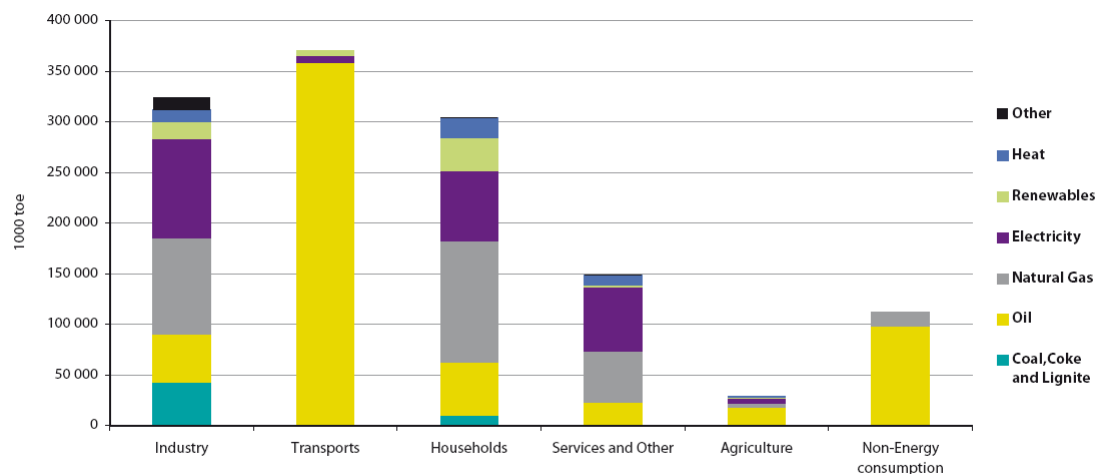

Source: Eurostat

Figure 8 EU-27: Final energy and non-energy consumption by fuel and end-use sector, 2006

(Source: Eurostat. Panorama of energy 2009)

Integration of electric vehicles (EVs) in the transport sector may in the future significantly reduce the emission of pollutants, and improve air quality in local and urban areas. Furthermore, through EVs developments in the power supply sector may have direct implications for the road transport emissions. Options in the power supply sector, as to reduce CO<sub>2</sub>-emissions in particular, can become options for the transportation sector as well.

Grid electricity in Europe and Denmark is almost independent of the oil based fuels, but relies on a range of energy sources, among which nuclear, coal and natural gas presently dominate the generation (Figure 9).

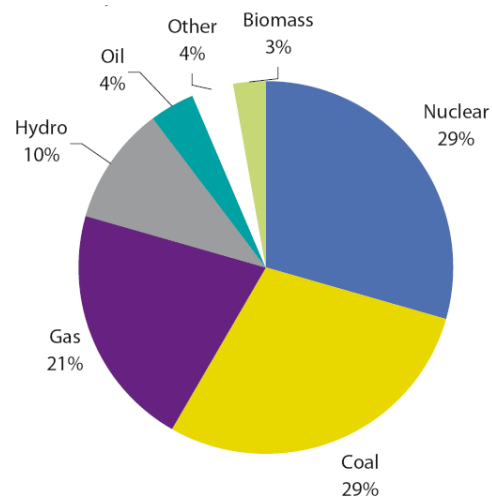

Source: Eurostat

Figure 9 EU-27: Electricity generation in 2006: Share by source.

(Source: Eurostat. Panorama of energy 2009)

Strengthening the transition towards renewables and non-CO<sub>2</sub> emitting energy technology for power generation may in future bring, both diversity in energy resources for power generation and very low GHG emission, ultimately leading to CO<sub>2</sub> neutral power generation, and consequently CO<sub>2</sub> neutral electricity based road transport.

Power sector CO<sub>2</sub> emissions are quota regulated, whereas CO<sub>2</sub> emission from transport lies outside the quota system. By the transition towards EV road transport CO<sub>2</sub> emission reduction is achieved outside the quota system. EVs increase the electricity demand and thus add constraints for the power sector as to fulfill its quota obligations. Thus, reasoning within this scheme of regulation one may argue that EVs do not imply increased CO<sub>2</sub> emission, and consequently EVs are emission neutral. The power sector may get a large new market serving emerging EV fleets, but it must supply this rising demand without increasing the emission of CO<sub>2</sub>.

The potentially very large flexibility in electricity demands from electricity based road transport may facilitate a transition towards the future non-fossil and CO<sub>2</sub>-neutral power sector. The present project aims to illustrate and analyze some of these options, focusing on the case of Denmark mainly. The analysis aims to quantify potential consequences for the Danish transport- and power sectors, being viewed as integral parts of, and interacting with, the Northern European power system.

## 2.2 Recent developments in electric vehicles

The entry of electric cars in volume at the passenger car market has been expected for more than a decade. The market share of EVs is, however, still close to zero. Mainly battery cost and capacity and the EV range, relative to the ICE vehicle, have been severe barriers for creating an EV mass market. And potential gains, via volume production and economy of numbers driving down costs, have not been achieved.

Lately broader recognition of the multitude of benefits EVs bring has emerged. Likewise recognition of the need to develop alternatives to the conventional oil based ICE vehicle grows. Furthermore, positive developments on battery technology, for the battery specific energy, capacity, lifetime and cost (primarily drawn by needs in the IT sector), have induced new EV optimism and given the EV development renewed momentum.

Government incentives (in e.g. USA, Japan, China, Europe) and a renewed belief that a mass market for EVs can develop have accelerated investments in EV production and the supply chain for EV components. And mass produced EVs are now entering the market.

## 2.3 This project

The present project analyses electric vehicles in relation to the challenges mentioned above.

This is done by outlining the technical and economic conditions for applying EV to a larger extent. It includes in particular expected developments for EV batteries, and development of scenarios for EVs in the road transport sector. It also includes the interplay between EVs and the electricity system. This interplay is taking place and treated here at various levels, viz., between the EVs and the electricity network through the electrical installations and couplings; between the EV coupling to the network and the distribution network; and further on to the transmission system and to the electricity generation units.

Analysis of the possible roles of EVs in a future electricity system is explored by development and application of models for analyzing investment and operation for an electricity system where EVs are seen as an integral part.

## 2.4 Report structure

The following part of the report consists of eight chapters each with their focus.

**Chapter 3: The electric vehicle (EV) status and expected development** relates to the individual passenger vehicles for road transport and their potential technical development. Electric vehicles (EVs) and the conventional internal combustion engine vehicle (ICEV) are in focus. Analyses are here performed on *average vehicle* level.

**Chapter 4: EV and road transport sector scenarios** focuses on the Danish transport fleet and scenarios set up for EVs entering the fleet. Analyses are here performed on transport *fleet* level.

**Chapter 5: EV and grid interaction** focuses on the electric vehicle interacting with the local grid including standardization issues and options/consequences of EVs linked to grids.

**Chapter 6** and **Chapter 7** have the overall power system consequences in focus. Chapter 6 includes electricity distribution grid issues and overall consequences of large scale EV deployment.

**Chapter 7: EVs and their impact on transmission systems** focuses on transmission grid consequences of set up scenarios and options for power system and EV fleet interacting.

**Chapter 8 as well as Chapter 9 and 10** focus on analyses of power systems where electric vehicles are seen as integral part of the model. Chapter 8 presents the modelling of electric vehicles in this context.

**Chapter 9: Balmorel model results – EVs and power system investments** covers issues on system integration of wind power in particular and technical power regulation issues at overall system level. This includes the potential EV-fleet contributions in this context.

**Chapter 10: Wilmar model results – EVs and the value of smart charging** covers issues on system integration of wind power in particular and technical power regulation issues at overall system level. This includes the potential EV-fleet contributions in this context.

## 3 The electric vehicle (EV) status and expected development

The stage of development for the electric vehicle and assumptions on the future development of such vehicles are topics of this chapter. Of particular importance are the parallel technical development for the electricity based vehicles (EVs) and the conventional internal combustion engine vehicles (ICEVs), and the related CO<sub>2</sub> emission. Further issues are the vehicle costs, the expected battery cost development, costs of vehicle operation and ultimately the overall costs of ownership, using the vehicles. A socio-economic point of view is applied.

The focus is put on the road transport fleet segment: Passenger cars and light commercial vehicles (LCVs) < 3.5 ton. This combined segment covers about 2/3 of the road transport energy usage in the Danish case, and about half of the total transport energy consumption. Road transport energy consumption is 76.8% of the total Danish transport energy use in 2010.

The analysis in this chapter looks at the ‘average’ vehicle and its development over time, while the following chapter 4 will treat vehicle fleet development over time.

### 3.1 Road transport vehicles in focus

As basis for setting up scenarios (chapter 4) assumptions are made on the development of the reference vehicle (ICEV) and the alternative electricity based vehicles (EVs) up to 2030 for the fleet segment in focus. Assumptions concern the vehicle specific energy consumption, investment costs, the vehicle life-time, and costs for operation and maintenance.

The expected ‘close to average’ fleet vehicles and the type of drive trains in focus are:

- Reference: Internal Combustion Engine Vehicle (ICEV)
- Alternative: Hybrid Electric Vehicle (HEV)
- Alternative: Plug-In Hybrid Electric Vehicle (PHEV)(ICE extends range)
- Alternative: Battery Electric Vehicle (BEV) (All-electric)

Operating in EV-mode the alternative vehicles generate virtually no air pollutants. Thus, substituting the conventional internal combustion engine vehicle (ICEV) by such alternative vehicles local (pollutant/toxic) emissions to air can be reduced or eliminated. Likewise, depending on the power supply system in question the emission of greenhouse gasses related to the energy chain charging the EV-based vehicles may be reduced or even eliminated.

#### Level of vehicle description

The level of detail for the description of these future vehicles is limited to very few technical characteristics important for the scope of our overall analysis, the potential transport sector and power system interaction. We aim to define the future ‘close to average’ vehicles that may be expected to enter this fleet segment during the period 2010-2030.

Much detail in defining the ‘close to average’ vehicle is less important for our scope. More important is that consistency is maintained across vehicles of different type, utilizing different drive trains *within each vintage group* defined. The *vehicle ‘frame’ is defined in versions of*



conventional reference ICEV and in versions of the alternative HEV, PHEV or BEV vehicles. The drive train only differentiates the vehicles of a given vintage.

For each type of vehicle technical developments over time are assumed. As effect, the vehicle drive trains improve for vintage groups to come, up to 2030. And it is assumed that the vehicles deliver equal or equivalent services to the consumer in this segment (or sub-segment), apart from the vehicle range per charge.

### **Annual driving**

To maintain compatibility of results, it is assumed for this analysis, that annual driving and the patterns of use are equal for all vehicles in a vintage, despite the type of drive train. Thus, e.g. the BEVs and the conventional ICEVs are assumed to support the same annual driving and to deliver ‘corresponding services’, which of course may not be the case for all potential application sub-segments. This assumption is more ‘straight forward’ comparing the PHEV and ICEV.

### **Issues in focus**

Apart from the technical specification of the vehicles in particular two issues are drawn forward as important in the analysis. One is the GHG and in particular CO<sub>2</sub> emission footprint of the vehicles and thus the

- **CO<sub>2</sub> characteristics of power supply systems.**

The second is the vehicle cost development. And the dominating issue in this respect is

- **EV battery costs development.**

The battery cost is the most important cost element determining the viability of the EV’s. Consequences of alternative developments on this are illustrated.

## **3.2 Assumptions on vehicle energy consumption**

As mentioned the fleet average vehicle *frame* has been assumed to be the same despite the type of drive train utilized for each vintage group defined. Within a vintage group only the type of drive train differs. The following further general links among the defined fleet average vehicles, carrying different drive trains, have been assumed:

- PHEVs operated in HEV-mode have the same specific energy (gasoline/diesel) consumption as the defined HEV vehicle.
- PHEVs operated in BEV-mode (or charge depletion mode) have the same specific energy consumption (electricity) as the defined BEV vehicle.
- HEVs have fuel consumption equal to 65% of the ICEV within a vintage group.

These general relations have been assumed for each vintage group of future vehicles. And these characteristics are basic for the following partial analyses.

The main characteristics assumed for the ‘close to average’ passenger vehicles and light commercial vehicles (LCVs) < 3.5 ton that may enter the future fleet are shown in *Figure 10* below.

### ICEV fuel consumption:

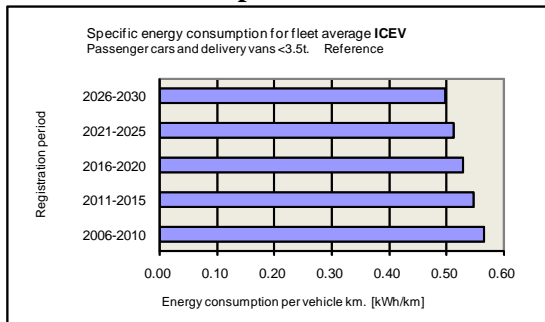

### HEV fuel consumption:

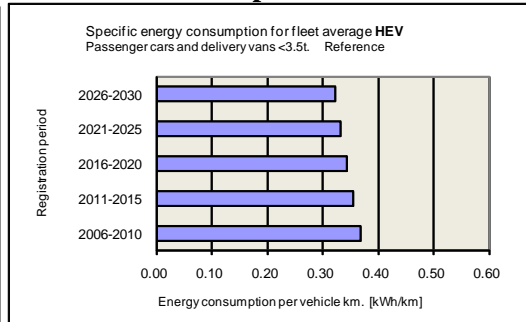

### PHEV electricity and fuel consumption:

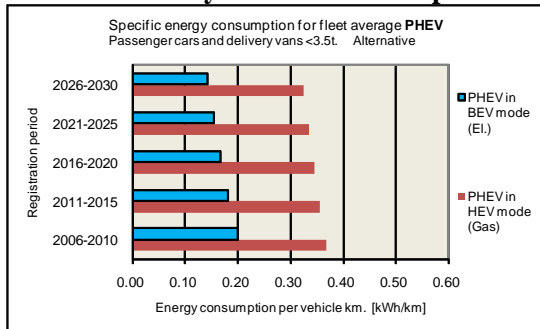

### BEV electricity consumption:

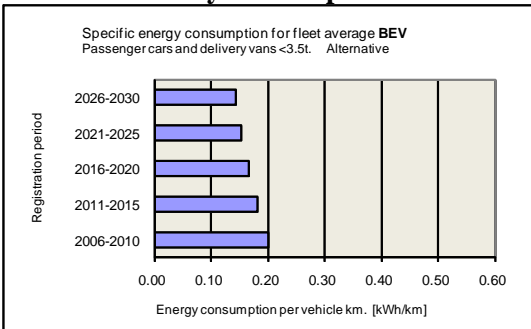

Figure 10 Assumptions on ICEV, HEV, PHEV and BEV specific energy consumption for vintage groups up to year 2030. [kWh/km] (gasoline/diesel or electricity). Reference: COWI 2007 [31] and EPRI 2007 [32]

Energy efficiency improvements over time, for future vintages, are generally assumed for all vehicle types. However the mature conventional ICEV technology has relatively lower efficiency gains than the less mature emerging alternative PHEV and BEV vehicles.

### Vehicle comparisons: Specific energy consumption

For comparison Figure 11 below shows mileage assumption for the ICEV and the corresponding HEV and PHEV operating in fuel consuming HEV-mode. The mileage is expressed in units of km/liter of fuel consumed.

### ICEV, HEV & PHEV: [km/liter]

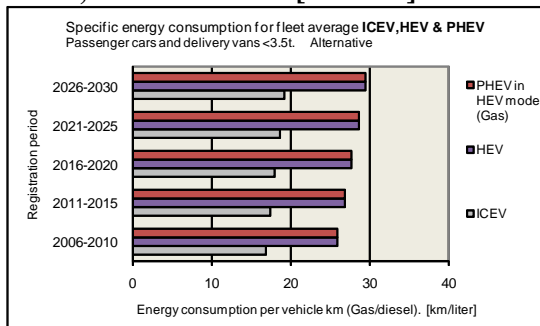
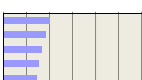

Figure 11 Comparison of ICEV, HEV and PHEV assumptions on the specific fuel consumption (gasoline/diesel) for vintage groups to year 2030. [km/ liter fuel]



The HEV and PHEV operated in HEV-mode are assumed to achieve equal mileage. Over time both vehicles moderately increase mileage as seen from Figure 11. And as mentioned, the hybrid vehicles are assumed/estimated to consume only 65% of the fuel consumed by the equivalent conventional ICEV.

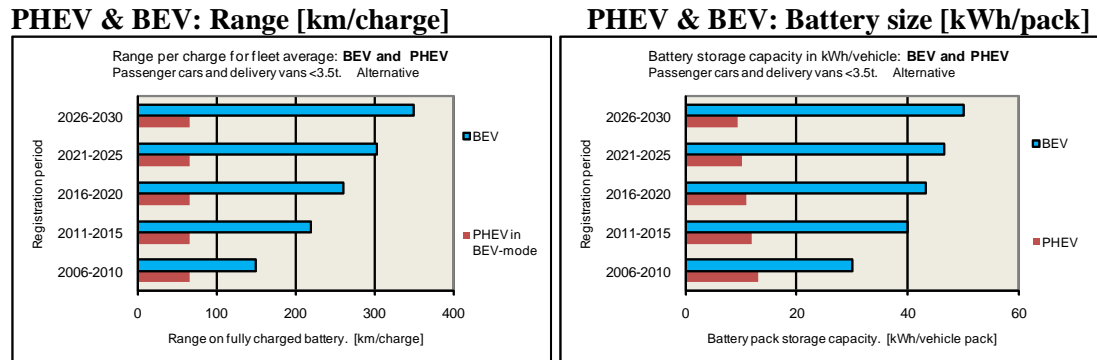

Figure 12 Assumptions on PHEV and BEV range per charge and size of battery pack for vintage groups to year 2030.

EV (PHEV and BEV) electric mode range is limited by the size of the battery. For the present analysis the PHEV battery is assumed to deliver the range of 65 km's in charge depletion mode (or BEV-mode) starting on a fully charged battery. This is generally assumed for all PHEV vintage groups. For the BEV an increasing range per charge, for future vintage groups entering the fleet, has been assumed. The BEV registered 2010 is assumed to get 150 km on average per fully charged battery (despite time of year etc. and vehicle age in fleet) and this range is assumed to increase towards 350 km per fully charged BEV entering the fleet in the vintage period 2026-2030 (Figure 12 to the left).

The corresponding size of battery needed for the BEV and PHEV, expressed in kWh/battery pack, is shown in Figure 12 to the right. Due to drive train efficiency improvements over time relatively smaller electricity storage capacity is required. E.g. PHEV battery pack size in kWh/battery pack is assumed to decrease even though the range in charge depletion mode is maintained at 65 km per fully charged battery.

**PHEV: 77% of annual driving via Electricity**

As mentioned it has been generally assumed that the PHEV vehicles will have a range of 65 km on a fully charged battery when operated in electric-mode only (the PHEV operated in BEV-mode). And the PHEV operated in HEV-mode is assumed to have range about equal to the defined HEV vehicle.

For the present analysis it is assumed that the PHEV annual consumption of the propellants electricity and gasoline/diesel can be split according to transport patterns reflected in Figure 13. The figure shows the annual driving for this fleet segment distributed on the *daily distances* driven. It reflects driving habits/patterns in Denmark corresponding to the fleet segment passenger cars and light commercial vehicles of weight below 3.5 ton.

It will be assumed that longer daily trips start out on fully charged batteries and that recharge during the day is not an option. (Which of course, is a rude and 'conservative' assumption.)

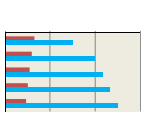

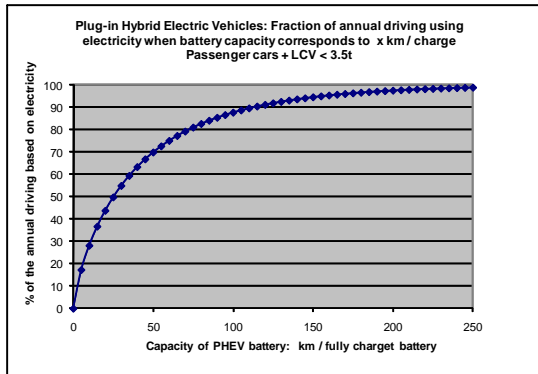

Figure 13 Plug-in Hybrid Electric Vehicles (PHEV): Percents of annual driving using electricity when battery capacity corresponds to  $x$  km / charge. Passenger cars + LCV < 3.5t. Source: Estimated (Weibull) distribution for daily distance driven (in this Danish fleet segment) based on data from ref. [45], DTU Transport: ‘Transport Vane Undersøgelse: 2006+2007’.

According to Figure 13 a PHEV range of 65 km in BEV-mode corresponds to 77% of the annual driving. Accordingly, using the defined PHEV, 77% of the annual driving may be electricity based in the Danish case. The PHEV may typically be fully recharged during nights.

This percentage of the PHEV vehicle propellant consumption is electricity charged from the grid. The remaining 23% of the annual driving uses conventional fuel, gasoline or diesel. For the Danish fleet case it has been assumed that 50% of the conventional fuel used is gasoline and 50% is diesel. This is in accordance with the present fuel mix in Denmark for these road transport segments.

### 3.3 Assumptions on vehicle CO<sub>2</sub> emission

For the ICEV and HEV the specific CO<sub>2</sub> emission is a direct consequence of the vehicle energy efficiency and the type of fuel used. Gasoline and diesel fuel the conventional ICEV and the HEV and a split on these fuels, also for the future fleet, is assumed to be 50%/50% as mentioned above. Figure 14 below shows the corresponding specific CO<sub>2</sub> emission.

#### ICEV CO<sub>2</sub> emission:

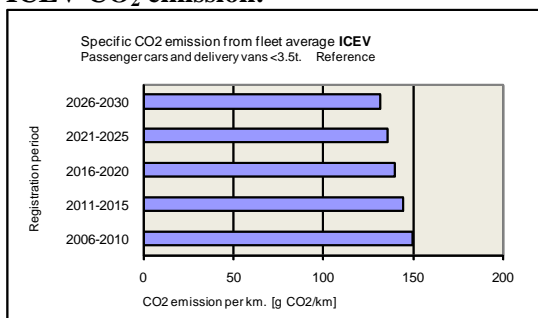

#### HEV CO<sub>2</sub> emission:

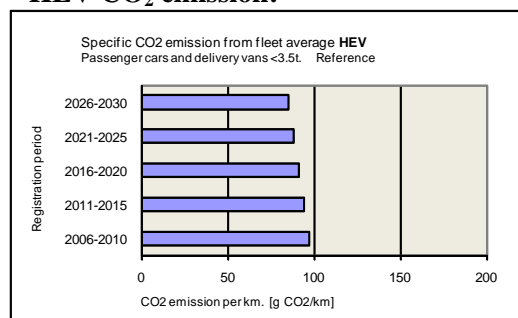
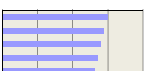

Figure 14 Assumptions on ICEV and HEV specific CO<sub>2</sub> emission. [g CO<sub>2</sub>/km]

For the electricity based vehicles, PHEV and BEV, the specific CO<sub>2</sub> emission depends of the power source and the power system development over time and during the vehicle life.

To illustrate effects of the power system development on the CO<sub>2</sub> emission from EV based vehicles three scenarios or cases for the system development are assumed for the (marginal



and partial) analyses to follow. The average CO<sub>2</sub>-characteristics of electricity supplied up to year 2030 in Denmark is derived for the three cases:

- **CO<sub>2</sub>Case I** : **Marginal** electricity production CO<sub>2</sub> -characteristics. Reference. The power system develops according to forecast from The Danish Energy Authority (DEA, April 2010) [32].
- **CO<sub>2</sub>Case II** : **Average** electricity production CO<sub>2</sub> -characteristics. Reference. The power system develops according to forecast from The Danish Energy Authority (DEA, April 2011) [34].
- **CO<sub>2</sub>Case III** : **Average** electricity production CO<sub>2</sub>- characteristics. Alternative. The power system develops from today's configuration and CO<sub>2</sub> -characteristics via a linear phasing out to zero of all fossil fuels used in the system by year 2050.(This is stated as a political aim for Denmark, October 2010.)

The assumed developments are shown in Figure 15. According to the DEA development (reference) the specific CO<sub>2</sub> emission for a **marginal** electricity demand ('or demand increase') remains close to constant in the period 2010-2030 at a level of about 850 kg CO<sub>2eq</sub>/MWh<sub>el</sub>. This development is termed **CO<sub>2</sub>Case I** and corresponds approximately to electricity produced from coal fired condensing plants.

In **CO<sub>2</sub>Case II** (Figure 15) the specific CO<sub>2</sub> emission in **average** for electricity consumed in Denmark descends during the period from 387 kg CO<sub>2eq</sub>/MWh<sub>el</sub> in 2010 to 252 kg CO<sub>2eq</sub>/MWh<sub>el</sub> year 2030 according to DEA forecast (April 2011). However, assuming (a linear) phasing out of all fossil fuel based power generation by year 2050, the specific CO<sub>2</sub> emission is reduced to half by year 2030, as seen for **CO<sub>2</sub>Case III** in Figure 15.

**A:** Electricity from grid CO<sub>2</sub> emission.

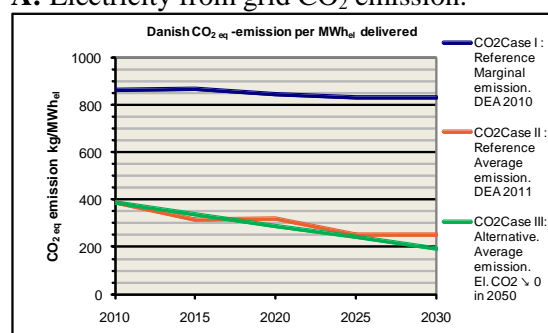

**B:** Vehicle lifetime CO<sub>2</sub> emission per kWh.

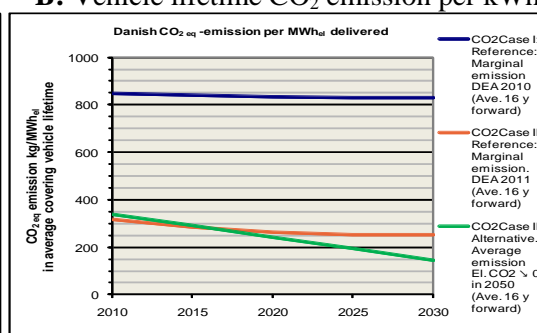

Figure 15 A: Assumed development for the specific CO<sub>2</sub> emission related to (**marginal and average**) electricity consumption in Denmark until year 2030. [Source: DEA 2010, DEA 2011].

Figure 15 B: **Vehicle lifetime average** specific CO<sub>2</sub> emission: The average CO<sub>2</sub> emission per kWh electricity used by an EV, when emissions are averaged over the vehicle lifetime, 16 years forward. Based on 'A' assumptions. [kg CO<sub>2eq</sub>/MWh<sub>el</sub>]

In Figure 15 B one should note that the 'Vehicle lifetime CO<sub>2</sub> emission per kWh' includes emission during the total (in fleet) lifetime of the vehicle. These numbers thus comprise future changes in CO<sub>2</sub>-characteristics due to power system development during the EV vehicle lifetime, from entering the fleet and 16 years ahead.

## EV CO<sub>2</sub> emission per km: CO<sub>2</sub>Case I, II and III

For individual PHEVs and BEVs the specific CO<sub>2</sub> emission per km of driving changes over years in accordance with developments in the power supply.

Figure 16 shows specific CO<sub>2</sub> emissions per km driven that reflects the total vehicle lifetime emission. Vehicle vintage groups differ, both due to the technical development for vehicles, and due to power system developments taking place during the vehicle lifetime. The combined assumptions made on vehicle and power system developments are included in Figure 16.

### PHEV CO<sub>2</sub> emission: CO<sub>2</sub>Case I

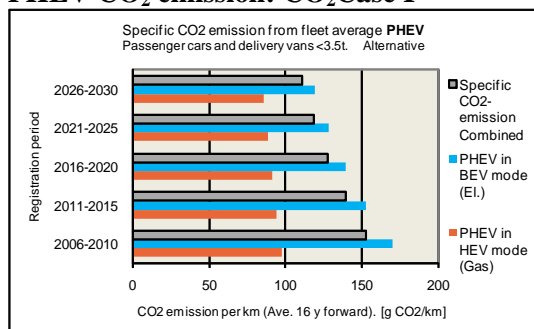

### BEV CO<sub>2</sub> emission: CO<sub>2</sub>Case I

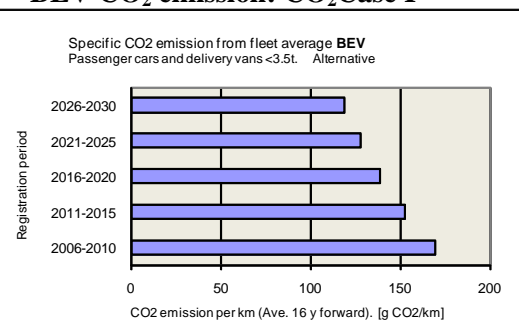

### PHEV CO<sub>2</sub> emission: CO<sub>2</sub>Case II

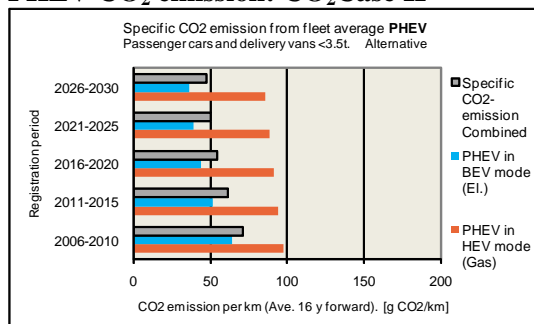

### BEV CO<sub>2</sub> emission: CO<sub>2</sub>Case II

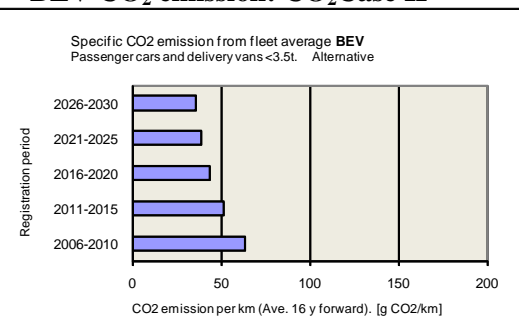

### PHEV CO<sub>2</sub> emission: CO<sub>2</sub>Case III

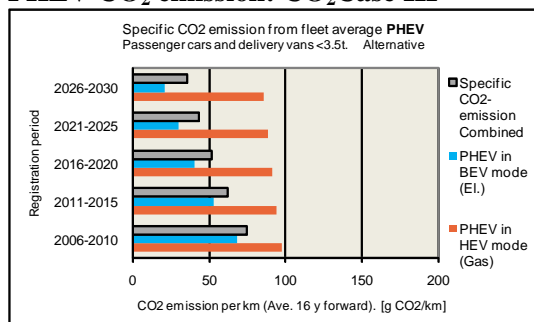

### BEV CO<sub>2</sub> emission: CO<sub>2</sub>Case III

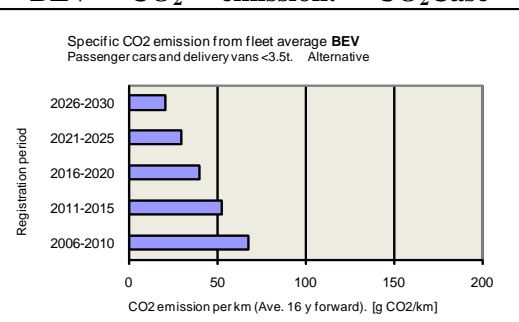

Figure 16 Assumptions on PHEV and BEV life time average specific CO<sub>2</sub> emission in CO<sub>2</sub>Case I (DK-DEA 2010 reference. **Marginal** electricity consumption CO<sub>2</sub>-characteristics ), CO<sub>2</sub>Case II (DK-DEA 2011 reference. **Average** electricity consumption CO<sub>2</sub>-characteristics), and CO<sub>2</sub>Case III (Alternative. **Average and linear descend** to zero CO<sub>2</sub> emission in 2050) for the power system development. [16 years forward average: g CO<sub>2</sub>/km]

Figure 16 reflects the power supply development assumptions shown in Figure 15 for the three cases. The figure shows e.g. that the year 2030 vintage BEV emits about 20g CO<sub>2</sub> /km on average during its 16 years of operation (2030-2046) assuming the CO<sub>2</sub>CaseIII alternative power supply development. And assuming CO<sub>2</sub>CaseI (reference and CO<sub>2</sub>-characteristics for

marginal power supply via this system) the same BEV vehicle would emit about 120g CO<sub>2</sub> /km.

In CO<sub>2</sub>CaseI (assuming marginal supply from the reference system) the power system CO<sub>2</sub> characteristics are close to constant throughout the period 2010-2030. Upper right sub-Figure 16 shows specific CO<sub>2</sub> emissions for the BEV vintages entering the fleet in the period. Reduced specific emissions over time seen from this sub-figure are thus result of the assumed BEV efficiency improvements in the period.

### Relative CO<sub>2</sub> emission: BEV, PHEV, HEV relative to ICEV

An overview of CO<sub>2</sub> consequences for the alternative vehicles in future vintage groups is given in Figure 17.

All vehicles within a vintage group are assumed to have the same driving pattern and annual driving in a given year. Thus, numbers shown are comparable across the type of vehicle. The CO<sub>2</sub> emission of the alternative vehicles relative to the conventional ICEV are shown for CO<sub>2</sub>Case I and CO<sub>2</sub>Case III assumptions on power system developments.

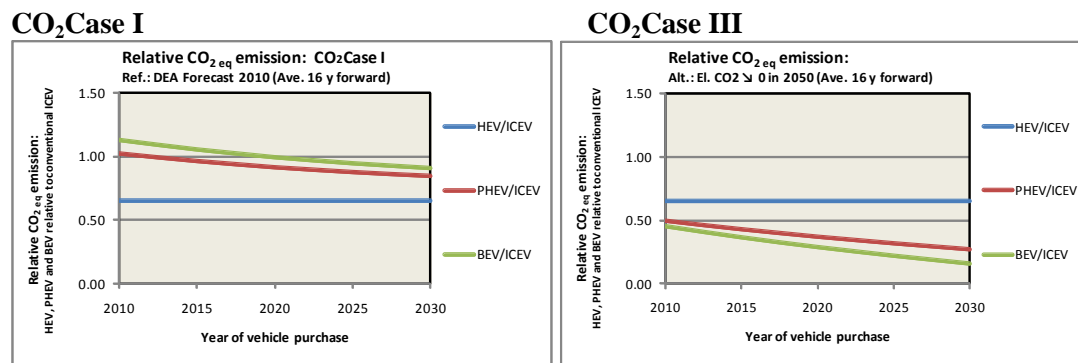

Figure 17 Comparison of CO<sub>2</sub> consequences for the alternative vehicles assuming CO<sub>2</sub>Case I and CO<sub>2</sub>Case III for the power system development.

Focussing on CO<sub>2</sub>Case I (Figure 17 left) and emission from the battery electric vehicle relative to the conventional vehicle (BEV/ICEV) the figure shows that BEVs exceed the CO<sub>2</sub> emission of the ICEV up to about year 2018. From then on using a BEV is expected to reduce CO<sub>2</sub> emission relative to the ICEV.

As mentioned above, the CO<sub>2</sub>Case I specific CO<sub>2</sub> emission for electricity is close to constant throughout the period and therefore the BEV CO<sub>2</sub> footprint declining during the period is due mainly to vehicle efficiency improvements for future BEV vintages relative to future ICEV vintages. As mentioned, this reflects the assumption saying that the ICEV technology is a close to mature technology, whereas the BEV technology presently is at an earlier stage of development having a relatively larger potential for further development.

In marginal CO<sub>2</sub>Case I the PHEV of today in Denmark has almost the same CO<sub>2</sub> emission as the ICEV. And in this case future vintages show only a moderate CO<sub>2</sub> reduction relative to the ICEV.

In CO<sub>2</sub>CaseIII the specific CO<sub>2</sub> emission for electricity on average from the system is assumed to descend linearly from the level of today to zero in year 2050. This assumption makes the alternative vehicles in our focus superior by far in reducing the vehicle CO<sub>2</sub>-

footprint, when compared to the future ICEVs. Future vintage groups of the alternative vehicles will perform substantially better than the future conventional ICEV. Moreover, in CO<sub>2</sub>Case III both the BEV and PHEV have specific CO<sub>2</sub> emission increasingly lower than the HEV.

The electricity based vehicles, PHEV and BEV, get very low GHG footprint due to significant CO<sub>2eq</sub> emissions reductions being achieved in the power supply system in CO<sub>2</sub>Case III.

### 3.4 Cost of vehicle ownership

Costs of ownership for the BEV, PHEV, HEV and ICEV type of vehicles is calculated seen from a socio-economic point of view, and thus based on socio-economic assumptions. The presented calculations are *marginal* in the sense that use of the alternative vehicles does not influence the general assumptions made e.g. on power system developments. And the analysis is *limited* in the sense that only few aspects are taken into account when calculating the vehicle ownership costs seen from the perspective of society at large. Only vehicle investments, maintenance costs and cost of operation are included in the present analysis. *Infrastructure costs are thus not included, and so-called externalities are not included* (in contrast to some subsequent chapters).

#### Socio-economic assumptions

The socio-economic analysis is based on so-called factor prices, that is prices without tax, subsidies and alike. And a socio-economic rate of interest or time preference is used.

For the present socio-economic analysis of vehicles ownership cost the following main assumptions have been made:

- Rate of interest: 5% p.a.
- Time period: 2010-2030  
Time horizon for the analysis: 20 years  
Vehicles entering the fleet year 2030 involve assumptions up to year 2030+16.
- Prices: 2008 price level
- 1\$ = 6 DKK

#### General vehicle assumptions

General assumptions related to the defined vehicles:

- Vehicle curb lifetime: 16 years
- Vehicle usage patterns assumed equal for all vehicles.
- Vehicle investment, exclusive drive train, assumed equal for all vehicles.
- Battery lifetime: Up to 16 years beyond 2020 (Figure 18 Battery cost scenarios assumed for both PHEV and BEV vehicles).
- Reinvestments included for vehicle components with lifetime shorter than assumed vehicle lifetime.
- Vehicle end of life value equal to zero.
- Battery end of vehicle life value assumed to zero. (Disputable assumption.)
- Termination values beyond time horizon: P.t. not relevant.
- Annual socio-economic operation and maintenance costs (Figure 22).



Cost of vehicle ownership calculated for the individual vehicle covers the use of the vehicle during its lifetime. A vehicle entering the fleet, say in year 2020, is on average assumed to be in use until 2036. The present value of all costs covering the period 2020-2036 is levelized over the same period and this average annual cost of ownership is assigned to the vehicle bought year 2020.

Many parameters change during the period analysed. New vintages of vehicles develop over time. And technical performance, costs etc. are assumed to change, according to the assumptions described. Likewise, fuel and electricity prices and power system CO<sub>2</sub> characteristics develop over time. As power system reference scenario, the present (*marginal* and *partial*) analysis takes its starting point in forecasts published by the Danish Energy Authority, April 2010 and April 2011.

The socio-economic analyses focus on calculating the key number ‘average cost of vehicle ownership’ or just the ‘*cost of ownership*’ to sum up consequences of the multitude of variables.

To illustrate uncertainty and the relative impact of some key parameters sensitivity analyses are carried out concerning:

- Battery cost development
- Grid electricity specific CO<sub>2</sub> emission
- Price on CO<sub>2</sub> emission allowance
- Fuel and electricity price development

In chapter 4 (EV and road transport sector scenarios), analysing aspects at fleet level, consequences for *the particular years* are illustrated. In this chapter 3 however, the individual vehicle is in focus and analyses cover the *vehicle lifetime*. Average levelized costs per year using the vehicle are calculated covering the total lifetime of the individual vehicle, 16 years ahead from purchase.

## EV battery cost assumptions

Two battery cost scenarios are assumed. These EV-battery cost scenarios will be memo-technically named:

- **BatCost I :** EV battery cost development scenario based on (ref.: COWI (2007) [31] & IEA (2009) [43])
- **BatCost II:** EV battery cost development scenario based on ref.[xx]: DOE, The Recovery Act: Transforming America’s Transportation Sector, Batteries and Electric Vehicles, July 14, 2010.

In the BatCost I scenario the cost per kWh of battery storage capacity assumptions distinguish between the PHEV and BEV type of batteries. In the BatCost II scenario the cost per kWh of battery storage capacity is assumed to apply both for PHEV and BEV type of batteries, despite the differing requirements for power/energy capacity. Figure 18 illustrates the assumptions related to the PHEV and BEV.

## Costs [\$ /kWh battery storage capacity]

## Battery lifetime [Years]

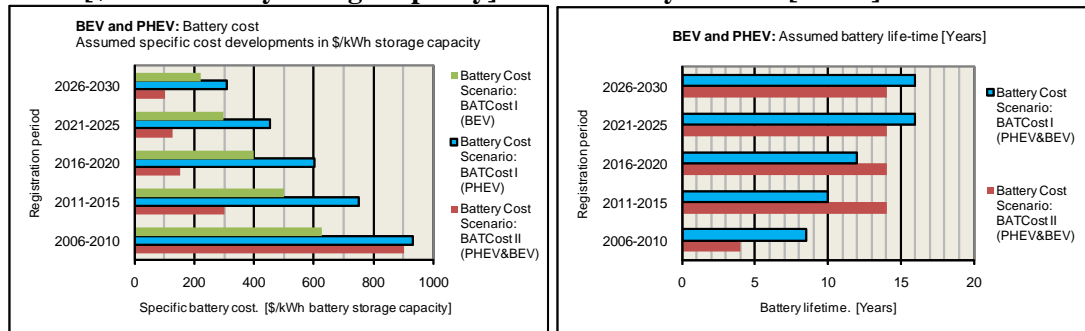

Figure 18 Battery cost scenarios assumed for both PHEV and BEV vehicles.

The US DOE expects very fast learning and cost reductions for EV batteries, partly due to the substantial investments made by the US Obama Administration in sectors related to battery research and development, and battery mass production. In particular the short term cost reduction is substantial, and in 2015 the battery lifetime is assumed to have improved to 14 years. Battery long term costs, beyond year 2025 are according to Scenario BatCost II expected to drop to 100\$/kWh stored. This is considerable cheaper than expected in the scenario termed BatCost I, which assumes a much less aggressive battery cost reduction development.

Generally it has been assumed that the 'end of life' value of the batteries is zero. This has been assumed despite an after vehicle life value of EV batteries can be expected e.g. for stationary applications. Taking into account a discount rate and the life-time assumptions for batteries, cf. Figure 19, the net present value of such second application will be a minor fraction of the battery net cost. Combining battery cost, battery lifetime and annual fuel and maintenance costs, cf. Figure 20 and Figure 21, the zero 'end of life' value assumption seems not to be crucial.

As mentioned, infrastructure costs are not included in the present analysis. In case an electric vehicle is to be connected to the electricity grid at home, a connection facility has to be established. It is debatable whether to consider this as part of infrastructure or not; in any case, it is not included here. Based on scarce experience it is estimated that the cost will be around 1000\$ and the life-time of the installation will be long, thus neither this assumption seems crucial. (Installations in public places are considerable more costly per unit [18], but are shared by more users.)

## Annual fuel/electricity costs and vehicle maintenance costs

Reference data on fuel cost development and the cost of electricity at the consumer are based on forecasts from the Danish Energy Authority, April 2010 [32]. Vehicle maintenance costs assumed are based on reference COWI 2007 [31].

The annual driving distance is assumed equal for all vehicles in a given year. However the annual driving is assumed to increase in time from well 17000km/year in 2010 to close to 19000km/year in 2030.

### Fuel/Electricity costs [\$/year]

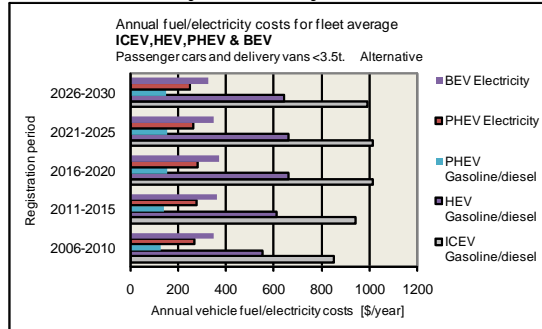

### Maintenance costs [\$/year]

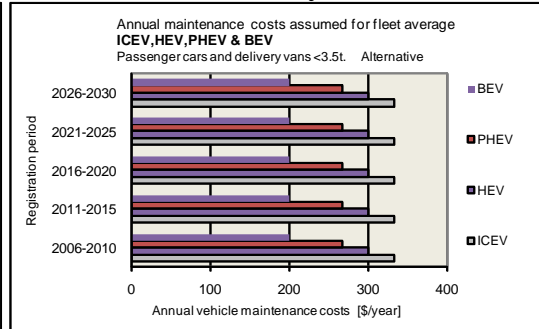

Figure 22 Assumption made on the vehicle annual fuel/electricity costs and maintenance costs. Fuel and electricity prices are based on DEA forecasts, April 2010.

It has furthermore been assumed that the PHEVs have 77% of the annual driving in BEV-mode, using electricity.

### 3.5 Overview: Cases analyzed for individual vehicles

Comparative socio-economic analyses (marginal/partial) are carried out at vehicle type level. Costs of vehicle ownership are calculated based on the framework conditions outlined below.

The alternative EVs are compared to the conventional ICEVs. This is carried out for different vintage stages for the vehicles covering the period 2010-2030.

Basic framework assumptions:

- BEV, PHEV and HEV cost of ownership relative to ICEV
  - Reference basis:*
    - Energy price development: Danish Energy Authority (DEA). Baseline forecast from April 2010.
    - CO<sub>2</sub> emission per kWh electricity: DEA Baseline forecast from April 2010 (*marginal* supply characteristics) and April 2011 (*average* supply characteristics).

Sensitivity analyses:

- CO<sub>2</sub>-emission per kWh electricity:
  - Reference* development: Danish Energy Authority. Forecast April 2011 (*average* supply characteristics).
  - Alternative* development:
    - Linear decrease in period 2010-2030: From present level in 2010 to zero in year 2050.
- Energy price development:
  - Reference* development: Danish Energy Authority. Forecast April 2010.
  - Alternative* developments:
    - Linear %-increase in period 2010-2030: +0% in 2010 to +20% in 2030
    - Linear %-decrease in period 2010-2030: -0% in 2010 to -20% in 2030
- Battery cost development in \$/kWh in period 2010-2030:
  - Reference* development: Via references: COWI et al 2007, [xx] (Check)
  - Alternative* development: Battery price development according to:
    - DOE: The Recovery Act: Transforming America's Transportation Sector. Batteries and Electric Vehicles; 14 July 2010.

## Ownership cost: Reference assumptions

The cost of ownership is expressed as the annual average cost (annuity) covering the total lifetime (here 16 years) costs of using the vehicles. The average annual costs are summed via contributions from the vehicle investment (exclusive the battery part of the drive train), the battery investment, maintenance costs, and the operation costs, which in this analysis is the annual average cost of fuelling or charging the vehicles to cover the annual driving distance. The annual driving distance is assumed the same for all vehicles, in a given year, despite the type of drive train.

### ICEV

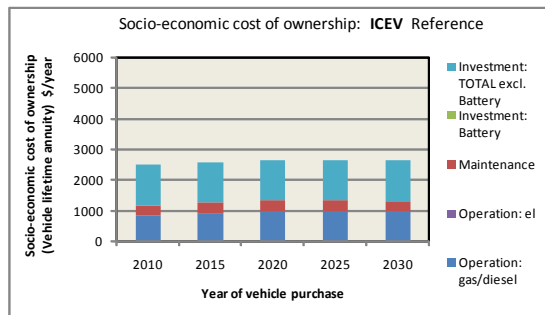

### HEV

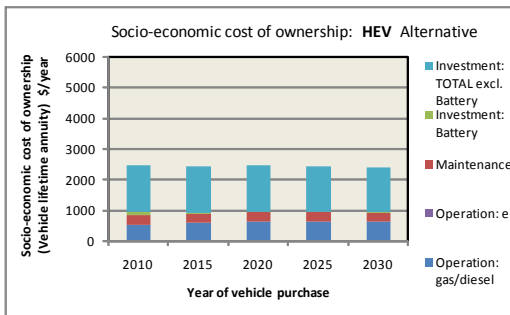

Figure 23 Socio-economic cost of ownership for the fuel based vehicles ICEV and HEV. [\$/year]

Annual costs of ownership for the fuel based vehicles ICEV and HEV are shown in Figure 23. The annual average costs for using these vehicles in any vintage bought in the period 2010-2030 are close to constant. Costs of ownership for a 2010 vintage vehicle are almost the same as for the future 2030 vintage vehicle. During the period, however, a small advantage builds up in favour of the HEV type of vehicle.

The HEVs have relatively high investments costs but are on the other hand considerable more energy efficient than the ICEV. Reduced operation costs make the HEV increasingly more cost effective relative to the conventional ICEV.

Close to 50% of the total cost of ownership for the 2030 ICEV relates to the operation (fuel costs) and maintenance costs. For the HEV this number is about 40%.

## Battery cost scenario: BatCost I:

### PHEV

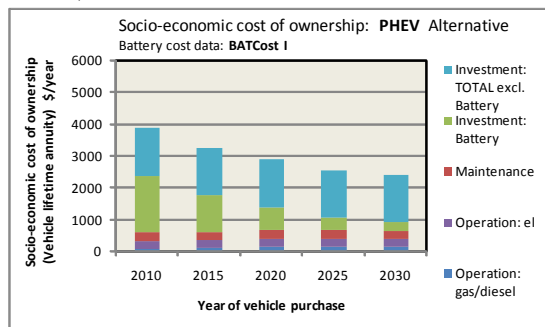

### BEV

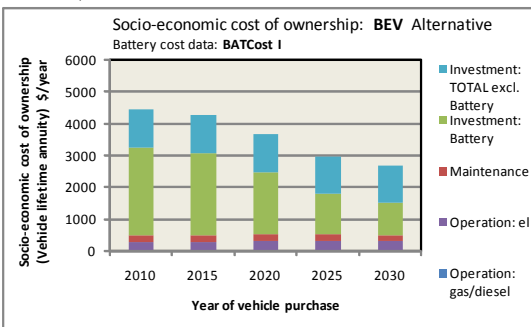

Figure 24 Socio-economic cost of ownership for the electricity based vehicles PHEV and BEV assuming the BatCost I scenario. [\$/year]

Relatively high investment costs for EV batteries constitute a disadvantage for the electricity based vehicles in the reference scenario. Battery pack costs, however, are assumed to drop gradually and year 2030 BEV and PHEV battery packs are expected to cost close to 200\$/kWh and 300\$/kWh respectively.

In contrast to the ICEV, costs of operation for the PHEV and BEV (electricity mainly) vehicles are very low. The annual socio-economic cost for using e.g. the BEV vehicle is about one third or less of the cost of using the future ICEV.

In 2030 only about 28% respectively 20% of the total costs are operation costs for the PHEV and BEV vehicles. Thus, having bought the EV vehicle the additional expenses for using it is expected to be relatively low and considerable lower than for using an ICEV.

## Ownership cost: DOE (2010) Recovery Act Battery cost assumptions

### Battery cost scenario: BatCost II:

According to the BatCost II scenario battery costs are expected to drop considerable already within about 5 years (cf. Figure 18 *Battery cost scenarios assumed for both PHEV and BEV vehicles.*

The assumptions make EV's cost competitive to the ICEV and HEV already from about year 2015.

#### **PHEV:**

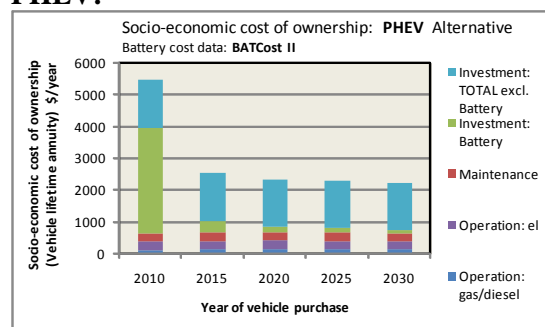

#### **BEV:**

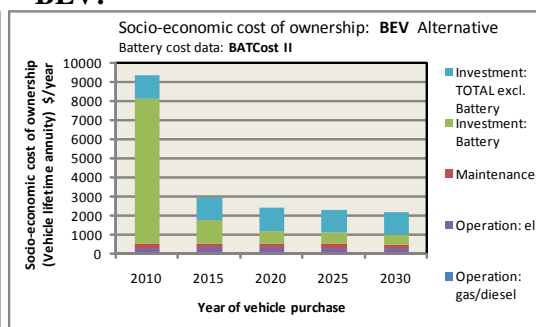

Figure 25 Socio-economic costs of ownership for the electricity based vehicles PHEV and BEV assuming the BatCost II scenario. [\$/year]

Comparing Figure 25 to Figure 24 illustrates the pronounced drop in battery costs expected. For the PHEV and BEV the investment cost still dominates ownership costs but very low costs of operation and maintenance make these vehicles attractive from 2015 and onwards.

## Relative cost of ownership: BEV, PHEV and HEV relative to ICEV

### Battery cost scenario: Comparing BatCost I and BatCost II

In scenario BatCost I the relative cost of ownership for the electricity based vehicles, PHEV and BEV, are considerable higher than the conventional ICEV until late in the period, as seen from Figure 26 A. The HEV is slightly cheaper than the ICEV falling to about 10% below the ICEV in 2030.

By the end of the period, year 2030, the BEV and in particular the PHEV costs are reduced considerable. By then the BEV is break-even with the ICEV. And the PHEV has ownership costs below the ICEV and on a level with the HEV.

### A: BatCost I

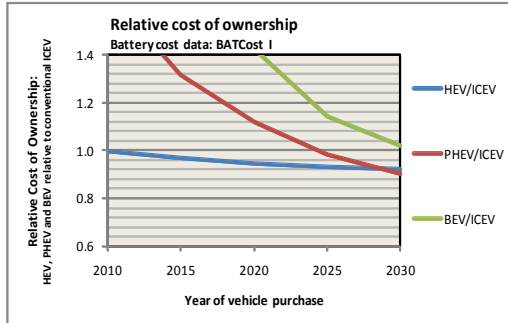

### B: BatCost II

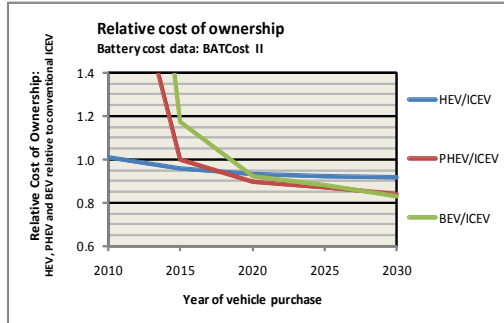

Figure 26 Relative cost ownership. **A:** Battery cost data: BATCost I scenario. **B:** Relative cost ownership. Battery cost data: BATCost II scenario.

Figure 26 illustrates the fast reduction in EV ownership costs in scenario BatCost II. Year 2015 the PHEV is expected to be break-even with the ICEV of vintage 2015. And from about 2020 and beyond the PHEV and BEV have vehicle lifetime costs below the HEV of same vintage. The BEVs become attractive getting annual socio-economic costs of ownership about 10%-17% below the ICEV from 2020-2030 in the BatCost II scenario.

### Ownership cost: CO<sub>2</sub> emission impact

What is the order of magnitude of costs assigned to CO<sub>2</sub> reduction going from the conventional ICEV to the alternative electricity based EV vehicles?

For answering this question the starting point is taken in the projected CO<sub>2</sub> emission allowance cost shown in Figure 27. CO<sub>2</sub> emission allowance cost are expected to increase from about 17\$/ton in 2010 to of about 50\$ per ton CO<sub>2</sub> emitted in year 2030.

Danish Energy Authority (DEA), April 2010.

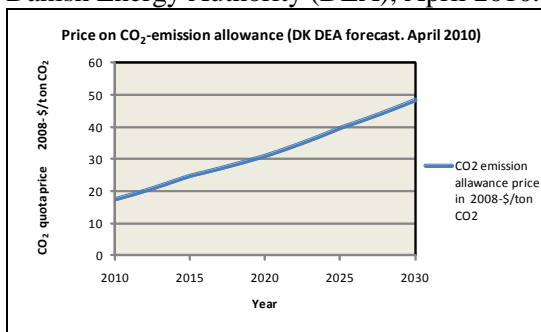

Figure 27 Cost of CO<sub>2</sub> emission allowance. Source: Danish Energy Authority (DEA), April 2010.

## Relative cost of ownership, including CO<sub>2</sub>Case I and II reduction

Adding costs for the CO<sub>2</sub> emission in accordance with Figure 27 (thus assuming that these costs are not reflected in the fuel and electricity costs used) we may calculate the cost of ownership in the two situations for the power system development (as described in paragraph 3.3 Assumptions on vehicle CO<sub>2</sub> emission) .

The relative costs of ownership only change slightly (almost unnoticeable) as consequence of adding the CO<sub>2</sub> emission costs. According to Figure 28 and comparing CO<sub>2</sub>Case I & II only very small differences occur 2030.

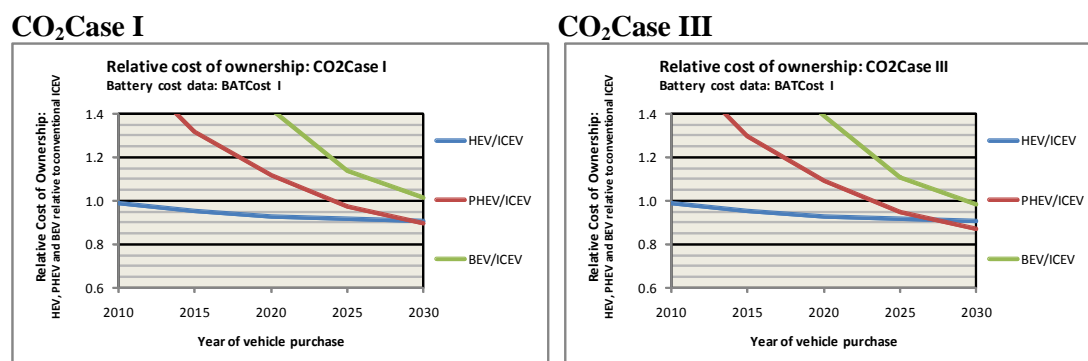

Figure 28 Relative cost of vehicle ownership, including value of CO<sub>2</sub> reduction in cases CO<sub>2</sub>Case I and CO<sub>2</sub>Case III.

Figure 28 may be compared to Figure 26 as well, showing cost of ownership excluding CO<sub>2</sub>-costs. And likewise, only minor differences are noticeable year 2030.

As conclusion, for the owner of a vehicle CO<sub>2</sub> emission cost have almost insignificant impact on the annual average costs of ownership. Thus, the economic effect of this parameter does not create an important economic incentive for the owner.

---

### An example:

The ICEV:

An ICEV year 2030 emits about 2.5 ton CO<sub>2</sub> per year assuming typical annual driving distance. Assuming 50\$/ton CO<sub>2eq</sub> year 2030 this amounts to an annual emission costs of 125\$/year. That amounts to about 5% of the annual socio-economic costs of vehicle ownership. A doubling of the costs to say 100\$/ton CO<sub>2eq</sub> imply emission costs approaching 10% of the total costs of vehicle ownership. For the conventional ICEV the annual maintenance costs and the cost of fuel adds to about half of the total costs of ownership. CO<sub>2</sub> emission costs may then amount to about 20% of the costs of driving (operating) the vehicle.

The BEV:

The BEV in 2030 may emit only about 1/5 or less of the CO<sub>2</sub> compared to the ICEV, assuming the CO<sub>2</sub>case III power system development (implying a CO<sub>2</sub> decent to zero in 2050). This reduction for the BEV is mainly due to the power system development as seen from Figure 17.

For the BEV in the fleet 2030 the emission is about or less than 0.5 ton CO<sub>2</sub> per year. Costs hereof corresponds to less than 1% of the total costs ownership assuming 50\$/ton CO<sub>2eq</sub>.

Rising to less than 2% when assuming 100\$/ton CO<sub>2eq</sub> year 2030. However, the annual electricity plus maintenance costs for the BEV only amount to about 15-20% of the total costs of ownership. Therefore CO<sub>2</sub> emission costs relative to the costs of using/driving the vehicle (operation costs) increase to being somewhat less than 5% respectively 10%.

The difference:

In 2030 the emission difference between the ICEV and the BEV is about 2 ton CO<sub>2</sub> per year. This corresponds to an annual cost difference in favor of the BEV of about 100\$/year assuming 50\$/ton CO<sub>2eq</sub> year 2030. And of about or above 200\$/year assuming 100\$/ton CO<sub>2eq</sub> emitted.

---



## Ownership costs: Impact of electricity and fuel prices

The socio-economic fuel and electricity price developments assumed as reference are based on forecasts published by the Danish Energy Authority, April 2010 (DEA, April 2010). We will refer to this reference as:

- FuelCost I & ElCost I: Forecast via DEA, April 2010.

As sensitivity analyses, calculations are furthermore carried out based on alternative developments for energy prices, where fuel and electricity prices are assumed to change in concert. Prices of gasoline/diesel and electricity are assumed linked via common percentage changes. (Prices year 2010 are assumed fixed but from then a linear %-increase is assumed, lifting the year 2010 prices 0%, the 2020 prices +10 and 2030 prices with + 20 %. Likewise towards -20% in 2030 as illustrated in Figure 29.) These alternative developments will be termed:

- FuelCost II & ElCost II: Forecast via DEA, April 2010 but up-scaled via linear %-increase:  
Up +0% in 2010 - to up +20% in 2030.
- FuelCost III & ElCost III: Forecast via DEA, April 2010 but down-scaled via linear %-decrease:  
Down -0% in 2010 - to down -20% in 2030.

These scenario assumptions are shown in Figure 29.

### FuelCost I, II and III

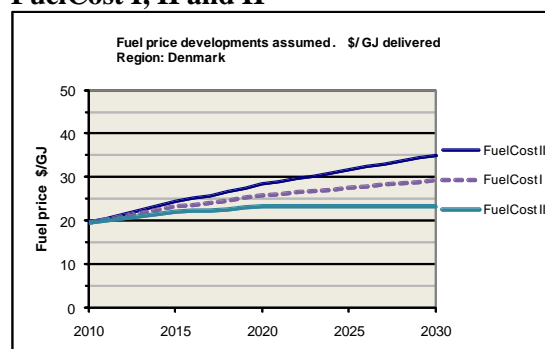

### ElCost I, II and III

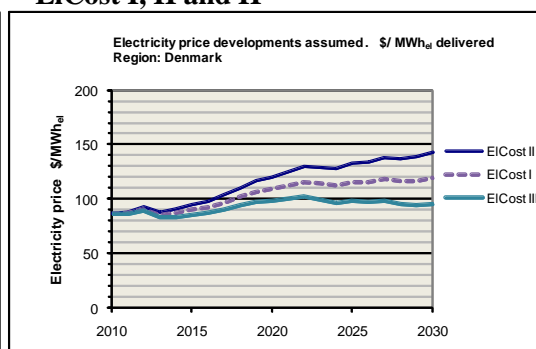
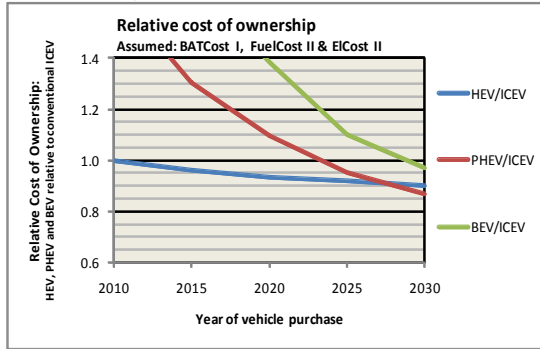

Figure 29 Energy price developments assumed for fuel (gasoline/diesel) and electricity.

Total ownership costs are calculated on this basis. Assuming gasoline/diesel and electricity prices developing according to scenarios FuelCost II&III and ElCost II&III the relative cost of ownership for the ICEV, HEV, PHEV and BEV changes as illustrated in Figure 30.

On this basis results change towards earlier respective later occurrence of EV-ICEV break-even. In high energy cost case II this is in preference for the electricity based vehicles PHEV and BEV. And the opposite is seen in energy cost case III, as expected.

**BatCost I, FuelCost II & ElCost II**



**BatCost II, FuelCost II & ElCost II**

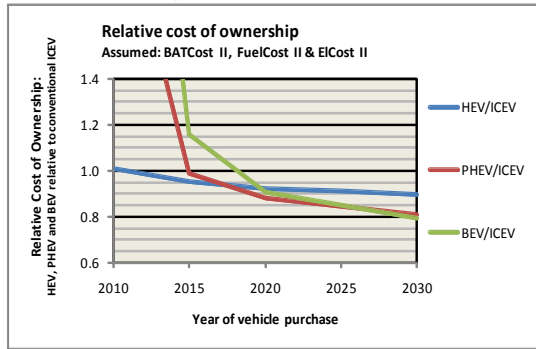

**BatCost I, FuelCost III & ElCost III**

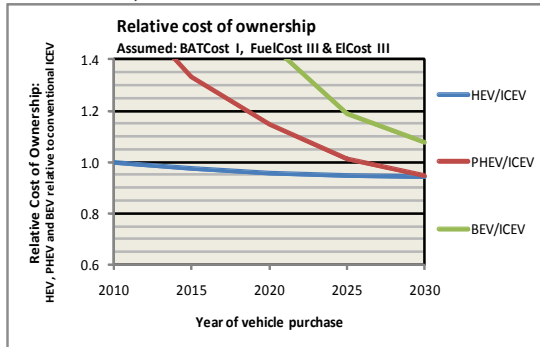

**BatCost II, FuelCost III & ElCost III**

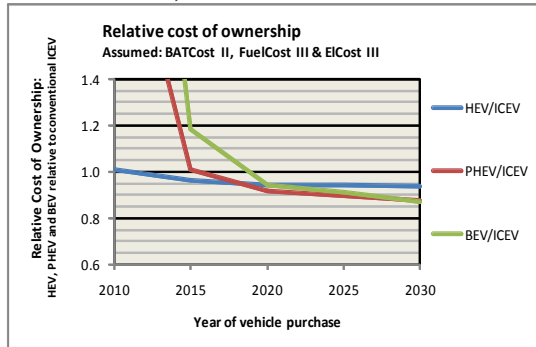

Figure 30 Relative cost ownership. Battery cost data: BATCost I and BATCost II. Energy price data: (FuelCost II & ElCost II) and (FuelCost III & ElCost III).

Generally the electricity based vehicles will have an advantage relative to the fuel based vehicles in a situation where the general costs of fuel and electricity increase above the reference, as seen from Figure 30. Looking at the composition of the overall costs of ownership of the vehicle types, the annual costs for fuel (or propellants) for the ICEV and HEV weights considerable more to the ownership costs than is the case for the electricity based vehicles. This is seen comparing Figure 23 and Figure 24.

In case FuelCost II+ElCost II and assuming the reference battery price development, BATCost I, it is seen that costs of ownership for the PHEV becomes break even with the ICEV in the period 2020-2025. That is, a few years earlier than in the reference development. For BEVs the year for break-even with the ICEV is shortened of about 2 years. As it can be seen comparing Figure 26 and Figure 30.

Going to scenario FuelCost III+ElCost III (case -20% in 2030) this tendency is reversed.

In BATCost II, the relatively low cost battery case (DOE data), and assuming high energy cost scenario, i.e. FuelCost II+ElCost II, both the PHEV and BEV show ownership costs of about 20% below the ICEV lifetime ownership costs for vintage 2030 vehicles. In the low energy cost scenario, FuelCost III+ElCost III, this PHEV and BEV advantage is reduced to about 10% lower ownership costs for the vintage 2030 vehicles.

### 3.6 Conclusion on individual EVs

From the data adopted for the analysis the following observations and main results may be drawn forward:

#### Energy:

- Electricity substitutes gasoline/diesel via the EV. EV drive trains have potential for being very energy efficient.
- Via EVs segments of the transport sector can diversify its energy resource base and reduce dependency on oil based fuels.
- 3000 kWh electricity may sustain about 20.000 km average vehicle EV driving. About 10000 kWh of gasoline/diesel is required via the corresponding conventional ICEV.

#### CO<sub>2</sub> emission:

- EV CO<sub>2</sub> emission relates to the power supply charging the vehicles. The CO<sub>2</sub> footprint of the individual EV changes in time in accordance with the power supply.
- According to the Danish 'reference' development for the *marginal* power supply EVs bring insignificant CO<sub>2</sub> reduction (due to *coal dominated marginal* power production).  
However, assuming *average power supply characteristics*, and linear descend to zero CO<sub>2</sub> emission in 2050 for the power supply, substantial CO<sub>2</sub> reduction is achieved via EVs substituting ICEVs. Ultimately EVs may provide zero CO<sub>2</sub> emission road transport.
- The individual ICEV of today may emit about 2-3 ton CO<sub>2</sub> /year. This equals maximal achievable EV CO<sub>2</sub> reduction.

#### Economy:

- Cost and lifetime of EV batteries much determine the EV economy. This based on the socio-economic cost of ownership.
- In a 'conservative scenario' (ref. COWI 2007) on battery cost development PHEVs may get break-even with the ICEV beyond year 2020.
- In an 'optimistic scenario' (ref. USDOE 2010) on battery cost development PHEVs may get break-even with the ICEV year 2015.
- CO<sub>2</sub> emission allowance costs of 2-3 ton CO<sub>2</sub> are small relative to the overall costs of vehicle ownership. And may not constitute an incentive for the vehicle purchase.

#### Socio-economic costs of vehicle ownership:

Approach and assumptions made.

##### 1) Monetized issues taken into account:

- Investment costs
- Maintenance cost
- Annual costs of operation (fuel, electricity)

##### 2) Issues *not* taken into account:

- Infrastructure costs
- Insurance costs
- Power system flexibility gains (regulation capability, postpone investments in peak production/grid capacity etc.)

##### 3) Externalities *not* taken into account:

- Reduced local pollution

- Opportunities for industry and future employment ('first mover' effects)
- Oil substitution (reduced reliance on oil)
- EVs hedging for increasing oil prices (and rising transport costs).
- System robustness. Security of energy supply (diversified transport energy basis)

Most of the externalities *not* taken into account tend to act in favor of the EV alternatives. Infrastructure costs for EV alternatives relative to the ICEV reference cost are not addressed in the present analysis.

## 4 EV and road transport sector scenarios

### 4.1 EV scenario aims

In this chapter road transport fleet scenarios are set up covering potential future deployment of electric vehicles. The present chapter considers the development of EV fleets based on assumptions on annual market shares for electric vehicles. Characteristics of the EV fleets and what they substitute are derived from EV and ICEV development assumptions described in the previous chapter 3. The EV scenarios form basis for analyses on:

- Road transport sector consequences of potential EV fleet development.  
Marginal analyses: Transport sector – power system interaction not included.  
(The subject for this chapter)
- Road transport sector – power system interaction via EV fleet development.  
Integrated analyses: Transport sector – power system interaction included in power system models (Balmorel & Wilmar). (Presented in chapters to follow)

It is the aim to develop (ambitious but plausible EV deployment) scenarios for electricity based road transport that may challenge the overall power system in order to identify potential system constraints, benefits and barriers for an EV-implementation.

For the integrated analyses it is furthermore an aim to quantify potential effects of the EV flexibility (as to when to charge from or discharge to the grid, V2G). A hypothesis being, that the EV flexibility and the EV potential to contribute actively to power regulation increase the ability of the overall system to integrate fluctuating power generation, e.g. such as wind power.

The marginal analyses (presented in the present chapter) focus on energy substitution, CO<sub>2</sub> emission reduction potentials and marginal/partial socio-economic consequences of the set up EV scenarios. Analyses address the ability of the EV scenarios to meet overall political aims on energy use and economy, CO<sub>2</sub> emission and security of energy supplies. Sensitivity analyses are included to illustrate the space of consequences when changing important scenario assumptions and framework conditions.

### EV market projections and scenario analysis

Forecasting the EV market developments 10 or 20 years ahead is very uncertain. A vast number of factors may impact the future road transport fleets and EV markets. Such factors are e.g. the technical options and their costs, alternatives to alternatives, breakthrough potentials, transport policies and the overall economy, trends etc. And most such factors are highly uncertain.

Table 1 of Appendix 1 shows an incomplete overview, per ultimo 2010, of some published expectations to the EV market. Motor companies, battery manufacturers, marketing and consulting firms, research institutions, power companies etc. and governments are listed and quoted in short. The table indicates a shared conviction: The EV market has emerged and develops rapidly. It may presumably continue growing fast throughout and beyond this

decade. Many expect very large market shares for EVs, battery only EVs (BEVs) and plug-in hybrid EVs (PHEVs), at some point in future.

Despite uncertainties energy planning must scan potential future developments, to identify desired developments and hedge for the undesired. 'Exact'/detailed long term forecasts may be less important in such context. More important may be a process of 'if-then' analyses to enlighten a space of options and their consequences. Scenario analysis is a tool in these situations.

### **Market share assumptions**

Scenarios for EV integration (PHEV and BEV) as alternatives to the conventional ICEV in the Danish road transport segment, Passenger Cars + LCV < 3.5t, are derived applying the market share forecasts developed by EPRI in 2007 [91]. These market share scenarios are described in EPRI report nr. 1015326, covering potential market share developments for PHEVs. The long term EPRI forecasts have time horizon year 2050. For the present analysis the EPRI Medium PHEV Scenario market share projection up to year 2030 is used. This scenario forms the basis for setting up corresponding scenarios for PHEV and BEV deployment in a Danish and European context. Relative market shares for the BEV and PHEV vehicles are furthermore based on the IEA Blue Map scenario from 2009 [92].

### **Approach**

The level of description applied for the long term development of the Danish road transport segment is somewhat rude. Our scope may allow this. Our focus is mainly the overall system consequences of a potential very radical or fast EV development and deployment in the Danish and European transport and energy systems.

The alternative EV vehicles (PHEVs and BEVs) are assumed to substitute conventional (reference) vehicles (ICEVs) that otherwise (in 'business as usual') during the period would be expected to enter this fleet segment. Close to fleet average vehicle characteristics are assumed for both the reference and the alternative vehicles, as to maintain consistency for comparison. All vehicles are assumed to supply corresponding transport service seen from a consumer perspective. (E.g. a limited range BEV is assumed to substitute ICEV of similar limited range application patterns.)

The analysis focuses on the changes only, going from the reference development to the alternatives. This is the case for the marginal analyses and for the detailed overall analyses of the combined transport and power system linked through the EVs (described in following chapters).

## 4.2 Danish stock of Passenger Cars + LCVs.

Assuming the vehicle life distribution fixed, in accordance with recent statistics, and the overall fleet size developing according to the DTF Forecast 2007 [41], the renewal of the Danish fleet is expected to develop as illustrated in Figure 31. The average lifetime is about 17 years for vehicles in this Danish fleet segment covering Passenger Cars + LCV<3.5t (Figure 32).

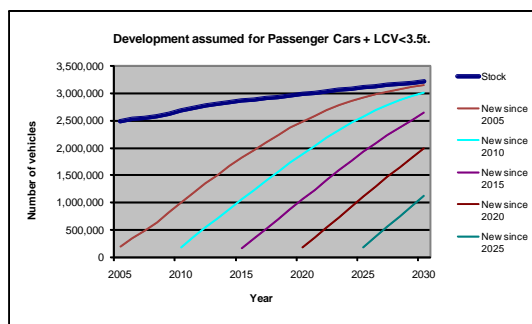

Figure 31 Development assumed for the Danish stock of Passenger Cars + LCV < 3.5t. Diagonal lines describe the accumulated number of new vehicles entering the fleet. Based on DTF Forecast 2007 [41].

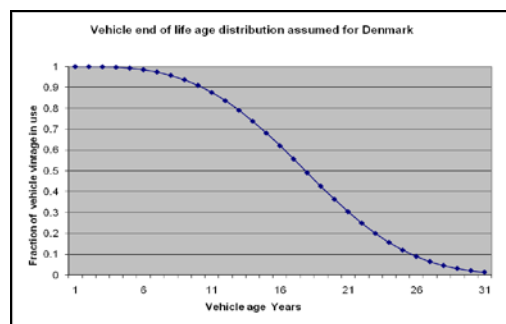

Figure 32 End of life distribution for vehicles in the Danish fleet assumed for the scenario analysis. Covering Passenger Cars + LCV < 3.5t. (Average lifetime: 17 years.). [46]

Focussing e.g. on year 2010 it is seen from Figure 31 that about 1.000.000 vehicles have entered the fleet since year 2005. Focussing on year 2015, the figure shows that about 2.000.000 vehicles have entered the fleet since 2005.

As mentioned above, the (historic) vehicle lifetime distribution for the Danish fleet has been assumed for the presented scenarios. Thus, few of the new vehicles entering the fleet say 2015 will still be present in the 2030 fleet, carrying 2015 technology characteristics.

## 4.3 Scenario overview

### PHEV & BEV substitute ICEV (marginal analysis)

The presented scenarios focus on the Danish road transport sector. And specifically on the aggregation of the fleet segments: Passenger Cars+LCV<3.5t. Of about 2/3 of the total road transport *energy consumption* is within these segments.

*The reference scenario:* ICEV ‘Business as usual’

- ICEV, the conventional vehicle, being substituted by alternatives: (Chapter 4.5)
  - Period: 2010-2030Basic references:
  - Fleet development according to: DTF, Forecast 2007 [41].
  - Energy price development: Danish Energy Authority (DEA).  
Baseline forecast from April 2010.

*Alternative scenarios:*

- PHEV substituting ICEV: PHEV (Chapter 4.5)
  - Period: 2010-2030Basic references:
  - Market share development according to EPRI (2007) [42]
  - Energy price development: Danish Energy Authority (DEA).  
Baseline forecast from April 2010.
  - CO<sub>2</sub> emission per kWh electricity: Baseline forecast from DEA April 2010 and DEA April 2011.
- BEV substituting ICEV: BEV (Chapter 4.7)
  - Period: 2010-2030Basic references:
  - BEV market share development relative to the PHEV according to IEA 2009 (Blue Map scenario 2010-2030) [43]. PHEV market share development according to EPRI (2007). [xx]
  - Energy price development: Danish Energy Authority (DEA).  
Baseline forecast from April 2010.
  - CO<sub>2</sub> emission per kWh electricity: Baseline forecast from April 2010 and DEA April 2011.

*Sensitivity analyses:*

- Development for CO<sub>2</sub>-emission per kWh electricity:  
Reference development: Danish Energy Authority. Forecast April 2011.  
Relative to reference:
  - Linear decrease in period 2010-2030: From level year 2010 to zero in year 2050.
- Energy price development:  
Reference development: Danish Energy Authority. Forecast April 2010.  
Relative to reference:
  - Linear %-increase in period 2010-2030: +0% in 2010 to +20% in 2030
  - Linear %-decrease in period 2010-2030: -0% in 2010 to -20% in 2030
- Battery cost development in \$/kWh in period 2010-2030:
  - Reference development assumed according to references (COWI 2007). [31]



- Battery price development according to DOE: Recovery Act: Transforming America's Transportation Sector. Batteries and Electric Vehicles. 14 July 2010.[35]

*Calculated costs relate to the particular year in question in scenarios. Costs shown include:*

- Investments costs for the scenario vehicles. Calculated as sum of annuities for each vehicle type and vintage included. The annuity is based on a depreciation period of 16 years.
- Maintenance costs for all vehicles in the scenario. Summed costs for the particular vehicle type and vintage.
- *Costs of vehicle operation for the particular year.* (The annual electricity and fuel costs relate to the particular year, and NOT to vehicle lifetime average costs as was assumed for the chapter 3 analyses.)

The socio-economic calculation is based on factor prices. Thus taxes, subsidies etc. are not included.

Infrastructure and insurance costs are not included. It is emphasized that costs covering infrastructure needs, infrastructure build up and substitution issues are not included in the present marginal/partial socio-economic analysis.

### **Externalities not included**

As for the Chapter 3 analyses, it must be emphasized that so-called externalities, costs issues experienced by society by large but not reflected in marked prices, are not taken into account in the present analysis. Examples of external cost or benefit issues are:

- Reduced dependence on fossil based fuels for transport (gasoline/diesel) as consequence of the scenario.
- Effects on security of energy supply as consequence of the scenario due to diversification of the transport energy supply basis.
- CO<sub>2</sub> reduction options for electricity based transport. This in accordance with options and aims for the overall power supply system.
- Demand side flexibility in the overall power system due to (G2V flexible charging) demand growth for road transport. (Potential for mobilizing increased regulation capability and generation support in the overall power system.)
- EV fleet potential for IT organized load leveling, peak-shaving and peak power supply via vehicle to grid (V2G discharging) ability, as consequence of the scenario. (Potential for increasing regulation capability and support in the overall power system.)
- Local environmental benefits as consequence of the scenario including traffic noise reduction.

Costs related to such issues are very difficult to quantify (and monetize). Consequently, externalities are often not taken into account, which is the case also in the present analysis. Nevertheless these issues constitute firm cost elements for society at large. When evaluating the marginal/partial socio-economic results in the present analysis, external effects as consequence of the scenario (positive and negative) should be added, to reach consequences applying for society at large.

Some of the above issues will be in focus in the following chapters of this report. These issues relate to the potential interaction between the transport sector and the power sector and power regulation issues as consequence of potential enhanced overall system flexibility.

## 4.4 PHEV Scenario: Energy and CO2

### PHEV scenario: Fleet development

The EPRI Medium PHEV Scenario is replicated in Figure 33 A below. Market shares for PHEVs, starting low year 2011, is assumed to grow fast in the period 2015-2025 and reaches a market share close to 50% in 2025. As consequence almost 40% of the vehicles on the road year 2030 in this fleet segment are PHEVs.

Figure 33 (PHEV B) shows the corresponding number of alternative PHEV vehicles on Danish roads following the EPRI market share scenario. The number of PHEVs in this scenario reaches about 1.110.000 PHEV vehicles year 2030.

#### A: PHEV market share

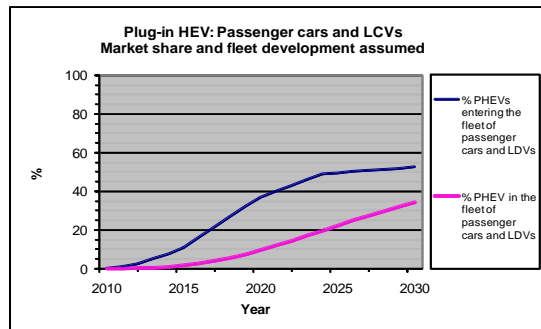

#### B: PHEV fleet size

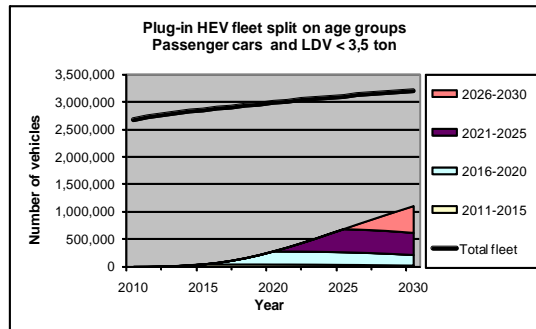

Figure 33 A: Assumed market share for plug-In hybrid electric vehicles (PHEV). B: Number of vehicles in the Danish fleet and age group composition in Scenario A2T\* for plug-In hybrid electric vehicles (PHEV) for category Passenger Cars+LCV<3.5t. Source on market share development: EPRI Report 1015326 Environmental Assessment of Plug-In Hybrid Electric Vehicles. Volume 1: Medium PHEV scenario, July 2007.[42]

### PHEV scenario: Energy substitution

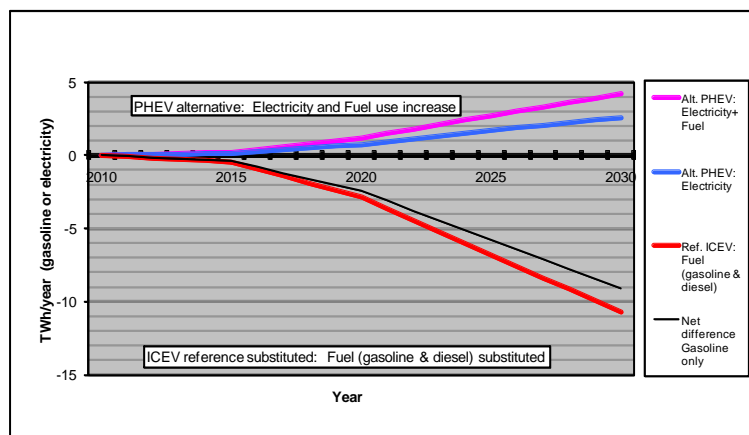

Figure 34 Transport energy use in PHEV scenario. (The PHEV alternative fuel and electricity use expressed in numbers > 0. Reference ICEV fuel substituted expressed in numbers < 0.) [TWh/year]

Fuel (gasoline and diesel) substituted in the PHEV scenario in year 2030 equals about 9.0 TWh<sub>fuel</sub> /year. ICEVs substituted in 2030 reduce fuel consumption of about 11 TWh<sub>fuel</sub>, and the alternative PHEVs are expected to consume about 2 TWh<sub>oil</sub> in year 2030.

The corresponding increase in electricity consumption year 2030 for operating the PHEV fleet amounts to 2.5 TWh<sub>electricity</sub>.

The numbers reflect a substantial substitution of oil based fuels at the expense of a rather moderate increase in electricity consumption. One kWh of electricity used by PHEVs substitutes about 3-4 kWhs of fuel otherwise used by ICEVs year 2030, according to the PHEV scenario fleet composition year 2030.

### PHEV scenario: CO<sub>2</sub> emission

The analysis is split into two cases for the CO<sub>2</sub> emission related to electricity consumed in the Danish system. These are termed:

- **CO<sub>2</sub>Case I:** The *marginal* specific CO<sub>2</sub> emission per kWh electricity is almost constant over time. The power system develops according to forecast from The Danish Energy Authority (DEA, April 2010) [32]
- **CO<sub>2</sub>Case III:** The *average* specific CO<sub>2</sub> emission per kWh develops from characteristics of today's power system assuming a gradual linear phasing out to zero of all fossil fuels used in the system year 2050.

More details on these assumptions are described paragraph 3.3.

### PHEV scenario: CO<sub>2</sub>CaseI emission

#### CO<sub>2</sub>CaseI: Marginal reference emission

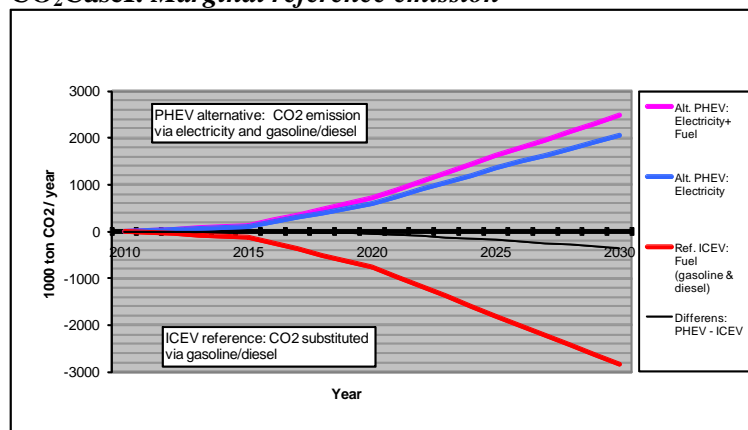

Figure 35 CO<sub>2</sub>-emission in PHEV scenario assuming CO<sub>2</sub> Case I. [1000 ton CO<sub>2</sub> /year]

Assuming CO<sub>2</sub> Case I, which implies the *marginal* and almost constant specific CO<sub>2</sub> emission per kWh electricity during the period, only minor CO<sub>2</sub> reductions are achieved in the PHEV scenario, substituting the ICEV with PHEVs in the Danish system. About 0.2 million ton CO<sub>2</sub> reduced emission is achieved in 2030.

The *marginal* power supply system CO<sub>2</sub> characteristics inherited by the PHEV maintain CO<sub>2</sub> emissions at about the same level as the ICEV of equal vintages during period.

Assuming CO<sub>2</sub> Case III, which assumes *average* power supply system CO<sub>2</sub> characteristics, and which furthermore assumes a linear descent to zero CO<sub>2</sub>-emissions by 2050, CO<sub>2</sub> reductions are pronounced in the PHEV scenario. About 1.8 million ton CO<sub>2</sub> emission reduction is achieved in 2030. And as the power system develops towards lower emissions the existing PHEV fleet follows.

**CO<sub>2</sub>Case III: Descending average emission**

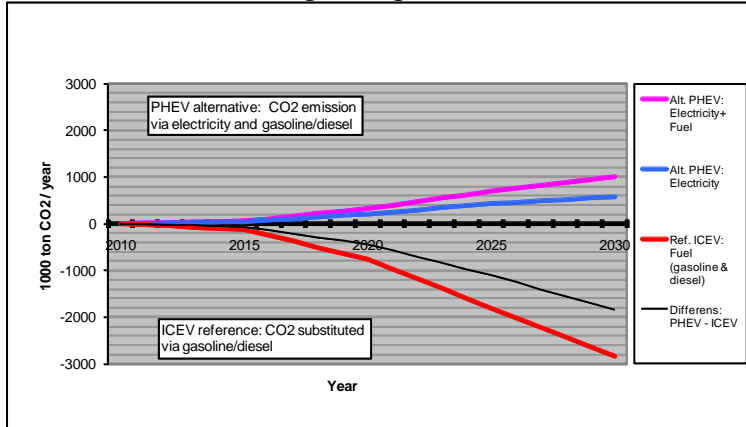

Figure 36 CO<sub>2</sub> emission in PHEV scenario assuming CO<sub>2</sub> Case III. [1000 ton CO<sub>2</sub>/year]

#### 4.5 PHEV-scenario: Socio-economic costs (marginal analysis)

The socio-economic costs calculated are so-called marginal costs. It is assumed that the transport scenario only ‘marginally’ interacts with the overall energy system. Thus the transport scenarios do not influence electricity prices and fuel prices. This evidently is a very crude assumption. In later chapters which include modelling of transport segments interacting with the overall power this limitation is not present.

The calculated socio-economic costs for scenarios are composed of:

- Investment costs. Shown as the annual costs since purchase when financed via loans with time of depreciation of 16 years.
- Maintenance costs for the year in question.
- Costs of propellants (electricity and fuel costs). Costs related to the annual driving (km/year) for the year in question.

External costs are not included.

#### PHEV Scenario: BatCost I

##### Reference energy price assumptions

Figure 37 shows overall socio-economic costs for the PHEV scenario broken down into components of:

- Alternative:  
PHEV cost for propellants (Electricity and fuel) and PHEV annual investment and maintenance costs.
- Reference:  
ICEV costs for fuel and ICEV annual investment and maintenance costs, and
- Difference:  
Overall scenario socio-economic costs (Difference= Alternative – Reference) for each year in the period 2010-2030.

#### A: BatCost I & Fuelcost I & Elcost I

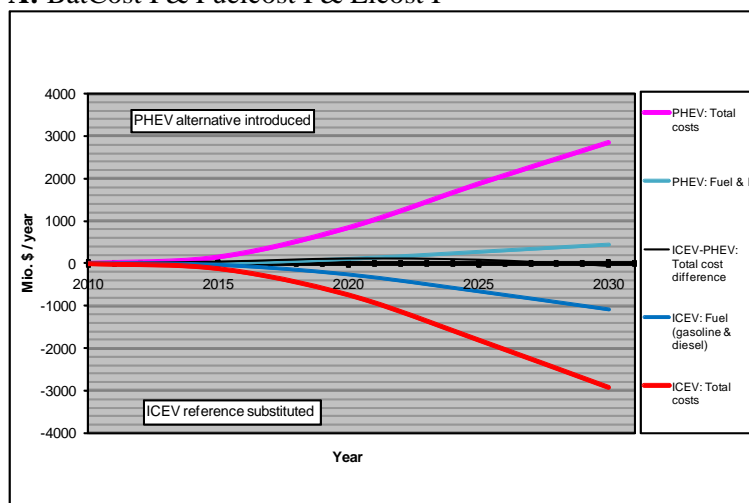

Figure 37 PHEV scenario: Socio-economic costs based on: Reference assumptions via BatCost I, Fuelcost I & Elcost I. (PHEV scenario costs (alternative) are expressed in numbers >0. ICEV reference costs are expressed in numbers < 0.) [Mio.\$/year]

It is seen from Figure 37 that costs are almost equal for the alternative PHEV scenario and for the corresponding reference (ICEV) scenario development. Details show that annual deficits rise to about 100 Mio.\$/year in year 2020, and descends from then. Annual gains emerge from about year 2027 reaching a gain of about 50 Mio.\$/year in year 2030.

**PHEV Scenario: Energy price sensitivity**

**Energy price: Linear increase to +20% in 2030**

**B: BatCost I & Fuelcost II & Elcost II**

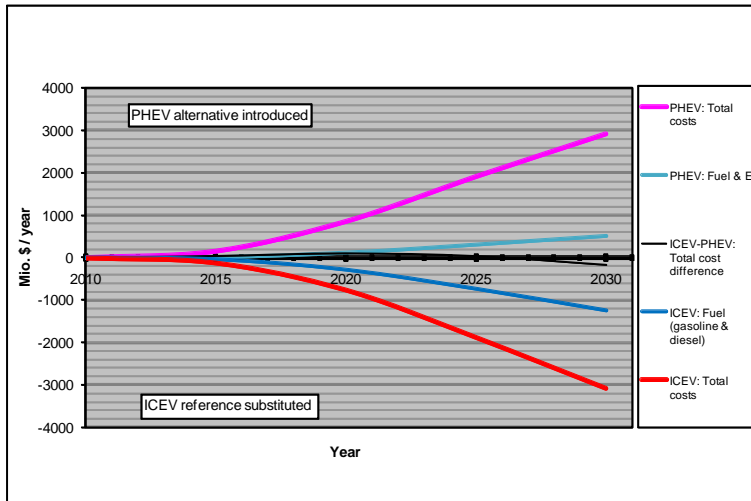

Figure 38 PHEV scenario socio-economic costs assuming: **Fuelcost II & Elcost II (Linear increase to +20% in 2030)** and BatCost I. [Mio.\$/year]

**Energy price: Linear decrease to -20% in 2030**

**C: BatCost I & Fuelcost III & Elcost III**

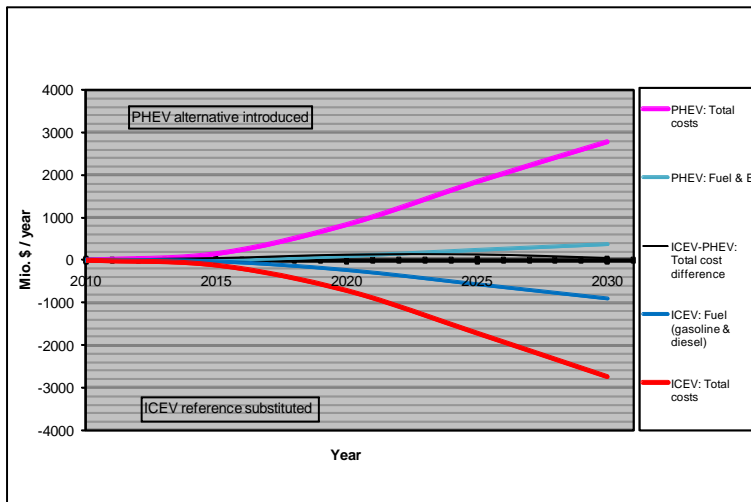

Figure 39 PHEV scenario socio-economic costs assuming: **Fuelcost III & Elcost III (Linear decrease to -20% in 2030)** and BatCost I. [Mio.\$/year]

Figure 38 and Figure 39 illustrate the advantage/disadvantage of the electricity based PHEV vehicles in cases of general rising/stagnating energy prices on both electricity and transport fuels. The relative advantage of these vehicles is due to relatively lower operating costs. Although higher investment costs, the PHEV scenario in 2030 shows gain of about 200

Mio.\$/year in the rising energy cost situation. In the descending energy cost case the PHEV scenario reaches break-even to the 'business as usual' ICEV reference development year 2030.

Comparing details on these results for year 2030 with Figure 37 for the reference energy price development gains in the PHEV scenario are seen to emerge a few years earlier in case of rising energy prices and equally a few years later in the descending energy price case.

### **PHEV Scenario: BatCost II**

#### **Reference energy price assumptions**

##### **A: BatCost II & Fuelcost I & Elcost I**

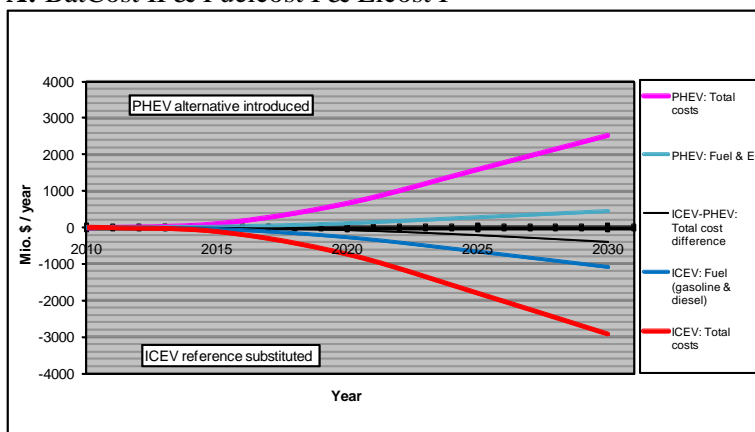

Figure 40 A: PHEV scenario socio-economic costs assuming: **BatCost II**, Fuelcost I & Elcost I. [Mio.\$/year]

Assuming battery costs and lifetime developing according to BatCost II assumptions (Ref.: US DOE Recovery Act, 2010) the PHEV vehicle scenario shows socio-economic gains already from year 2015.

In year 2030 the PHEV scenario shows an annual surplus of about 400 Mio.\$/year (Figure 40).



## 4.6 BEV Scenario: Energy and CO2

### BEV scenario: Fleet development

The EPRI Medium PHEV market share assumptions from 2007 [42], and IEA, Blue Map Scenario (2009) [43] assumption on the relative market share for BEV relative to PHEV form basis for the BEV fleet scenario developed. Market shares for BEVs, start low year 2011, and grow to a market shares close to 25% in 2025. As consequence almost 20% of Danish vehicles are BEVs year 2030 in this fleet segment.

**A: BEV market share**

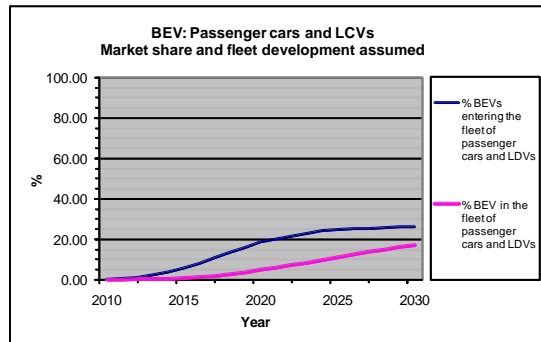

**B: BEV fleet size**

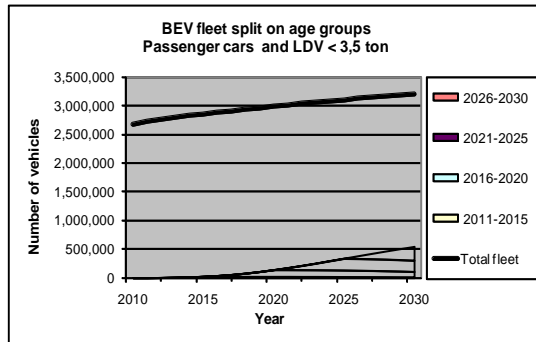

Figure 41 **A:** Assumed market share for battery electric vehicles (BEV) for category Passenger Cars+LCV<3.5t. **B:** Number of vehicles in the Danish fleet and age group composition in Scenario A2T\* for plug-In hybrid electric vehicles (BEV) in category Passenger Cars + LCV <3.5t.

### BEV scenario: Energy substitution

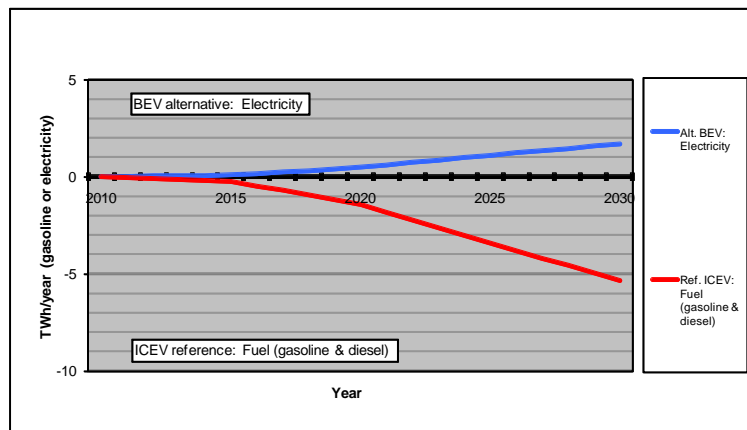

Figure 42 Transport energy use in BEV scenario. (The BEV alternative electricity use is expressed in numbers > 0. Reference ICEV fuel substituted expressed in numbers < 0.) [TWh/year]

According to Figure 42 BEVs year 2030 substitutes about 5.4 TWh<sub>fuel</sub>/year (gasoline/diesel) otherwise fueling ICEVs in the reference case. The BEV scenario fleet increases the electricity demand of about 1.7 TWh<sub>electricity</sub> year 2030.

## BEV scenario: CO<sub>2</sub> emission

The two CO<sub>2</sub> emission cases termed:

- **CO<sub>2</sub>Case I** (corresponding to *marginal* CO<sub>2</sub> characteristics for electricity consumed). Supplied by power system developing according to the resent forecast from The Danish Energy Authority (DEA, April 2010) and
- **CO<sub>2</sub>Case III** (corresponding to *average* CO<sub>2</sub> characteristics for electricity consumed). Supplied by power system developing from today's Danish configuration assuming a gradual linear phasing out to zero of all fossil fuels used in the system year 2050.

More details are described paragraph 3.3.

## BEV scenario: CO<sub>2</sub>CaseI emission

### CO<sub>2</sub>Case I:

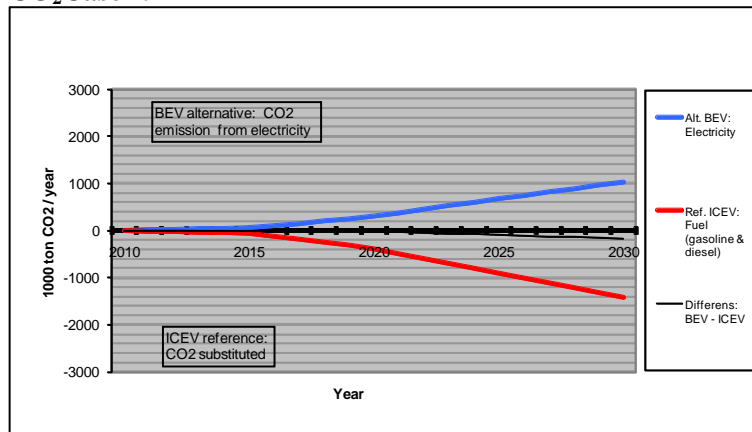

Figure 43 CO<sub>2</sub> emission in BEV scenario assuming CO<sub>2</sub> Case I. [1000 ton CO<sub>2</sub>/year]

In CO<sub>2</sub> case I, assuming *marginal* power supply, CO<sub>2</sub> reduction consequences of the BEV-scenario are minor. Late in the period a minor reduction emerges.

This is the combined effects of the differing drive trains for the two vehicle types, BEV and ICEV, and the specific CO<sub>2</sub> emission per kWh electricity consumed during the period.

### CO<sub>2</sub>Case III:

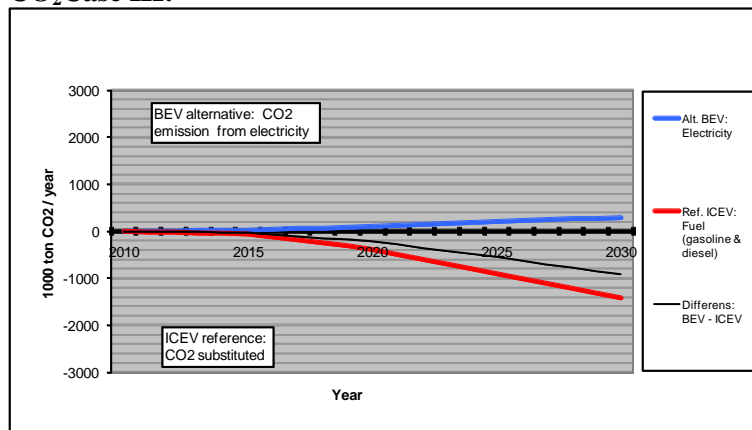

Figure 44 CO<sub>2</sub> emission in BEV scenario assuming CO<sub>2</sub> Case III. [1000 ton CO<sub>2</sub>/year]

CO<sub>2</sub> Case III assumptions favor the BEV scenario. About 0.9 million ton reduction in CO<sub>2</sub> emission is achieved in 2030. As the power system develops towards lower emission the existing BEV fleet benefits as seen comparing Figure 43 and Figure 44.

#### 4.7 BEV-scenario: Socio-economic costs (marginal)

##### BEV Scenario: BatCost I

##### Reference energy price assumptions:

##### A: BatCost I & Fuelcost I & Elcost I

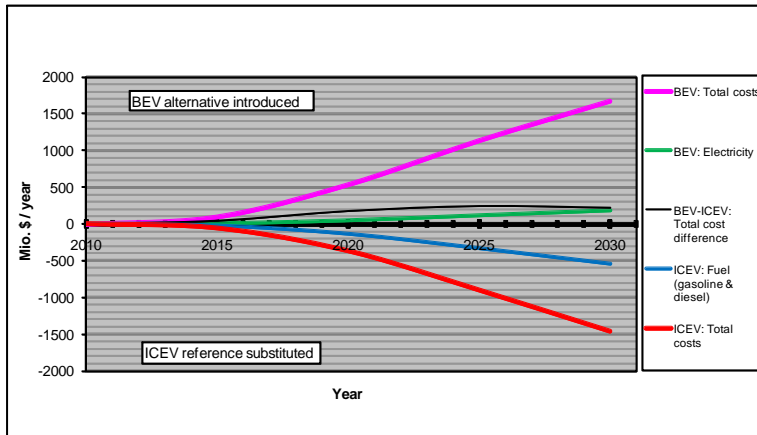

Figure 45 BEV scenario socio-economic costs assuming: BatCost I, Fuelcost I & Elcost I. Reference assumptions. (BEV scenario costs (alternative) are expressed in numbers >0. ICEV reference costs are expressed in numbers < 0.) [Mio.\$/year]

Figure 45 shows overall socio-economic costs for the BEV scenario broken down into components of:

- Alternative: BEV cost for propellants (Electricity) and BEV annual investment and maintenance costs,
- Reference: ICEV costs for fuel and ICEV annual investment and maintenance costs, and
- Overall scenario socio-economic costs (Difference= Alternative – Reference) for each year in the period 2010-2030.

It is seen from Figure 45 that the socioeconomic transport costs increase in the alternative, the BEV scenario, relative to the corresponding reference (ICEV) scenario development. Year 2025 the annual deficits rises to well 200 Mio.\$/year, and deficits descends slowly from then.

## BEV Scenario: Energy price sensitivity

### Energy price: Linear increase to +20% in 2030

#### B: BatCost I & Fuelcost II & Elcost II

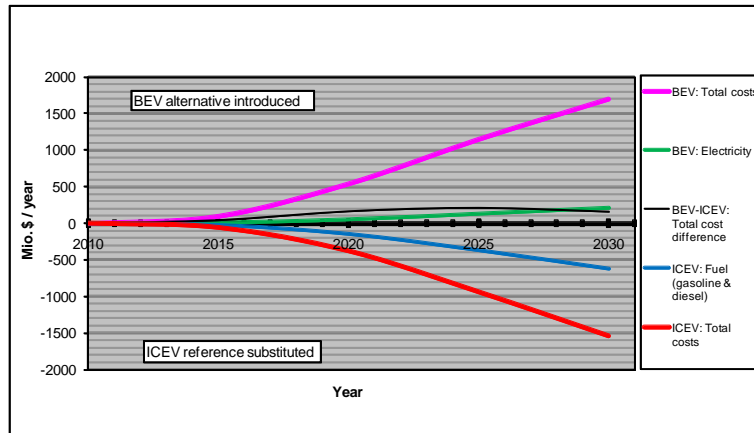

Figure 46 BEV scenario socio-economic costs assuming: BatCost I & Fuelcost I & Elcost I (Linear increase to +20% in 2030) and BatCost I. [Mio.\$/year]

### Energy price: Linear decrease to -20% in 2030

#### C: BatCost I & Fuelcost III & Elcost III

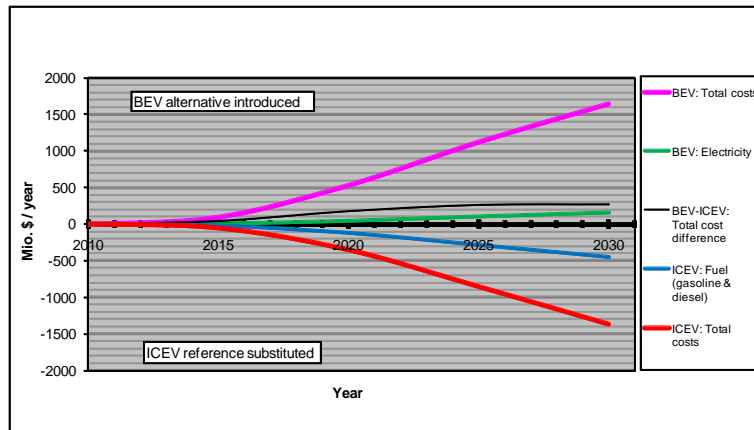

Figure 47 BEV scenario socio-economic costs assuming: BatCost I & Fuelcost III & Elcost III (Linear decrease to -20% in 2030) and BatCost I. [Mio.\$/year]

A general rise of energy prices (both electricity and transport fuels) favours the BEV (and PHEV). This relative advantage is due to their relatively lower operating costs.

The rising energy prices assumed however does not make BEV scenario cost effective during the period. A deficit 2030 of about 150 Mio\$/year still remains in the rising energy cost situation. Lower energy prices favour the reference ICEV and as consequence the relative socio-economic cost disfavors the BEV scenario towards a deficit of about 300 Mio\$/year in 2030.

## BEV Scenario: BatCost II

### Reference energy price assumptions:

#### A: BatCost II & Fuelcost I & Elcost I

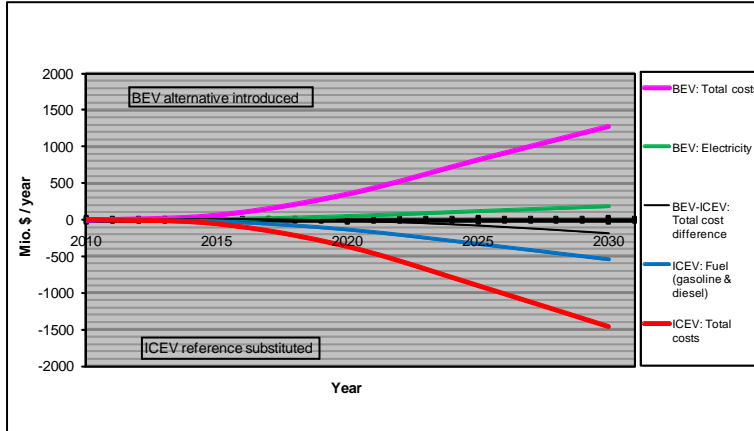

Figure 48 A: BEV scenario socio-economic costs assuming: **BatCost II**, **Fuelcost I** & **Elcost I**. [Mio.\$/year]

Assuming battery costs and lifetime developing according to BatCost II (Ref.: US DOE Recovery Act, 2010) makes the BEV cost competitive to the ICEV before 2020 as seen from Figure 48.

Cheaper batteries and thus cheaper vehicles (BEVs) in this scenario result in an annual socio-economic surplus rising to about 200 Mio\$/year in 2030.

## 4.8 Conclusion on EV scenarios

The following observations and conclusions may be drawn from the marginal PHEV and BEV scenario analyses carried out.

### Energy:

- Electricity substitutes gasoline/diesel via the PHEV and BEV scenarios. Focusing on year 2030:
  - PHEV scenario year 2030:
    - Fuel (net gasoline/diesel) substituted: About 9.0 TWh<sub>fuel</sub>/year.
    - Corresponding PHEV fleet electricity consumption: About 2.5 TWh electricity.
  - BEV scenario year 2030:
    - Fuel (gasoline/diesel) substituted: About 5.4 TWh<sub>fuel</sub>/year.
    - Corresponding BEV fleet electricity consumption: About 1.7 TWh electricity.
- The numbers reflect the relative very high energy efficiency of EV drive trains.
- EVs in the transport sector can diversify its energy resource base and reduce dependency on oil based fuels.

### CO<sub>2</sub> emission and the environment:

- The EV scenario CO<sub>2</sub> emission depends on the power supply system charging the EV fleet.
- According to the Danish ‘reference’ power supply development and assuming *marginal* electricity CO<sub>2</sub> characteristics (CO<sub>2</sub> Case I) for increased supply from this system the PHEVs and BEVs bring only moderate CO<sub>2</sub> reduction (due to coal dominating the *marginal* power production). However, assuming linear descend to zero CO<sub>2</sub> emission in 2050 for the power supply (CO<sub>2</sub> Case III) and assuming *average* electricity CO<sub>2</sub> characteristics substantial CO<sub>2</sub> reduction is achieved in both the PHEV and BEV scenario. (Ultimately in year 2050 the EV transport scenarios have zero CO<sub>2</sub> emission in ‘CO<sub>2</sub> Case III’).
  - PHEV scenario year 2030:
    - CO<sub>2</sub> Case I: About 0.4 million ton CO<sub>2</sub> reduction achieved.
    - CO<sub>2</sub> Case III: About 1.8 million ton CO<sub>2</sub> reduction achieved.
  - BEV scenario year 2030:
    - CO<sub>2</sub> Case I: About 0.2 million ton CO<sub>2</sub> reduction achieved.
    - CO<sub>2</sub> Case III: About 0.9 million ton CO<sub>2</sub> reduction achieved.
- The EV road transport scenarios reduce local pollution and noise.

### Energy system robustness and flexibility: (Observations)

- The road transport system robustness improves due to diversified energy resource basis in the EV scenarios (and security of energy supplies improves).
- Reduced operating costs in EV transport scenarios furthermore increase robustness.
- Oil substitution increases security of energy supplies and contributes to hedging oil price rises.
- EV flexibility as to when to charge may stabilize electricity market prices.
- EV flexibility as to when to charge increases the overall power system flexibility. (Important for integrating fluctuating power production, e.g. wind power.)

### Scenario socio-economy:

- As expected, cost and lifetime of EV batteries much determine the EV economy and the outcome of the PHEV and BEV scenarios.
- Assuming ‘reference’ battery cost development (COWI 2007) the PHEV scenario is close to break-even with reference development. Beyond year 2025 annual socio-economic gains emerge. The BEV scenario, however, show annual deficits throughout the period, though relatively smaller later in the period.
- In an ‘alternative’ battery cost development (US DOE 2010) the PHEV scenario is attractive from year 2015 and throughout the period. This based on a marginal socio-economic analysis and excluding externalities. The BEV scenario becomes cost effective from beyond year 2020.
- CO<sub>2</sub> emission allowance costs are small seen relative to costs of vehicle ownership. Economically this may not change the above conclusions.

### Assumptions made for the socio-economic analyses:

- 1) Monetized issues taken into account:
  - Investment costs
  - Maintenance cost
  - Annual costs of operation (fuel, electricity)
- 2) Issues *not* taken into account:
  - Infrastructure costs
  - Insurance costs
  - Power system flexibility gains (power system regulation capabilities, postpone investments in production/grids etc.)
- 3) Externalities *not* taken into account. E.g. benefit of:
  - Reduced local pollution
  - Opportunities for Danish industry and future employment (‘first mover’ effects)
  - Oil substitution (reduced reliance on oil)
  - EVs effect on hedging for increasing oil prices (and rising transport costs).
  - System robustness and flexibility gains. Security of energy supply (diversified transport energy basis).

As mentioned related to the analysis of individual EVs, most of the externalities *not* taken into account tend to act in favor of the EV scenario alternatives. However, it must be emphasized that infrastructure costs for EV alternatives relative to the ICEV reference cost are not addressed in the present analysis.

## 5 EV and grid interaction

The integration between the electricity grid and the EVs contains a number of challenges with respect to the details of the implementation. In particular when aiming at the V2G functionalities a number of preconditions have to be ensured in order to harvest the full potential benefits.

In this chapter the EV technology will be described (5.1) and how a frame for an infrastructure can be designed for integration of the EV's in the power system. This frame can be seen as a possible realisation on how the reported models can grow up. Some preliminary projects have contributed to the development. First of all availability studies of EV's for charging and/or V2G discharging (5.2) has been discussed - secondly the infrastructure and communication requirements (5.3-4) were investigated. These projects contributed to the establishment of the EDISON project (5.5), which has been running in parallel with this project.

### 5.1 EV technology development

As electrical drive trains for vehicles – when fully developed and mass produced – are expected to become much simpler and cheaper than the present dominating internal combustion engine (ICE) based drive trains, the electrical drives will become the dominating technologies in the future – properly within the next 10 years.

The ICEs have their maximum efficiency, maximum power and maximum torque within limited rotational speed ranges. This implies the need of a complex, expensive and heavy multi stage gearbox and a gear shifting system. The electrical engines can have high efficiency, high power and high torque over a large rotational speed range – high torque even at stand still – eliminating the need for multi stage gearing and clutch. With multi pole electrical engines, designed for relative low rotational speed, the engine can be connected directly to the wheel, eliminating the need for gearing. And ultimately, the electrical engine can be integrated into the wheel, eliminating the need for mechanical driving shaft, which is substituted with flexible electrical wires. The development of suitable electrical engines and the power electronic, controlling the engines, will make the electrical drive train cheaper, lighter and more efficient. Individual controlled engines at each wheel provides in addition true 4-wheel drive options for advanced driving assistance, like curve control and parking assistance.

The transition from the pure ICE-based drive trains to the pure electrical drive trains has turned out to be a step wise development with various complex combinations of ICE and electric engines working in parallel – the various hybrid concepts. The so called series hybrid concepts, with an ICE driving a generator that generates power to the electrical engines, represents in principle a pure electrical drive train, but with a large on-board charger.

The EVs that have been introduced by the car manufactures on the market until now are all rebuilt ICE vehicles, and therefore not optimised. However, the entire vehicle needs to be re-designed. How to best make the vehicle safe? Where to best place the battery modules? How to reduce the energy needed to control the indoor temperature (when cold or hot outside) – e.g. by better thermal insulation? How to design the suspension with the heavy wheel-integrated electrical engines? Can the power converter for the engine (controlling the bi-directional power flow between the battery and the engine while driving) be re-used for the control of the power exchange with the grid (while parked and grid connected) – for V2G, for quick or fast



charging? The Danish ECOMove has an attempt to this – however, not yet introduced on the market.



Figure 49 The ECOMove EV platform and vehicle. (Source: ECOMove, 2011)

There will properly be different versions of the EVs at the future markets – addressing different applications and market segments. The pure battery based electrical vehicles with limited driving range may build up a new market segment where the vehicles are used only for the normal daily commuting, shopping etc. The EVs with an on-board battery charger (a ‘range extender’) may simply substitute most of the present ICE-based vehicles. As the on-board charger must only cover the average power consumption, their power capacities can be limited to 10..20 kW (compared to the typical power capacity of a pure ICE-based engines of 50..100 kW).

The two main types of EVs – the pure battery based EVs and the on-board charger EVs – will have different requirements to charging and will provide different options for power system services. The on-board charger based EVs will have relative small battery capacities (15..25 kWh) and will be less dependent on charging. They will typically charge with relative low power (1..3 kW) at home during night.

The pure battery based EVs will have large battery capacities (25..50 kWh), will require frequent charging (also during the day), will require charging with relative high power (3..5 kW) at home (typically during night), will request fast charging (50..100 kW) (even this option may not be used very often), and may provide extended power system services – e.g. through smart controlled bi-directional power flow – the so called V2G concept.

The pure battery based EVs will have the highest impact on the power system. They will take all the energy needed for driving from the power system (typically 20..40 kWh per EV per day). When returning from their daily duties, they will all be connected at the same time to the outer part of the power distribution system, giving challenges for the power capacity and the voltage stability of the power distribution system. Some EVs will require charging during the day – typically at work (normal charging) and at shopping centres (quick charging, 5..10 kW). And some (properly relative few) will require fast charging – typically along the highways at central fast charging stations, with several charging posts and connected to the power system at medium voltage levels (10..20 kV). In summary: the capacity of the power exchange between the EV and the grid can vary within the relative wide range 1..100 kW.

The impacts of the EVs on the power system are highly dependent on smart control of the EV’s power exchange with the grid – in terms of control of the power level, the flow direction (the V2G concept) and the time of the day. The various impacts can be summarised to:

- Relatively high aggregated charging energy (additional load).

- Relatively high aggregated charging power in the distribution system during night.
- Relatively high aggregated power (properly at medium voltage levels) for central quick charging at shopping centres during the day time.
- Relatively high peak power loads for fast charging at the medium voltage levels.

The aim of the smart control of the EVs is to shift (i.e. postpone) the charging of the individual EVs in time where it is most appropriate for the power system, but at the same time ensuring that the EVs will be charged in due time, as requested by the user. The smart control can be divided into:

- No smart control (the EV will start charging at maximum power when connected to the grid).
- On/off control of the charging.
- Control of the charging power.
- Control of the power exchange between the EV and the grid in both directions (V2G).

The smart charging requires a control signal from the power system to the EV or to the charging post. The intelligence and control can either be centralised or distributed. The centralised intelligence and control requires extensive two-way communication between the central controller (the fleet operator) and the individual vehicles with information of the individual EV's needs and status and with individual power exchange control signals to the EVs. The decentralised intelligence and control requires information to the EVs about the power system needs (for power regulation), incentives for the (owner of) the EVs to react and local intelligences in the EVs to be able to react properly. This can e.g. be obtained through a broadcasted dynamic power price to the EVs (the price that will actually form the basis for the billing account). The dynamic power price concept can be used for all types of smart control, including the V2G.

Depending on the type of power electronic interface between the battery and the grid, the interface unit may provide other power system services on request or automatically based purely on the local conditions (the local voltage or the frequency), like voltage regulation and short circuit power. However, this is not further dealt with in the present study.

On top of this, an appropriate payment scheme between the EV user and the electricity supplier must be implemented.

## **5.2 Availability of EVs in V2G infrastructure**

The future power infrastructure is predicted to contain a much higher percentage of renewable production than today. This will cause several problems to the fluctuating character of renewable sources. Vehicle-to-grid (V2G) is a concept to improve the integration of the electric vehicle and renewable power sources in the future power supply infrastructure. The strain on the infrastructure from unwanted fluctuation in the power production can be relieved by using the unused battery capacity of parked cars as power storage.

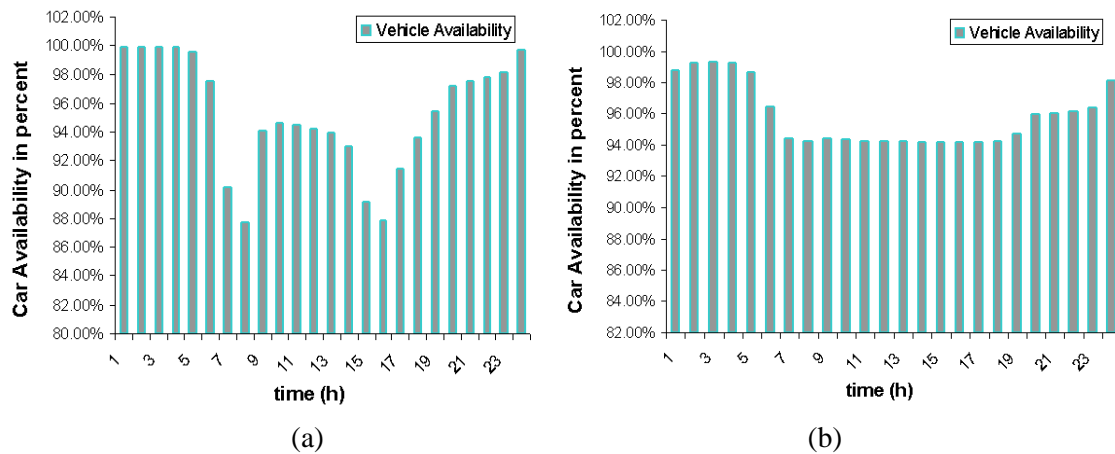

Figure 50 Availability of the Danish personal vehicle fleet. Figure (a) assumes Lyngby's pattern is representative of Denmark. It underestimates the actual minimum availability during regular day. Figure(b) assumes Copenhagen's (Amagerbrogade) pattern is representative of Denmark. It overestimates the actual minimum availability. [5.2]

In [5.1-2] the theoretical infrastructure availability is analyzed for the Danish vehicle fleet. The theoretical infrastructure availability is defined as the amount of cars parked at a given time. Lyngby and Copenhagen are chosen as representative for Denmark. The parking patterns in these two areas are studied in detail and the results is used to estimate the theoretical infrastructure availability hour by hour.

The results show high theoretical infrastructure availability at all times in a normal week. The lowest availability is in the rush hours and the highest is during the night. In the daytime hours the theoretical infrastructure availability is not as high as in the night time but due to commuting traffic it's close to the night time availability.

### 5.3 Intelligent charging and communication/data structures.

The future power infrastructure is predicted to contain a much higher percentage of renewable production than today. This will raise several challenges due to the fluctuating character of renewable power sources.

The electric vehicle and the plug-in hybrid vehicle are predicted to hit the streets in the near future. Vehicle-to grid (V2G) is a concept to improve the integration of the electric vehicle and renewable power sources in the future power supply infrastructure. The strain on the infrastructure from unwanted fluctuations in the power production can be relieved by using the unused battery capacity of parked cars as power storage.

In reference [5.3] the possibilities are analyzed to use the IEC61850 standards to design the data infrastructure in connection to the charging station in a V2G system. The IEC61850 standards are created to describe how to implement distributed energy resources (DER) in the existing power grid. Reference [5.3] focuses on describing an information model for a V2G DER system as shown especially in IEC61850-7-420. The common information model created by TC57 is used to generate an information model for a versatile V2G system.

The results show a perfect match between the demands of a V2G system and the DER systems proposed in the IEC61850 documents. No matter if the V2G system is localized or centralized IEC61850 standards can be applied with great advantage.

Based on the statement above from reference [5.4] it is highly recommended as soon as possible to implement such a communication system for EV's which are connected to the grid. The system infrastructure must be attractive for potential EV- owners in such a way that the infrastructure urge vehicle owners to choose an EV instead of a conventional ICE vehicle.

At an early stage this requires a communication system which must be developed to interface the EV and the power supplier or charging station. The prospected EV's could potentially improve the grid efficiency by levelling loads and thereby decrease the peaks of the electrical consumption curve. Without such communication system, it can be expected that EV's will have the reverse impact, and increase the load peaks in the grid.

To strengthen the interaction between the EV-owner and the power company it is recommended to establish a billing system with some kind of an electricity subscription in combination with other services. An infrastructure with a high penetration of charging stations connected the grid would be ideal. It would be an advantage for the V2G concept if the electricity supplier would install intelligent charging stations at every EV owner's home, were most EVs are parked overnight. By that the EV owner could also benefit of electricity price variations.

It is considered as a great advantage to integrate fast charging stations into the infrastructure. EV's utilizing fast charging will generally not be connected to the grid and may not be able to supply regulating services. Technically battery swapping stations could be a good solution but it is not an optimal solution in respect to the grid. However, the battery swapping station will of course have an energy storage capability which could be integrated into the grid, but that will be in a much smaller scale compared to the battery capacity of the available grid connected EV fleet.

## **5.4 Integration of Wind Power and EV fleet Regulating Power**

In reference [5.5] factors affecting the integration between wind power and electric vehicles are studied – additionally benefits of integrating electric vehicles for the wind energy producers as well as the grid operators in the Danish power system.

The high penetration of wind power has markedly influence on the operation of the power system. The uncertainty of the production quantity increases the request for reserve power capacity while power prices can be from zero up to very high levels depending on wind power production. The last few years' development in battery technology will give a significant opportunity for EVs to play an important role in V2G applications. If EVs will be connected to the grid through nowadays electricity outlets in Danish houses, the distribution grid capacity can limit the power capacity offered by EVs containing big battery packs like Pure EVs and PHEV60s.

There is a real potential for EVs to represent at least 10% of the vehicles fleet in Denmark during the next few years. This increasing number of EVs must coincide with an improvement in the grid infrastructure in order to maximize the benefits of EVs in V2G applications. The daily driving range (about 40 km) for vehicles in Denmark has a limited effect on batteries' stored energy which means that EVs' ability

to provide power for the grid is much higher than EVs ability to consume power from the grid, because the limited need of power for a full recharge of the battery.

With the expected expansion in the number of EVs in Denmark, EVs will not be able to provide all types of ancillary services in both parts of the Danish power system. 155,000 EVs are required to provide all types of reserve energy capacities in Western Denmark. For Eastern Denmark, the number of EVs must be about 200,000. EVs can support wind power production as well as the whole power system by adding load during low consumption periods and returning the energy back to the power system during high consumption periods. Periods with a high surplus of power from the high winds will usually lead to low prices, but utilizing the V2G capability these effects will be perceptible reduced. The charging of 200,000 EVs during low consumption periods will increase the consumption in Western Denmark by about 13%. Furthermore, 2.5% of the total energy consumed in this area can be provided by this number of EVs.

EVs can reduce the mismatch between production and consumption of power caused by wind power forecast errors. For Western Denmark, 120,000 EVs must be available connected to the grid to ensure that. In the case of Horns Rev wind farm, the net output fluctuations as well as the forecast errors can be reduced (almost disappear) by virtually integrating this wind farm with 20,000 EVs. With smoothed production, Horns Rev together with EVs can provide almost all the up and down regulating power purchased by EnergiNet.dk in Western Denmark but that will require an additional 100,000 EVs.

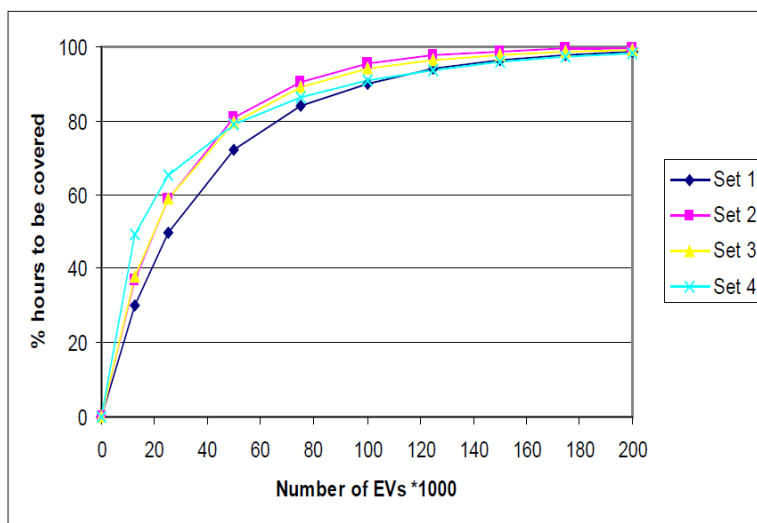

Figure 51 The number of hours (in percent), where EVs are able to cover the deviation between the predicted and the produced power in Western DK. The “Set” relates to the mix of EV’s and PHEV’s. Set 1 is primarily PHEV’s. Set 4 is pure EV’s.

The results presented in the thesis [5.4] indicate that EVs can be the key to ensure a stable and reliable power system in the future, especially if wind power penetration increases to cover 50% of the consumption.

## 5.5 The EDISON project

The feasibility study [5.6] and the works given in summary above were among other sources the back ground for establishing the EDISON project [5.7]. The EDISON project has the overall purpose:

*The purpose of the EDISON consortium is to release the potential for export of Danish technology, system solutions and knowledge by developing and demonstrating an overall economic, reliable and sustainable energy system with large amounts of renewable energy sources (RES) enabled by electrical vehicles (EV).*

*Electric vehicles and plug-in hybrids (PHEV) provide a unique opportunity to reduce the CO<sub>2</sub> emissions from the transport sector. At the same time, EVs have the potential to play a major role in an economic and reliable operation of an electricity system with a high penetration of renewable energy. EV will be a very important balancing measure to enable the Danish government's energy strategy, which implies 50% wind power penetration in the electric power system. An EV will be a storage device for smoothing power fluctuations from renewable resources especially wind power and provide valuable system services for a reliable power system operation. With the proper technology the cars can run on wind power and at the same time enable an increased share of RES in the power system for supply of the conventional electricity demand, and thereby, provide an overall economic, reliable, and sustainable energy system.*

*Denmark does not have a car industry, and the Danish background for development of EVs themselves is limited. On the other hand Danish companies and research institutions have a very strong knowledge and competence regarding design, development, and operation of power systems with high penetration of distributed generation. Furthermore, Danish industry is involved in technologies, which are critical to a widespread use of EVs such as strategy for optimised battery charging/discharging, and power electronics related to battery charging/discharging. This forms an ideal base for development of systems and integration solutions for EVs.*

*The Danish competence can be utilised to develop optimal system solutions for EV system integration, including network issues, market solutions, and optimal interaction between different energy technologies. Furthermore, the Danish electric power system provides an optimal platform for demonstration of the developed solutions, and thereby, provides the commercial basis for Danish technology export. Furthermore, the advantage of being a "first mover" constitutes a business advantage, as well as, a possibility of a strong Danish influence on future standards for system integration of EVs, whereby optimal utilization of the EVs in the power system is obtained.*

*The objective of the consortium project is:*

- *To develop system solutions and technologies for EVs and PHEV which enable a sustainable, economic and reliable energysystem where the properties of EVs are utilised in a power system with substantial fluctuating renewable energy.*
- *To prepare and provide a technical platform for Danish demonstrations of EVs with emphasis on the power system integration aspects.*

- *To develop standard system solutions for EVs, which are applicable globally, by utilising the Danish leading knowledge within distributed energy resources and operation of energy systems with high wind power penetration, and thereby, release the potential for Danish export of technology, system solutions, and knowledge.*

## **5.6 Conclusion**

In this chapter focus has been on availability of EV's for charging and/or V2G decharging and on the infrastructure and communication requirements. It has been demonstrated that there are a number of implementation preconditions and details that are essential for the positive integration of EVs with the electricity grids. Further work is needed in order to find appropriate solutions to the challenges.

The preliminary work from this project has additionally contributed to the establishment of the EDISON project, which is expected to contribute to keep a reliable power system with high penetration of renewables partly by utilizing available EV's as intelligent loads.

## 6 EVs and the Danish Distribution Grid

### 6.1 About the Danish Distribution Grid

The Danish Power System is divided between the western and the eastern part of Denmark. In the western part of Denmark the distribution grid mainly has voltage levels of 60 kV, 20kV, 10 kV and 0.4 kV. In the eastern part the main voltage levels are 50 kV, 30 kV, 10 kV and 0.4 kV.

It is assumed that the most common way to charge EVs will be relatively slow charging during the night. This load would have a point of common coupling (PCC) at the 0,4 kV level. Alternatives to slow charging could be fast charging or battery swapping which most probably would have a PCC at the 10 kV level.

The Figure 52 below shows examples of load patterns for different sectors in the Danish power system. As one can see from the figure, there are big differences between the load patterns of the different sectors / consumer categories.

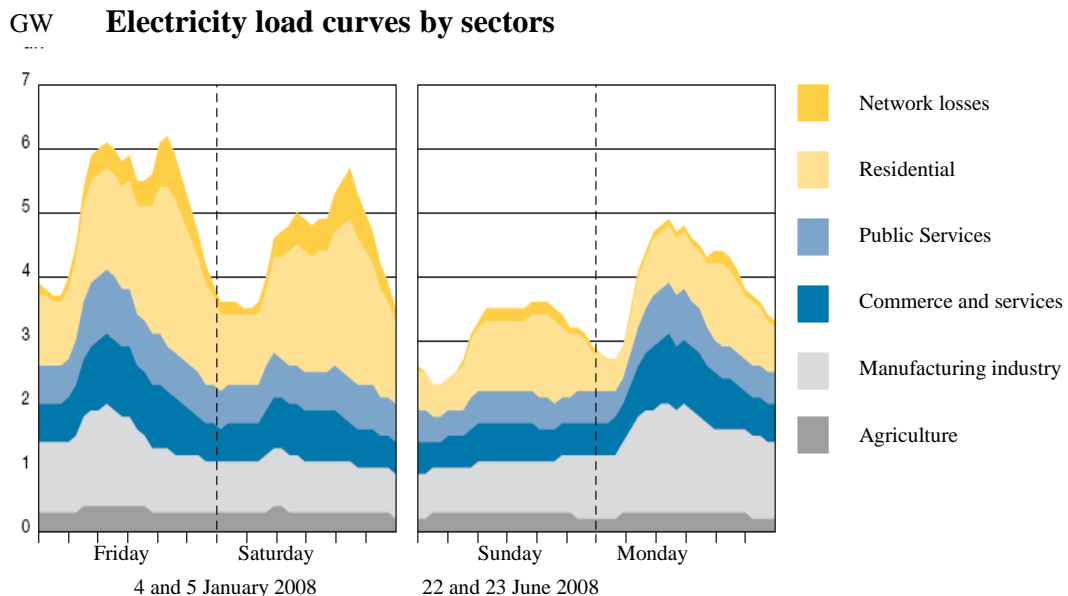

Figure 52 Electricity load curves by sector

Some distribution feeders have mainly consumers of one category while some have a mixture of some or all of the above categories. This is one of the reasons why it is difficult to say something generic about how charging of electrical vehicles will affect loading of distribution grids.

In order to get a good overview it is necessary to do load flow simulations on each type of feeder with expected charging patterns. This is outside the scope of this project, but is a major focus area within the industry and a central topic in other Danish projects. Section 6.2 will show some of the main results from some of these projects.



## 6.2 Results from modelling of EVs impact on distribution grid loading

The home of the EV owner is a location where the EV is likely to be charged very often. Hence the project “Elbiler i lavspændingsnettet” [21] was initiated to analyse the available capacity in 2 different low voltage radials with only residential consumption. Based on the available capacity in the grid, different assumption of charging current and simultaneity of EV charging, the maximum share of houses that could have an EV was calculated:

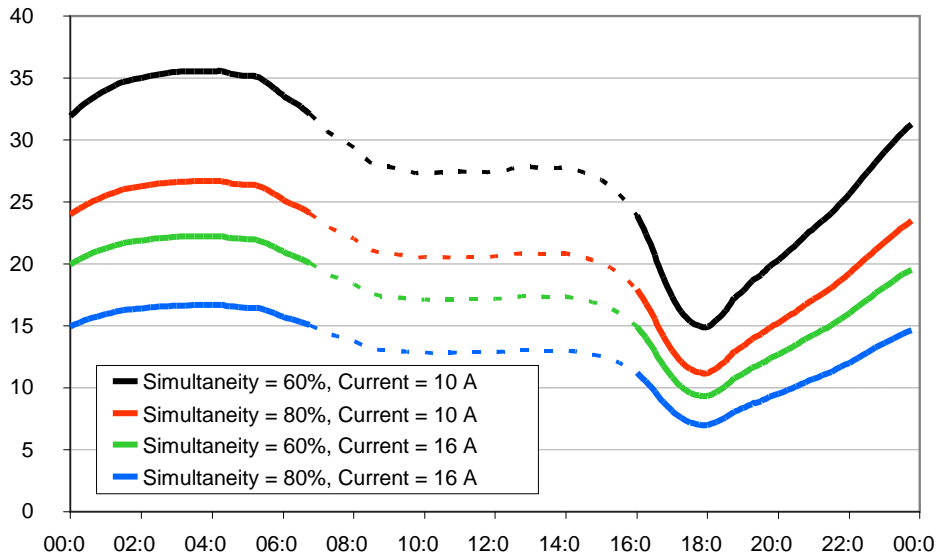

Figure 53. Share of houses that can have an EV as a function of time of charging

In another collaboration between Energinet.dk and Dansk Energi, the Smart Grid project, more extensive analyses was performed on the distribution grid. The low voltage grid of several DSOs (Distribution System Operators) was divided into archetypes according to their properties. The archetypes were subjected to future scenarios with massive deployment of EVs and heat pumps. The figures below show the results of not controlled versus controlled charging of EVs in low voltage grids in areas that is not expected to get heat pumps. It can be seen from the model that controlled charging significantly reduces or delays the need for reinvestments in the grid.

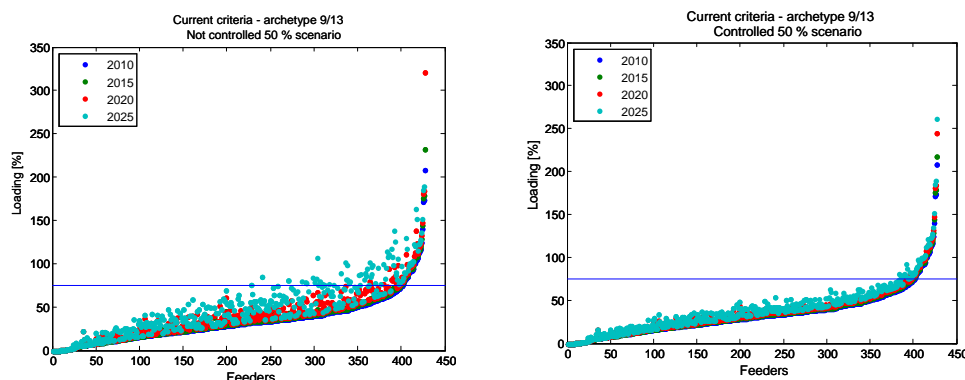

Figure 54 Loading results of not controlled versus controlled charging of EVs in low voltage grids in areas not expected to get heat pumps.

The high level conclusion of the Smart Grid report [22] is that a change to the Smart Grid paradigm will lower the socio economic cost in a future with more fluctuating renewable energy sources and EVs and heat pumps.

In recent years several Danish distribution companies have started to install advanced meter reading systems (AMR). AMR give retailers the possibility to offer contracts to costumers which enables them to be billed according to variable market prices. There are typically not a lot of energy intensive appliances in today's households, which is well suited for price flexible consumption. In the future, however, there could be several potential new appliances that could benefit from price flexible consumption. EVs and heat pumps with heat storage are good candidates among these, since the energy consumption would be a significant part of the total consumption and the consumption can be shifted in time due to the storage feature.

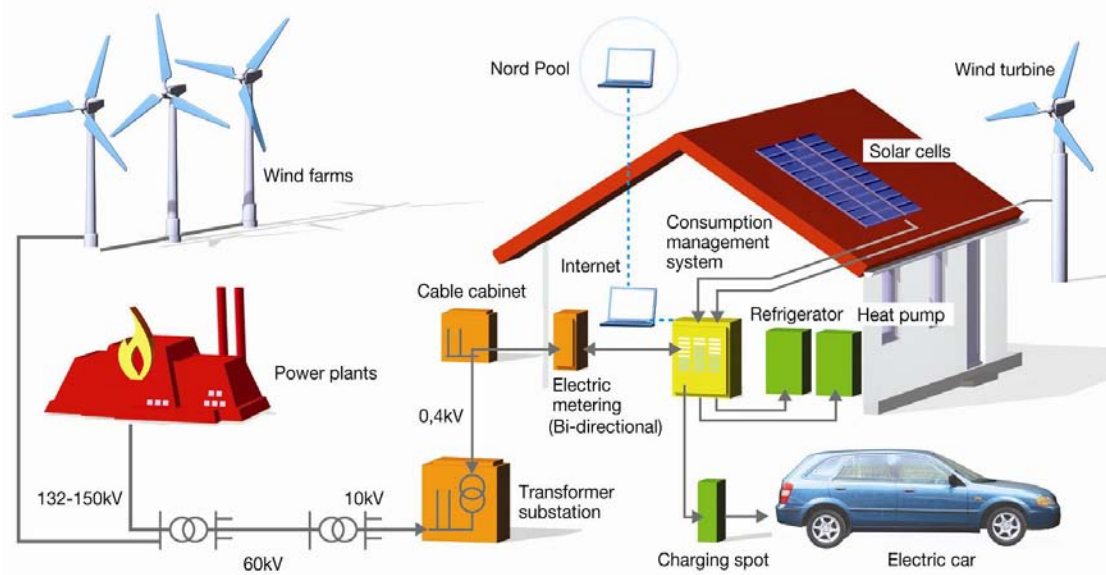

Figure 55 Possible scenario for the future power system

One of the reasons for introducing AMR is to help the power system in implementing more renewable power from sources such as wind, tidal, wave and sun. The common characteristic property of these sources is that they cannot be controlled in the same manner as the conventional power plants – the rated power is less frequently available.

There are two major energy political issues that will shape the future power system in Denmark and Europe. The first and most well known issue is global warming. The second and of less public attention is energy security. This has resulted in the European Union's targets for the year 2020:

- 20 % less CO<sub>2</sub>
- 20 % renewable energy
- 20 % less energy consumption (not binding)

These overall targets have been distributed to the member states, and adjusted according to different preconditions. For Denmark this means that 30 % of all energy consumed in 2020, should come from renewable energy sources. And since the power sector seems to be where

decarbonisation of energy has the lowest cost, Denmark might be looking at a future scenario with 50 % wind power in the power system.

### 6.3 Ancillary power system services' impact on the distribution grid

EVs are seen as a potential supplier of regulating power, since there is a time delay between when the energy is stored in the battery and the real energy consumption (driving). Future EVs are expected to have advanced power electronics that will allow for control of the charging power.

Seen from the DSO side there are two different levels of development when assessing EVs as power system regulation tools:

1. Only start, stop and possibly regulation of charging
2. Discharging of batteries to deliver energy to the grid (also known as vehicle to grid or V2G)

The technical solution for the first part is fairly simple, since it only requires some form of communication between the EV battery charger and the third party which could be the DSO, energy balance responsible, fleet operators / virtual power plant operators or the TSO.

The second part, V2G, may require alternation of protection schemes in some distribution grids. If the amount of energy fed back into the grid will be larger than the consumption in a 0,4 kV feeder line the current will flow the opposite direction of what most distribution grids are designed for. In case of short circuits this might be a problem for the protection system. There will also be a need to make sure that EVs will disconnect in case the mains is lost (avoid unintentional islanding).

Start, stop and regulation of charging and V2G may cause local overloading of distribution grids. The nominal power of the charger and the potential control strategies for charging will determine the total impact the EVs will have on the grid.

### 6.4 Peak load in low voltage grids

The nominal power of fuses and the cross section of cables in the low voltage grid are decided by the expected peak power demand at the location in question. Voltage level, expected growth in power demand and optimal network losses are also parameters that affect the optimal choice of nominal power of these elements.

The dimensioning of Danish distribution grids are based on statistical data for different consumer categories. When a new 0,4 kV radial is to be built the nominal power for the cable is calculated by Velander's function:

$$P_{\max.} = \sum_{i=1}^{i=n} (k_{1,i} * W_i + k_{2,i} * \sqrt{W_i})$$

Where

$P_{\max}$  is the dimensioning power [W] of customer i

$W_i$  is the annual energy consumption [Wh] of customer i

$k_{1,i}$  and  $k_{2,i}$  are Velander coefficients chosen according to the consumer type of customer i.

In Denmark the typical size of a household's main fuse is 25 A. Given an example with 35 households (all having 25 A fuses) on one radial, the size of the fuse in the substation would typically be 250 A. The main purpose of the substation fuse is to protect the cable from short circuit currents. But the fuse must also be large enough so that it does not melt at the time of peak power. Today the different households do not have their peak power demand at the same time, and hence the substation fuse (250 A) can be smaller than the sum of the fuses in the cable cabinets (35\*25 A).

The way that the EV charging will affect the distribution depends on several aspects:

- Power rating of EV chargers
- Consumer driving and charging (and discharging) patterns
- Incentives for smart charging
- Design of power electronics in EVs

## 6.5 Power rating of EV charging

International standards for charging plugs (IEC 62196) for EVs are currently under revision, so it is not possible to know the exact standard for the future vehicles. We do however, know three things today:

1. The EVs on the market today are delivered with chargers with nominal power less than 3.7 kW (230 V, 1-phase, 16 A).
2. A group of large industry players have made a joint effort to create a pre-standard for the plug specifications. The plug in question is rated for 3-phase charging up to 63 A. The plug also has pins for communication.
3. In the future the EV traction inverter may also be used for charging purposes. This means that there will be little additional cost (or negative compared to today's design with 2 inverters) to manufacture an EV that is designed for 43.5 kW AC charging.

If EVs are equipped with chargers that can cope with currents up to 63 A, there will be a need for the car/user to know the maximum power that can be provided by the power outlet in question and a way to adjust the EV charging current.

## 6.6 Voltage flicker

The amount of flicker is a combination of depth/height of dips/spikes and their frequency. Voltage dips and spikes can be seen as flicker in incandescent light bulbs if the frequency of the dips and spikes are in the right range.

Voltage dips and spikes in the low voltage grid are caused by connection and disconnection of large loads. Flicker has been an issue for a long time when connecting electrical motors, which has a large inrush current. This is usually solved by adding soft starters to the motors. The alternative is to reinforce the grid which usually has a higher cost than a soft starter.

EVs would also represent a large load in low voltage grids. Flicker may also here be reduced or eliminated by using soft starting algorithms in charging equipment. Using soft starting of charging may reduce the ability of the EV for delivering fast regulation services. The ramp up for W/s will be longer. It does not disqualify the EVs from delivering fast regulation services; it only means that with soft starters you need more EVs to deliver the same service.

The current recommendations for voltage levels in Denmark are [230\*0,90 V → 230\*1,10 V] measured as average over 10 minutes. This was for many years the dimensioning criteria for several new distribution grids. After the introduction of electrical stoves with ceramic tops several DSOs started to dimension their grids according to flicker limits instead. There are however differences in dimensioning procedures across the industry due to differences in framework conditions and historical reasons.

## 6.7 Asymmetric phase loading

If the EVs that come to the market will be delivered with one phase chargers, they might contribute to more uneven loading of phases. This might accelerate the process of overloading the grid. If EVs will be delivered with 3 phase chargers, the extra load they contribute with will be evenly distributed on the 3 phases. And in the most extreme “intelligent” scenario, they could help compensate for the existing asymmetry in the grid. Uneven loading of phases can cause asymmetric voltages.

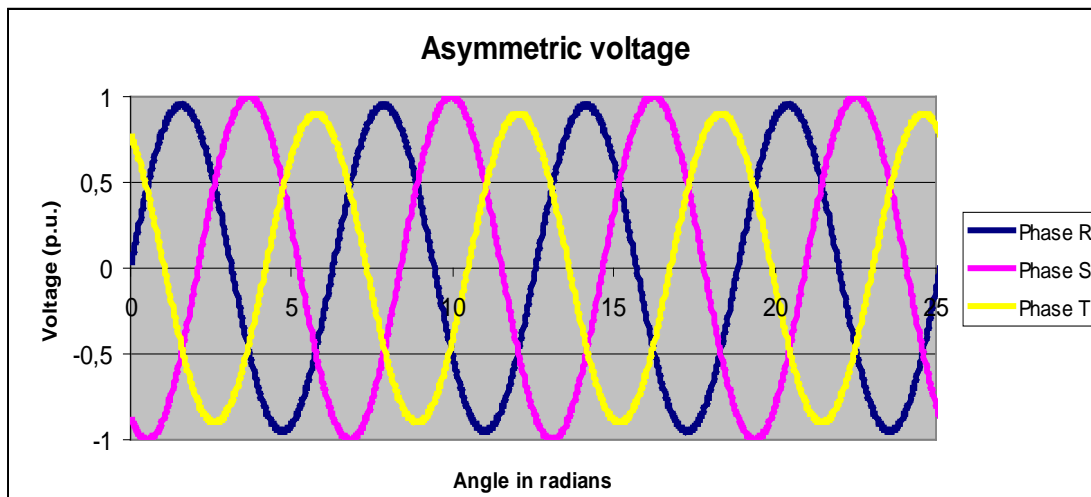

Figure 56 Illustration of asymmetric voltage

Typical problems that can occur, if the voltages in the three phases are asymmetrical, are over heating of motors and disconnection of equipment controlled by frequency transformers and AC/DC converters.

## 6.8 Harmonic distortion

Harmonic distortion is the change in the ideal sinusoidal curve shape of voltage and current in the power system. It is caused by distorting loads interaction with the impedances of the grid. Harmonic distortion may cause heating of induction motors, transformers and capacitors. It may also cause overloading of neutrals.

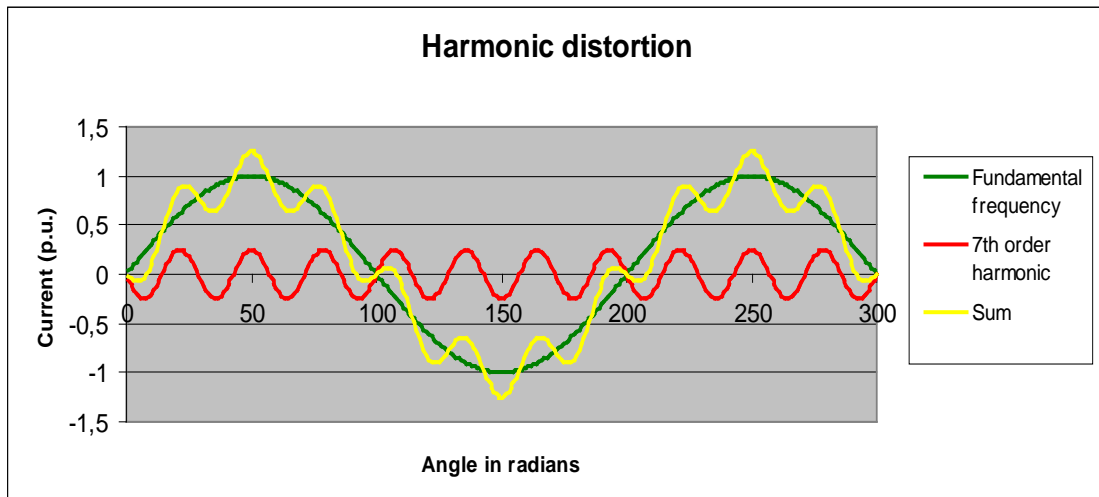

Figure 57. Illustration of harmonic distortion of current

Electric vehicles will be connected to the grid through their chargers. Chargers contain power electronics which by their nature should be considered as voltage distorting elements.

In Denmark, the limits for harmonic distortion in the grid are defined in the DEFU recommendation number 16 and 21.

Loads with a nominal current up to 16 A, which generate harmonics, shall meet the requirements in EN/IEC 61000-3-2 and the DSO cannot add further requirements. Loads with a nominal current between 16 A and 75 A, which generate harmonics, can be connected to the grid if the short circuit level is sufficiently high at the point of common coupling, and the emissions from the apparatus are within the limits of EN/IEC 61000-3-12.

## 6.9 Conclusions

EV and the Danish Distribution Grid:

- The home of the EV owner is where the EV is likely to be charged very often. Home loads would typically have a point of common coupling at the *0.4 kV level in Danish/European distribution grids*.  
Distribution feeders (0.4kV) may serve consumers of much different category in a neighbourhood. Therefore it is difficult to say in general how charging of EVs will affect loading of distribution grids.
- Fast charging or battery swapping charging alternatives would most probably be coupled at the 10 kV level.
- Comparing model results on *distribution grid loading in not controlled versus controlled EV charging* in low voltage grids show that *controlled charging is increasingly important as the EV share rise in feeders*.
- Controlled charging *significantly reduces or delays the need for reinvestments in the grid*.

- *EVs as power system regulation tools* depend on the level of development of the EV-grid interface. For the DSOs (Distribution System Operators) two cases are important. Ability to:
  - Only start, stop and possibly regulation of charging (Fairly simple technical solutions)
  - Discharging of batteries to deliver energy to the grid (also known as vehicle to grid or V2G)
    - V2G may require alternation of protection schemes in some distribution grids.

Start, stop and regulation of charging and V2G *may cause local overloading of distribution grids*. Nominal power of the charger and the potential control strategies for charging will determine the total impact EVs will have on the grid.
- Voltage flicker has been an issue when connecting electrical motors of high load. This is usually solved by adding soft starters to such motors. *EVs may require soft starting algorithms in charging equipment*.  
Using soft starting of charging may reduce the ability of the EV for delivering fast regulation services. *It does not, however, disqualify the EVs from delivering fast regulation services*.
- Furthermore, attention should be paid to potential EV impact on harmonic distortion from chargers. Charging equipment shall meet Danish/EU requirements.

# 7 EVs and their impact on transmission systems

## 7.1 Background

The development of electric vehicles (PHEVs or BEVs) as described in the scenarios outlined in chapters 4.4 and 4.6 has an impact on the power system balance and the transmission system. The impact on the overall power system balance has been analysed. The impact of electric vehicles (EVs) is highly dependent on the charging strategy applied, and therefore various charging modes have been analysed as well.

This chapter elaborates on the impact of EVs and investigates a number of issues:

- Three different charging strategies have been analysed, ie dumb charging, controllable charging and controllable charging with Vehicle-to-Grid (V2G)
- Impact on the demand for additional generation capacity
- Impact of the different charging modes on security of supply
- Supply of ancillary services (technical and operational aspects)
- Impact on transmission line capacity.

The results are based on power system analysis work carried out in the following projects:

- Efficient integration of wind power in Denmark, Energinet.dk, 2009
- Strategy for the investment in 132/150 infrastructure, Energinet.dk, 2009
- Smart Grid in Denmark, Danish Energy Association and Energinet.dk, 2010
- Energy 2050 - development of the energy system, Energinet.dk, 2010.

In general, the analysis was carried out in a power system featuring wind power generation capacity of 6 GW (offshore and onshore), ie a power system where almost 50% of power generation on an annual average is based on wind power.

## 7.2 Different charging strategies

The EV charging strategy applied highly influences the impact on the power system. In the analysis, three different charging strategies have been assessed.

1. Dumb charging:  
The power for the EVs comes primarily from charging performed in the time slot 17:00-21:00.
2. Controlled charging optimised to day-ahead spot market:  
The EVs are charged during the day in the five hours when the electricity day-ahead spot price is lowest. Restrictions on charging fleet availability were included as a constraint.
3. Controlled charging with V2G and Smart Grid functionality:  
Charging is optimised to day-ahead spot market (as mode 2). The EVs supply power to the grid (V2G), and charging is carried out taking account of capacity constraints in the power grid. The max load on the distribution network in the reference situation without EVs is



not exceeded in this controlled charging mode. Restrictions on charging fleet availability were also included as a constraint. During the hours 11.00-15.00, only 50% of the fleet is assumed to be available for charging and during rush hours (from 06.00-10.00 and 15.00-18.00), only 10% of the fleet is assumed to be available for charging.

In this charging mode, EVs are also assumed to be able to provide ancillary services.

### 7.3 Impact on demand for generation capacity

The charging strategy has a significant impact on the requirement for power generation capacity. An analysis of a 2030 scenario featuring a large number of EVs, corresponding to the scenario presented in chapter 4.6, has been carried out. The residual power (given as power demand less wind power generation) is shown for the three charging strategies.

One year has been simulated on an hourly basis, and the hours have been sorted according to the residual power demand (duration curve), as shown below.

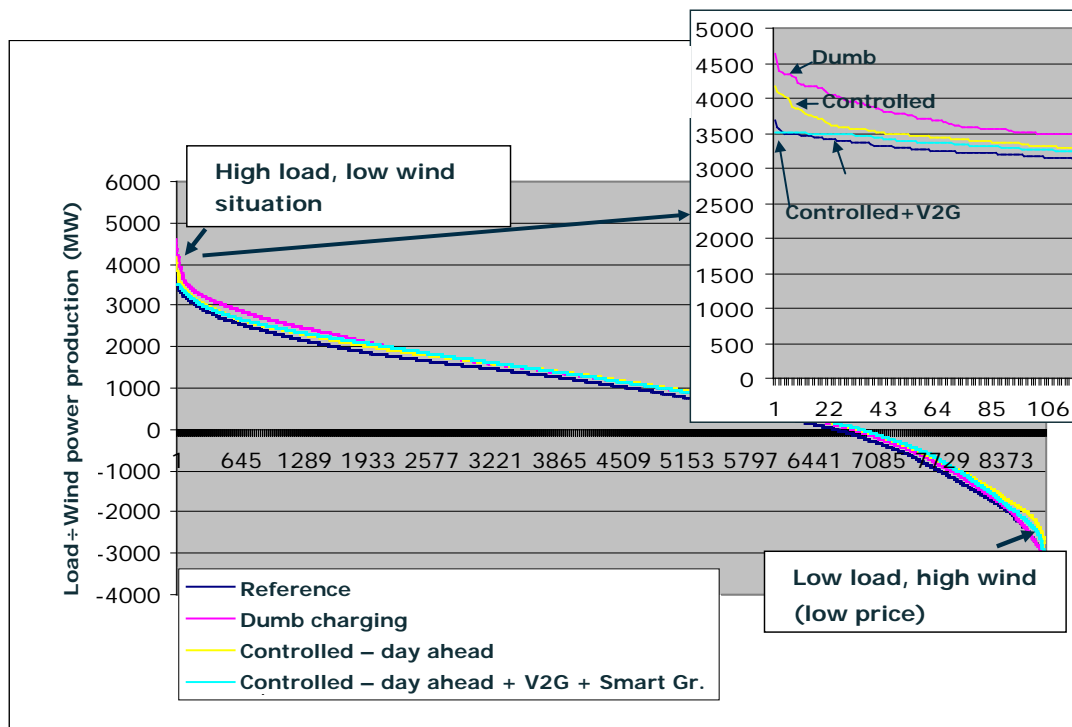

Figure 58 Duration curve, power demand less wind power generation. The three charging strategies are shown.

Hours of low wind power generation and high load are shown (left part of duration curve).

The results show that dumb charging creates a substantially higher demand for additional peak power capacity than the reference situation with no EVs. Controlled charging optimised to day-ahead spot market, as shown in mode 2, reduces the demand for additional capacity but still leads to a significant increase in power demand compared to the reference situation without EVs. Controlled charging with V2G creates a power demand at a level similar to the one in the reference situation without EVs.

## 7.4 Security of supply - power adequacy

The charging strategy applied has a significant impact on power adequacy and the risk of loss of load. A probabilistic analysis using the simulation tool Assess (see appendix) was carried out. The analysis is based on a scenario with a large number of EVs, as given in chapter 4.6. The results are shown in Figure 59 for the three charging strategies and for a reference situation without EVs.

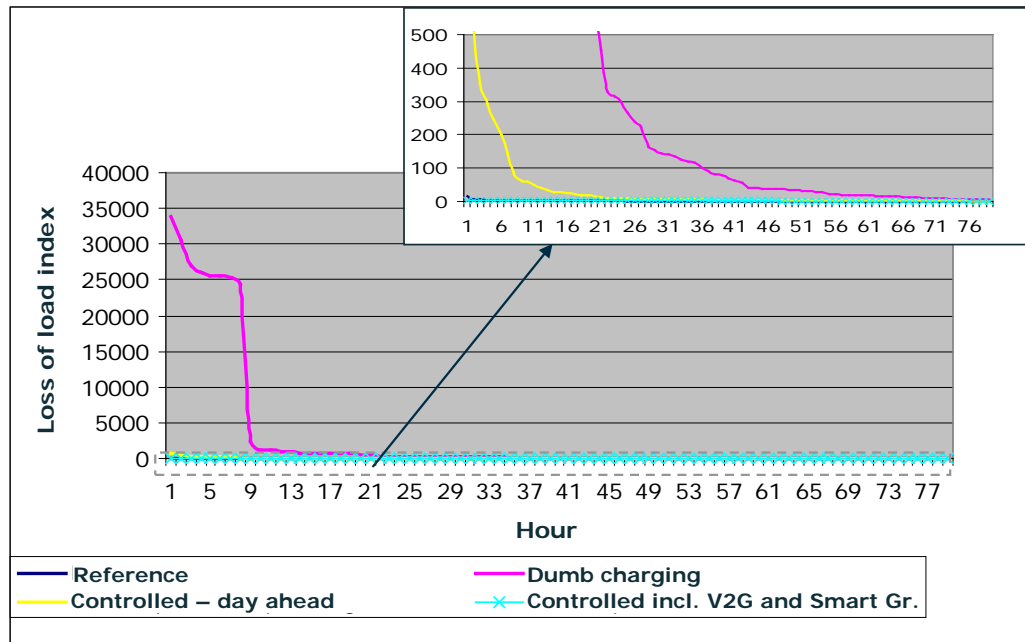

Figure 59 Probabilistic calculation of loss of load for a reference situation without EVs and three different EV charging strategies.

The results in Figure 59 show that the charging strategy has a significant impact on power adequacy, presented as a risk of unserved energy. The analysis is based on a fixed amount of power capacity. The loss of load index is calculated as the statistical risk of unserved energy. The results cover only the analysis of power adequacy at high voltage levels. Dumb charging significantly increases the risk of loss of load, whereas controlled charging with V2G keeps the risk of loss of load at a level similar to the one found in the reference situation without EVs.

## 7.5 Demand for downward regulation of wind power generation

In the power system scenario featuring 6 GW of wind power, downward regulation of wind power generation is required for some hours in order to maintain power system stability. This situation with excess wind power does not result in an unstable power system, and the amount of "lost" generation is rather low. However, the indication is that there are some hours when prices are low or spot prices negative.

The impact of EV charging on excess wind power has been analysed, and the results are shown in Figure 60.

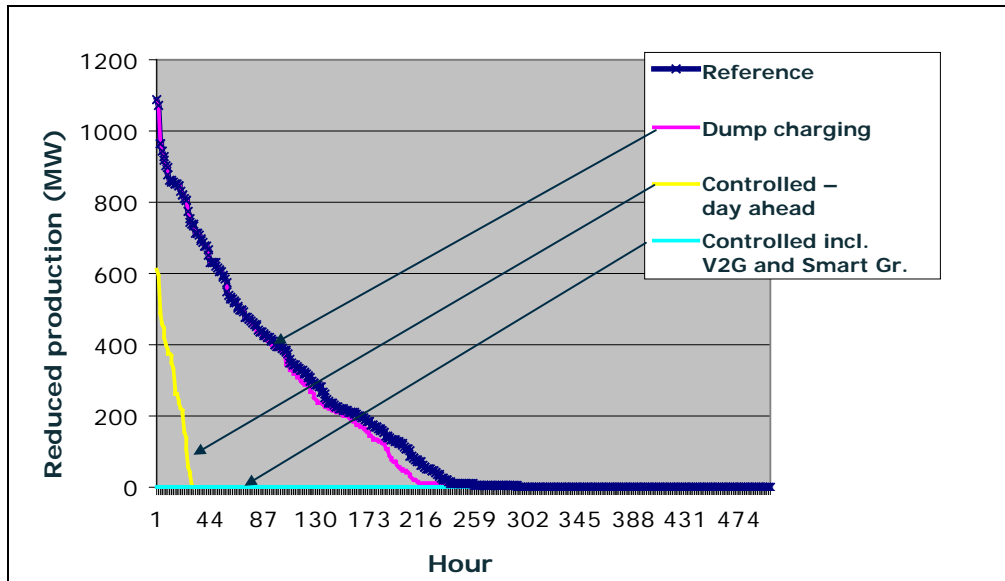

Figure 60 Hours when downward regulation of wind power generation is required, calculated for different EV charging modes and for a reference situation without EVs. The figure shows the number of hours and the corresponding demand for downward regulation of wind power generation.

If EVs are charged in dumb mode (cyan line), the downward-regulated wind power generation is approaching a level similar to the one experienced in the reference situation without EVs (blue line).

Controlled charging without V2G (yellow line) substantially reduces the demand for downward regulation, while controlled charging with V2G almost eliminates all demand for downward regulation of wind power generation.

The analysis shows that having a large number of EVs charged in dumb mode does not significantly impact the amount of wind power which has to be regulated downwards in hours of high generation/low load.

## 7.6 Supply of ancillary services

The hourly balancing of power generation with power consumption is carried out in the hourly spot market (Nordpool day-ahead) and the hourly intraday market (Nordpool Elbas). The transmission system operator (TSO) is responsible for balancing the power system during the hour of operation. This is done by providing and activating the amount of ancillary services required during the hour of operation.

The ancillary services can roughly be divided into the following categories:

1. Primary reserves (frequency response, seconds)
2. Secondary reserves (minutes)
3. Tertiary reserves (within 15 minutes).

Furthermore, system services involving the supply of:

4. Voltage control and reactive power control
5. Inertia
6. Short-circuit power

are required to obtain power system stability together with an acceptable frequency and voltage quality.

BEVs and HPEVs could potentially provide ancillary services, and depending on the type of ancillary service there is a need for:

- A controllable converter to be used for charging. This could either be a controllable rectifier (uni-directional power flow) or a 4-quadrant converter (bi-directional power flow with controllable active and reactive power flow)
- A power system which communicates the demand for ancillary services to the EV operators, eg Smart Grid
- A market solution (real-time market, virtual power plant, etc.) for activating "small-scale" ancillary services.

### Primary reserves

The primary ancillary services are based on frequency response load characteristics. In Denmark, approximately 50 MW of primary reserves is required.

Frequency detection can be carried out locally by the electrical vehicle to provide the fast frequency response.

If a capacity of 1 kW is left on each EV for the supply of ancillary services, approximately 50,000 connected EVs (without V2G) will be required to supply the capacity needed.

### Secondary and tertiary reserves

The demand for secondary and tertiary reserves is approximately 100 MW and 500-700 MW, respectively.

Estimates indicate that with V2G a fleet of 200,000 EVs connected to the power system could supply the amount of tertiary services required most of the time.

### Voltage control and reactive power control

The EV converter can (technically) regulate the amount of reactive power it consumes/produces and provide voltage control in the grid. The purpose of this is to reduce undesirable amounts of reactive power in the distribution system and to provide voltage control.

A state-of-the-art Smart Grid system and power converter are required to obtain the information needed for appropriately controlling the reactive power consumption of EVs.

### Inertia and short-circuit power

In the main power system, "inertia" is required to stabilise the system.

Today, this inertia is primarily supplied by large power stations. Units equipped with power converter systems can to a certain extent be controlled to emulate inertia (virtual inertia).

This requires a fast regulation system, and the experiences gained and perspectives must be investigated further.

Short-circuit power is required in the system, primarily for HVDC thyristor commutation and relay protection systems. Because of power electronics, converters are unable to supply a high short-circuit current, and with the current technology they are considered incapable of providing this system service.

## **7.7 Transmission line capacity (>100 kV)**

EV charging poses a challenge to the power system at low voltage levels. In transmission lines with a voltage level higher than 100 kV the power flow is - due to power transit and wind power generation - more challenging than the potential, increased power flow resulting from EV charging.

A long-term power transmission strategy (> 100 kV) has been adopted /Strategy for investment in 132-150 kV infrastructure, Energinet.dk, 2009/

In power infrastructure design, account has been taken of the demand for EVs. A design analysis of the main power infrastructure (>100 kV) shows that if the power consumption of EVs is stochastic, then the infrastructure is stable. However, "timer-controlled" charging without a Smart Grid strategy, which may result in the majority of the EVs being charged at the same time due to low power prices, could sharply increase power demand. This could pose a challenge to the power system and system stability.

## **7.8 Conclusion**

A scenario with a large number of EVs (BEVs and PHEVs) has an impact on the power system. This impact has been analysed, and the results show that the impact is highly dependent on the charging strategy applied.

If EVs are charged in "dumb" mode, there will be a considerable demand for additional generation capacity to maintain power adequacy and security of supply. Controlled charging focusing on day-ahead spot prices could significantly improve the efficient use of wind power and the existing controllable generation capacity.

The V2G functionality could further reduce the demand for additional power capacity.

EVs can supply ancillary services, the value of which is further investigated in Chapter 10. With or without V2G, EVs can technically deliver primary, secondary and tertiary reserves. As the electrical vehicle is a relatively small resource (compared to power stations), the

development of strategies and market solutions to take advantage of this source of ancillary services poses a challenge.

Whereas the impact of EVs on grid capacity requirements at the low voltage levels is an issue, the impact on the demand for increased grid capacity at transmission levels ( $> 100$  kV) is relatively small. Moreover, at transmission level, the impact on the demand for generation capacity and the potential impact on frequency stabilisation are specific focus areas.

## 8 EV modelling in Balmorel and Wilmar

A number of analyses of EVs as part of the power system have been developed using Balmorel and Wilmar. The analyses are described in the following two chapters, while here the modeling of EVs as part of those two models is dealt with.

Both of the models are versatile in their description of the power system, including the CHP plants connected to the power network, and embedding the model in an international context. However, the analyses of EVs as part of the power and CHP system have necessitated development of additional facilities within the models. The facilities aim at representing EVs at a level of detail and with types of functionalities that are comparable with the overall characteristics of the models.

### 8.1 Modelling electric vehicles in Balmorel

A transport add-on has been developed for the Balmorel model, enabling analyses of EVs. The model has been developed by Nina Juul and Peter Meibom as documented in [85]. A summary of the EV implementation in Balmorel is provided in this section.

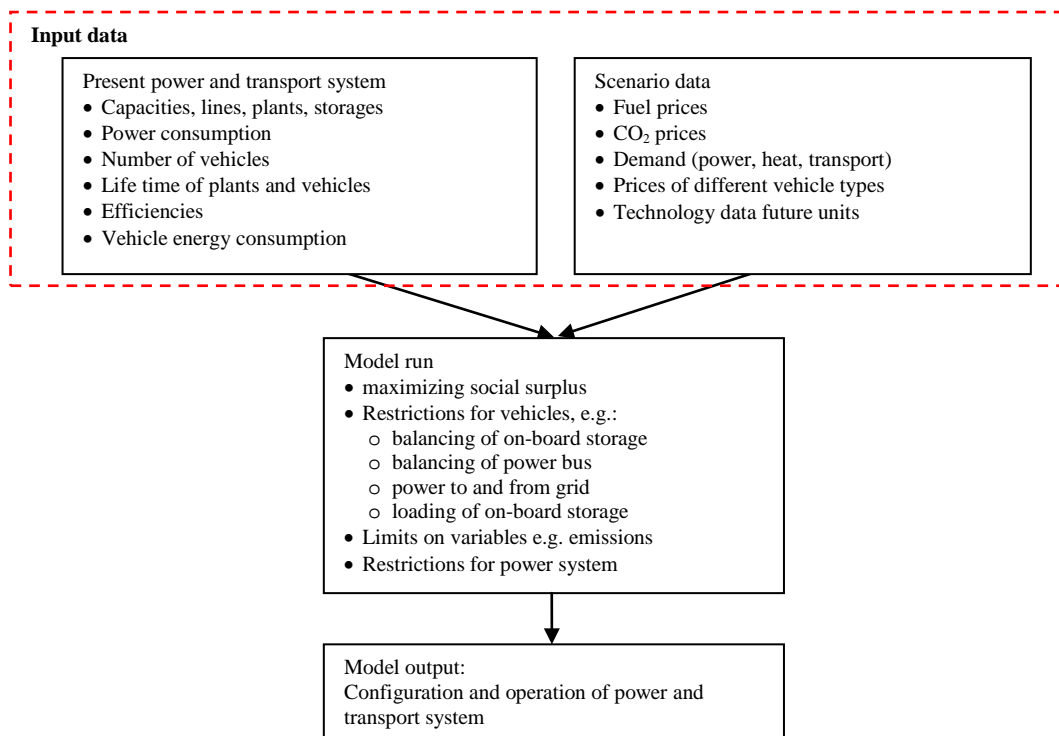
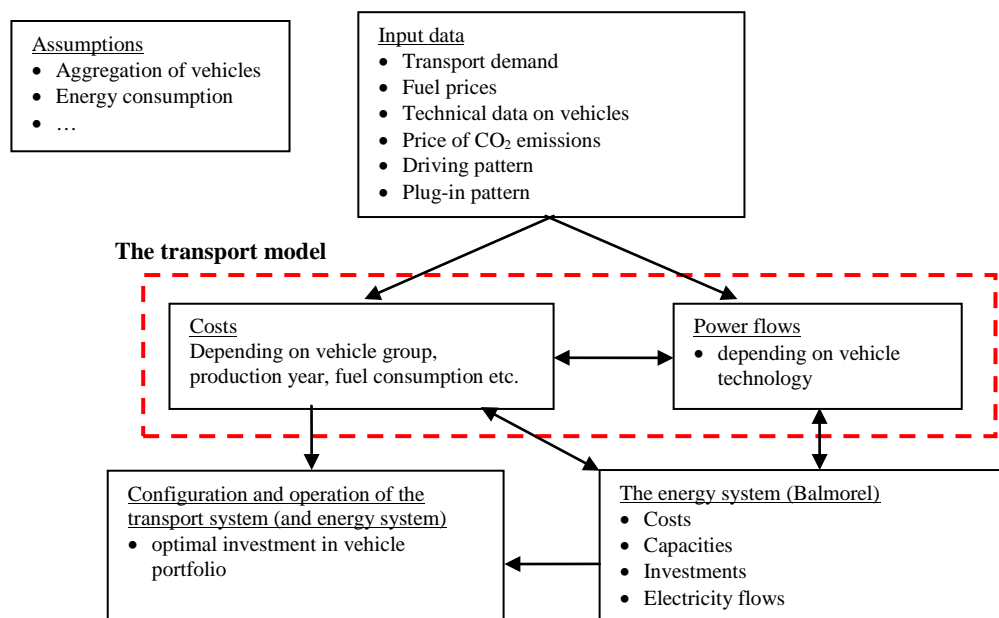

Figure 61 Sketch of the Balmorel model including transport

The integrated power and transport system model is a partial equilibrium model [84, 86] assuming perfect competition. The model (*Figure 61*) minimises operational costs subject to constraints, including renewable energy potentials, technical restrictions, and balancing of electricity and heat production. Investments are generated in order to optimise the operation and configuration of the power system and electricity prices are derived from marginal system operation costs.

In Balmorel the geographical entities are, countries, regions, and areas. Countries are divided into regions which are then subdivided into areas. Electricity and transport supply and demand is balanced on a regional level, whereas district heating supply and demand is balanced on an area level. Balmorel works with a yearly optimization horizon and an hourly time resolution that can be aggregated into fewer time steps. Time aggregation is typically used when computation time is important.



*Figure 62 The transport add-on in Balmorel*

The transport add-on in Balmorel (*Figure 62*) includes electricity balancing in the transport system as well as in the integrated transport and power system. Only road transport in passenger vehicles has been included so far. Inclusion of the remaining road transport is a question of data availability. The following vehicle technologies have been included: internal combustion engine vehicles and EVs, where EVs cover BEVs, PHEVs, and FCEVs (Battery Electric Vehicles, Plug-in Hybrid Electric Vehicles and Fuel Cell Electric Vehicles, respectively). Vehicles that are not pluggable do not provide flexibility to the power system and are treated in a simplified way by the power system. Reasons for enhancing Balmorel to include EVs are that it enables analysis of [85]:

- Economic and technical consequences for the power system of introducing the possibility of using electrical power in the transport sector, either directly in electric drive vehicles (EVs) or indirectly by production of hydrogen or other transport fuels.



- Economic and technical consequences of introducing V2G technologies in the power system, i.e., battery electric vehicles (BEVs) and plug-in series hybrid electric vehicles (PHEVs) being able to feed power back into the grid.
- Competition between different vehicle technologies when both investment and fuel costs of the vehicles and the benefits for the power system are taken into account.

Three different propulsion systems are defined in the transport add-on:

1. Non-plug-ins
2. BEVs
3. Plug-in series: including both PHEVs and FCEVs

The power flow in the vehicle is modelled for each propulsion system except for non-plug-ins where only annual driving and fuel consumption are taken into account. Configurations of the propulsion systems are similar. The interactions between the different entities in the EVs are shown in Figure 63. Power can go both ways from storage to power grid (V2G and G2V) and from storage to driving wheels.

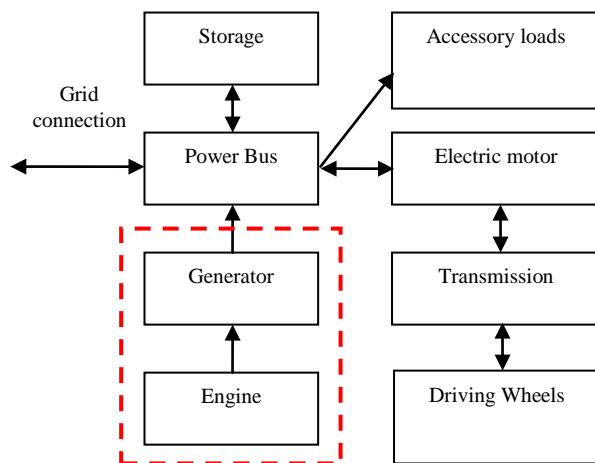

- - - - - Applicable for PHEVs propulsion systems

Figure 63 Propulsion system configuration of (series) electric drive vehicles

It is important for the integrated power and transport system model to keep track of the available power in each time period. The available power stored in the EVs is dependent on, e.g. storage leaving and arriving with the EVs, as well as storage loaded or unloaded from the grid. For the PHEVs and FCEVs it is assumed that storage is depleted before using the engine, due to simplicity and the fact that electricity is a cheaper propellant than both diesel and hydrogen. Also, the batteries are assumed to have no loss of power before almost depleted. Thus, the motor is able to perform as demanded down to the minimum state of charge.

Furthermore, all EVs vehicles are assumed to leave the grid with a fixed load factor (thus, level of storage), restricting the loading and unloading to meet this load factor.

## 8.2 Modelling electric vehicles in Wilmar

The Wilmar model has been enhanced with an EV model. The work has been carried out by Juha Kiviluoma and Peter Meibom and is documented in [81]. This section contains a short introduction to the Wilmar model and a presentation of the EV implementation.

The main functionality of the Wilmar model is embedded in the Scenario Tree Tool (STT) and the Scheduling model (SM).

The Scenario Tree Tool generates stochastic scenario trees containing three input parameters to the Scheduling Model: the demand for positive reserves with activation times longer than 5 minutes and for forecast horizons from 5 minutes to 36 hours ahead (in the following named replacement reserve), wind power production forecasts and load forecasts. The main input data for the Scenario Tree Tool is wind speed and/or wind power production data, historical electricity demand data, assumptions about wind production forecast accuracies and load forecast accuracies for different forecast horizons, and data of outages and the mean time to repair of power plants. The demand for replacement reserves corresponds to the total forecast error of the power system considered which is defined according to the hourly distribution of wind power and load forecast errors and according to forced outages of conventional power plants.

The Scheduling model is a mixed integer, stochastic, optimisation model with the demand for replacement reserves, wind power production forecasts and load forecasts as the stochastic input parameters, and hourly time-resolution. The model minimises the expected value of the system operation costs consisting of fuel costs, start-up costs, costs of consuming CO<sub>2</sub> emission permits and variable operation and maintenance costs. The expectation of the system operation costs is taken over all given scenarios of the stochastic input parameters. Thereby it has to optimise the operation of the whole power system without the knowledge which one of the scenarios will be closest to the realisation of the stochastic input parameter, for example the actual wind power generation. Hence, some of the decisions, notably start-ups of power plants, have to be made before the wind power production and load (and the associated demand for replacement reserve) is known with certainty. The methodology ensures that these unit commitment and dispatch decisions are robust towards different wind power prediction errors and load prediction errors as represented by the scenario tree for wind power production and load forecasts.

Technical restrictions of power plants included in the model are minimum and maximum stable generation level, minimum number of operation hours and shut-down hours, start-up times, piece-wise linear fuel consumption curves and ramp rates. Further restrictions apply for combined heat and power plants and for electricity and heat storages.

Hydropower with reservoir in principle requires a planning horizon of a year or more in order to distribute the hydro inflow optimally across the year. The model simplifies this decision problem using a historical time series for the optimal hydro reservoir level in each region during the year. The model reduces the production costs of hydro power when the reservoir level in the model becomes higher than the historical optimal level and the opposite when the

reservoir level becomes lower than the historical level. This ensures that the historical optimal reservoir level during the year is followed closely in the model.

System reserves are treated endogenously within the Scheduling model. Hence, the allocation of individual types of reserves over different power plants represents one of the optimization results. The main division between categories of positive reserves is between spinning reserves that can only be provided by synchronised units due to the short activation times of these reserves, and reserves which can be provided by both synchronised and desynchronised units with short start-up times, in particular tertiary reserves.

The transmission network is represented by splitting the geographical area modelled into a number of model regions, with each model region containing a number of production and storage units and having scenario trees of load forecasts, wind power production forecasts and demand for replacement reserves. The model regions are connected by transmission lines described by a transmission capacity and an average loss.

As it is not possible to cover the whole simulated time period with only one single scenario tree, the model is formulated by introducing a multi-stage recursion using rolling planning. Therewith, the unit commitment and dispatch decisions and the planned power exchanges are reoptimised taking into account that more precise wind power production and load forecasts become available as the actual operation hour gets closer in time, and taking into account the technical restrictions (e.g. start-up times, minimum up and down times) of different types of power plants. The resulting production of each power plant and the changes in the production and power exchange (up and down regulation) relative to the day-ahead production and power exchange plan are calculated for each hour.

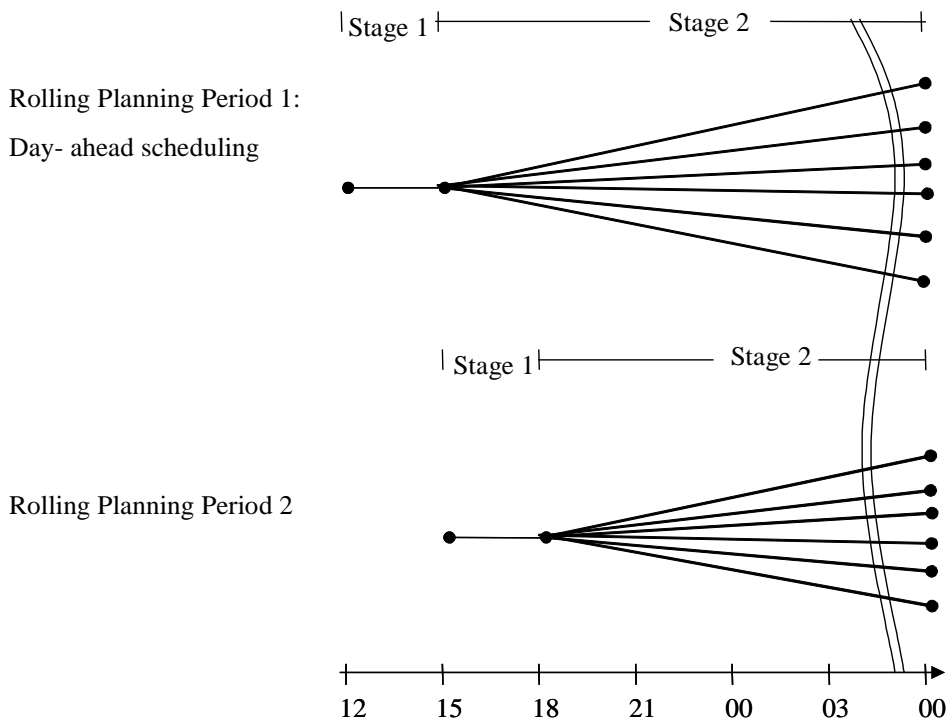

Figure 64 Illustration of the rolling planning and the decision structure in each planning period.

The model steps forward in time using rolling planning with a three hour step, so a one-day cycle consists of eight planning loops. For each time step new forecasts (i.e. a new scenario tree) that consider the change in forecast horizons are applied. This decision structure is illustrated in Figure 64 showing the scenario tree for two planning periods.

Further and more detailed information about the Wilmar Planning Tool can be found in [81, 83]

### The EV model

The model for EVs treats the vehicles as electricity storages which are not always connected to the power grid and, while gone, spend some of their stored electricity. Each vehicle type has its own general electricity storage pool in each model region. It would naturally be more correct to have separate storage for each vehicle, but the problem would not be possible to solve with thousands of vehicles, and therefore simplifications were made. When a vehicle leaves the network, it takes the required amount of electricity from the storage pool and when it arrives in the network, it releases what's left to the pool. It also takes away the amount of storage capacity its battery has and gives it back upon arrival.

Day-ahead plans for charging and discharging are determined during the clearing of the day ahead spot market. The charging and discharging plans can be modified by up or down regulation during the intraday solves, taking updated wind power production and demand forecasts into account.

The model has to take into account the size of the vehicle group which arrives to the grid at a certain time in relation to the departure time of that group. Figure 65 shows an example pattern of EVs that arrive at 7 pm in the network. Some of them had left in the morning and some of them during the afternoon. This influences the calculated consumption of electricity during the trip, since the distribution of trip lengths varies throughout the day.

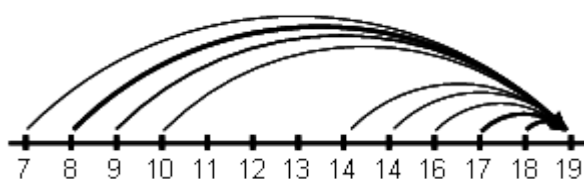

*Figure 65 Simplified example pattern of electric vehicles arriving at the power grid at 19.00h. The thicker the line, the greater the share of vehicles which return to the network at that time.*

Furthermore, there can be system benefits if the batteries do not need to be completely full upon departure. Partially full departing batteries can provide additional flexibility for the power system and be economic in situations where electricity prices have been exceptionally high during the previous charge opportunity. Partially full departing batteries can be realistic in situations where a person either owns a PHEV or normally drives short daily distances by means of an electric vehicle that has a long range.

The use of batteries for reserves is restricted by the amount of stored electricity. There has to be enough electricity in the batteries to be able to produce for a while, if there is a need to use the committed reserves. Reserves can be provided by reserving increased/decreased charging/discharging capacities for this purpose.

The model can handle both full electric vehicles (BEVs) and PHEVs. In the data set, PHEVs have lower average consumption of electricity during road trips, since it is assumed that some part of the total mileage is done with the energy from the engine. This was calculated from the trip lengths in the vehicle travel data. A small share of PHEVs can also run their engine to produce power or ancillary services for the grid while being plugged in.

In addition to the specific restrictions on charging/discharging and provision of reserves, the charging and discharging of EVs determined a day ahead are included in the day-ahead electricity balance equation and likewise with the up or down regulation of charging or discharging being included in the intra-day electricity balance equations.

A detailed presentation of the EV model in Wilmar can be found in [81]

### **8.3 Conclusions**

Electric vehicle models has been developed and implemented in the Balmorel and Wilmar models.

In the Balmorel model the EV sub-model permits analyses of simultaneous operation and investments. Thus, it is possible to take fixed assumptions for the introduction of EVs and then analyze the development of investments in the power system; this functionality was applied for developing the scenarios applied in Chapter 9. It is also possible to take fixed assumptions for power system development and analyze EV investments in this context; this functionality was applied for developing the scenarios applied in Chapter 10. It is also possible to combine the two approaches.

For the Wilmar model the sub-model enables day-ahead scheduling of the charging and discharging of EVs followed by rescheduling of the day-ahead charging/discharging in order to handle wind power and load forecast errors. EVs are capable of delivering both minute reserves and fast automatic reserves (primary and secondary reserves in the terminology of the UCTE grid code). The influence of driving patterns and the restrictions caused by the sizes of the vehicle batteries and the grid connections of the vehicles is included in the model.

With these parts included, the models represent EVs at a level of detail and with functionalities that are comparable with the overall characteristics of each of the models.

## 9 Balmorel model results – EVs and power system investments

The overall goal of this analysis is to investigate how a gradual large-scale implementation of plug-in hybrid electric vehicles (PHEVs) and battery electric vehicles (BEVs) in the private passenger vehicle fleet will influence power system investments and operation in the years towards 2030. The analysis covers not only the Danish power system but also the power systems of Germany, Norway, Sweden and Finland. This is due to the importance of electrical interconnections and in order to reveal possible differences in the effects of EVs on different power systems. However, main focus is put on the effects on the Danish energy system.

The idea of the analysis is to investigate how the power system will be affected by the increase in electricity demand due to introduction of EVs and by the flexibility of this demand when assuming intelligent charging of the vehicles. Moreover, the effect of activating vehicle-to-grid capabilities is investigated by assuming that EVs can deliver power back to the system when needed.

In the following, the scope, preconditions and results of the analysis are presented. Input data and further modelling preconditions for the analysis are given in Appendix 12.3.

### 9.1 Scope and preconditions

The assumed implementation of private passenger electric vehicles (EVs) is based on scenarios set up by the Electric Power Research Institute (EPRI) [91] and IEA [92]. In the Medium scenario, EPRI assumes a development in PHEVs new vehicle shares as outlined in Figure 66a. Based on the relative development in sales of PHEVs and BEVs towards 2030 presented by IEA in the Blue Map scenario, we assume additional BEV market shares corresponding to half of the PHEV new vehicle shares. As a result, we consider a development in the vehicle fleet shares towards 2030 as illustrated in Figure 66b. Consequently, EVs are assumed to comprise around 2.5 %, 15 %, 34 % and 53 % of the private passenger vehicle fleet in 2015, 2020, 2025 and 2030, respectively. This development in the vehicle fleet shares is assumed for all the Northern European countries.

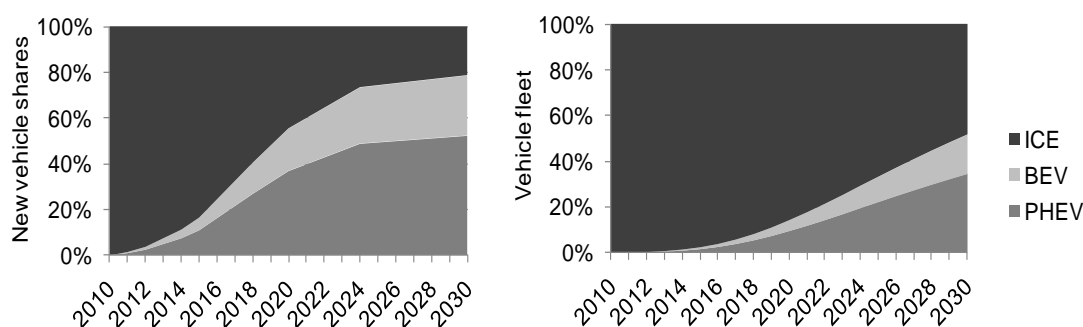

Figure 66 a) Development in plug-in hybrid electric vehicles (PHEV) new vehicle shares in the Medium scenario in [91] and illustration of the assumed relation between battery electric vehicle (BEV) and PHEV new vehicle shares based on the Blue Map Scenario in [92]. b) Assumed gradual penetration of PHEVs and BEVs in the vehicle fleet (ICE: Internal Combustion Engine vehicles).

To analyse the impacts of EVs over the period, two scenarios are set up:

- **Base:** Only internal combustion engine (ICE) private passenger vehicles towards 2030
- **EV:** Gradual implementation of PHEVs and BEVs as private passenger vehicles towards 2030 (as outlined in Figure 66b)

The power, district heat and transport system is modelled in integration using the model Balmorel including the transport-addon developed by Juul and Meibom in [93]. Model development has been made in order to handle the gradual implementation of different vehicle vintages towards 2030. Balmorel is a deterministic partial equilibrium model assuming perfect competition optimising investments in power/heat production, storage and transmission capacities and minimises total costs in the energy system - covering annualised investment costs, operation and maintenance costs of existing and new units, as well as fuel and CO<sub>2</sub> quota costs (the model is further described in the Chapter 12.2). The transport-addon includes demand for transport services, vehicle investment and operation costs and electricity balancing in the integrated road transport and power system. As the gradual implementation of PHEVs and BEVs is fixed, investments in vehicles are in this study not performed as part of the optimisation.

Simulations are made with five year intervals, for 2015, 2020, 2025 and 2030, where optimal investments identified in previous years are included in the optimisations of subsequent years. Plug-in patterns for BEVs and PHEVs have as in [93] been derived from driving patterns obtained from the investigation of transport habits in Denmark [94]. It has been assumed that the EVs are plugged-in at all times when parked and that driving habits are the same for all the countries in the simulation. Optimal vehicle-to-grid and grid-to-vehicle power flows are identified as part of the optimisation.

All EVs are assumed to leave the grid with a fully charged battery, restricting the loading to meet this load factor. The PHEVs are assumed to use the electric storage (the usable part of the battery) until depletion before using the engine. This is considered a reasonable assumption due to the high efficiency of the electric motor compared to that of the combustion engine as well as the low price of electricity (average prices in the neighbourhood of €50/MWh in the simulations) compared to the price of diesel (64-80 €/MWh in 2015-2030 [95]). The model works with a capacity credit restriction ensuring enough production capacity to meet peak power demand as presented in [96]. BEVs and PHEVs are due to V2G capability able to contribute in meeting peak power demand. Modelling of this contribution is taken from the PhD thesis by Nina Juul [97].

Integrating the power and transport systems and introducing intelligent charging/discharging requires a number of additions to the existing system, e.g. communication between vehicles and the power system, vehicle aggregators communicating with power markets, and agreement upon connection standards. All such changes are in the model assumed to be in place and infrastructure costs, e.g. charging stations and hardware, are not included.

In the analysis, investment in the following unit types is allowed:

- Wind turbines (onshore, offshore)
- Coal CHP, steam turbine, extraction
- Natural gas CHP, combined cycle gas turbine, extraction
- Natural gas open cycle gas turbine, condensing
- Nuclear power, condensing (in Finland and Sweden only)
- Biomass CHP, medium, extraction (wood chips), Biomass CHP, small, backpressure (wood chips), Biomass CHP, small, backpressure (straw)
- Natural gas heat boiler, Biomass heat boiler (wood chips)
- Heat pumps
- Electric boilers
- Heat storages
- Transmission capacities between power regions

Data on capacities, efficiencies, operation costs, and technical lifetimes etc. for existing units for power/heat production, storage and transmission are included in the model. Gradual decommissioning of existing power/heat production capacities towards 2030 is thus taken into account. The optimisation is based on socio-economic costs in order to investigate how EVs would affect the power system in the absence of taxes, tariffs and subsidies. The idea behind this approach is that if the outcome does not correspond to what is desired for society, taxes, tariffs and subsidies can then be designed in order to reach the situation wanted.

## 9.2 Results

In the following, the results are shown covering the effect of EVs on power system investments, electricity generation, CO<sub>2</sub> emissions and costs.

### Effects on power system investments

Socio-economically optimal investments in new power production capacities generated by the model in the Base and EV scenario are illustrated in Figure 67 for each of the five countries. As shown, the investments cover on-shore and off-shore wind power, coal based CHP, nuclear power where this option is allowed, and open cycle gas turbines (OC-GT); the latter for ensuring sufficient capacity to cover peak loads.

As a result of increasing fuel and CO<sub>2</sub> prices, the economic conditions for wind power generally improve over the period. This is clearly illustrated for the cases of Denmark, Germany, and Sweden where wind power investments only or mainly occur in the last part of the period towards 2030. Furthermore, existing wind power capacities in Denmark and Germany are significantly decommissioned from 2020 to 2025 (from around 3,200 MW to 0 MW in Denmark and from around 23,000 MW to 11,000 MW in Germany). This is likely part of the explanation for the large wind power investments occurring in these countries in 2025. Norway, Sweden, and Finland, have relatively high onshore wind power resources in terms of obtainable full load hours<sup>1</sup>. Therefore, wind power investments occur earlier in these countries than for the cases of Denmark and Germany.

---

<sup>1</sup> Assumed full load hours for onshore wind power: Norway: 3000 [99.1, 99.2], Finland, Sweden: 2600 [99.1] and based on [99.3], Denmark, West: 2440, Denmark, East: 1960[99], Germany: 1750 (based on [99.4, 99.5] ).



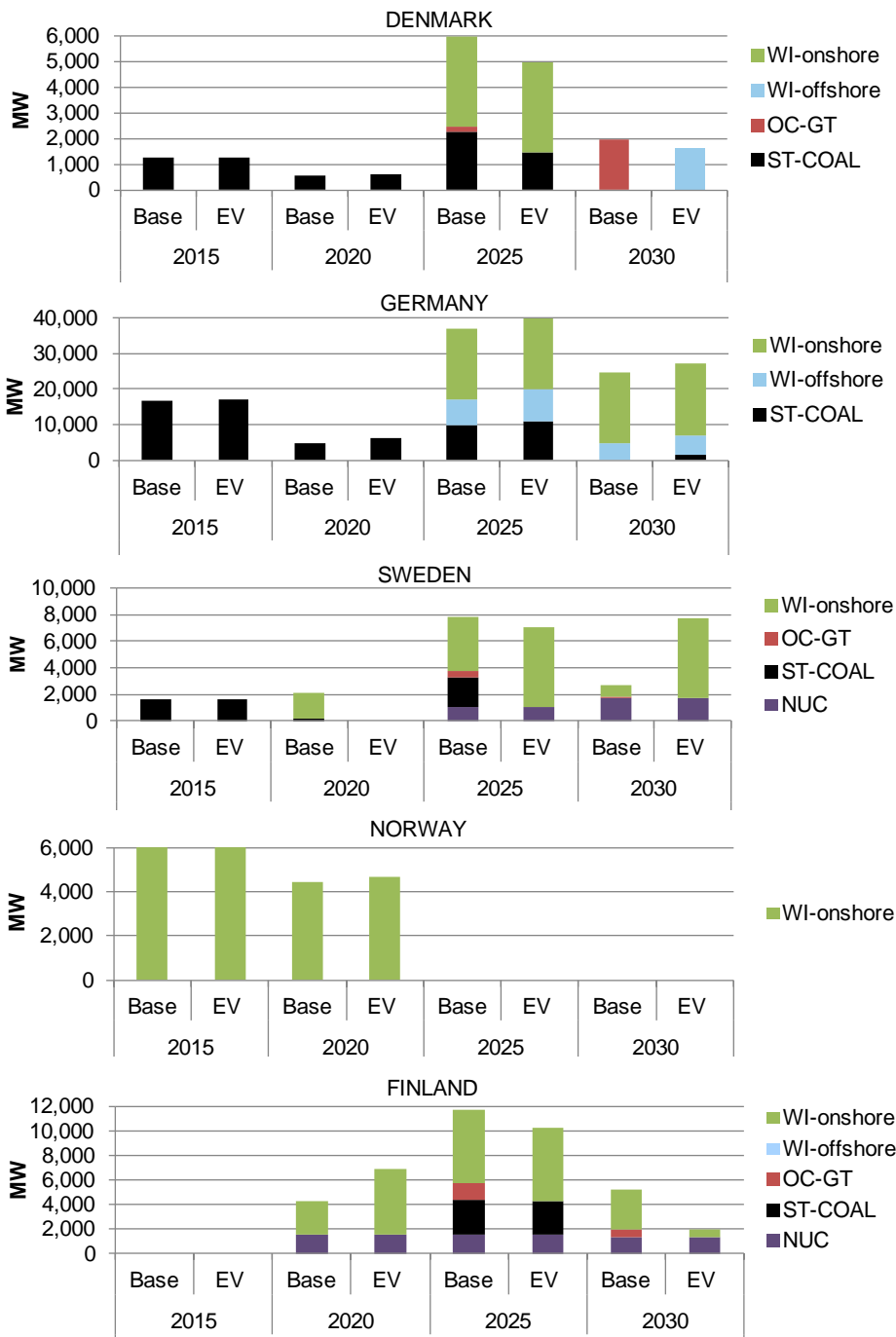

Figure 67. Investments in power production capacities in the Base and EV scenario, representing accumulated investments over each five year period. E.g. investments in 2020 represent accumulated investments from 2016 through 2020. WI: Wind power; ST-COAL: Steam turbine, extraction, coal; OC-GT: Open cycle gas turbine; NUC: Nuclear power.

Comparing the Base scenario with the EV scenario, it can be seen that the gradual implementation of EVs facilitates increased wind power investments in all five countries. The reason is that the flexible charging/discharging of EVs supports the integration of the variable production from wind power into the power systems. For Norway and Finland, this effect is observed from 2020, where EVs comprise 15 % of the vehicle fleet. As such, e.g. Finnish wind power investments are doubled in 2020 with the implementation of EVs. At higher EV

fleet shares of 34 % in 2025, EVs generate increased wind power investments in Germany and Sweden and in 2030, where EVs comprise 53 % of the vehicle fleet, increased wind power investments are observed in Denmark and Germany, and particularly in Sweden where wind power investments are increased manifold. In Finland, the assumed onshore wind potential is reached in 2030 in both scenarios. Hence, in this case the EVs push forward the investments in wind power. The Danish wind power investments in 2025 are made in Western Denmark where wind resources are highest. The wind power investments generated in the EV as well as in the Base scenario are constrained by the onshore wind potential for this area (set to 3,500 MW). As a result, identical wind power investments are observed for the two scenarios. In 2030, the effect of EVs on Danish wind power investments is, however, significant, increasing offshore wind power investments from 0 MW to around 1,600 MW. In the EV scenario, the accumulated Danish wind power capacity in 2030 is around 5,100 MW, i.e. significantly lower than the national medium/high wind target for 2030 of 7,300/8,000 MW [98]. As such, the results suggest that a large scale implementation of EVs is not sufficient to facilitate reaching the Danish wind target for 2030 by socio-economic optimality.

As a consequence of the large-scale EV implementation and resulting increase in electricity demand, one might expect a significantly increased need for dispatchable power production capacity. However, the results show that when EVs are charged/discharged intelligently, increased investment in dispatchable power production capacity is only observed in a few cases (Germany in 2020-2030). In fact, rather than increasing investments in thermal production capacity, EVs result in a reduced need for new thermal power capacities for the case of Denmark, Finland, and Sweden. As such, investments in open cycle gas turbines and/or coal CHP capacities are reduced significantly in these countries in 2025-2030 with the implementing of EVs. This is explained by the V2G capability of EVs contributing in covering peak loads. In Denmark, the effect is most significant in 2030 where investments in open cycle gas turbines are reduced from around 2,000 MW to 0 MW.

### **Effects on electricity generation**

By observing electricity generation in the EV scenario relative to generation in the Base scenario, it can be seen how electricity for EVs is produced in the optimisation (see Figure 68). As shown, the electricity demand for EVs is in Denmark largely covered with coal based electricity production in 2015 and 2020. The production increase occurs almost exclusively on existing plants, since the increase in Danish coal power investments caused by EVs is diminishing (cf. Figure 67). From 2025, Danish electricity demand for EVs is partly met by biomass based power production. This is a consequence of the increasing CO<sub>2</sub> prices and the relatively large increase in fossil fuel prices compared to biomass prices over the period. In 2025, electricity demand for EVs in Denmark is partly met by reducing electricity export to Germany and Sweden. This explains the gap in 2025 between the increase in power generation and the electricity demand for EVs. In 2030, EVs in Denmark generate a significant increase in wind power generation. This is a direct consequence of the increased wind power investment in the EV scenario compared to the Base scenario; i.e. only by increasing wind power capacities, EVs can result in increased wind power generation. The generated increase in Danish wind power production in 2030 is much higher than domestic electricity demand for EVs. As a result, significant displacement of coal based power production occurs and net electricity import from Norway and Sweden is reduced.

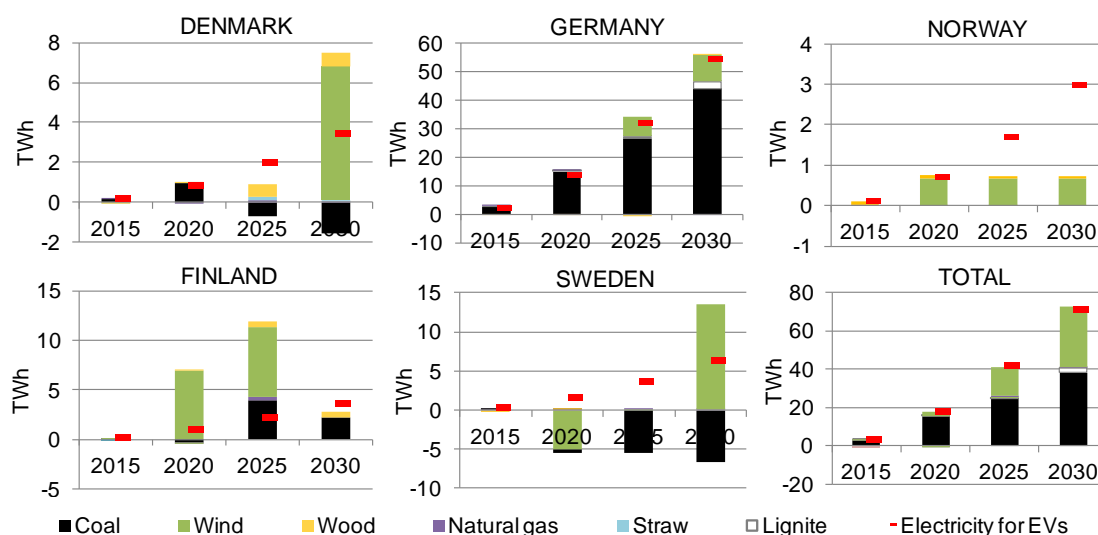

Figure 68. Changes in annual electricity generation due to implementation of electric vehicles. Due to import/export, possible changes in electricity consumption for heat pumps/electric boilers, and in the use of pumped hydro electricity storage, generated power increases in each year will not necessarily correspond to the electricity demand for electric vehicles.

The German case shows similarities with the Danish in the sense that electricity demand for EVs is in 2015-2020 largely met by increased coal based power production while wind power does not contribute in providing electricity for the EVs until in the last part of the period. Also in Sweden, EVs do not facilitate increased wind power generation until 2030. The Finnish case stands in contradiction the trend in Denmark, Germany and Sweden. As such, EVs in Finland generate increased wind power production from 2020 until reaching the assumed onshore wind potential. After that point, the electricity demand for EVs in Finland is largely met by coal fired electricity production. However, estimating the Finnish onshore potential is connected with large uncertainty and the potential might be higher than assumed. If setting the onshore wind potential higher, electricity for Finnish EVs would in the optimisation, also in the last part of the period, most likely be met by wind power. Norway is a large net electricity exporter and to a large extent, the cheapest way of providing electricity for EVs is therefore to reduce the export. Similarly, in 2020-2025 Sweden largely provides electricity for EVs by cutting down export. For this part, the implementation of EVs in Norway and Sweden, thus contributes to the generated increases in power production observed in the other countries.

## CO<sub>2</sub> emissions

As result of the EV implementation, Danish CO<sub>2</sub> emissions from the power, heat and transport systems modelled, are more or less unchanged in 2015-2020 while significant emission reductions are obtained in 2025, 7 %, and in 2030, 17 % (see Figure 69 a). The most important factors behind the significant improvement in the CO<sub>2</sub> balance over the period are 1) the increasing share of renewable energy in the electricity mix for EVs, 2) the gradual improvement in the efficiency of the EVs and 3) the increasing shares of EVs in the fleet. As illustrated in Figure 69b, the emission reductions in 2025 and 2030 are mainly caused by displaced fuel consumption for ICEs. In addition, an emission reduction from power&heat production is observed in 2030. This is an effect of the significant displacement of coal based power production that year (cf. Figure 68).

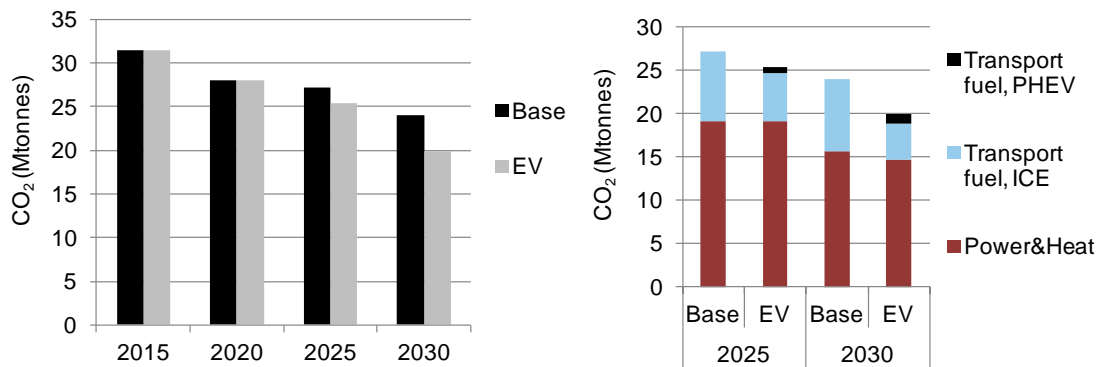

Figure 69 a). Danish CO<sub>2</sub> emissions for the simulated power, heat and transport system in the Base and EV scenario. b) Danish CO<sub>2</sub> emissions in 2025 and 2030, divided on sources for the two scenarios.

For the five Northern European countries as a whole CO<sub>2</sub> emissions are also more or less unchanged in 2015-2020 while reductions of 3 % and 7 % are obtained in 2025 and 2030.

### Costs

Figure 70 shows that the implementation of EVs results in an increase in total costs for the simulated power, heat and transport sector of the Northern European countries; around 1.5-7.1 €Billion/yr depending on the year, corresponding to increases of 0.8-3.9 %.

The cost increase is partly due to larger investment costs per vehicle for BEVs and PHEVs compared to ICEs. Moreover, due to the assumed lower annual driving of BEVs compared to ICEs, a larger amount of BEVs are required to provide the same transport demand. Overall, this increases total investment and O&M costs for the transport sector. As illustrated in Figure 70b, the cost reduction from displacing fuel consumption in ICEs is not enough to compensate for this. The cost increase is highest in 2020 (3.9 %) and then lower in 2025 (1.2 %) and 2030 (0.8%); reflecting the influence of expected technical and economic improvements of EVs over the period.

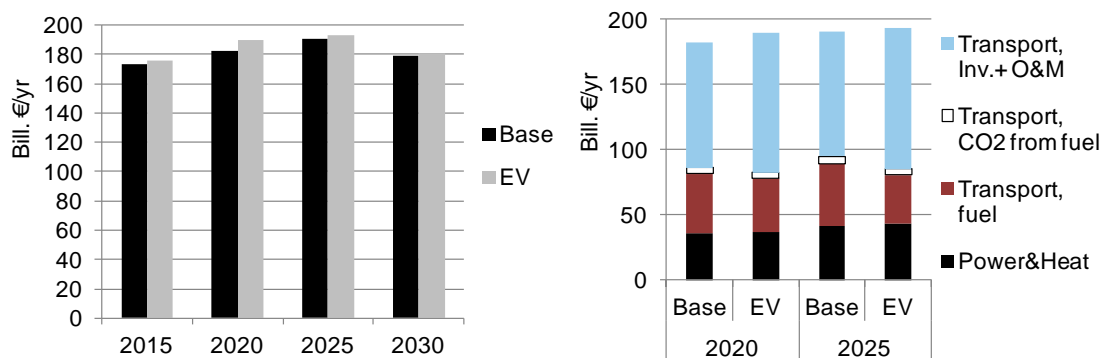

Figure 70 a). Total costs for the simulated power, heat and transport system for the Northern European countries in the Base and EV scenario. b) Total costs in 2020 and 2025, divided on sources.

These cost effects are based on an assumed implementation of PHEVs as well as BEVs while it should be mentioned that PHEVs alone have, in [93], shown to provide system cost reductions. Furthermore, potential benefits from using EVs for providing regulating power and power reserves is not included in the cost estimates. Finally, the socio-economic benefit of reducing the transports dependency on oil, increasing security of supply, is not valued.

When relating the cost increases (excluding CO<sub>2</sub> quota costs) to the CO<sub>2</sub> emission reductions provided by EVs, average CO<sub>2</sub> reduction costs for EVs can be estimated for the five countries as a whole. This shows that CO<sub>2</sub> reduction costs are reduced manifold over the period; from very high levels of around 7100 €/ton in 2015 and 1500 €/ton in 2020, to 110 €/ton in 2025 and 80 €/ton in 2030. However, even in 2030, the CO<sub>2</sub> reductions costs for EVs are rather high compared to the expected CO<sub>2</sub> price level of around 39 €/ton [95]. As such, when comparing with assumed CO<sub>2</sub> price levels, the analysis suggests a low cost efficiency of EVs in providing CO<sub>2</sub> reductions, particularly in the short term.

## Sensitivity analysis

In the analysis above, based on [95], CO<sub>2</sub> prices are assumed to increase from 20€/ton CO<sub>2</sub> in 2015 to 39 €/ton CO<sub>2</sub> in 2030, and the assumed fuel prices correspond to an oil price of \$88/barrel in 2015 and \$117/barrel in 2030. In a sensitivity analysis, the following low/high fuel price and low/high CO<sub>2</sub> price developments are assumed:

- Fuel prices: set to low at \$80/barrel in 2015 increasing linearly to \$90/barrel in 2030 and at high increasing linearly from \$80/barrel in 2010 to \$95/barrel in 2015 and \$140/barrel in 2030. Ratios between prices on different fuels are kept constant and are based on [95].
- CO<sub>2</sub> prices: set to low at 15 €/ton in 2015 increasing linearly to 20 €/ton in 2030 and at high increasing linearly from 14 €/ton in 2010 to 26 €/ton in 2015 and 60 €/ton in 2030.

These analyses show that also at low/high fuel and low/high CO<sub>2</sub> prices, EVs facilitate a reduced need for new coal/natural gas production capacities in several of the countries, including Denmark. However, changes in investments and electricity production caused by the EVs over the period are generally found to be sensitive to the development in fuel and CO<sub>2</sub> prices. As such, e.g. for Denmark, at the low fuel price conditions, wind power is not included in the electricity mix for EVs towards 2030. At the low CO<sub>2</sub> price conditions, onshore wind power investments in the Base scenario are reduced below the onshore potential for Western Denmark. As a result, EVs facilitate an increase in onshore wind power investments in 2025. However, no offshore wind power investments are observed and in 2030, wind power only contributes with a small part of the electricity for EVs. Overall, at the low fuel/CO<sub>2</sub> price conditions, electricity demand for EVs in Denmark is in most of the period towards 2030 largely covered by coal based power or through electricity exchange. When assuming high fuel or CO<sub>2</sub> prices EVs facilitate considerable increases in wind power investments from 2025, i.e. five earlier than at the original price conditions. The resulting reductions in Danish CO<sub>2</sub> emissions depending on price conditions are presented in Table 1.

*Table 1. Change in Danish CO<sub>2</sub> emissions reductions due to implementation of EVs depending on fuel and CO<sub>2</sub> price conditions*

	2015	2020	2025	2030
Fuel and CO <sub>2</sub> prices based on [95]	0.04%	-0.1%	-7%	-17%
Low fuel prices	-0.5%	-0.4%	-6%	-15%
High fuel prices	-0.2%	-2.0%	-14%	-22%
Low CO <sub>2</sub> prices	-0.4%	-1.1%	-9%	-10%
High CO <sub>2</sub> prices*	0.1%	-0.8%	2%	-20%

\* The slight CO<sub>2</sub> emission increase in 2025 in the high CO<sub>2</sub> price scenario is due to reduced net import, resulting in increased coal based power production in Denmark. Cf. Figure 61 which illustrates the diverse reactions in different countries. For the five considered countries as a whole, CO<sub>2</sub> emissions are in 2025 reduced with 6 % in this scenario.

### 9.3 Conclusions

- When charged/discharged intelligently electric vehicles (EVs) can facilitate increased wind power investments and can due to vehicle-to-grid capability reduce the need for new coal/natural gas power capacities
- Wind power will likely provide a large share of the electricity for EVs towards 2030 in several of the Northern European countries
- However, if not followed up by economic support for renewable energy technologies other than CO<sub>2</sub> quotas, wind power will, for the case of Denmark (and Germany and Sweden) not contribute in providing electricity for EVs until the last part of the period
- As a result, electricity demand for EVs will in Denmark (and Germany) in the short term likely be met by coal based power
- Large scale implementation of EVs is not sufficient to facilitate reaching the Danish wind target for 2030 by socio-economic optimality
- Effects of EVs on the power system vary significantly from country to country and are sensitive to variations in fuel and CO<sub>2</sub> prices
- In the last part of the period towards 2030, EVs can provide significant CO<sub>2</sub> emission reductions for the Danish energy system as well as for the Northern European countries as a whole.

## 10 Wilmar model results – EVs and the value of smart charging

The charging of electric vehicle batteries without any control is likely to result in a new peak in electricity demand during the late afternoon. The new peak could be avoided and the shape of electricity demand flattened with optimized timing of the battery charging, e.g. smart charging. Smart EVs could also bring other benefits to the power system by participating in ancillary services. In contrast, dumb EVs will start charging immediately after plugging in and would keep charging until their batteries are full. This work calculates the value of smart charging by comparing the investment and operational costs of model runs with EVs charging behavior being dumb versus EVs with charging/discharging behavior being smart. The analysis is performed on the power system of Finland in 2035 with one million EVs half of them being battery electric vehicles (BEVs) and half being plug-in hybrid electric vehicles (PHEVs). It is documented in full in [102].

This work generates results by using the Wilmar model in combination with the generation planning model Balmorel. The Wilmar and the developed EV model in Wilmar are shortly presented in Chapter 8.. Balmorel takes into account that as the demand curve changes, the investment patterns into power plants will also change. This in turn will influence the total cost of the power system. The EV modelling used in Balmorel in this work is documented in [102]. Furthermore, increased demand-side flexibility will make investments in base load or variable production more competitive against intermediate and peak production plants. Up and down regulation of power production due to load and wind power forecast errors take place in Wilmar. Hence, it can quantify the value of EVs providing the needed flexibility to cope with the partial predictability of load and wind.

An important benefit of smart charging versus dumb charging is that smart charging can decrease the need for reinforcements of the distribution grids as seen in an analysis for Denmark [101]. This effect is not included in the results reported here.

### 10.1 Scenarios

The purpose of the scenario runs was to examine the impact of various assumptions about the behavior of the electric vehicles and their use in the power system. By comparing different scenario runs the benefits due to smart charging could be split into benefits due to the ability to provide spinning reserves (primary and secondary reserves in the terminology of the UCTE grid code), providing non-spinning reserves and intra-day flexibility by up and down regulation of charging and discharging schedules determined day-ahead, and being able to make an optimal day-ahead schedule for the charging and discharging.

The analysis is performed on the power system of Finland in 2035 with one million EVs half of them being BEVs and half being PHEVs. The Finnish system gets about 10% of its production from hydropower, with most of it being controllable. Finland is a northern country where heating is required during the winter. The country has many combined heat and power

units for district heating. The model includes three heating areas for Finland, all of which have to fulfill their heating requirements separately. Large portion of the power plants were retired by the study year of 2035. Notable exceptions are 2440 MW of nuclear capacity, 1310 MW<sub>el</sub> of natural gas capacity, all the hydro power plants and 2030 MW<sub>el</sub> of industrial back pressure power plants using wood waste from industrial processes.

Scenarios were compared against the base scenario. The base scenario uses the power plant portfolio from Balmorel smart EV scenario, which is described in [102]. As we wanted the base scenario to have a high share of installed wind power, the wind power investment costs were set to 0.8 million EUR per MW. This is significantly lower than the estimate of 1.22 million EUR per MW in the technology data document from Danish Energy Agency and Energinet.dk [103] i.e. it represents an optimistic estimate of the future wind power costs. In the base scenario, departing EVs had to have full batteries and they were charged and discharged in optimal manner from the system perspective. Grid-connected EVs were able to provide reserves for the power system and all of them were capable of V2G. In addition, 10% of PHEVs were capable of E2G (engine-to-grid). Dumb EVs start charging when they are plugged in and stop charging once they are full and they cannot provide reserves.

EVs capable of V2G can discharge their batteries to the grid, but there has to be an economic incentive for this to happen. In the modelling context, it was assumed that the cost of wear and tear on the batteries for the extra use is 10 €/MWh, and the roundtrip efficiency is 85%. There has to be a corresponding difference in power price fluctuations before the use of V2G for peak levelling is economical. Another use of V2G is the provision of the ancillary services. EVs with V2G could be especially useful as disturbance reserves<sup>2</sup> since these are rarely actually used, but the capacity has to be online. It was assumed that it does not cost anything extra to have the capacity online when the vehicles are plugged in. Therefore, more expensive sources of reserve capacity were replaced by the EVs.

EVs will increase the electricity consumption and change the profile of the consumption. Four different situations are therefore analysed in terms of generation investments: no EVs, dumb EVs, smart EVs, and smart EVs without a capacity adequacy contribution (No 500). All of these will have induced a somewhat different power plant portfolio given enough time. The analysis tries to capture this by using a generation planning model (Balmorel) to estimate the different power plant portfolios. Two of the portfolio scenarios (no EVs and smart EVs) are borrowed from another article [102] and the details of the model assumptions and portfolios can be seen there.

In the smart EVs scenario of Balmorel, the 1 million EVs were considered to contribute to the power system capacity adequacy with 500 MW. The low electricity storage capacity of the EVs will limit the length of the production period and they cannot be trusted to provide energy for prolonged periods. For the smart EV scenarios in Balmorel, it was assumed that one hour of non-spinning reserves could be maintained at the 500 MW level. In terms of capacity only, a V2G share of about 20% could provide 500 MW from the plugged-in vehicles during the highest net load hours. This 500 MW decreases the need for additional power plant capacity in the generation planning model. For comparison 500 MW of open cycle gas turbines would have an annuity of 16.3 M€/year in the model runs. In principle, the capacity effect could be

---

<sup>2</sup> Also known as contingency reserves or automatic frequency control reserves, which activate automatically following a fault in the system, if the system frequency drops below a certain threshold.



assumed higher, if more EVs had V2G. In the WILMAR runs, it was possible to require the EVs to have enough stored electricity to provide the reserve for at least an hour.

Power Plant Type	MW of Electricity			
	No EVs	Dumb	Smart	No 500
NatGas comb. cycle cond.	363	520	16	16
NatGas open cycle cond.	2861	3580	2519	3024
Nuclear	5312	5688	5312	5312
Wind	4705	5130	6122	6122
Forest residue CHP	1203	1206	1196	1192
Wood waste CHP	76	73	73	75

*Table 2. Capacity of New Power Plants in the Different Balmorel Scenarios. No EVs designate a Balmorel run without EVs, “Dumb” designate a Balmorel run with 1 million EVs being charged in a dumb manner. “Smart” designate a Balmorel with 1 million EVs being charged/discharged in a smart manner. “No 500” designate a “Smart” Balmorel run without the EVs delivering peak load power by V2G i.e. the 500 MW contribution of EVs to the capacity balance restriction is removed in the “No 500” scenario.*

Table 2 shows the differences in the power plant portfolios created by the Balmorel runs. The smart EVs reduce the need for power plant capacity through the timing of the charging as compared to their dumb-charging counterparts, since the dumb EVs create a new peak in the net load. The difference in the peak demand was 544 MW (in the Wilmar scenarios). The flexibility of smart EVs induced a larger proportion of variable wind power production, whereas inflexible dumb EVs leaned more on adjustable conventional power plants.

## 10.2 Results

Wilmar analyses only operational costs and does not include investment costs. These are estimated from the aforementioned Balmorel runs. The investment costs for new power plants required by the year under study, 2035, were 2.29 billion Euros in the scenario with smart EVs. This was 91 million Euros more than the investment costs in the scenario without EVs. This indicates that in the longer term, EVs attract more costly power plant investments, which in turn decrease the operational costs of the system. The overall result is lower average cost for electricity when the consumption from the EVs is factored in. In contrast, dumb EVs will increase the average cost of electricity.

There are differences between the two model setups, and the cost differences are therefore only indicative. As expected, the more detailed Wilmar reveals costs that the Balmorel was unable to capture. With the smart EVs, these hidden costs are smaller, even though there is a higher share of variable wind power production in the smart EVs scenario. The smart EVs help the system to operate in a more efficient manner.

The difference in the sum of operational costs calculated with Wilmar and investment costs calculated with Balmorel between no EVs and dumb EVs gives the additional costs of providing necessary electricity for the EV fleet. The difference between smart and dumb EVs gives the benefit of allowing the vehicle charging and discharging to be controlled in

accordance with the market conditions. This benefit has to be shared between the vehicle owners and an entity that controls the charging in keeping with the market conditions and the needs of vehicle owners. It is not considered how the benefits are shared; only the magnitude of the benefits in different conditions are estimated. PHEVs will have additional costs due to fuel use when using the engine. As the PHEV fuel usage does not change, these costs were not considered.

The annual benefit of smart EVs compared with dumb EVs is used as a metric for the results. The operational model (Wilmar) is used to estimate the operational costs and the costs for annualized power plant investments and fixed costs are taken from the difference between the generation planning model runs (Balmorel). The annualized investment costs and the fixed costs for the smart EVs scenario were 102 M€/year less expensive than in the dumb EVs scenario. As there are one million EVs in the scenarios, this means 102 €/vehicle/year. The investment and fixed costs for the smart EVs scenario were 106 M€/year more expensive than the scenario without EVs. These costs are included in the numbers presented later in this section.

The results from the Balmorel runs are rather different. The main reason is that units are simplified and more aggregated compared to the Wilmar runs. The benefits of smart EVs are smaller in Balmorel runs, since the units do not have minimum operation limits or part-load efficiencies, which create additional costs that the smart EVs could reduce.

### **Sources of benefits from smart EVs**

The system benefit of smart EVs compared to dumb EVs was 227 €/vehicle/year in the studied system (see Figure 71). Some of the benefits come from less expensive operations and some come from smaller investment and fixed costs. To see the benefit of EVs in the spinning reserves, the base scenario was compared with a scenario where the EVs were not able to provide spinning reserves ('No Spinning'). The provision of spinning reserves benefitted 38 €/vehicle/year (17%). The model calculates only the reservation of the capacity and not the actual use. Intraday flexibility means that the EVs were allowed to correct the forecast errors in wind and load by up and down regulation of the charging and discharging schedules determined day-ahead. The benefit of intraday flexibility (47%) was calculated by comparing a scenario where the EVs were not flexible in the intraday ('No Flexibility') with the scenario 'No Spinning'. The 'No Flexibility' WILMAR scenario used a power plant portfolio based on the BALMOREL scenario where the EVs did not contribute to the power system capacity adequacy as reserves (scenario "No 500" in Table 2), because they are not able to provide non-spinning reserve without intra-day flexibility. Day-ahead planning benefits (36%) are due to the more economic charging/discharging pattern decided day-ahead before the intraday adjustments. This was calculated by comparing the 'Dumb' scenario with the 'No Flexibility' scenario.

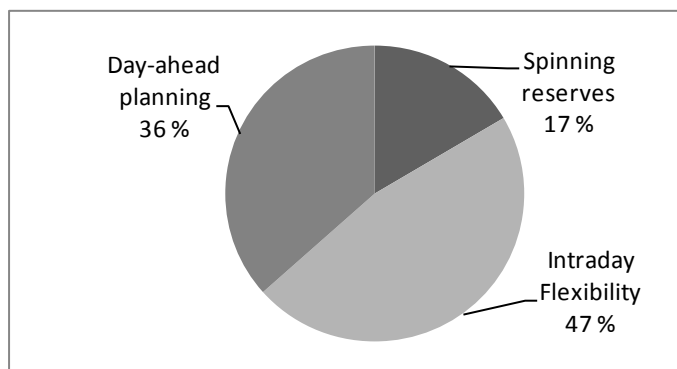

Figure 71. The division of the benefit from smart EVs over dumb EVs between different components. The total benefit was 227 €/vehicle/year.

The model does not analyse intra hour load following or regulation, and possible benefits from these are missing from the analysis. Due to the availability of flexible hydropower and open cycle gas turbines the model was able to reserve the capacity for non-spinning reserves without extra cost at all times, and therefore EVs did not create cost savings for the provision of non-spinning reserves.

### Benefits of Vehicle-to-Grid

The benefits of the V2G mostly derive from the provision of the reserves. Furthermore, most of the benefits can be achieved by having only a portion of the EV vehicle fleet capable of V2G (Table 3). This suggests that it does not make sense to equip all EVs with the V2G, because V2G capability will incur extra costs in the vehicles and in the grid connection. With E2G, 10% of the PHEVs (5% of all EVs) were assumed to have E2G. For most vehicles it is not possible to let the grid-connected car engines start by themselves when the power grid could use the power or the capacity. All the V2G scenarios were run with the same power plant portfolio based on the ‘smart’ Balmorel scenario. Balmorel was able to use the V2G, but not the E2G. The cost of the ‘No V2G’ scenario in the Table IV should be lower, if the power plant portfolio was separately optimised for smart EVs without V2G.

Scenario	Cost over Base (€/vehicle/year)
No V2G	53
V2G Half of the vehicles	6.7
V2G half, no E2G	8.0
Battery not full	0.4

Table 3. Cost of scenarios compared to the base scenario, in which V2G was fully allowed.

In the ‘battery not full’ scenario of Table 3, V2G was fully allowed, but the EVs were not required to have completely full batteries when leaving the grid. BEVs had to have at least

80% full batteries and PHEVs at least 50% full batteries. The supposed benefit of this additional flexibility was lost within modelling inaccuracies.

### Market prices

The analysis so far has concentrated on the system costs, which means that all the costs of running the system have been summed up. Another perspective is to look at the prices at the electricity markets (day-ahead and short-term markets). This reflects what the electric vehicle owners will have to pay for their electricity consumption. The costs here are based on the marginal cost of the model. If the market functioned perfectly and the cost assumptions were correct, the marginal cost should be the same as the market price. In reality, market prices are very likely to be at least somewhat higher. Furthermore, market prices are very sensitive to the actual capacity balance in the system. When there is a shortage of capacity, power plants with very high marginal costs need to be used more and the average market price can be much higher than if plenty of spare capacity existed.

In these model runs, the capacity balance is tight, since the generation planning model has invested in just enough capacity to cover for the worst situation plus some reserve margin. In reality, there could be too much or too little capacity due to investment uncertainty in combination with long building times.

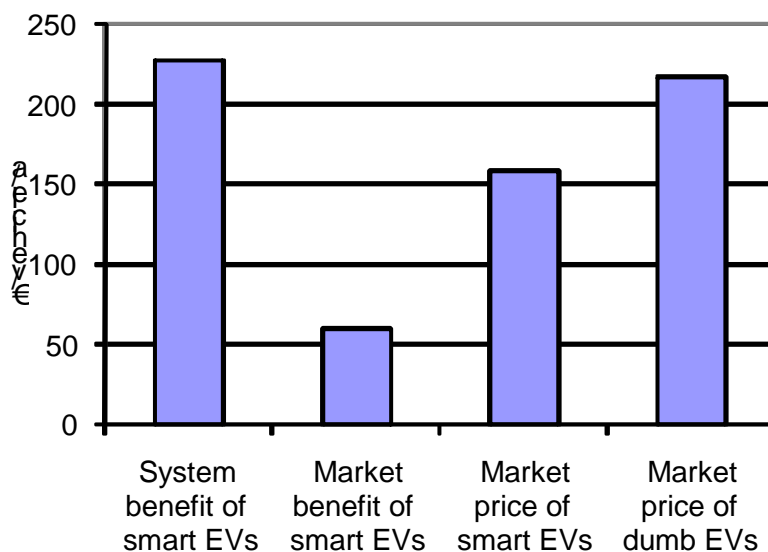

*Figure 72 Market benefits and prices of smart and dumb EVs. Market price of smart and dumb EVs is the sum of hourly market prices for charging the EVs in these scenarios. This includes revenue from discharging in the smart EVs scenario. Market benefit of smart EVs is the difference between the dumb and smart scenarios.[€/vehicle/year]*

Figure 72 shows the results concerning market prices. The cost to buy electricity for smart EVs from the electricity markets was 157 €/vehicle/year. This takes into account the purchase of electricity for charging the battery as well as the sale of electricity by discharging or engine power. It does not take into account the sale of spare capacity as spinning reserve. If the

shadow price of the equation requiring enough spinning reserves is taken as the market price for spinning reserves, then the sales would yield 1.7 €/vehicle/year.

### **CO<sub>2</sub> emissions**

There has been considerable interest in the future CO<sub>2</sub> emissions from the electric vehicles. For conventional vehicles it is relatively straightforward to calculate the emissions from the use of the vehicles. It is not so with the electric vehicles. The authors believe it would be misleading to assess marginal emissions in a long-term study, since emissions due to EV electricity consumption should not be more marginal than any other electricity consumption in the long term. It would be more appropriate to use average emissions. Based on the scenario results, the average emissions in 2035 were 29.2 kgCO<sub>2</sub>/MWh in the dumb EVs scenario and 26.0 kgCO<sub>2</sub>/MWh in the smart EVs scenario. This would result in CO<sub>2</sub> emissions of 104-117 kgCO<sub>2</sub>/vehicle/year for BEVs. PHEVs would have larger emissions, since they will also use fuel when driving. In comparison, a future hybrid vehicle with specific emissions of 90 gCO<sub>2</sub>/km and annual driving distance of 20 000 km would cause emissions of 1800 kgCO<sub>2</sub>/vehicle/year. The large difference between BEVs and regular hybrids is due to the very low carbon intensity of electricity production in the model scenarios. This was a result of the CO<sub>2</sub> price, which caused minimal investments in power generation with CO<sub>2</sub> emissions.

However, there is another relevant approach. It is a comparison between the scenario where there was no EVs and the scenarios where there are EVs. The changes in the emissions of the whole power system can be seen as a consequence of the introduction of the EVs. In the case of dumb EVs, this change was +169 kgCO<sub>2</sub>/vehicle/year. In the case of smart EVs, the change would be -211 kgCO<sub>2</sub>/vehicle/year. The smart EVs would make the power system emit less CO<sub>2</sub> by enabling a higher share of CO<sub>2</sub> free production (wind and nuclear).

### **10.3 Conclusions**

The analysis has estimated two extremes of EV charging intelligence and how these might influence the total costs of an optimised future power system. The methodology employed brings rigor to the way the costs should be estimated. The results of the work demonstrate that it is not enough to assess operational costs - also impacts of the new consumption patterns in the development of the long-term power plant portfolio should be taken into account. In the estimation of operational costs, stochastic model with binary unit commitment decisions was used to achieve more accurate results compared to previous studies.

The results exclude grid and intra hour balancing related costs and benefits. Furthermore, the restrictions in the use of the flexibility of the smart EVs are not as binding as they are likely to be in the real life. This includes the omission of uncertainty in driving behaviour, although the model had a safety margin for filling up the batteries.

In the case of smart EVs, the system cost to charge an electric vehicle calculated as the difference in the sum of investment costs and operational costs between the smart scenario and the No EV scenario was around 36 €/vehicle/year. In the case of dumb EVs the system cost was around 263 €/vehicle/year. Depending on the share of smart EVs vs. dumb EVs, the realised average cost should fall between these extremes – excluding the uncertainties in the results. Most of the benefits come from the smart timing of charging. This can be divided

between the benefits accrued on the day-ahead planning phase and the intraday adjustments to mitigate the forecast errors of electricity demand and variable generation.

## 11 Conclusions and Discussion

The following summing up of conclusions from the analyses will focus mainly on the longer term consequences, - year 2030.

The system analysed in year 2030 is characterised by

- *a transport sector*  
where the use of electric vehicles (EVs) is *assumed* to have developed to make up well 50 % of the Danish and European road transport segment:  
Passenger cars + light commercial vehicles (LCV) of weight < 3.5ton,  
and
- *a power sector*  
where *interaction* with electricity based segments of the transport sector (via evolved EV fleets) strongly may have impacted its development.

Generally the scenario analyses presented look at *differences* emerging when the assumed 'business as usual' scenario, or reference development scenario, is compared with set up alternative scenarios.

Analyses related to such system development towards year 2030 have been carried out at different levels, and different aspects have been in focus. The analyses concern:

### **Transport sector aspects:**

- Electric vehicle (EV) and conventional vehicle (ICEV) developments assumed
- Potential EV fleet developments

### **Power sector and grid aspects:**

- Vehicle - grid connection and interaction issues
- Distribution grid – EV fleet interaction
- Transmission grid – EV fleet interaction

### **Overall transport and power system aspects:**

- EV fleet and overall power system development / investment impacts
- EV fleet and overall power system interaction and operation

Conclusions drawn forward from the chain of analyses carried out will mainly address consequences for the energy consumption, and energy substitution (in type, and from fossil towards renewable resources), and the CO<sub>2</sub> emission consequences. Furthermore, the economic consequences for society at large are addressed. The main question asked is how the scenarios set up perform relative to overall (political) aims related to the security of energy supplies, energy economy, environment and climate.

### **Transport sector aspects:**

#### **EVs substituting ICEVs in road transport (Chapter 3)**

EVs, such as plug-in hybrid electric vehicle (PHEV) or battery electric vehicle (BEV), substitute gasoline and diesel with grid electricity. Thus, EVs diversify the transport sector energy resource base, and reduce the present dependency on oil.

The EV drive trains furthermore have potential for being very energy efficient. About 3000 kWh of electricity may sustain 20.000 km average EV driving. Via the corresponding conventional ICEV this would require about 10000 kWh of gasoline/diesel.

CO<sub>2</sub> emissions relate to the power supply system charging the EVs, and the EV footprint of the individual vehicle will change in accordance with the power supply. EVs bring insignificant CO<sub>2</sub> reduction if the charged electricity is coal dominated *marginal* power production in the Danish 'reference' case development. However, assuming *average* power supply characteristics, and *linear descend to zero CO<sub>2</sub> emission in 2050* for the power supply, substantial CO<sub>2</sub> reduction is achieved via EVs substituting ICEVs. Ultimately EVs may provide zero CO<sub>2</sub> emission road transport. The individual ICEV of today may emit about 2-3 ton CO<sub>2</sub>/year. This equals maximal achievable EV CO<sub>2</sub> reduction in 'average' per vehicle.

Cost and lifetime of EV batteries much determine the EV economy. In a '*conservative scenario*' (COWI 2007) on the battery cost development PHEVs may break-even with the ICEV beyond year 2020 based on the socio-economic cost of ownership. However, in an '*optimistic scenario*' (USDOE 2010) on the battery cost development, the PHEV may break-even with the ICEV as early as year 2015, yielding an increasing surplus from then on. In such scenario the PHEV purchased in 2030 have surpassed the ICEV of the same vintage showing costs of ownership about 15% below the corresponding ICEV. Thus in both battery cost scenarios viz., the '*conservative*' and '*optimistic*' scenarios, the PHEV is expected to become the better choice from an economic point of view. The energy and CO<sub>2</sub>-emission consequences likewise points to the PHEV as the robust and better choice of the two. Future PHEVs can increase transport energy diversity and security of supplies, and PHEVs introduce large potentials for achieving CO<sub>2</sub>-emission reduction. Rising fuel costs and declining specific battery costs are main causes behind this development.

For the BEV, being more 'battery' intensive, break-even with the ICEV is postponed further into the future. In the '*conservative battery cost scenario*' this happens close to or beyond year 2030, and '*optimistic battery cost scenario*' break-even with the ICEV is reached before or about year 2020. And in both scenarios the BEV will eventually outperform the ICEV economically, due to the same fuel price and battery cost trends working in favor for the BEV as for the PHEV above. And as for the PHEV the BEV can contribute very favorable CO<sub>2</sub> emission reduction and energy diversity options to the road transport sector.

It must be emphasized that externalities and infrastructure costs are not included in this partial analysis. Most of the externalities identified and *not* taken into account tend to act in favor of the EV alternatives.

Potential CO<sub>2</sub>-emission costs savings are less important for the EV owner, even though the EV CO<sub>2</sub>-emission potential is very important for society at large. Seen relative to the total cost of vehicle ownership CO<sub>2</sub> emission costs are small. Therefore such costs are not likely to constitute an incentive for the choice of vehicle at purchase.

#### **EV fleet development substituting conventional ICEVs (Chapter 4)**

The EPRI 2007 assumptions [91] on the PHEV market development are used as basis for setting up EV scenarios corresponding to the Danish case. Relative market shares for the BEV and PHEV vehicles are furthermore based on the IEA Blue Map scenario from 2009 [92]. Market shares for PHEVs, starting low year 2011, is assumed to grow fast in the period 2015-2025 and reaches close to 50% in 2025. As consequence almost 40% of the vehicles on the road year 2030 in this fleet segment are PHEVs and EVs, PHEVs and BEVs, in total constitute well 50% of the fleet.

In such road transport scenario year 2030 the Danish PHEV fleet size numbers about 1.1 million vehicles. In '*net average*' this PHEV fleet will substitute about 9.0TWh<sub>fuel</sub>/year of gasoline/diesel when it is assumed that 77% of the annual driving is in *battery electric mode*. The remaining 23% of the driving is gasoline/diesel based where the PHEV is run in its *hybrid*



*electric mode*. Electricity substitutes the fuel, however, due to the very high PHEV energy efficiency when operated in *battery electric mode* only about 2.5TWh<sub>el</sub> of electricity will substitute 9.0TWh<sub>fuel</sub> (gasoline/diesel).

A concurrent BEV scenario assumes a Danish BEV fleet size of about 0.55 million vehicles year 2030. Including assumed BEV and ICEV efficiency developments and the composition of vehicles (split on different vintage groups) about 5.4TWh<sub>fuel</sub> is substituted by about 1.7TWh<sub>el</sub> that year.

The annual driving of an EV fleet of about 1.65 million vehicles year 2030 (or well 50% of the fleet segment composed of 1/3 BEVs and 2/3 PHEVs), may be sustained by 4.2TWh<sub>el</sub> plus about 2.7TWh<sub>fuel</sub>. Such EV fleet on the other hand substitutes of about 14.4TWh<sub>fuel</sub> gasoline/diesel otherwise used to fuel a corresponding fleet of ICEVs. The combined scenario set up increases the Danish electricity demand with approximately 4.2TWh<sub>el</sub> in total which, for comparison, amounts to approximately 12% increase of the present overall Danish annual electricity consumption.

The CO<sub>2</sub> emission depends on the power supply system charging the EV fleets. Numbers presented here are based on the assumption of a *linear descend to zero CO<sub>2</sub> emission in 2050* for Danish power supply. Furthermore, *average CO<sub>2</sub> characteristics* (on annual basis) for electricity charging the EV fleets has been assumed. Based on this the year 2030 PHEV fleet of about 1.1 million vehicles substituting ICEVs will reduce emission that year with about 1.8 million ton CO<sub>2</sub>. The year 2030 BEV fleet sized to about 0.55 million vehicles reduces emission with about 0.9 million ton CO<sub>2</sub> relative to the expected future ICEV fleet anno 2030.

As for the individual vehicle, cost and lifetime of EV batteries much determine the EV economy and the outcome of the PHEV and BEV scenarios.

Assuming the '*conservative battery cost scenario*' (COWI 2007) the PHEV scenario is close to break-even with the ICEV reference development. And beyond year 2025 annual socio-economic gains begin to emerge. For the BEV scenario, however, annual deficits are seen throughout the period, though getting relatively smaller later in the period.

In an '*optimistic battery cost scenario*' (US DOE 2010) the PHEV fleet development scenario is attractive from year 2015, and its annual surplus improves from then on. The BEV fleet development scenario becomes cost effective as well, though from beyond year 2020. These results are based on a partial socio-economic analysis *excluding externalities and transport-power sector interaction*.

Transport system robustness may be increased considerably via EVs due to the diversified energy resource basis in power systems. A new (but potentially less binding) dependency on electricity substitutes the present (close to 100%) oil dependency. Substituting oil furthermore contributes to hedging oil price rises (partly counteracting the EV-transition). Reduced costs of operating for EV based transport likewise make the transport system less vulnerable. And EV flexibility as to when to charge may stabilize and potentially reduce electricity market prices achievable.

Flexibility on the demand side of the power system improves the overall power system flexibility. This is important e.g. for integrating fluctuating power production, e.g. such as wind power, by lowering integration costs. And this may eventually bring along reduced CO<sub>2</sub>-emission to be inherited by an EV based transport sector.

Other (externality) gains for society at large are that the EV road transport scenarios bring along reduced local pollution and reduction of noise.

For the further analyses it has been assumed that battery costs are in accordance with or close to the so called '*conservative scenario*'. As mentioned above, this makes PHEV ownership costs of about break-even with the ICEV beyond year 2020, and the BEV break-even with the corresponding conventional ICEV of same vintage just beyond year 2030.

### **Power sector and grid aspects:**

#### **EV and grid interaction (Chapter 5)**

Important issues are the accessibility for EV's to charge from the grid and the reverse process of discharging electric vehicles back into the grid, termed V2G (Vehicle to Grid). Focus areas in this respect are the infrastructure and communication requirements.

The integration between the electricity grid and the EVs contains a number of challenges with respect to the details for the implementation, including standardisation issues. In particular this is the case when aiming to harvest the full potential benefits of V2G functionalities. A range of preconditions and details are essential for the positive and controlled integration of EVs with the electricity grids.

Controlled (or smart) charging requires a *control signal from the power system* to the EV or to the charging post. This control can either be centralised or distributed. Such control may make use of *dynamic power prices* which can be used for all types of smart control, including the V2G. On top of this an *appropriate payment scheme* between the EV user and the electricity supplier, including the distribution and transmission system operator (DSO and TSO) must be implemented.

Further work is needed in order to find appropriate solutions to the challenges.

#### **Distribution grid – EV fleet interaction (Chapter 6)**

The *home of the EV owner* is where the EV is likely to be charged very often. Home loads would typically have a point of common coupling *at the 0.4 kV level in Danish/European distribution grids*.

Distribution feeders (0.4kV) may serve consumers of different categories in a local area. Therefore it is difficult to say in general how charging of EVs will affect total loading of distribution grids. Fast charging or battery swapping charging alternatives would most probably be coupled at the 10 kV level.

Comparing model results on distribution grid loading in not controlled versus controlled EV charging in low voltage grids shows that *controlled charging is increasingly important as the EV share rise in feeders*. Controlled charging *significantly reduces or delays the need for reinvestments in the grid*.

*EVs as power system regulation tools* depend on the level of development of the EV-grid interface. For the DSOs (Distribution System Operators) two cases are important.

Ability to:

- Only start, stop and possibly regulation of charging. (Fairly simple technical solutions).
- Discharging of batteries to deliver energy to the grid (also known as vehicle to grid or V2G). V2G may require alternation of *protection schemes* in some distribution grids.

Start, stop regulation of charging and V2G *may cause local overloading of distribution grids*. Nominal power of the charger and the potential control strategies for charging will determine the total impact EVs will have on the grid.

*Voltage flicker* has been an issue when connecting electrical motors of high load. This is usually solved by adding soft starters to such motors. *EVs may require soft starting algorithms in charging equipment*. Using soft starting of charging may reduce the ability of the EV for delivering fast regulation services. *It does not, however, disqualify the EVs from delivering fast regulation services*.

Attention should furthermore be paid to potential EV impact on *harmonic distortion* from chargers taking into account that charging equipment shall meet Danish/EU requirements.

### **Transmission grid – EV fleet interaction (Chapter 7)**

The EV impact on the power system *highly depends on the EV fleet charging strategy* applied.

If EVs are charged in an *uncontrolled* mode there will be a *considerable need for additional production capacity and transmission grid capacity* to maintain the power adequacy and the security of supply. At the low voltage levels the impact of EVs on grid capacity requirements is an issue. However, at high voltage transmission levels (> 100 kV) the EV fleet impact on needs for grid capacity strengthening is relatively small.

*Controlled EV charging* focusing on day-ahead spot prices could significantly *improve the efficient use of wind power* and improve the use of existing controllable generation capacity. Moreover, adding controlled V2G functionality to EV fleets could further reduce the demand for additional power capacity.

EVs can supply ancillary services. With or without V2G, *EVs can technically deliver primary, secondary and tertiary reserves*.

The individual EV represents a small capacity and resource when compared to the overall power system. Therefore, the development of *strategies and market* solutions to mobilise and take advantage of this *aggregated source of ancillary services* poses a challenge.

At transmission level, the EV impact on the demand for generation capacity and its potential impact on frequency stabilisation are *specific focus areas*.

### **Overall transport and power system aspects:**

**Chapter 8 as well as Chapters 9 and 10** focus on analyses of power systems where electric vehicles are seen as integral part of the model. Chapter 8 presents the modelling of electric vehicles in this context, while chapters 9 and 10 present analyses.

### **EV fleet and overall power system development / investments (Chapter 9)**

Power supply system investments change according to the EV-fleet flexibility. EV flexibility mobilized from the grid infrastructures available and vehicle options influence investment patterns in overall system.

Analyses show that when charged/discharged intelligently electric vehicles (EVs) can facilitate increased wind power investments and can due to V2G (vehicle to grid) capability reduce the need for new coal/natural gas power capacity.

*Detailed analysis of the impact on investments of the EV scenario (introducing EV coverage of well 50% of the (North European) road transport year 2030 shows that wind power likely will provide a large share of the electricity for EVs towards 2030 in several of the Northern European countries.*

However, if not followed up by economic support for renewable energy technologies other than CO<sub>2</sub> quotas, wind power will, for the case of Denmark (and Germany and Sweden) *not contribute in providing electricity for EVs until the last part of the period.* As a result, electricity demand for EVs will in Denmark (and Germany) in the short term likely be met by coal based power.

Large scale implementation of EVs is not sufficient to facilitate reaching the Danish wind target for 2030 by socio-economic optimality. And the effects of EVs on the power system vary significantly from country to country and are sensitive to variations in fuel and CO<sub>2</sub> prices.

In the last part of the period towards 2030, EVs can provide significant CO<sub>2</sub> emission reductions for the Danish energy system as well as for the Northern European countries as a whole.

#### **EV fleet and overall power system interaction and operation (Chapter 10)**

The EV flexibility and its potential ability for controlled smart charging is a potential asset for the overall system. The quantification of such asset for EV in the overall system, however, involves considerable modeling and calculations that of course are associated with large uncertainty.

System operational costs are analysed using the Wilmar model. The analyses include investment costs derived using the Balmorel model.

The analysis has estimated two extremes of EV charging intelligence (not controlled versus controlled/smart charging) and how these might influence the total costs of an optimised future power system.

- In the case of *controlled/smart* EVs, the system cost to charge an electric vehicle calculated as the difference in the *sum of investment costs and operational costs* between the smart scenario and the No EV scenario was around 36 €/vehicle/year.
- In the case of *not controlled/dumb* EVs the system cost was around 263 €/vehicle/year.

Depending on the share of controlled EVs vs. not controlled EVs, the average cost should fall between these extremes – excluding the uncertainties in the results.

Most of the benefits come from the smart timing of charging. This can be divided between benefits accrued to the day-ahead planning phase, and the intraday adjustments to mitigate the forecast errors of electricity demand and variable generation.

Results *exclude grid and intra hour balancing related costs and benefits.* Restrictions in use of the flexibility of smart EVs are not as binding as they are likely to be in the real life.

## Discussion

The above conclusions relate to potential EV impacts in the road transport sector, the power supply sector and the potential synergistic interplay between the transport and power sectors.

A hypothesis for the present study has been that EVs can be seen as an enabling technology with respect to meeting CO<sub>2</sub> reduction aims and integration of fluctuating electricity production, such as wind power. The above conclusions support such expectation.

EV flexibility as to when to charge/discharge improves the system integration of fluctuation production from wind power, and thus contributes synergy for concurrent CO<sub>2</sub> reduction and wind energy utilization in both sectors.

EVs can supply ancillary services. With or without V2G, EVs can technically deliver primary, secondary and tertiary reserves. And proper controlled charging significantly reduces or delays the need for reinvestments in the grid. A considerable part of the EV charging may occur during the night, where both transmission and production capacity are available with the present electricity consumption patterns in Denmark and Europe.

However, challenges exist. One such is to develop (standard) systems being able to mobilise the potential EV regulation capabilities.

Generally for analyses behind the above conclusions is, that a number of externalities have not been quantified nor included. This is partly due to difficulties in quantifying externalities.

Of such EV induced externalities can be mentioned:

- Reduced local pollution incl. noise.
- Oil substitution (reduced reliance on oil) and thus hedging for increasing oil prices (and rising transport costs).
- Improved security of energy supplies (diversified transport energy basis).
- Increased transport and power system robustness and flexibility.

Furthermore, the present analyses have not in detail taken infrastructure cost in the transport and power sectors (e.g. relative to the electricity delivery per customer and eventual needs for strengthening the low voltage distribution grids) into account.

## 12 Appendices

### 12.1 'Snapshot' of Electric Vehicle - related activities.

Table 4 below is an attempt to give a 'snapshot'- impression of the various and vast activity going on within sectors related to alternative and electricity based road transport. The table consists of short headings pointing to EV market expectations, initiatives/activities, development aims, investments etc. Such issues are roughly sorted by sub-sectors and placed on a time scale. This incomplete recording of the accelerating stream of news and events is closed 2010.12.10. That is, the recording has stopped while the global EV-activities soar rapidly!

*Table 4 Expectations to EV market development for Light Passenger Vehicles.*

*An incomplete attempt to present an overview, readable only to whom knowing its content beforehand! Events published beyond 2010.12.10 are not recorded!*

2010.12.10	EV-market Expectations	2010	2015	2020	2030
<b>Battery production</b>		<b>2010</b>	<b>2015</b>	<b>2020</b>	<b>2030</b>
	Hitachi	Tokyo plant: 42000 HEV battery packs/year			
	LG Chem / Compact Power	EV batt. cost down to ½-¼ in 5-10 years			
	NEC Corp.				
	Panasonic / Sanyo Corp.	Global li-ion batt. market to more than triple in 10 y (to \$60Mia.)			
	GS Yuasa Corp.				
	SB LiMotive (Samsung	S.Korea plant Li-ion EV	S.Korea plant Li-ion batt.		

	/Bosch)	batt. prod. start by 2010	for 180.000 EVs by 2015		
	A123/SAIC joint venture	Shanghai Li-ion batt. prod. for EV by 2010			
<b>Auto parts makers</b>		<b>2010</b>	<b>2015</b>	<b>2020</b>	<b>2030</b>
	Suzuki, Yamaha, Harada Seiki, ASTI etc.	Preparing EV parts mass production			
	Shizuoka Economic Research Institute	30% of ICE auto parts not used in EVs			
<b>EV production</b>		<b>2010</b>	<b>2015</b>	<b>2020</b>	<b>2030</b>
	Nissan Renault	Prod. plan: 50000 Leaf EVs in 2011	EVs 5% of global sales in 2016	EVs 10% of global sales in 2020	
	Peugeot				
	Toyota	EV +plug-in hybrids in 2012			
	Mitsubishi	?# i-MiEV in US 2011			
	BYD				
	Daimler				
	BMW	? # MegaCity in 2013		EVs 5-15% of global sales	
	GM	10.000 Chevy Volt in 2011  30.000 Chevy Volt in 2012			
	Ford			HEV+PHEV +BEV:  10-25%	

	Volvo	?# C30 in 2012			
	VW	?# in 2013	EV on road in 2014		
	Audi(in VW)			EVs 5% of own sales	
<b>Research institutions, companies etc.</b>		<b>2010</b>	<b>2015</b>	<b>2020</b>	<b>2030</b>
	Institut für Automobilwirtschaft (IFA)	Global EV production capacity: 0.090 Mio./year	Global EV production capacity: 1.60 Mio./year		
	Pike Research (Consultant)		Forecast 2010: 1.1 Mio EV global sales	2.8 Mio. fuel cell vehicles sold	
	Bloomberg			PHEV+EVs 9% of US market	PHEV+EVs 22% of US market
	Hyder Consulting New Zealand			Forecast Oct. 2009: 2% EVs of fleet	Forecast Oct. 2009: 33% EVs of fleet
	IDC Energy Insights		Forecast Sep. 2010: 2.7 Mio Plug in EVs world wide	Forecast Sep. 2010: 4% Plug in EVs of global fleet	
	J. D. Power		HEV+EVs 3.4% of global light vehicle sales	HEV+EVs 7.4% of global light vehicle sales	
	Frost & Sullivan		EU: 0.48 Mio.EVs		
<b>Infra-structure</b>		<b>2010</b>	<b>2015</b>	<b>2020</b>	<b>2030</b>
	Coulomb Technologies	Fast chargers			
	Pike Research		Projects: 4.7 Mio. EV		



	(Consultant)		charge points worldwide		
	GE	Will buy 25000 EVs before 2015			
<b>National/Government EV targets and policies. Roadmaps.</b>		<b>2010</b>	<b>2015</b>	<b>2020</b>	<b>2030</b>
	USA Recovery Act		Aim: 1. Mio. plug-in HEVs		
	France			Aim: 4. Mio. EVs	
	Spain		Aim: 1. Mio. EVs by 2014		
	Germany			Aims to have / produce: 1. Mio. EVs	Aims to have / produce: 5. Mio. EVs
	UK				
	Norway			Aim: 0.2 Mio. EVs	
	Japan			Aim: EVs 50% of sales	
	China		Aims for: 2.66 Mio. EVs ?	Aims for: 5.0 Mio. EVs Production capacity: 1Mio.EV/y	
<b>Power producers</b>		<b>2010</b>	<b>2015</b>	<b>2020</b>	<b>2030</b>
	EPRI 2007	Forecast: 0% PHEVs of US sales	Forecast: 11% PHEVs of US sales	Forecast: 37% PHEVs of US sales	Forecast: 53% PHEVs of US sales
	Manitoba Electric Power (Canada)		As EPRI2007 forecast with 2 years delay		
<b>Research organizations</b>		<b>2010</b>	<b>2015</b>	<b>2020</b>	<b>2030</b>
	IEA and 'Electric Vehicle Initiative'			Global forecast/aim: 20 Mio. EVs+PHEVs on roads	Global forecast/aim: 200 Mio. EVs+PHEVs on roads

**Estimation of US-supply of EV's:**

Estimated U.S. Supply of Electric Vehicles from 2011 through 2015						
<b>Manufacturer and Model</b>	<b>2011</b>	<b>2012</b>	<b>2013</b>	<b>2014</b>	<b>2015</b>	<b>Total</b>
Fisker Karma PHEV	1,000	5,000	10,000	10,000	10,000	36,000
Fisker Nina PHEV		5,000	40,000	75,000	75,000	195,000
Ford Focus EV		10,000	20,000	20,000	20,000	70,000
Ford Transit Connect EV	400	800	1,000	1,000	1,000	4,200
GM Chevrolet Volt	15,000	120,000	120,000	120,000	120,000	505,000
Navistar eStar EV (truck)	200	800	1,000	1,000	1,000	4,000
Nissan LEAF EV	25,000	25,000	50,000	100,000	100,000	300,000
Smith Electric Vehicles Newton EV (truck)	1,000	1,000	1,000	1,000	1,000	5,000
Tesla Motors Model S EV		5,000	10,000	20,000	20,000	55,000
Tesla Motors Roadster EV	1,000					1,000
Think City EV	2,000	5,000	10,000	20,000	20,000	57,000
<b>Cumulative Total</b>						<b>1,222,200</b>

Note: The above numbers have been taken from announced production figures and media reports. In some cases more conservative estimates have been used due to: delays that have occurred since announced

Reference: [www.energy.gov/news/documents/1\\_Million\\_Electric\\_Vehicle\\_Report\\_Final.pdf](http://www.energy.gov/news/documents/1_Million_Electric_Vehicle_Report_Final.pdf) (2011.2.10)

## 12.2 Models

### Sivael

Sivael is a simulation program designed for simulation of a thermal power system with combined heat and power, wind power, heat pumps, heat storage, pump storage and exchange with neighbouring systems. Sivael produces an optimal load dispatch for one week at a time with one hour resolution with start/stop of thermal units.

Sivael has a stochastic model for forced outage on thermal units, and a stochastic model for predicting errors on wind production.

It is possible to add penalty to different emissions and have up to three different fuel types with a maximum share on thermal units. Sivael automatic chooses the cheapest combination of fuels for each unit taking penalties into account.

Sivael is event driven and contains a true calendar. I.e. all data may change from one hour to the next.

Sivael is not a multi area model, but only a two area model (DK1 and DK2) with defined boundary conditions for electricity prices in neighbour price areas. Sivael produces a standard report but all results can be extracted to Excel on hourly basis.

### Assess

Assess is a probabilistic simulation tool designed by the French TSO, RTE. The power grid, power generation system and power load are defined technically and economically in the model. Stochastic parameters for the availability of grid elements and production units are defined in the model, and a large number of stochastic samplings (32,000) can be simulated in an Optimal Power Flow calculation. Load-flow simulation can be carried out for each sampling in AC or DC simulation mode. On the basis of the statistical output analysis, eg in SAS, the amount of unserved energy (energy not delivered to meet demand) can be calculated. Furthermore, the statistical costs due to grid restrictions can be calculated.

### Balmorel

The Balmorel model handles electricity and CHP systems in an international perspective. It is mainly a bottom-up model (classical technical/economical modeling) but it allows for inclusion of top-down elements (based on e.g. econometric analyses).

The model in its base version is flexible, permitting focus on large geographical area and a far-reaching time perspective with correspondingly less degree of details; or it may emphasize shorter time steps and horizons on a more limited geographical scope. To some extent the perspectives may be combined.

The model operates under assumptions of a perfectly competitive energy system. The solution of the model will maximize the social welfare, understood as consumers' utility minus producers' costs.

The model is implemented in a modern modeling language which allows for a relatively easy modification of the functionalities and which ensures a fully documented functionality (in the form of relatively transparent program code). The source code is open source, permitting users to make modifications according to specific needs; this property was applied in the present project, cf. Chapter 8. See [www.Balmorel.com](http://www.Balmorel.com) for further information.

In the context of this project the Balmorel model has been used for making endogenous investments in the North European system on both EVs and on the production units of the power and cph system, thus permitting analysis of long term aspects of the interplay between these two components. It has also been used for hourly simulations for analysis of more detailed operation patterns of the systems. See Chapters **Error! Reference source not found.** and 10.

## **Wilmar**

The Wilmar model was described and applied in Chapter 10, and the modeling of EV for Wilmar are described in 8.2, Please refer to those parts for details.

## 12.3 Input data for the analysis in Chapter 9

In this Appendix, modelling preconditions and data inputs used in for the analysis in Chapter 9 are presented.

### Power regions, district heating areas and time resolution

In order to obtain reasonable computation times, Norway, Sweden and Finland are each treated as one power region. Denmark is divided into two regions: Western Denmark being synchronous with the UCTE power system and Eastern Denmark being synchronous with the Nordel power system. Germany is aggregated into two regions, representing the transmission bottlenecks between the large consumption centres in Central & South Germany and Northern Germany with its large share of wind power.

Intending to limit computation times, Sweden, Norway and Finland are each represented as one common district heating area. For Denmark, district heating is divided into four areas; East Urban, East Rural, West Urban and West Rural. Germany is modelled as two district heating areas corresponding to the power regions, i.e. Central & Southern Germany and Northern Germany, respectively. The distribution of national electricity demands on regions and of district heating demand on areas is assumed unchanged over the period 2010 to 2030.

Intending to capture wind power fluctuations and to obtain a satisfactory optimisation of power flows between grid and vehicles, an hourly time resolution is chosen. To limit calculation times, 7 weeks are simulated and weighted to represent a full year. The calculation time for a model run with EVs covering 2015, 2020, 2025, and 2030 with this time resolution is approximately 24 hours on a 3.4 GHz quad core computer with 8 GB RAM.

### Electricity, district heating and transport demands

Data inputs used for annual demands for electricity, district heating and transport are given in the following tables.

Table 5. Electricity demands

TWh/yr	2010	2015	2020	2025	2030
Denmark	33.5	32.5	33.8	34.1	35.6
Norway	116.2	119.2	124.1	126.8	128.4
Sweden	137.7	141.3	147.0	150.2	152.1
Finland	85.9	89.2	94.5	98.6	101.4
Germany	539.3	553.9	584.6	600.4	613.9

Sweden, Finland, Germany: [1] Norway (non-EU country): scaled based on current relation between Norwegian and Swedish demand, Denmark: [2]

Table 6. District heating demands

TWh/yr	2010	2015	2020	2025	2030
Denmark	28.0	28.0	28.0	27.9	27.9
Norway	2.7	2.8	2.8	2.8	2.8
Sweden	45.0	46.3	46.7	46.7	46.3
Finland	45.4	49.9	54.7	55.9	55.7
Germany	92.6	95.7	100.4	101.0	101.9

Sweden, Finland, Germany: [1], Norway (non-EU country): scaled based on current relation between Norwegian and Swedish demand, Denmark: [2]

Table 7. Transport demands

10 <sup>9</sup> person km/yr	2010	2015	2020	2025	2030
Denmark	57.3	60.1	63.0	65.9	68.8
Norway	52.8	54.9	56.9	58.9	61.0
Sweden	112.3	116.9	121.1	125.3	129.7
Finland	71.6	72.8	73.1	73.1	73.2
Germany	1024.6	1068.7	1092.3	1102.6	1115.9

Sweden, Finland, Germany: based on [1], Norway (non-EU country): scaled based on current relation between the amount of cars in Norway and Sweden, respectively, Denmark based on [1], [3]

An iterative process has been required in order to make the total transport demands fit with the number of each type of vehicles, the annual driving distances for ICEs/PHEVs and BEVs and the driving patterns. In this regard, the total transport demands have been adjusted and are still close to the demands in the sources used.

## Vehicle data

It is assumed that BEVs of vintage 2015 and 2020 can cover trips lasting up to 2 hours (corresponding to 115 km) yielding an annual driving of 10,230 km/y and that BEVs of vintage 2025 and 2030 can cover trips of up to 3 hours (corresponding to 205 km) yielding 12,671 km/y. This is considered reasonable based on the distances supported by the BEV battery capacities in Table 9; assuming that people will be reluctant to drive close to emptying the battery and that spare battery capacity will in some cases be required for a second trip in the day. If assuming that BEVs could cover 4 trips of up to hours it would yield 14,435 km/y, i.e. only moderately higher annual driving. Hence, these assumptions are not expected to have great influence on the result.

Table 8. Annual driving for each vehicle type

km/yr	2015	2020	2025	2030
ICE/PHEV	18,072	18,401	18,676	19,126
BEV	10,230	10,230	12,671	12,671

Costs, vehicle efficiencies, electric storage capacities and battery ranges assumed for the different vehicle technologies are given in *Table 9*. As in the study in general, all costs are socio-economic and given in €2008.

*Table 9. Vehicle technology data.*

Veh. type	Vintage	Inv. cost (€/yr) <sup>a</sup> [4, 5]	O&M cost (€/yr) [5]	Elec.stor. cap. <sup>b</sup> (kWh) [4]	Eff. (km/kWh) [6] <sup>c</sup>	Bat. range (km) <sup>d</sup> [6] <sup>c</sup> , [7]
ICE	2015	1,058	1,168	-	1.8	-
	2020	1,058	1,168	-	1.9	-
	2025	1,058	1,168	-	1.9	-
	2030	1,058	1,168	-	2.0	-
BEV	2015	3,035	1,101	40	5.5	220
	2020	2,509	1,101	43	6.0	260
	2025	1,962	1,101	47	6.5	303
	2030	1,745	1,101	50	7.0	350
PHEV	2015	2,122	1,168	12	5.5	65
	2020	1,784	1,168	11	6.0	65
	2025	1,521	1,168	10	6.5	65
	2030	1,387	1,168	9	7.0	65

<sup>a</sup> A discount rate of 5 % is applied in fixed prices. A vehicle life time of 16 years is assumed.

<sup>b</sup> The usable storage capacity of the battery.

<sup>c</sup> 5 km/kWh for EV vintage of 2010 and 7 km/kWh for vintage of 2030 [6].

<sup>d</sup> Battery range of 150 km for BEV vintage 2010 and 350 km for BEV vintage 2030 [6]. To yield values for all vehicle vintages, data from references are supplemented with linear interpolation.

## Existing power systems

The model includes data for power/heat production, storage and transmission capacities, as well as technical and economic data for the existing units. The current electricity production distributed on sources for each of the five countries is illustrated in Figure 73, as generated by the model.

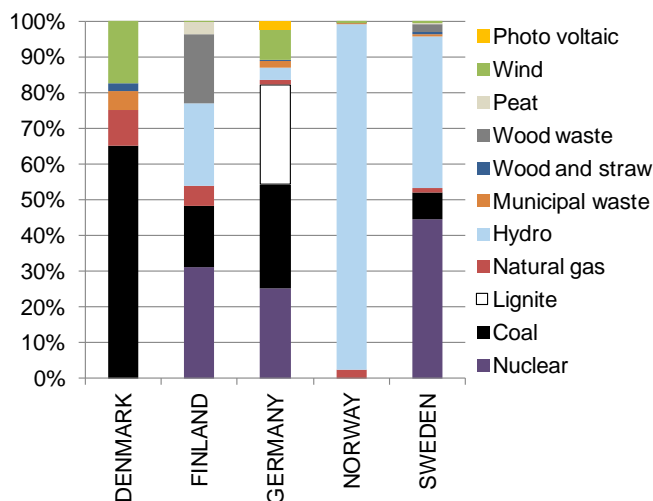

*Figure 73 Electricity generation in the present power systems of five Northern European countries distributed on sources. The distribution is generated by the model for 2010 for the Base scenario when not allowing investments in new capacities.*

## Technologies available for investment

The power system units available for investment in the analysis are given in *Table 10*.

*Table 10. Technologies available for investment in the optimisation.*

Technology	Fuel	Period available	Inv. cost <sup>a</sup> (M€MW)	Variable O&M cost (€MWh)	Fixed O&M cost (k€MW/yr)	Lifetime (years)	Eff. <sup>b</sup>	CB	CV	Ref.
Onshore wind turbine	-	2011-2020	1.33	12.50	-	20	1.00	-	-	[8]
	-	2021-2030	1.24	11.75	-	25	1.00	-	-	[8]
Offshore wind turbine	-	2011-2020	2.50	17.00	-	20	1.00	-	-	[8]
	-	2021-2030	2.25	15.50	-	25	1.00	-	-	[8]
Steam turbine, extraction	Coal	2011-2020	1.43	7.00	-	40	0.46	0.75	0.15	[8]
		2021-2030	1.40	7.00	-	40	0.50	0.93	0.15	[8]
Open cycle gas turbine, condensing	Natural gas	2011-2030	0.32	2.40	16	20	0.37	-	-	[9]
Combined cycle gas turbine, extraction	Natural gas	2011-2020	0.52	3.20	20	25	0.59	1.55	0.13	[8, 9]
		2021-2030	0.47	3.20	20	25	0.62	1.75	0.13	[8, 9]
Nuclear, condensing <sup>c</sup> Steam turbine, extraction	Uranium	2011-2030	2.81	7.7	56	40	0.37	-	-	[9]
	Wood	2011-2020	1.68	3.20	23	30	0.46	0.53	0.15	[8]
Steam turbine, back pressure	Wood	2021-2030	1.60	3.20	23	30	0.48	0.58	0.15	[8]
		2011-2020	4.40	-	154	20	0.25	0.30	-	[8]
Steam turbine, back pressure	Straw	2021-2030	3.95	-	138	20	0.25	0.30	-	[8]
		2011-2020	4.35	-	174	20	0.30	0.49	-	[8]
Heat boiler	Wood	2011-2030	0.50	-	24	20	1.08	-	-	[8]
	Natural gas	2011-2030	0.09	-	3.2	20	1.01	-	-	[8]
Heat pump <sup>d</sup>	Electricity	2011-2020	0.65	-	6.9	20	2.8	-	-	[8, 10]
		2021-2030	0.65	-	6.9	20	3.0	-	-	[8, 10]
Electric boiler	Electricity	2011-2030	0.06	0.5	1	20	0.99	-	-	[8]
Heat storage	-	2011-2030	0.00185	-	-	20	0.99	-	-	[11]

<sup>a</sup> Based on [12], investment costs are in the model annualised with a discount rate of 5 % given in fixed prices. Investment costs for heat storage are given in M€MWh storage.

<sup>b</sup> For heat boilers, heat efficiency, for heat pumps, coefficient of performance, and for other units, electric efficiency.

<sup>c</sup> Allowed in Finland and Sweden only.

<sup>d</sup> Investment costs for heat pumps given in M€MW-thermal.



## Fuel prices and CO<sub>2</sub> prices

Fuel and CO<sub>2</sub> prices applied in the main scenarios are given below.

Table 11. Fuel and CO<sub>2</sub> quota price projections for 2010-2030 (€/GJ) [13]

	Fuel oil	Diesel	Natural gas	Coal	Lignite	Uranium [18]	Wood [14]	Wood waste [14]	Straw	CO <sub>2</sub> (€/ton)
2010	6.7	14.8	6.0	2.9	1.5	0.7	6.0	0.0	5.1	14
2015	8.3	17.7	8.2	2.9	1.4	0.7	6.6	0.0	5.8	20
2020	9.4	19.7	9.2	3.2	1.6	0.7	6.9	0.0	5.9	25
2025	10.2	21.0	10.0	3.4	1.7	0.7	7.2	0.0	6.1	32
2030	10.9	22.4	10.7	3.4	1.7	0.7	7.5	0.0	6.2	39

Fuel costs include distribution costs. Municipal waste is assumed to have zero cost applying a socio-economic perspective.

## Wind potentials and targets

For Denmark, the onshore wind power is set to 4500 MW [15]. Based on planned wind power capacities in Energinet.dk (2010) [16], the onshore potential is assumed distributed on 3500 MW in Western Denmark and 1000 MW in Eastern Denmark. For the other countries, onshore wind potentials are uncertain and difficult to estimate. Therefore, onshore wind power capacities are for these countries assumed limited to national high wind targets for 2030.

Table 12. Wind targets for 2030 and assumed onshore wind potentials

MW	Medium wind target [17]	High wind target [17]	Onshore wind potential
Denmark	7,291	8,020	4,500 [15]
Norway	5,980	11,970	12,000 <sup>a</sup>
Sweden	10,000	17,000	17,000 <sup>a</sup>
Finland	3,200	6,000	12,000 <sup>b</sup>
Germany	54,244	63,587	63,600 <sup>a</sup>

<sup>a</sup> Due to the large areas of these countries and uncertainties in estimating the onshore wind potential, the maximum onshore wind power capacity is assumed limited to the high wind target. <sup>b</sup> The Finnish high wind target is considered unrealistically low and therefore, onshore wind power in Finland is assumed limited to 12,000 MW corresponding to the Norwegian high wind target.

Offshore wind potentials are very high compared to the offshore wind power investments generated by the model. Therefore, offshore wind potentials have no relevance for the results.

## Hydro power generation

Hydro power is characterized by implementation barriers and costs that are site specific to a higher degree than many other sources of electricity generation [99.1]. Based on this, investments in new hydro power capacities are not identified as part of the optimisation. Instead, the expected development in hydro power generation is included as fixed (annual) production levels (see Table 13).

*Table 13. Hydro power generation assumed.*

TWh/yr	2010	2015	2020	2025	2030	Ref.
Germany	19.7	20.8	20.9	21.4	22.0	[1]
Finland	13.8	13.9	14.0	14.2	14.4	[1]
Norway	126.8	131.8	136.8	141.8	146.8	[99.1] [1],
Sweden	66.4	66.7	67.0	67.0	67.0	[19] <sup>a</sup>

<sup>a</sup> Swedish hydro power production in 2010 set to the average production for the last five years based on [19] and relative increase based on [1].

## References

- [1] European Commission, Directorate-General for Energy and Transport. European energy and transport - trends to 2030 — update 2007. 2008 Available: [http://ec.europa.eu/dgs/energy\\_transport/figures/trends\\_2030\\_update\\_2007/energy\\_transport\\_trends\\_2030\\_update\\_2007\\_en.pdf](http://ec.europa.eu/dgs/energy_transport/figures/trends_2030_update_2007/energy_transport_trends_2030_update_2007_en.pdf).
- [2] Danish Energy Authority. Danmark energifremskrivning, april 2010. 2010 Available: [http://www.ens.dk/Documents/Netboghandel%20-%20publikationer/2010/danmarks\\_energifremskrivning.pdf](http://www.ens.dk/Documents/Netboghandel%20-%20publikationer/2010/danmarks_energifremskrivning.pdf).
- [3] M. Fosgerau, C. Brems, C. Jensen, N. Pilegaard, M. Holmblad, O. Kveiborg and L. P. Nielsen. Langsigtet fremskrivning af vejtrafik - indikation af fremtidige problemområder - baggrundsrapport. Danish Transport Research Institute (DTU Transport). 2007 Available: <http://www.transport.dtu.dk/Nyheder/Nyhedsarkiv/Arkiv,%20DTF.aspx?guid={559A9B5A-6527-4728-AB83-FA7A4024B5E3}>.
- [4] IEA. Technology roadmap - electric and plug-in hybrid electric vehicles. 2009 Available: [http://www.iea.org/papers/2009/EV\\_PHEV\\_Roadmap.pdf](http://www.iea.org/papers/2009/EV_PHEV_Roadmap.pdf).
- [5] COWI. Teknologivurdering af alternative drivmidler transportsektoren. Danish Energy Authority. 2007.
- [6] N. Juul and P. Meibom, "Optimal configuration of an integrated power and transport system," *Energy*, vol. 36, pp. 3523-3530, 5, 2011.
- [7] Risø DTU National Laboratory for Sustainable Energy, "Risø energy report 8: The intelligent energy system infrastructure for the future," Risø DTU, Denmark, 2009.
- [8] Danish Energy Authority, "Technology data for energy plants," Danish Energy Authority, 2010.
- [9] IEA, Tackling investment challenges in power generation, 2007.
- [10] P. E. Morthorst, Risø DTU National Laboratory for Sustainable Energy, Tech. Rep. Risø-R-1234(DA), Varmepumper og lavtemperaturfjernvarme. Rapportering fra to workshops. Delrapportering fra EFP-projekt Effektiv fjernvarme i fremtidens energisystem. 2008.
- [11] K. Ellehauge and T. E. Pedersen, "Solar heat storages in district heating networks," *Energinet.dk*, 2007.
- [12] Danish Commission on Climate Change Policy. Dokumentationsdelen til klimakommissionens samlede rapport. grøn energi - vejen mod et dansk energisystem uden fossile brændsler. 2010 Available: <http://www.klimakommissionen.dk/da-DK/OmKlimakommissionen/Klimakommissionensrapport/Sider/Forside.aspx>.
- [13] Danish Energy Authority. Forudsætninger for samfundsøkonomiske analyser på energiområdet. Danish Energy Authority. 2010.
- [14] J. Kiviluoma and P. Meibom, "Influence of wind power, plug-in electric vehicles, and heat storages on power system investments," *Energy*, vol. 35, pp. 1244-1255, 3, 2010.
- [15] B. V. Mathiesen, H. Lund and K. Karlsson, "IDAs klimaplan 2050: Tekniske energisystemanalyser og samfundsøkonomisk konsekvensvurdering," Danish Society of Engineers, Copenhagen, Denmark, 2009.

- [16] Energinet.dk, "Analyseforudsætninger 2010-2020, 2025 og 2030 (energinet.dk: The danish TSO)," Energinet.dk; 2010.
- [17] B. Lemström, S. Uski-Joutsenvuo, H. Holttinen, N. A. Cutululis, P. Sørensen, L. Warland and M. Korpås. Effects of increasing wind power penetration of the power flows in the european grids. 2008 Available: [http://www.trade-wind.eu/fileadmin/documents/publications/D5-1\\_Effects\\_of\\_increasing\\_wind\\_power.pdf](http://www.trade-wind.eu/fileadmin/documents/publications/D5-1_Effects_of_increasing_wind_power.pdf).
- [18] Münster M, Meibom P. Optimization of use of waste in the future energy system. Energy 2011; 36(3):1612-22.
- [19] Swedish Energy Agency. Energy in Sweden: facts and figures 2010. Bromma, Sweden: Swedish Energy Agency. Available: <http://webbshop.cm.se/System/TemplateView.aspx?p=Energimyndigheten&view=default&cat=/Broschyrer&id=e0a2619a83294099a16519a0b5edd26f> ; 2010.
- [20] Redegørelse om rammebetingelser for opstilling af ladestationer til elbiler, Energistyrelsen, 2011.
- [21] Transportøkonomiske Enhedspriser til brug for samfundsøkonomiske analyser, DTU Transport 2010
- [22] Nielsen, L.H.; Jørgensen K. Electric vehicles and renewable energy in the transport sector - energy system consequences. Main focus: Battery electric vehicles and hydrogen based fuel cell vehicles. Risø-R-1187(EN) (ISBN: 87-550-2710-5), pages: 79, 2000.
- [23] Nielsen, L.H.; Morthorst, P.E. (eds.); Jørgensen, P.; Eriksen, P.B.; Gruelund Sørensen, A.; Nissen, F.; Godske, B.; Ravn, H.F.; Søndergren, C.; Stærkind, K.; Havsager, J.; Skytte, K.; Hjuler Jensen, P., Fluktuerende vedvarende energi i el- og varmforsyningen - det mellemlange sigt. Risø-R-1055(DA) (1998) 152 p.
- [24] Nielsen, Lars Henrik; Jørgensen, Kaj. Alternative Fuels and Sustainable Development: - Electric, Hybrid and Hydrogen Propulsion in Denmark. DTU-IBE-SR-9822, pages: 100, 1998.
- [31] COWI. Teknologivurdering af alternative drivmidler transportsektoren. Danish Energy Authority. 2007.
- [32] Danish Energy Authority (DEA). Baseline forecast from April 2010.
- [34] Danish Energy Authority (DEA). Baseline forecast from April 2011.
- [35] US DOE: Recovery Act: Transforming America's Transportation Sector. Batteries and Electric Vehicles. 14 July 2010.
- [41] Langsigtet fremskrivning af vejtrafik. Supplerende analyser. Mogens Fosgerau, Camilla Brems, Carsten Jensen. Danmarks Transport Forskning. Rapport 2007.
- [42] EPRI report nr. 1015326. (2007). [http://energy.gov/sites/prod/files/oeprod/DocumentsandMedia/EPRI-NRDC\\_PHEV\\_GHG\\_report.pdf](http://energy.gov/sites/prod/files/oeprod/DocumentsandMedia/EPRI-NRDC_PHEV_GHG_report.pdf)
- [43] IEA: Blue Map scenario. 2009.

- [44] Langsigtet fremskrivning af vejtrafik, hovedrapport og baggrundsrapport, Mogens Fosgerau, Camilla Brems, Carsten Jensen, Ninette Pilegaard, Mikal Holmblad, Ole Kveiborg, Lisbeth Palmhøj Nielsen. DTF rapport 2, februar 2007.
- [45] DTU Transport: 'Transport Vane Undersøgelse: 2006+2007'. April 2009.  
<http://www.regionh.dk/NR/rdonlyres/AECCBC70-3A59-4964-962F-EAC02224F1FA/0/Transportvanerihovedstadsregionen.pdf>
- [46] The EMMA model, Risø DTU, 2007.
- [5.1] Rune Mønnike: *Bilparkens tilgængelighed i en V2G Infrastruktur*, Pre-Master Project, DTU Electrical Engineering, Sept. 2008 (in Danish)
- [5.2] J. Grassin; *Vehicle to Grid – Improving Wind Power Integration?*, Master Thesis, Ørsted.DTU 2007
- [5.3] Rune Mønnike, *Den intelligente ladestander og afledte kommunikation/datastrukturer, Et V2G Case study* M.Sc. Project, DTU Electrical Engineering, Aug 2009 (in Danish)
- [5.4] Ingólfur Örn Ómarsson, *Analysis of Communication System for Electrical Vehicles connected to the Grid* Master 's Thesis, Ørsted.DTU November 2008
- [5.5] Ali Adel Mahmoud, *Integration of Wind Power and Electrical Vehicle to Provide Regulating Power in a System with High Wind Power Penetration*, Master Thesis, DTU.Elektro August 2010
- [5.6] Divya K. Chandrashekhara et . al.: *Vehicle to Grid (V2G) in Denmark – Feasibility Study*, DTU Electrical Engineering, June 2008 (Confidential)
- [5.7] [www.edison-net.dk](http://www.edison-net.dk)
- [61] “Elbiler i lavspændingsnettet”, Allan Norsk Jensen, Collaborative project with Energinet.dk, NRGi and Dansk Energi.62]“Smart Grid”, Energinet.dk and Dansk Energi, Available online (in Danish): [http://www.danskeenergi.dk/Aktuelt/Indblik/Smart\\_Grid.aspx](http://www.danskeenergi.dk/Aktuelt/Indblik/Smart_Grid.aspx)
- [63] “Electric Vehicles in Power Systems with 50% Wind Power Penetration: the Danish Case and the EDISON programme”, Østergaard et.al. 2009, Paper – European Conference SmartGrids and Mobility
- [71] Efficient integration of windpower in Denmark, Energinet.dk 2009
- [72] Strategy for the investment in 132/150 infrastructure, Energinet.dk 2009
- [73] Smart Grid in Denmark, Dansk Energi & Energinet.dk 2010
- [74] Energy 2050 - development of the energy system, Energinet.dk 2010
- [81] Kiviluoma, J., Meibom, P., Methodology for modelling plug-in electric vehicles in the power system and cost estimates for a system with either smart or dumb electric vehicles, Energy, Vol. 36, Issue 3, pp. 1758-1767, 2011, epublished, DOI: 0.1016/j.energy.2010.12.053.

- [82] Meibom, P., Barth, R., Hasche, B., Brand, H., O'Malley, M., Stochastic optimisation model to study the operational impacts of high wind penetrations in Ireland, IEEE Transactions of Power Systems, epublished, DOI: 10.1109/TPWRS.2010.2070848.
- [83] Meibom, P., Barth, R., Brand, H., Hasche, B., Swider, D., Ravn, H., Weber, C., All Island grid study – Wind variability management studies, in series: Workstream 2B, pages: 138, 2008, Department of Enterprise, Trade and Investment, Dublin.
- [84] Ravn H, et al., Balmorel: A Model for Analyses of the Electricity and CHP Markets in the Baltic Sea Region, 2001, [www.Balmorel.com](http://www.Balmorel.com)
- [85] Juul, N., Meibom, P., Optimal configuration of future energy systems including road transport and vehicle-to-grid capabilities, European Wind Energy Conference (EWEC), Scientific Proceedings 2009, p. 168-174, 2009
- [86] Juul, N., Meibom, P., Optimal configuration of an integrated power and transport system, Accepted Energy, 2011
- [91] Electric Power Research Institute (EPRI), "Environmental assessment of plug-in hybrid electric vehicles, volume 1: Nationwide greenhouse gas emissions," 2007.
- [92] IEA. Technology roadmap - electric and plug-in hybrid electric vehicles. 2009 Available: [http://www.iea.org/papers/2009/EV\\_PHEV\\_Roadmap.pdf](http://www.iea.org/papers/2009/EV_PHEV_Roadmap.pdf).
- [93] N. Juul and P. Meibom, "Optimal configuration of an integrated power and transport system," *Energy*, vol. 36, pp. 3523-3530, 5, 2011.
- [94] Danish Transport Research Institute (DTU Transport), "Transportvaneundersøgelsen," 2006.
- [95] Danish Energy Authority. Forudsætninger for samfundsøkonomiske analyser på energiområdet. Danish Energy Authority. 2010.
- [96] J. Kiviluoma and P. Meibom, "Influence of wind power, plug-in electric vehicles, and heat storages on power system investments," *Energy*, vol. 35, pp. 1244-1255, 3, 2010.
- [97] N. Juul, "PhD thesis. modelling and analysis of distributed energy systems with respect to sustainable energy - focus on electric drive vehicles." Risø DTU National Laboratory for Sustainable Energy, Lyngby, Denmark, 2011.
- [98] B. Lemström, S. Uski-Joutsenvuo, H. Holttinen, N. A. Cutululis, P. Sørensen, L. Warland and M. Korpås. Effects of increasing wind power penetration of the power flows in the european grids. 2008 Available: [http://www.trade-wind.eu/fileadmin/documents/publications/D5-1\\_Effects\\_of\\_increasing\\_wind\\_power.pdf](http://www.trade-wind.eu/fileadmin/documents/publications/D5-1_Effects_of_increasing_wind_power.pdf).
- [99] Energinet.dk, "Analyseforudsætninger 2010-2020, 2025 og 2030 (energinet.dk: The danish TSO)," Energinet.dk;, 2010.
- [99.1] Ea Energy Analyses. Sustainable energy scenarios: energy perspectives for the Baltic Sea region. Copenhagen, Denmark: Ea Energy Analyses. Available at: [http://www.bssc.com/upload/dokumenty/f\\_17.pdf](http://www.bssc.com/upload/dokumenty/f_17.pdf); 2009.

[99.2] Vogstad K. Utilising the complementary characteristics of wind power and hydropower through coordinated hydro production scheduling using the EMPS model. Trondheim, Norway: Department of Electrical Engineering; 2000.

[99.3] The Swedish Government. The Swedish national action plan for the promotion of the use of renewable energy in accordance with Directive 2009/28/EC and the commission decision of 30.06.2009. The Swedish Government. Available at: [http://ec.europa.eu/energy/renewables/transparency\\_platform/action\\_plan\\_en.htm](http://ec.europa.eu/energy/renewables/transparency_platform/action_plan_en.htm) ; 2010.

[99.4] Fraunhofer Institute for Wind Energy and Energy System Technology. Full load hours onshore-offshore. Available at: [http://windmonitor.iwes.fraunhofer.de/windwebdad/www\\_reisi\\_page\\_new.show\\_page?page\\_nr=470&lang=en&owa=&owa\\_own\\_header=0](http://windmonitor.iwes.fraunhofer.de/windwebdad/www_reisi_page_new.show_page?page_nr=470&lang=en&owa=&owa_own_header=0); Accessed on October 12, 2011.

[99.5] Federal Republic of Germany. National renewable energy action plan in accordance with Directive 2009/28/EC on the promotion of the use of energy from renewable sources. Available at: [http://ec.europa.eu/energy/renewables/transparency\\_platform/action\\_plan\\_en.htm](http://ec.europa.eu/energy/renewables/transparency_platform/action_plan_en.htm); 2010.

[101] *Dansk Energi, Energinet.dk*, Smart grid i Danmark, 2010, available from [www.danskenergi.dk/Aktuelt/Indblik/Smart\\_Grid.aspx](http://www.danskenergi.dk/Aktuelt/Indblik/Smart_Grid.aspx)

[102] Kiviluoma, J., Meibom, P., Influence of wind power, plug-in electric vehicles, and heat storages on power system investments, *Energy*, Vol. 35, pp. 1244-1255, 2010.

[103] Danish Energy Agency, Energinet.dk, Technology data for Energy plants, June 2010, [http://www.ens.dk/Documents/Netboghandel%20-%20publikationer/2010/Technology\\_data\\_for\\_energy\\_plants.pdf](http://www.ens.dk/Documents/Netboghandel%20-%20publikationer/2010/Technology_data_for_energy_plants.pdf)

[104] *Hovedrapport for Smart Grid Netværkets arbejde; Klima-, energi- og bygningsministeriet. Oktober 2011.*





Risø DTU is the National Laboratory for Sustainable Energy. Our research focuses on development of energy technologies and systems with minimal effect on climate, and contributes to innovation, education and policy. Risø has large experimental facilities and interdisciplinary research environments, and includes the national centre for nuclear technologies.

---

**Risø DTU**  
**National Laboratory for Sustainable Energy**  
**Technical University of Denmark**

Frederiksborgvej 399  
PO Box 49  
DK-4000 Roskilde  
Denmark  
Phone +45 4677 4677  
Fax +45 4677 5688

[www.risoe.dtu.dk](http://www.risoe.dtu.dk)