

Technical University of Denmark



## Nuclear Safety Research and Facilities Department annual report 1997

**Majborn, Benny; Aarkrog, Asker; Brodersen, Knud Erik; Damkjær, Anders; Floto, Heinz; Heydorn, Kaj; Nielsen, Sven Poul; Nonbøl, Erik; Ølgaard, Povl Lebeck**

*Publication date:*  
1998

*Document Version*  
Publisher's PDF, also known as Version of record

[Link back to DTU Orbit](#)

*Citation (APA):*  
Majborn, B., Aarkrog, A., Brodersen, K., Damkjær, A., Floto, H., Heydorn, K., ... Ølgaard, P. L. (1998). Nuclear Safety Research and Facilities Department annual report 1997. (Denmark. Forskningscenter Risoe. Risoe-R; No. 1019(EN)).

## DTU Library

Technical Information Center of Denmark

---

### General rights

Copyright and moral rights for the publications made accessible in the public portal are retained by the authors and/or other copyright owners and it is a condition of accessing publications that users recognise and abide by the legal requirements associated with these rights.

- Users may download and print one copy of any publication from the public portal for the purpose of private study or research.
- You may not further distribute the material or use it for any profit-making activity or commercial gain
- You may freely distribute the URL identifying the publication in the public portal

If you believe that this document breaches copyright please contact us providing details, and we will remove access to the work immediately and investigate your claim.

# **Nuclear Safety Research and Facilities Department Annual Report 1997**

**Edited by B. Majborn, A. Aarkrog, K. Brodersen,  
A. Damkjær, H. Floto, K. Heydorn, S.P. Nielsen,  
E. Nonbøl and P.L. Ølgaard**



**Risø National Laboratory, Roskilde, Denmark  
April 1998**

**Abstract** The report presents a summary of the work of the Nuclear Safety Research and Facilities Department in 1997. The department's research and development activities were organized in four research programmes: Reactor Safety, Radiation Protection, Radioecology, and Radioanalytical Chemistry. The nuclear facilities operated by the department include the research reactor DR3, the Isotope Laboratory, the Waste Treatment Plant, and the educational reactor DR1. Lists of staff and publications are included together with a summary of the staff's participation in national and international committees.

**Cover illustration:**

Bylot Sound close to the site near Thule air base in north-west Greenland where a B52 bomber carrying nuclear weapons crashed on the sea ice in January 1968. In August-September 1997 a new sampling expedition took place in the area (cf. section 4.2)

(Photo: H. Dahlgaard)

ISBN 87-550-2344-4

ISSN 0106-2840

ISSN 1396-3619

Information Service Department, Risø, 1998

# Contents

<b>1</b>	<b><i>Introduction</i></b>	<b>5</b>
<b>2</b>	<b><i>Reactor safety</i></b>	<b>5</b>
2.1	<i>Reactor physics</i>	5
2.2	<i>Severe accidents</i>	7
2.3	<i>Decommissioning of research reactors</i>	9
2.4	<i>Nuclear information</i>	10
<b>3</b>	<b><i>Radiation protection</i></b>	<b>10</b>
3.1	<i>Dosimetry</i>	11
3.2	<i>Optically stimulated luminescence (OSL)</i>	16
3.3	<i>Radon</i>	21
3.4	<i>Emergency preparedness</i>	24
3.5	<i>Radioactive waste</i>	27
<b>4</b>	<b><i>Radioecology</i></b>	<b>30</b>
4.1	<i>Radioecology</i>	31
4.2	<i>Marine tracers</i>	35
4.3	<i>Radioecological models</i>	38
4.4	<i>Contamination physics</i>	46
4.5	<i>Ecophysiology</i>	54
<b>5</b>	<b><i>Radioanalytical chemistry</i></b>	<b>56</b>
<b>6</b>	<b><i>Nuclear facilities</i></b>	<b>57</b>
6.1	<i>Research reactor DR 3</i>	57
6.2	<i>Isotope Laboratory</i>	58
6.3	<i>Waste Management Plant</i>	59
6.4	<i>Educational reactor DR 1</i>	61
<b>7</b>	<b><i>Other tasks</i></b>	<b>61</b>
7.1	<i>Personnel dosimetry</i>	61
7.2	<i>Environmental monitoring</i>	63
<b>8</b>	<b><i>Publications</i></b>	<b>63</b>
8.1	<i>International publications</i>	63
8.2	<i>Danish publications</i>	66
8.3	<i>Publications in proceedings</i>	67
8.4	<i>Publications for a broader readership</i>	71
8.5	<i>Unpublished lectures</i>	72
8.6	<i>Internal reports</i>	76
<b>9</b>	<b><i>Education</i></b>	<b>79</b>
9.1	<i>Ph.D. theses</i>	79
9.2	<i>M.Sc. theses</i>	79
9.3	<i>External teaching</i>	79
9.4	<i>External examiners</i>	79
<b>10</b>	<b><i>Committee memberships</i></b>	<b>80</b>

*10.1 National 80*  
*10.2 International 80*

**11 Personnel 84**

*11.1 Scientists and engineers 84*  
*11.2 Technical staff 85*  
*11.3 Office staff 87*  
*11.4 Ph.D. students 87*  
*11.5 Apprentices 87*  
*11.6 Guest scientists 87*

# 1 Introduction

The Nuclear Safety Research and Facilities Department is engaged in research and development and in the operation of the nuclear facilities at Risø National Laboratory.

In 1997 the department's research and development activities were organized in four research programmes: Reactor Safety, Radiation Protection, Radioecology, and Radioanalytical Chemistry. The radioecology programme was transferred to the department from the Environmental Science and Technology Department on January 1, 1997. Hence closer relations were established between the research programmes at Risø covering nuclear safety, radiation protection, radioecology, and the use of nuclear methods. The nuclear facilities operated by the department include the research reactor DR3, the Isotope Laboratory, the Waste Treatment Plant, and the educational reactor DR1.

The research and development work of the department is carried out in close co-operation with Danish and foreign universities and research institutes and also with the Danish nuclear and radiation protection authorities. The department participates in national and international research programmes including some EU programmes and the Nordic Nuclear Safety Research Programme.

This report presents a summary of the work of the department in 1997 with an emphasis on the results of the research and development activities. Lists of staff and publications are included together with a summary of the staff's participation in national and international committees.

## 2 Reactor safety

In 1997 the work of the Reactor Safety Programme continued to concentrate on reactor physics and severe accident investigations. In addition a new project concerning the decommissioning of research reactors was initiated.

### 2.1 Reactor physics

#### 2.1.1 Calculation of neutron doses to reactor components

The calculations reported last year of the flux distributions in the surroundings of the Forsmark 1 reactor core, performed with standard diffusion theory codes, have been repeated, but by use of the Monte Carlo code MCNP-4A. In the immediate vicinity of the core the two methods give almost identical results, but at large distances, e.g. at the bottom of the steam separator (some 2.5 m of water and steel from the top of the core) the MC calculations give neutron fluxes that are about 10 times higher than those of the diffusion calculations. At the pressure vessel (about 1.0 m of water from the core surface) the MC results are roughly a factor of 2 larger than the diffusion theory results.

An important finding was that the neutron spectra were everywhere quite similar in the two types of calculations, i.e. it is only the amplitudes that differ significantly. This finding is illustrated in Figure 2.1 which shows the 19 group flux spectra at the bottom of the steam separator for both MC and diffusion calculations.

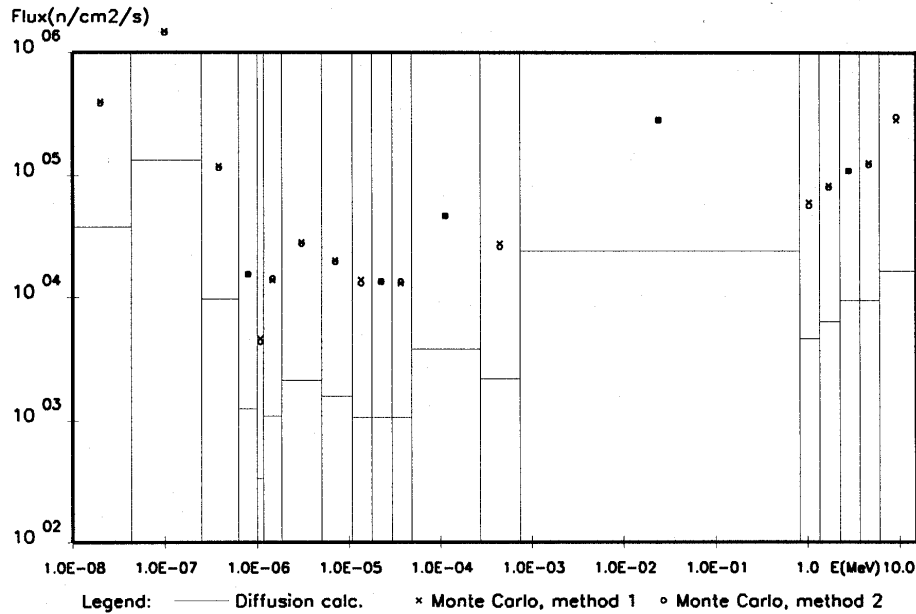

Figure 2.1. Comparison of Monte Carlo and diffusion calculations. Flux spectra in bottom of steam separator.

### 2.1.2 Expansion of the DYNOS code to include neutronics and validation of the updated code

During the past three years the fluid dynamics code DYNOS has been developed. The code is based on a mechanistic 4-equation drift-flux model for two-phase flow and includes a multiplicity of correlations available for the user. The code is especially suited for the simulation of flow in natural circulation BWRs.

The fluid dynamics static part of the code was validated at the Interfaculty Reactor Institute in Delft, the Netherlands, which has an experimental facility, DESIRE, capable of simulating natural circulation flows. The code produced results in excellent agreement with measured data. A static neutronics part, in the form of the COSIMA code, and a dynamic neutronics part, in the form of the point kinetics approximation, was included in the DYNOS code. The updated DYNOS version was then validated against a dynamic benchmark from the NEA comprising measurements from four cycles of the Ringhals BWR. The validation turned out to be successful.

### 2.1.3 Stability investigations on natural circulation BWRs by use of DYNOS

An extensive study has been made of the stability of natural circulation BWRs. The study was focused on three designs, the SBWR and the ESBWR from the GE Company and the SWR1000 from Siemens KWU, with the Ringhals BWR as a reference design.

The relationship between the natural circulation flow rate and the core power was found to be very strong. Parallel channel instabilities was encountered mainly in the ESBWR which has the largest number of channels. Geysing, which is initiated by rapid vapour generation was expected, but rarely encountered in any of the designs. By extensive simulations approximate stability maps were plotted for all the designs considered. Key parameters

affecting the stability of the vessels were identified as the inlet throttle levels, the riser length, the normal water level and the flow resistance of the separators.

### 2.1.4 Calculation of the neutron flux in a horizontal irradiation facility of the DR 3

In the research reactor DR 3 a new horizontal facility for transmutational doping of silicon has been installed.

Before an actual irradiation can take place, the neutron flux along the horizontal tube is measured by 5 beta-emitters, to determine the average flux and thus the irradiation time to obtain a given dose.

The detailed neutron flux distribution in the test tube has been calculated by use of the code system DR3SIM/DIFF2D and comparison with measurements has shown good agreement (see Figure 2.2). The results from the calculation has been used in a spline-interpolation, which can provide a more accurate flux based on the 5 beta-emitters used in the measurements, than a simple average.

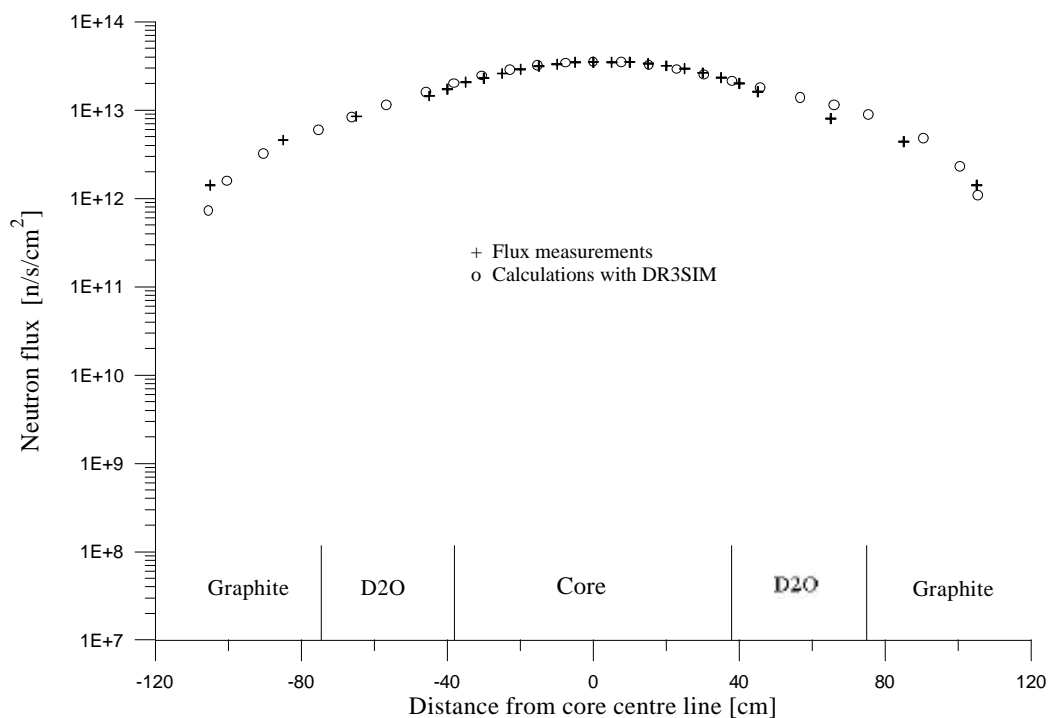

Figure 2.2. Comparison of measurements and calculations in rig 7T2 in DR 3.

## 2.2 Severe accidents

### 2.2.1 Recriticality studies

In special hypothetical reactor accidents a situation may occur, where the reactor core is left uncooled for a time long enough for the control rods to melt and disappear from the core, but not long enough for the fuel to be damaged. Upon reflooding, uncontrolled criticality will occur, possibly with detrimental consequences for the reactor fuel.

The code RECRIT, which was begun in the RAK-2.1 project under the Nordic Nuclear Safety Research (NKS) programme, has been further developed in the EU-project, SARA. It is a fast code, useful for parametric studies in the recriticality field. The code is a stand-alone code that follows the evolution of



the accident from the start. It contains models for all the necessary phenomena, e.g. heating of the core, melting of control rods, as well as dynamic flux and thermo-hydraulic calculations.

In Figure 2.3 an example of the kind of results which can be obtained with the code is given. It shows simultaneous distributions of: Control rod density, void, power, and “ $k_{inf}$ ”, at the time of the first power excursion.

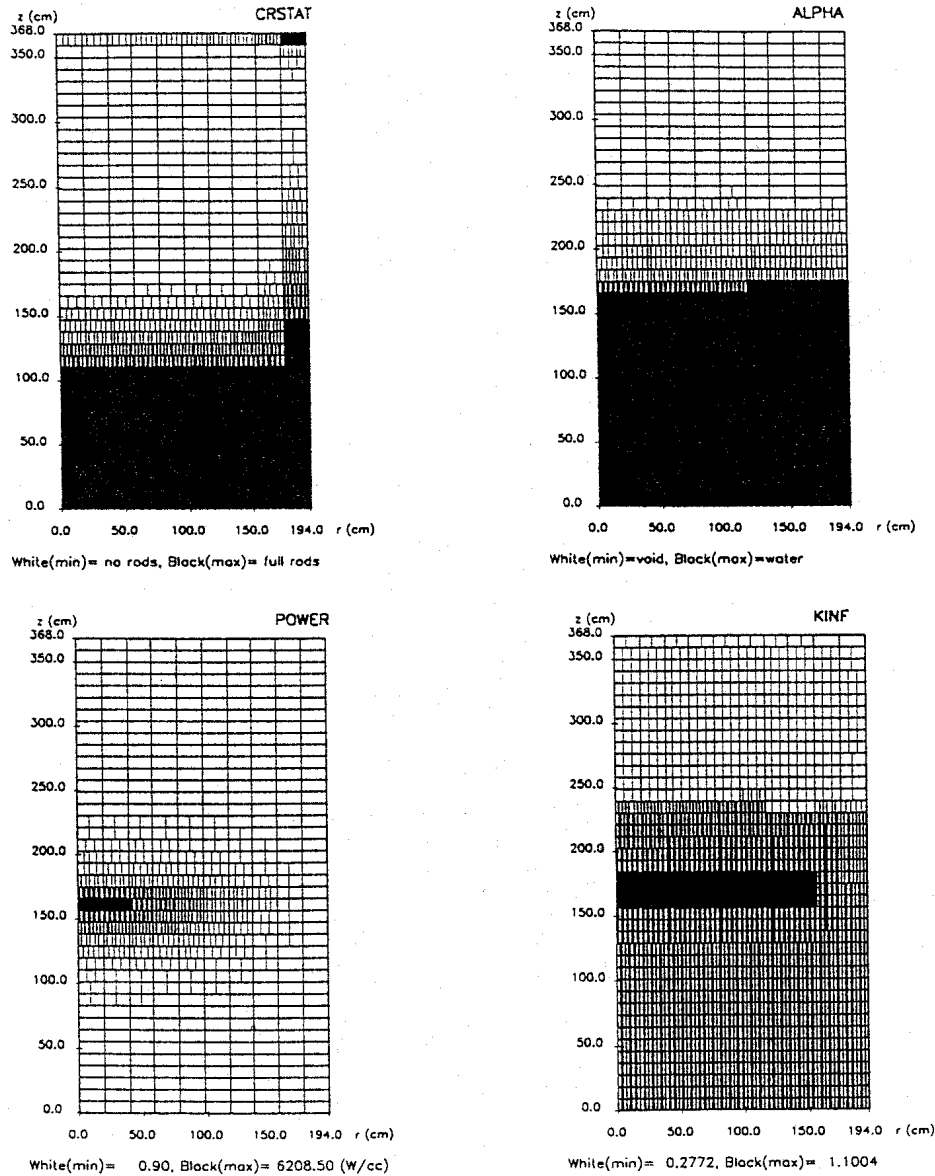

Figure 2.3. Example of calculation with the code RECRIT showing simultaneous distributions of control rod density, void, power and  $k_{inf}$  at the time of the first power excursion.

### 2.2.2 Core meltdown and coolability

The boiling water reactor core meltdown investigations within the RAK-2.1 project under the NKS programme have been completed. Core meltdown may occur e.g. in the unlikely event of a station blackout. The possibility of terminating the core damage progression in the early phases of the accident has previously been investigated. The present investigations are concerned with the

coolability, when the recovery of the injection pump power is delayed until the late phase i.e. until meltdown of the reactor tank, debris relocation to the lower head, and dryout of the reactor tank a few hours into the accident. The computer simulations with MELCOR and MAAP4 performed by the Nordic partners included various scenarios, where vessel failure occurred by lower head creep rupture, penetration melt-through or weld failure with tube ejection. However, the results were very uncertain and the codes did not agree very well.

These results were evaluated, based on a literature study at Risø. This study included the Three Mile Island accident evaluation and vessel investigation projects together with several experimental investigations related to the late phase of the accident. The study involved such phenomena as melt relocation, blockages, molten fuel-coolant interaction, jet fragmentation, and debris bed coolability. It was found that the different models used in the codes were based on rather crude and debatable assumptions which made it difficult to tell whether one of the codes is better than the other.

### **2.2.3 Risks connected to the decommissioning of old nuclear submarines**

As part of an international study on “Cross-Border Environmental Problems Emanating from Defence-Related Installations and Activities” under the NATO/NACC Committee of the Challenges of Modern Society, investigations have been carried out at Risø of the risks involved in the decommissioning of nuclear submarines. In 1997 the available Russian information on decommissioned nuclear submarines and spent nuclear fuel from naval reactors was analysed. Further, a model for calculating the decay heat of submarine reactors was developed. Finally, a simple model for determining the energy production during a destructive criticality accident was improved and compared with a more elaborate Russian model. The two models agreed surprisingly well. Three papers were presented at international conferences.

### **2.2.4 Aerosol resuspension**

In the case of a severe accident in a light water reactor, fission products and structural materials will be released from the damaged reactor core. A significant part of the material will be deposited as particles in the pipes of the reactor coolant system. In a later phase of the accident these particles may be torn loose and become resuspended in the containment atmosphere if the velocity of the steam-gas mixture in the pipes increases. This resuspension can be important for the magnitude of a release of radioactivity to the environment.

A series of experiments on resuspension is performed at the STORM facility at the European Union's Joint Research Centre at Ispra, Italy. A member of the reactor safety group takes part in the experiments and in the analysis.

The resuspension experiments (using SnO<sub>2</sub> as the aerosol material) were continued. One result is that the resuspension takes place in one or more “bursts” as the wind speed in the test pipe increases, possibly stepwise, to a typical value of 100 m/s.

## **2.3 Decommissioning of research reactors**

### **2.3.1 Problems connected to the decommissioning of research reactors**

In 1975 the research reactor DR 2 was closed down and a number of decommissioning measures were performed. In 1997 a planning group was established to look into the future measures that have to be performed in connection with the final decommissioning of the DR 2. The members of the

planning group belong to various programmes at Risø. The group has prepared a working programme which includes collection of relevant information on the DR 2 and assessments of the amounts and types of radioactivity in the DR 2.

A review of the problems connected to the decommissioning of research reactors has been made under contract with the Danish Emergency Management Agency. Visits have been made to Salaspils in Latvia and Swierk in Poland, where research reactors are to be decommissioned or are in the process of decommissioning. The aim of these visits was to investigate the interest in co-operation. A research contract has also been entered with the IAEA on the decommissioning of research reactors.

## **2.4 Nuclear information**

### **2.4.1 Annual report on the international status of nuclear power**

The third annual report in Danish on the international status of nuclear power was published at the beginning of 1997. The purpose of the report is to keep politicians, civil servants, the media as well as other interested persons and institutions informed about the nuclear power development of the world.

### **2.4.2 Reactors in Nordic surroundings**

A four-year project RAK-2 (1994-1997) within the NKS programme has just been finished. The Reactor Safety Programme has been responsible for the subproject RAK-2.3, dealing with information on reactors in Nordic surroundings.

The main objective of the project has been to investigate, collect, arrange and evaluate data of reactors in the Nordic neighbourhood to be used by the Nordic nuclear safety authorities. The importance of such information was recognised after the Chernobyl accident in 1986 and the data provided will help the authorities in giving information to the public in case of an accident in a nuclear power plant neighbouring the Nordic countries.

The project has been an extension of the previous NKS project SIK-3 (1990-1993), where data of selected reactors in Germany, Lithuania and Russia were collected. In RAK-2 reactors in Great Britain has been included as well as satellite reactors. A database has been developed which covers both the reactors of the SIK-3 project and the British reactors. Finally a report has been prepared on reported accidents in nuclear ships - mostly nuclear submarines.

## **3 Radiation protection**

The Radiation Protection Programme works with research and development of instruments and methods for protection against the harmful effects of ionising radiation from both natural and man made radiation sources. The work has been organised in five groups during 1997, encompassing beta dosimetry, retrospective dosimetry, radon, emergency preparedness, and radioactive Waste.

In beta dosimetry the work has been focused on the development of an advanced portable beta spectrometer based on a telescope arrangement of three Si-SB detectors. The spectrometer will be able to measure the energy spectrum of beta radiation in the presence of an intense gamma radiation field. This will make it possible to make an reliable assessment of beta doses to the skin and to

other surface tissues in the event of a radioactive surface contamination of personnel and environment.

The work on retrospective dosimetry is based on optically stimulated luminescence (OSL) using common natural materials like quartz and feldspar as dosimeter materials. The aim is to develop instruments and methods to a highly sensitive technique applicable to retrospective dosimetry in the event of a nuclear accident.

A Ph.D. project on *Radon Transport in Fractured Soil* was concluded in 1997. The study concerned the influence of macropores in clayey till on the transport of radon through the matrix. As part of an ongoing nation-wide radon survey conducted by the National Institute of Radiation Hygiene, Risø is responsible for measurements of radon levels in Danish houses and the measurements of radon emanation rates from 150 Danish soil samples. The purpose is to establish a radon potential map of Denmark.

The work on emergency preparedness has been concerned with the development of a probabilistic approach to derive operational intervention levels for a nuclear emergency. Monte Carlo calculations yielding the joint probability distribution of dose rates and doses averted by sheltering has shown a large variability in avertable doses when this intervention is triggered by a given dose rate measurement in the field. The work, which was sponsored by NKS, may lead to more systematic studies of the optimal strategies for field measurements during a nuclear accident.

Studies concerning long-term properties of conditioned radioactive waste were continued. The main subjects have been water uptake into bituminised waste containing soluble salts and studies of leaching and stability of cemented waste.

## **3.1 Dosimetry**

### **Dosimetry of beta and low-energy photon radiation**

#### **Beta spectroscopy**

Within a joint European research project on dosimetry of weakly penetrating radiation, Risø is developing a portable three-detector telescope beta spectrometer for determination of dose rates in mixed beta/photon radiation fields. By choosing thin detectors as front and middle detector and a thick one as back detector the photon contribution can be essentially rejected on coincidence requirements between the three detectors. In addition to dose determination the information provided by the device on the beta spectrum will also be useful for deciding on adequate shielding or identification of the radionuclide. A prototype of the beta spectrometer (Figure 3.1) has been developed and constructed in co-operation with the Engineering and Computer Department at Risø.



*Figure 3.1. Photo of the Risø spectrometer.*

### **Spectrometer design**

The spectrometer consists of three distinct hardware units: the detector probe, the processing and support unit and the host laptop computer.

The detector probe contains the three silicon detectors arranged in a telescope unit, thermo-electric cooling elements ensuring a constant temperature of the Si detectors under varying environmental conditions, bias supplies, preamplifiers, analog preshapers and circuitry for electrical calibration. Through a 5 m cable the detector probe is connected to the processing and support unit which contains the electronic processing and control components together with battery and power supply. The PC-laptop host is connected to the processing and support unit through a communication interface. The analysis is based on digital signal processing (DSP) at an early stage in the electronic process. All signals meeting certain criteria (minimum amplitude, no pileup) are transferred to the host PC and stored in a format with 256 channels available for each of the three detectors.

All calculation, histogramming and displaying tasks are performed using the commercial software LabView© from National Instruments which is a graphical programming tool providing the interface between the user and the telescope detector. LabView© acts as a “Virtual Instrument” i.e. the computer screen looks and functions like a real instrument. The LabView program will be extended with algorithms to correct the pulse height distribution for the detector response-function (due to backscatter and bremsstrahlung production within the detector), and algorithms to calculate the dose-rate in the measured beta-field.



Figure 3.2. The LabView© front plate is designed to display puls-height distributions for any choice of coincidence mode. In addition a number of control parameters are displayed.

### Initial measurement results

A number of beta energy spectra were obtained for each of the three detectors of the Risø spectrometer to get information on the energy range covered by each detector and thereby the coincidence energy thresholds of the unit. As an example, the beta energy spectrum of Ni-63 obtained by the thin front detector is given in Figure 3.3. This shows the capability of the detector to measure beta energy spectra with energies from 20 to 70 keV. Measurements with a C-14 beta source showed that a minimum electron energy of about 100 keV is required for obtaining energy deposition in both front and middle detector. Similarly, to obtain energy deposition in all three detectors a minimum electron energy of about 250 keV is required.

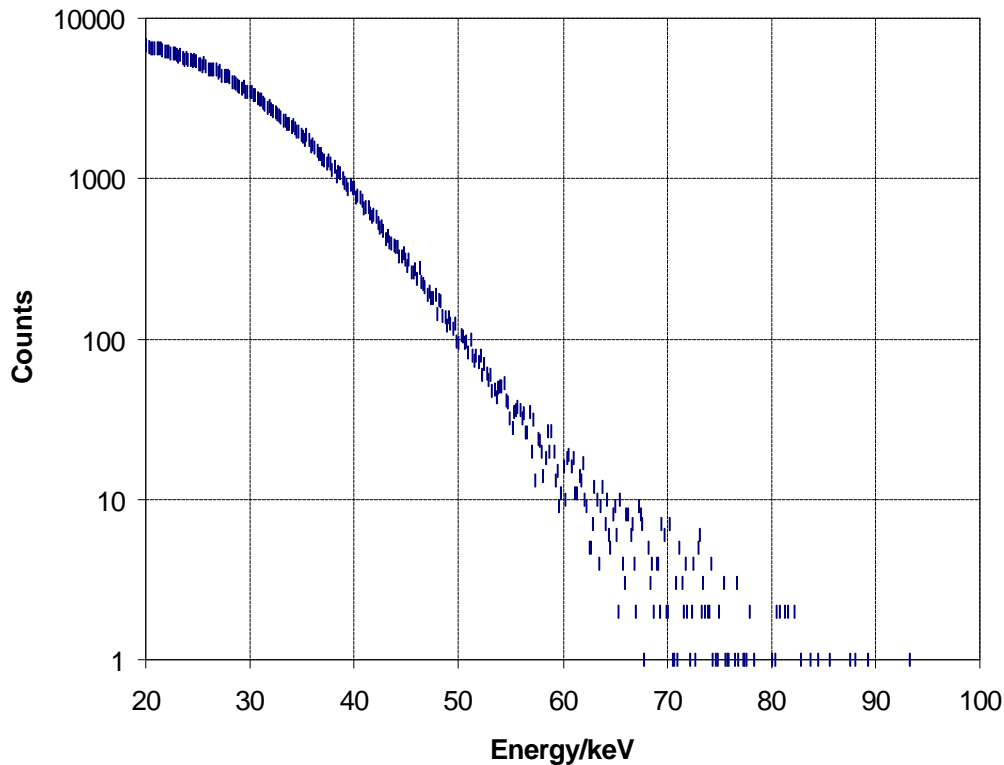

*Figure 3.3. Energy spectrum from Ni-63 ( $E_{max} = 67$  keV) obtained by the front detector of the Risø spectrometer. Background counts (noise) for each channel have been subtracted. Temperature of the detector: 18 °C.*

### **Effect of cooling on silicon detectors**

The effect of detector temperature on noise level and resolution (FWHM) was studied for a number of different detectors. It was found that the noise level decreases 0.3 keV per °C in the range 20 °C to 5 °C and that a decrease in temperature from 20°C to 15°C reduces the FWHM by 10 to 20%. In order to utilize the effect of cooling, the Risø spectrometer unit is provided with a cooling device which can maintain the detector unit at any temperature between ambient temperature and 0°C.

### **Monte Carlo calculations**

MC calculations are used as a support for the development project, e.g. for optimization of the detector combination and for studying the influence of construction material and design on energy distribution and production of bremsstrahlung. Two different MC codes have been applied to verify the reliability of the MC method for this study. At Risø the EGS4 system using the PRESTA algorithm and the DOSRZ code were used to perform simulations of electron and photon absorption in the three detectors of the Risø spectrometer. A series of calculations covering exposure of the detectors with monoenergetic electrons in the energy range from 25 keV to 3500 keV and with photons with energies from 5 keV to 1000 keV were performed.

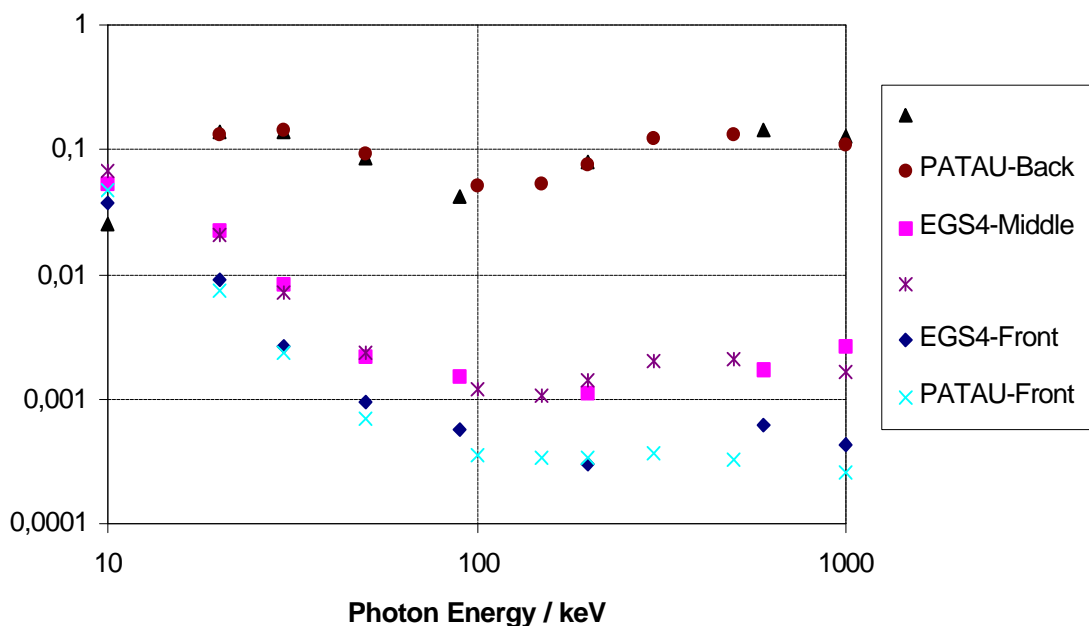

Figure 3.4. Calculated numbers of electrons created in the front, middle and back detector of the Risø spectrometer from exposure to a parallel beam of monoenergetic photons using two different MC codes (EGS4 and PATAU).

Similar calculations have been made at the University of Toulouse where a MC code developed by Patau has been used. Figure 3.4 shows a comparison between data on photons calculated by the Toulouse code and data obtained at Risø. Good agreement exists between the two MC calculations for each of the three detectors. It should be mentioned that the Toulouse data only include energy depositions from photons hitting the detectors, whereas the EGS4 data also include contributions from electrons entering the detectors from the surroundings, i.e. from the walls and from one detector to the other. These results indicate that the energy contribution from electrons initiated by Compton scattering in the surroundings has only limited importance.

### Use of laser scanning imaging for beta dosimetry

The Molecular Dynamics Model 400 Series PhosphorImager™ laser scanning device established at the Risø Physics Department was studied with the aim of dose rate distribution measurements in beta radiation fields. The storage phosphor screen (imaging plate IP) is a position sensitive detector with a dimension of 20 x 25 cm<sup>2</sup>. The resolution of the scanned image is 88 x 88 μm<sup>2</sup>, and the density thickness of the phosphor layer is 40 mg cm<sup>-2</sup>. The IP phosphor is covered by a 1.1 mg cm<sup>-2</sup> protective coating.

A number of dose rate distributions of beta radiation fields were measured and the results were compared with similar results obtained by thin TL detectors. It was concluded that the imaging system presents a promising tool for determination of the dose rate homogeneity of extended beta radiation fields.

### Control of irradiated spices

The dosimetry group assisted the FDB company with TL measurements of five selected samples of spices for irradiation control.



## 3.2 Optically stimulated luminescence (OSL)

Optically stimulated luminescence (OSL) methods have been intensively investigated at Risø with the aim of using this technique in retrospective radiation dosimetry. OSL arises from recombination of charge which has been optically released from electron traps within crystals of quartz and feldspar samples. An immediate advantage of OSL methods over the traditionally used thermoluminescence (TL) method, where the samples are heated, is that OSL is normally measured at or close to room temperature and is thus a less destructive method.

The continued development of OSL for retrospective dosimetry at Risø has in 1997 produced two new powerful OSL units providing enhanced sensitivity. The techniques applied are based on : a) blue-green broad band stimulation light filtered from a halogen lamp using fluid lightguide technology; and b) recently developed bright green and blue light emitting diodes (LEDs). Blue light stimulation of quartz and porcelain was shown to enhance the overall sensitivity of an OSL system by a factor of 8 as compared to conventional green light stimulation.

New OSL measurement protocols were also developed in 1997 for the evaluation of accident doses in retrospective luminescence dosimetry. One method combines single aliquot regeneration and added dose techniques, the so-called SARA method, in an attempt to compensate for any possible sensitivity changes of the OSL signal as a result of reuse of the aliquot. Another method is based on a true single aliquot regeneration technique which in routine use has resulted in a much enhanced precision (from 5-6% previously, now to about 1.5%).

### Development of new OSL instrumentation with enhanced sensitivity

#### *Green light halogen OSL unit*

To improve the signal to noise ratio, a new compact infrared/green light (IRSL/GLSL) OSL unit with much improved sample-to-photomultiplier geometry was developed first. A significantly enhanced GLSL sensitivity was achieved by using liquid lightguide techniques, with halogen light sources for the stimulation of samples. Metal oxide coated UV detection filters further suppressed the background, altogether resulting in an increase in the luminescence output of about a factor 5 compared to that using our previous model.

#### *Blue LED OSL system*

Recently developed bright green and blue light emitting diodes (LEDs) have been tested with the aim of using visible light stimulation of quartz and porcelain in retrospective accident dosimetry. We have identified several practical advantages of using the LEDs over other light sources, e.g. they are inexpensive, heat dissipation is negligible and the power delivery can be easily controlled by software without use of electro-mechanical shutters. We have found that for similar power densities, the higher-energy light provided by the blue LEDs gives a factor of eight greater quartz stimulation rate than that of green light. A schematic diagram of the new blue LED OSL unit is shown in Figure 3.5 and Figure 3.6 shows the OSL decay curves obtained from a quartz sample with an equivalent dose of approximately 100 mGy using (1) the blue LED system (12 mW/cm<sup>2</sup>) and (2) the green light halogen system (25 mW/cm<sup>2</sup>). The effect of using blue light is clearly seen.

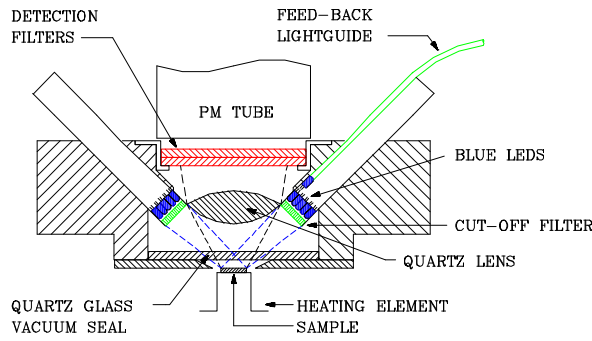

Figure 3.5. The new blue LED OSL unit, schematically.

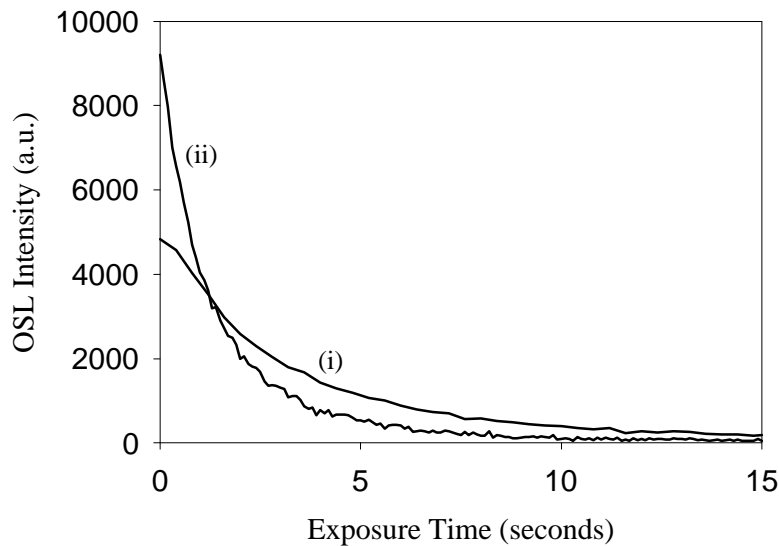

Figure 3.6 . OSL decay curves from a 4 mg quartz sample (brick) with an equivalent dose of 117 mGy using (i) green light stimulation ( $28 \text{ mW/cm}^2$ ) and (ii) blue LED stimulation ( $15 \text{ mW/cm}^2$ ).

Using blue light stimulation on quartz and porcelain significantly increased the rate of decay of the OSL signal due to the higher energy of the light emitted from the blue LEDs. Decay curves obtained from porcelain samples (e.g. from a toilet tank) using (a) a blue LED OSL attachment equipped with 18 diodes providing  $6 \text{ mW/cm}^2$  at the sample, and (b) the standard broad-band green light source providing  $28 \text{ mW/cm}^2$ , show similar shapes (see Figure 3.7). A blue LED OSL system with a larger number of diodes providing more power at the sample was used to measure very dim quartz samples that previously could not be measured using green light stimulation.

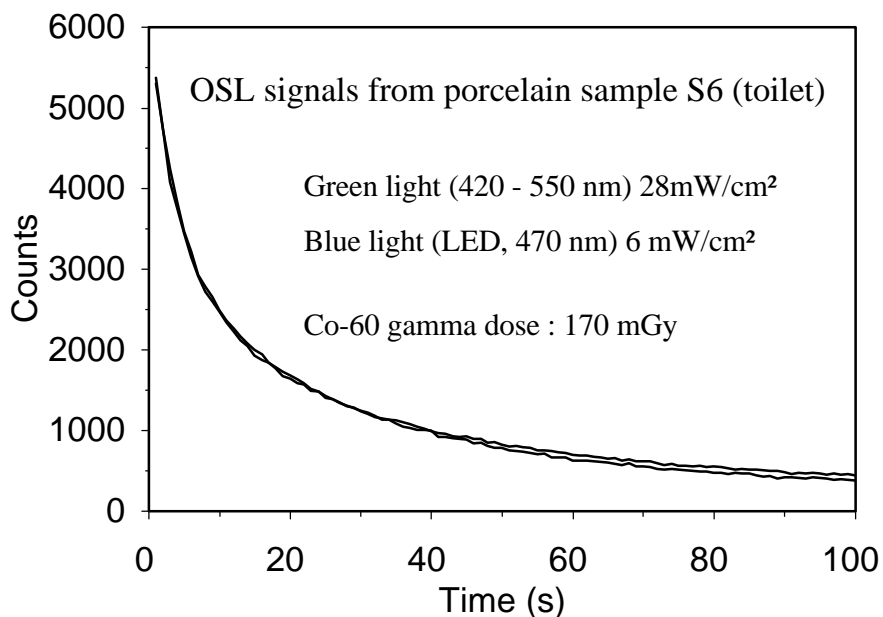

Figure 3.7. OSL decay curves from a porcelain sample (toilet) stimulated with a green light waveband of 420-550 nm (28 mW/cm<sup>2</sup>) and blue LED light of 470 nm (6 mW/cm<sup>2</sup>), respectively. As seen the decay rate is virtually the same in both cases.

#### Laser scanning

A prototype of a high-sensitivity OSL scanning system for measurement of single sand-sized grains was developed that allows a laser spot approximately 200 microns in diameter to be directed at any point on a standard 10 mm diameter aluminium sample aliquot. The design builds on a previous design using a CCD camera, but has a different rationale in that the system is not optimised in order to image luminescence from a whole sample, but to measure the luminescence from individual single grains of a sample. The development of such a system is vital in order to allow the routine measurement of the distribution of grain brightness' and to perform dosimetry on single grains. The system has the advantage that it can be attached directly to a standard Risø automated reader which also provides the ability to heat and irradiate the samples. Preliminary measurements have shown good reproducibility and the distribution of grain brightness' for a variety of samples, including well bleached and poorly bleached sedimentary materials have been measured. Measurements are currently being carried out with the aim of fully documenting the capability of the system.

#### Development of OSL dose evaluation methods for retrospective dosimetry

##### *Single aliquot regeneration added dose (SARA) protocol for quartz*

The SARA method recently introduced by Risø was used to evaluate equivalent doses from materials collected during a field trip to the Chernobyl areas in Ukraine and Russia in 1997. The SARA OSL method is based on a combination of single aliquot regeneration and added dose techniques with the aim of using the advantages of single aliquot measurements and at the same time compensate for sensitivity changes of the OSL signal which may be associated with the re-use of aliquots. SARA results show consistency with those obtained with other

techniques and have demonstrated our ability to compensate for sensitivity changes (see Mejdahl and Bøtter-Jensen, 1997).

*Single aliquot regeneration (SAR) OSL protocol for extracted quartz from bricks*

Normally multiple-sample added-dose or regeneration techniques (including SARA) have been used for the evaluation of accident doses in luminescence dosimetry. More recently we introduced the single aliquot regeneration method which has improved the OSL measurement precision significantly. Single aliquot methods have the following advantages which are of particular importance for retrospective luminescence dosimetry using natural materials: 1) high precision (typically 1-3% using few aliquots), 2) very small samples can be used, 3) rapid measurement allow a considerable number of samples in a reasonable time and 4) no corrections for supralinearity are needed. The single aliquot method has been used extensively at Risø to measure samples from recent field trips in Russia and Ukraine with excellent results. The single aliquot regeneration protocol used is shown schematically in Figure 3.8.

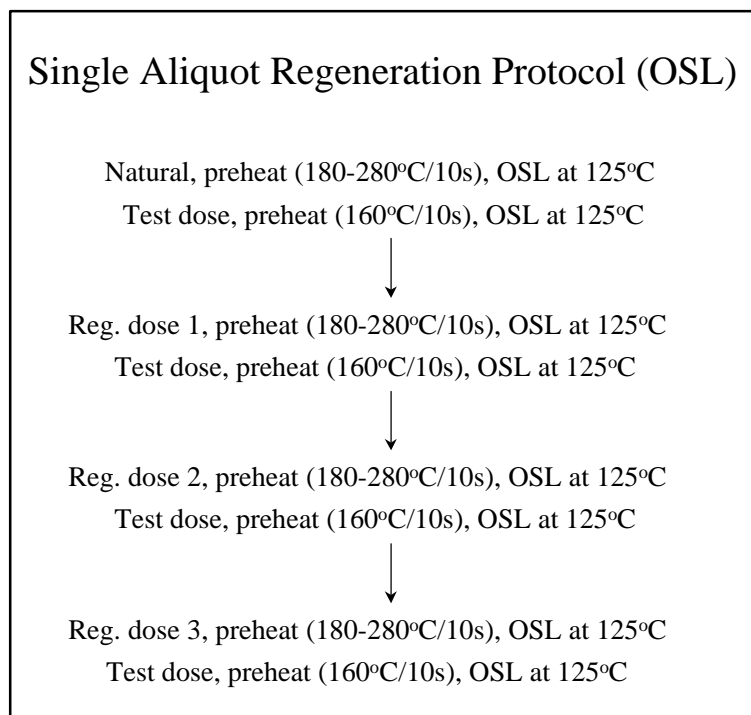

Figure 3.8. The single aliquot regeneration protocol, schematically.

*Temperature dependence of OSL decay curves*

In a collaboration between Risø and the Oklahoma State University the factors which affect the shape of OSL decay curves were examined, both experimentally and theoretically, in an effort to understand and describe the behaviour of OSL as a function of temperature. The normal procedure for recording OSL during retrospective dosimetry applications using natural materials is to record the luminescence as function of time at room temperature. Several processes were seen to affect the behaviour of OSL curves as function of temperature, depending upon the precise mechanism by which the OSL is produced. Overall, we conclude that the decay shape is dependent upon the sample, the illumination intensity and the sample temperature. Also the various mechanisms and processes that can lead to OSL and how each of these effects

are dependent upon temperature have been investigated. Attention was focused on natural feldspar and quartz (see McKeever et al, 1997).

#### *OSL on tooth enamel for possible use in retrospective dosimetry*

The question arose whether OSL could be used with tooth enamel in retrospective dosimetry. Risø initiated the testing of the OSL signals that could be obtained from tooth enamel using different stimulation light sources. Crushed tooth enamel samples, previously used for ESR dosimetry, were kindly provided by Institute of Semiconductor Physics, Kiev. Although the observed OSL signals were weak, we found a clear dose dependence but large scatter between samples. Preheat was found to have a crucial effect on the OSL signal. Doses of the order of 50 Gy could be clearly distinguished using green light stimulation and preliminary measurements indicate a lower detection level of about 5 Gy. Figure 3.9 shows typical OSL decay curves obtained from tooth enamel samples stimulated with green light (420-550 nm). Blue light stimulation still has to be tested with tooth enamel.

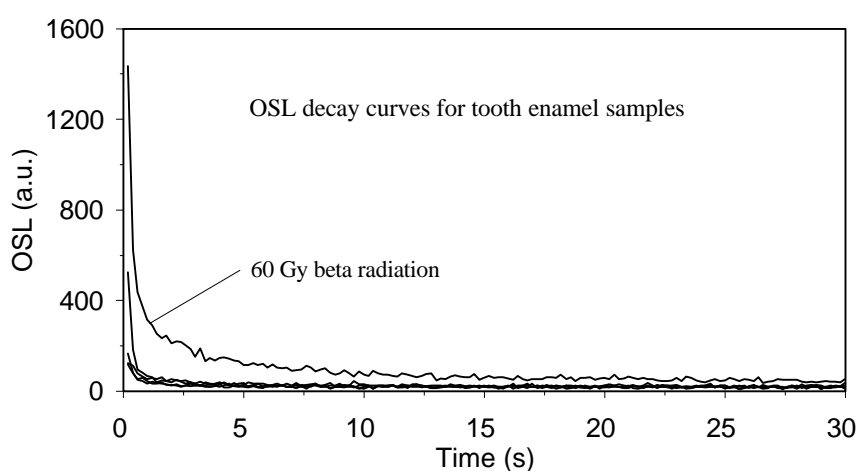

*Figure 3.9. Typical OSL decay curves obtained from 10 mg tooth enamel samples exposed to Sr-90 beta irradiation using green light (420-550 nm) stimulation delivering 28 mW/cm<sup>2</sup> at the sample.*

#### **Results from measurements of field samples**

##### *Low-dose intercomparison of results from field samples collected in 1995*

Quartz samples and porcelain discs irradiated to 300 mGy Co-60 gamma radiation were used to calibrate a 5 mCi beta source attached to the Risø TL/OSL system. Subsequently three different brick fractions and two porcelain samples collected in Chernobyl were circulated between the participating laboratories as part of an intercomparison. These samples were measured using OSL with green light stimulation (420-550 nm). Several quartz coarse grain samples were extracted from each brick to determine the depth dose profiles. The porcelain discs were also measured using green OSL. The Risø OSL results agreed very well (within 5%) with the average values determined using TL by the other participating laboratories. Typical OSL decay curves from a porcelain sample stimulated with green and blue light are given in Figure 3.7.

##### *Measurement of samples collected during field trips in 1997*

The recently developed single aliquot regeneration protocol was used for the measurement of the most recently collected samples during field trips in Russia and Ukraine in 1997. The new OSL stimulation light sources were also used and overall a marked improvement with regard to sensitivity and precision was obtained compared to earlier methods. e.g. using 10-12 aliquots (4 mg) of a single sample, a typical standard error of 1.5% was obtained for a quartz sample with an equivalent dose of approximately 100 mGy. Depth dose profiles obtained from three different bricks are shown in Figure 3.10. The relative accuracies are of the order of 1.5%, even in the case of doses as low as 100 mGy which is the approximate dose expected to be received by a brick over 30 years from the natural background radiation.

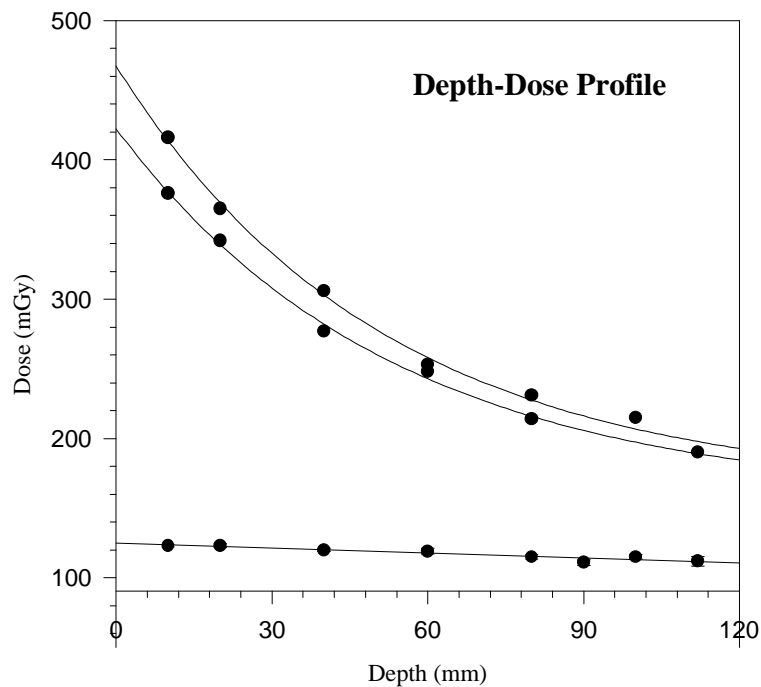

Figure 3.10. Depth dose profiles obtained using extracted quartz from different bricks collected during field trips in Russia and Ukraine and using the OSL single aliquot regeneration method. The error bars are within the symbols.

### 3.3 Radon

#### Radon transport in fractured media

A Ph.D. project entitled *Radon Transport in Fractured Soil* was concluded in 1997. A soil-column experiment performed in collaboration with the Geotechnical Institute confirmed that soil-gas flow through clayey till is dominated by preferential flow through macropores (see **Error! Unknown switch argument.(A)**). This is in line with the recent discovery that soil structures of clayey till offer little protection for ground-water reservoirs against pesticide contamination. More surprising therefore, was the finding that the existence of such macropores did not change the availability of radon beyond the increase of the gas permeability. This is shown in **Error! Unknown switch argument.(B)**. In short, it was demonstrated that the rate of degassing of radon

by air flow through the macropores was as high as the rate of degassing observed in the laboratory when the sample was dismantled. Since radon is generated in the matrix of the soil, it was expected that preferential flow would have lead to a marked decrease in the rate of degassing. These results are important contributions to the general understanding of flow of soil gasses. In particular, they help to understand why radon levels in Danish houses on clayey till are relatively high. Other aspects of the work have lead to improvements of how radon transport in soil can be modelled.

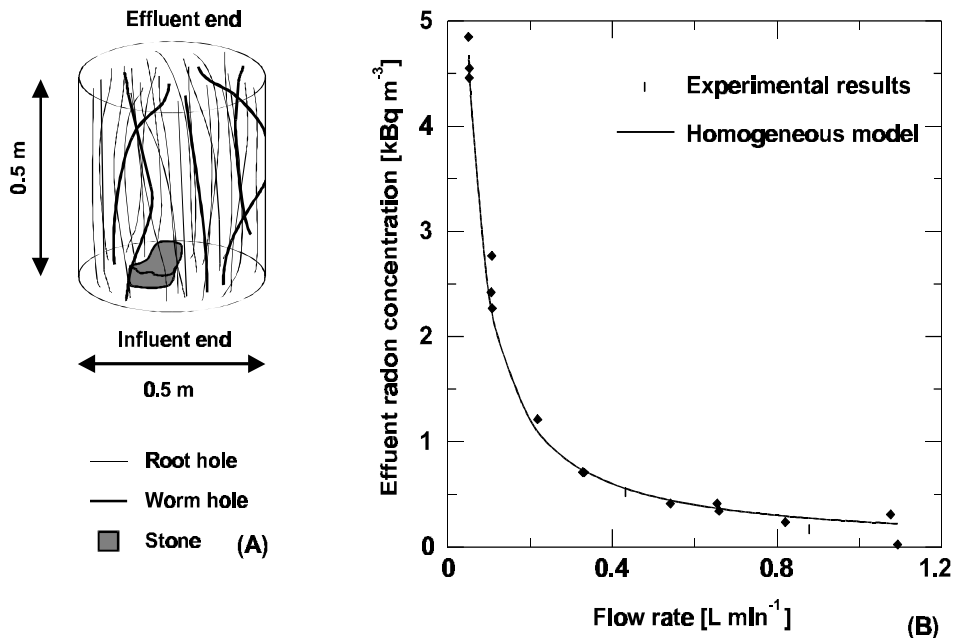

### National survey of indoor radon levels

A new nation-wide survey of radon levels in Danish houses is under way. The project is lead by the National Institute of Radiation Hygiene. Risø is responsible for radon measurements and part of the data analysis. The Geological Survey of Denmark and Greenland also participates in the project. The main purpose of the project is to obtain a more accurate estimate of the number of houses with high levels of radon (e.g. above 200 and 400 Bq/m<sup>3</sup>). Other purposes are to identify possible high-level areas and to investigate if there has been a change of radon levels since the first Danish survey was conducted in 1985/86.

Measurements were conducted in more than 3000 houses (both single-family and multi-family houses). Approximately 10 (random) houses were selected in each of the 275 Danish counties (Danish: *kommuner*). This will permit the making of a map of Denmark showing radon levels county by county.

Risø's alpha-track detectors have been applied in the survey. Detectors were placed in the living-rooms of the houses in the end of 1995. After one year of

exposure, detectors were retrieved in late 1996. In 1997, detectors were read out in the laboratory. Currently the data are being analysed.

### **Radon-emanation rate measurements**

Accurate measurements of the radon-emanation rate of soil samples is important for many studies relating to radon in soil (see for example *Figure 3.11*). In 1995, Risø implemented a standard procedure for such measurements and analysed about 100 Danish soil samples obtained by the Geological Survey of Denmark and Greenland (GEUS). In 1997, GEUS initiated a new project where Risø in 1998 is to measure about 150 additional samples. The purpose is to make a radon potential map of Denmark based (mainly) on geological parameters.

Risø's technique of radon emanation-rate measurements is sketched in *Figure 3.12(A)*: A sample is placed in a closed chamber with no radon activity. Over a period of a few weeks, the ingrowth of radon is followed in the chamber by means of scintillation cells (*Figure 3.12 (B)*). From the mass of the sample and the size of the chamber, the radon emanation rate can be calculated. The technique requires that the sample is greatly disturbed such that radon can easily diffuse out of the sample. The disturbance of the sample does, however, not necessarily leave the emanation-rate unchanged. For example, dismantling the sample is bound to change grain-to-grain distances as well as the distribution of moisture within the sample.

In 1997, experiments were conducted to get a better grip of these potentially important sources of error. Eight intact clayey-till samples obtained in 1994 from the site of Risø's radon test structure site were analysed. Samples were dismantled and the standard emanation-rate measurement procedure was applied. The results are shown in *Figure 3.12(C)*. The samples were then dried in an oven and water was added by pipette (although spraying had probably been a better procedure). Emanation rate determinations were conducted from zero moisture to saturation as shown in *Figure 3.12(D)*. The emanation rate were quite different from sample to sample. For example, at about 10 % moisture, the emanation rates ranged from 6 to 19 atoms per kg dry mass per second. The emanation results for each of the samples shown in *Figure 3.12(C-D)* have been normalised by these values.

*Figure 3.12(D)* shows that moisture has an important effect on the radon emanation rate of such samples: Adding about 2 % of water to an oven-dried sample on the average increases the emanation rate by more than 60 %. There seems, however, to be little importance of adding water above that level. A comparison of *Figure (C)* and *(D)* shows that the sample does not return to the "natural moisture" condition by simply adding water to an oven-dried sample. On the average, the emanation rate of samples in the natural moisture condition is 12 % higher than that of the oven-dried samples with similar water content. Considering that oven drying is a very substantial disturbance of the sample, this experiment could indicate that the change in emanation rate from the (true) natural environment to the dismantled sample is probably not much larger than about 10 %.



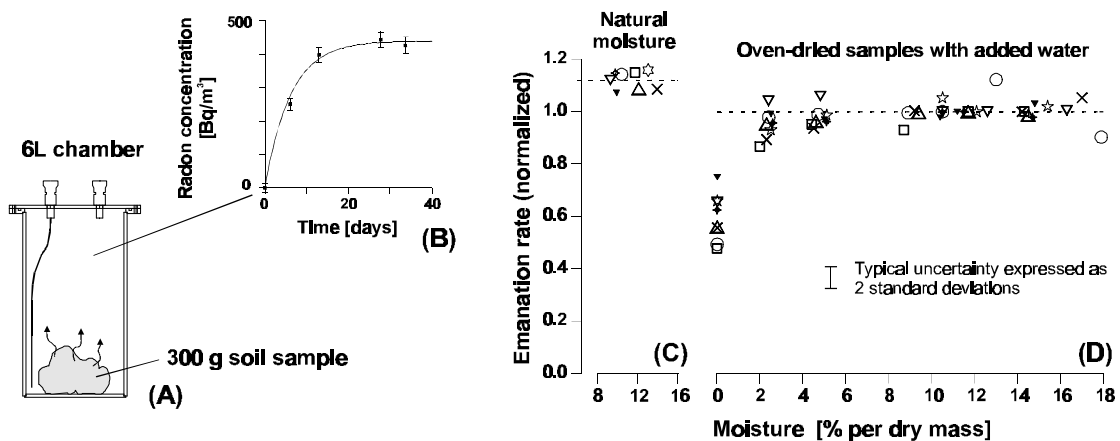

Figure 3.12. (A) In Risø's standard procedure for radon emanation rate measurements a sample of soil is placed in a closed 6L chamber. (B) The ingrowth of radon in the chamber is then followed over time. (C) and (D) show results for eight samples as discussed in the text.

### Participation in 2 EU concerted action projects

In 1997, an EU project called *European Research into Radon in Construction Concerted Action* was initiated. The project is lead by the Building Research Establishment in the UK and has participation of more than 26 European laboratories. The main objective of the project is to ease the communication of research results and other technical aspects of radon in houses. The project is divided into five topics. Risø leads the topic on modelling.

Risø also participates in the organisation of an EU project concerning intercalibration of integrating radon dosimeters. The project is lead by the National Radiological Protection Board in the UK. The main purpose of the project is to define and organise yearly intercalibration exercises during 1997 - 99. The participating laboratories in the 1997 exercise were ranked according to the deviation of the reported results from the true value as well as the variability of results. Risø was ranked number three out of 62 laboratories.

### Building-material exhalation measurements

On request from a Danish producer of building materials, steps were taken in 1997 to establish a measurement protocol at Risø for measurement of exhalation rates from building material samples. Two methods are under investigation: one in which the exhalation rate is measured at near-zero concentration conditions (similar to the Danish standard for degassing measurements of other pollutants from building components) and another where the exhalation is measured in accumulation mode. The project will be reported in 1998.

## 3.4 Emergency preparedness

### NKS project: A probabilistic approach to derive operational intervention levels for a nuclear emergency.

Operational intervention levels (OILs) are defined as the predetermined values of environmental measurements above which protective actions should be carried out in emergency exposure situations. In particular, dose rate measurements are of interest for urgent countermeasures, since they are

commonly accessible and may provide for a rapid, if provisional, estimate of the radiological consequences of an ongoing nuclear accident.

As part of the EKO-3.3 project under the Nordic Nuclear Safety Research programme (NKS), a probabilistic approach to derive OILs was undertaken. Because urgent protective actions are introduced at a time when information about the scale and severity of the accident is very limited, OILs should be evaluated in a probabilistic setting, reflecting the general uncertainty related to the progression of the accident. In the probabilistic approach, the many variables describing all processes from release of radionuclides, atmospheric transport, to the final exposure of people are allowed to fluctuate, rather than attaining single point values. The parameter fluctuations have their origin, partly in a genuine uncertainty due to incomplete information, and partly in the inter-individual variability of e.g. access to adequate protection.

In Figure 3.13 the result of a Monte Carlo calculation of dose rates and doses averted by sheltering is shown. The stipulated accident involves loss of coolant, core melt and breach of containment. Each dot in the figure corresponds to a definite choice of parameters and the density of dots gives the joint probability distribution of dose rates and avertable doses. The large variability in avertable dose is evident from the figure and, it is clear that there is no one-to-one correspondence between dose rates and avertable doses.

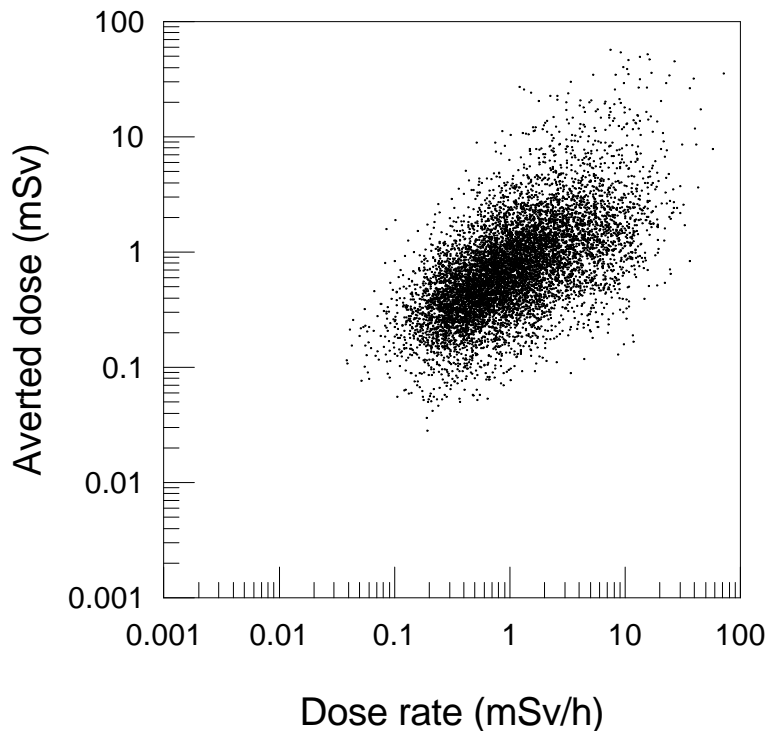

*Figure 3.13. Joint probability distribution for sheltering at 20 km distance following a severe accident at a nuclear power plant. The variability is due to the distribution of parameter values describing all processes from release to radiation exposure.*

From the joint distribution OILs can be derived. Optimized OILs are given by the (dose rate) measurement value, for which the average avertable dose is equal to the chosen intervention level. The optimized OILs are shown to depend both on accident scenario as well as on distance from the plant. Typical dose rate OILs for sheltering are found to be in the range of  $d_{OIL} > 1$  mSv/h for

distances larger than 5 km, i.e. values that are an order of magnitude larger than values adopted in Nordic and international emergency preparedness planning.

The probabilistic approach may be developed as a tool for optimizing existing and future measuring strategies. Site-specific calculations will be needed to take into account local differences in assumed source terms, effectiveness of countermeasures as well as differences in measurement strategies. Due to the site- and scenario dependency, intervention guidelines in form of OILs may only be harmonized at the expense of local optimization.

### **Services for the Danish Emergency Management Agency**

#### *Test and calibration of early warning stations for Eastern Europe(EWS-East).*

The Emergency Management Agency has established a number of early warning stations in the Baltic countries, Poland, and Russia aimed at the detection of radioactive contamination of the environment. Risø has tested the various functions of a prototype of the measuring stations and calibrated its radiation detectors.

The sources used for the calibration were Ra-226, Co-60, Cs-137 and I-131. The activities were in the range of 35 - 300 MBq. The sources were mounted on a small sledge, which was pulled by a motor driven winch system in steps of 0.33 m every 30 minutes. Several series of measurements were taken with each source in two different directions ( N-S and E-W) over a range of 0 - 20 m from the station. As a result the resolution of the detector and the sensitivity for a uniform surface contamination have been evaluated for the sources in question.

In addition to the calibration of the EWS-East, Risø has evaluated parts of the software and the documentation for the measuring stations.

#### *The Danish early warning stations (EWS-DK)*

The 11 measuring stations under the EWS-DK system continued to run smoothly with only a limited number of technical malfunctions, primarily transmission errors. Three new countries ( The Czech Republic, France and Switzerland ) joined the European Union Radioactivity Data Exchange Platform in 1997, increasing the number of early warning stations in the European system from 533 to 939. Data from all stations are once a week sent to Ispra in Italy. All data from the 17 countries are returned to all participants. The format of the data is different from country to country. At Risø all the data are transformed to a common format. In case of a nuclear accident the data exchange rate could be increased to several times a day.

The central computers in the EWS-DK system has from its start in 1989 been running on 2 Unix computers. During the last two years converted programs has additionally been running on a Windows NT platform. This includes the data collection from individual stations, evaluation of the spectra and servicing of the alarm monitors. The aim is to rely entirely on the NT platform in the future.

A recent development is a coupling to the EWS-East data base system. Data from the Danish stations are converted to the EWS-East format although all the data items are not identical. The NaI(Tl) spectra are resampled from 256 channels to 512 channels moving the Tl-208, 2614 keV peak from approximately channel # 125 to channel # 450. Some problems related to error messages and spectrum analysis still remains to be solved.

#### *Exercises*

On April 17 Risø together with the Emergency Management Agency took part in exercise INEX-2-FIN. The exercise dealt with an accident at the Finnish

Nuclear Power Plant Loviisa. 26 countries in Europe, America and Asia participated in the exercise. The main purpose was information exchange.

On November 6 Risø together with the Emergency Management Agency took part in a small exercise dealing with an internal accident at the Barsebäck Nuclear Power Plant. There was no release anticipated from the plant and the main purpose of the exercise was to respond to input coming from Sweden.

### **Risø's emergency preparedness**

A modernisation of the equipment for Risø's mobile measuring teams has been considered and a portable measuring station has been studied. The main features of such a station will be:

- Measurement of environmental gamma ray spectra using either a NaI(Tl) or a CsI(Tl) detector.
- Measurement of environmental dose rate using either the above mentioned detector or a separate Radoz GM-system.
- Recording of the position using a GPS device.
- Display of actual position and dose rate on a map.
- Communication link to a central computer

A prototype is assembled and software for the station is partly finished. Modules for display of maps and positions are ready while some work on the spectral analysis remains.

## **3.5 Radioactive waste**

Experimental studies concerning long-term properties of conditioned radioactive waste or cementitious barrier materials as used in disposal facilities have been conducted at the Waste Management Plant for many years. Experimental work and modelling within these or related areas maintain the professional standard and the international relations considered important also for practical waste management, see Section 6.3. In the last 3 years the studies have been part of the Radiation Protection Programme, but from 1998 they will be transferred to the Radioecology Programme.

A considerable part of the work is carried out within the EU Nuclear Fission Research Programme or the Nordic Nuclear Safety Research programme NKS.

### **Bituminized waste**

Water uptake into bituminized waste containing crystals of soluble salt (sodium nitrate or sulphate) has previously been studied under an EU contract. Additional studies were carried out by an American Ph.D. student to verify that leaching of radioisotopes (of Sr, Cs and Pu) can be interpreted as a result of releases into the porous structure resulting from such water uptake. At least for materials with relatively coarse crystals this seems to be the case. Other interaction phenomena were also investigated. The behaviour of plutonium was studied for 'real' samples of Risø bituminized waste containing plutonium as discussed below. The leach rates were found to be low.

A source-term model based on the water uptake and swelling concept is under development.

## Cemented waste and concrete barriers

Extensive studies of leaching and stability of various types of cemented waste were carried out under previous EU contracts. A one-dimensional numerical diffusion model has been set up and used to simulate leaching experiments with cemented waste as performed at Risø. It should be relatively easy to extend this model to general release behaviour in multibarrier systems and then for use in generic safety assessments of repositories. Simultaneous transport of radioisotopes and important major ions such as  $\text{Na}^+$ ,  $\text{NO}_3^-$  or  $\text{OH}^-$  are included, which makes it possible to simulate temporary effects of the leaching of soluble salt or depletion of  $\text{OH}^-$  from the cement.

During the first year of a new EU contract work was carried out on transport of radioisotopes through cracks in concrete exposed to a flow of groundwater. This is in continuation of previous studies of crack filling in concrete where the final EU report recently became available. In the new experiments it was demonstrated that strontium isotopes closely follows the behaviour of calcium in such systems, see Figure 3.14. The influence of the presence of corroding iron inside the crack (i.e. drum surfaces) was also investigated but found to be of secondary importance.

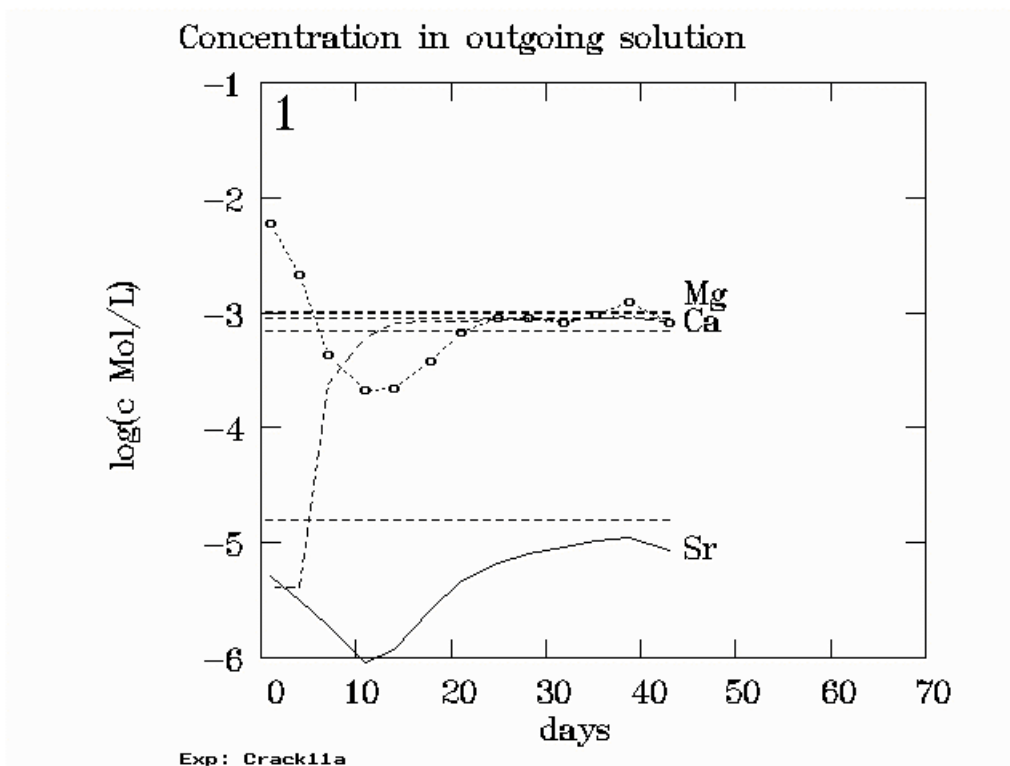

Figure 3.14. Concentration of calcium, magnesium and strontium (from  $^{85}\text{Sr}$  measurements) in out-flowing solution from a cracked cement mortar specimen. The horizontal lines indicate the concentrations in the feed solution.

The pseudo 2-dimensional CRACK2 model of transport and filling with calcite of cracks in concrete have been generalised in various manners. Besides the macro-chemistry it now handles the behaviour of one or two radioisotopes present in the concrete or entering with the calcium bicarbonate solution simulating groundwater.

A series of experiments with flow of pure water through two types of highly porous cementitious backfill materials was also performed verifying that the experimental method was applicable. It is too early to draw conclusions from these experiments.

### Radioactivity in Risø waste products

The scanning facility used to measure contents of long-lived  $\gamma$ -emitters in Risø waste (mainly  $^{137}\text{Cs}$ ) was described in last year's annual report. In 1997 a series of  $\alpha$ -analyses of older samples of bituminized evaporator concentrate was reported. The analyses were carried out with support from the Emergency Management Agency.

The aim of the study was to establish a typical level for plutonium and investigate the so called scaling factor correlation between  $^{137}\text{Cs}$  and plutonium contents in this waste. Most of the long-lived radioisotopes originates from the Risø Hot Cells where characterization work on experimentally irradiated power reactor fuel pins was carried out from 1965 to 1990. Waste from this type of work could be expected to show a  $^{239-240}\text{Pu} / ^{137}\text{Cs}$  activity ratio of about 0.0076 after correction for decay back to the time of removal from the reactor. The analytically determined ratio is a factor of about 1.6 lower as illustrated by Figure 3.15. This is not surprising because the cesium is more mobile in the waste water collection system than plutonium which would tend to remain fixed to solid surfaces.

The plutonium contents were in all cases one to two orders of magnitude below the 400 Bq/g generally considered limit for the mean value in significantly  $\alpha$ -contaminated waste.

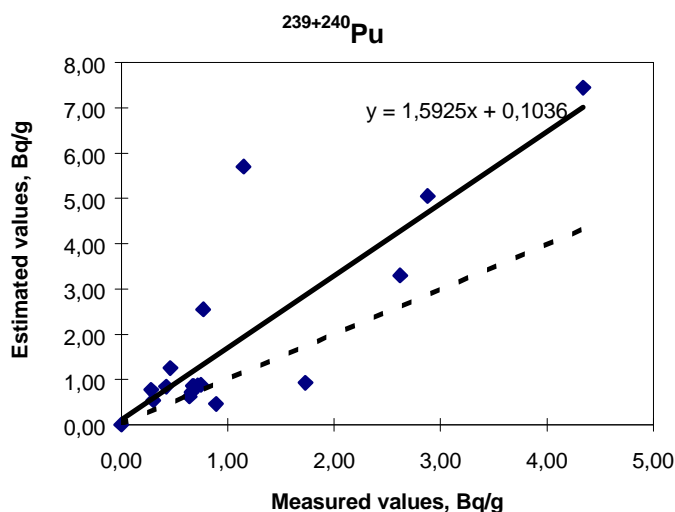

Figure 3.15. Plot of the expected versus the measured  $^{239-240}\text{Pu} / ^{137}\text{Cs}$  ratios in bituminized waste products produced at Risø from 1983 to 1993. The stippled line shows the slope equal to one.

### Contributions to NKS-AFA

Nordic practices concerning characterization and activity determination in waste units, planned or actually used disposal practices, methodology used in safety assessments, and form and contents of the Environmental Impact Statements needed in connection with siting and construction of new disposal facilities were reviewed within the NKS-AFA project. Staff from the Waste Management Plant contributed information about the Danish situation and descriptions and comments concerning the general state of the art within these areas. The final AFA report will be available in 1998.

## 4 Radioecology

By January 1, 1997 the Ecology Programme was transferred from the Environmental Science and Technology Department to the Nuclear Safety Research and Facilities Department. At this occasion the project on Biosphere Atmosphere Exchange remained in the Department for Environmental Science and Technology, now: Plant Biology and Biogeochemistry Department.

The aim of the reorganized Ecology Programme is to improve our understanding of the bio-geochemical behaviour of radioactive, as well as stable elements. Furthermore, the purpose is to develop methods which can reduce environmental and radiological impacts from pollutants, and utilize radioecological principles and measuring methods to solve general environmental problems.

It is furthermore an obligation for the Ecology Programme to maintain and develop a radioecological expertise in order to assist the Danish Nuclear Authorities with advise and laboratory assistance.

Forty years experience in the measurements of environmental radioactivity has placed the programme in a favourable position with respect to low level radioactivity measurements and radiochemical analysis. A further development of our analytical capacity was made in 1997; in a cooperation with the Plant Biology and Biogeochemistry Department we have by ICPMS succeeded to determine  $^{239}\text{Pu}$ ,  $^{240}\text{Pu}$  and  $^{237}\text{Np}$  in environmental samples. This is of great interest for our ongoing programmes in the Urals (see 4.1.2) and in Thule (4.2), as isotope determinations of plutonium are an essential tool for source identification in environmental samples.

The programme has as previously been deeply involved in international cooperation. In a study of radiation doses received from contamination of skin and clothing it was shown that the skin beta dose in some of the highly contaminated areas after the Chernobyl accident might have been several Sv. I-131 has the highest relative importance in connection with all dose contributions related to skin contamination after Chernobyl. Radiocaesium comes next in importance (4.4).

In an EC project an assessment of the radiological consequences of dumped nuclear reactors in the Kara Sea has been carried out in an international cooperation. The predicted collective dose is about 1 man sievert and does most probably not exceed 100 man sieverts (4.3.1).

Finally, the programme has continued its ecophysiological research focusing on studies of Cu-metabolism in rainbow trout and gill lipid metabolism in eels (4.5). We have shown that Cu-acclimation results in an increased clearing of plasma Cu, primarily to the liver, most marked during the first 12 h of exposure.

## 4.1 Radioecology

### 4.1.1 Transfer coefficients obtained from AMAP

The AMAP (Arctic Monitoring and Assessment Programme) has finalized its report on Radioactive Contamination. Risø has contributed with the calculation of transfer coefficients to selected arctic products based on the data obtained from the eight Arctic countries participating in AMAP.

Summarized below is a compilation of the transfer coefficients and a discussion of the observed differences between the various areas.

The integrated transfer coefficient is the infinite time integral of the radionuclide concentration in a sample, e.g.  $^{137}\text{Cs}$  in lichen (unit:  $\text{Bq } ^{137}\text{Cs kg}^{-1}$  year), divided by the deposition of the radionuclide in the area from where the sample is obtained (unit:  $\text{Bq m}^{-2}$ ). The unit of the integrated transfer coefficient thus becomes:  $\text{year} \cdot \text{m}^2 \cdot \text{kg}^{-1}$ .

In the AMAP study measurements of radionuclide concentrations are available mostly for the period 1960-1994. For the years 1951 to 1959 (radioactive contamination of the environment started around 1950) the time integral is obtained from the level measured in 1960 assuming a linear increase from zero in 1951. From the years after 1994, it is assumed that the effective half-life of  $^{137}\text{Cs}$  and  $^{90}\text{Sr}$  in the arctic environment is 10 years.

Table 4.1 and Table 4.2 show comparisons between time-integrated transfer of  $^{137}\text{Cs}$  and  $^{90}\text{Sr}$  to lichen in Greenland, arctic Russia and arctic Finland ( $^{137}\text{Cs}$  only). The transfer coefficients of  $^{90}\text{Sr}$  are lower to lichen in Greenland than in arctic Russia, and of  $^{137}\text{Cs}$ , lower to lichen in Greenland than in arctic Russia and arctic Finland. Furthermore, for Greenland and Russia, the transfer coefficient of  $^{137}\text{Cs}$  is almost 2-3 times higher than that of  $^{90}\text{Sr}$  which is consistent with the known ability of lichen to intercept and retain radiocaesium for longer than radiostrontium.

Table 4.1. Integrated transfer coefficients for  $^{137}\text{Cs}$  to arctic lichen ( $\text{Bq/kg y}$  per  $\text{Bq/m}^2$ ).

Area	Integrated deposition ( $\text{Bq/m}^2$ )	Time integrated concentration ( $\text{Bq/kg y}$ )			Integrated transfer coefficient
		1950-1959	1960-1994	1995-	
Arctic Finland	2500	3100	31000	10000	18
Greenland	4300	4800	25000	1700	7
Arctic Russia	3100	6000	18500	3000	9

Table 4.2. Integrated transfer coefficients for  $^{90}\text{Sr}$  to arctic lichen ( $\text{Bq/kg y}$  per  $\text{Bq/m}^2$ ).

Area	Integrated deposition ( $\text{Bq/m}^2$ )	Time integrated concentration ( $\text{Bq/kg y}$ )			Integrated transfer coefficient
		1950-1959	1960-1994	1995-	
Greenland	2700	900	5200	300	2
Arctic Russia	1700	1100	6300	1000	5



Table 4.3 shows transfer coefficients for  $^{137}\text{Cs}$  to reindeer. Initial comparison of the transfer coefficients for  $^{137}\text{Cs}$  to reindeer meat and lichen reveals that transfer to reindeer in arctic Finland and Russia is proportional to that for lichen but, transfer to reindeer is, relatively, lower in Greenland. This is probably because reindeer are slaughtered in Greenland during the summer, when activity concentrations in their meat will reflect their summer diet of green vegetation. A lower transfer coefficient to Greenland reindeer might, therefore, be

Table 4.3. Integrated transfer coefficients for  $^{137}\text{Cs}$  to arctic reindeer meat (Bq/kg y per Bq/m<sup>2</sup>).

Area	Integrated deposition (Bq/m <sup>2</sup> )	Time integrated concentration (Bq/kg y)			Integrated transfer coefficient
		1950-1959	1960-1994	1995-	
Arctic Finland	2500	5700	34000	5500	18
Greenland	4300	1500	6500	600	2
Arctic Norway	4400	4200	31000	9500	10
Arctic Russia	3100	4300	21000	3300	9

expected, compared with reindeer from Finland and Norway, where animals are slaughtered in winter.

In Russia, some reindeer are slaughtered all the year round, which could potentially lead, on average, to lower transfer. However, the raw data for Russian reindeer were collected from a range of areas, with inadequate frequency of sampling to establish a time series for different indigenous regions. The data were, therefore, too scattered, spatially and temporally, to explore the seasonal factors influencing the transfer coefficient.

This highlights a more general problem with representativeness of lichen and reindeer samples. As deposition of  $^{137}\text{Cs}$  from nuclear weapons tests was distributed fairly homogeneously, lichen samples collected locally at Inari in Finnish Lapland were representative of Finnish Lapland as a whole, *i.e.*, they were comparable with the reindeer samples. However, after Chernobyl, Inari received rather more (three times higher) fallout than most of the surrounding area. Hence after 1986, lichen from Inari would no longer be directly comparable to Finnish reindeer meat samples, which integrate deposition from a large area.

A further variable influencing the time integrated transfer coefficient is in the use of countermeasures. In many parts of Norway and Sweden that received deposition from Chernobyl, countermeasures were applied, including use of intra-ruminal boli and salt licks. This could explain why  $^{137}\text{Cs}$  transfer to reindeer meat appears lower in Norway than in Finland, where such countermeasures were not introduced.

#### 4.1.2 South Urals Contamination Studies (SUCON)

This is an EC supported project with Risø acting as coordinator and with participation from UK (NRPB), Norway (NRPA, IFE and AUN), Russia (IAPE) and Ukraine (IBSS).

A major effort in 1997 has been the analysis of river sediments and samples of floodplain soils from the Techa and Iset rivers *i.e.* the upper reaches of the Ob-

river system (see Figure 4.1 and Figure 4.2). The purpose has been to study the contamination of the river system with the waterborne discharges from MAYAK.

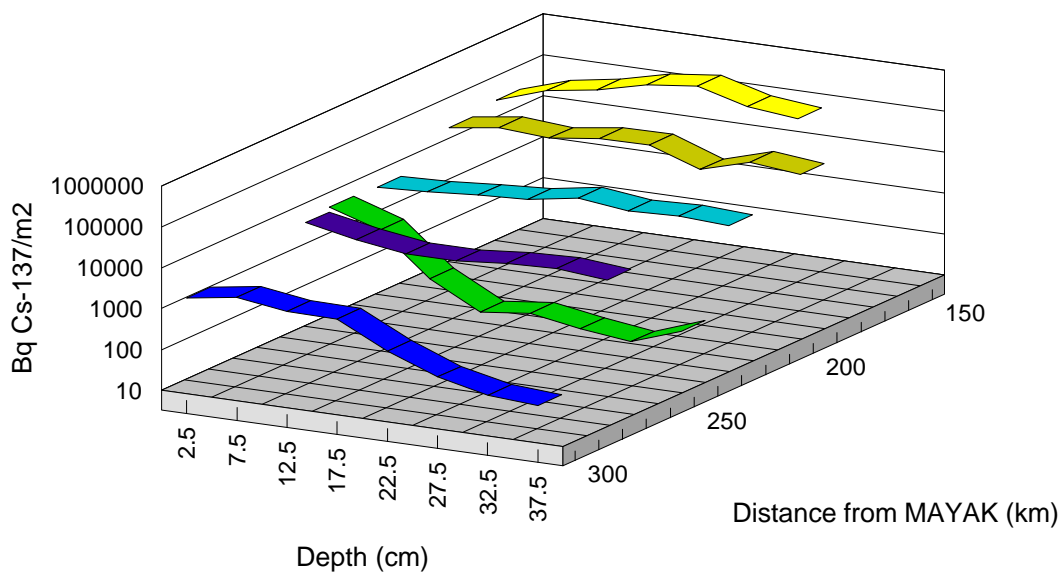

Figure 4.1. Spatial distribution of  $^{137}\text{Cs}$  in floodplain soils collected in 1996 from Techa and Iset rivers.

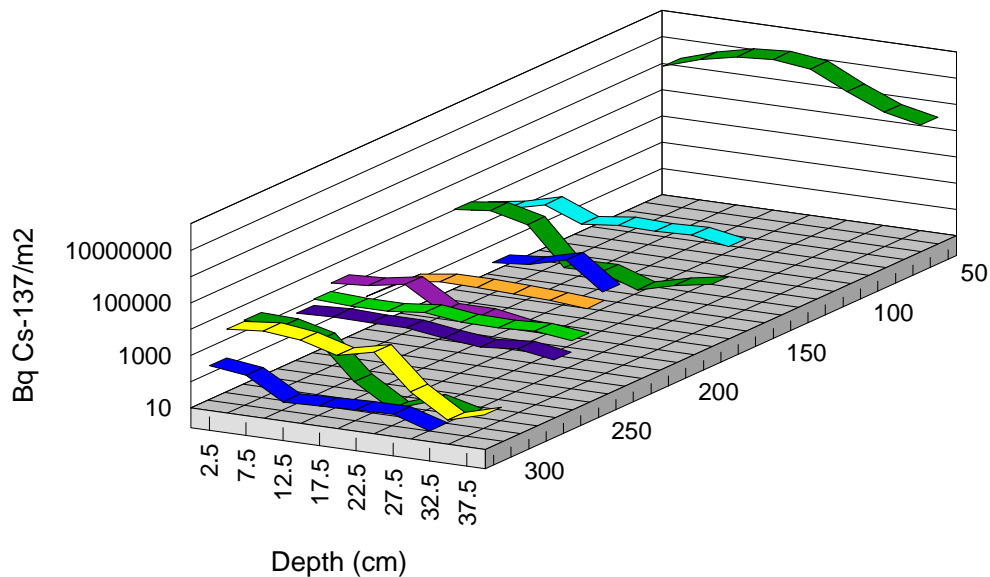

Figure 4.2. Spatial distribution of  $^{137}\text{Cs}$  in sediments from Techa and Iset rivers collected in 1996. (Nadirov in 1992)

### 4.1.3 Technetium-99 in a Techa River sediment column

Sediments collected from the Techa River at Nadirov Bridge were analysed for  $^{99}\text{Tc}$ . The maximum concentration was found at a depth of 14-18 cm. This layer was sedimented around 1950, i.e. at a time when the maximum releases of waterborne radionuclides occurred to the river from the Mayak. The vertical distribution of  $^{99}\text{Tc}$  in sediments followed that of  $^{137}\text{Cs}$  (see Figure 4.3) and the mean ratio between  $^{99}\text{Tc}$  and  $^{137}\text{Cs}$  in the sediments at the time of discharge was  $0.41 \times 10^{-3}$ . Laboratory experiments showed that  $^{99}\text{Tc}$  under anoxic conditions, e.g. when organic material is decomposing, will be retained by sediments.

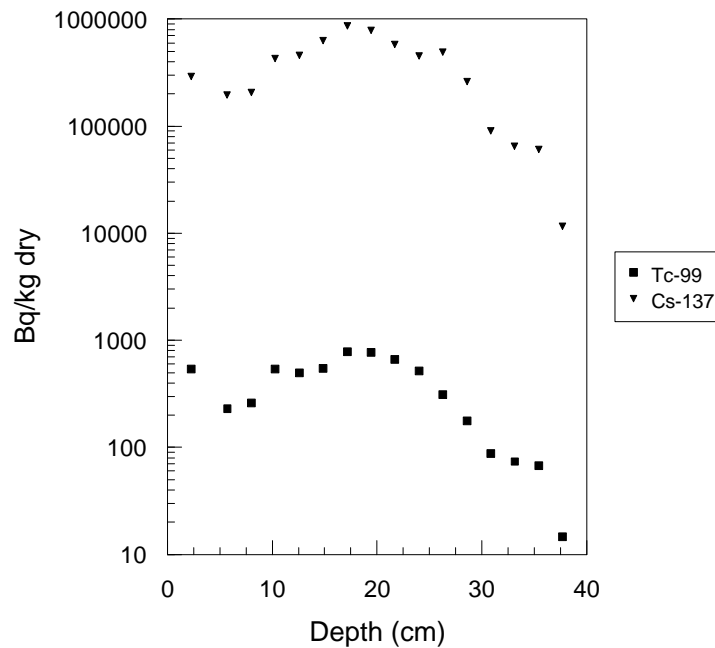

Figure 4.3. Depth distributions of  $^{99}\text{Tc}$  and  $^{137}\text{Cs}$  concentrations in Techa river sediments from Nadirov Bridge.

If the  $^{99}\text{Tc}$  to  $^{137}\text{Cs}$  ratio found in the sediments is representative for the ratio in the liquid discharges from MAYAK, i.e. if  $^{99}\text{Tc}$  and  $^{137}\text{Cs}$  under the given circumstances had the same  $K_d$  the discharge of  $^{99}\text{Tc}$  is calculated to  $0.41 \cdot 10^2 \cdot 12.2 \text{ PBq} = 5 \text{ TBq } ^{99}\text{Tc}$ . However, this figure is probably a minimum estimate of the  $^{99}\text{Tc}$  discharge as it seems unlikely that all  $^{99}\text{Tc}$  should have been retained just as readily by the sediments as  $^{137}\text{Cs}$ . If the ratio in the discharge had been the same as in the discharges from Sellafield i.e.  $2.1 \cdot 10^{-2} \cdot 12.2 \text{ PBq} = 0.3 \text{ PBq } ^{99}\text{Tc}$  had been discharged and most of this would then have reached the Arctic Ocean through the Ob river system. If such an input of  $^{99}\text{Tc}$  had occurred to the Arctic Ocean around 1950 it should be possible to see a signal in brown algae (e.g. *Furoids*) which concentrate Tc from seawater by a factor of  $10^5$  if any seaweed, e.g. in herbarium, have been preserved from that time.

#### 4.1.4 Isotopes of Neptunium, Uranium and Plutonium in environmental samples from Urals

In a joint American-Russian-Danish study Np, U and Pu were analysed by mass spectroscopy (M.S.) on samples contaminated by Mayak debris.

Table 4.4 shows a number of atom ratios for an Ural soil sample contaminated with Kyshtym accident (1957) debris.

Table 4.4. Mass spectrometric determinations of actinide element isotopes in soil (0-5) contaminated by the 1957 accident at Mayak, Chelyabinsk Province (7.5 km SE of 56 °N, 61 °E at Musakaevo). Atom Ratio  $\pm 1\text{S}$  uncertainty

	$^{236}\text{U}/^{239}\text{Pu}$ ( $10^0$ )	$^{237}\text{Np}/^{239}\text{Pu}$ ( $10^0$ )	$^{240}\text{Pu}/^{239}\text{Pu}$ ( $10^0$ )	$^{241}\text{Pu}/^{239}\text{Pu}^{\text{II}}$ ( $10^{-3}$ )	$^{242}\text{Pu}/^{239}\text{Pu}$ ( $10^{-4}$ )
Aliquot # 1	0.312 $\pm$ 0.009	0.0717 $\pm$ 0.0025	0.0283 $\pm$ 0.0001	0.226 $\pm$ 0.008	0.798 $\pm$ 0.034
Aliquot # 2	0.311 $\pm$ 0.009	0.0737 $\pm$ 0.0033	0.0281 $\pm$ 0.0001	0.235 $\pm$ 0.005	0.632 $\pm$ 0.019

The low  $^{240}\text{Pu}/^{239}\text{Pu}$  atom ratio (= 0.106 for activity ratio) suggests weapons grade Pu.

The concentration of  $^{237}\text{Np}$  in soil sample was measured to 121 $\pm$ 4  $\mu\text{Bq/g}$  (US M.S.), 135 $\pm$ 2  $\mu\text{Bq/g}$  (M.S.) and 129 $\pm$ 7  $\mu\text{Bq/g}$  ( $\alpha$ -spectrometry). The agreement between mass spectroscopy (MS) and radiochemical determination of  $^{237}\text{Np}$  was satisfactory.

Furthermore sediments from Nadirov Bridge were analysed for  $^{237}\text{Np}$ . Alpha spectrometry gave 0.75 $\pm$ 0.03  $\mu\text{Bq/g}$  and M.S. 0.61 $\pm$ 0.01  $\mu\text{Bq/g}$ . The  $^{237}\text{Np}/^{239,240}\text{Pu}$  activity ratio became 0.00056 $\pm$ 0.00028 (mean of all determinations). The soil sample above showed a  $^{237}\text{Np}/^{239,240}\text{Pu}$  activity ratio = 0.00083 $\pm$ 0.00015 (mean of US and Risø determinations). A number of floodplain and sediment samples from Techa and Iset rivers were analysed by mass spectrometry for  $^{239}\text{Pu}$  and  $^{240}\text{Pu}$ , the  $^{240}\text{Pu}/^{239}\text{Pu}$  atom ratio in these samples collected between 169 and 297 km from the original discharge point at Mayak varied between 0.016 and 0.039. The mean was 0.027 $\pm$ 0.0096 i.e. compatible with that of the soil sample in Table 4.4.

In other words most of the Pu found in and along the Techa-Iset rivers out to a distance of about 300 km from Mayak is due to the early releases around 1950.

## 4.2 Marine tracers

### Thule-1997 sampling expedition

In January 1968, a B52 plane carrying 4 nuclear weapons caught fire and crashed on the sea ice in Bylot Sound off Thule Air Base, north-west Greenland. From earlier samplings (1968, 1970, 1974, 1979, 1984, 1991) it has been estimated, that the pollution amounts to approximately 1 TBq  $^{239,240}\text{Pu}$  (0.5 kg), 0.02 TBq  $^{238}\text{Pu}$ , 4 TBq  $^{241}\text{Pu}$  and 0.05 TBq  $^{241}\text{Am}$ .

A new sampling expedition to the Thule accident site and to other locations on the coast was accomplished in August - September 1997 onboard the Greenland Homerule Fisheries investigation vessel "Adolf Jensen", Figure 4.4.

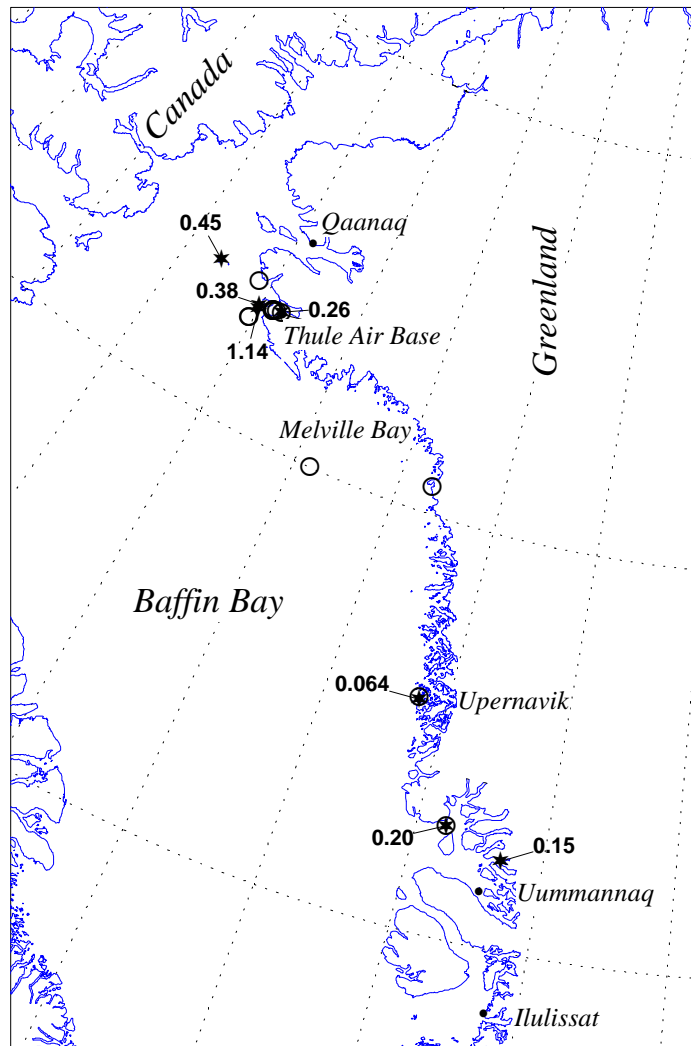

Figure 4.4. Thule 1997. Sampling locations for seawater (○) and seaweed(★). Concentration of  $^{239,240}\text{Pu}$  in *Fucus* is given as  $\text{Bq kg}^{-1}$  dry.

The aim of the new sampling was to reevaluate the remaining plutonium inventory in the marine environment, the biological availability in the benthos and the mobility of plutonium in the environment. The sampling expedition was performed as an international collaboration led by Risø and with indispensable contributions from Lund University, Sweden, Finnish Center for Radiation and Nuclear Safety, Finland, Radiation Protection Institute of Ireland and University College of Dublin, Ireland.

Preliminary results show:

- due to a relatively fast sedimentation rate, 3 - 4 mm/year, the 1968 contamination now peaks around 10 - 15 cm depth ,
- an extensive biological mixing of the upper sediment layers (bioturbation) maintains a relatively high surface contamination and extends the distribution down to more than 25 cm depth at some locations.
- hot particles are still present after 29 years: high anomalies signifying hot particles have been identified not only in the 10-15 cm peak layer, but also in the upper biota-reworked sediment layer.

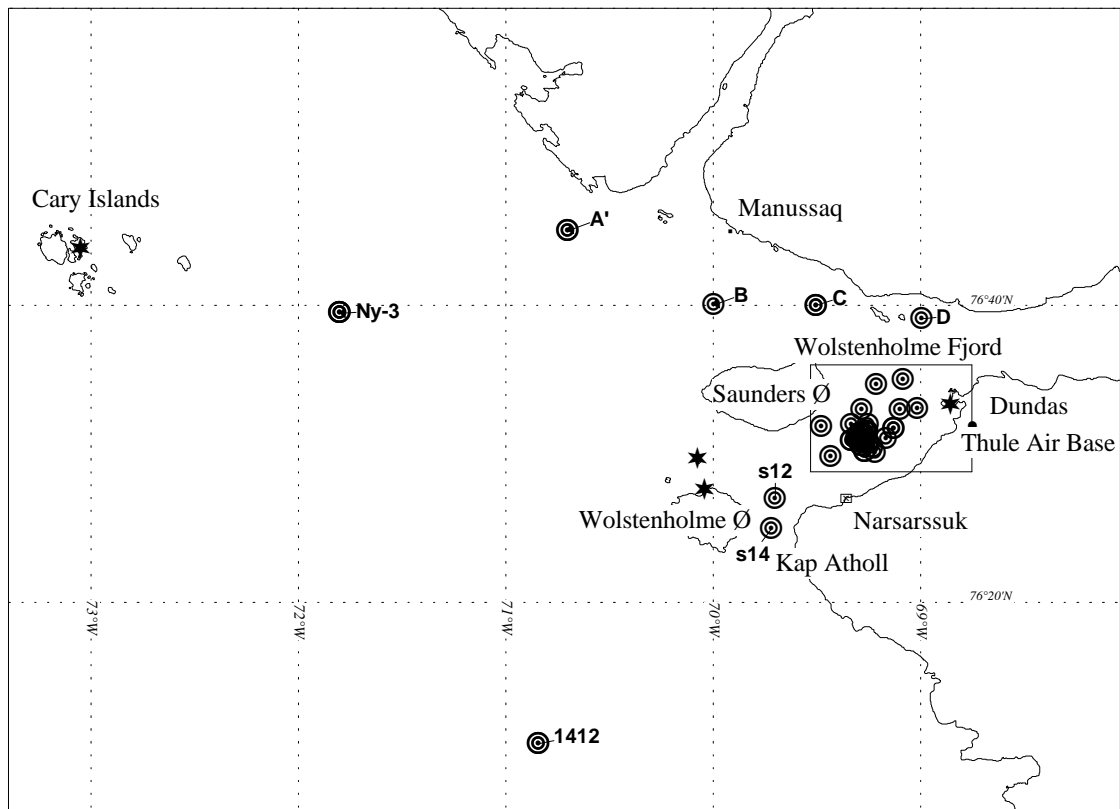

Figure 4.5. Thule-97. Sampling locations for sediments (©) and seaweeds (★). The framed area is enlarged in Figure 4.6.

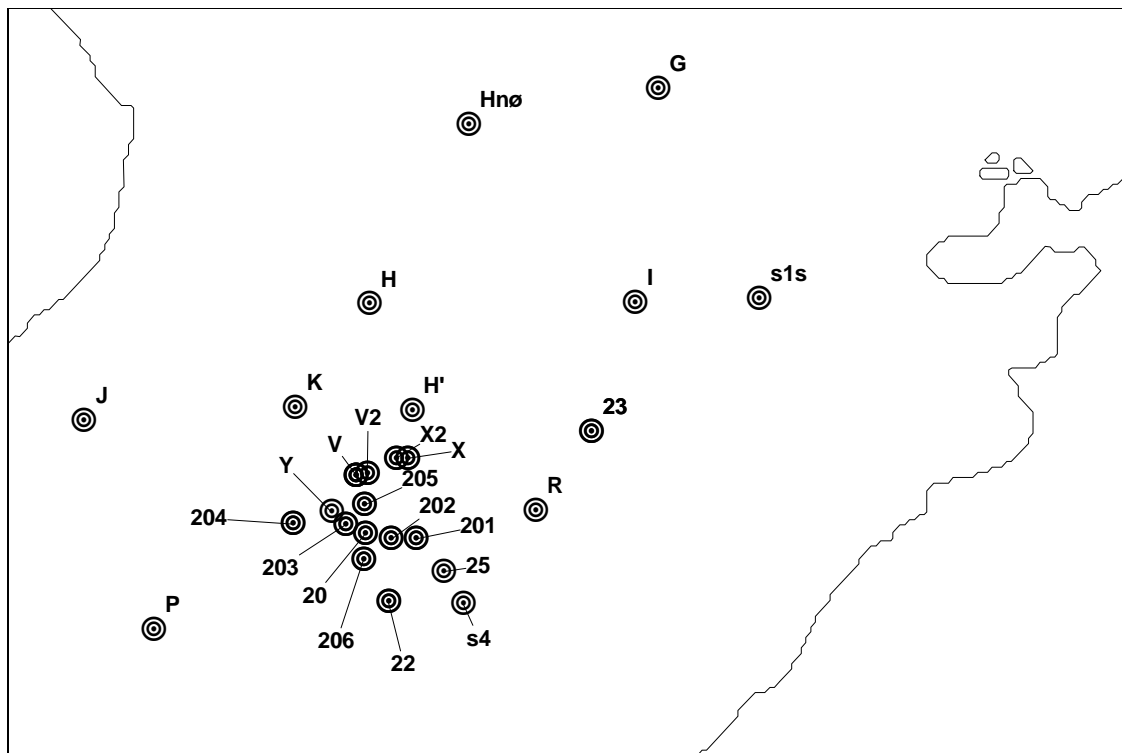
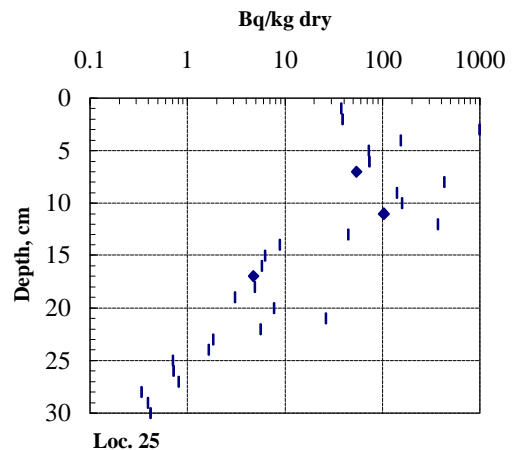
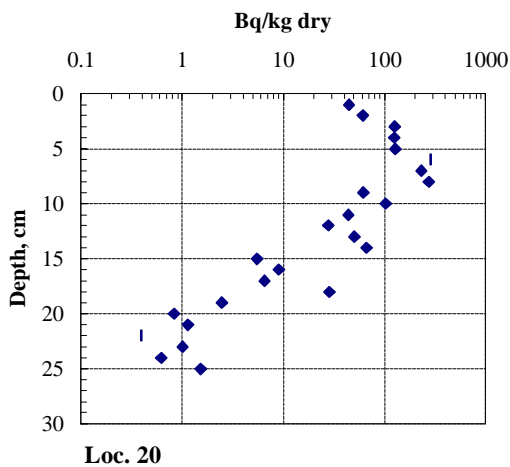
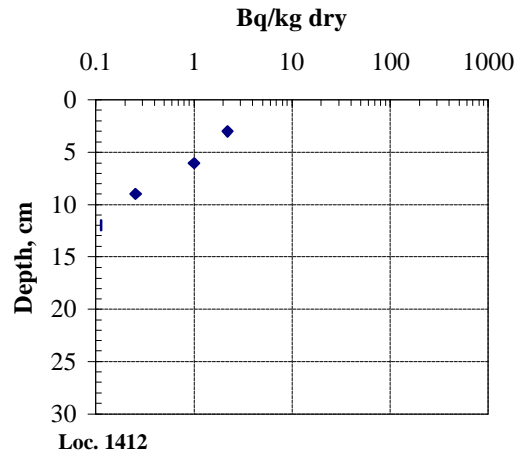
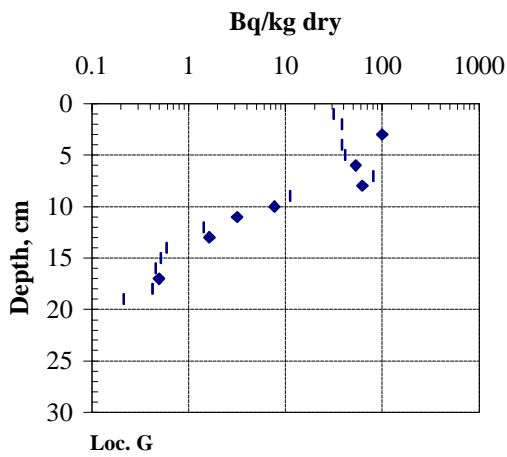

Figure 4.6. Thule-97. Sampling locations for sediments(©). The point of impact for the 1968 accident was at location V.

The following figures show plutonium results from 4 of the sediment cores representing different contamination patterns. Location 1412 is outside the contaminated zone.

Note the irregular pattern caused mainly by hot particles, e.g. at location 25.



## 4.3 Radioecological models

### 4.3.1 Radiological assessments of radioactivity in the marine environment

#### Dumped nuclear waste in the Kara Sea

An assessment commissioned by the European Commission was carried out to evaluate the radiological consequences of the marine reactors that were dumped in the Kara Sea by the former Soviet Union. Radionuclide inventories of fission products, actinides and corrosion products were calculated and release rates to the marine environment estimated based on rates of corrosion in seawater of steels, nuclear fuel and other materials. Table 4.5 gives an overview of the time-integrated releases from the waste sites for the best-estimate scenario.

Table 4.5. Time-integrated release of radionuclides to the Kara Sea.

Nuclide	Release (TBq)
Pu-238	1.1E-03
Pu-239	8.3E+00
Pu-240	2.3E+00
Pu-241	1.1E-11
Am-241	1.3E+00
Sr-90	3.8E-05
Cs-137	6.6E-04
Sm-151	1.0E-02
Tc-99	1.1E-01
I-129	3.8E-04
Fe-55	2.5E+01
Co-60	3.5E-01
Ni-59	4.9E+00
Ni-63	4.7E+00

The box model for Arctic waters developed by Risø was used for the calculation of doses to man from these source terms. For the collective dose truncated at 10000 years to the world population, a total dose of about 1 manSv was obtained. The dose rate to individuals from a critical group located in the western Kara Sea is shown in Figure 4.7. The break down of the maximum dose rates in year 1970 and 3700 by nuclide and exposure pathway are shown in Figure 4.8 and Figure 4.9 which show the percentage contributions to the maximum dose rates.

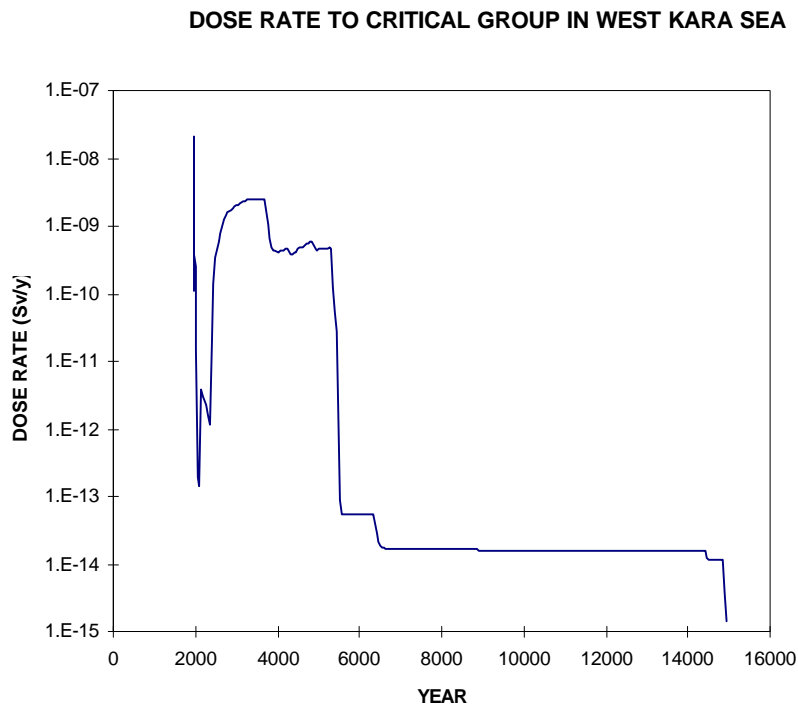

Figure 4.7. Annual dose rate ( $\text{Sv y}^{-1}$ ) to the critical group on the Yamal peninsula in the West Kara Sea.



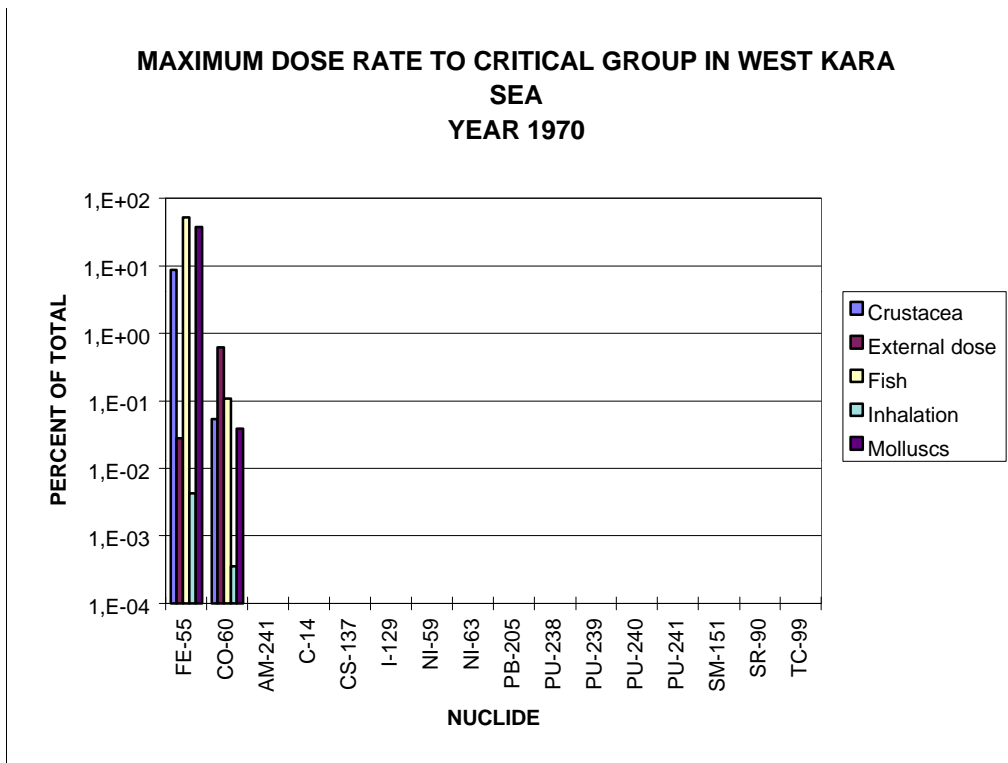

Figure 4.8. Relative contributions (per cent) by nuclide and exposure pathway to the peak annual dose in year 1970 to the critical group on the Yamal peninsula.

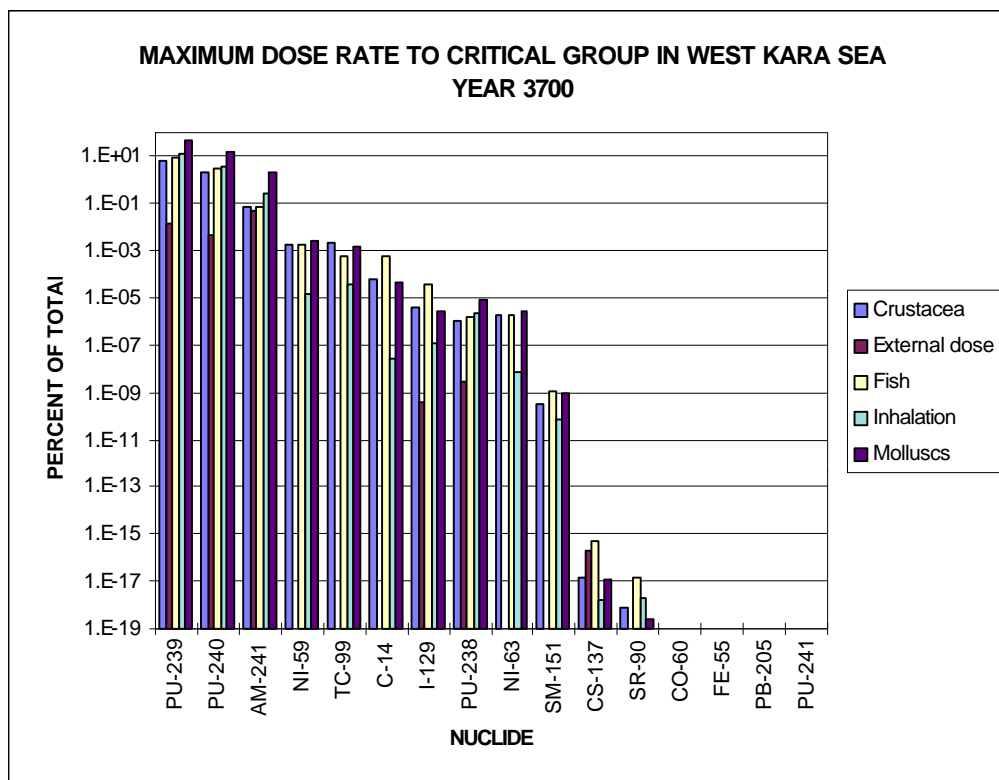

Figure 4.9. Relative contributions (per cent) by nuclide and exposure pathway to the peak annual dose in year 3700 to the critical group on the Yamal peninsula.

The maximum annual dose occurs in year 1970 at a value of  $2\text{E-}8 \text{ Sv y}^{-1}$  with contributions from Fe-55 and Co-60 at 99.2% and 0.8%, respectively. Figure 4.8 shows that the dominating exposure pathways are ingestion of fish for Fe-55 and external exposure for Co-60. The overall pathway contributions to the maximum annual dose are ingestion of fish 52%, ingestion of molluscs 38%, ingestion of crustaceans 9%, external exposure 0.7% and inhalation 0.005%. The peak annual dose in year 3700 has a value of  $2\text{E-}9 \text{ Sv/y}$  and is dominated by the Pu-isotopes as shown in Figure 4.9. The pathway contributions to the latter peak annual dose are ingestion of molluscs 64%, inhalation 16%, ingestion of fish 11%, ingestion of crustaceans 9%, and external exposure 0.07%.

### **The Komsomolets submarine**

An assessment was made with the Arctic model of the potential radiological consequences from the release of Pu-239 from the submarine Komsomolets which suffered an accident in the Norwegian Sea in 1989 and sank about 200 km south-west of Bear Island at a depth of 1600 m.

The source term of radioactivity was assumed to comprise 8 kg of Pu-239 of which the 6 kg originates from the nuclear warheads and the rest from the nuclear reactor. The specific activity of Pu-239 is 2.3 TBq per kg, so the source term is assumed at a rounded number of 20 TBq. The rate of release has been assumed to be rather fast (one year) based on information from Russian sources concerning accelerated galvanic corrosion due to the titanium hull of the submarine. The source was assumed situated in a small local box (of  $1 \text{ km}^3$  volume) on the seabed connected to the deep waters of the Norwegian Sea.

The dispersion of plutonium has been simulated with the box model covering the Arctic Ocean and the North Atlantic providing the basis for calculating the transfer of plutonium to marine biota. Global fisheries statistics have been used to estimate the transfer of plutonium to man and the corresponding collective dose to the world population. The calculation of the dose was truncated at 1000 y. The total collective dose from ingestion of seafood was estimated at a value of 8 manSv.

### **Model testing**

The reliability of the predictions made from box models has been tested for the Baltic Sea covering a comparison between calculated and observed annual mean concentrations of the radionuclides Cs-137 and Sr-90 for the time period 1970-1991. The sources of radioactivity considered include fallout from nuclear weapons testing, fallout from the Chernobyl accident, discharges to sea from Sellafield and La Hague and discharges to sea from nuclear facilities bordering the Baltic Sea.

The comparison is illustrated in Figure 4.10 showing a scatterplot between observed and predicted annual average concentrations of Cs-137 in seawater. The full line gives the ideal 1:1 relationship. The geometric mean of the predicted-to-observed (P/O) ratio is 1.1 with a geometric standard deviation of 1.4. Figure 4.11 shows a scatterplot of the observed and predicted annual average levels of Sr-90 in seawater. The geometric mean of the P/O values is 0.8 with a geometric standard deviation of 1.4.

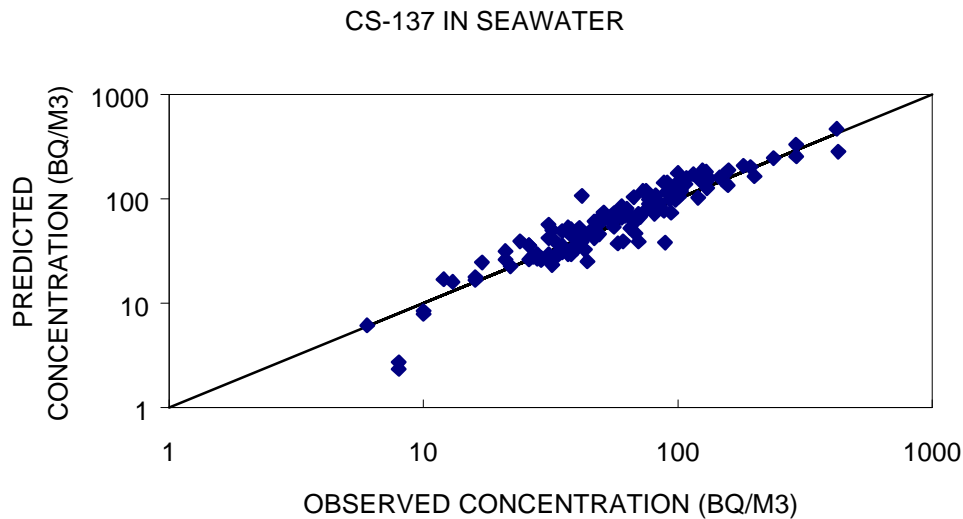

Figure 4.10. Scatterplot of predicted and observed annual mean concentrations of Cs-137 in Baltic seawater. The line indicates the 1:1 relationship.

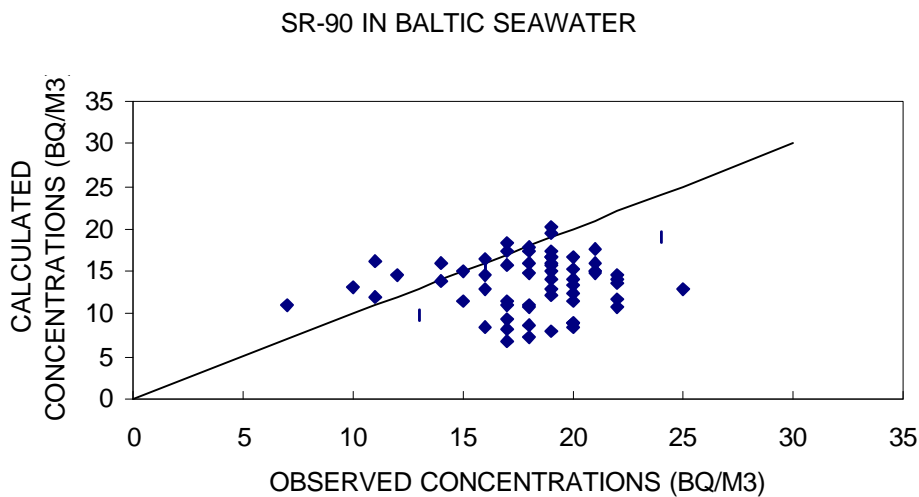

Figure 4.11. Scatterplot of predicted and observed annual mean concentrations of Sr-90 in Baltic seawater. The line indicates the 1:1 relationship.

### Sensitivity analysis

A sensitivity analysis was carried out to identify components of the Arctic model that are potentially important contributors to the predictive accuracy. The components investigated include features associated with water transport and mixing, particle scavenging, water-sediment interaction and biological uptake. The source terms used for the calculations were obtained from the IAEA's International Arctic Seas Assessment Project (IASAP). The best-estimate release scenario was selected comprising release rates of radionuclides from shallow bays on the East Coast of Novaya Zemlya (Abrosimov Bay and Tsvolki Bay) and from the deeper waters of the Novaya Zemlya Trough. The

radionuclide-specific releases considered are shown in Table 4.6, and Figure 4.12 shows the release rate assumed for the Tsivolki Bay where the reactor compartment and spent nuclear fuel from the Lenin icebreaker was dumped in 1967. The graph shows that the best-estimate scenario assumes release of the activation products only (Co-60, Ni-59, Ni-63) until the year 2300 due to corrosion of the protective barriers. At that time contact is assumed between the seawater and the spent nuclear fuel, and a peaked release of fission products (Cs-137 and Sr-90) and transuranics (Pu-239, Pu-240, Am-241) is assumed followed by a steady release due to corrosion of the nuclear fuel.

Table 4.6. Integrated release of radionuclides (TBq) dumped in the Kara Sea, IASAP best-estimate scenario.

	Tsivolki Bay	Abrosimov Bay	Novaya Zemlya Trough
Pu-239	4.9	0.73	0.09
Pu-240	2.1	0.32	0.04
Am-241	0.41	0.12	0.01
Co-60	0.03	2.9	0.08
Ni-63	370	110	1.9
Ni-59	40	110	2.3
Cs-137	0.10	41	8.7
Sr-90	0.07	34	7.4

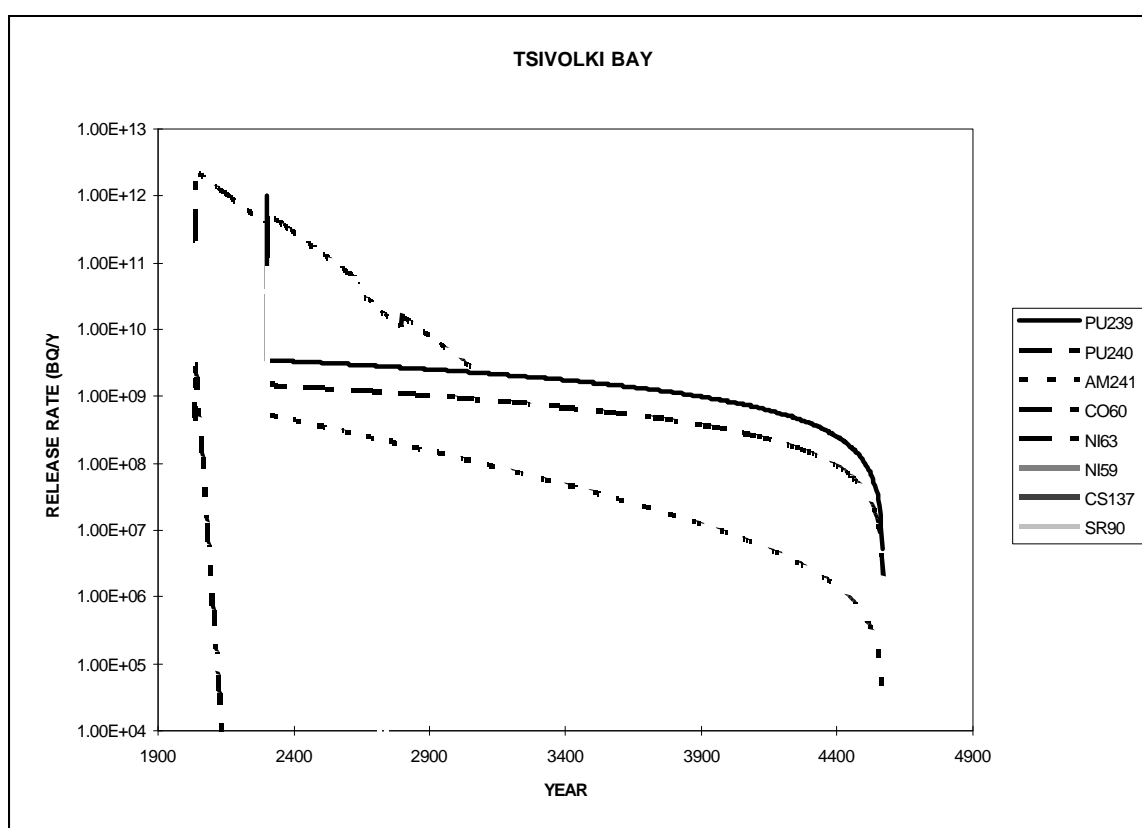

Figure 4.12. Radionuclide release rates ( $Bq\ y^{-1}$ ) for Tsivolki Bay estimated by the IASAP Source Term Group.

The parameter sensitivity of the doses to individuals and populations has been investigated concerning three main processes: water movement and mixing, sediment-water interaction and biological transfer. For the hydrodynamical processes, four parameters were investigated: the advection and mixing between the Kara Sea and the Laptev Sea to the east, the advection and mixing between the Kara Sea and the Barents Sea to the west, the vertical mixing between surface and deeper waters over the Novaya Zemlya Trough, and the rates of exchange of water between the bays containing the dumped waste and the open Kara Sea. The sediment-related parameters were the following: sedimentation rates, sediment distribution coefficients ( $K_d$ ), suspended sediment loads, depth of the mixed surface sediment layer, and the mixing rates in the surface sediments. For the biological transfer processes, the three parameters representing biological concentration factors for fish, crustaceans and molluscs were included.

The parameter sensitivity analysis was carried out by assigning identical variabilities of 10% to all the above mentioned parameters and running the model repeatedly (about 500 times). Correlation coefficients were calculated between parameter values and dose values, and the square of the correlation coefficients ( $R^2$ ) were interpreted as how much of the variation of the doses is explained by the linear relationship to the parameters. The parameter sensitivities are thus expressed in percent of the total variability.

The results of the parameter sensitivity analysis for the collective doses are shown in Table 4.7 which summarises the integrated releases, the collective doses and the main parameter sensitivities ( $> 1\%$ ). The total collective dose is calculated to 0.4 manSv (truncated at 1000 y) with dominating contributions from plutonium isotopes of 57% and from Cs-137 of 37%. The parameter sensitivities are seen to vary across the radionuclides from Sr-90 which has a low  $K_d$  to the transuranics and activation products which have high  $K_d$ 's. For the total collective dose the main parameter sensitivities are due to sedimentation processes (sedimentation rate,  $K_d$ , suspended sediment load) and biological transfer processes (concentration factor for fish).

Table 4.7. Integrated releases (TBq), collective doses (manSv) and main parameter sensitivities (%).

Nuclide	Cs-137	Sr-90	Pu-239	Pu-240	Co-60	Am-241	Ni-63	Ni-59	Total
Total release (TBq)	49	42	6	2.4	3	0.5	480	150	
Coll. Dose (manSv)	0.14	0.02	0.16	0.06	7E-05	0.001	0.002	0.001	0.4
Coll. Dose (%)	37	5	41	16	0.02	0.4	0.6	0.3	100
Sedimentation rate, (%)	19		66	66	54	61	53	53	45
Conc. Factor, fish (%)	65	90			13		4	4	28
$K_d$ (%)	11		13	13	25	7	24	24	12
Susp. Sediment load, (%)			16	16	4	14	1	1	9
Conc. Factor, molluscs (%)			9	9		5	1	1	5
Adv., Kara Sea, west (%)	4	1					4	4	2

### Parameter uncertainty analysis

Variabilities were assigned to the most sensitive parameters identified above. The variabilities take into account current observed variability and estimated future variability. The variabilities are expressed as ranges around the central values (c), so that for each parameter the same factor (f) determines the high value (c·f) and the low value (c/f). The factors of variability for the sediment

related parameters were 2 for the sedimentation rate, 2 for the suspended sediment load and 10 for the sediment distribution coefficient,  $K_d$ . A factor of 3 was used for the variability of each of the three biological concentration factors for fish, crustaceans and molluscs. A factor of 2 was used for the variability of the rate of exchange of the water between the Novaya Zemlya bays and the Kara Sea. Finally, a factor of 2 was used for variability of the depth of the surface sediment layer in the Novaya Zemlya bays. There was no specific information available on suitable probability distributions for the different parameter values for which reason it was decided to sample (Monte Carlo technique) the values from log-uniform distributions with upper and lower values as specified above. The factors of variability were applied globally for each parameter across the model for each simulation. One hundred simulations were carried out for each model endpoint involving collective doses and doses to critical groups from the dominating nuclides (Fe-55, Co-60, Cs-137 and Pu-239) and source locations (bay and Novaya Zemlya depression) to determine the ranges on the model output values. This number of simulations was considered adequate for the purpose as confirmed from carrying out 500 simulations for one of the above combinations.

### Uncertainties of maximum annual doses to critical groups

The results of the parameter uncertainty calculations on the peak annual doses to the critical groups are shown in graphical form in Figure 4.13.

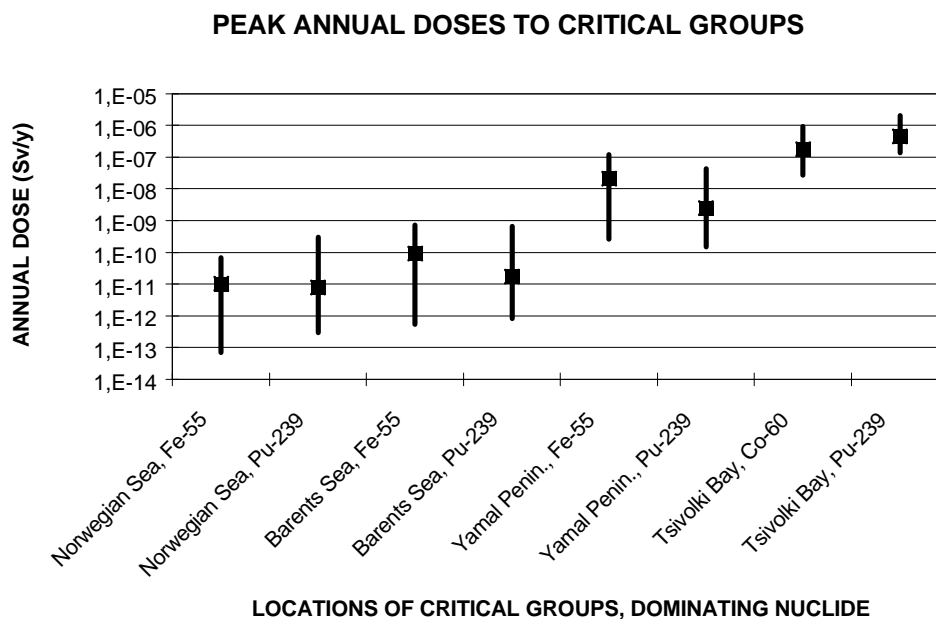

Figure 4.13. Peak annual doses to critical groups ( $Sv\ y^{-1}$ ) with ranges of variability estimated from parameter uncertainty analysis.

Correlation analysis has been carried out using rank correlation coefficients to identify and quantify the main components of variability. Only correlation coefficients numerically greater than 0.5 are mentioned. The peak annual doses to the critical groups show negative correlation coefficients with the sediment distribution coefficients,  $K_d$ 's, of -0.8 for Fe-55 and -0.6 for Pu-239 while the

sedimentation rates and the peak annual doses give negative correlation coefficients of -0.5 for both radionuclides. This means that high doses are associated with low values of the two parameters. Both radionuclides have high  $K_d$  values and are therefore particularly sensitive to sedimentation processes that transfer the radionuclides from the water column to the sediments and reduce the wider dispersion of the nuclides in the marine environment. For the critical group located in Tsivolki Bay on Novaya Zemlya, the analysis shows other results due to the different exposure pathways that apply here. The peak annual dose from Co-60 shows a negative correlation coefficient of -0.8 with the depth of the surface sediment layer (mixing layer). This is due to the dominating exposure pathway, which in this case is external exposure from Co-60 in coastal sediments in which the concentration is inversely related to the depth of the mixing layer. The peak annual dose from Pu-239 shows a negative correlation coefficient of -0.7 with the bay flushing rate. In this case inhalation is the dominating exposure pathway, which is controlled by the concentration of Pu-239 in the water of the bay, and the peak concentration is inversely related to the bay-flushing rate.

The predicted variabilities of the peak annual doses to the critical groups around the mean values increase with distance from the Kara Sea. For the doses dominated by long-lived plutonium isotopes, the variability is nearly symmetrical around the mean value on a log-scale corresponding to the factors of variability applied to the parameters. The predicted variabilities on the doses from Pu-isotopes range from a factor of about 4 in Tsivolki Bay to a factor of about 40 in Norway. For the doses dominated by the short-lived Fe-55, the variability is non-symmetrical around the mean value on a log-scale due to the low values being associated with delayed transfer involving further physical decay. The variabilities for Fe-55 of the maximum values relative to the mean values range from a factor of 6 in the Kara Sea to a factor of 10 in Norway. The variabilities of the minimum values relative to the mean values range from a factor of about 80 in the Kara Sea to a factor of about 250 in Norway.

### **Uncertainties of collective doses**

The predicted variability of the collective dose to the world population is based on the variability predicted from the plutonium isotopes. Correlation analysis shows that the collective dose is negatively correlated with the sediment related parameters yielding a correlation coefficient of -0.7 for the sediment distribution coefficient and a correlation coefficient of -0.5 for the sedimentation rate.

The predicted variability of the collective dose is about two orders of magnitude up and down around the mean value of about one man sievert. The collective dose is thus predicted at a level of about one man sievert and not to exceed one hundred man sieverts.

## **4.4 Contamination physics**

### **4.4.1 Radiation doses received from contamination of skin and clothing**

An estimation was made of the relative contribution to dose from skin contamination in a dry deposition scenario following an airborne release of radioactive matter. To facilitate a comparison with the doses received from radioactive matter deposited on other surfaces in the environment after an accidental release, the skin-related doses were calculated on the basis of near-surface air concentrations of different contaminants measured after the Chernobyl accident, published by Kryshev (1996) in Radiation Protection

Dosimetry. These concentrations were derived from measurements made in the Novozybkov area of Russia over the first two months after the release. The time-integrated air-concentrations of measurable particles are shown in *Table 4.8*.

This reference does not distinguish between the different chemical forms of iodine. However, the COSYMA model suggests that 99% of the iodine is in the elemental form (with a dry deposition velocity of 0.01 m/s), while the remaining 1% is in organic form (deposition velocity:  $5 \cdot 10^{-4}$  m/s).

It should be considered that the concentration of aerosol in the Novozybkov area was greatly depleted by rain, which lead to high ground contamination levels. However, it followed from the air concentrations and from measured deposition velocities to a lawn that the contribution to the ground contamination level from *dry* deposition of  $^{137}\text{Cs}$  in the area (the nuclide which essentially determines the long-term doses from the ground) was only about 8 kBq/m<sup>2</sup>.

With the exception of iodine, for which the chemistry is more complex, the different contaminant aerosol was divided into two groups : the volatile ( $^{132}\text{Te}$ ,  $^{134}\text{Cs}$ ,  $^{137}\text{Cs}$ ,  $^{99}\text{Mo}$ ,  $^{103}\text{Ru}$  and  $^{106}\text{Ru}$ ) with lower AMAD values in the order of 0.7  $\mu\text{m}$  and the refractory group with higher AMAD values in the order of 4  $\mu\text{m}$ , to which  $^{140}\text{Ba}$ ,  $^{95}\text{Zr}$ ,  $^{141}\text{Ce}$ ,  $^{144}\text{Ce}$ ,  $^{89}\text{Sr}$  and  $^{90}\text{Sr}$  belong.

As indicated above, the dry deposition velocities of the different contaminant aerosol to a grassed lawn were estimated from field measurements made shortly after the Chernobyl accident and from COSYMA parameters. The estimates of dry deposition velocities to skin were based on the results obtained in the current project.

It was assumed in the calculations that the people in the area stayed indoor during virtually the entire deposition phase.

The relationship between the indoor and outdoor air concentrations was found from the following expression:

$$C_i / C_o = f \lambda_r / (\lambda_r + \lambda_d)$$

where  $\lambda_r$  is the fraction of air exchanged per unit of time,  $\lambda_d$  is the fraction of aerosols indoors depositing per unit of time and  $f$  is the filtering factor (the fraction of aerosols in air entering the building which is not retained in cracks and fissures of the building structure).

Numerous experiments carried out under the current project have shown that the filtering factor can be assumed to be 1 and that a realistic value of  $\lambda_r$  is 0.4 h<sup>-1</sup>. Further, it was estimated from the experimental data that  $\lambda_d$  would be in the order of 3 h<sup>-1</sup> for aerosols of the refractory group and 0.4 h<sup>-1</sup> for most of the volatiles, with the exception of the rutheniums, for which  $\lambda_d$  was estimated to be 1.1 h<sup>-1</sup> and of the iodine, for which the  $\lambda_d$  estimate was based on publications of Kocher and Roed & Cannell . The corresponding  $C_i / C_o$  relationships can be seen in *Table 4.8*. The total integrated skin deposition (kBq/m<sup>2</sup>) was calculated by multiplication of the time-integrated air concentrations by the indoor/outdoor relationship and the skin deposition velocities. These values are also listed in *Table 4.8*.

A 'half-life correction' was then introduced, taking into account both the radioactive decay half-lives of the isotopes and a 'clearance' half life, by which the skin contaminant concentration is depleted. The COSYMA modellers assume the latter to generally be in the order of 30 days, and this value was used in the calculations.

For estimation of the dose contribution to the body from gamma emission on skin, Monte Carlo calculations were performed using the MCNP code. A simplified model was applied, in which a tissue equivalent ICRP sphere was irradiated by a surface contamination. It was found that the sensitivity of this



model towards changes in sphere diameter was small. In the model the sphere was placed at a height of 1m above ground. Figure 4.14 shows the energy dependence of the gamma doses received per gamma ray emitted each second from an area of 1 cm<sup>2</sup>. The relative uncertainty of the Monte Carlo calculations was in all cases less than 1%.

Table 4.8. Parameters applied in the calculations of doses received from gamma emission from skin contamination. Values relating to published air concentrations of different isotopes measured in near-ground level air in Novozybkov. Integrated air concentrations are given together with radioactive half-lives, AMADs, indoor/outdoor air concentrations, deposition velocities to skin and grassed lawn, half-life correction factor (over 1 year), doses per Bq/cm<sup>2</sup> (by Monte Carlo) and total doses received by this pathway.

Isotope	Integr. air contam. Bq*s/m3 (Kryshev)	T <sub>1/2</sub> (days)	AMAD μm	Ci/Co	Vd, face/hand m/s	Vd,grass, m/s	Contam Bq/m <sup>2</sup> skin	Half-life correct.	Dose,Sv total per Bq/cm <sup>2</sup>	Dose,Sv total
I-131 (organic)	1.79E+06	8	0.5	0.36	5.00E-03	5.00E-04	3222	0.0249	6.80E-05	5.47E-07
Te-132	1.81E+07	3.25	0.7	0.5	1.00E-03	4.30E-04	9050	0.0115	3.50E-05	3.67E-07
Cs-134	8.93E+06	767	0.7	0.5	1.00E-03	4.30E-04	4465	0.1140	2.27E-04	1.16E-05
Cs-137	1.78E+07	10987	0.7	0.5	1.00E-03	4.30E-04	8900	0.1182	1.02E-04	1.07E-05
Ba-140	1.08E+07	12.8	4	0.12	1.20E-02	7.50E-04	15552	0.0354	2.35E-05	1.3E-06
Zr-95	2.67E+06	65.5	4	0.12	1.20E-02	7.50E-04	3845	0.0813	1.36E-04	4.25E-06
Mo-99	5.18E+06	2.75	0.7	0.5	1.00E-03	4.30E-04	2590	0.0099	2.66E-05	6.86E-08
Ru-103	9.10E+06	39.6	0.7	0.27	1.00E-03	4.10E-04	2457	0.0674	8.70E-05	1.44E-06
Ru-106	2.28E+06	369	0.7	0.27	1.00E-03	4.10E-04	616	0.1096	3.20E-05	2.16E-07
Ce-141	3.17E+06	32.5	4	0.12	1.20E-02	7.50E-04	4564	0.0616	1.10E-05	3.1E-07
Ce-144	2.14E+06	284.4	4	0.12	1.20E-02	7.50E-04	3081	0.1072	3.20E-06	1.06E-07
Sr-89	1.32E+05	50.5	4	0.12	1.20E-02	7.50E-04	190	0.0743	0	0
Sr-90	1.41E+04	10585	4	0.12	1.20E-02	7.50E-04	20	0.1182	0	0
Np-239	1.68E+07	2.4	4	0.12	1.20E-02	7.50E-04	24192	0.0087	1.20E-05	2.55E-07
I-131 (elem.)	1.77E+08	8		0.07	1.00E-02	1.00E-02	123900	0.0249	6.80E-05	2.1E-05

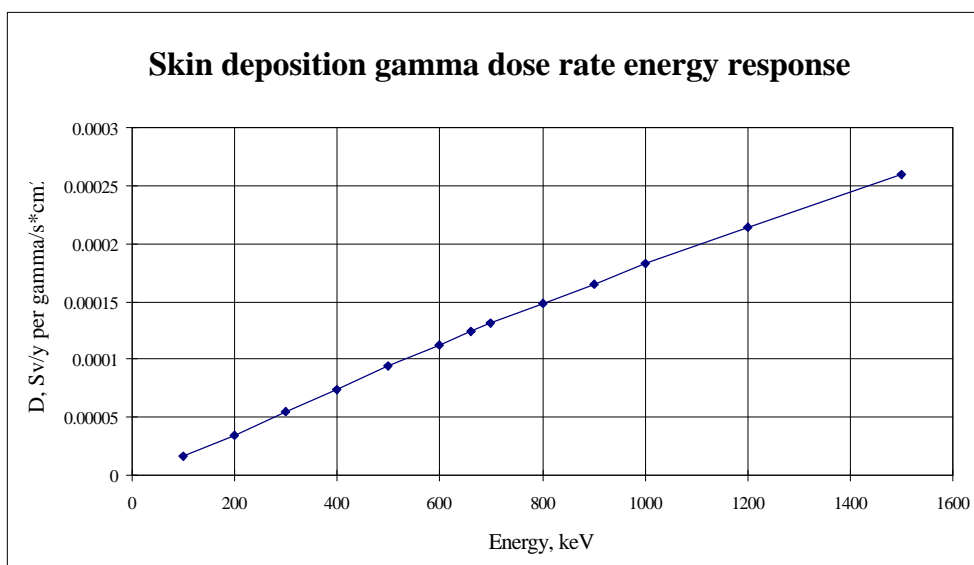

Figure 4.14. Monte Carlo modelled whole-body gamma doses received from skin contamination. Dose responses as a function of gamma ray energy.

Another dose contribution from contamination deposited on skin comes from beta radiation. The calculations of this contribution required a knowledge of the dose rate to the basal layer of the epidermis for the different isotopes. Nuclide-specific absorbed dose rates at an epidermis equivalent depth in water (ca. 70  $\mu\text{m}$ ) from various beta sources were derived from the figures stated in ICRU report 56 (1997). The ICRU figures were mostly based on the Monte Carlo calculations of Cross et al. The results are shown in Table 4.9. These dose rate factors were found to be in fairly good agreement with the corresponding factors reported by Faw (Health Physics, 63, 1992).

By multiplication of the skin contamination levels by the 'half-life correction factor' and the dose rate factors for beta exposure at a depth of 70  $\mu\text{m}$ , the total doses to the skin were found. Also presented in the Table are the doses weighted by a factor of  $0.01 * 0.15$ , corresponding to respectively the tissue weighting factor for skin (according to ICRP 60) and the fraction of the total skin constituted by the hands and the head (according to the report of the task group on reference man (ICRP 23). For simplicity, hair has not been considered in these calculations, which according to the deposition velocities recorded in the project together with the extra distance and shielding provided by the hair would make the estimates conservative. (Published in Radiation Protection Dosimetry in 1996)

The calculations of Rohloff and Heinzelmann clearly demonstrate that the dose rates received by photon radiation to the basal layer of the skin epidermis are negligible compared with the contributions from beta radiation.

*Table 4.9. Factors applied in the calculation of the beta doses to skin contaminated by indoor deposition of airborne radiopollutants with the air concentrations measured by Kryshev in the Novozybkov area following the Chernobyl accident.*

Isotope	Integr. air contam. Bq*s/m <sup>3</sup> (Kryshev)	T <sub>1/2</sub> (days)	AMAD $\mu\text{m}$	Ci/CO	Vd, face/hand m/s	Contam Bq/m <sup>2</sup> skin	Dose rate Sv/y per Bq/cm <sup>2</sup> at ca.70 $\mu\text{m}$ (ICRU56)	Half-life correct.	Dose, Sv total	Dose,Sv total tissue/% weighted
I-131 or	1.79E+06	8	0.5	0.36	5.00E-03	3222	0.012	0.0249	9.65E-05	1.45E-07
Te-132	1.81E+07	3.25	0.7	0.5	1.00E-03	9050	0.0079	0.0115	8.29E-05	1.24E-07
Cs-134	8.93E+06	767	0.7	0.5	1.00E-03	4465	0.0094	0.1140	0.000479	7.18E-07
Cs-137	1.78E+07	10987	0.7	0.5	1.00E-03	8900	0.014	0.1182	0.001473	2.21E-06
Ba-140	1.08E+07	12.8	4	0.12	1.20E-02	15552	0.013	0.0354	0.000717	1.08E-06
Zr-95	2.67E+06	65.5	4	0.12	1.20E-02	3845	0.01	0.0813	0.000313	4.69E-07
Mo-99	5.18E+06	2.75	0.7	0.5	1.00E-03	2590	0.013	0.0099	3.35E-05	5.03E-08
Ru-103	9.10E+06	39.6	0.7	0.27	1.00E-03	2457	0.0054	0.0674	8.95E-05	1.34E-07
Ru-106	2.28E+06	369	0.7	0.27	1.00E-03	616	0.016	0.1096	0.000108	1.62E-07
Ce-141	3.17E+06	32.5	4	0.12	1.20E-02	4564	0.014	0.0616	0.000394	5.91E-07
Ce-144	2.14E+06	284.4	4	0.12	1.20E-02	3081	0.0079	0.1072	0.000261	3.92E-07
Sr-89	1.32E+05	50.5	4	0.12	1.20E-02	190	0.015	0.0743	2.12E-05	3.18E-08
Sr-90	1.41E+04	10585	4	0.12	1.20E-02	20	0.013	0.1182	3.12E-06	4.68E-09
Np-239	1.68E+07	2.4	4	0.12	1.20E-02	24192	0.015	0.0087	0.000319	4.78E-07
I-131 el.	1.77E+08	8		0.07	1.00E-02	123900	0.012	0.0249	0.003712	5.57E-06

On the parts of the body that are covered by clothes, the beta skin doses are much lower due to the shielding effect of the clothing. The Tables in Appendix A of the ICRU 56 report show that due to the similar beta attenuation characteristics, it is reasonable to assume that equal mass-thickness of clothing

and tissue are equivalent in dose considerations. From the dose rate factors given in ICRU 56 it followed that practically no beta doses would be received through 3 mm thick clothing. The numbers presented in Table 4.10 express the doses that would be received through 0.4 mm thick clothing.

The dose rate factors found for 0.4 mm clothing were in reasonable agreement with those reported by Taylor et al. in Health Physics, 1997, for a 26 mg cm<sup>-2</sup> thick layer of cotton with a density of 0.7 g cm<sup>-3</sup>. Taylor et al. also demonstrated that an air gap of 1 cm between the skin and the clothing could halve the doses received from beta radiation with higher energies (above 0.4 MeV).

Also for the clothing, the clearance half-life recommended by the COSYMA modellers was applied. The deposition velocities to clothing were mainly evaluated from results of the current project. Also here, both the total doses to the skin epidermis and the weighted dose (by tissue weight factor and percentage of skin covered) are shown.

*Table 4.10. Factors applied in the calculation of the beta doses to skin, through contamination on clothing by indoor deposition of airborne radiopollutants with the air concentrations measured by Kryshev in the Novozybkov area following the Chernobyl accident.*

Isotope	Integr. air contam. Bq*s/m3 (Kryshev)	T <sub>1/2</sub> (days)	AMAD µm	Ci/Co	Vd, clothing m/s	Contam Bq/m <sup>2</sup> cloth.	Half-life correct.	Dose rate, Sv/y per Bq/cm <sup>2</sup> at ca.0.4 mm (ICRU56)	Dose, Sv total	Dose, Sv total tissue/% weighted
I-131 or	1.79E+06	8	0.5	0.36	1.00E-03	644	0.0249	0.002637	4.24E-06	3.39E-08
Te-132	1.81E+07	3.25	0.7	0.5	1.70E-03	15385	0.0115	5.782E-5	1.03E-06	8.25E-09
Cs-134	8.93E+06	767	0.7	0.5	1.70E-03	7591	0.1140	0.002278	0.000197	1.58E-06
Cs-137	1.78E+07	10987	0.7	0.5	1.70E-03	15130	0.1182	0.003373	0.000603	4.83E-06
Ba-140	1.08E+07	12.8	4	0.12	2.70E-03	3499	0.0354	0.004284	5.32E-05	4.25E-07
Zr-95	2.67E+06	65.5	4	0.12	2.70E-03	865	0.0813	0.000752	5.29E-06	4.24E-08
Mo-99	5.18E+06	2.75	0.7	0.5	1.70E-03	4403	0.0099	0.005895	2.58E-05	2.07E-07
Ru-103	9.10E+06	39.6	0.7	0.27	1.70E-03	4177	0.0674	0.000243	6.84E-06	5.47E-08
Ru-106	2.28E+06	369	0.7	0.27	1.70E-03	1047	0.1096	0.010827	0.000124	9.94E-07
Ce-141	3.17E+06	32.5	4	0.12	2.70E-03	1027	0.0616	0.00148	9.38E-06	7.50E-08
Ce-144	2.14E+06	284.4	4	0.12	2.70E-03	693	0.1072	0.000251	1.86E-06	1.49E-08
Sr-89	1.32E+05	50.5	4	0.12	2.70E-03	42.8	0.0743	0.00784	2.49E-06	2.00E-08
Sr-90	1.41E+04	10585	4	0.12	2.70E-03	4.57	0.1182	0.002917	1.58E-07	1.26E-9
Np-239	1.68E+07	2.4	4	0.12	2.70E-03	5443	0.0087	~0	-	-
I-131 el.	1.77E+08	8		0.07	1.00E-02	123900	0.0249	0.002637	0.000816	6.52E-06

## Conclusions

From Table 4.8 it can be seen that with the air concentrations measured at Novozybkov, the total dose contribution received over a few months from gamma radiation from skin contamination amounts to about 52 µSv. This can be compared with the external dose contribution from contamination on other surfaces in the environment (e.g., soil, roofs, walls of buildings and pavings), which with a total deposition of only 8 kBq/m<sup>2</sup>, as was assumed in these calculations, would be in the order of 10-50 µSv over the first year, depending on the degree of shielding provided by the dwellings.

Dry deposition after the Chernobyl accident actually led to contamination of living areas in Russia with levels which were several hundred times higher. Here the skin contamination could give a gamma dose of several mSv.

It follows from Table 4.9 that the dose from the beta radiation to the epidermal layer of the directly exposed skin is about 8 mSv, in total. With a contamination level several hundred times greater than that, the skin dose would be several Sv. According to ICRP publication 59 the threshold for acute radiation effects by exposure of large areas of skin is generally assumed to be about 20 Sv, although acute tissue breakdown has been reported for doses as low as 15 Sv. These doses should also be compared with the risk of skin cancer mortality, which is estimated to be  $2 \cdot 10^{-4} \text{ Sv}^{-1}$  (ICRP 59).

The doses in the last column of Table 4.9 (total over isotopes=12.2  $\mu\text{Sv}$ ), which were weighted with the skin tissue weight factor and the percentage of the body not covered by clothes, make it possible to evaluate the effect of the skin irradiation relative to that from irradiation of other organs. However, this weighting may result in an under-estimation of the skin cancer risks. ICRP 59 states that the stochastic risks are dependent on the exposure of the area to sunlight (UVR). An exposure of all the skin that is normally exposed to UVR is said to give a risk comparable to that for whole-body exposure.

The doses received through a layer of clothing of 0.4 mm in thickness were in the Novozybkov case study found to amount to a total of about 2 mSv. In other words, the thin layer of cotton locally reduces the beta skin dose by a factor of about 4. As mentioned above this factor may be greater due to the air gap between the contaminated clothing and the skin.

As can be seen from the tables, in the Novozybkov example  $^{131}\text{I}$  has the highest relative importance in connection with all dose contributions related to skin contamination. This has to do with the large amount released, the high deposition velocity to skin and the short skin clearance half-life, which make the radiological half-lives somewhat less important. For all skin contamination dose pathways in the Novozybkov case, the caesiums ( $^{137}\text{Cs}$  and  $^{134}\text{Cs}$ ) give the second largest contribution.

#### 4.4.2 Decontamination in Russia

In the south west corner of the Briansk Region there are large areas that have been contaminated by the Chernobyl accident. The level of contamination exceeds  $1.5 \text{ MBq m}^{-2}$  in several villages and these have become more or less deserted. There is a need for decontamination, both to prevent further depopulation and to stimulate the return of the population to the affected areas.

In 1995 a joint Russian-Danish field exercise sponsored by the Danish Emergency Management Agency under the Ministry of the Interior decontaminated the area around three houses in Novo Bobovich 25 km north-north-west of Novozybkov. The work was carried out with hand tools, shovels and wheelbarrows, and monitored carefully with handheld dosimeters. Indoor dose reductions of 64 % and outdoor dose reductions of 78 % were achieved.

In 1997 a second field exercise obtained sponsorship. Here the focus was on application of heavy machinery in the decontamination work. An expedition from Risø National Laboratory went to the Novozybkov area in August 1997 with a bobcat (a mini bulldozer designed for work in gardens), an asphalt scraper and a skim and burial plough. An excavator and a tractor with a trailer were rented locally together with manual labour. The work was carried out in close collaboration between the Danish team and a team of five scientists from the Federal Radiological Center at the Institute of Radiation Hygiene in St. Petersburg.

The main effort during the expedition was the decontamination around three  $1\frac{1}{2}$  storey houses and of a grassed area in the recreational area Guta Muravinka situated at the the Iput river. This area initially received a  $^{137}\text{Cs}$  contamination of  $1.9 \text{ MBq m}^{-2}$  and it has been closed to public access until recently. The  $^{137}\text{Cs}$

distribution in the soil was undisturbed with 95 % of the contamination still remaining in the top 5 cm of the soil. The bobcat was used to remove the topsoil. Around the trees and houses hand tools were used. The excavator was applied to dig pits for the waste. Usually the bobcat moved the waste from temporary adjacent storage piles directly into the pits, but in a few cases the tractor was used to move the soil to further distances. The roof of one house was replaced in order to examine the influence of the roof contamination on the indoor dose rate.

In Figure 4.15 the effect of the decontamination on the dose rate is shown for three different locations: 1) Outdoors midway between houses 1 and 2 (about 7.5 m from the houses) 2) at the centre of the ground floor of house 1, and 3) at the centre of the first floor of house 1. The reductions were higher than those obtained in 1995. The 'sand added' entry in the figures refers to the sand from the excavation of the pits that was used to cover the area after the topsoil had been removed. Overall, the bobcat proved to be a tool which is very well suited for decontamination work in gardens and the successful completion of the project attracted attention from both the press and municipal authorities.

The skim-and-burial plough that is intended for decontamination of larger areas was tested at the Novo Bobovich state farm. The principle of the plough is to bury the topsoil (5 - 10 cm layer) at a depth of 40 to 50 cm without inverting the intermediate soil layer. The asphalt scraper was tested in the Novo Bobovich settlement. It removed 80 % of the contamination without difficulty, reducing the level of contamination of the asphalt from 250 to 50 kBq m<sup>-2</sup>.

### Dose reduction composition outdoors

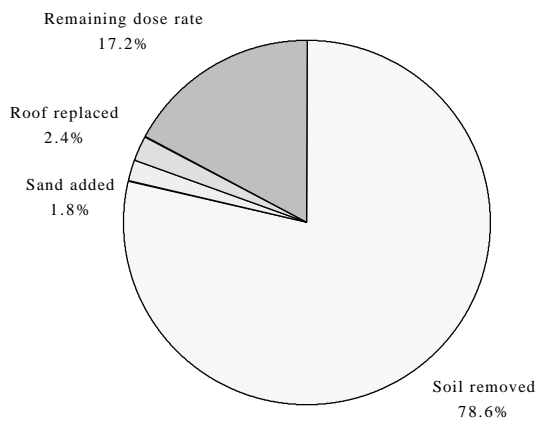

### Result of decontamination Ground floor of house 1

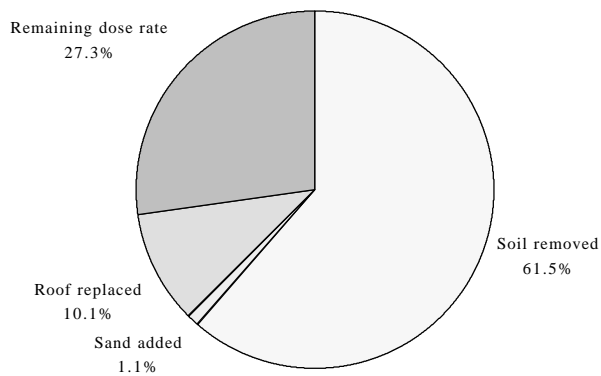

### Effect of decontamination 1st floor of house 1

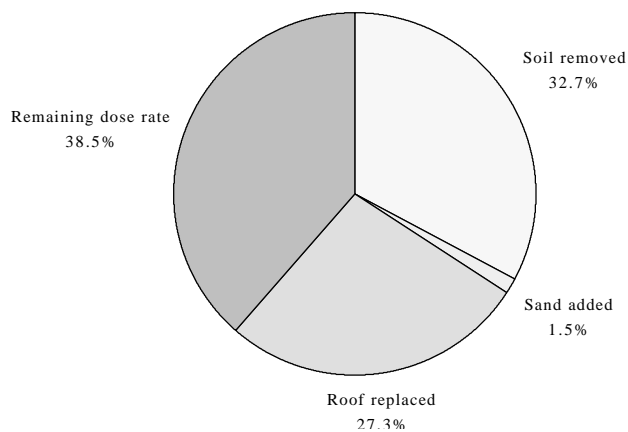

Figure 4.15 Dose reductions in three locations in Guta Muravinka.

## 4.5 Ecophysiology

### 4.5.1 Gill lipid metabolism and unidirectional $\text{Na}^+$ flux in the European eel (*Anguilla anguilla*) after transfer to dilute media: The formation of wax alcohols as a primary response

What is the mechanism involved when fish tighten their gill membrane after transfer to dilute media? Ten individually assayed eels adapted to freshwater (FW) and labelled with radioactive  $^{22}\text{Na}$  in the plasma showed mean exchange rates in equilibrium with ambient radioactive  $^{24}\text{Na}$  in FW at  $70 \mu\text{mol kg}^{-1} \text{h}^{-1}$ . Just after transfer to demineralized water (DW) the mean  $\text{Na}^+$  release rate went up to  $120 \mu\text{mol kg}^{-1} \text{h}^{-1}$ ; after 24 h in DW it came down again and levelled off at  $40 \mu\text{mol kg}^{-1} \text{h}^{-1}$  during a period of up to 2 weeks. During the same period the mean  $\text{Na}^+$  uptake rate was  $12 \mu\text{mol kg}^{-1} \text{h}^{-1}$ , i.e. the general picture in DW was a net  $\text{Na}^+$  loss. In another similar experiment, groups of 3 FW-adapted eels were incubated *in vivo* for up to 24 h with ( $^{14}\text{C}$ ) acetate added as lipid precursor to the ambient water. Incubation in FW showed about 20% of the total  $^{14}\text{C}$ -activity incorporated into gill lipids as ( $^{14}\text{C}$ ) wax alcohols (octadecanol and eicosanol). This percentage went up to 50% shortly after transfer to DW and came down again to about 20% after 2 weeks in DW. Single eels labelled with  $^{22}\text{Na}$  in the plasma showed a statistically significant positive linear correlation of % ( $^{14}\text{C}$ ) wax alcohols with  $\log [^{22}\text{Na} \text{ efflux}]$ . Based on the observed parallel between  $\text{Na}^+$  flux and gill lipid metabolism, we suggest that the eel reacts at first to a loss of  $\text{Na}^+$  by synthesizing wax alcohols that can tighten the gill membrane.

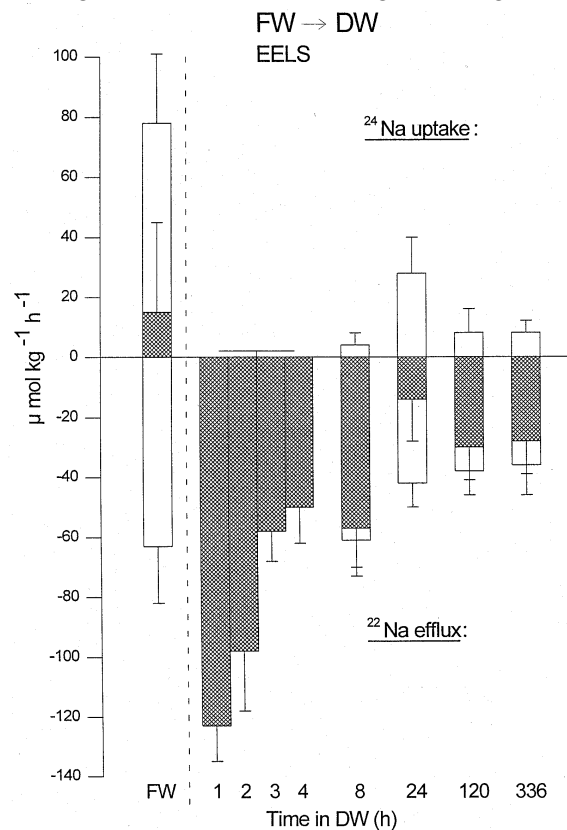

Figure 4.16. The effect of acclimation to demineralized artificial fresh water (DW) on whole-body sodium fluxes in the same group of eels, *Anguilla anguilla* ( $N = 10$ ), determined as means of results from 7 successive 0.5 h flux periods during the first 4 h in DW and since as means of two successive 1 h flux periods. Each eel was assayed separately. Open bars indicate unidirectional  $\text{Na}^+$  fluxes and shaded areas, net  $\text{Na}^+$  fluxes.

FW → DW

EEL GILLS

$^{14}\text{C}$ -wax alcohols (%)

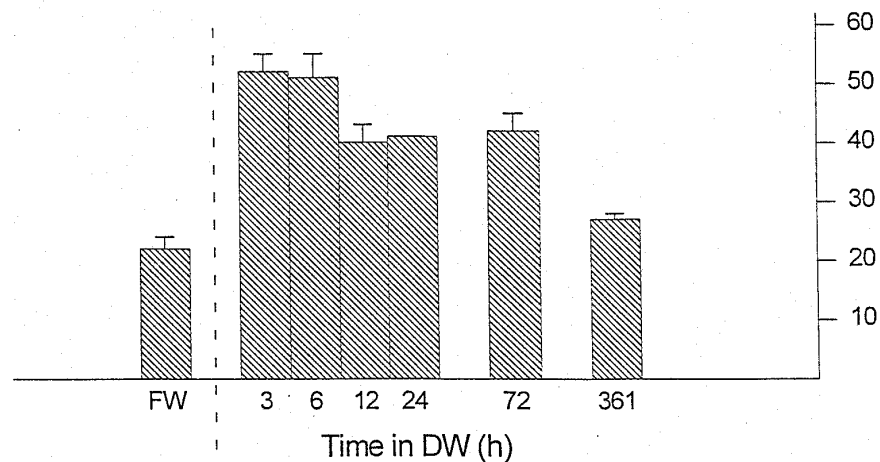

Figure 4.17. The incorporation in vivo into gill wax alcohols of ( $1\text{-}^{14}\text{C}$ ) acetate, added to the water in the incubation tank, expressed as % of total ( $^{14}\text{C}$ ) lipids. Presented as a function of time in DW, similar to Figure 4.16; means  $\pm$  SEM of groups of 3 individually assayed eels.

#### 4.5.2 Cu uptake and turnover in both Cu-acclimated and non-acclimated rainbow trout (*Oncorhynchus mykiss*)

Cu-64 accumulation and total Cu concentrations were measured in plasma, red blood cells, gills, liver, kidney and bile during 65 h of exposure to  $^{64}\text{Cu}$  at  $20\ \mu\text{g}$  of Cu per litre, in non acclimated and Cu acclimated (28 days of preexposure) rainbow trout (*Oncorhynchus mykiss*) fitted with a dorsal aortic catheter. By measuring both  $^{64}\text{Cu}$  accumulation and total Cu concentrations, we were able to analyse the ongoing uptake and turnover of ambient Cu, independent of any Cu already present in the fish.

Plasma accounted for at least 90% of the  $^{64}\text{Cu}$  present in the blood and Cu-acclimation clearly involves changes in copper accumulation kinetics in the plasma. The acclimated fish showed a 65% reduced  $^{64}\text{Cu}$  accumulation after 65 h and an increased turnover of Cu in the plasma compared to the non-acclimated fish. Total Cu in the plasma increased by 59% after 3 h of exposure in the non-acclimated fish but was recovered during the following 24 h and remained at control levels throughout 65 h; even after 28 days the acclimated fish showed no increase in total plasma [Cu]. Apparently Cu acclimation involves an increased clearing of plasma Cu, primarily to the liver, stimulated during the first 12 h of exposure.

Acclimation did not have an unambiguous effect on branchial Cu uptake and differences in branchial uptake could not explain the reduced accumulation in



the plasma. The rapidly exchangeable Cu pools were 54% in the gills and 33% in the liver, suggesting a considerable hepatic Cu elimination. No increase in the total [Cu] in the kidney was observed, but the kidney did show substantial  $^{64}\text{Cu}$  accumulation and thus also a potential renal Cu excretion.

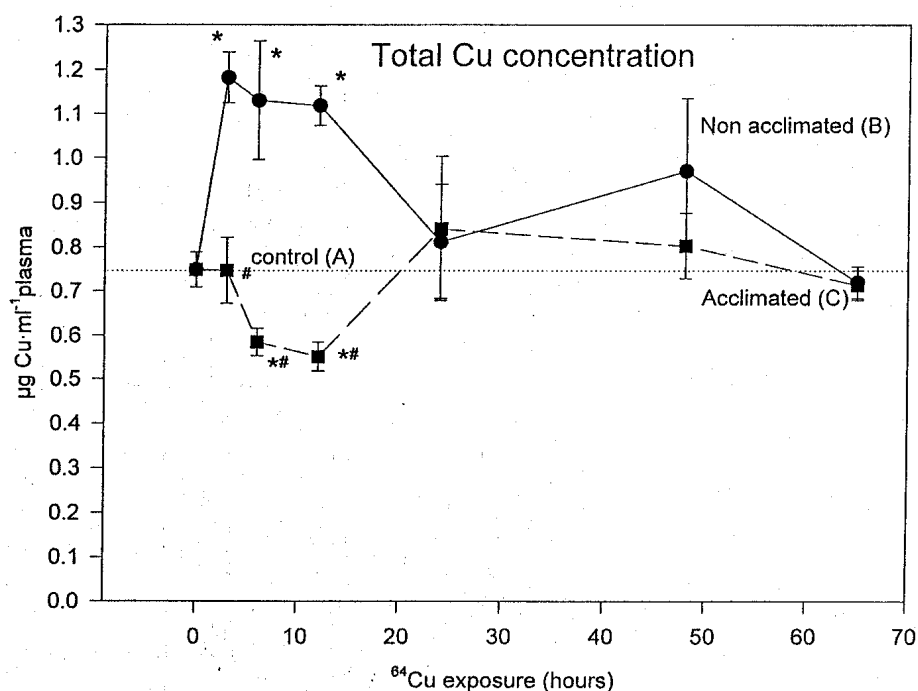

Figure 4.18. Total Cu concentration in plasma of non-acclimated (●) and Cu-acclimated (■) rainbow trout during 65 h of  $^{64}\text{Cu}$  exposure at 20 µg of Cu per litres. Means  $\pm$  SEM ( $N = 10$  for controls and for non acclimated and  $N = 9$  for acclimated). Values of the acclimated fish (C) were tested statistically against the corresponding values for non-acclimated fish (B) by an unpaired t-test, using Bonferroni correction for multiple sample comparison. A significant difference between B and C, at  $P < 0.05$ , is indicated by #. Values from both (B) and (C) were tested against the controls by unpaired t-tests. A significant difference from the controls (A), at  $P < 0.05$ , is indicated by \*

## 5 Radioanalytical chemistry

The fundamental purpose of the programme in radioanalytical chemistry is to develop reference methods and provide traceability for the determination of trace elements in the environment. Our main direction of research has been the analysis of biological materials, and in particular we have continued our work to contribute to the certification of European reference materials by BCR.

Certification analysis of human serum and urine was completed in cooperation with the National Institute for Occupational Health. This was carried out as an EU project for SM&T in Brussels. The element As was determined by radiochemical neutron activation analysis (RNAA), while Se and Zn were determined by instrumental neutron activation analysis (INAA).

Concerning recertification of the reference materials mussel tissue and bovine liver for IRMM in Geel As, Cu and Pt were determined by RNAA and Mn, Se, Cr and Zn by INAA.

An intercomparison for SM&T of a polymer reference material was performed in co-operation with DSM Research in Holland. The elements Cl, Br, As, Cd, Cr and Hg were determined by INAA.

Another intercomparison was performed for SM&T in co-operation with Mermayde in Holland. The rare earth elements La, Sm and Eu were determined together with Sc and Th in duck weed and mussel tissue by INAA. The same elements were determined together with Ce and Dy in sediment samples also by INAA.

INAA was used as a QC/QA method for the determination of trace elements in vegetables by ICP-MS for the FØTEK project. A joint paper was presented at the 6th Nordic Symposium on Trace Elements in Human Health and Disease in Roskilde.

In co-operation with Copenhagen University Hospital the determination of Pt in various organs of monkeys treated with cisplatin has begun.

Co-operation with the Technical University in Munich and the Danish Environmental Institute in the field of air filter samples for the determination of environmental exposure to Pt continues, but remains unfunded.

The co-operation with the John F. Kennedy Institute has continued with the determination of Cu in 20 chorionic villi and placenta samples by RNAA for the diagnosis and verification of Menkes disease.

## 6 Nuclear facilities

### 6.1 Research reactor DR 3

DR 3 is a heavy water moderated and cooled nuclear research reactor which has been in operation since 1960. It was originally built as a materials testing reactor, but today it is used as a multipurpose research reactor. The operation cycle is 4 weeks, of which 23½ days is continuous operation and 4½ days is shut down. The vertical experimental facilities comprise 13 tubes in the core, 50 mm diameter, and 14 tubes in the D<sub>2</sub>O and graphite reflectors with sizes ranging from 10 to 18 cm in diameter. Four tubes, 18 cm diameter, pass horizontally and tangentially to the core. These facilities were intended for loop experiments, but turned out to be excellent beam ports. Two beam ports are supplied with thermal neutrons from a water scatterer, two others are supplied with cold neutrons from a 38 K cold hydrogen neutron source.

Six three-axis spectrometers and a Small Angle Neutron Scatterer (SANS) instrument are supplied by the neutron beams from the four beam ports belonging to the tangential 18 cm diameter tubes. One of the cold source beam ports is connected to a building outside the reactor hall, by means of a neutron guide tube. The monochromatic cold neutron flux at the sample position is:  $7 \cdot 10^6 \text{ n cm}^{-2} \text{ s}^{-1}$  ( $E_n = 5 \text{ meV}$ ). Two of the three-axis spectrometers are multipurpose instruments with a high degree of flexibility, facilitated by five different detector arms which can be attached or detached in less than one hour.

Neutron scattering is an important technique for the study of large molecules such as polymers and biological molecules and for the study of superconductivity and magnetism in high-temperature super-conductors. These are examples of recent applications of the beam facilities of DR 3. DR 3 is

appointed as a Large European Beam Facility and the neutron beam instruments are intensively utilized by researchers from Risø and from other EU-countries.

The neutrons from DR 3 are also used for activation analysis, isotope production and transmutation doping of silicon. These activities are described in section 5 and section 6.2.

In 1997 an extra facility for irradiation of 5 inch silicon crystals was installed in the reactor.

The reactor was kept in operation at 10 MW for 7084 hours corresponding to 81% of the year. The availability is high. A number of short reactor stops gave an unscheduled down time of only 8 hours.

## 6.2 Isotope Laboratory

### 6.2.1 Basic irradiation service

This section continues to fulfil our commitment to cover all needs for neutron-irradiated materials for technical and scientific purposes in Denmark. The Isotope Laboratory is responsible for the production of radioactive isotopes and other radioactive materials for industry, hospitals, and research institutions. An increasing part of the deliveries to domestic as well as foreign customers is unprocessed irradiations from dedicated reactor irradiation facilities. All radioactive materials needed for Risø's own research are made as ready-to-use preparations.

A total of 1100 irradiations were carried out for use by Risø and 32 different external customers in Denmark, Sweden, Finland, Germany, Switzerland, Italy, and the U.K. The number of dispatched batches of  $\text{NH } ^{82}\text{Br}$  has grown to the 1995 level because there have not been any prolonged DR3 shut down periods like in 1996, and the number of scientific customers from abroad using irradiations in the thermal neutron facility for fission track and argon-argon dating of rocks is still increasing. Altogether 109 shipments of other radioactive products were sent to a variety of institutes, industry and hospitals, the lower figure reflects the cessation of radiopharmaceutical production

In October a quality manual for the transport of radioactive material was completed and implemented. At the end of the year the transport of radioactive materials by the Isotope Laboratory was discontinued after more than 37 years, and tenders have been invited from a number of forwarding agents.

For research applications at Risø, 84 irradiations were performed and 97 deliveries of radioisotopes in specially prepared forms were made. For educational purposes 449 solid radioactive sources were supplied to the Nordic countries.

### 6.2.2 NTD silicon

Neutron transmutation doping of silicon takes place in seven facilities in the DR3 reactor. Three facilities are placed in the heavy water in vertical positions, and one facility is placed in a horizontal position in the heavy water.

In accordance with plans a new horizontal 5" facility was installed in DR3 in 1997. The test phase is expected to be completed in the beginning of 1998, and commercial irradiation of silicon will start in this facility.

The Danish Standard Association approved the quality management system at its annual audit, and renewed the ISO 9002 certificate.

Chemically doped silicon is presenting a great competition to NTD silicon; nevertheless our production of NTD silicon increased in 1997, primarily based on 5" silicon crystals.

## 6.3 Waste Management Plant

Safe management of radioactive waste products from Risø and from other Danish users of radioactive substances is the primary purpose of the Waste Management Plant. In addition collection of chemically toxic waste, purification of ordinary waste water and decontamination and laundry facilities are taken care of. Research concerning properties of waste materials and related topics are described in section 3.5. Staff from the Waste Management Plant participate in international organisations concerned with radioactive waste, notably EU - DGXI (Environment).

### 6.3.1 Radioactive waste

Waste materials containing radioactive isotopes above limits specified by the Danish Institute for Radiation Hygiene must be stored at Risø in the facilities run by the Waste Management Plant. This service is available on a commercial basis for Danish industry, research institutes and hospitals. The Waste Management Plant also runs an external waste collection service.

The treatment methods are unchanged from previous years:

A balling press is used for compacting low-level solid waste. In 1997 3.0 t out of totally 6.4 t was coming from outside Risø. The external waste contained about 298 GBq radioisotopes with half-life longer than 1 year, mostly in form of closed sources. Larger spent sources are stored separately.

Low-level radioactive waste water from the nuclear facilities and laboratories has been purified by distillation since the start of the research centre in 1958. The evaporation plant is very energy economic and constructed according to a Danish patent. It is a steam recompression plant with forced circulation of the concentrate through the heat exchanger where condensation of the compressed steam takes place. Late in 1997 the plant had distilled a total of 100 000 m<sup>3</sup>. The plant is constructed of stainless steel, and although the concentrate contains considerable chloride, no significant corrosion problems have been encountered during the nearly 40 years of operation. The decontamination factor concentrate / distillate is of the order of 10<sup>6</sup> corresponding to about 10<sup>4</sup> for the feed water versus the distillate. The concentrate is evaporated to dryness and conditioned in a small bituminization plant. The solid materials encapsulated in the bitumen consists of sludge particles and salt crystals, mainly sodium sulphate and chloride. No nitrate is present which greatly diminish the fire risk associated with such plants. The treatment of 1600 m<sup>3</sup> waste water in 1997 gave rise to about 1.4 t bituminized material containing about 1.3 GBq mixed  $\beta$ -emitters. Although the content of long-lived activity has diminished after the Risø Hot Cells were taken out of use some  $\alpha$ -contamination seems still to be present in the equipment.

The release to the recipient Roskilde Fjord with the purified waste water and other sources was ~64 MBq mixed  $\beta$ -emitters ( 0.9 % of permitted release), where a considerable part is natural activity in form of <sup>40</sup>K in ordinary purified sewage water. In addition 3700 GBq of tritiated water were released to the fjord and about 8.0 GBq <sup>14</sup>C-carbon dioxide to the atmosphere. The isotopes originates from the heavy water moderated DR3 reactor.

The treatment procedures resulted in a total of 72 drums containing bituminized evaporator concentrate or compacted low-level waste. No medium-level waste was stored but some depleted uranium received for safe-keeping at Centralvejslageret.

The low-level drums were placed in the Risø Storage Hall for low-level waste which presently contains 4425 drums, including old units which from 1993-96 were transferred from the previous somewhat unsatisfactory storage

area Betonrørslageret. This site still contains the concrete structures used previously for storage of the drums. The extensive control measurements needed for declassification of the concrete structures and the site has been postponed to 1998. Planning for an extension of Centralvejslageret used for storage of waste with high radiation or containing fissile materials was also postponed.

The storage facilities at Risø are only for temporary use but eventually the waste must be disposed of permanently. Actual planning for such a disposal has not been carried out but relevant information about the waste types and possible disposal concepts are collected in connection with research carried out at the Waste Management Plant.

### 6.3.2 Inactive systems

The purification system for ordinary sewage water from the Risø area has been reconstructed so that also nitrogen components are removed. The new plant has now operated for 1½ years and seems to function satisfactorily although break down of some mechanical components have resulted in periods with less than optimal performance of the system. This is reflected in the variation in total nitrogen concentration in the purified water as shown in Figure 6.1. However, taken as a mean over 1997 the plant was just able to fulfil the release limits for nitrogen. Purification for organic components was excellent. The plant treated 48900 m<sup>3</sup> in 1997 and prevented the release of about 1 t nitrogen and 5 t BOD (organic components expressed as biological oxygen demand).

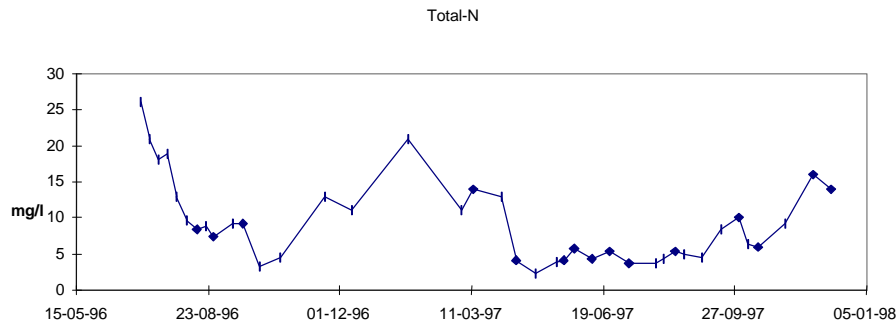

Figure 6.1. . Concentrations of total nitrogen (in nitrate, ammonia and organic components) in effluent from the biological sewage purification plant at Risø. The new plant was taken in use in the summer 1996. The permissible concentration is 6 mg N/L expressed a weight mean of the analyses over one year.

The other services of the Waste Management Plant (collection of chemical waste, decontamination of protective clothing and ordinary laundry facilities) were operated as in previous years although reductions in the staff has given some problems.

## 6.4 Educational reactor DR 1

Activities at the DR 1 reactor have concentrated on courses on experimental reactor physics for university students and high-school classes.

### Education

The reactor has been used almost exclusively for educational purposes. About 40 high school classes have carried out one-day or half-a-day experiments at the reactor. The total number of high school pupils visiting DR 1 in 1997 was about 700.

A number of students from the Technical University of Denmark have carried out experiments at the reactor over a period of three weeks. Some of the experiments are:

- Determination of the reactor's temperature-, power, and bubble-coefficients
- Neutron activation analysis
- Measurements of neutron cross sections
- Neutron radiography
- Health physics experiments
- Core flux distribution measurements.

### Safety documentation

The safety documentation for DR 1 was revised and forwarded to the nuclear safety authorities.

## 7 Other tasks

### 7.1 Personnel dosimetry

Risø's personnel dosimetry service covers the individual monitoring of the personnel at Risø and the Niels Bohr Institute Tandem Accelerator. Only persons actually involved in radiation work are equipped with a personal dosimeter. In areas where the use of personal dosimeters are not required, the radiation levels are controlled through an extensive area-monitoring programme using thermoluminescence (TL) dosimeters.

The main statistics of the dosimetry service for 1997 are shown in Table 7.1 and Figure 7.1.

Table 7.1. Statistics for monitoring of Risø Personnel in 1997.

No. of persons monitored	740
No. of persons receiving external doses above 0.2 mSv (the registration level)	154
No. of persons receiving internal doses from intake of tritiated water	43
Total collective equivalent dose to the monitored personnel:	
External doses	162 mSv
Internal doses	<u>6 mSv</u>
Total	168 mSv

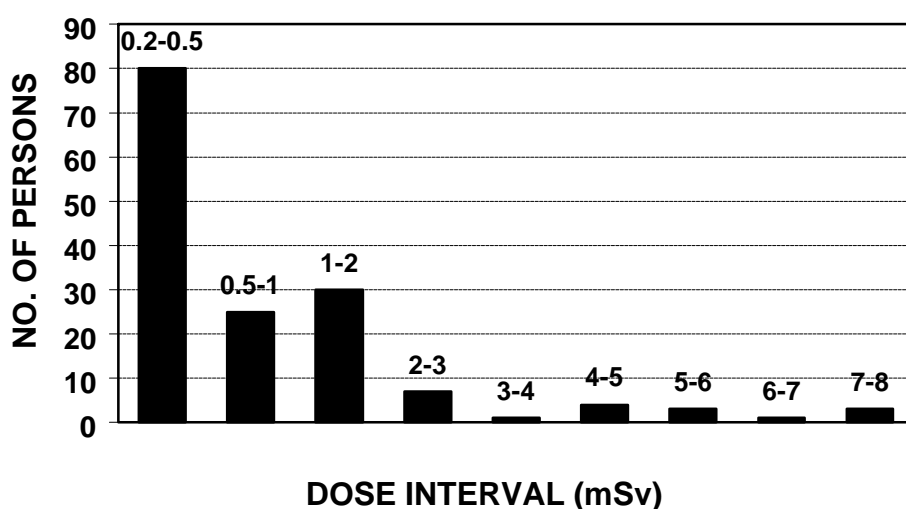

Figure 7.1. Distribution of whole-body doses (effective doses) in 1997.

A new quality assurance programme introduced in 1996 for the personnel routine monitoring service has been evaluated. For each monthly issue of the routine dosimeters a number of extra dosimeters which had previously been given known irradiation doses were like the routine dosimeters sent to three different areas at Risø, i.e. DR3, Isotope Laboratory and Personal Dosimetry Laboratory where they were kept at selected locations. At the end of each monthly monitoring period the test dosimeters were returned to the Personal Dosimetry Laboratory and evaluated together with the routine dosimeters.

The test doses used were 0.25, 0.5, 1 and 5 mSv. Background were corrected for using unirradiated dosimeters at the three locations. The test programme has given valuable information on the general performance of the dosimetry system and it is concluded that a continuous use of the programme will give a constant contribution to the quality assurance of the dosimetry service. An example of the data obtained from the test programme is shown in Figure 7.2 illustrating that the current uncertainty of the system for the measurement of a dose of 0.25 mSv is within  $\pm 20\%$

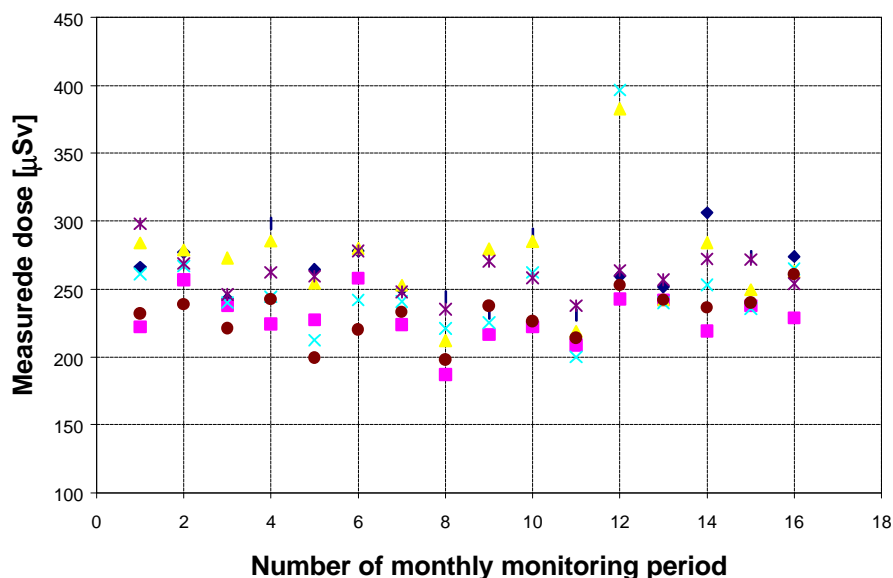

Figure 7.2. Results from evaluation of 0.25 mSv test doses.

## 7.2 Environmental monitoring

The department is responsible for the environmental monitoring of Risø. The programme carried out for this purpose comprises regular monitoring of air, precipitation, sediments, seawater, grass, seaplants, milk and waste-water from the waste treatment station. The samples are measured for gamma-activity by Ge-Li- $\gamma$ -spectrometry and furthermore some samples are measured for tritium and gross beta activity. External gamma radiation is monitored at 25 stations around Risø.

The results are reported in semi-annual reports in the series "Radioactivity in the Risø District--"

The results of the latest report from January-June 1997 showed that the mean concentrations in air were  $0.58 \mu\text{Bq } ^{137}\text{Cs m}^{-3}$ ,  $3.6 \text{ mBq } ^7\text{Be m}^{-3}$  and  $0.2 \text{ mBq } ^{210}\text{Pb m}^{-3}$ . The background dose rate measured by TLD in the Risø area was  $105 \text{ nSv h}^{-1}$  compared with  $84 \text{ nSv h}^{-1}$  outside Risø. None of the measured concentrations were of any concern from a radiation protection point of view and the levels were similar to those observed in 1996.

# 8 Publications

## 8.1 International publications

Aarkrog, A.; Baxter, M.S.; Bettencourt, A.O.; Bojanowski, R.; Bologna, A.; Charmasson, S.; Cunha, I.; Delfanti, R.; Duran, E.; Holm, E.; Jeffree, R.; Livingston, H.D.; Mahapanyawong, S.; Nies, H.; Osvath, I.; Li Pingyu; Povinec, P.P.; Sanchez, A.; Smith,



- J.N.; Swift, D., A comparison of doses from  $^{137}\text{Cs}$  and  $^{210}\text{Po}$  in marine food: A major international study. *J. Environ. Radioact.* (1997) v. 34 p. 69-90
- Aarkrog, A.; Chen, Q.; Dahlgaard, H.; Nielsen, S.P.; Trapeznikov, A.; Pozolotina, V., Evidence of  $^{99}\text{Tc}$  in Ural River sediments. *J. Environ. Radioact.* (1997) v. 37 p. 201-213
- Aarkrog, A.; Dahlgaard, H.; Nielsen, S.P.; Trapeznikov, A.V.; Molchanova, I.V.; Pozolotina, V.N.; Karavaeva, E.N.; Yushkov, P.I.; Polikarpov, G.G., Radioactive inventories from the Kyshtym and Karachay accidents: estimates based on soil samples collected in the South Urals (1990-1995). *Sci. Total Environ.* (1997) v. 201 p. 137-154
- Andersen, C.E.; Bergsøe, N.C.; Majborn, B.; Ulbak, K., Radon and natural ventilation in newer Danish single-family houses. *Indoor Air* (1997) v. 7 p. 278-286
- Bøtter-Jensen, L., Luminescence techniques: Instrumentation and methods. *Radiat. Meas.* (1997) v. 27 p. 749-768
- Bøtter-Jensen, L.; Larsen, N.A.; Markey, B.G.; McKeever, S.W.S.,  $\text{Al}_2\text{O}_3\text{C}$  as a sensitive OSL dosimeter for rapid assessment of environmental photon dose rates. *Radiat. Meas.* (1997) v. 27 p. 295-298
- Christensen, P., Dosimetry of beta and low-energy photon radiation. In: Nuclear fission safety programme 1992-1994. Radiation protection research action. Final report. Vol. 1. EUR-16769 (1997) p. 345-354
- Duller, G.A.T.; Bøtter-Jensen, L., Optically stimulated luminescence emission spectra from feldspars as a function of sample temperature. *Radiat. Meas.* (1997) v. 27 p. 145-151
- Duller, G.A.T.; Bøtter-Jensen, L.; Markey, B.G., A luminescence imaging system based on a CCD camera. *Radiat. Meas.* (1997) v. 27 p. 91-99
- Fogh, C.L.; Byrne, M.A.; Roed, J.; Goddard, A.J.H., Size specific indoor aerosol deposition measurements and derived I/O concentrations ratios. *Atmos. Environ.* (1997) v. 31 p. 2193-2203
- Grosell, M.H.; Hogstrand, C.; Wood, C.M., Cu uptake and turnover in both Cu-acclimated and non-acclimated rainbow trout (*Oncorhynchus mykiss*). *Aquat. Toxicol.* (1997) v. 38 p. 257-276
- Heydorn, K., Comments on definitions of analytical terms. *Accred. Qual. Assur.* (1997) v. 2 p. 204-205
- Heydorn, K.; Damsgaard, E., Validation of a loss-free counting system for neutron activation analysis with short-lived indicators. *J. Radioanal. Nucl. Chem.* (1997) v. 215 p. 157-160

- Heydorn, K.; Damsgaard, E.; Gwozdz, R., Quality assurance of hair analysis for evaluation of environmental pollution. American Nuclear Society 1997 Winter meeting, Albuquerque, NM (US), 16-20 Nov 1997. Trans. Am. Nucl. Soc. (1997) v. 77 p. 33
- Højerup, F.; Miettinen, J.; Nilsson, L.; Puska, E.K.; Sjövall, H.; Anttila, M.; Lindholm, I., On recriticality during reflooding of a degraded boiling water reactor core. NKS-RAK-2(97)TR-A3 (1997) 80 p.
- Kristensen, L.; Andersen, C.E.; Jørgensen, H.E.; Kirkegaard, P.; Pilegaard, K., First-order chemistry in the surface-flux layer. J. Atmos. Chem. (1997) v. 27 p. 249-269
- Lindholm, I.; Berg, Ø.; Nonbøl, E., Safety against releases in severe accidents. Annual report 1996. NKS-RAK-2(96)AR-1 (1997) 19 p.
- Lindholm, I.; Hedberg, K.; Thomsen, K.; Ikonen, K., On core debris behaviour in the pressure vessel lower head of Nordic boiling water reactors. NKS/RAK-2(97)TR-A4 (1997) 84 p.
- Markey, B.G.; Bøtter-Jensen, L.; Duller, G.A.T., A new flexible system for measuring thermally and optically stimulated luminescence. Radiat. Meas. (1997) v. 27 p. 83-89
- McKeever, S.W.S.; Bøtter-Jensen, L.; Agersnap Larsen, N.; Duller, G.A.T., Temperature dependence of OSL decay curves: Experimental and theoretical aspects. 8. International conference on luminescence and electron spin resonance dating, Canberra (AU), 22-26 Apr 1997. Radiat. Meas. (1997) v. 27 p. 161-170
- McKeever, S.W.S.; Larsen, N.A.; Bøtter-Jensen, L.; Mejdahl, V., OSL sensitivity changes during single aliquot procedures: Computer simulations. Radiat. Meas. (1997) v. 27 p. 75-82
- McKeever S.W.S., Bøtter-Jensen L., Agersnap Larsen N. and Duller G.A.T. (1997) Temperature dependence of OSL decay curves: experimental and theoretical aspects. Radiat. Meas., 27, 161-170.
- Mejdahl, V.; Bøtter-Jensen, L., Experience with the SARA OSL method. 8. International conference on luminescence and electron spin resonance dating, Canberra (AU), 22-26 Apr 1997. Radiat. Meas. (1997) v. 27 p. 291-294
- Mitchell, P.I.; León Vitró, L.; Dahlgaard, H.; Gascó, C.; Sánchez-Cabeza, J.A., Perturbation in the  $^{240}\text{Pu}/^{239}\text{Pu}$  global fallout ratio in local sediments following the nuclear accidents at Thule (Greenland) and Palomares (Spain). Sci. Total Environ. (1997) v. 202 p. 147-153
- Nielsen, S.P.; Iosjpe, M.; Strand, P., Collective doses to man from dumping of radioactive waste in the Arctic Seas. Sci. Total Environ. (1997) v. 202 p. 135-146
- Nielsen, S.P.; Nies, H., Artificial radionuclides. In: Third

periodic assessment of the state of the marine environment of the Baltic Sea, 1989-93. Background document (HELCOM, 1996). (Helsinki Commission. Baltic Marine Environment Protection Commission, Helsinki, 1996) (Baltic Sea Environment Proceedings, 64B) p. 154-157

Poolton N.R.J., Bøtter-Jensen L. and Johnsen O. (1997) A search for IRSL-active dosimeters with enhanced sensitivity: A spectroscopic survey. *Radiat. Meas.*, 27, 279-290.

Rietz, B.; Heydorn, K.; Pritzl, G., Determination of aluminium in fish tissues by means of INAA and ICP-MS. *J. Radioanal. Nucl. Chem.* (1997) v. 216 p. 113-116

Roed, J., The urban environment. Part 1. In: Strand, P.; Skuterud, L.; Melin, J. (eds.), Reclamation of contaminated urban and rural environments following a severe nuclear accident. Nordic nuclear safety research. BER 6. NKS(97)18 (1997) p. 1-17

Scott, E.M.; Gurbutt, P.; Harms, I.; Heling, R.; Nielsen, S.P.; Osvath, I.; Preller, R.; Sazykina, T.; Wada, A.; Sjoebloom, K.L., Benchmarking of numerical models describing the dispersion of radionuclides in the Arctic Seas. *Sci. Total Environ.* (1997) v. 202 p. 123-134

Strand, P.; Balonov, M.; Aarkrog, A.; Bowers, M.J.; Howard, B.; Salo, A.; Tsaturov, Y.S., Arctic pollution issues: Radioactive contamination. A report from an international expert group to the Arctic Monitoring and Assessment Programme. (1997) 160 p.

Strandberg, M., Distribution of  $^{137}\text{Cs}$  in a low arctic ecosystem in West Greenland. *Arctic* (1997) v. 50 p. 216-223

Tschiersch, J.; Busch, B.; Fogh, C.L., Measurements of concentration, size distribution and hygroscopicity of Munich winter aerosol. *J. Aerosol. Sci. Suppl.* (1997) v. 28 p. S209-S210

Vuori, S.; Brodén, K.; Carugati, S.; Brodersen, K.; Walderhaug, T.; Helgason, J.; Sneve, M.; Hornkjøl, S.; Backe, S., Performance analysis for waste repositories in the Nordic countries. Report for project AFA-1.2. NKS/AFA-1(96)8 (1997) 64 p.

## 8.2 Danish publications

Aarkrog, A., Contaminants in the Greenland marine environment. Radionuclides. In: AMAP Greenland 1994-1996. Arctic Monitoring and Assessment Programme. (Danish Environmental Protection Agency, Copenhagen, 1997) (Environmental project, 356) p. 217-240, 557-566

Aarkrog, A., Contaminants in the Greenland terrestrial and freshwater

environment. Radionuclides. In: AMAP Greenland 1994-1996. Arctic Monitoring and Assessment Programme. (Danish Environmental Protection Agency, Copenhagen, 1997) (Environmental project, 356) p. 623-652, 779-788

Aarkrog, A.; Chen, Q.J.; Clausen, J.; Christensen, G.C.; Dahlgaard, H.; Ellis, K.; Hansen, H.; Holm, E.; Joensen, H.P.; Nielsen, S.P.; Strandberg, M., Environmental radioactivity in the North Atlantic Region including the Faroe Islands and Greenland. 1992 and 1993. Risø-R-757(EN) (1997) 132 p.

Andersen, C.E.; Bergsøe, N.C.; Brendstrup, J.; Damkjær, A.; Gravesen, P.; Ulbak, K., Radon-95: En undersøgelse af metoder til reduktion af radonkoncentrationen i danske enfamiliehuse. Risø-R-979(DA) (1997) 108 p.

Hoff, A., Radon transport in fractured soil: Laboratory experiments and modelling. Risø-R-975(EN) (1997) 150 p. (ph.d. thesis)

Højerup, C.F.; Majborn, B.; Ølgaard, P.L. (eds.), International kernekraftstatus 1996. Risø-R-966(DA) (1997) 75 p.

### 8.3 Publications in proceedings

Aarkrog, A., Radioactive contamination of the marine environment. In: Health impacts of large releases of radionuclides. Symposium on health impacts of large releases of radionuclides, St. Petersburg (RU), 27-29 Feb 1996. Lake, J.V.; Bock, G.R.; Cardew, G. (eds.), (John Wiley & Sons, Chichester, 1997) (Ciba Foundation Symposium, 203) p. 68-73

Aarkrog, A., Doses to the Arctic population. In: The third international conference on environmental radioactivity in the Arctic. Extended abstracts. Vol. 2. The AMAP international symposium on environmental pollution of the Arctic and 3. International conference on environmental radioactivity in the Arctic, Tromsø (NO), 1-5 Jun 1997. (Norwegian Radiation Protection Authority, Østerås, 1997) p. 113-114

Aarkrog, A., Radioecology, development and trends. In: Proceedings. Nordisk Selskap for Strålevern, det 11. ordinære møtet. Det 7. Nordiske radioøkologi seminar. Nordisk Selskap for Strålevern, 11. ordinære møte; 7. Nordiske radioøkologi seminar, 26-29 Aug 1996, Reykjavik (IS). Walderhaug, T.; Gudlaugsson, E.P. (eds.), (Nordic Radiation Protection Society, Reykjavik, 1997) p. 567-573

Ali, S.M.; Beaumont, H.M.; Dutton, L.M.C.; Handy, B.J.; Hosty, M.; Parsons, A.F.; Nielsen, S.P.; Sivintsev, Y.; Lystsov, V.; Yefimov, E.I.; Sazykina, T.; Zheleznyak, M.; Maderich, V.; Nargvelashvily, N.Y.; Cecille, L., The radiological consequences of the marine reactors scuttled in the Kara Sea. In: The third international conference on environmental radioactivity in the Arctic. Extended abstracts. Vol. 2. The AMAP international symposium

on environmental pollution of the Arctic and 3. International conference on environmental radioactivity in the Arctic, Tromsø (NO), 1-5 Jun 1997. (Norwegian Radiation Protection Authority, Østerås, 1997) p. 28-31

Bøtter-Jensen, L., Retrospective radiation dosimetry using optically stimulated luminescence on natural materials and ceramics for assessing population doses in nuclear accidental areas. In: Proceedings. Nordisk Selskap for Strålevern, det 11. ordinære møtet. Det 7. Nordiske radioøkologi seminar. Nordisk Selskap for Strålevern, 11. ordinære møte; 7. Nordiske radioøkologi seminar, 26-29 Aug 1996, Reykjavik (IS). Walderhaug, T.; Gudlaugsson, E.P. (eds.), (Nordic Radiation Protection Society, Reykjavik, 1997) p. 273-278

Christensen, J.M.; Kristiansen, J.; Heydorn, K.; Damsgaard, E.; Cornelis, R., Candidate BCR reference materials for arsenic and selenium determinations in human serum and urine. In: Harmonization of health related environmental measurements using nuclear and isotopic techniques. International symposium on harmonization of health related environmental measurements using nuclear and isotopic techniques, Hyderabad (IN), 4-7 Nov 1996. (International Atomic Energy Agency, Wien, 1997) p. 213-221

Christensen, P., Dosimetry of beta and low-energy photon radiation: Standardisation, individual dosimetry and monitoring of the workplace. In: Proceedings. Nordisk Selskap for Strålevern, det 11. ordinære møtet. Det 7. Nordiske radioøkologi seminar. Nordisk Selskap for Strålevern, 11. ordinære møte; 7. Nordiske radioøkologi seminar, 26-29 Aug 1996, Reykjavik (IS). Walderhaug, T.; Gudlaugsson, E.P. (eds.), (Nordic Radiation Protection Society, Reykjavik, 1997) p. 279-284

Dahlgaard, H., Polonium-210 in mussels and fish from the Baltic-North Sea estuary. In: Freshwater and estuarine radioecology. Proceedings of an international seminar. Lisbon (PT), 21-25 Mar 1994. Desmet, G.; Blust, R.J.; Comans, R.N.J.; Fernandez, J.A.; Hilton, J.; Bettencourt, A de (eds.), (Elsevier, Amsterdam (NL), 1997) (Studies in environmental science, 68) p. 407

Dahlgaard, H.; Bergan, T.D.S.; Christensen, G.C., Technetium-99 and caesium-137 time series at the Norwegian coast monitored by the brown alga *Fucus Vesiculosus*. In: Radionuclides in the oceans. RADOC 96-97. Proceedings. Part 1: Inventories, behaviour and processes. RADOC 96-97. International symposium, Cherbourg-Octeville (FR), 7-11 Oct 1996. Germain, P.; Guary, J.C.; Guéguéniat, P.; Métivier, H. (eds.), (Les Editions de Physique, Les Ulis Cedex, 1997) (Radioprotection - Colloques, Vol. 32, C2) p. 353-358

Frid, W.; Nilsson, L.; Puska, E.K.; Højerup, F.; Miettinen, J.; Lindholm, I.; Sjövall, H., Severe accident recriticality analysis (SARA). In: FISA-97 symposium on EU research on severe accidents. Preprints. FISA-97 symposium, Luxembourg (LU), 17-19 Nov 1997. (European Commission, Bruxelles, 1997) p. 119-128

Gulin, S.B.; Aarkrog, A.; Polikarpov, G.G.; Nielsen, S.P.;

Egorov, V.N., Chronological study of  $^{137}\text{Cs}$  input to the Black Sea deep and shelf sediments. In: Radionuclides in the oceans. RADOX 96-97. Proceedings. Part 1: Inventories, behaviour and processes. RADOX 96-97. International symposium, Cherbourg-Octeville (FR), 7-11 Oct 1996. Germain, P.; Guary, J.C.; Guéguéniat, P.; Métivier, H. (eds.), (Les Editions de Physique, Les Ulis Cedex, 1997) (Radioprotection - Colloques, Vol. 32, C2) p. 257-262

Heydorn, K., Procedures for certification of BCR environmental reference materials. In: Harmonization of health related environmental measurements using nuclear and isotopic techniques. International symposium on harmonization of health related environmental measurements using nuclear and isotopic techniques, Hyderabad (IN), 4-7 Nov 1996. (International Atomic Energy Agency, Wien, 1997) p. 157-173

Horn, N.; Tønnesen, T.; Heydorn, K.; Damsgaard, E.; Kaitila, I., The distribution of tissue copper and other trace elements in occipital horn syndrome determined by neutron activation analysis. In: Trace and toxic elements in nutrition and health. Proceedings. 4. International conference on health and disease: Effects of essential and toxic trace elements, New Delhi (IN), 8-12 Feb 1993. Abdulla, M.; Vohora, S.B.; Athar, M. (eds.), (Wiley Eastern, New Delhi, 1995) p. 53-59

Lauritzen, B., Radiological consequences in Denmark following a severe reactor accident at the Ignalina nuclear power plant. In: Proceedings. Nordisk Selskap for Strålevern, det 11. ordinære møtet. Det 7. Nordiske radioøkologi seminar. Nordisk Selskap for Strålevern, 11. ordinære møte; 7. Nordiske radioøkologi seminar, 26-29 Aug 1996, Reykjavik (IS). Walderhaug, T.; Gudlaugsson, E.P. (eds.), (Nordic Radiation Protection Society, Reykjavik, 1997) p. 547-552

Nielsen, S.P., A comparison between predicted and observed levels of  $^{137}\text{Cs}$  and  $^{90}\text{Sr}$  in the Baltic Sea. In: Radionuclides in the oceans. RADOX 96-97. Proceedings. Part 1: Inventories, behaviour and processes. RADOX 96-97. International symposium, Cherbourg-Octeville (FR), 7-11 Oct 1996. Germain, P.; Guary, J.C.; Guéguéniat, P.; Métivier, H. (eds.), (Les Editions de Physique, Les Ulis Cedex, 1997) (Radioprotection - Colloques, Vol. 32, C2) p. 387-394

Nielsen, S.P., An intercomparison exercise on radionuclides in sediment samples. In: Proceedings. Nordisk Selskap for Strålevern, det 11. ordinære møtet. Det 7. Nordiske radioøkologi seminar. Nordisk Selskap for Strålevern, 11. ordinære møte; 7. Nordiske radioøkologi seminar, 26-29 Aug 1996, Reykjavik (IS). Walderhaug, T.; Gudlaugsson, E.P. (eds.), (Nordic Radiation Protection Society, Reykjavik, 1997) p. 105-112

Nielsen, S.P., A sensitivity analysis of a radiological assessment model for Arctic waters. In: Proceedings. Nordisk Selskap for Strålevern, det 11. ordinære møtet. Det 7. Nordiske radioøkologi seminar. Nordisk Selskap for Strålevern, 11. ordinære møte; 7. Nordiske radioøkologi seminar, 26-29 Aug 1996, Reykjavik (IS). Walderhaug, T.; Gudlaugsson, E.P. (eds.), (Nordic Radiation

Protection Society, Reykjavik, 1997) p. 417-424

Nielsen, S.P.; Øhlenschläger, M.; Karlberg, O., The radiological exposure of man from ingestion of Cs137 and Sr90 in seafood from the Baltic Sea. In: International symposium on ionising radiation. Proceedings. Vol. 2. International symposium on ionising radiation, Stockholm (SE), 20-24 May 1996. Amiro, B.; Avadhanula, R.; Johansson, G.; Larsson, C.-M.; Lüning, M. (eds.), (The Swedish Radiation Protection Institute, Stockholm, 1996) p. 608-617

Peltier, J.; Weihmann, G.H.; Arien, B.; Nonbøl, E.; Vanttola, T.; Zipper, R.; Heusener, G.; Piolanti, G.; Lopez-Jimenez, J.; Pettit, L.; Bassett, M.; Jehee, J.N.T., Joint safety research index (JSRI). In: FISA-97 symposium on EU research on severe accidents. Preprints. FISA-97 symposium, Luxembourg (LU), 17-19 Nov 1997. (European Commission, Bruxelles, 1997) p. 129-138

Rietz, B.; Heydorn, K.; Krarup-Hansen, A., The determination of platinum in tissue of different human organs by means of neutron activation analysis. In: Metal elements in environment, medicine and biology. Proceedings. 2. International symposium on metal elements in environment, medicine and biology, Timisoara (RO), 27-29 Oct 1996. Gârban, Z.; Dragan, P. (eds.), (Eurobit, Timisoara, 1997) p. 83-88

Rissanen, K.; Ikäheimonen, T.K.; Nielsen, S.P.; Matishov, D.G.; Matishov, G.G., Gammanuclide and plutonium concentrations in the White Sea. In: The third international conference on environmental radioactivity in the Arctic. Extended abstracts. Vol. 2. The AMAP international symposium on environmental pollution of the Arctic and 3. International conference on environmental radioactivity in the Arctic, Tromsø (NO), 1-5 Jun 1997. (Norwegian Radiation Protection Authority, Østerås, 1997) p. 222-224

Roed, J.; Andersson, K.G.; Lange, C., The fate and impact of radiocontaminants in urban areas. In: Health impacts of large releases of radionuclides. Symposium on health impacts of large releases of radionuclides, St. Petersburg (RU), 27-29 Feb 1996. Lake, J.V.; Bock, G.R.; Cardew, G. (eds.), (John Wiley & Sons, Chichester, 1997) (Ciba Foundation Symposium, 203) p. 109-119

Scott, E.M.; Gurbutt, P.; Harms, I.; Heling, R.; Kinehara, Y.; Nielsen, S.P.; Osvath, I.; Sazykina, T.; Wada, A.; Sjoebloom, K.L., Radiological impact assessment of dumped waste in the Kara Sea. In: The third international conference on environmental radioactivity in the Arctic. Extended abstracts. Vol. 2. The AMAP international symposium on environmental pollution of the Arctic and 3. International conference on environmental radioactivity in the Arctic, Tromsø (NO), 1-5 Jun 1997. (Norwegian Radiation Protection Authority, Østerås, 1997) p. 26-27

Strand, P.; Balonov, M.; Aarkrog, A.; Bewers, M.; Howard, B.; Salo, A.; Tsaturov, Y., Radioactive contamination in the Arctic. In: The third international conference on environmental radioactivity in the Arctic. Extended abstracts. Vol. 2. The AMAP international symposium on environmental pollution of the Arctic and 3.

International conference on environmental radioactivity in the Arctic, Tromsø (NO), 1-5 Jun 1997. (Norwegian Radiation Protection Authority, Østerås, 1997) p. 5-9

Trapeznikov, A.; Pozolotina, V.; Aarkrog, A.; Nielsen, S.P.; Yushkov, P.; Trapeznikova, V.; Chebotina, M.; Molchanova, I.; Karavaeva, E., Up-to-date radioecological studies of the Techa and Iset rivers (Ob-Irtysh basin) contaminated from 'MAYAK' plant. In: The third international conference on environmental radioactivity in the Arctic. Extended abstracts. Vol. 2. The AMAP international symposium on environmental pollution of the Arctic and 3. International conference on environmental radioactivity in the Arctic, Tromsø (NO), 1-5 Jun 1997. (Norwegian Radiation Protection Authority, Østerås, 1997) p. 233-234

Ølgaard, P.L., Potential risks of accidents with decommissioned nuclear submarines in the Arctic. In: The third international conference on environmental radioactivity in the Arctic. Extended abstracts. Vol. 2. The AMAP international symposium on environmental pollution of the Arctic and 3. International conference on environmental radioactivity in the Arctic, Tromsø (NO), 1-5 Jun 1997. (Norwegian Radiation Protection Authority, Østerås, 1997) p. 21-22

Ølgaard, P.L., Worldwide decommissioning of nuclear submarines: Plans and problems. In: Reducing wastes from decommissioned nuclear submarines in the Russian northwest: Political, technical, and economic aspects of international cooperation. NATO Advanced research workshop: Recycling, remediation, and restoration strategies for contaminated civilian and military sites in the Arctic far north, Kirkenes (NO), 24-28 Jun 1996. Kellogg, S.L.; Kirk, E.J. (eds.), (American Association for the Advancement of Science, Washington, DC, 1997) p. 41-44

Ølgaard, P.L., Worldwide decommissioning of nuclear submarines: Plans and problems. In: Decommissioning submarines in the Russian northwest. Assessing and eliminating risks. NATO advanced research workshop on recycling, remediation and restoration strategies for contaminated civilian and military sites in the Arctic far north, Kirkenes (NO), 24-28 Jun 1996. Kirk, E.J. (ed.), (Kluwer, Dordrecht, 1997) (NATO ASI series 2. Environment, vol. 32) p. 13-23

## **8.4 Publications for a broader readership**

Damkjær, A.; Andersen, C., Radon - en risiko der kan gøres noget ved. *Risønyt* (1997) (no.2) p. 8-9

Fynbo, P., Reaktoren løb løbsk. *Weekendavisen* (1997) (no.18 Jul) p. 6

Fynbo, P.B., 18 år og reaktoroperatør på Risø. *Risønyt* (1997) (no.4) p. 14-15



Højerup, C.F.; Majborn, B.; Ølgaard, P.L., Tredje årsrapport om kernekraftens internationale status. Risønyt (1997) (no.2) p. 15

Walmod-Larsen, O., Tvivl om svenskernes vilje til at begrænse CO<sub>2</sub>-udslip. Ingeniøren (1997) v. 23 (no.10) p. 10

Walmod-Larsen, O., Uden a-kraft ingen CO<sub>2</sub>-løsning. Ingeniøren (1997) v. 23 (no.14) p. 12

## 8.5 Unpublished lectures

Aarkrog, A., A retrospect of anthropogenic radioactivity in the global marine environment. RADOC. International symposium on radionuclides in the oceans, Norwich - Lowestoft (GB), 7-11 Apr 1997. Unpublished. Abstract available

Aarkrog, A., Radioaktive stoffer i naturen: Kilder, omsætning og virkninger. Foredrag i Dansk Naturhistorisk Forening, København (DK), 23 Oct 1997. Unpublished.

Andersen, C.E., Kilder til radon i boliger. Radon i boliger, Rønne (DK), 2 Dec 1997. Unpublished.

Brodersen, K., Experimental work and modelling carried out at Risø National Laboratory, Denmark, in the period March 1997 to September 1997. Group meeting on contribution to contract FI2W-CT96-0030: Barrier performance of cements and concretes in nuclear waste repositories, Aberdeen (GB), Sep 1997. Unpublished. Abstract available

Bøtter-Jensen L. "New Light on OSL". International Seminar on Luminescence Dating: Methods and Applications. Aarhus University, 5-7 May 1997. Paper submitted to Geol. Chronolog. (available).

Bøtter-Jensen L. "OSL techniques in retrospective dosimetry". Dose reconstruction for populations in areas contaminated by Chernobyl fallout. EU-NSF clustered contractors meeting, Kiev, Ukraine, 2-4 June 1997 (abstract available).

Bøtter-Jensen L. "The use of blue LEDs for stimulation of quartz". Luminescence and ESR Research Seminar, University of Durham, UK, 7-9 July 1997 (published in the Proceedings as an extended synopsis).

Bøtter-Jensen L. "OSL single aliquot techniques and methods". Seminar on luminescence dating, University of Hong Kong, Hong Kong, 7 November 1997 (unpublished).

Bøtter-Jensen L. "OSL techniques for dating feldspars, quartz and porcelain". Luminescence dating seminar, Shanghai Museum, Shanghai, China, 11 November 1997 (unpublished)

Bøtter-Jensen L. "Recent developments of OSL techniques for dating and retrospective dosimetry". Invited talk given at a luminescence dating seminar at the University of Peking, Beijing, China, 14 November 1997 (unpublished, abstract available).

Bøtter-Jensen, L., Retrospective radiation dosimetry using optically stimulated luminescence on natural materials and ceramic for assessing accident doses. Health Physics Society annual meeting, San Antonio, TX (US), 29 Jun - 3 Jul 1997.  
Unpublished. Abstract available

Dahlgaard, H., Radioaktive stoffer i norske farvande: langdistance transport med havstrømme. Radioaktiv forurensning i marine miljøer seminar, Bergen (NO), 15-16 Apr 1997.  
Unpublished.

Fogh, C.L., Scavenging of atmospheric particles by precipitation as a function of particle size. NOSA 97. Annual Nordic aerosol symposium, Göteborg (SE), 23-24 Oct 1997.  
Unpublished. Abstract available

Fogh, C.L., Deposition of particles to rooms and their inhabitants. GSF - Forschungszentrum für Umwelt und Gesundheit, Institut für Strahlenschutz. Seminar, Neuherberg (DE), 6 Mar 1997.  
Unpublished.

Fynbo, P.B., STORM-projektet. En oversigt. Videnberedningsseminar, Risø (DK), 13 Nov 1997.  
Unpublished. Abstract available

Fynbo, P.B.; Kuhn, H., Calibration of radiation system. STORM meeting, Ispra (IT), 30 Jun - 1 Jul 1997.  
Unpublished. Abstract available

Heydorn, K., Distribution of platinum in patients treated with cisplatin determined by radiochemical neutron activation analysis. Conference on methods and applications of radioanalytical chemistry, Kailua-Kona, HI (US), 9 Apr 1997.  
Unpublished.

Heydorn, K., Quality assurance by statistical control. IAEA research co-ordination meeting, Wien (AT), 12 May 1997.  
Unpublished.

Heydorn, K., Modern trends in contemporary nuclear research management at Risø National Laboratory. Institut de Fizica Horia Hulubei, Bucharest (RO), 28 May 1997.  
Unpublished.

Højerup, C.F., Recriticality studies at Risø. Nordic reactor physics meeting, Kjeller (NO), 13-14 Mar 1997.  
Unpublished. Abstract available

Højerup, F., Rekritikalitet efter reaktoruheld.

Videnberedskabsseminaret, Risø (DK), 29 Apr 1997.  
Unpublished. Abstract available

Højerup, F.; Miettinen, J.; Nilsson, L.; Puska, E.K.; Sjövall, H.; Anttila, M.; Lindholm, I.; Frid, W., On recriticality during reflooding of a degraded boiling water reactor core. Co-operative Severe Accident Research Programme (CSARP) meeting, Bethesda, MD (US), 5-8 May 1997.  
Unpublished.

Jacobsen, U., Isotoplaboratoriets virksomhed. Møde i Dansk Kerneteknisk Selskab, Risø (DK), 3 Jun 1997.  
Unpublished.

Krarp-Hansen, A.; Fugleholm, K.; Schmalbruch, H.; Meidal Pedersen, P.; Rietz, B.; Heydorn, K.; Krarp, C.; Rørth, M., Animal models of Cisplatin toxicity. 25. Annual symposium of the Scandinavian Society for Laboratory Animal Science. The implication of welfare in laboratory animal science, Elsinore (DK), 22-24 May 1997.  
Unpublished. Abstract available

Metz, H.P., Validation of the fluid dynamics code DYNOS against Frigg and Desire datas. Nordic reactor physics meeting, Kjeller (NO), 13-14 Mar 1997.  
Unpublished.

Metz, P., DYNOS. A generalised fluid dynamics code for nuclear reactor systems. Videnberedskabsseminaret, Risø (DK), 29 Apr 1997.  
Unpublished. Abstract available

Nielsen, S.P., Radioaktiv forurening i havene - hvad betyder det for mennesker?. Dansk Kerneteknisk Selskab - julemøde, København (DK), 4 Dec 1997.  
Unpublished. Abstract available

Nielsen, S.P.; Dahlgard, H., Radionuclides in sediment cores from Thule, Greenland, 1991. NKS/EKO-1 seminar, Helsinki (FI), 2-3 Apr 1997.  
Unpublished. Abstract available

Nonbøl, E., Sizewell B nuclear power plant. Videnberedskabsseminaret, Risø (DK), 13 Nov 1997.  
Unpublished. Abstract available

Nonbøl, E., Mobile reactors. NKS/RAK seminar, Stockholm (SE), 25-27 Nov 1997.  
Unpublished. Abstract available

Rietz, B.; Stürup, S.; Behrens, A.; Bibak, A.; Gundersen, V.; Heydorn, K., Neutron activation analysis for quality assurance of trace element analysis of vegetables by ICP-MS. In: Trace elements in human health and disease. Abstracts. 6. Nordic symposium on trace elements in human health and disease, Roskilde (DK), 29 Jun - 3 Jul 1997. (Roskilde University, Roskilde, 1997) p. 70

Roed, J.; Lange, C.; Andersson, K.G., Decontamination in a Russian settlement. In: Proceedings. Nordisk Selskap for Strålevern, det 11. ordinære møtet. Det 7. Nordiske radioøkologi seminar. Nordisk Selskap for Strålevern, 11. ordinære møte; 7. Nordiske radioøkologi seminar, 26-29 Aug 1996, Reykjavik (IS). Walderhaug, T.; Gudlaugsson, E.P. (eds.), (Nordic Radiation Protection Society, Reykjavik, 1997) p. 477

Thomsen, K.L., Den sene fase af nedsmeltlingsforløbet i reaktortanken under et alvorligt uheld (RAK-2.1). Videnberedskabsseminaret, Risø (DK), 13 Nov 1997.  
Unpublished. Abstract available

Trinkler, L.; Christensen, P.; Larsen, N.A.; Berzina, B., Thermoluminescence properties of AlN ceramics. 3. International symposium on luminescent detectors and transformers of ionizing radiation, LUMDETR'97, Ustron (PL), Oct 1997.  
Unpublished. Abstract available

Ølgaard, P.L., Questions related to the risks associated with non-defueled nuclear submarines. Plenary meeting of the NATO/NACC/CCMS pilot study of cross-border environmental problems emanating from military installations and activities, Warsaw (PL), 16-18 Jun 1997.  
Unpublished. Abstract available

Ølgaard, P.L., Review of available information on decommissioned nuclear submarines and spent nuclear fuel in Russia. Meeting of the NATO/NACC/CCMS pilot study on cross-border environmental problems emanating from defence-related installations and activities, Greenwich (GB), 3-5 Mar 1997.  
Unpublished. Abstract available

Ølgaard, P.L., Skal vi frygte kernekraften?. Østerbro Rotary Klub, Hellerup (DK), 8 Apr 1997.  
Unpublished. Abstract available

Ølgaard, P.L., Kritikalitetsuheld i forbindelse med ubåde. Videnberedskabsseminaret, Risø (DK), 29 Apr 1997.  
Unpublished. Abstract available

Ølgaard, P.L., Er alle tanker om fissionsenergi ude? Bliver fusionsenergien til noget?. Energiseminar 1997: Fremtidens energiformer. AUC, Aalborg (DK), 12 Aug 1997.  
Unpublished.

Ølgaard, P.L., Nuclear submarine decommissioning: Plans, problems and risks. 22. Session of the international seminars on planetary emergencies, Erice, Sicily (IT), 19-24 Aug 1997.  
Unpublished. Abstract available

Ølgaard, P.L., Decay heat from submarine reactors. Meeting of the NATO/NACC/CCMS pilot study on cross-border environmental problems emanating from defence-related installations and activities,

Cadarache (FR), 14-15 Oct 1997.  
Unpublished. Abstract available

Ølgaard, P.L., Decommissioning af forsøgsreaktorer.  
Videnberedskabsseminaret, Risø (DK), 13 Nov 1997.  
Unpublished. Abstract available

Ølgaard, P.L., Nuclear risks of decommissioned nuclear submarines  
with non-defueled reactors. Advanced research workshop on analysis of  
risks associated with nuclear submarine decommissioning, dismantling  
and disposal, Moscow (RU), 24-26 Nov 1997.  
Unpublished. Abstract available

## 8.6 Internal reports

Aarkrog, A.; Christensen, P.; Clausen, J.; Hansen, H.; Nielsen,  
S.P., Radioactivity in the Risø District July-December 1996.  
(Radioaktiviteten i Risø-området juli-december  
1996). Risø-I-1152(EN) (1997) 20 p.

Aarkrog, A.; Christensen, P.; Clausen, J.; Hansen, H.; Nielsen,  
S.P., Radioactivity in the Risø District January-June 1997.  
(Radioaktiviteten i Risø-området januar-juni  
1997). Risø-I-1197(EN) (1997) 24 p.

Annual report 1996. Isotope Division. Risø-Dok-543 (1997) vp.

Borg, J.; Helt-Hansen, J., EGS4 Monte Carlo calculations of energy  
deposition in silicon detectors of a triple telescope beta  
spectrometer from exposure to electrons and  
photons. Risø-I-1209(EN) (1997) 209 p.

Fynbo, P.B., STORM-projektet. Statusrapport  
1996. Risø-I-1116(DA) (1997) 11 p.

Fynbo, P.B., Stråledoser fra DR1's  
øvelser. Risø-I-1187(DA) (1997) 13 p.

Heydorn, K.; Jacobsen, U.; Jørgensen, J.C.; Hegaard, N.;  
Andresen, K.; Damsgaard, E.; Rietz, B., Isotoplaboratoriet.  
Periodisk rapport 4, 1996. Risø-I-1125(DA) (1997) 9 p.

Heydorn, K.; Jacobsen, U.; Jørgensen, J.C.; Hegaard, N.;  
Andresen, K.; Damsgaard, E.; Rietz, B., Isotoplaboratoriet.  
Periodisk rapport 1, 1997. Risø-I-1160(DA) (1997) 8 p.

Heydorn, K.; Jacobsen, U.; Jørgensen, J.C.; Hegaard, N.;  
Andresen, K.; Damsgaard, E.; Rietz, B., Isotoplaboratoriet.  
Periodisk rapport 2, 1997. Risø-I-1181(DA) (1997) 8 p.

Heydorn, K.; Jacobsen, U.; Jørgensen, J.C.; Hegaard, N.;  
Andresen, K.; Damsgaard, E.; Rietz, B., Isotoplaboratoriet.  
Periodisk rapport 3, 1997. Risø-I-1213(DA) (1997) 8 p.

Højerup, C.F., Use of the steady-state neutron flux code, TWODIM, for dynamic calculations, a new approach. Risø-I-1138(EN) (1997) 15 p.

Højerup, C.F., The RECRIT programme and some results from running it. Risø-I-1196(EN) (1997) 30 p.

Højerup, C.F.; Nonbøl, E., Monte Carlo calculations of neutron doses to components of the Forsmark 1 BWR. Risø-I-1155(EN) (1997) 67 p.

Jensen, S.E. (ed.), Reaktor periode nr. 456. Driftsrapport. Tidsrum: 15 december 1996 til 12 januar 1997. Risø-I-1120(DA) (1997) 13 p.

Jensen, S.E. (ed.), Reaktor periode nr. 461. Driftsrapport. Tidsrum: 4 maj 1997 til 8 juni 1997. Risø-I-1169(DA) (1997) 13 p.

Ladekarl Thomsen, K., Status of a literature study on LWR core meltdown and in-vessel coolability. Risø-I-1113(EN) (1997) 40 p.

Ladekarl Thomsen, K., Literature study on the TMI-2 accident evaluation and vessel investigation projects. Risø-I-1146(EN) (1997) 64 p.

Lauritzen, B.; Bäverstam, U., Dose rate measurements and action levels in the event of a nuclear accident: Variational analysis. Risø-I-1121(EN) (1997) 25 p.

Lippert, J., Check and calibration of a PMS-E station. Risø-I-1200(EN) (1997) 14 p.

Nielsen, F., Beredskabsstyrelsens permanente målesystem. Driftsrapport for 1996. Risø-I-1099(DA) (1997) 33 p.

Nielsen, K.H. (ed.), Reaktor periode nr. 457. Driftsrapport. Tidsrum: 12 januar 1997 til 9 februar 1997. Risø-I-1133(DA) (1997) 12 p.

Nielsen, K.H. (ed.), Reaktor periode nr. 462. Driftsrapport. Tidsrum: 8 juni 1997 til 6 juli 1997. Risø-I-1174(DA) (1997) 13 p.

Nonbøl, E., Beregning af neutronfluxen i den vandrette forsøgsrig 7T2 i DR3. Risø-I-1091(DA) (1997) 33 p.

Nonbøl, E., NKS database of nuclear reactors neighbouring the Nordic countries. Progress report 1996. Risø-I-1114(EN) (1997) 23 p.

Qvist, J. (ed.), Reaktor periode nr. 454. Driftsrapport. Tidsrum: 15 september 1996 til 17 november 1996. Risø-I-1097(DA) (1997) 14 p.

Qvist, J. (ed.), Reaktor periode nr. 459. Driftsrapport. Tidsrum: 9 marts 1997 til 6 april 1997. Risø-I-1139(DA) (1997) 13 p.

Qvist, J. (ed.), Reaktor periode nr. 464. Driftsrapport. Tidsrum: 3. august 1997 til 31. august 1997. Risø-I-1194(DA) (1997) 13 p.

Sørensen, J.R. (ed.), Reaktor periode nr. 453. Driftsrapport.  
Tidsrum: 18 august 1996 til 15 september  
1996. Risø-I-1096(DA) (1997) 13 p.

Sørensen, J.R. (ed.), Reaktor periode nr. 458. Driftsrapport.  
Tidsrum: 9 februar 1997 til 9 marts  
1997. Risø-I-1137(DA) (1997) 13 p.

Sørensen, J.R. (ed.), Reaktor periode nr. 463. Driftsrapport.  
Tidsrum: 6. juli 1997 til 3. august  
1997. Risø-I-1182(DA) (1997) 13 p.

Winstrøm, P.R. (ed.), Reaktor periode nr. 450. Driftsrapport.  
Tidsrum: 17 november 1996 til 15 december  
1996. Risø-I-1103(DA) (1997) 13 p.

Winstrøm, P.R. (ed.), Reaktor periode nr. 460. Driftsrapport.  
Tidsrum: 6 april 1997 til 4 maj 1997. Risø-I-1162(DA) (1997) 13 p.

Winstrøm, P.R. (ed.), Reaktor periode nr. 465. Driftsrapport.  
Tidsrum: 31. august 1997 til 28. september  
1997. Risø-I-1195(DA) (1997) 13 p.

Ølgaard, P.L., Review of available information on decommissioned  
nuclear submarines and spent nuclear fuel in  
Russia. Risø-I-1124(EN) (1997) 14 p.

Ølgaard, P.L., Decommissioning of research reactors. Experience from  
the DR2. Risø-I-1166(EN) (1997) 54 p.

Ølgaard, P.L., Nuclear submarine decommissioning: Plans, problems,  
and risks. Risø-I-1177(EN) (1997) 10 p.

Ølgaard, P.L., Decay heat from submarine  
reactors. Risø-I-1190(EN) (1997) 10 p.

Ølgaard, P.L., Nuclear risks of decommissioned nuclear submarines  
with non-defueled reactors. Risø-I-1207(EN) (1997) 10 p.

# 9 Education

## 9.1 Ph.D. theses

Hoff, Ayoe G., 1997: Radon Transport in Fractured Soil: Laboratory Experiments and Modelling. Risø National Laboratory and University of Copenhagen. Risø-R-975 (EN) 150 p.

Grosell, Martin, 1997: Acclimation to Cu by freshwater teleost fish; Cu uptake, metabolism and elimination during exposure to elevated ambient Cu concentrations. Risø National Laboratory and University of Copenhagen.

## 9.2 M.Sc. theses

Helt-Hansen, Jakob, 1997: Beta-spektroskopi med silicium halvlederdetektorer. Risø National Laboratory and University of Copenhagen.

## 9.3 External teaching

Fynbo, Peter. Lectures in Reactor Physics at the Technical University of Denmark.

Lauritzen, Bent. Lectures in Health Physics at the Technical University of Denmark.

Nielsen, Sven P. Lectures in Radioecology at the Technical University of Denmark.

Nonbøl, Erik. Lectures in Nuclear Engineering at the Technical University of Denmark.

Roed, Jørn. Lectures in Radiation Instruments at the Technical University of Denmark.

## 9.4 External examiners

Damkjær, A. Examiner in physics at the University of Copenhagen and at the Technical University of Denmark.

Fynbo, P.B. Examiner in physics at the University of Odense.

Heydorn, K. Examiner at Ph.D. thesis, University of Pune, India.

Højerup, C.F. Examiner in Reactor Physics at the Technical University of Denmark.

Jacobsen, U. Examiner in Isotope Techniques at the Technical University of Denmark.



# 10 Committee memberships

## 10.1 National

The advisory committee on protection measures in the case of accidents in nuclear facilities (§ 9 stk 2)

C.F. Højerup and B. Majborn

(E. Nonbøl and O. Walmod-Larsen, substitutes)

The coordination committee of the Emergency Management Agency and Risø National Laboratory

A. Damkjær and B. Majborn

The coordination committee for nuclear safety in Central and Eastern Europe (Ministry of Foreign Affairs)

B. Majborn

The advisory coordination committee for research in environmental medicine (Ministry of Health)

B. Majborn

The Board of the Danish Nuclear Society

B. Majborn and M. Bagger Hansen

Danish National Council for Oceanology

A. Aarkrog

The Academy of the Technical Sciences

K. Heydorn

The DK-BCR committee

K. Heydorn

The Contact Committee for Chemometry. The Society of Danish Engineers

K. Heydorn

## 10.2 International

### European Union

Consultative Committee for the Specific Programme on Nuclear Fission Safety 1994-1998

B. Majborn

European Community Standards, Measurements and Testing

K. Heydorn

Technical Experts on Radiation Protection Dosimetry

P. Christensen

Technical Experts on Environmental Radiation Monitoring

L. Bøtter-Jensen

EURADOS working group 2. Skin Dosimetry  
P. Christensen

EURADOS working group 12. Environmental Radiation Monitoring  
L. Bøtter-Jensen

Articles 35 and 36 of the European Treaty (Environmental Monitoring)  
S.P. Nielsen

Article 37 Group of Experts  
O. Walmod-Larsen

Expert Group of Transfrontier Emergency Planning  
O. Walmod-Larsen

National Correspondents on Assistance and Emergency Planning in the Event  
of a Nuclear Accident or Radiological Emergency  
F. Nielsen

Working Party on Criteria for Recycling Materials from the Dismantling of  
Nuclear Installations  
M.S. Carugati

ACPM for the Community Plan of Action in the Field of Radioactive Waste  
K. Brodersen

International Technical Division on Reference Materials  
K. Heydorn

Scientific Committee of STORM (Simplified Test on Resuspension  
Mechanisms)  
P.B. Fynbo

Group for Nuclear Safety Research Index, NSRI  
E. Nonbøl

### **OECD/NEA**

Nuclear Science Committee  
C.F. Højerup

NEA Data Bank Executive Group  
C.F. Højerup

CSNI (NEA) Committee on the Safety of Nuclear Installations  
P.B. Fynbo

Principal Working Group 4, PWG 4  
P.B. Fynbo

### **Editorial Advisory Boards**

Journal of Environmental Radioactivity  
A. Aarkrog

Radiation Measurements

L. Bøtter-Jensen

Radiation Protection Dosimetry

L. Bøtter-Jensen

Journal of Radioanalytical and Nuclear Chemistry

K. Heydorn

Revista Nucleotecnica

K. Heydorn

Analytical Letters

B. Rietz

Nuclear Europe Worldscan

K. Hjerrild Nielsen

### **Other Committees**

The Board of the Nordic Nuclear Safety Research Programme, NKS

B. Majborn

NKS Reference Group for Radioecology and Emergency Preparedness

A. Aarkrog

NKS Reference Group for Radioactive Waste

K. Brodersen

The Board of the Nordic Society for Radiation Protection

A. Aarkrog (President) and A. Damkjær (Executive secretary)

Baltic Marine Environment Protection Commission Helsinki Commission  
(HELCOM)

S. P. Nielsen

Group of Experts on Monitoring of Radioactive Substances in the Baltic Sea  
(MORS)

Henning Dahlgaard

International Committee on Radionuclide Metrology

S. P. Nielsen

International Solid State Dosimetry Organization

L. Bøtter-Jensen

Standing Committee for the International Solid State Dosimetry Conferences

L. Bøtter-Jensen

International Technical Division on Reference Materials

K. Heydorn

MTAA International Committee

K. Heydorn

European Atomic Energy Society (EAES) Working Group  
B. Majborn

European Atomic Energy Society (EAES). Research Reactor Operators Group  
H. Floto

Dido-Pluto Operators Meetings  
H. Floto

# 11 Personnel

## Head of department

Benny Majborn

## 11.1 Scientists and engineers

### Radiation protection

Anders Damkjær (head of programme)

Claus Erik Andersen

Debabrata Banerjee (post doc, from 24 June)

Jette Borg (post doc, until 30 April)

Lars Bøtter-Jensen

Poul Christensen

Bent Lauritzen

Jørgen Lippert

Flemming Nielsen

Ole Walmod-Larsen (until 31 July)

### Radioecology

Asker Aarkrog (head of programme)

Kasper Andersson

Qiangjiang Chen

Henning Dahlgård

Christian Lange Fogh

Heinz Hansen

Sven P. Nielsen

Jørn Roed

### Reactor safety

Povl L. Ølgaard (head of programme)

P.E. Becher

Peter Bille Fynbo

C.F. Højerup

Erik Nonbøl

Knud Ladekarl Thomsen

### Isotope Laboratory

Kaj Heydorn (head of laboratory)

Kirsten S. Andresen

Else Damsgaard

Niels Hegaard

Ulf Jacobsen

Jesper C. Jørgensen

Bernd Rietz

### Research reactor DR3

Heinz Floto (reactor manager)

Mogens Bagger Hansen (deputy reactor manager)

Niels Ole Birkelund

Søren Erik Jensen

Kirsten Hjerrild Nielsen  
Jens Svane Qvist  
John A. Sørensen  
Poul Winstrøm

#### **Waste Management Plant**

Knud Brodersen (head of waste management plant)  
Massimo Steen Carugati

## **11.2 Technical staff**

#### **Radiation protection**

Birthe Berg  
Per Brøns  
Henrik E. Christiansen  
Lissi Sture Hansen  
Jørgen Jakobsen  
Nina Jensen  
Finn Jørgensen  
Finn Pedersen  
Lis Sørensen  
Finn Willumsen

#### **Radioecology**

Gunnar Bitsch  
Oda Brandstrup  
Pearl Baade-Pedersen  
Tove Christensen  
Jytte Clausen  
Elly Hansen  
Henrik Hougaard Pedersen  
Vibeke Jørgensen  
Alice Kjølhede  
Karen Mandrup Jensen  
Svend K. Olsen  
Henrik Prip

#### **Isotope Laboratory**

Steen Bidstrup  
Jørgen Hanefeld-Møller  
Trine Hansen  
Jette Iversen  
Michael Jacobsen  
Gert Ragner Jensen  
Svend E. Kerchhoff  
Birgitte Larsen  
Leif Laursen  
Kirsten M. Madsen  
Mads Wille

#### **Research reactor DR3**

Axel B. Andersen  
Bent Steen Andersen  
Stig Andersen

Søren Holm Bang  
Heino Bentzen  
Jørgen Christensen  
Knud E. Christiansen  
Kari Fernstrøm  
Henning Frederiksen  
Bende Christian Hansen  
Benny Kurt Hansen  
Wagn Søndergaard Hansen  
Thomas Hauschildt  
Kim Peter Hejlund  
Poul Aage Jacobsen  
Børge Jensen  
Henning Jørgensen  
Benny Carl Kjølhede  
John Larsen  
Niels Larsen  
Tim Granskov Madsen  
Børge Nielsen  
Charlotte A. Nielsen  
Freddy Nielsen  
Ove Lilholm Nielsen  
Peter Nielsen  
Carsten Nikolajsen  
Jesper Nørgaard  
Erling Aarup Pedersen  
Per Pedersen  
Thomas D. Petersen  
Bo Ransfort  
Henning Rask  
Søren Roed  
Finn Rudolfsen  
Leif Rødskov  
Michael Thomsen  
Claus Thorsen  
Arne West  
Arne Flemming Würtz  
Ole H. Andersen  
Bent Christensen  
Flemming Frederiksen  
John Gade  
Finn Grandahl Jacobsen  
Sten Brian Jensen  
Thorkild Johansen  
Jacob M. Mortensen  
Morten Lillevang Nielsen  
Palle Bøgelund Nielsen  
Søren Ole Nielsen

**Waste Management Plant**

Birthe Andersen  
Winnie Andersen  
Mogens Christiansen  
Birthe Hansen  
Signe Hansen

Ole Sjølling Hansen  
Kurt Jensen  
Peter Nielsen  
Palle Olsson  
Jesper Bohn Rasmussen  
Nina Thomsen  
Bent Villumsen (until 30 June)  
Ruth Aagesen

### **11.3 Office staff**

Lene Birch  
Inge Blyitgen  
Anni Lambæk Hansen  
Berit Kornerup  
Merete Larsen  
Margit Nielsen  
Lis Rasmussen

### **11.4 Ph.D. students**

Jakob Helt Hansen (from 1 March)  
Ayoe G. Hoff (until 28 February)  
Niels A. Larsen (until 28 February)  
Hans Peter Metz

### **11.5 Apprentices**

Per Hansen

### **11.6 Guest scientists**

Alexander Bougai, Institute of Semiconductor Physics, Kiev, Ukraine  
Geoff A.T. Duller, University College of Wales, UK  
Kendra M. Foltz, University of Illinois, USA  
Christer Högstrand, University of Kentucky, USA  
Högne Jungner, University of Helsinki, Finland  
Helena Karakaeva, Inst. of Animal and Plant Ecology, Russia  
Steve W. M. McKeever, Oklahoma State University, USA  
Galina Lazorenko, Inst. of Animal and Plant Ecology, Russia  
Inna Molchanova, Inst. of Animal and Plant Ecology, Russia  
Eddie J. Rhodes, Univ. of London, Royal Holloway and Bedford College, UK  
Vitali V. Rymkevich, Minsk, IPEP  
Irina Shtangeeva, University of St. Petersburg, Russia  
Aleander Trapeznikov, Inst. of Animal and Plant Ecology, Russia  
Vera Trapeznikov, Inst. of Animal and Plant Ecology, Russia  
Ann Wintle, University of Wales, Aberystwyth, UK  
Gao Zhangong, China Institute for Radiation Protection, China



Title and authors

Nuclear Safety Research and Facilities Department  
Annual Report 1997

Edited by B. Majborn, A. Aarkrog, K. Brodersen, A. Damkjær, H. Floto, K. Heydorn, S.P. Nielsen, E. Nonbøl and P.L. Ølgaard

ISBN	ISSN		
87-550-2344-4	0106-2840 1396-3619		
Department or group	Date		
Nuclear Safety Research and Facilities	April 1998		
Groups own reg. number(s)	Project/contract No(s)		
Pages	Tables	Illustrations	References
88	11	39	

Abstract (Max. 2000 characters)

The report presents a summary of the work of the Nuclear Safety Research and Facilities Department in 1997. The department's research and development activities were organized in four research programmes: Reactor Safety, Radiation Protection, Radioecology, and Radioanalytical Chemistry. The nuclear facilities operated by the department include the research reactor DR3, the Isotope Laboratory, the Waste Treatment Plant, and the educational reactor DR1. Lists of staff and publications are included together with a summary of the staff's participation in national and international committees.

Descriptors INIS/EDB

INTERNATIONAL COOPERATION; PROGRESS REPORT; RADIATION PROTECTION; RADIOACTIVE WASTE MANAGEMENT; RADIOCHEMISTRY; RADIOECOLOGY; REACTOR PHYSICS; REACTOR OPERATION; REACTOR TECHNOLOGY; RESEARCH PROGRAMS; RISØE NATIONAL LABORATORY

Available on request from Information Service Department, Risø National Laboratory,  
(Afdelingen for Informationsservice, Forskningscenter Risø), P.O.Box 49, DK-4000 Roskilde, Denmark.  
Telephone +45 46 77 40 04, Telefax +45 46 77 40 13