



## **Power system models - A description of power markets and outline of market modelling in Wilmar**

**Meibom, Peter; Morthorst, Poul Erik; Nielsen, Lars Henrik; Weber, C.; Sander, K.; Swider, D.; Ravn, H.**

*Publication date:*  
2004

*Document Version*  
Publisher's PDF, also known as Version of record

[Link back to DTU Orbit](#)

*Citation (APA):*  
Meibom, P., Morthorst, P. E., Nielsen, L. H., Weber, C., Sander, K., Swider, D., & Ravn, H. (2004). Power system models - A description of power markets and outline of market modelling in Wilmar. (Denmark. Forskningscenter Risoe. Risoe-R; No. 1441(EN)).

## **DTU Library** Technical Information Center of Denmark

---

### **General rights**

Copyright and moral rights for the publications made accessible in the public portal are retained by the authors and/or other copyright owners and it is a condition of accessing publications that users recognise and abide by the legal requirements associated with these rights.

- Users may download and print one copy of any publication from the public portal for the purpose of private study or research.
- You may not further distribute the material or use it for any profit-making activity or commercial gain
- You may freely distribute the URL identifying the publication in the public portal

If you believe that this document breaches copyright please contact us providing details, and we will remove access to the work immediately and investigate your claim.

# **Power System Models**

A Description of Power Markets and  
Outline of Market Modelling in Wilmar

## **Deliverable 3.2**

Peter Meibom, Risø National Laboratory  
Poul Erik Morthorst, Risø National Laboratory  
Lars Henrik Nielsen, Risø National Laboratory  
Christoph Weber, IER, University of Stuttgart  
Kai Sander, IER, University of Stuttgart  
Derk Swider, IER, University of Stuttgart  
Hans Ravn, Technical University of Denmark

**December 2003**

## **Abstract**

The aim of the Wilmar project is to investigate technical and economical problems related to large-scale deployment of renewable sources and to develop a modelling tool that can handle system simulations for a larger geographical region with an International power exchange. Wilmar is an abbreviation of “*Wind Power Integration in Liberalised Electricity Markets*”. The project was started in 2002 and is funded by the EU’s 5<sup>th</sup> Research programme on energy and environment. Risø National Laboratory is co-ordinator of the project and partners include SINTEF, Kungliga Tekniska Högskola, University of Stuttgart, VTT, Nord Pool Consult, Technical University of Denmark, ELSAM A/S and Elkraft-System A/S.

This report is Deliverable 3.2 of the project. The report describes the power markets in the Nordic countries and Germany, together with the market models to be implemented in the Wilmar Planning modelling tool developed in the project. The starting points for the design of the power market models are the functioning of the electricity markets in Germany and in the Nordic countries, Denmark, Finland, Norway and Sweden. These two power markets are thoroughly described in the first part of the report. A qualitative description of the power market models used in Wilmar is given in the second part, though the mathematical presentations of the models are left out of this report and will be treated in a later publication from the project.

## **WILMAR - WIND POWER INTEGRATION IN A LIBERALISED ELECTRICITY MARKET**

**CONTRACT No.: ENK5-CT-2002-00663**

**DELIVERABLE 3.2**

**PROJECT CO-ORDINATOR: Risø National Laboratory**

**ISBN 87-550-3288-5(Internet)**

**ISSN 0106-2840**

# Contents

## **1 The Wilmar Project 6**

- 1.1 Introduction 6
- 1.2 Intermittence and Power Systems Integration 7
- 1.3 Objectives of Wilmar 8
- 1.4 The Aim of this Report 8

## **2 The Nordic Power Market 10**

- 2.1 Markets of Importance to Power Trade in the Nordic Area 10
- 2.2 The Nord Pool Spot Market 13
  - The Bidding Procedure 13
  - Pricing in Nord Pool 14
  - Case Study for Western Denmark 16
- 2.3 The Nordic Regulating and Balancing Market 19
  - The Functioning of the Regulating and Balancing Markets 19
  - Case Study: Wind Power and the Balancing Market 21

## **3 The German Electricity Market 25**

- 3.1 Introduction 25
- 3.2 The EEX Spot Market 25
  - Closed Auction 26
  - Continuous Trading 28
  - Analysis of Prices and Volume 29
- 3.3 The German Forward and Futures Markets 30
  - Analysis of Prices and Volume 33
- 3.4 The German Regulating Power Markets 33
  - General Structure of the RPM in Germany 34
  - Analysis of Prices and Volume 37

## **4 Models 41**

- 4.1 Modelling Power Markets and Electricity Prices 41
  - Fundamental Models 42
  - Finance and Econometric Models 44
  - Modelling Competition in the Electricity Industry 45
    - An Integrated Modelling Approach 46
- 4.2 General Modelling Assumptions 47
  - Number of Markets for Physical Delivery of Electricity 47
  - Other Markets Represented in the Model 47
  - Short-Term Marginal Pricing 48
- 4.3 Modelling Framework 48
- 4.4 Long-term Model 50
  - Present Implementation of the One Storage Program (the HYSP Module) 51
  - Limitations in the Present Implementation 52
  - Test Runs and Observations 52
  - Integration of the Long-Term Model and the Joint Market Model 53
- 4.5 Joint Market Model 53
  - Functionality 53
  - Geography 54
  - Table 8 shows the imagined geographical resolution of the data. 55
  - Time 56
  - Decision Structure 56
  - Bid Strategy of Consumers and Producers 59

**5 Concluding remarks 61**

**6 References 63**

# Preface

*This report is Deliverable 3.2 of the EU project “Wind Power Integration in Liberalised Electricity Markets” (WILMAR). The report describes the power markets in the Nordic countries and Germany, together with the market model suggested implementing in the Wilmar Planning modelling tool developed in the project. The aim of the Wilmar project is to investigate the technical and economical problems related to large-scale deployment of renewable sources and to develop a modelling tool that can handle system simulations for a larger geographical region with an International power exchange. When finalised, the model will be available to actors within the power sector, including power system operators, energy authorities, power producers and other potential investors within this field.*

*The report is not intended to give a full documentation of the Planning model, but concentrate on describing the ideas and assumptions behind the representation of the market place in the Planning model. A later Deliverable (D6.2) will give a full documentation of the Planning model.*

*The report is edited by Poul Erik Morthorst, Risoe, based on contributions from Risoe National Laboratory, IER University of Stuttgart and the Technical University of Denmark.*

# 1 The Wilmar Project

## 1.1 Introduction

In 2002, the European Union ratified the Kyoto protocol and thus the member states and the EU have committed themselves to a common greenhouse gas (GHG) reduction of 8% by the years 2008-12 compared with 1990. By now, both the member countries and the EU already have or are in the process of adopting policies of GHG-limitations in accordance with the agreed burden sharing in EU and the development of renewable energy resources is expected to play an important role in the implementation of these GHG-targets.

In the White Paper on a strategy for the development of renewable energy, the EU Commission has launched a goal of covering 12% of the European Union's gross inland energy consumption by the year 2010 by renewable sources, i.e., mainly by biomass, hydro power, wind energy and solar energy. Next to biomass, wind energy is foreseen to be the main contributor with regard to future importance (European Commission, 1997). Furthermore, the European Commission has agreed on a directive on the promotion of renewable energy technologies (European Commission, 2000), including a proposal on the share of renewables in the individual member states in 2010, based on the percentage of each country's consumption of electricity. Although not binding, these targets are by now accepted by the EU member states. Thus, the directive signals the need to include renewable energy technologies as one of the serious options in achieving the targets for GHG-reductions.

In parallel with the implementation of the Kyoto GHG –commitments, a number of countries are liberalising their electricity industry. The cornerstone in liberalisation is the opening of the electricity markets for trade, both within the country and among countries. To generate efficient competition, unbundling of the power industry might be necessary: to split existing companies into independent ones for production, transmission and distribution of electricity. Finally, in order to handle the dispatch of electricity, an independent systems operator is needed, and establishing a power exchange might facilitate and increase transparency in trading.

This process towards liberalised electricity markets has been going on for some years. The EU directive on common rules for the internal market in electricity states that each member state has the right of access to the electricity transmission and distribution grids, thus opening the concept of free electricity trade in Europe. A number of countries already have or are in the transition phase of liberalising their electricity industry. Electricity exchange markets are being developed to facilitate electricity trade and now exist in several countries; among these are Germany, the Netherlands, England, Norway, Sweden, Finland and Denmark. How wind power is to be integrated into the competitive electricity market is still an open question. At present, most renewable energy technologies are not economically competitive to conventional power producing plants. Thus, it can be expected that this will halt the development of new renewable capacity if renewables must compete on pure market conditions.

## 1.2 Intermittence and Power Systems Integration

The introduction of large amounts of intermitting renewable power production such as wind power might interfere negatively with the technical and economical performance of the power system:

- If power from intermitting sources in periods exceeds the local/regional power demand congestion of transmissions, lines might cause technical instability of the power system;
- Fluctuating and difficult predictable power production from intermitting sources requires additional regulatory capabilities of the conventional power system, implying extra costs;
- Large amounts of wind power with low marginal costs might have considerable impact upon the functioning of the power spot market, including volatility of spot prices.

The reality of these problems is already encountered in the Northern part of Europe, where systems operators are facing grid-instability problems during periods of heavy wind, and the development of wind power is expected to continue. In recent years, a number of European countries have experienced a fast growth in the installation of wind turbines, e.g., Germany, Spain and Denmark. In all likelihood, this fast growth rate of wind power will continue in the years to come, which is also reflected in the 40000 MW target for wind power in 2010 in EU, put forward in the White Paper on renewables from the European Commission.

This fast expansion of wind power is to be introduced in electricity markets that are undergoing a process of market liberalisation as mentioned above. A consequence of the liberalisation is that the dispatch of the power plants in the electricity systems are increasingly being controlled by trading on power pools, as it is seen in a number of European countries: England, Poland, Germany, Sweden, Norway, Denmark, Finland, Spain and the Netherlands.

The other units must counteract fluctuations in the wind power production in the power system to maintain the stability of the power system. Therefore, larger amounts of wind power will require the presence of larger amounts of frequency-responding spinning power reserve<sup>1</sup> and supplemental power reserve<sup>2</sup> in the power system compared to a situation without wind power. The introduction of wind power, therefore, put strains on the performance of the other power-producing units in the electricity system.

On the economical side, the introduction of substantial amounts of wind power will influence the price on the spot market, because the marginal production price of wind power is very low (mainly operation and maintenance costs). The average price level on the regulating power market is expected to increase, because the unpredictability of wind power will cause trading of larger amounts of supplemental power compared to a situation without wind power. The handling of the technical impacts will, in some cases, be associated with an extra cost, as in the case of dedicated wind power integration measures such as reinforcement of transmission grids

---

1 The frequency-responding spinning power reserve in a power system is (normally large) power plants that respond with fast, automatic changes in their power production to changes in the electrical frequency of the grid.

2 The supplemental power reserve is power plants that can adjust their power production within 15 minutes. The system operator activates them manually.



or construction of electricity storages. The way these integration costs are distributed to the actors on the electricity market will have an economical impact thereon.

### **1.3 Objectives of Wilmar**

Wilmar is an abbreviation of “*Wind Power Integration in Liberalised Electricity Markets*”. The project was started in 2002 and is funded by the EU’s 5<sup>th</sup> Research programme on energy and environment. Risø National Laboratory is co-ordinator of the project and partners include SINTEF, Kungliga Tekniska Högskola, University of Stuttgart, VTT, Nord Pool Consult, Technical University of Denmark, ELSAM A/S and Elkraft-System A/S.

The aim of the Wilmar project is to investigate the above-mentioned technical and economical problems related to large-scale deployment of renewable sources and to develop a modelling tool that can handle system simulations for a larger geographical region with an International power exchange. When finalised, the model will be available to actors within the power sector, including power system operators, energy authorities, power producers and other potential investors within this field.

Thus, the objectives of the Wilmar project are:

1. To develop a strategic planning tool to analyse the integration of renewable power technologies to be applied by system operators, power producers, potential investors in renewable technologies and energy authorities;
2. To analyse the technical impacts connected to the introduction of substantial amounts of wind power in the Northern part of the European electricity system – covering the Nordic countries plus Germany. The issues of system stability connected to the fast (below 10 minutes) fluctuations in the wind power production will be analysed, as well as the issues of achieving an hour-per-hour power balance in the electricity system. Also, the long-term issue of securing the energy balance irrespective of the variation in the wind power and hydro-power production from year to year will be analysed;
3. To analyse the performance of different integration measures in a liberalised electricity system. Both possibilities for integrating fluctuating power production by optimising the interaction of the existing units in a given electricity system, the possibilities lying in power exchange between regions, and the performance of dedicated integration technologies such as electricity storages, will be evaluated. Special attention will be given to interactions between the integration measures and the organisation of the power pool.
4. To quantify the costs connected to the integration of large shares of wind power in a liberalised electricity system, i.e., to answer the question, what does it cost to integrate a certain amount of wind power in a liberalised energy system?

### **1.4 The Aim of this Report**

The modelling and simulation efforts of the Wilmar project are divided into two parts. One part consists of an investigation of the issue of system stability, i.e., the wind integration aspects connected to the fast (below 10 minutes) fluctuations in wind power production, with the use of dedicated power system simulation tools. It includes the analysis of a number of case studies, especially selected for large-scale integration of renewable energy generation and with expected potential stability problems.

In the second part, the wind integration ability of large electricity systems with substantial amounts of power trade in power pools is investigated. With the starting point in existing models, an hour-per-hour simulation model is developed, and this modelling tool is used to investigate the technical and cost issues of integrating large amounts of wind power into the electricity system. The model will cover the two power pools: Nord Pool and European Power Exchange, i.e., Germany, Denmark, Norway, Sweden and Finland. The developed model will be tested by different end-users, e.g., systems operators and power producers, who are expected to be users of the final model as well.

This report is especially related to the second part of the project. The starting points for the design of the power market models are the functioning of the electricity markets in Germany and in the Nordic countries, Denmark, Finland, Norway and Sweden. These two power markets are thoroughly described in Section 2 and 3 of this report. A qualitative description of the power market models used in Wilmar is given in Section 4, though the mathematical presentations of the models are left out of this report and will be treated in a later publication from the project.

The intention of the report is not to give a full documentation of the Planning model, but to concentrate on describing the ideas and assumptions behind the representation of the power markets to be included in the modelling tool. Full documentation of the Planning model will be given in Deliverable D6.2 to be published at a later stage of the project.

## 2 The Nordic Power Market

### 2.1 Markets of Importance to Power Trade in the Nordic Area

The Nord Pool power exchange is geographically bound to Norway, Sweden, Finland and Denmark. The market was established in 1991 and until the end of 1995, the electricity exchange covered Norway only. From 1996, Sweden joined the exchange and the name was changed to Nord Pool. In 1998, Finland was included and Denmark<sup>3</sup> joined in 1999-2000. At present, the market is dominated by Norwegian and Swedish hydropower, though power trade with neighbouring German markets are increasing and thus reducing the hydropower dominance. Because Denmark is situated on the border between the large conventional fossil fuel-based power systems of central Europe (especially Germany) and the hydro-dominated Nordic system, Denmark has the role as a sort of buffer between these systems. This implies that the price of power in the Danish area is partly related to the Nordic market and partly to the German one, depending on the situation in these markets.

The geographical boundaries of the Nord Pool power market are shown in Figure 1.

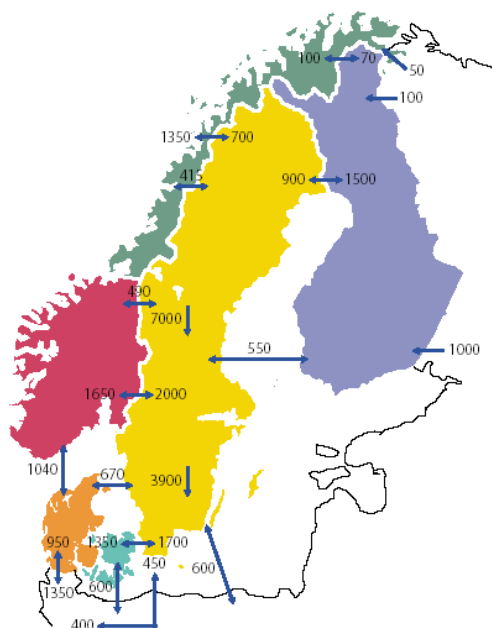

Figure 1: The geographical boundaries of the Nordic power market. Transmission capacities shown in MW. Source: NordEl.

3 Within the Nord Pool, Denmark is separated into two independent parts covering the Jutland/Funen area and Zealand, including the small neighbouring islands. These two parts are not directly electrically connected and, therefore, constitute two specific pricing areas in the market.

Three main principles characterise the liberalised Nordic power market. These principles are often seen as being fundamental for the creating of a well-functioning liberalised electricity market. In short, the principles concern the provision of:

- Equal opportunities for all actors to access the transmission grid and the setting up of independent TSO's to carry the responsibility for system balance and functioning. The TSO's must offer fair and neutral balancing services;
- Transmission tariff systems that must be unequivocal, transparent and non-discriminatory;
- Effective regulation power and balance markets sustained by the TSO's for enabling and maintaining reliable system operation and effective settling of actor imbalances.

In general, a number of markets exist servicing the Nordic power system. Most of these markets link directly to the physical delivery of electricity from producers to consumers and to the physical stability of the power transmission and distribution system to support the deliveries. Furthermore, other markets exist which facilitate or service the physical markets, e.g., concerning the handling of financial risks. Not all of these markets are implemented in all the Nordic countries and some markets may overlap in the type of service they provide. These markets are listed below and described briefly:

At present, markets for physical trade (NordEl, 2000):

- **Bilateral Electricity Trade or OTC (over the counter) Trading**  
This trade is outside the Nord Pool exchange, and prices and amounts are not publicised. Import/export transmission issues related to bilateral trade among Nord Pool price areas are handled by Nord Pool.
- **Elspot Market**  
Physical markets at the Nord Pool where prices and amounts are based on supply and demand. Resulting prices and the overall amounts traded are publicised. The spot market is a day ahead-market where bidding closes at noon for deliveries from midnight and 24 hours ahead. Hourly supply and demand is traded, but the market further supports block bidding, where supply and demand during linked hours may be traded as units. In 2002, the volume traded in Elspot represented about 32% of overall consumption in the Nordic region.
- **Elbas Market**  
Physical trading of adjusting/regulating power where bidding closes 1 hour before the operating/delivery hour. Elbas functions as an aftermarket to the Elspot market at Nord Pool and the Nord Pool maintains the Elbas market. The products traded are one-hour-long power contracts. Prices are publicised and based on supply and demand. Presently, Elbas comprises Finland and Sweden only, but extending Elbas is being considered.
- **Regulating Power Market (RPM)**  
Physical real time market covering operation within the hour. The main function of the RPM is to provide power regulation to counteract imbalances relative to planned operation according to the Elspot market trade. Only TSO's constitute the demand side at this market. Approved actors on the supply side of the RPM can be both electricity producers and consumers.

The RPM may be subdivided according to the different services provided, e.g., according to the response time for the regulation delivery. Secondary control

and tertiary control capacity differs according to the response time for the capacity to be online.

- **Balancing Markets**

Linked to the RPM. Concerns the later settling of actor imbalances recorded during the past 24 hour period of operation. Only the TSO for the area acts on the supply side for settling imbalances. Actors with imbalances on the spot market are price takers on the RPM/balance market. Thus, the TSO's act as the intermediary between suppliers of power regulation (at the RPM) and actors in demand of balance (being settled at the balance market).

Apart from these market structures, fewer formal markets exist where important physical deliverables or power system support services are traded. A general heading for these markets could be:

- **Auxiliary Service Markets/Ancillary Delivery Agreements**

The function of these markets/agreements is to provide/allocate, for example, primary, secondary and tertiary reserves for safe operation of the system within the operating hour, including frequency and voltage control. Furthermore, the needs for reserve capacity to counteract larger operation disturbances (e.g., due to plant or grid failure) and black start reserves, etc., are generally allocated via individual agreements between selected actors and the TSO. Presently, these (informal) markets are characterised by a few large actors within an area taking part on the supply side and the TSO on the demand side.

Auxiliary services cover a number of aspects relating to the physical functioning of the power system, which may be looked upon as (or split into) a number of different markets, each covering partly interrelated products.

- **Cross Border Transmission Capacity Auction Market**

Within the Nordic system, allocation of cross border transmission capacity corresponding to the power trade is governed or administered by Nord Pool. The Nordic TSO's have handed over the administration of grid bottlenecks within the Nordel system to Nord Pool and grid capacities are by doing this utilised to their maximum. Nord Pool handles bottlenecks via so-called implicit auction (or one stop shopping) where the power trading and the transmission capacity auction are combined into one transaction. This system allows actors to trade via the common exchange without considering the transmission capacities explicitly. However, capacity for cross border transmission (import/export) to/from the Nordic power system is still traded via specific auctions or bilateral trade of transmission channels.

Other and non-physical market concerns:

- **Eltermin**

Financial market supported by Nord Pool that handles, e.g., economic risk of actors. The market includes future and forward markets.

However, other markets relating to the Nordic power system may further emerge in the future. Such new considered markets are, e.g., markets for:

- TGC (Tradable Green Certificates) (Not implemented);
- GHG Emission Quota Market (Not implemented).

Moreover, new markets that enables diversified price settling of deliveries presently covered via more 'informal bulk markets' could be relevant, e.g.:

- Market for reserve capacity. (Not implemented);
- Markets for specified ancillary services to the grid (e.g., concerning frequency and voltage control reserves and black start). (Not implemented).

The main focus in this report will be on the physical markets that govern and impact the overall functioning of the power system. The Elspot market and the Regulating Power market are presently most important although other markets may directly or indirectly influence these two physical markets. The two markets (when fully developed) determine the basic dispatch of supply actors in the system and conditions for actors on the demand side, which ultimately may to some degree influence power consumption patterns.

The Elbas market may develop and become important in the future. It may eventually take over the trade at the Elspot market and elements from the Regulating power market due to its low minimum lead-time before delivery. The potential structures of future markets are generally, of course, very important for the functioning of power systems and the technical and economical efficiency of the systems.

The technical possibilities<sup>4</sup> for creating well functioning markets may to a large extent determine the type of actors that are present at the markets, the number of actors and the minimum volumes, or amount being traded, etc., and the transaction cost for handling markets. Likewise, such technical possibilities may to a large extent determine the supply at markets such as the Regulating Power market or potential markets covering ancillary services. In particular, an increased supply at the Regulating Power market may reduce costs at this market and/or may increase the capability of the overall system as to accumulate non-flexible production (and consumption). This is, of course, important, e.g., in relation to the integration of wind power due to its fluctuation and limited predictability.

Thus, the ability of the market to mobilise flexibility in the overall system and consequently to, for example, increase the supply of regulating power (both from the supply and the demand side of the system) is important. It is important for the economic performance or efficiency of the system and it is important for the capability of the system as to integrate power supplies of limited flexibility such as wind power, photo-voltaic, production at firm base load plants, etc.

As mentioned above, two markets within the Nordic power region are of special importance for wind power: The electricity spot market and the combined power regulating and balancing markets, where the spot market is the central energy market and the regulating market comes into force, if the bids to the spot market are not fulfilled. In the following, these two markets will be described in more detail.

## **2.2 The Nord Pool Spot Market**

### **The Bidding Procedure**

The Nord Pool spot market is a day-ahead market, where the price of power is determined by supply and demand. Power producers and consumers give their bids to

---

<sup>4</sup> For example, two-way communication systems at the consumption side of the power system.

the market 12 to 36 hours in advance, stating quantities of electricity supplied or demanded and the corresponding price. Then, for each hour, the price that clears the market (equalises supply with demand) is determined at the Nord Pool power exchange. In principle, all power producers and consumers can trade at the exchange today, but in reality, only big consumers (distribution and trading companies and large industries) and generators act on the market, while the small ones form trading co-operatives (as is the case for wind turbines) or engage with larger traders to act on their behalf. A minor part of total electricity production is actually traded at the spot market. The majority is sold on long-term contracts, but the determined spot prices have a considerable impact on prices agreed in these contracts (Morthorst, 2003).

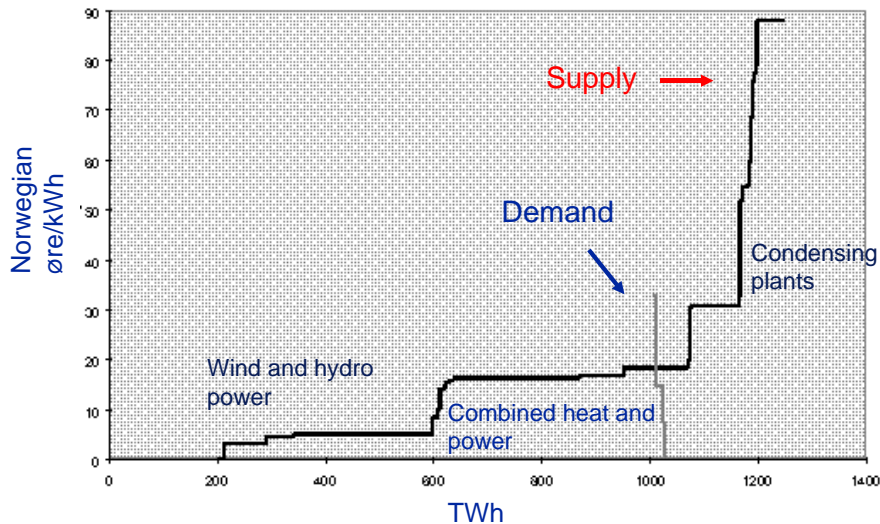

Figure 2: Supply and demand curve for the Nord Pool power exchange.

Figure 2 shows a typical example of an annual supply and a demand curve for the Nordic power system. As shown, the bids from hydro and wind power enter the supply curve at the lowest level owing to their low marginal costs, followed by combined heat and power plants, while condensing plants are those with the highest marginal costs of power production. In general, the demand for power is highly inelastic, mainly Norwegian and Swedish electro-boilers and power intensive industry contributing to price elasticity in power demand.

If trade of power can flow freely in the Nordic area, i.e., no congestions of transmission lines between the areas are observed, then only one price will exist at the market. But if the required power trade cannot be handled physically due to transmission constraints, the market is split into a number of submarkets. These submarkets are defined by pricing areas, for example, Denmark is split into two pricing areas (Jutland/Funen and Zealand). Thus, if more power was to be produced in the Jutland/Funen area than consumption and transmission capacity could cover, this area would constitute a sub-market, where supply and demand would be equalised at a lower price than the one existing at the general Nord Pool market.

### Pricing in Nord Pool

In a system dominated by hydropower, the spot price is heavily influenced by the precipitation in the area. This is shown in Figure 3 below, where the price ranges between a maximum of 350 NKR/MWh (approximately 42€/MWh) to close to zero. Thus, there were very wet periods in 1992 and 1993 and similarly in 1995

and 1998, although to a lesser extent. Dry periods dominated 1994 and the beginning of 1995, but a long period with precipitation significantly below the expected level was especially experienced in 1996.

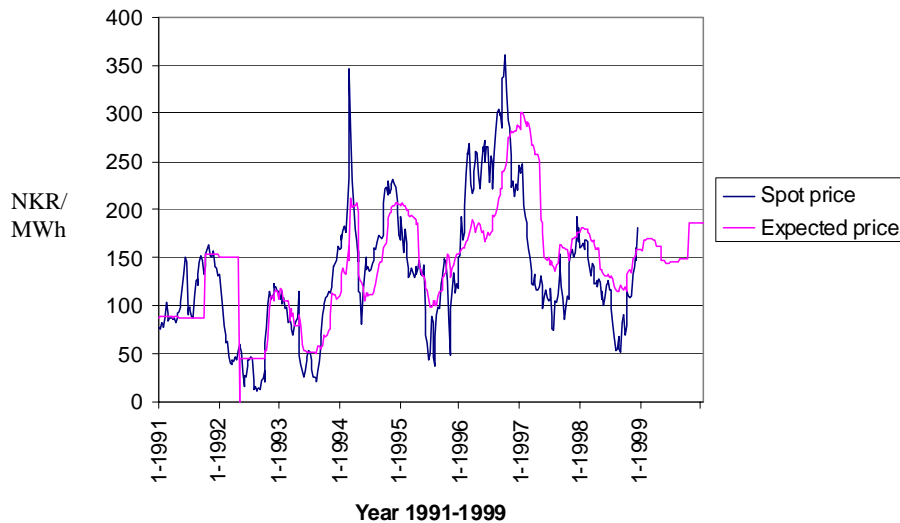

Figure 3: Price of power in the Nordic market in the period 1991-1999, Norwegian kr.

Looking at the last two years – the period where Denmark participated in the Nordic power exchange – prices have been fairly stable (cf. Figure 4), excluding the end of 2002 and the beginning of 2003.

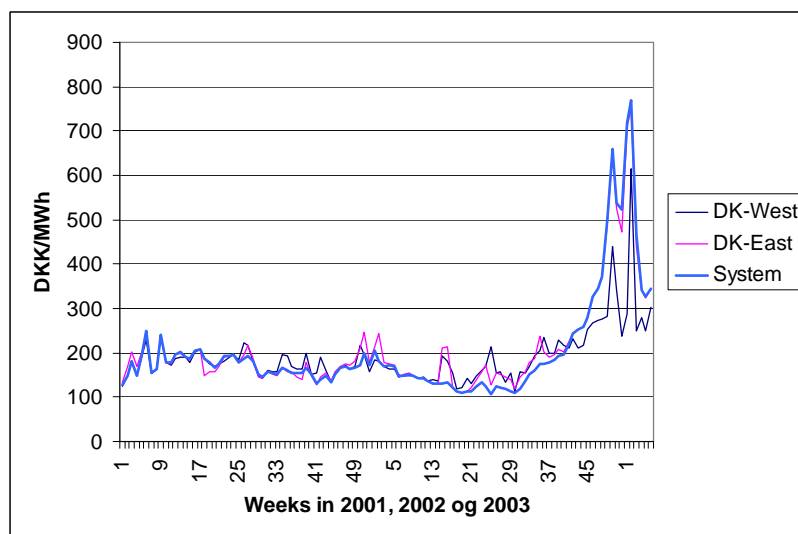

Figure 4: Power prices at the Nord Pool market in 2001, 2002 and the beginning of 2003, weekly average DKK/MWh (exchange rate 1€ = 7.45 DKK). Source: Nord Pool 2003.

The average price in 2001 and 2002 was approximately 2.5 c€/kWh, ranging between 1.5 c€/kWh and 8.8 c€/kWh. The Autumn of 2002 was, however, very dry in Norway and Sweden, which has heavily influenced prices in October, November and December 2002 and likewise in January 2003. Thus, if the last three months of 2002 are excluded from the considered period of time, the price ranged between 1.5 c€/kWh and 3.3 c€/kWh. But the draught in Norway and Sweden implied that prices rose to a high of more than 10 c€/kWh. Normality in power prices at the



Nordic market did not return before the Spring of 2003, due to the importance of hydropower. But high prices are only part of the abnormality of the present power market. As shown in Figure 4, the system price and the two area prices for Denmark West and East, respectively, are normally closely related, implying that congestions in the transmission-system seldom have major impacts upon price-determination. But this close relationship seems to have vanished at the end of 2002 and beginning of 2003, where prices in the Western Danish area differ quite considerably from the system prices, mainly owing to the high level of wind power penetration in this area.

### Case Study for Western Denmark

Experience on the integration of wind power in a small area, Jutland/Funen in Denmark, will be analysed in the following, as a case study. This area, the Western part of Denmark, has a number of specific characteristics (ELTRA, 2003):

- It has a very high share of wind-produced energy – in 2002, almost 20% of total power consumption was covered by wind power. Presently, most of wind-generated power is covered by prioritised dispatch;
- It has a high share of decentralised combination of heat and power, which is paid according to a three-level tariff and is also covered by prioritised dispatch;
- It lies on the border between the fossil fuel-based German power system and the hydropower dominated Nordic system and is thus heavily influenced by both areas.

In the following, it will be further investigated how well wind power actually is integrated into the power system in Western Denmark given those conditions mentioned above 56.

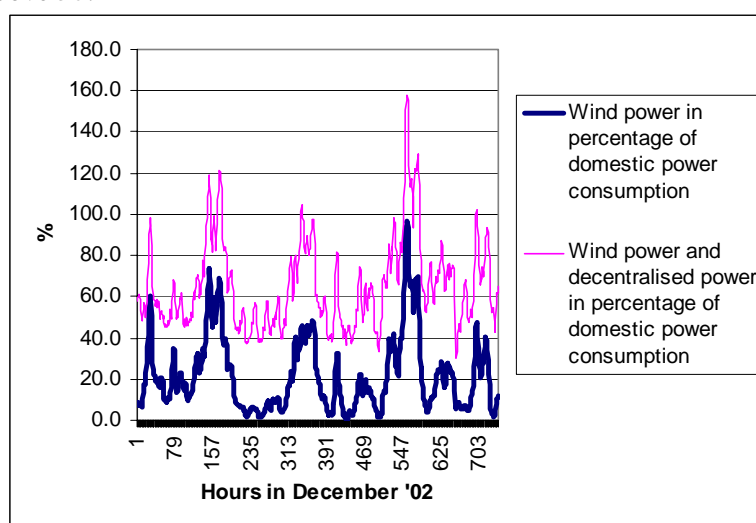
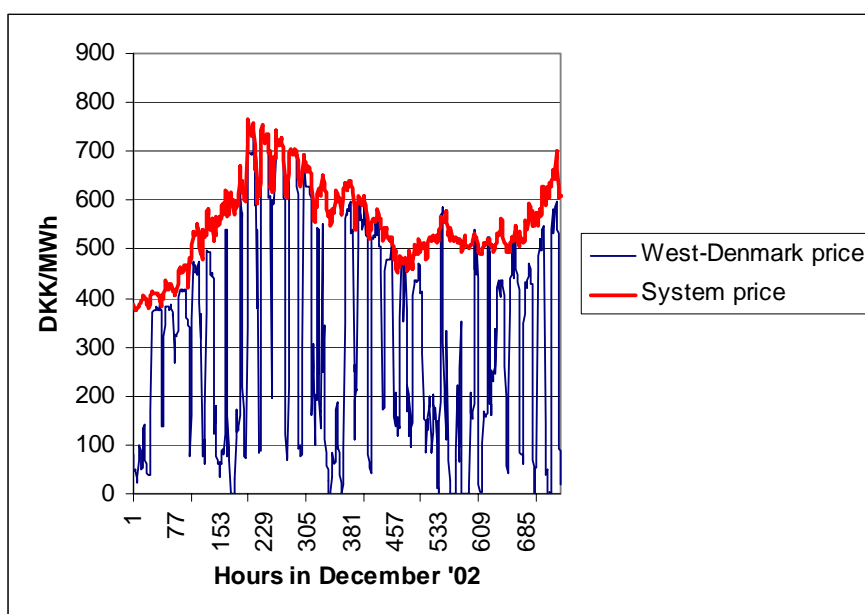

Figure 5: Wind-generated power and decentralised power as a percentage of total power consumption on an hourly basis in December 2002, Jutland/Funen area of Denmark.

5 If large amounts of wind power in the long-term are introduced into the power system, it might be expected that the marginal power price would in general decrease. This effect is not analysed in this paper, where only the short run consequences of large amounts of wind-produced power are taken into consideration.

6 In general, input data for the analyses performed in Section 3 and 4 are published on (ELTRA, 2003).

Figure 5 shows the share of wind-generated electricity in total power consumption in the Jutland/Funen area in December 2002. This month is chosen because it had on average the highest contribution by wind power, totalling 33% of domestic electricity consumption supplied by wind power that month. As shown, the share is close to 100% at certain points in time, indicating that all power consumption at that time could be supplied by wind power in this area. As mentioned above, a large part of the power generated by wind turbines is still covered by priority dispatch in Denmark, whilst this is also the case for power produced by decentralised combined heat and power plants. This implies that these producers do not react on the price signals from the spot market – wind producers under priority dispatch are paid the feed-in tariff for everything they produce, while decentralised CHP plants are paid according to a three-level tariff, highest in the daytime and lowest in the night-time. Thus, the last-mentioned ones will only produce at the low tariff if there is a need to fill the heat storages up. Therefore, total prioritised production was higher in Denmark for quite a number of hours in December than domestic power demand, thus adding to the problem of congestion of transmission lines.

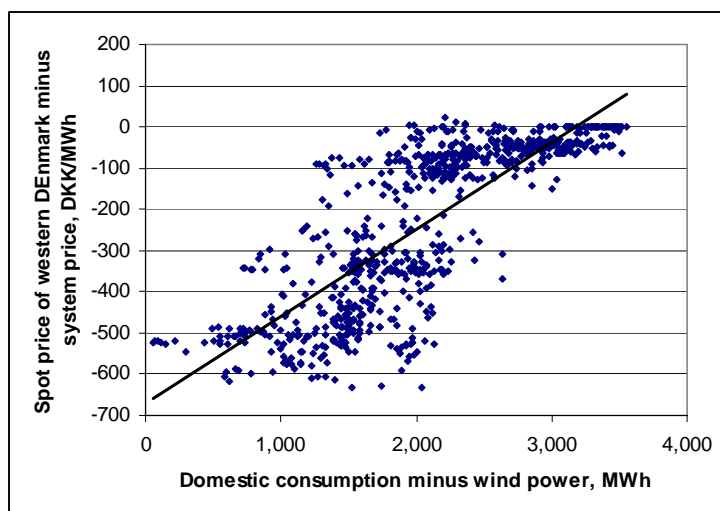

*Figure 6: Deviations between the system price of Nord Pool and the price of power in Western Denmark.*

The consequences are clearly shown in Figure 6, where deviations between the Nord Pool system price and the realised price in Western Denmark are depicted. As shown in a large number of hours, the Western Denmark price is significantly below the System price.

Therefore, a fairly strong relationship is found in this December case between the amount of wind power produced and a lower power price of the Western Denmark price compared to the general Nord Pool System price. This relationship is shown in Figure 7, where the domestic power consumption minus the generated wind power is plotted against the deviations between the spot price of Western Denmark and the System price. Thus, a high value at the horizontal axis indicates a small wind power production and thus only a small negative impact on the power price in Western Denmark. A small value at the horizontal axis indicates a high wind power production and, therefore, a high negative impact on the power price in Western Denmark. The regression line shown in Figure 7 is statistically significant and determined with an  $R^2$  of 0.65 – not a strong relation, but still significant. Thus, this

result shows that when fairly large amounts of wind power and power from decentralised CHP-plants are introduced to the market in December 2002, a considerable short-term impact upon the market price in Western-Denmark is found.



*Figure 7: Is there a relation between a high share of consumption covered by wind power and the price at the market? Domestic power consumption minus the production of wind power plotted against the difference between the West-Denmark spot price and the system price, hours in December 2002.*

The strong relationship in December is not found again when looking at the other months of 2002. The same story is partly found for November, but not as strong – the relationship is determined with an  $R^2$  of 0.32, which is insignificant. In no other month of 2002 has any significant relationship been found, i.e., it seems that for most of year 2002, the power system and market are, in general, capable of handling the wind-generated power without heavily influencing the spot market price in the short-term.

Thus, the results from these relatively few examples give a scattered picture. Though no strong conclusions can be drawn, it seems nevertheless relevant to emphasise the following issues:

- There is a tendency that more wind power in the system leads in the short-term to relatively lower spot prices, while less wind power implies relatively higher spot prices, although with the exemption of December 2002 where no strong relationship is generally found.
- Large amounts of wind power in the short run do not by itself imply large negative impacts upon the spot power price. In the Danish system, power produced by CHP plants are treated in the same way as wind power (prioritised) and, therefore, has the same impacts. If CHP plants were not treated as prioritised dispatch, more wind could in the short run be expectedly handled by the system.
- The situation at the end of 2002 with lower prices in Western Denmark compared to the rest of the Nordic market does not have a simple explanation. Though the capacity of wind has increased slightly during the year, less wind-produced electricity was actually supplied to the power system compared to February 2002. Thus, too much wind-generated power is not the only obstacle. Part of the answer could be that in periods with generally high spot prices, the

power systems and market are stressed; transmission capacity is in shortage because everybody is eager to export to Sweden and Norway at this high price. Thus, during periods with high spot prices, system interactions might make it more difficult and expensive to handle wind power.

- Many partly exogenous factors are influencing the price determination at the spot market in the short-term, including weather conditions (temperature), if the capacity of transmission lines is constrained for other reasons and what are the price conditions in our neighbouring countries. Therefore, it is difficult to single out one factor to be the most important one influencing the spot power price in the short run.

## **2.3 The Nordic Regulating and Balancing Market**

### **The Functioning of the Regulating and Balancing Markets**

Imbalances relative to the physical trade on the spot market must be levelled out in order to maintain equality between production and consumption and to maintain power grid stability. Deviations from the bids at the spot market for all actors add up to the net imbalance at the hour for the overall grid. In case of bottlenecks in the grid, the overall market degenerates into regions, or areas, and balance must be established in each such area. The main tool for correcting such imbalances, which provides the necessary physical trade and accounting in the liberalised Nordic electricity system, is called the Regulating market.

The Regulating Power market and the Balancing market may be regarded as only one market, where the TSO acts as an important intermediate or facilitator between supply and demand of power regulation. The TSO is the responsible body for securing the system functioning in a region. Within its region, the TSO controls and manages the grid, and to this end, the combined Regulating Power and Balancing market is an important tool for managing the balance and grid stability (NordEl, 2002).

The basic principle for settling imbalances is that actors causing or contributing to the imbalance shall accordingly pay their share of the costs for re-establishing the balance.

Settling of imbalances among countries has since September 2002 been done based on common rules for the Nordic countries (NordEl decision). However, the settling of imbalances within a region differs from country to country. Work is being done to analyse options for harmonising these rules, also for the Nordic countries.

Thus, if the bids by generators and consumers to the spot market are not fulfilled, the regulating market has to come into force and this is especially important for wind-based power producers. The producers state bids on the regulating market 1-2 hours before the actual production hour and power production from the bidding actors must be available within 15 minutes notice. For those reasons, only fast responding power capacity will normally be able to deliver regulating power.

It will to a certain extent only normally be possible to predict the supply of wind power 12-36 hours in advance. Thus, it will be necessary to pay a premium for the difference between the sales bid to the spot market and the actual delivery to the market. Figure 8 shows how the regulatory market functions: If the power production from, e.g., the wind turbines is higher than the bid, other producers will have

to regulate down or consumption must increase in order to maintain power balance. In this case, the wind producer will get a lower price for the excess electricity produced than the spot market price. If wind power production is lower than the bid, other producers will have to regulate up to secure the power supply, or consumption must be reduced. These other producers will obtain a price above the spot market price for the extra electricity produced, an additional cost, which has to be borne by the wind producer. The more the wind producer is off track, the higher the premium is expected to be, as shown in Figure 8 by the difference from the regulatory curves to the stipulated spot market price.

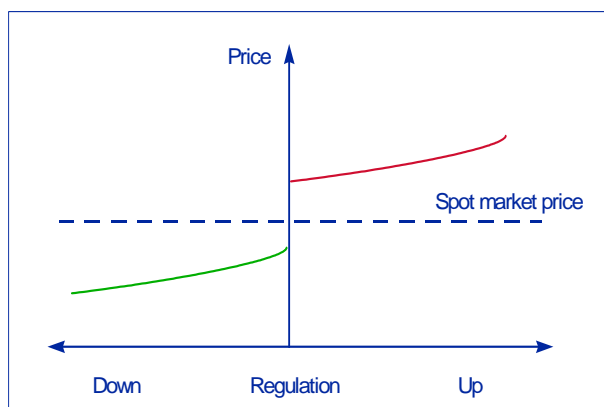

Figure 8: The functioning of the regulatory market.

Until the end of 2002, each country participating in the Nord Pool market had its own regulatory market. Thus, what is discussed above is fairly close to the Norwegian way of handling the regulatory market. In Denmark, balancing was handled by agreements with the largest power producers, supplemented by possibilities of the TSO's to buy balancing power from abroad if the domestic producers were too expensive or not able to produce the required volumes of regulatory power. A common Nordic regulatory market was established at the beginning of 2003 and both Danish areas are, as expected, going to participate in this market.

In Norway, Sweden and Finland, all suppliers at the regulating market will receive the marginal price for power regulation at the specific hour. In Denmark, suppliers at the market get the price of their bid to the regulation market. Prices for up and down regulation form the basis for settling imbalances between areas and for settling imbalances of the individual actors at the particular hour. If no overall regulation has been required, the regulation price is placed equal to the system price.

In case of no bottlenecks, the regulation price is the same in all areas. In case of bottlenecks to one or more areas, bids from these areas at the regulating market are not taken into account when forming the regulation price for the rest of the system, and the regulation price within the area will differ from the system regulation price.

In Norway, only one regulation price is defined and this is used both for sales and purchase on the hour when settling imbalances of individual actors. In the other countries two prices are generally defined, a sales price and a purchase price, and these are used for settling imbalances of actors depending on the direction of their imbalance. The two-price system forms incentives for the actors for avoiding imbalances to a larger extent than is the case in a one-price system. In the one-price system, there is always a monetary balance for the regulation at the hour, whereas in the two-price system, a surplus is generated for the TSO's to cover expenses relating to handling the balancing service.

When bids have to be stated to the spot market 12-36 hours in advance, it will not be possible for wind producers to fulfil this bid at all times. To get other power producers to regulate according to the unfulfilled part has a price, and with wind power gradually entering the spot market, this price will in the future have to be borne by the owners of wind power plants. Until the end of 2002, the TSO's have been obliged to handle the regulation in Denmark, wind power being a prioritised dispatch. From the beginning of 2003, the owners of those turbines supplying the spot market are also financially responsible for balancing the power themselves. They can either continue to let the TSO's handle the balancing and pay the associated costs, or they can hand over the work to private companies. In Denmark, some of the wind turbine owners have formed a co-operative for handling the spot market trading and balancing of their turbines and this co-operative covers by now the majority of owners entering the spot market.

### Case Study: Wind Power and the Balancing Market

But what quantities are actually regulated and what is the cost associated with the balancing of power production from wind turbines? In the following, the quantities and costs reported by the TSO for Jutland/Funen will for some specific periods be analysed in more detail.

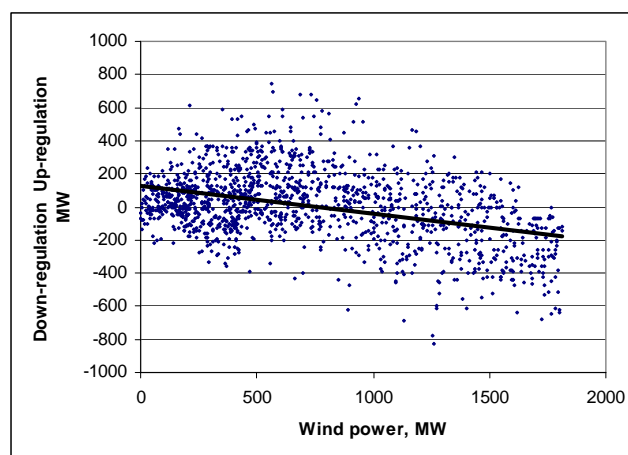

Figure 9: Regression analysis of down or up regulation against the amount of wind power for the Jutland/Funen area. Hourly basis for January-February 2002. Based on data from (ELTRA, 2003).

In Figure 9, a regression analysis is performed for the need to regulating up and down, respectively, against the produced quantity of wind power. The analysis is carried out for some specific periods of time for the Western part of Denmark, namely the Jutland/Funen area. The first two months of 2002 are analysed because of their high wind power production –wind power supplied approximately 24% of total power consumption in January 2002, while 33% was covered in February.

Figure 9 shows the overall regulation capacity applied in the Jutland/Funen area on an hourly basis and plotted against the wind power production in the area for the same hours. An observation above the horizontal zero-line in the figure indicates that up-regulation is registered at that hour, while an observation below the zero-line shows that capacity for regulating down is registered.

As mentioned above, there will be a need for regulation when wind power cannot fulfil the bids given to the spot market. But other actors at the spot market might

also have a need for regulating power, due to changes in demand, such as power plants having to shut down, etc. In Figure 9, the capacities shown are related to total regulation, not only regulation undertaken due to wind power bids not being fulfilled<sup>7</sup>. Nevertheless, although not very significant, there is a clear tendency that the more wind power produced, the higher is the need for down-regulation. Correspondingly, the less wind power produced, the higher is the need for up-regulation. Please observe that what is shown in Figure 9 is that the forecasts for wind-produced energy tend to be too low, when much wind power is produced, and tend to be too high, when only small amounts of wind-generated power enter the system. The reason is that the forecast is bounded between 0 and 100%. That means that a low forecast has an asymmetric potential for error, only a small overprediction is possible, but a large underprediction.

Finally, Figure 10 shows the monthly quantities regulated (numerically) for 2002 in the Western part of Denmark as a percentage of the total power supply and as a percentage of the conventional power production only. The percentage relative to the conventional power supply is calculated, because these power plants are the ones being capable of regulating the power. As shown, the percentage of conventional power production to be regulated can be rather high, especially during Summer-time. Please observe that the percentage to be regulated is not higher in the Autumn/Winter of 2002, indicating that wind power is not the only reason for the lower prices in the Western part of Denmark during December of that year, as discussed in the previous section. The average percentage being regulated in the year 2002 is calculated to 5.6% of total power supply and to almost 10% of conventional produced power.

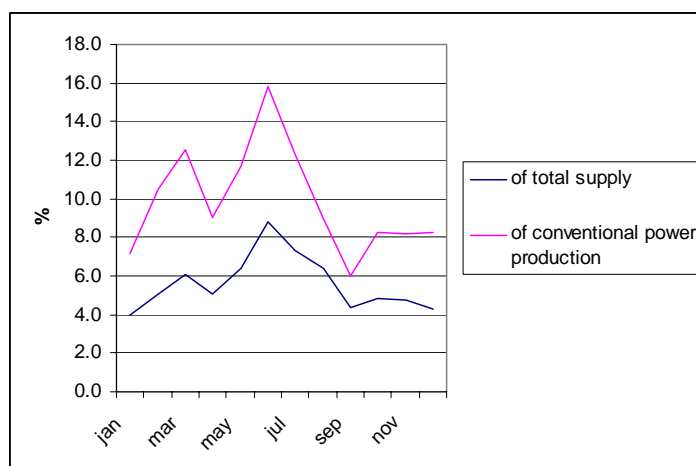

Figure 10: The regulated quantities as percentages of total supply and of conventional power production, respectively (monthly average).

A wind turbine owner producing more than his bid will receive the spot price for all his production, but he will have to pay a premium for other power plants to regulate down, because his production is exceeding his bid. If he produces less than his bid, he will correspondingly have to pay a premium for the part other generators have to produce in up-regulation. The costs of regulation within the Jutland/Funen area of Denmark are shown on an hourly basis in Figure 11 for January and February 2002. Thus, the amounts of wind power produced at the specific hour are shown at the x-axis, while the cost per MWh of regulation is shown at the y-axis.

<sup>7</sup> It is not possible in the available data, to sort out the specific unfulfilment of wind power.

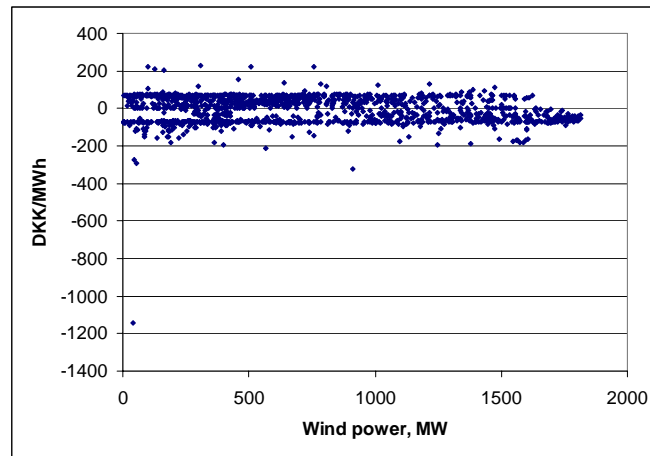

Figure 11: The cost of regulation in the Jutland/Funen area. Hourly basis for January-February 2002.

The picture is quite clear with a “band” of costs, both for up and down regulation being almost independent of how much wind power is generated within the specific hour. Thus, although the need for regulation is increasing with higher quantities of wind power produced, the regulating costs are seen to be almost independent of the level of required regulation. The average cost of regulating up is calculated to 0.8 c€/kWh regulated, while the cost of regulating down correspondingly amounts to 0.6 c€/kWh regulated in the period January-February 2002.

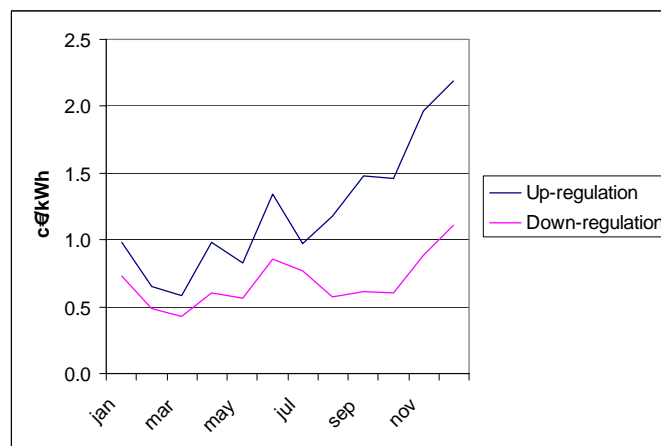

Figure 12: The cost of regulation calculated as monthly averages for the year 2002 in respect of the Jutland/Funen area.

Figure 12 shows the regulation costs for the whole of 2002 calculated as monthly averages. As seen from the figure, the cost of up-regulation is constantly above the cost of down-regulation, probably because the marginal cost of up-regulation is higher for power producers than regulating down the production. Moreover, the cost of regulation – especially again up-regulation – is not surprisingly increasing with the general level of the spot price, which increased heavily towards the end of 2002. For 2002, the average of up-regulation cost is calculated at 1.2 c€/kWh regulated, while the cost of down regulation amounts to 0.7 c€/kWh regulated.

As mentioned, the regulated quantities do not only relate to wind power, but also to the total system, including non-fulfilment of bids from demand and conventional power producers as well. But well-knowing that the estimate is an upper bound, the monthly regulation costs for the Western part of Denmark for 2002 are in Figure 13



only related to wind power. Furthermore, for comparison, the costs are in Figure 13 correspondingly related to the total power supply.

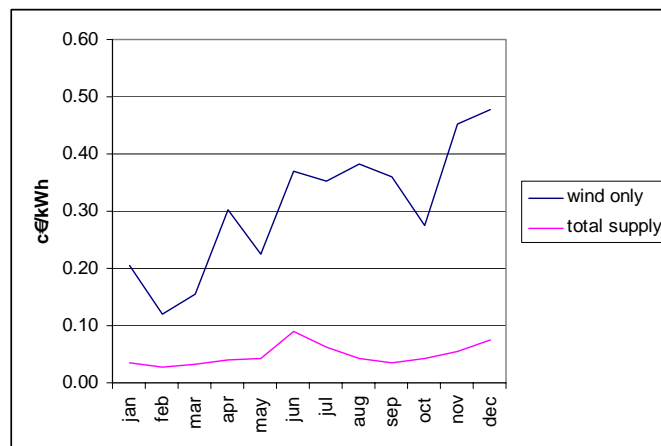

*Figure 13: Regulation costs calculated as monthly averages for the Jutland/Funen area for 2002, if costs are born by wind power only or are related to the total power supply.*

As shown in Figure 13, regulation costs per kWh born by wind power only are smallest in periods with plenty of wind-generated power, i.e. in the Winter/Spring of 2002, and higher in the Summer-time, where less wind power is produced. Again, the Autumn/Winter of 2002 with the high spot prices is seen to be an exception though. The average regulation cost if born by wind power only is calculated at 0.3 c€/kWh for the year 20028. As mentioned above, these estimates constitute an upper bound for the regulation costs for wind energy, because the regulated quantities not only relate to wind power. Of course, if the regulation costs are distributed across the total power supply, the costs per kWh are much lower, and if calculated as an average over 2002, the cost amounts to 0.05 c€/kWh.

---

<sup>8</sup> If 2002 is a representative year for regulating, costs are not known.

# 3 The German Electricity Market

## 3.1 Introduction

The European Energy Exchange (EEX) is Germany's energy exchange and thereby one of the biggest power markets in Continental Europe. EEX emerged in 2002 from the merger of EEX Leipzig Power Exchange and EEX European Energy Exchange Frankfurt and is now located in Leipzig. Both exchanges initially started Spot Trading for physical contracts (*Spot Market*) in 2000. This so-called day-ahead market includes daily trade for electricity delivered on the next day. In 2001, EEX Frankfurt also introduced trading of standardised financial contracts (*Futures Market*). The following sections are mainly based on EEX,2002a and 2003a for the Spot Market (cf. section 3.2), EEX,2002b and 2003b for the Futures Market (cf. section 3.3) and Swider and Weber, 2003 a and b for the Regulating Power Markets (cf. section 3.4).

## 3.2 The EEX Spot Market

The EEX Spot Market's main role is to facilitate the short-term trade of standardised products. Thus, the trading participants will have the possibility to balance their purchase and sale obligations in the short run. Furthermore, EEX's role is to promote the exchange of market information as well as the competition and the liquidity of the power market. The EEX Spot Market may be briefly characterised as follows:

- The Spot Market concept is based on bids for purchase and sale in respect of hourly power contracts for the 24 hours of the following day and on bloc bids.
- Trading is executed one day prior to physical delivery taking place. For this reason, the Spot Market is referred to as a-day-ahead market.
- The EEX Spot Market offers two different trading platforms, i.e., the closed auction trading for hourly contracts and bloc contracts and the continuous trading in connection with open Opening and Closing auction for Base as well as Peak Load contracts. Both trading schemes will be discussed in greater detail in the following sections.
- If there are no capacity constraints, there will be only one price for Germany in the hourly auction – the unconstrained Market Clearing Price (MCP). The price mechanism can also be used to relieve constraints in the main transmission grid. Therefore, the whole market is divided into bid areas. A bid area is either the area of one Transmission System Operator (TSO) or consists of two (or more) connected TSO –areas, where the TSO's involved have agreed to cooperate in case of activities at the interface towards EEX. There are currently four bid areas in Germany. Purchase and sale bids have to be placed separately for each bid area. Bid areas may form separate price areas in the case of constraints.
- EEX is the counterpart for Spot transactions and will also exercise the financial settlement of the transactions.
- Resident and foreign participants are admitted to the trade at the EEX Spot Market. If a participant wishes to import power from abroad to Germany or to export power from Germany, he will have to obtain the right to use the trans-

mission capacity on the International interconnection point. Furthermore, trading participants have to conclude a balance agreement with the balance responsible of the relevant bid areas.

Hourly power contracts with constant performance from 0,1 MW in an hour in 0.1 MW-steps are traded on the EEX Spot Market for delivery on the following day. It is also possible to trade blocs, which means a number of connected hours. It is distinguished between bloc contracts in the hourly auction and Base as well as Peak Load contracts from continuous trading. Contrary to the bloc contracts of the hourly auction, the smallest trading unit of Base as well as Peak Load contracts in continuous trading is 1 MW in each hour of the respective period (Base or Peak Load period) for the following day. On trading days, contracts can be concluded for all of the 365 days of a year. Trading days are the weekdays Monday to Friday, excluding statutory public holidays.

### **Closed Auction**

The EEX Spot Market makes use of the bilateral auction bidding for price determination in connection with a closed Order Book. Auction bidding is characterised by the collection of all bids in order to use them for price determination at a certain point of time. Since supply as well as demand contributes to the price determination, it is called bilateral auction bidding. The bids submitted by a market participant are not revealed to the other market participants, so the possibility of market or price manipulations is hereby eliminated. This procedure is referred to as a closed auction.

Based on his trading strategies, the trading participant plans how to handle the production and the contractual rights and commitments for the next 24 hours. Considering his trading strategy, the trading participant may decide between hourly bids and bloc contracts. The hourly bids can be divided into price dependent, price independent and flexible bids:

- *Price dependent bids* can be placed by giving the volumes (per hour) with single, selectable prices within the valid price scale with up to 198 price intervals.
- With *price independent bids*, hedged volumes are obtained. The trading participant will always obtain the volumes at the market price. Giving the same value for the upper and lower price limit places a price independent bid.
- *Flexible hourly bids* are asking bids, which are executably related to the price limit in the hour that is the most expensive hour before the integration of the bid. The bid will be executed in the hour with the highest price provided that the price limit criteria is met. The most expensive hour is the hour, which, after the price calculation – and before the integration of the flexible hourly bid in the price calculation – shows the highest price on the basis of all hourly and block prices.

The offered EEX bloc contracts in the closed auction are summarised in Table 1. The number of bloc contracts as well as the maximum volume per bloc bid is published by EEX. The maximum volume per bloc bid is 250 MW. The number of permitted bloc bids per participant is limited to six blocs. The bloc bids are integrated in the hourly auction by transforming bloc contracts into price independent bids for the hours concerned.

Table 1: Definition of EEX bloc contracts in the closed auction.

No.	Block description	Delivery times
01	EEX Night	Hour 01 to Hour 06 (00.00 am - 06.00 am)
02	EEX Morning	Hour 07 to Hour 10 (06.00 am - 10.00 am)
03	EEX High-Noon	Hour 11 to Hour 14 (10.00 am - 02.00 pm)
04	EEX Afternoon	Hour 15 to Hour 18 (02.00 pm - 06.00 pm)
05	EEX Evening	Hour 19 to Hour 24 (06.00 pm - 00.00 pm)
06	Rush-Hour	Hour 17 to Hour 20 (04.00 pm - 08.00 pm)
07	Baseload	Hour 01 to Hour 24 (00.00 am - 24.00 pm)
08	Peakload	Hour 09 to Hour 20 (08.00 am - 08.00 pm)
09	Off Peak 1	Hour 01 to Hour 08 (00.00 am - 08.00 am)
10	Off Peak 2	Hour 21 to Hour 24 (08.00 pm - 08.00 pm)

The price calculation during the closed auction follows three steps. In case of a sufficient capacity of the transmission system, the results of step 1 and 3 are identical. The bids for purchase and sale are collected up to 12 noon on a trading day. At 12 noon, the prices and volumes for the following day are calculated. Before calculating the prices, all bloc contracts are transformed into price independent bids after which, the price-volume-combinations for every hour of the day of delivery are transformed into a sale and purchase curve by linear interpolation (two neighbouring price-volume-combinations are interpolated at a time). As a result of this, a volume can be assigned to each price and vice versa.

The first step is the aggregation of the resulting participant dependent supply and demand curves to a single supply curve and a single demand curve for all Germany. The intersection between the two curves represents the balance between purchase and sale bids and determines the market-clearing price (MCP).

The following two steps are needed for the determination of the net contractual flow between the TSO areas.

In the second calculation step, the individual supply and demand curves are only aggregated per bid area (corresponds usually to a TSO area). The intersection of the area-related supply and demand curves represents the market-clearing price for every bid area.

Thirdly, the price differences of the bid areas are reduced by varying the volumes in such a way that price independent demands are introduced to bid areas where the area price is lower than the market-clearing price. Price independent offers are introduced to bid areas where the area price is higher than the market clearing price. Thus, a (contractual) power flow is created between the bid areas in which the introduced offers and demands sum up to zero. The levelling out of prices begins in areas where the area prices show the highest positive and negative deviation. The same procedure is applied to the remaining areas.

As long as the calculated (contractual) power flow is lower than the transmission capacity allocated to EEX by the TSO's, or as long as the TSO's had not informed EEX on any transmission constraints, the area's prices will be completely levelled out and the market-clearing price is thereby effective in all areas. The volumes determined in the course of price calculation are rounded down or up and given one decimal place; the rounded prices are given two decimal places.

The closed auction trading process is briefly summarised in Table 2.

Table 2: Brief description of the closed auction trading process.

Time	Measures
Day before transaction at 2.30 p.m.	The Transmission system operators inform about capacities or possible constraints between the bid areas on their web pages.
Trading day until noon	Bids to be fulfilled on the following day have to be electronically transferred to EEX.
Noon to 12.30 p.m.	EEX starts the price calculation. The market data is published on the Internet until 12.30 p.m., and all market participants are informed about traded volumes and prices.
Following 30 minutes	Complaints can be lodged up.
From 1.00 p.m.	Benchmark data concerning invoices and credits are transmitted to the participants. The TSO's receive the schedules for their areas.
2.30 p.m.	Trading procedure is finished.

### Continuous Trading

The daily trading procedure is divided into the sections Pre-trading, Main trading and Post trading. The beginning, end and the duration of each section are determined by the EEX.

The *Pre-Trading Phase* starts at 7.30 a.m. (CET). Exchange participants can input, annul or change bids and request orders. No transactions are matched. The Order Book of the whole market is invisible to the market participants. If available, the last determined contract price on the previous day in the same category is indicated.

The *Main Trading Phase* is sub-divided into Opening auction, Continuous trading and Closing auction. It lasts from 8.00 a.m. to approx. noon (CET).

- Before the beginning of the Continuous trading, an *Opening Auction* takes place, consisting of Opening call, price determination and Order Book balancing phase. It starts at 8.00 a.m. (CET) and lasts until approx. 8.01 a.m. (CET). Basically, all Orders already entered participate in this auction, unless their execution has been restricted to the Closing auction.
- *Continuous Trading* is initiated following the Opening auction at 8.01 a.m. (CET) and finishes at 11.55 a.m. (CET). During Continuous trading, the Order Book is open, thus displaying the limits, the accumulated order quantities and the number of orders in the Order Book at each limit. Each incoming order is immediately checked to see if it is executable against orders on the other side of the Order Book.
- The *Closing Auction* is initiated at the end of Continuous trading. It also comprises a call phase, price determination and Order Book balancing phase. The Order Book is partially closed during the closing auction. It starts at 11.55 a.m. (CET) and lasts until 12.00 noon (CET). All remaining orders in the Order Book participate automatically in the Closing auction. Any outstanding orders are deleted at the end of the day.

The trades executed can be processed during the *Post Trading Phase*. It begins with the end of the Closing auction and finishes at 5.00 p.m. (CET). The contracts available for continuous trading at EEX are summarised in Table 3. For all contracts, the smallest tradable unit is 1 MW for each delivery hour. Regarding the contract volume, this means for the Base Load Contract 24 MWh, for the Peak

Load contract 12 MWh and for the Weekend Base Load 48 MWh (resp. 47 MWh on the day of switching from Winter-time to daylight saving time and 49 MWh on the day of switching back from daylight saving time to Winter-time).

*Table 3: Definition of EEX contracts in continuous trading.*

No.	Contract Description	Delivery Times
01	Base Load	Hour 01 - hour 24 (00.00 a.m. - 00.00 p.m.) for all weekdays
02	Peak Load	Hour 09 - hour 20 (08.00 a.m. - 08.00 p.m.) for the weekdays Monday to Friday
03	Weekend Base Load	Hour 01 - hour 24 (00.00 a.m. - 00.00 p.m.) combined for Saturday and Sunday

Prices are determined during Continuous trading and at the end of the Opening and Closing auction. The price determination takes place automatically. In the Order Book, all orders are primarily sorted according to price and after that according to time of receipt.

The auction price is determined on the basis of the Order Book situation at the end of the call phase. The auction price is the price with the highest executable order volume and the lowest surplus across all limits in the Order Book (principle of most executable volume).

The price in continuous trading is determined by immediately checking each incoming order to see if it is executable against orders on the other side of the Order Book. Execution is subject to price/time priority. Orders can be executed in full, in part or not at all, so that none, one or several business transactions are generated. Market Orders, which have not been executed in the Order Book must be executed immediately with the next transaction (if possible).

### **Analysis of Prices and Volume**

As in most worldwide electricity markets, German spot market prices for electricity are characterised by (cf. also Johnson, Barz 1999):

- Daily, weekly and seasonal cycles;
- High volatility;
- Mean reversion and
- Spikes.

This is illustrated in Figure 14, thereby showing daily price averages for peak and base products in the day-ahead market, the hourly prices even exhibit higher volatility and spikes. Several analyses have highlighted that among all traded commodities, electricity exhibits the highest volatilities (e.g., Pilipovic 1998). A major reason for these strong fluctuations is the non-storability of electricity. It implies that at each moment in time, supply has to match demand and in peak demand hours, prices may increase drastically, especially if some unforeseen plant outages lead to capacity shortages. It is worth mentioning that in the hydro-dominated Nordic power market, electricity prices exhibit much less short-term fluctuations. The consequence of the storability of water is that electricity prices behave much more like those of a storable commodity, even if electricity itself remains non-storable.

The daily trading volume at EEX closed auction is given in Figure 15. This has increased considerably over time.

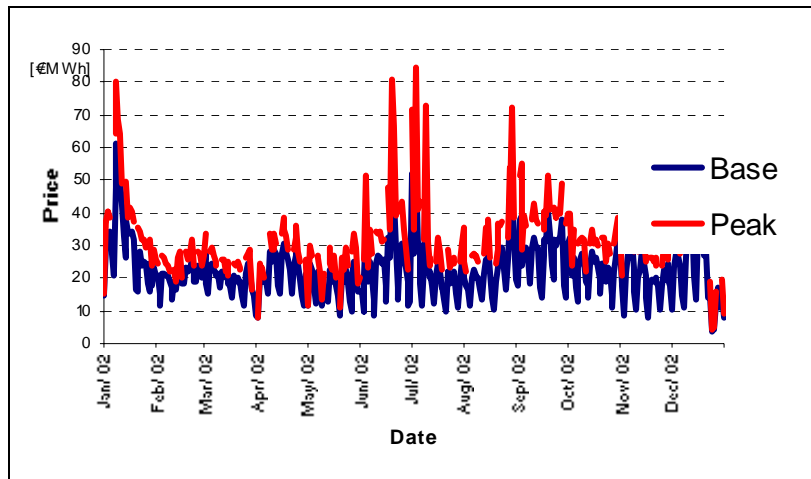

Figure 14: Daily averaged hourly spot market price at EEX closed auction in (€/MWh).

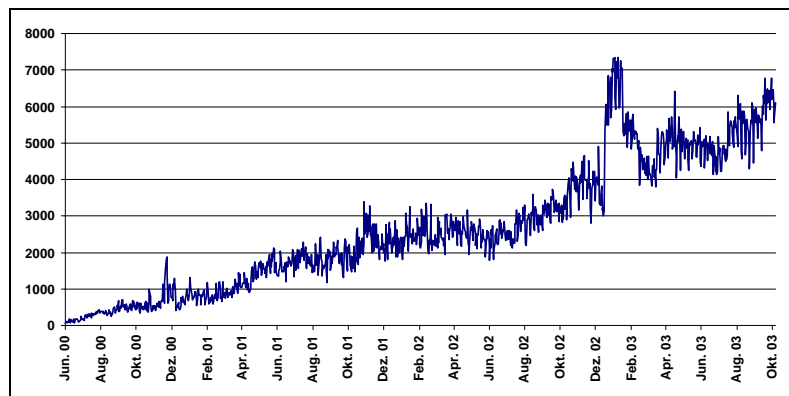

Figure 15: Daily averaged hourly spot market volume at EEX closed auction in (MWh).

### 3.3 The German Forward and Futures Markets

Economic trading always has associated risks. This applies especially to the electricity business, where the economical success of a company strongly depends on the market price for electricity. The EEX futures market supports the market participants in managing the market price, counterparts, volume, basic and liquidity risk. Hence, a futures market may support the risk management that is based on the economic necessity and is required by law.

Futures are standardised forward transactions, traded on an exchange. Volume, place of delivery, delivery time, quality, financial and physical administration are all standardised, respectively. Both buyer and seller agree on the current date to respectively call-off to supply a certain quantity of electricity (according to the contract specifications) at a time in the future (delivery period) for a certain price, or to effect respective payments.

Maximum tradable delivery periods are the next six months, the current delivery month, the next seven quarters and the next three years. The contracts are divided

not just into delivery periods, but also in load types; Base Load and Peak Load. Base Load includes the delivery days from Monday to Sunday for all 24 hours of the day. Peak Load includes the days from Monday to Friday, including national holidays, but only between the hours of 8.00 a.m. to 8.00 p.m. (CET). Finally, the contract volume denotes a delivery rate of electricity per hour, which underlies the settlement payment. The delivery rate per contract is 1 MW during each delivery hour of the delivery period. This results, for example, in a contract volume for the Base Load Monthly Futures for September of: 24 h per day times 30 days times 1 MW equals 720 MWh.

Monthly Futures are fulfilled by cash settlement. No physical delivery takes place during the delivery period, but buyer and seller of the Futures receive payments, or have to effect payments until the end of the delivery period, respectively, until closing of the position. The settlement price for Month Futures on the last trading day is called Final Settlement Price. The Final Settlement Price is the daily weighted average (arithmetical monthly mean) of Base respectively Peak Contract for the delivery month. Those reflect the average of the prices of all 24 single hours on the EEX auction market. Thus, the final settlement price is the price at which the power supply was realised for the respective month and load type on the EEX auction market.

Cascading fulfills quarterly and yearly contracts. Cascading means the automatic splitting of long-term contracts into contracts with the next shortest period of validity on the last trading day.

Besides cash settlement and cascading, each trading participant has the opportunity of closing or netting his position by the opening of a contrary position until the end of the delivery period and the cascading (see above). Closing for Month Futures is also possible during delivery period.

The daily trading procedure is quite similar to the continuous action described above and is hence divided into the sections Pre-trading, Main trade and Post trading. The exchange management automatically, or manually, carries out the transition from one trading section to the next. During these trading phases, each contract traded passes through this daily procedure at least once per day. The trading takes place during the exchange trading days. Exchange trading days are all working days with the exception of official holidays listed in the Public holiday calendar, and weekends.

The *Pre-Trading Phase* starts approx. 8.30 a.m. and lasts until 8.55 a.m. Trading participants can input, annul or change bid and ask orders. No transactions are matched and no price information is announced at this time, i.e., the market is closed.

The *Main Trading Phase* is sub-divided into Opening phase and Continuous trading. It lasts until 4.00 p.m. for all contracts, respectively, until 12.00 noon for monthly contracts on their last trading day.

- During the *Opening Phase*, the participants may amend their order book. In contrast to Pre-trading, an indicative market price is permanently on view to lend an indication on the market. This is the price resulting as auction price if the price setting would have finished at this time. If no indicative market price can be established, the price of the highest limited asked and the price of the lowest limited bid contract is shown.
- During *Continuous Trading*, the Order Book is open, each market participant can see the orders currently in the system, but not which participant is involved. The participants can enter new orders or react to existing orders in the



Order Book. Every new order is checked immediately for its feasibility. Order execution is undertaken according to the criteria of prices and order receipts, i.e., the first orders to be undertaken are those in which price terms are executable. Orders, which cannot be executed immediately, are transferred to the Order Book in the order of their validity.

The *Post Trading Phase* lasts at least one hour. During this phase, trading participants can use the EEX system in order to enter or access data. Participants can enter, amend and delete own orders, respectively. New entered orders will be considered in the succeeding day's trade. Furthermore, closed transactions can be processed.

Prices are set at the end of the Opening phase and during Continuous trading. The price determination is done by the system. All orders are categorised in the Order Book, firstly, according to price and, secondly, according to the time at which they were entered.

In order to determine the opening price, all orders are sorted in ascending order according to price. Generally, the opening price is the price from all valid orders at which the highest possible volume with minimum carry-over can be carried out (principally of most executable volume). If more than one price limit displays the highest executable volume and lowest surplus, then the surpluses are used as a criterion. If the surplus for all limits is on the buy side (surplus of demand), the auction price is determined according to the highest price limit. If the surplus for all limits is on the sell side (surplus of supply), the auction price is stipulated according to the lowest price limit. If equal surpluses are on both sell and buy sides, the price limit closest to the reference price is chosen.

During Continuous trading, a new price is reached when opposing orders can be carried out. If an incoming order enters an Order Book with orders on the opposite side of the Order Book, the incoming order is executed according to the price/time priority at the reference price or the limit of the executable order of the opposite site. The more favourable of these two prices determines the execution of the incoming order. This price is announced as the last price. In case the price cannot be determined immediately after an order has been entered, the relevant orders are saved in the Order Book according to their validity and are announced.

For carrying out all clearing procedures, especially for the calculation of the margin to be deposited by each participant, a settlement price for each individual contract is determined for each trading day on the EEX Futures Market. The determination of the settlement price is carried out at the end of Main trading phase of the contract on all trading days. The settlement price is the last traded exchange price of the contract for the respective trading day when the settlement price does not correspond to the actual market situation. The management of the EEX may determine the settlement price using the "Chief Trader Procedure". Three qualified traders are thereby selected from all participants and they may be asked to name a fair value for the contract in question. The mathematical average of these three prices is determined to be the settlement price for the contract in question.

Besides the trading of Futures at the EEX, OTC-trading also occurs for forwards in Germany. Contrary to futures, forwards are usually settled physically. The trading is done there almost continuously during normal business hours.

## Analysis of Prices and Volume

Although considerable differences exist between the various products, one observes that, in general, future and forward prices for electricity in Germany contrarily to spot prices exhibit:

- No cycles;
- Lower volatility;
- Little mean reversion.

Figure 16 illustrates this for some selected forward quotes. The absence of cycles is, of course, due to the fact that the price developments of forwards for one given expiry date are considered here. The forward curve, which includes forward prices for different monthly or quarterly delivery dates at a given moment in time, shows on the contrary seasonal patterns. The lower volatility of the forward prices is related to the fact that the forwards itself are storable equities, since they may be purchased today and sold tomorrow, or next month. This also explains why little mean-reversion in these prices is observed. As for any storable equity, arbitrage opportunities would arise if the (discounted and risk-adjusted) product price does not follow a martingale process, i.e., a stochastic process where the observed value for today corresponds to the risk adjusted expected value for tomorrow (cf., e.g., Hull 2000).

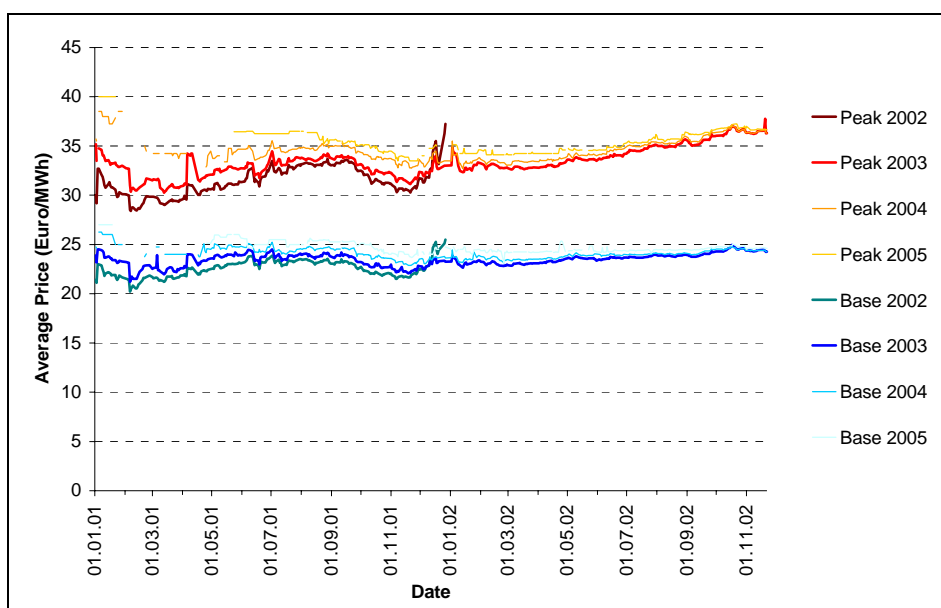

Figure 16: Electricity forward prices in (€/MWh). Source: broker quotes of various sources.

According to many analysts, the volume of OTC-trading in Germany is much higher than the EEX Futures trading. However, no precise figures can be given.

## 3.4 The German Regulating Power Markets

It is a well-known fact that electricity cannot be stored in any major quantities. This is why the amounts of electricity generated and consumed have to match exactly. Only this balance can ensure the reliable operation of the electricity system. In principle, this load-frequency control follows the regulations set by the UCTE. To maintain the balance of generation and consumption, the generation of power units that are connected to the UCTE network needs to be controlled and monitored. The generation control, the technical reserves and the corresponding per-

formance measurements are essential to allow TSO's to perform daily operational business. Control actions are performed in different successive steps, each with different characteristics and qualities, and all depending on each other:

- Primary control starts within seconds as a joint action;
- Secondary control replaces primary control after minutes by the responsible partner;
- Tertiary control frees secondary control by re-scheduling generation by the responsible partner.

Hence, a distinction is made between primary balancing power (primary control), secondary balancing power (secondary control) and minute reserve (tertiary control). They differ in terms of the activation and response speed. Primary and secondary balancing power are automatically called up by the TSO from controllable power plants. Primary balancing power must be fully provided within 30 seconds, while secondary balancing power has to be available within 5 minutes, as required. Requests of the TSO for minute reserve are communicated by telephone to the respective supplier. When secondary balancing power is required for longer periods of time, minute reserve is especially used after power plant losses to replace secondary balancing power and release it to meet new balancing needs. Minute reserve is always used as schedule delivery based on full quarters of an hour and must, therefore, be capable of being completely activated within 15 minutes. All these control qualities are traded in Germany in open regulating power markets (RPM). The control qualities are described in greater detail in a glossary at the end of this chapter.

### General Structure of the RPM in Germany

Due to different reasons, the TSO's in Germany, RWE Net AG, E.ON Netz GmbH, EnBW Transportnetze AG and Vattenfall Europe Transmission GmbH, established their own mainly Internet-based RPM to procure the various types of balancing power by way of competitive tendering in the deregulated power market. The markets were gradually established in February 2001 (RWE), December 2001 (E.ON), August 2002 (EnBW) and September 2002 (VE). While tendering for primary and secondary balancing, power reserve takes place every six months. Tendering for minute reserve is carried out every day. The used tendering model is schematised in Figure 17. The main characteristics of the RPM for primary, secondary and minute reserve are summarised in Table 4, Table 5 and Table 6, respectively.

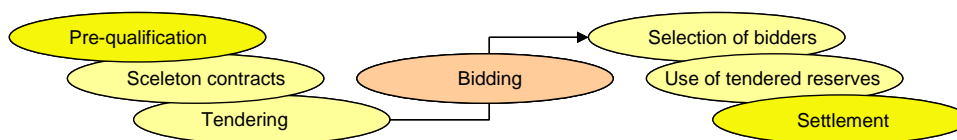

Figure 17: Schematised tendering model of the RPM in Germany.

Table 4: Main characteristics of the RPM for primary reserve in Germany (Dated 10.2003).

	RWE Net AG	E.ON Netz GmbH	EnBW Transportnetze AG	Vattenfall Europe Transmission GmbH
<b>Trading time</b>	biannual (Feb-Jul & Aug-Jan)	biannual (Jun-Nov & Dez-Mai)	biannual (Feb-Jul & Aug-Jan)	biannual (Mar-Aug & Sep-Feb)
<b>Total capacity asked</b>	+310 MW / -310 MW	+190 MW / -190 MW	+ 75 MW / - 75 MW	+150 MW / -150 MW
<b>Min. capacity to offer</b>	+ 2 MW	+ 10 MW	+ 10 MW	+ 10 MW
	L, P <sub>LP</sub>	L, P <sub>LP</sub>	L, P <sub>LP</sub>	L, P <sub>LP</sub>
<b>Offer characteristics</b>	only working day / weekend possible	Peak-/Base-Periods <sup>1)</sup>	only working day / weekend possible	only working day / weekend possible
<b>Time to guarantee reserves</b>	At least 6 hrs.	Whole offer period	At least 6 hrs.	At least 4 hrs.

<sup>1)</sup>  
Peak-Periods: Mo-Fr: 6 am  
to 10 pm, Sa, So: 8 am to  
1 pm; Base-Periods: else

Table 5: Main characteristics of the RPM for secondary reserve in Germany (Dated 10.2003).

	RWE Net AG	E.ON Netz GmbH	EnBW Transportnetze AG	Vattenfall Europe Transmission GmbH
<b>Trading time</b>	biannual (Feb-Jul & Aug-Jan)	biannual (Jun-Nov & Dez-Mai)	biannual (Feb-Jul & Aug-Jan)	biannual (Mar-Aug & Sep-Feb)
<b>Total capacity asked</b>	+1230 MW / -1230 MW	+800 MW / -400 MW	+ 720 MW / - 390 MW	+ 580 MW / - 580 MW
<b>Min. capacity to offer</b>	+ 30 MW	+ 30 MW	+ 30 MW	+ 20 MW
	L, P <sub>AP</sub> , P <sub>LP</sub>	L, P <sub>AP</sub> , P <sub>LP</sub>	L, P <sub>AP</sub> , P <sub>LP</sub>	L, P <sub>AP</sub> , P <sub>LP</sub>
<b>Offer characteristics</b>	Peak-/Base-Periods <sup>2)</sup>	Peak-/Base-Periods <sup>1)</sup>	Peak-/Base-Periods <sup>3)</sup>	Peak-/Base-Periods <sup>3)</sup>
<b>Time to guarantee reserves</b>	At least 4 hrs.	Whole offer period	At least 4 hrs.	At least 4 hrs.

<sup>1)</sup> Peak-Periods: Mo-Fr: 6 am  
to 10 pm, Sa, So: 8 am to  
1 pm; Base-Periods: else

<sup>2)</sup> Peak-Periods: Mo-Fr: 6 am  
to 10 pm, Sa, So: 8 am to  
1 pm; Base-Periods: else

<sup>3)</sup> Peak-Periods: Mo-Fr: 8 am  
to 8pm; Base-Periods: else

Table 6: Main characteristics of the RPM for minute reserve in Germany (Dated 10.2003).

	RWE Net AG	E.ON Netz GmbH	EnBW Transportnetze AG	Vattenfall Europe Transmission GmbH
<b>Trading time</b>	daily	daily	daily	daily
<b>Total capacity asked</b>	+1030 MW / -760 MW	+1100 MW / -400 MW	+ 510 MW / - 330 MW	+ 730 MW / - 530 MW
<b>Min. capacity to offer</b>	+ 30 MW	+ 50 MW	+ 30 MW	+ 30 MW
	L, P <sub>AP</sub> , P <sub>LP</sub>	L, P <sub>AP</sub> , P <sub>LP</sub>	L, P <sub>AP</sub> , P <sub>LP</sub>	L, P <sub>AP</sub> , P <sub>LP</sub>
<b>Offer characteristics</b>	5 offer periods <sup>1)</sup>	Peak-/Base-Periods <sup>2)</sup>	Peak-/Base-Periods <sup>3)</sup>	6 offer periods <sup>1)</sup>
<b>Time to guarantee reserves</b>	At least 4 hrs.	Whole offer period	Whole offer period	Whole offer period
<b>Selection of bidders</b>	P <sub>LP</sub>	P <sub>LP</sub>	P <sub>LP</sub>	P <sub>LP</sub> and P <sub>AP</sub> (Optimization)
<b>Remuneration</b>	Pay-as-bid	Uniform pricing	Pay-as-bid	Pay-as-bid
<b>Market open until</b>	Day-ahead, 2 pm <sup>4)</sup>	Day-ahead, 10.30 am <sup>4)</sup>	Day-ahead, 1.30 pm <sup>4)</sup>	Day-ahead, 9 am <sup>4)</sup>
<b>Decision of selection</b>	Day-ahead, 6 pm <sup>4)</sup>	Day-ahead, 11.30 am <sup>4)</sup>	Day-ahead, 2.30 pm <sup>4)</sup>	Day-ahead, 10 am <sup>4)</sup>

<sup>1)</sup> 0 am to 4 am, 4 am to 8  
am, 8 am to 4 pm (RWE),  
8 am to 12 am and 12 am  
to 4pm (VE), 4 pm to 8  
pm, 8 pm to 12 pm

<sup>2)</sup> Peak-Periods: Mo-Fr: 6 am  
to 10 pm, Sa, So: 8 am to  
1 pm; Base-Periods: else

<sup>3)</sup> Peak-Periods: Mo-Fr: 8 am  
to 8pm; Base-Periods: else

<sup>4)</sup> Trades only on weekdays

### **Pre-Qualification**

Potential suppliers of the various types of balancing power can participate in a pre-qualification procedure by which the technical capabilities of the generation units or customer-based facilities to be used for the supply of balancing power are reviewed by the TSO. Following successful pre-qualification, the supplier is entitled to participate in the tendering procedures.

### **Skeleton Contracts**

The commercial and administrative outline conditions are defined in master agreements before the first bid can be submitted.

### **Tendering**

Tendering for minute reserve is Internet-based. All the communication with the respective bidders, such as submission of bids and information about the award decision, takes place in a secure portal. General market information, including an anonymous presentation of the bids and award decision, is available in a public area. The market processes, such as tendering, deadlines, award processes, are largely automatic. Tendering for primary and secondary balancing power is not conducted across the Internet, but in a conventional manner mainly because these contracts are awarded over longer periods of time.

The RPM in Germany are designed to be one-sided, multi-unit and multi-part procurement auctions. They are one-sided as a market participant can either offer or ask for reserves (in contrast to the double auction design of the spot market). Multi-unit refers to the fact that more than one reserve unit is auctioned at the same time. Multi-part reflects the important fact that each offer for secondary and minute reserve is based on two-price information, the capacity and the energy price. Primary reserve is traded based on energy price offers only. The capacity price is paid for holding the selected capacity in reserve (it is not allowed to use this capacity for any other purpose) and the energy price is paid only if the reserved capacity is actually used. Each reserve capacity is procured in positive and negative direction. Positive reserve is required to balance a shortfall of required capacity and negative to balance a surplus. The tendering described so far is similar at each RPM. However, the rest of the tendering process is quite different, cf. Table 4, Table 5 and Table 6. Some of these differences are discussed in the following paragraphs.

### **Bidding**

When bidding, a market participant will determine his offers with respect to profit maximising. As there are four markets, the bidder needs to determine the offer prices and capacities for each market separately. For this, several aspects need to be considered, mainly (1) minimum capacity to offer, (2) different offer periods, (3) time to guarantee the reserves and (4) different times of market opening and closing.

### **Selection of Bidders**

The bids are examined on the basis of commercial and technical criteria. It is essential that sufficient balancing power is available at all times for contracts to be awarded during the award period and that system security is ensured. Currently, only daily averaged capacity prices and the minimal and maximal energy prices are published separately for positive and negative reserves by the TSO. Hence, no hourly or segment-specified prices as well as no volume is available. However, the market participants have information based on their own offers so that they might be able to reason the possible range of market prices.

### **Use of tendered reserves**

The tendered reserves are used with increasing energy price (merit order) to maintain the balance of generation and consumption.

### **Settlement and Remuneration**

As described earlier, offers are based on a capacity price for holding the procured capacity in reserve (secondary and minute reserve) and an energy price for the actual use of the procured capacity (all reserve qualities). In principle, two possibilities exist to remunerate the suppliers. Firstly, by using the pay-as-bid method, bidders receive their individual bid prices. Secondly, by using the uniform-price method, bidders receive a uniform price based on the highest accepted bid.

The settlement may be differentiated between power and energy related costs. The power related costs are socialised among all system users via usage fees. The energy related costs are individualised among balance responsible entities (net deviations from planned programmes of balance groups are valued).

### **Analysis of Prices and Volume**

The daily averaged RPM capacity and minimal and maximal RPM energy prices for positive minute reserve are given in Figure 18 and Figure 19, respectively. It may be seen that the prices are similar to the spot market ones that are characterised by:

- Daily and weekly cycles;
- High volatility;
- Spikes.

The volatility and spikes of the capacity and energy prices increased considerably, especially within the last few months. This was mainly due to the unforeseen weather characteristics with high temperatures, few water in-flow to the pump storage plants and low wind power production. This led to high volatility price spikes at the spot market and hence at the RPM. It is worth noting that the volatility at the E.ON market is lower compared to the RWE or EnBW RPM. This is mainly due to the different closing hours of the market, where the offers are only placed at the E.ON RPM without information concerning the spot market price of the same day. Generally, the RPM for positive minute reserve does not show mean reversion as known from most spot markets. On the contrary, a tendency to remain on a reached price level may be observed (especially in 2001 and 2002). This tendency supports the possibility of having an imperfect market.

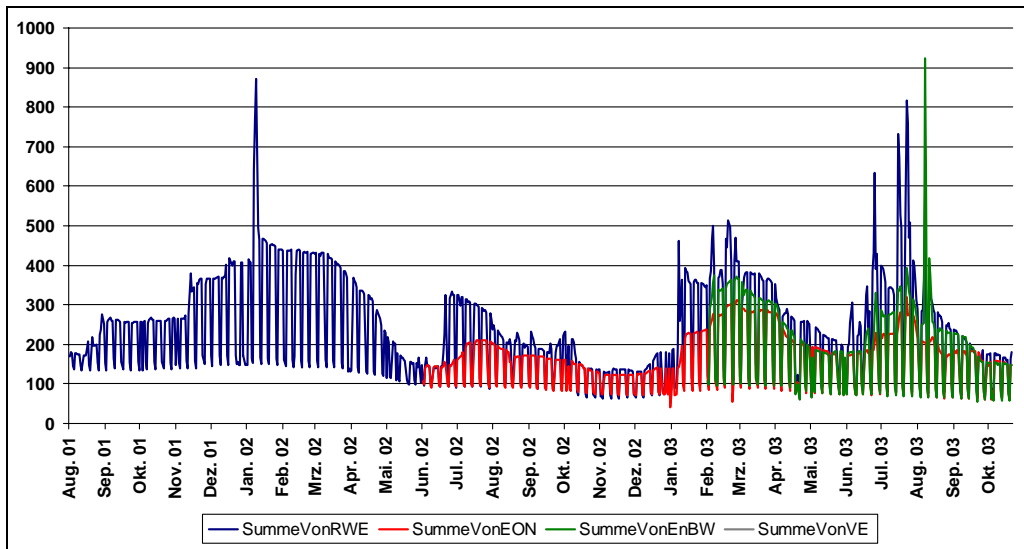

Figure 18: Daily averaged hourly RPM prices for positive minute reserve in (€/MW).

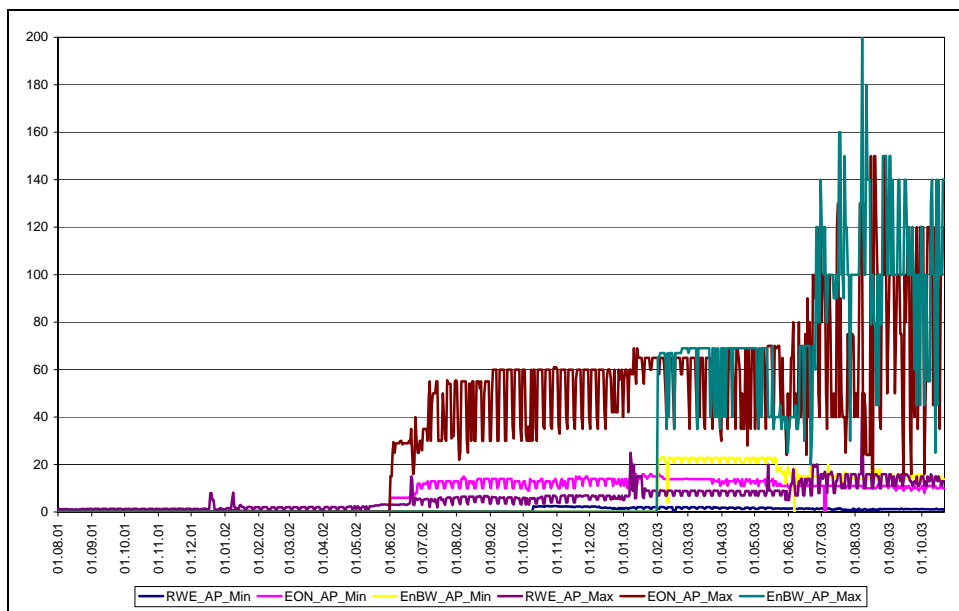

Figure 19: Minimal and maximal RPM energy prices for positive minute reserve in (€/kWh).

The overall accepted bidders averaged RPM capacity prices for primary reserve are given with Figure 20. Compared to minute reserve, the prices are considerably higher. This may partly be explained with the oligopolistic structure of the market for primary reserve and on the fact that much higher technical requirements need to be fulfilled by the power plants to be allowed to deliver primary reserve. It may be seen that there are (again) relatively high deviations between the markets with a tendency to higher convergence within the last months.

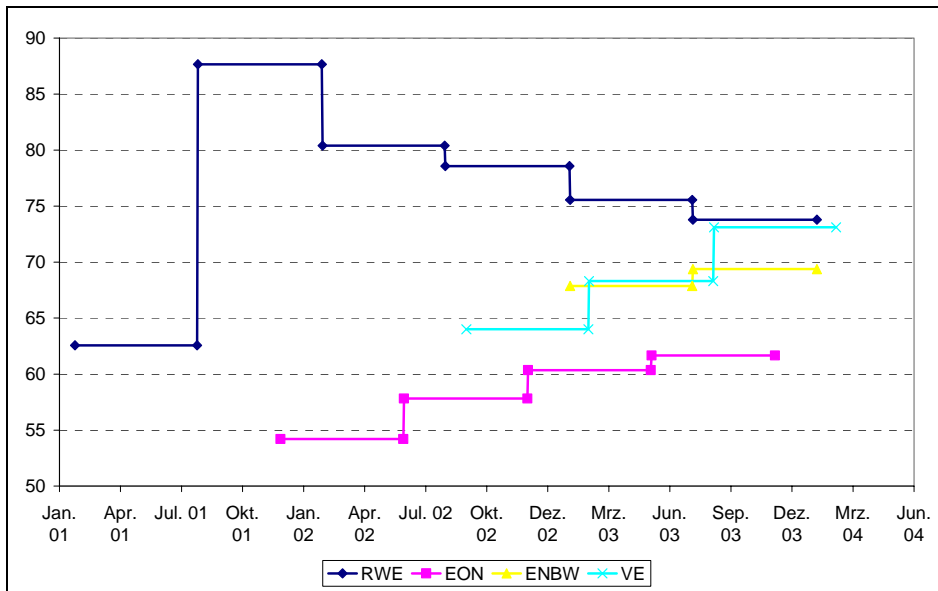

Figure 20: Averaged RPM capacity prices for primary reserve in (€/kW).

The overall accepted bidders, averaged RPM capacity prices and minimal energy prices for positive secondary reserve are given in Figure 21 and Figure 22, respectively. The capacity prices are lower compared to primary and higher compared to minute reserve, due to lower technical requirements compared to primary reserve and higher ones compared to minute reserve. The observed differences between the markets are not as great as in primary RPM, which may lead to the suggestion that the secondary RPM is based on higher competition with higher trading volume (however, this suggestion cannot be approved as no information on the offered volumes are published). The energy prices are extremely low compared to the energy prices for minute reserve, and even though the maximal values are not given in the figure, it may be noted that they do not deviate as much from the given minimal ones as in the minute RPM. This may be explained with the higher portion of power plants with relatively high variable costs (e.g., open cycle gas turbine, OCGT) offered in the minute reserve rather than in the secondary reserve markets.

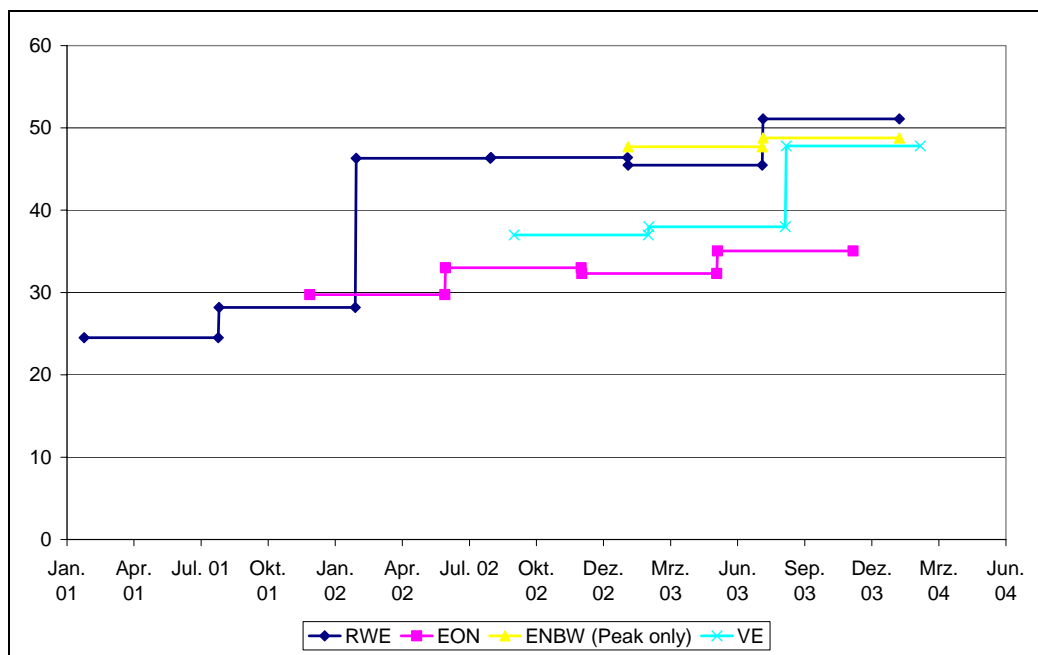

Figure 21: Averaged RPM capacity prices for positive secondary reserve (€/kW).



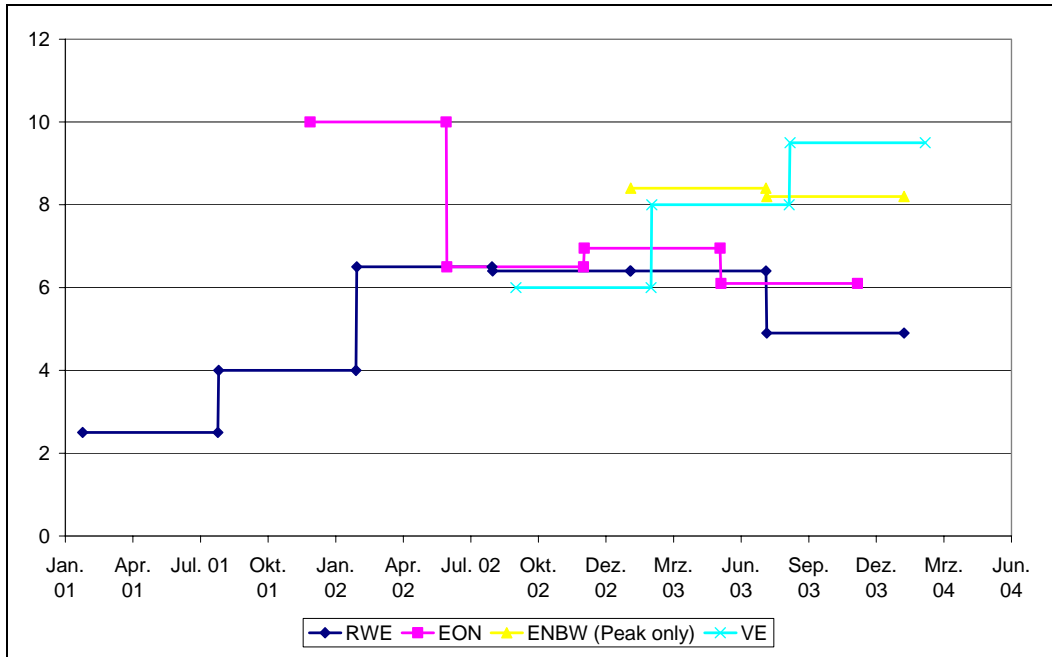

Figure 22: Minimal RPM energy prices for positive secondary reserve in (€/ct/kWh).

## 4 Models

A qualitative description of the power market models used in Wilmar is given in this chapter, although the mathematical presentations of the models have been omitted and will be treated in a later publication from the project.

The intention of the section is not to give a full documentation of the Planning model, but to describe the ideas and assumptions behind the representation of the power markets to be included in the modelling tool. Full documentation of the Planning model will be given in Deliverable D6.2 to be published at a later stage of the project. In the following therefore first an overview of different approaches to modelling power markets and electricity prices is given in section 4.1, then the general approach chosen in the WILMAR project is discussed in section 4.2 and 4.3. The main model components, being the long-term model and the joint market model, are discussed in Sections 4.4 and 4.5, respectively.

### 4.1 Modelling Power Markets and Electricity Prices

In the past, various approaches have been developed to analyse and predict power markets and resulting electricity prices. They may be broadly divided into at least five classes (cf. Table 7). Among the theoretically founded models, fundamental models are allowed to account well for the impact of power plant characteristics and capacities, for restrictions in transmission capacities and demand variations. The financial mathematical models are more suited for coping with the volatility of electricity prices and are often used for option valuation and risk assessment purposes. A third category of models is formed by game-theoretic approaches, which are particularly adequate for analysing the impact of strategic behaviour on electricity prices.

Besides these models with strong theoretical foundations, other more empirically motivated models are found: The fourth class of models, statistical and econometric time-series models, relate the fluctuations of electricity prices to the impact of external factors such as temperature, time of the day, luminosity, etc. The stochastic aspect of electricity price formation is acknowledged here albeit often not dealt with in much detail. In fact, this type of model is very complimentary to finance models, in that the statistical and econometric models deal in detail with possible explanatory variables for electricity price fluctuations whereas the finance models focus on the stochastic part of the price change. All the above-mentioned models will all be treated in more details in the following sections of this paper.

Finally, so-called “technical” analysis and expert systems can also be mentioned as methods used especially by practitioners to anticipate price movements on power markets based on the analysis of past price developments. This category of modelling will not be treated in this paper. Instead, Section 4.4 sketches a novel integrated model combining the two aforementioned approaches of fundamental and financial models.

Table 7: Types of power market models

Model Category	Examples
<b>Theoretically Founded Models</b>	
Fundamental models	Kreuzberg (1999), Starrmann (2000), Müsgen, Kreuzberg (2001), Ravn et al. (2001), Kramer (2002)
Finance models	Pilipovic (1998), Schwartz (1997), Johnson, Barz (1999), Barlow (2002)
Game theoretical models	Green, Newbery (1992), Bolle (1992), Bolle (2001), Jebjerg, Riechmann (2001), Weber (2001)
<b>Empirically Motivated Models</b>	
Statistical models	Erdmann, Federico (2001)
“Technical” analysis and expert systems	

### Fundamental Models

The basic idea of fundamental models is to analyse power markets based on a description of generation, transmission and demand, combining the technical and economical aspects. These models often aim at also explaining electricity prices from the marginal generation costs. Examples of such models include Kreuzberg (1999), Starrmann (2000), Müsgen, Kreuzberg (2001), Ravn et al. (2001), Kramer (2002), Kurihara et al (2002) and ILEX (2003). Many more fundamental models have been developed by consultants or the utilities themselves and are, therefore, not published. Fundamental models are often also incorporated in more sophisticated game theoretic (Jebjerg, Riechmann 2000, Ellersdorfer et al. 2000, Hobbs et al. 2002) or stochastic models (Skantze et al. 2000, Barlow 2002). However, in the latter papers, continuous approximations to the fundamental electricity price formation are especially used.

The basic assumption of fundamental models is that the electricity spot market operates efficiently, so that it leads to an efficient system operation with minimal costs, satisfying all customer demands. If customer demand is taken as price inelastic (and there is much evidence of almost price-inelastic demand, cf., e.g., the figure for Alberta given in Barlow 2002), prices will equal to the marginal generation costs of the last unit needed to fulfil given demand. This result of price formation according to the merit order curve is graphically illustrated in **Figure 23**.

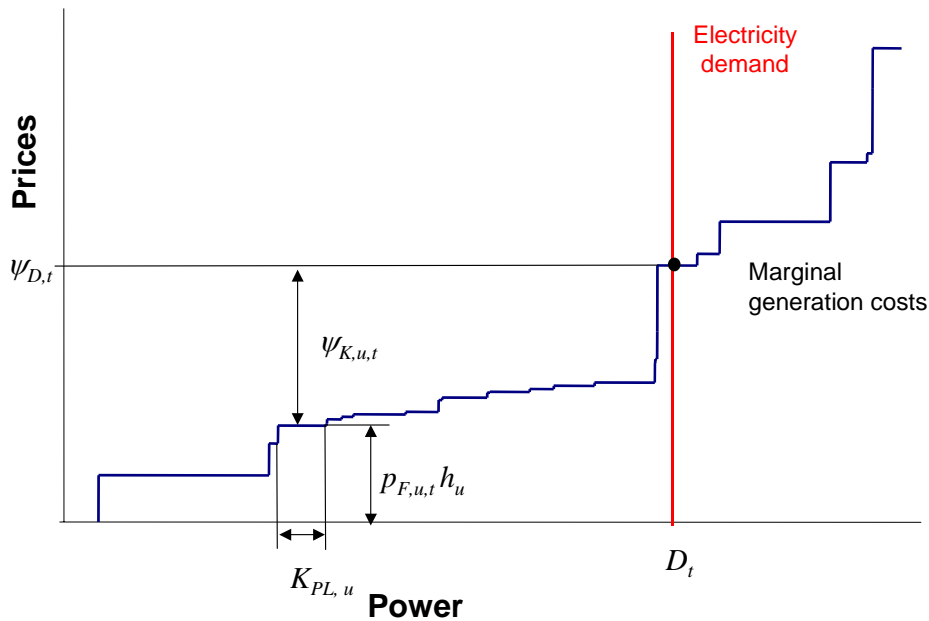

Figure 23: Merit order and shadow prices in the simple cost minimisation model.

Of course, this is only a very basic model, which has to be extended into several directions in order to at least cope to some extent with the reality in European electricity markets. A first extension to be considered is multi-regional modelling. Since transmission capacities between countries and within countries are often limited, those have to be included in an optimisation model, which describes the cost minimal provision of electricity demand.

Besides the often-focused on thermal power plants, hydro power plants also play a considerable role in many electric power systems, including the European one. At least three cases here have to be distinguished: Run-of-river plants, Hydro storage plants and Hydro storage plants with pumping facilities (pumped storage plants). Notably, the storage plants require a modelling approach, which encompasses several times steps and possibly stochastic inflows, such as in the EMPS model.

Furthermore, start-up costs may considerably influence the unit commitment decisions of plant operators. In unit commitment and load dispatch models, they are typically modelled using binary variables for unit operation, start-up and shut down. But this is hardly feasible when modelling a national or regional market. Weber (2003) has, however, provided an approximate approach for dealing with part-load efficiencies and start-up costs.

A further point to be considered is the different types of reserves, which have to be provided by the generators. A rather detailed model of the different cases for the German market can be found in Kreuzberg (1999).

For the practical implementation of any such fundamental model, three major challenges arise. The first one is data availability. Depending on the market, more or less information on plant capacities and costs, demand patterns and transmission capacities may be available to construct such a model. A second challenge is the choice of appropriate time resolution. On the one hand, the modelling of seasonal hydro storage necessitates the modelling of a full year. On the other hand, the adequate modelling of start-up costs requires a time resolution of one hour, or at most two. In order to keep the model manageable, one solution is to model typical days, as will be done within the framework of the integrated model (cf. Section 4.4). An-

other is to use load segments within a seasonally decomposed yearly model (cf. Kreuzberg 1999). In this framework, the integration of start-up costs is, however, difficult.

A final challenge is the incorporation of stochastic fluctuations, e.g., in demand or plant availability. This is particularly relevant, if the model is to be directly used for short-term predictions (time horizon of up to two weeks). At longer time horizons, the impact of current values of the stochastic variables on the future prices is rather limited, as can be both explained fundamentally (stability of weather conditions, duration of plant outages) and observed empirically (cf. Section 0). Of course, it is in principle also possible to model all fundamental stochastic fluctuations fundamentally, by carrying out, e.g., Monte-Carlo-simulations of demand variations, plant outages, etc. But even if these processes could be perfectly modelled bottom-up, one should not expect to describe the full range of fluctuations observed on the markets: As demonstrated for the financial markets (cf. Hull 2000), trading itself is expected to contribute to the creation of stochastic fluctuations.

### **Finance and Econometric Models**

The field par excellence of the numerous models developed in finance describes the stochastics of price movements. Originally developed for stock and interest rate markets, quite a number of these models have also subsequently been applied to the energy field. Econometric models have also to be dealt with in this paragraph, since there is considerable overlap between these two categories. The key emphasis of econometric models is on the inclusion and specification of deterministic regressors. Yet, given the specificities of electricity, notably its non-storability, not only specific models for the deterministic term have to be considered, but also the stochastics may be more adequately modelled by more advanced models.

At the beginning, price movements on the wholesale markets for electricity and other energy carriers have been described using models originally developed for modelling the stock and interest rate markets, and even today, the geometric Brownian motion is still used frequently to describe electricity market prices on the forward and future markets. Another popular model is the so-called mean-reversion process, which account for the tendency of electricity prices to return to some average equilibrium value. Another extension is the jump-diffusion processes, which more specifically cope with the price spikes that are observed in many power markets.

Besides the specification of the stochastic structure, any spot market model for electricity has to account for the cyclical, more or less deterministic effects, which are observable in spot market prices. Three different types of cyclical effects can be distinguished: hour-of-the-day effects, day-of-the-week effects and seasonal effects. For all three, one of the following approaches could, in principle, be applied:

- Inclusion of continuous variables;
- Inclusion of corresponding dummy variables;
- Distinction of separate models.

For example, Pilipovic (1998) uses sinus and cosinus functions to model seasonal effects, whereas Cuaresma et al. (2003) include monthly dummies to make the equilibrium price  $p_0$  in the specifications time-dependent. Lucia and Schwartz (2000) test both specifications. Although monthly dummy variables seem at first sight to be more accurate, they are problematic when it comes to forecasting beyond the limits of one month: a sudden change in the time varying mean (estimated

from the observed data) may induce a sudden price shock, which is amplified through the mean-reversion process.

For the hour-by-hour variations, Cuaresma et al. (2003) tests both a specification with dummy variables and a distinction of separate models as proposed by Ramathanan et al. (1997). They find clear evidence that a distinction of different models leads to a higher model quality.

Overall, finance and econometric models are of considerable importance when it comes to analysing the characteristics of electricity prices, but they obviously do not tell much about the generation technologies used for power production or the adequacy of supply and demand.

### **Modelling Competition in the Electricity Industry**

Besides price uncertainty, the strategies of the competitors also affect the decisions of electric utilities. Models of competitive electricity markets with explicit actor modelling have to date been mostly developed to analyse longer-term equilibrium on the wholesale market.

In general, two types of approaches have been used to model the competition on the wholesale market. The first one is using the Cournot-Nash framework (cf., e.g., Andersson / Bergmann, 1995; Borenstein et al., 1999; Ellersdorfer et al., 2001, Ellersdorfer et al., 2003 (see also the overview in Smeers, 1997). Underlying are the assumptions of electricity as a homogenous good and of market equilibrium being determined through the capacity setting decisions of suppliers. This model type is, however, only appropriate for the description of the medium to long-term equilibrium determination. Namely, the existence of Nash equilibrium in this modelling framework requires substantial negative own price elasticity for electricity. While most empirical studies (e.g., Dennerlein 1990, Dahl 1994) agree that significant negative own price elasticities exist for electricity in the longer run, both empirical studies and most practitioners agree on the electricity price elasticity to be negligible for the short run or even non-existent.

The second one is modelling the price equilibrium on the wholesale market as the equilibrium of companies bidding with supply (and possibly demand curves) into the wholesale market. Klemperer and Meyer (1989) and Green and Newbery (1992) developed the first models that used this approach. Further models in this vein include Bolle (1992), Bolle (2001) and Hobbs (2001). As emphasised by Bolle (2001), supply curve bidding will only lead to results different from traditional Cournot-Nash equilibria, if demand uncertainty (or another source of uncertainty) leads to an ex-ante undetermined equilibrium. Otherwise, the supply (and demand curve) bidding collapses to one point, which corresponds to the Cournot-Nash equilibrium. Recent work in this field has on the one hand looked in more detail at the role of capacity constraints for strategic price equilibria (cf., e.g., von der Fehr, Harbord 1997; Baldick, Hogan 2002; Crampes, Creti 2002). On the other hand, numerous models have been set up to analyse the interactions between grid restrictions and market power for suppliers (e.g., Harvey, Hogan 2000, Hobbs et al. 2000, Gilbert et al. 2002, Metzler et al. 2003). Furthermore, recent research has emphasised the role of a contract market for future and/or forward contracts for mitigating market power in electricity markets (cf., e.g., Newbery 1998, Ellersdorfer 2003).

Three points seem particularly worth retaining from this vast literature: Most of the models developed are focusing on qualitative issues, taking quantitative results more as illustrative examples than as ultimate research objective. This is linked to the second observation that most analyses aim at providing decision support more

to the regulators than to the utilities. The third point is that in most analyses, the entire focus is on the wholesale market and that the interlinkage between wholesale and retail markets are hardly analysed so far.

### An Integrated Modelling Approach

The previous discussion on fundamental and financial models for electricity market modelling has pointed at the relative strengths and weaknesses of both approaches. In particular, the case for pure financial models is weakened by the fact that the non-arbitrage argument underlying many financial model developments can hardly be applied to electricity prices. Instead, a time series of electricity spot prices has to be viewed as a series of consecutive, but only partly linked market equilibria. These market equilibria may be computed (approximatively at least) through fundamental models – but these have huge difficulties in describing the stochastics observed in the electricity market. Therefore, Weber (2003a, 2003b) has proposed an integrated model, which combines fundamental and finance type models. More precisely, it uses the price established by a fundamental model as equilibrium price for a mean-reversion stochastic model.

The overall approach for this integrated model of electricity markets is sketched in Figure 24. In a first step, the stochastic development of prices on the primary energy market is modelled through a finance-type model. The resulting energy prices are taken as an input to a fundamental model of the European electricity market. This model yields marginal generation costs differentiated by time of the day, type of day and month in the year. These prices could be used as an input to a game-theoretic model yielding the prices and mark-up charged by strategic players in the market. However, such a model is not easy to solve in the proposed context. Therefore, the system marginal costs are directly used as an input for a stochastic model of the electricity market.

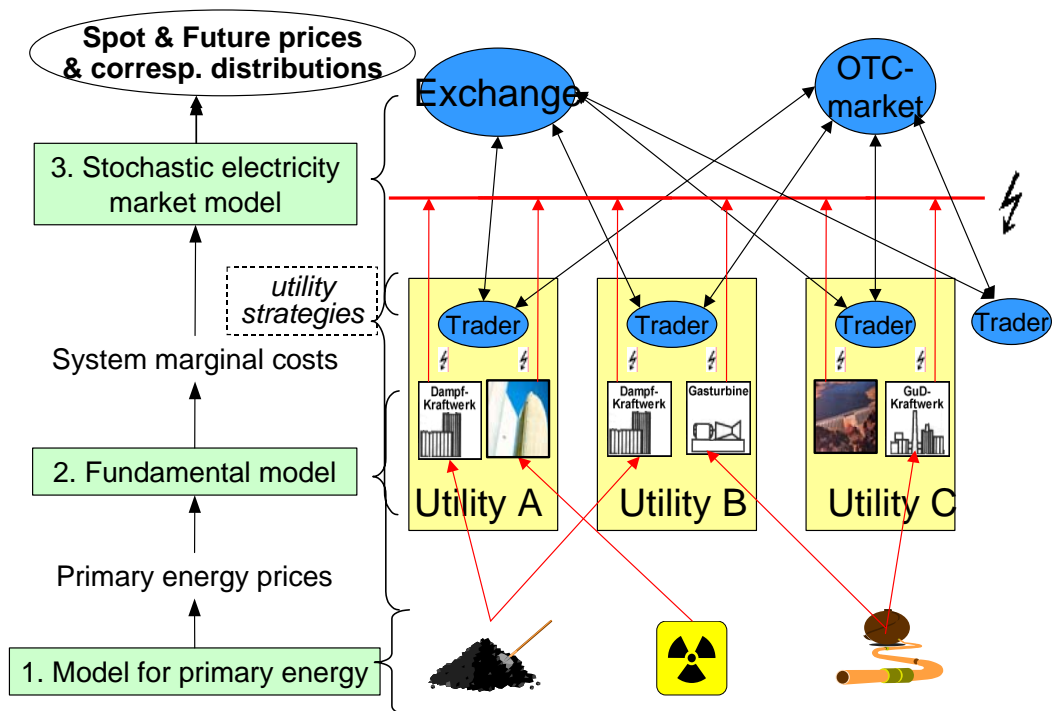

Figure 24: General approach for the integrated electricity market model.

## 4.2 General Modelling Assumptions

### Number of Markets for Physical Delivery of Electricity

Three electricity markets are included in the Planning model, namely:

1. A day-ahead market for physical delivery of electricity where the Elspot market at Nord Pool is taken as the starting point<sup>9</sup>. This market will in the following text be called the **day-ahead market**.
2. An intra-day market for handling deviations between production and consumption agreed upon on the day-ahead market and the realised values of production and consumption in the actual operation hour. Regulating power can be traded up to the start of the actual operation hour. Hourly mean-values are used meaning that there is no inter-hour regulation happening in the model. Both flexible producers and flexible consumers offer regulating power on this market, which in the following text is called the **intra-day market**. The demand for regulating power is defined by the forecast errors connected to the wind power production.
3. A day-ahead market for automatically activated reserve power (frequency activated or load-flow activated). The demand for these ancillary services is determined exogenously to the model. This market will be called the **ancillary services market**.

Descriptions of the day-ahead markets and the intra-day markets functioning at Nord Pool and EEX at present are given in Chapters 2 and 3. Over-the-counter/bilateral trading of physical power contracts will not be included in the model, because the power prices of the bilateral contracts will in a perfect market reflect the expected prices on the day-ahead market, and the inclusion of OTC trading will, therefore, have little impact on the model results.

Finally, the day-ahead and intra-day power markets will cover the whole geographical area, i.e., we assume that the day-ahead market at Nord Pool and EEX can be analysed as one market<sup>10</sup>, and the same applies to the intra-day market.

### Other Markets Represented in the Model

Three further markets are taken into account that influence and may interact with the above markets. These are markets for:

- District-Heating and Process Heat;
- Tradable Green Certificates (TGCs);
- CO<sub>2</sub> quotas and Tradable CO<sub>2</sub> Emission Permits (TEPs).

The markets for district heating and process heat is included in the Planning model, because they interact with the day-ahead and intra-day markets due to the existence of CHP plants, electrical heat pans and heat pumps.

The TGC market and TEP market influence the functioning of the power system through changing marginal cost levels for actors bidding at the day-ahead and in-

---

<sup>9</sup> The model must enable changes in the spot market trading rules such as a change from a day-ahead market to an hour-ahead market.

<sup>10</sup> Although we assume one market covering the whole geographical area, this does not imply that we will only have one market price in the whole area. Exchange restrictions between areas will result in different area prices.



tra-day markets. The income or costs from TGC's and TEP's change the relative competitiveness among actors when allocating bids at the power markets.

It remains to be decided on how to represent these markets in the model. The TGC market will only influence the day-ahead market bidding of generating plants using renewable energy sources, i.e., wind power, photovoltaics, waste power and biomass power. Of these technologies, only biomass power has significant short-term marginal generating costs<sup>11</sup>. The reduction in the day-ahead market bidding price due to the existence of a TGC connected to the electricity production will, therefore, probably only have a significant influence on biomass power. A market for green certificates may be exogenous to the model.

There are two different ways of representing CO<sub>2</sub> quotas in the model:

1. Assuming a fixed quota for the North European electricity system and using a long-term model to optimise the CO<sub>2</sub> emissions during a year. The result will be an endogenous determination of the CO<sub>2</sub> shadow price.
2. The North European electricity system can be assumed to be a price taker on a larger European-wide market for CO<sub>2</sub> emission permits. The result will be that the CO<sub>2</sub> shadow price in the model will be exogenous and equal to the price on the large CO<sub>2</sub> TEP market.

Both possibilities are easy to implement in the Planning model and will, therefore, be available according to the purpose of the model simulations.

### Short-Term Marginal Pricing

We assume perfect competition where power suppliers offer electricity to the **short-term marginal cost of generation** of the power plants. This assumption covers both the day-ahead and the intra-day market. For a given power plant, the short-term marginal cost of generation covers the price of the fuel input and the variable operation and maintenance costs, including start/stop costs. Investment costs and fixed operation and maintenance costs are not included in the short-term marginal costs.

Using sale bids based on the short-term marginal cost of generation will in some cases result in power pool prices that are significantly below the historical day-ahead market prices observed on Nord Pool and EEX. To obtain a better correspondence between model results and historical realisations, an add-on to sales bids can be included in the model. One method of calculating the size of the sale bid adders is to estimate the capacity rent of the power plant in question, i.e., the annualised investment costs and the fixed operation and maintenance costs.

## 4.3 Modelling Framework

Figure 25 shows an overview of the models that either provide input to the Planning model or constitute the Planning model. The exchange of forecast data and data for the actual operating hour between models is illustrated in the figure. A number of models provide input to the Planning model as seen in the figure. The Planning model consists of two sub models corresponding to optimisation over two different time horizons.

---

<sup>11</sup> The present short-term marginal costs of waste power are very low, because the fuel input (the waste) has a price of zero or below zero (the plants are paid for burning the waste).

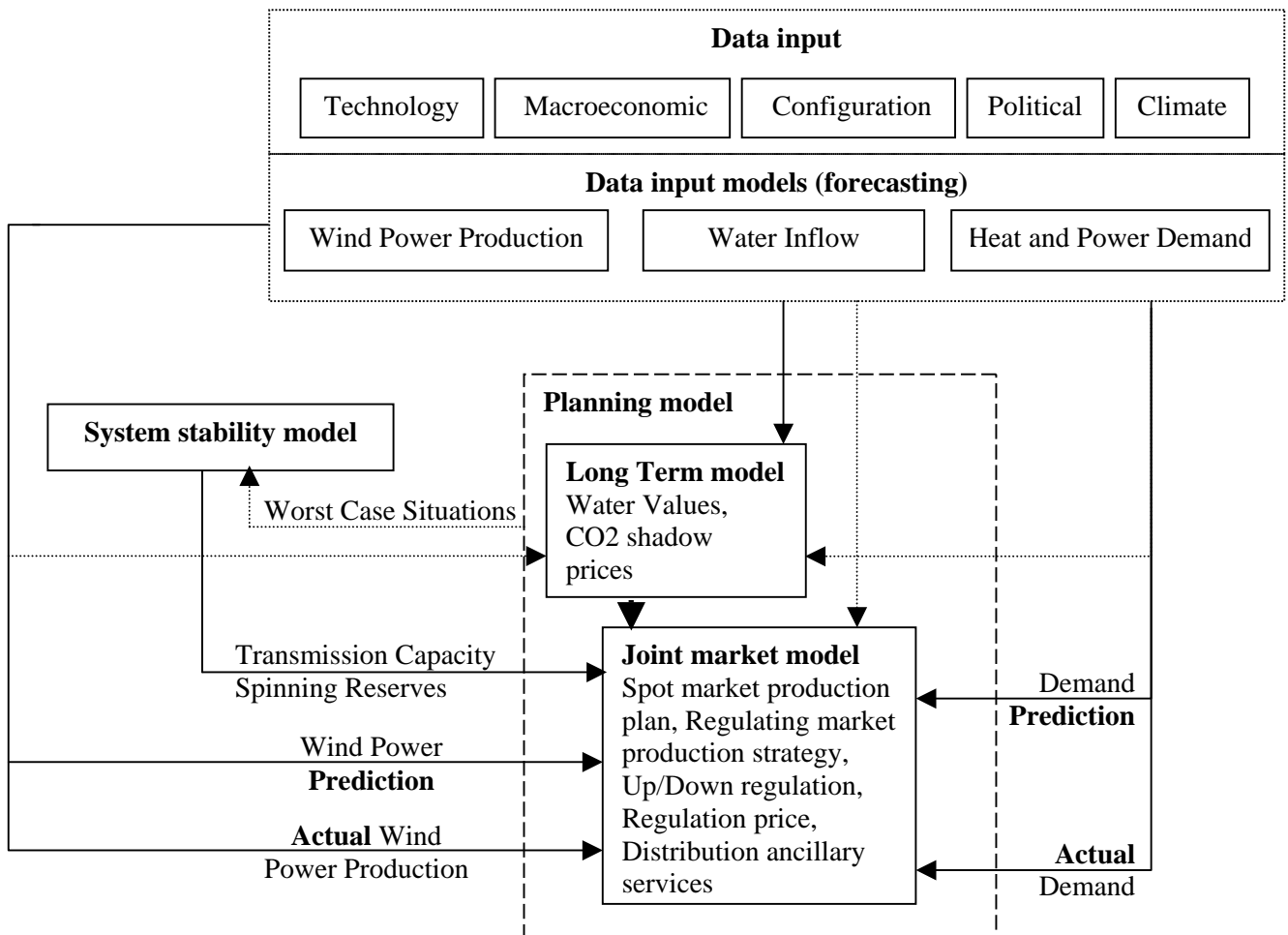

Figure 25: Overview of the data input and models that either provides input to the planning model or constitutes the planning model.

Due to the existence of hydro reservoirs and limitations on the amount of water inflow to the hydropower system, the use of hydropower must be optimised over a one-year (or longer) horizon. Furthermore, if we assume the existence in the model of a fixed CO<sub>2</sub> quota for the North European electricity system, the CO<sub>2</sub> emissions from the power plants will be subject to a long-term (yearly) restriction.

The Long-Term Model will optimise the use of water inflow and CO<sub>2</sub> quotas over a one-year horizon. The input from the long-term model to the Joint Market model will be one table with the water values (opportunity costs of using stored water) as a function of reservoir filling and time of year, and another table with the CO<sub>2</sub> shadow prices as a function of the fraction of the available CO<sub>2</sub> quota still not used and the time of year.

The Joint Market Model will optimise the use of heat and power generating technologies and heat and power storage technologies during a bidding period<sup>12</sup> subject to a flexible demand. More precisely, the model will optimise the sum of consumers' and producers' surplus on both the day-ahead market and the intra-day market (so-called joint optimisation) taking the stochastic nature of the demand for regulating power on the intra-day market into account. This means that for generating technologies with a flexible power output, the amount of power offered at the day-

<sup>12</sup> 24 hours for the present day-ahead market at Nord Pool with a 12-hour interval between submission of bids and start of the bidding period.

ahead market will not always be the maximal power output available, but they will sometimes offer less at the day-ahead market due to an expected revenue from the selling of up-regulation at the intra-day market.

Implementing joint optimisation in the Joint Market model means that the amounts and marginal costs of regulating power available in a future operating hour as a function of the regulation needs in the bidding period will be determined in the Joint Market model.

Furthermore, the Joint Market model takes into account that some part of the available production capacity must be reserved for providing automatically activated reserve power. The distribution of the demand for ancillary services on the power plants available for providing these services is done endogenously in the model by including this ancillary services market in the optimisation of consumers' and producers' surplus.

The Joint Market model will use water values and CO<sub>2</sub> shadow prices obtained from the Long-Term model and input from other models to determine the short-term marginal costs of different supply technologies. Two sets of short-term marginal costs can be thought of; one set for delivering power sold at the day-ahead market, i.e., where the future production is known at least 12 hours before delivery, and another set for up or down regulation delivered at the intra-day market, where the power output must be changed with one hour notice. Discussions in the project team involving ELSAM, the power plant operator, has revealed that these two sets of costs can be assumed equal, i.e., the extra costs connected to changing production fast are negligible compared to the modelling simplifications and data uncertainties connected to the representation of production costs in the Planning model.

Combined with the heat and power demand curves obtained from the heat demand and power demand models, and combined with forecasts of the amount of up or down regulation needed in the actual operating hours, the day-ahead market model for each operating hour in the bidding period determines production, consumption and prices on the day-ahead market. The demand for either up or down-regulation in each hour in the bidding period is calculated by comparing the forecasted values of wind power production and power demand (and maybe other parameters) with the realised values. Having determined the realised state, the results from the Joint Market model will determine how the units were actually operated during the day-ahead market period and the resulting prices on the intra-day market.

The market-crosses at the day-ahead and intra-day markets will determine the dispatch of the generating units and this will, in addition, determine the power flows in the system (the dispatch being modified in the presence of bottlenecks in the transmission grid). Furthermore, the market-crosses are based on a marginal cost approach, so the difference between the prices obtained at the day-ahead and intra-day markets and the marginal costs of a given unit will determine the profit of operating the unit in the electricity system.

## **4.4 Long-term Model**

The main subject of the Wilmar project is the integration of wind power into the electricity system. Hence, the focus is on short-term issues, typically working on an hourly basis.

However, in order to have a self-contained model, it will also be necessary to treat the longer-term aspects – primarily linked to the allocation of hydropower over the year. This is the issue of the long-term model.

This document describes the idea and present status of the development of the long-term model.

The traditional formulation of the hydro scheduling problem is as a staged stochastic optimisation problem, or as an optimal control problem. The stages are typically months or weeks. The dominant stochastic element is the hydro inflow, however, other components may be incorporated, in particular, wind power if large amounts of capacity is installed.

It is expected that for the Wilmar project, the week will be taken as the time step in the definition of the stages.

The development of the long-term model will be done in phases, starting **small** and improving. A one storage program is presently under development.

### **Present Implementation of the One Storage Program (the HYSP Module)**

The implementation is done within the Balmorel framework. It is expected that minor changes will be necessary in order to accommodate the program within the Wilmar model since the Balmorel model was used as starting point in the Wilmar project. All coding was done in the GAMS modelling language.

A standard backwards-stochastic dynamic programming method is applied. The basic time step is given by the seasons. It is assumed that the stochastic elements are the inflow to the hydro reservoirs, and that the inflows are independent between seasons. For each season, the decision on the quantity of hydropower production has to be decided before the observation of the stochastic inflow. However, it requires only minor changes in order to implement the version with decision after the observation.

The present implementation uses an approximation so that only one reservoir is considered, representing the total reservoir volume in the simulated countries. Hence the name 'HYSP' is used, to indicate 'HYdro Single Price' (or 'HYdro System Price' since the model was developed for the Nord Pool area where 'system price' indicates the electricity price that would apply if there were no transmissions limitations).

The aggregated reservoir is defined and analysed as follows. All hydro reservoirs in the simulated countries are aggregated to one reservoir with volume equal to the sum of the individual volumes. All hydro inflows are aggregated to one inflow equal to the sum of the individual inflows. All transmission capacities are set to infinity.

The next step is to calculate total system costs. The total cost is the sum of consumers' and producers' surplus. If demand were inelastic, the costs may be the total cost of production on all units except hydro units. These costs are calculated for a number of relevant quantities of hydro production in each season (month or week). The production levels are discretised using levels of equal distance *HYSPLMWH* (MWh).

A backward stochastic dynamic programming is now performed. For this reservoir, the volume is discretised into levels with equal distance *HYSPLMWH*. The stochas-

tic inflow is similarly discretised into equal levels of *HYSPLMWH*. The stochastic inflow to reservoirs could also advantageously include any other stochastic energy production such as wind. However, this is not presently implemented.

The dynamic programming minimises the total expected costs over one year in the countries simulated.

The calculation is in two parts. The first part calculates the total cost for each season corresponding to different levels of hydro production in the season (this was described above). The second part combines these costs with stochastic hydro inflows and hydro reservoir volumes in a backwards-stochastic dynamic program to find the solution that provides the minimum of expected costs.

The optimal production levels of hydro corresponding to each season and reservoir level in the aggregated reservoir are thus found. The optimal production levels of all other technology types associated with each level of hydro production are previously known. Furthermore, the expected marginal costs may be found in the dynamic programming. They represent the water values or electricity prices.

In a forward simulation based on assumptions of hydro inflow, the development of reservoir volume season by season, production (hydro and other types) and water values is calculated.

### **Limitations in the Present Implementation**

The limitations of the present implementation of the one storage model are mainly related to the treatment of stochastic elements other than hydro inflow. In particular, it is not considered that wind power may be stochastic. In order to improve on this, two parts of the algorithm need consideration. One is the generation of the stochastics of wind power in a way that is consistent with the stochastics of the hydro inflow. This is mainly a data problem. The other is in the forward simulation where wind power should influence the amount of hydropower to be used during a week. Some consideration and coding will be needed, however, it is believed that this is a relatively minor part.

Apart from this, some cleaning up of the code is necessary, together with documentation relating thereto.

### **Test Runs and Observations**

The model has been preliminarily tested using the Balmorel model for the description of the deterministic parts of the supply, transmission and demand systems. The hydropower availability, in particular the stochastic elements related to this, was estimated using Nordel monthly data for the period 1990 through to 2002 (from [www.nordel.org](http://www.nordel.org)). Basic functionality of the model seems confirmed.

The dominating part in the calculation time for the above implementation of the one reservoir problem is the calculation of production costs for given quantities of hydropower production. In part, this is due to GAMS requiring generation of a new model for each allocation of hydropower production. The dynamic programming, algorithm, is not particularly time-consuming.

It is believed that the relation between the two parts will remain true when the code is enlarged to convene more than one hydro reservoir, so that the calculation of production cost dominates the calculation time.

However, total calculation time will increase dramatically. When the code is enlarged to convene more than one hydro reservoir, both parts of the calculations (to find the production costs for different quantities of hydro production and to combine them in the dynamic programming algorithm), and the number of combinations to analyse will grow exponentially with the number of reservoirs.

There seems to be no way of avoiding this as a worst-case characteristic, i.e., it is a property of the problem, which is not of the applied solution method.

The strategies for mitigating this are legio. Some of them are Monte Carlo simulation, sampling, development of good stopping criteria, application of knowledge of the system (to eliminate irrelevant calculations), advanced use of computer technique, etc.

It has not at this moment been decided which strategy to use. However, it seems likely that dynamic programming will be attempted, probably in combination with some of the strategies mentioned.

### **Integration of the Long-Term Model and the Joint Market Model**

There is a close relationship between the long-term model and the joint market model, and their mutual dependencies must be established in calculation routines.

The joint market model provides production costs based on a calculation on a detailed hourly model. The daily or weekly production costs are necessary input to the long-term model, as explained above. On the other hand, calculations over a short period of time (e.g., a week), as in the joint market model, are only possible if boundary conditions for beginning and end of the period of time are provided. This applies, in particular, to the hydropower with storage.

Such boundary conditions are supplied by the long-term model in the form of water values for the hydro production system or in the form of weekly hydro production quantities.

The calculation routines for this interplay between the two models will be established in the next phases of the project.

## **4.5 Joint Market Model**

### **Functionality**

The Joint Market model simulates a perfect market place with four types of products: day-ahead market power, district and process heat, regulating power and ancillary services. The actors on the market place maximise their profit through trade on the day-ahead market, the intra-day market and the ancillary services market. Due to the perfect market assumption, this is equivalent to maximising the sum of consumer and producer surplus. For all operational hours in a bidding period on the day-ahead market, the Joint Market model optimises the sum of the consumers'

and producers' surplus on the heat markets, the day-ahead market and the intra-day market. The optimisation is done subject to different constraints such as transmission constraints in the electricity system and capacity constraints of storage and generating technologies. The Joint Market model is a stochastic linear programming model where the optimisation is done subject to a stochastic regulation need on the intra-day market. The first version of the Joint Market model only considers the contribution of the wind power production to the stochastic regulation need, but later versions can include other stochastic parameters such as the power demand.

The model output consists of:

- Day-ahead market production plan for the next bidding period, i.e., how much to produce on the different generating units according to the market clearance on the day-ahead market;
- Hourly day-ahead market prices in each region;
- Hourly transmission between each region;
- Regulating power capacities and regulation power prices in each hour in the bidding period;
- Distribution of ancillary services on power plants.

### **Geography**

The geographical resolution chosen for the Joint Market model has direct implications for the data to be collected and the level of detail for analyses using the Joint Market model.

The geographical resolution chosen for the model defines the spatial distribution of power plants, the consumption, storages, etc. The transmission grid representation in the model is constrained by the overall geographical resolution chosen.

The Joint Market model uses the same basic type of geographical units as the Balmorel model, namely: **countries, regions and areas**.

The relations between these geographical entities are such that a region contains areas, and a country contains regions, cf. *Figure 26*. Areas may be further subdivided into urban and rural areas. The endogenous and exogenous variables will be specified and generated relative to the geographical entities.

The regions are introduced to handle electricity *transmission* aspects and correspond to bidding areas as seen on the Nord Pool market. The *distribution* of electricity within a given region is not included in the model<sup>13</sup>, but different regions can exchange power. The ability within regions of (or the requirements to) the electricity grid in terms of supporting the scenarios focused on must be handled via other model tools (WP5 covers these parts of the analyses).

The areas are the smallest geographical entities. The data given at the level of areas include those related to heat demand and heat distribution.

---

<sup>13</sup> At least only as a distribution loss factor and a distribution tariff.

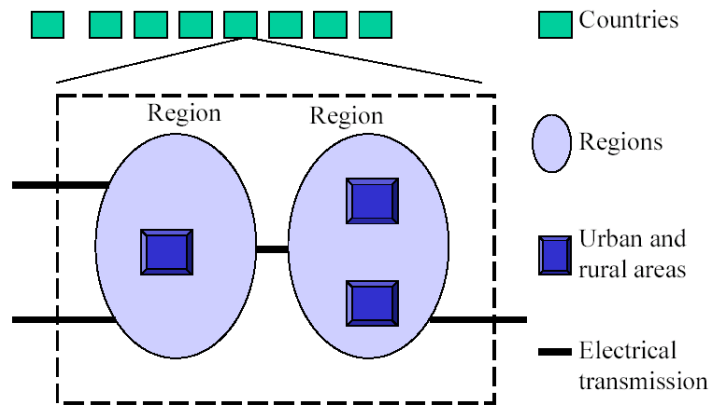

Figure 26: Illustration of the geographical entities and the transmission possibilities [Ravn et al. 2001].

Table 8 shows the imagined geographical resolution of the data.

Table 8: The suggested geographical level of the data

	Area	Region	Country
<b>Data</b>	<ul style="list-style-type: none"> <li>- Data related to heat demand</li> <li>- Data related to heat distribution</li> <li>- Storage and generation technology data</li> <li>- Some fuel prices and fuel potentials</li> </ul>	<ul style="list-style-type: none"> <li>- Data related to electricity demand</li> <li>- Data related to electricity transmission and distribution</li> <li>- Transmission technology data</li> <li>- Water inflow, wind speeds, solar radiation</li> </ul>	<ul style="list-style-type: none"> <li>- Political data</li> <li>- Some fuel prices</li> </ul>

**Countries** covered in the Joint Market model are:

- Denmark
- Finland
- Germany
- Norway
- Sweden

The data given at country level describe overall economic aspects.

At Nord Pool bottlenecks in the transmission grid can be handled either by the formation of price areas or via buy-back mechanisms (see Section ??). Furthermore, the geographical coverage and number of price areas at Nord Pool changes from time to time. The Joint Market model uses regions, which correspond to fixed price areas, in order to treat bottlenecks in the transmission grid.

Sweden, which uses the buy-back mechanism, has been divided into three regions corresponding approximately to Svenska Kraftnäts Snit 2 (dividing South Sweden from middle Sweden) and Snit 4 (dividing middle Sweden from North Sweden). Denmark is divided into two regions corresponding to West Denmark (the Eltra region) and East Denmark (the Elkraft System region). Finland is divided into one region and Norway is divided into three regions. Finally, Germany is divided into three regions.



The definition of **areas** in each region within the Joint Market model is a complicated and still not completed task depending on the availability of heat demand data, the differences between CHP technologies within regions, the differences in heat demand profiles within a region and calculation time considerations.

The exchange of power with regions that are not part of the model (third-party countries) can be represented with price-quantity curves. Through these curves, the amount of exchangeable power dependent on the power price is modelled as sketched in Figure 27.

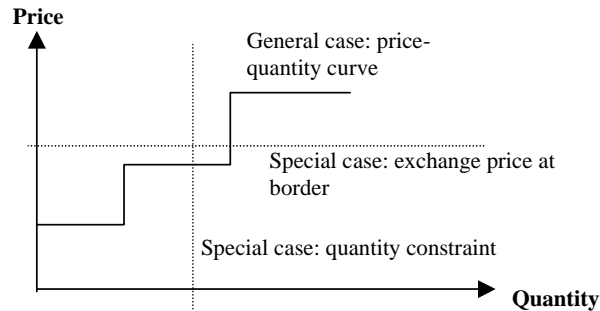

Figure 27: Modelling of exchange with third-party countries using price-quantity curves.

### Time

The finest time resolution in the Joint Market model is one hour. This is in line with the functioning of the present day-ahead market(s).

The regulating power markets operated by Nordic TSO's operate today at a time resolution lower than the hour. The difference between the regulating needs within one hour, e.g., from one quarter to the next, and the regulating needs from one hour to the next must be investigated, so that we know how much we underestimate the regulating power needs when operating at an hour-to-hour level. This issue will be investigated in the Wilmar project.

### Decision Structure

In any model, it is important to understand the decision/stage structure of the problem, i.e., when must decisions be taken, and when does new information arrive that enables new and improved decisions to be taken?

At Nord Pool, bids for the Elspot market must be each day delivered at noon thereby covering the production hours of the next day, i.e., a 24 hour day-ahead market bidding period with a time lag of 12 hours between bid submission and start of the day-ahead market bidding period. Approximately two hours following bid submission, Nord Pool has cleared the Elspot market and returned the amounts sold to and bought from each actor for each hour in the day-ahead market bidding period (see Figure 28).

Operated by the TSO's, a regulating power market runs in parallel with the day-ahead market where bids for up or down regulation to be activated in the actual operation hour must be submitted one hour before the actual hour. The TSO can activate the up or down-regulation bids with a 15 minutes notice, i.e., the time resolution in the regulating power market is below one hour. The bids submitted to the

regulating power market must take the obligations from the day-ahead market into account, i.e., the amounts sold/bought on the day-ahead market influences what can be offered on the regulating power market.

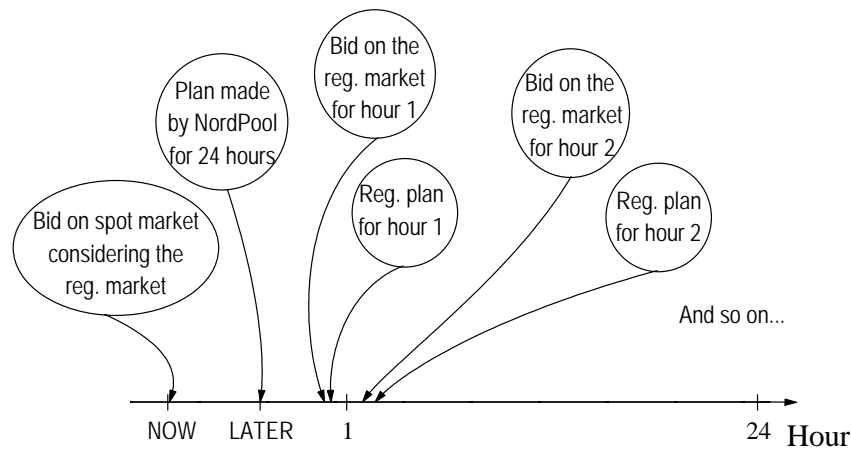

*Figure 28: Illustration of the time structure of the bidding procedures on the Elspot market at Nord Pool and the regulating power markets in the Nordic countries [Nielsen 2003].*

New information arrives on a continuous basis and consists of updated information about the operational status of production and storage units, the operational status of the transmission and distribution grid, updated demand for heating, electricity demand and wind power production forecasts and updated information about day-ahead market and regulating power market prices. Most actors only have access to a limited subset of this information, e.g., an actor only knows the detailed operational status of units owned by him.

Furthermore, because of time-overlapping restrictions, such as storages (heat, electricity), water reservoirs and start/stop times and costs, the operation strategy of a unit needs to be simultaneously decided upon for several production hours.

All in all, a producer with flexible production units making bids to the day-ahead market faces a quite difficult decision problem, because of time-overlapping restrictions on the production output and because the expected profit from participating in the regulating power market in the production hours in the day-ahead market bidding period also need to be taken into account. This decision problem can be formulated mathematically as a multi-stage, stochastic optimisation problem. Multi-stage because bids to the regulating market are made each hour and the day-ahead market bidding period covers 24 hours, and stochastic because the regulating need in a given operation hour is stochastic depending among other things on the accuracy of wind power production forecasts.

Discrete approximations of the distributions of the stochastic parameters are standard in stochastic dynamic programming techniques and will also be employed in the Joint Market model. However, such discrete, stochastic optimisation models quickly become intractable, since the total number of scenarios has a double exponential dependency in the sense that a model with  $k+1$  stages,  $m$  stochastic parameters, and  $n$  scenarios for each parameter (at each stage) leads to a model with a total

of  $s = n^{m^k}$  scenarios. It has, therefore, been necessary to simplify the decision structure of the day-ahead market bids in the Joint Market model.

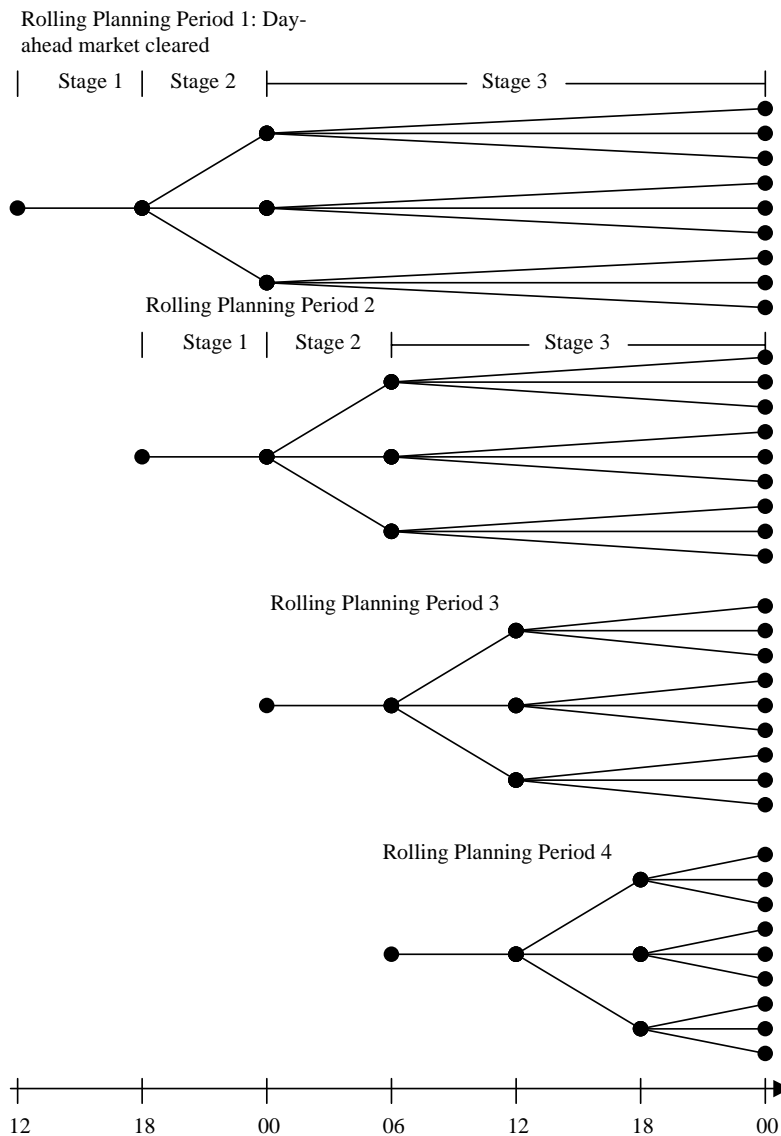

Figure 29: Illustration of the rolling planning and the decision structure in each planning period within a day.

The first version of the Joint Market model is a three-stage model. The model steps forward in time using rolling planning with a 6-hour step. The decision structure in the Joint Market model is illustrated in Figure 29, which shows the scenario tree for four planning periods covering one day. For each rolling planning period, a three-stage, stochastic optimisation problem is solved having a deterministic first stage covering 6 hours, a stochastic second stage with three scenarios covering 6 hours, and a stochastic third stage with 9 scenarios covering a variable number of hours according to the rolling planning period in question. In rolling planning period 1, the production and consumption volumes on the day-ahead market are determined. During the subsequent rolling planning periods, the production and consumption variables on the day-ahead market are fixed on the values found in rolling planning period 1, so that the obligations on the day-ahead market is taken into account when the optimisation of the intra-day trading takes place.

The optimisation done in planning period 1 determines the production, consumption and prices on the intra-day market in hour 12 to 17. The optimisation done in planning period 2 determines the same for the hours 18-23, planning period 3 determines the same for the hours 00 to 5 and finally, planning period 4 for the hours 6 to 11.

By stepping through the planning periods, the production, consumption, exchange and prices on the day-ahead, intra-day and ancillary services market are in this way determined for a given period of time.

A scenario consists of a vector of wind power production forecasts for each region in the number of hours corresponding to the number of hours of the stage in question.

The functioning of the model with the implemented decision structure can be interpreted as one operator with full knowledge of the operational status of all units in the system trying to maximise the consumer and producer surplus in the market. When making bids to the day-ahead market (rolling planning period 1), the operator takes into account the intra-day market knowing that the production decisions related to the intra-day market can be changed twice during the day-ahead market period, namely 6 hours and 12 hours after submitting the bids to the day-ahead market. Furthermore, the wind power production in the first 6 hours is with certainty known, but subsequent hours have uncertain wind power production. After having received information about day-ahead market production and consumption volumes, the operator re-optimises the production decision on the intra-day market every 6 hours having the traded volumes on the day-ahead market as restrictions in the optimisation.

### **Bid Strategy of Consumers and Producers**

The trading rules on the day-ahead market are relatively simplified to those existing on the Nord Pool in that only so-called hourly bids are handled in the model (see Section 2).

A power plant or group of power plants will for each hour in a given day-ahead market bidding period make a bid with the bid price equal to the short-term marginal production costs of the power plant or group of power plants in question. The short-term marginal production costs also include a simplified representation of start/stop costs meaning that the production costs also depend on the status of the power plant in the previous hours.

The amount offered in the bid will be the maximum capacity available in the production hour when different technical restrictions are taken into account minus the capacity that it is optimal to reserve for making up-regulation bids at the intra-day market minus for some units what it is optimal to reserve to providing ancillary services. The technical restrictions that are taken into account are minimum and maximum capacities, ramp rates<sup>14</sup>, minimum operation times, minimum shutdown times, and for backpressure and extraction CHP plants, the connections between heat and power production in the form of  $c_b$  and  $c_v$  lines. Minimum capacities, minimum operation times and minimum shutdown times are modelled with a simplified approach so that the Joint Market model can be kept as a linear programming model.

---

<sup>14</sup> A restriction on how fast the power production can change from one hour to the next.

The supply curve on the day-ahead market in a given hour is made by aggregating all production units after increasing price, thereby forming a piece-wise linear supply curve.

If we knew the willingness to pay and the electricity demand of all consumers for each hour during a year, price flexible demand curves could be constructed in a similar fashion as the supply curves by aggregating the buy bids after decreasing willingness to pay. As this information is not available, a price flexible demand curve is constructed by combining a nominal electricity consumption with a piece-wise linear electricity function with a given number of steps.

In a situation without transmission restrictions in the system, the cross between the supply curve on the day-ahead market constructed in the above-mentioned fashion and the demand curve on the day-ahead market determines the electricity price for the hour in question and all sale and buy bids on the left of the market cross are accepted and turned into production and consumption obligations in that hour.

After determination of production and consumption volumes on the day-ahead market, the remaining available capacity will be offered to the intra-day market, again taking the above-mentioned technical restrictions into account.

## 5 Concluding remarks

This report treats two overall fundamental issues of importance for the Wilmar-project: 1) The functioning of the power markets in the Nordic countries and Germany and 2) how a power market can be modelled within the Wilmar-modelling concept.

With regard to the description of the power markets, the different reserve power types and physical energy markets that are present in Germany and the Nordic countries are summarised in the table below. As shown quite a number of different markets exist making the analysis of power markets quite complicated. Some markets, e.g., the Elspot market at Nord Pool are common for all Nordic countries (except Iceland), while the functioning of others are specific for each country or TSO area, e.g., the way adequate amounts of primary reserves are secured by the TSO. The terminology used for different types of reserve power also differs between Germany and the Nordic countries. It is not possible to include all power markets in the Planning tool due to calculation time considerations, so a subset of the existing markets has been carefully selected to be included in the Planning tool as presented below.

*Table 9 Overview of the reserve power types and markets in Germany and the Nordic countries. The ancillary services are described with normal text style and the markets connected to the provision of ancillary services with the text in italics. The energy markets are described with normal text style.*

<b>Reserves, by Activation</b>	<b>Germany</b>	<b>Nordic Countries</b>
Frequency	Primary <i>Public auction, 6 months before covering 6 months ahead</i>	Primary Momentary disturbance <i>Capacity reserved using agreements between TSO's and certain producers, different arrangements for different countries</i>
Automatic load flow	Secondary <i>Public auction, 6 months before covering 6 months ahead</i>	
Manual, 15 min	Minute reserves (also called Tertiary)  Day-ahead market: Capacity price (if selected) + Energy price (if activated)	Fast reserves (also called: Regulating power, Secondary) <i>Regulating power market: TSO's buy regulation, Capacity reserved for making bids at this market months ahead (reserve capacity market)</i>
Manual, hours	Existing as OTC-market; responsibility with Gencos, not with TSO's	Tertiary
<b>Energy markets, by (approximate) time to delivery:</b>		
Day-ahead	EEX Day-ahead, often called Spot market	Nord Pool Elspot, often called Spot market
Balancing market	Almost non-existing (only OTC)	Nord Pool Elbas (only S + F), Hour-ahead market

The second part of the report gives an overview over power market models used in the literature, and presents two power market models that will be implemented in the Planning tool developed in the Wilmar project. The Long-Term model handles the distribution of hydropower production and the distribution of CO<sub>2</sub> emissions during a year taking the stochasticity of water inflow into account. Day-ahead markets for electricity, district heating and industrial process heat are represented in the Long-term model with a more coarse time resolution than the hourly time steps used in the real markets. The Joint Market model has an hourly time resolution and includes the following markets:

- Day-ahead market for electricity and heat, price flexible demand.
- Intra-day (regulating power) market with price inflexible demand.
- Ancillary services market i.e. market for automatic activated reserves (frequency and load flow) with price inflexible demand.

It takes the stochasticity of wind power production into account when optimising the trade on these markets.

The next steps to be taken on the project are to implement the first versions of the Long-Term model and the Joint Market model in the modelling language GAMS, which are expected to be finished at the beginning of 2004. The corresponding data collection has also shown good progress and a nearly complete data set will be available within the same timeframe. Thus, the testing phase of the Planning tool is expected to start in early Spring with the goal of presenting the first results from calculations with the Planning tool before Summer 2004.

## 6 References

- Andersson, B., Bergman, L. (1995): Market structure and the price of electricity: An ex ante analysis of the deregulated Swedish electricity market. In: *The Energy Journal* 16, pp. 97 – 110.
- Baldick, R., Hogan W. (2001): Capacity Constrained Supply Function Equilibrium Models of Electricity Markets: Stability, Non - decreasing Constraints, and Function Space Iterations. Working papers series of the Program on Workable Energy Regulation (POWER) PWP - 089. Berkeley CA.
- Barlow, M. T. (2002): A diffusion model of electricity prices. In: *Mathematical Finance* 12, pp. 287 - 298.
- Bolle, F. (1992): Supply Function Equilibria and the Danger of Tacit Collusion: The Case of Spot Markets for Electricity. In: *Energy Economics* 14, pp. 94 - 102
- Bolle, F. (2001): Competition with Supply and Demand Functions. In: *Energy Economics* 23, pp. 253 - 277.
- Borenstein, S., Bushnell, J., Knittel C. R. (1999): Market Power in Electricity Markets: Beyond Concentration Measures. In: *The Energy Journal* 20, pp. 65 - 88.
- Crampes, C., Creti, A. (2002): Capacity Competition in Electricity Markets. Working paper IDEI, University of Toulouse.
- Cuaresma, J. C., Hlouskova, J., Kossmeier, S., Obersteiner, M. (2003): Forecasting Electricity Spot Prices Using Linear Univariate Time Series Models. In: *Applied Energy* 76 (forthcoming).
- Dahl, C., Erdogan, M. (1994): Econometric Energy Demand and Supply Elasticities: Truth or Fiction. In: *Proceedings of the 17th Annual International Energy Conference*. Cleveland.
- Dennerlein, R. (1990): *Energieverbrauch privater Haushalte*. Augsburg.
- EEX, EEX Spotmarktkonzept. 2003a, European Energy Exchange (EEX): Leipzig.
- EEX, EEX Terminmarktkonzept. 2003b, European Energy Exchange (EEX): Leipzig.
- EEX, Clearingbedingungen für den Auktionenhandel am Spotmarkt. 2002a, European Energy Exchange (EEX): Leipzig.
- EEX, Clearingbedingungen für den Fortlaufenden Handel am Spotmarkt. 2002b, European Energy Exchange (EEX): Leipzig.
- Ellersdorfer, I. (2003): *Modellierung von Wettbewerb in der Stromwirtschaft*. Ph. D. under preparation. Stuttgart, Oldenburg.
- Ellersdorfer, I., Specht, H., Fahl, U., Voß, A. (2001): Wettbewerb und Energieversorgungsstrukturen der Zukunft. Forschungsbericht des IER, Universität Stuttgart Band 81.
- Ellersdorfer, I., Blesl, M., Traber, T., Fahl, U., Kessler, A. (2003): Marktposition deutscher EVU im liberalisierten europäischen Elektrizitätsmarkt. – Analysen mit einem spieltheoretischen Modellansatz. In: *Energiewirtschaftliche Tagesfragen* 53 (forthcoming).
- ELTRA (2003): [www.ELTRA.dk](http://www.ELTRA.dk).
- Erdmann, G., Federico, T. (2001). Time Series Analysis and Forecasting of German Peakload Prices. The Approach of [www.prognoseforum.de](http://www.prognoseforum.de). Presentation at 2. Internationale Energiewirtschafts - Tagung, 13. – 15. Februar 2001. TU Wien.
- European Commission (1997): *Energy for the Future: Renewable Sources of Energy* (White Paper).



- European Commission (2000): Proposal for a Directive of the European Parliament and of the Council on the Promotion of Electricity from Renewable Energy Sources in the Internal Electricity Market.
- Gilbert, R., Neuhoff, C., Newbery, D. (2002): Mediating Market Power in Networks. In: Proceedings of the 25<sup>th</sup> Annual IAEE International Conference, Aberdeen June 26 – 29, 2002.
- Green, R.J., Newbery, D.M. (1992): Competition in the British electricity spot market. In: *Journal of Political Economy* 100, pp. 929 - 953.
- Harvey, S. M., Hogan, W. W. (2000): Nodal and Zonal Congestion Management and the Exercise of Market Power. [http://ksghome.harvard.edu/~.whogan.cbg.Ksg/zonal\\_jan10.pdf](http://ksghome.harvard.edu/~.whogan.cbg.Ksg/zonal_jan10.pdf), accessed August 6, 2003
- Hobbs, B. F. (2001): Linear Complementarity Models of Nash–Cournot Competition in Bilateral and POOLCO Power Markets. In: *IEEE Transactions on Power Systems* 16, pp. 194 – 202.
- Hobbs, B. F. Metzler, C., Pang J.S. (2000): Calculating Equilibria in Imperfectly Competitive Power Markets: An MPEC Approach. In: *IEEE Transactions on Power Systems* 15, pp. 638 - 645.
- Hull, J. C. (2000): *Options Futures and Other Derivatives*. 4<sup>th</sup> ed. Upper Saddle River NJ.
- Jebjerg, L. Riechmann, C. (2001): Prognose von Anbieterstrategien im Stromgroßhandel – Konzepte und internationale Erfahrungen. In: Proceedings der 2. Internationalen Energiewirtschafts - Tagung 21. - 23. Februar 2001. TU Wien.
- Johnson, B., Barz, G. (1999). Selecting Stochastic Processes for Modelling Electricity Prices. In: *Risk Books (ed.): Modelling and the Management of Uncertainty*, Haymarket House, London, pp. 3 - 22.
- Klemperer, P. D., Meyer M. A. (1989): Supply Function Equilibria in Oligopoly under Uncertainty. In: *Econometrica* 57, pp. 1243 – 1277.
- Kramer, N.: Modellierung von Preisbildungsmechanismen im Strommarkt. Ph. D. Freiberg.
- Kreuzberg, M. (1999). Spotpreise und Handelsflüsse auf dem europäischen Strommarkt - Analyse und Simulation. In: *Zeitschrift für Energiewirtschaft* 23, pp. 43 - 63.
- Kurihara, I. et al, (2002): Computer Simulation of Electricity Market - Development of Fundamental Electricity Model using Multi Agent System, CRIEPI Report No T01036 , short summary in: CRIEPI, annual research report. <http://criepi.denken.or.jp/eng/PR/Nenpo/2002E/02seika19.pdf>, accessed July 31, 2003.
- Lucia, J. J., Schwartz, E. S. (2002): Electricity prices and power derivatives: Evidence from the Nordic power market. In: *Review of Derivative Research* 5, pp. 5 - 50.
- Metzler, C., Hobbs, B.F., Pang J.S. (2003): Nash - Cournot Equilibria in Power Markets on a Linearized DC Network with Arbitrage: Formulations and Properties. In: *Networks & Spatial Economics* 3, pp. 123 - 150.
- Morthorst, P.E. (2003): Wind Power and the Conditions at a Liberalised Power Market, *Wind Energy*, vol.6, no.3.
- Müsgen, F., Kreuzberg, M. (2001) Einfluss der Speicherkraftwerke in der Alpenregion auf die Strompreise in Deutschland – Eine modellgestützte Analyse. In: Proceedings of the 2. Internationale Energiewirtschaftstagung. TU Wien.
- Newbery, D. (1998): Competition, Contracts and Entry in the Electricity Spot Market. In: *Rand Journal of Economics* 29, pp. 726 – 749.
- NordEls årsberetning 2002: Fælles balancehåndtering i Norden.
- NordEls årsberetning 2000: Håndtering av nettbegrensninger i elkraftsystemet.
- Pilipovic, D. (1998): *Energy Risk*. New York et al.

- Ramanathan, R., Engle, R., Granger, C.W.J., Vahid-Araghi, F., Brace, C. (1997): Short-run forecasts of electricity loads and peaks. In: *International Journal of Forecasting*, 13, pp. 161 - 174.
- Ravn, H. et al. (2001), Balmorel: A Model for Analyses of the Electricity and CHP Markets in the Baltic Sea Region, [www.balmorel.dk](http://www.balmorel.dk).
- Smeers, Y., (1997): Computable Equilibrium Models and the Restructuring of the European Electricity and Gas Markets. In: *The Energy Journal* 18, pp. 1 – 31.
- Swider, D. J. und Weber, C., Regelenergiemarkt in Deutschland – Ausgestaltung und Preisanalyse. *CD-Rom zur 3. Internationalen Energiewirtschaftstagung an der TU Wien, Österreich, 12.-14.02.2003*, [online] <http://elib.uni-stuttgart.de/opus/volltexte/2003/1371>, 2003a.
- Swider, D. J. und Weber, C., Ausgestaltung des deutschen Regelenergiemarktes. *Energiewirtschaftliche Tagesfragen* 53(7): 448-453, 2003b.
- von der Fehr, N.-H. M., Harbord, D. C. (1997): Capacity Investment and Competition in Decentralized Electricity Markets. Department of Economics, University of Oslo Memorandum No. 27/97. Oslo.
- Weber, C. (2001): Preiswettbewerb im Strommarkt – zur Bedeutung von Marktmacht, Produktdifferenzierung und Marktsegmentierung. In: *Proceedings of 2. Internationale Energiewirtschaftstagung February 21 – 23, 2001, Wien*.
- Weber, C. (2003a): Combining bottom - up and finance modelling for electricity markets. In: *Leopold - Wildburger, Rendl, U. F., Wäscher, G.: Operations Research Proceedings 2002 Selected Papers of the International Conference on Operations Research (SOR 2002), Klagenfurt, September 2 - 5, 2002*. Springer: Berlin u. a. 2003, pp. 272 - 277.
- Weber, C. (2003b): Models for decision making under uncertainty in the electricity industry. Habilitation under preparation.

Title and authors

**Power System Models - A Description of Power Markets and  
Outline of Market Modelling in Wilmar**

Peter Meibom, Risø National Laboratory  
Poul Erik Morthorst, Risø National Laboratory  
Lars Henrik Nielsen, Risø National Laboratory  
Christoph Weber, IER, University of Stuttgart  
Kai Sander, IER, University of Stuttgart  
Derk Swider, IER, University of Stuttgart  
Hans Ravn, Technical University of Denmark

---

ISBN	ISSN
ISBN 87-550-3288-5 (Internet)	0106-2840

---

Department or group	Date
	19.12.2003

---

Groups own reg. number(s)	Project/contract No(s)
	ENK5-CT-2002-00663

---

Sponsorship

---

Pages	Tables	Illustrations	References
65	9	29	50

---

Abstract

This report is Deliverable 3.2 of the Wilmar project. The report describes the power markets in the Nordic countries and Germany, together with the market models to be implemented in the Wilmar Planning modelling tool developed in the project.

Descriptors INIS/EDB

DENMARK; ELECTRIC POWER; FEDERAL REPUBLIC OF GERMANY;  
FINLAND; MANAGEMENT; MARKET; MATHEMATICAL MODELS;  
NORWAY; POWER GENERATION; POWER POOLING; POWER  
SYSTEMS; RENEWABLE ENERGY SOURCES; SWEDEN; WIND POWER