

## Distortional buckling modes of semi-discretized thin-walled columns

**Andreassen, Michael Joachim; Jönsson, Jeppe**

*Published in:*  
Thin-Walled Structures

*Link to article, DOI:*  
[10.1016/j.tws.2011.11.002](https://doi.org/10.1016/j.tws.2011.11.002)

*Publication date:*  
2012

*Document Version*  
Early version, also known as pre-print

[Link back to DTU Orbit](#)

*Citation (APA):*  
Andreassen, M. J., & Jönsson, J. (2012). Distortional buckling modes of semi-discretized thin-walled columns. *Thin-Walled Structures*, 51, 53-63. DOI: 10.1016/j.tws.2011.11.002

## DTU Library

Technical Information Center of Denmark

---

### General rights

Copyright and moral rights for the publications made accessible in the public portal are retained by the authors and/or other copyright owners and it is a condition of accessing publications that users recognise and abide by the legal requirements associated with these rights.

- Users may download and print one copy of any publication from the public portal for the purpose of private study or research.
- You may not further distribute the material or use it for any profit-making activity or commercial gain
- You may freely distribute the URL identifying the publication in the public portal

If you believe that this document breaches copyright please contact us providing details, and we will remove access to the work immediately and investigate your claim.

# Distortional buckling modes of semi-discretized thin-walled columns

Michael Joachim Andreassen, Jeppe Jönsson

*Technical University of Denmark, Department of Civil Engineering, Brovej Building 118,  
DK-2800 Kgs. Lyngby*

---

## Abstract

This paper presents distorting buckling solutions for semi-discretized thin-walled columns using the coupled differential equations of a Generalized Beam Theory (GBT). In two related papers recently published by the authors a novel semi-discretization approach to GBT has been presented. The cross section is discretized and analytical solutions are sought for the variation along the beam. With this new approach the general GBT equations for identification of a full set of deformation modes corresponding to both homogeneous and non-homogeneous equations are formulated and solved. Thereby giving the (complex) deformation modes of GBT which decouple the state space equations corresponding to the reduced order differential equations.

In this paper the developed semi-discretization approach to Generalized Beam Theory (GBT) is extended to include the geometrical stiffness terms, which are needed for column buckling analysis and identification of buckling modes. The extension is based on an initial stress approach by addition of the related potential energy terms. The potential energy of a single deformation mode is formulated based on a discretization of the cross section. Through variations in the potential energy and the introduction of the constraints related to beam theory this leads to a modified set of coupled homogeneous differential equations of GBT with initial stress for identification of distortional displacement modes. In this paper we seek instability solutions using these GBT initial stress equations for simply supported columns with constrained transverse displacements at the end sections and a constant axial initial stress. Based on the known boundary conditions the reduced order differential equations are solved by using the trigonometric solution functions and solving the related eigenvalue problem. This gives the buckling mode shapes and the associated eigenvalues corresponding to the bifurcation load factors. Thus the buckling modes are found directly by the analytical solution of the coupled GBT-equations without modal decomposition. Illustrative examples showing global column buckling, distortional buckling and local buckling are given and it is shown how the novel approach may be used to develop signature curves and elastic buckling curves. In order to assess the accuracy of the method some of the results are compared to results found using the commercial FE program Abaqus as well as the conventional GBT and FSM methods using the software packages GBTUL and CUFSM.

*Key words:* Thin-walled beams, Beam theory, Stability, Distortion, Warping, Distortional beam theory, Generalized beam theory, Semi-discretization, Bifurcation, Buckling, Columns.

---

## 1. Introduction

An assessment of the structural performance of thin-walled beams includes linear static analysis and linear buckling analysis of the behavior. Linear buckling analysis is used to achieve an estimate of the load level at which certain types of structures exhibit a loss of stability through large non-linear deformations. Typically for these structures membrane strain energy is converted

into flexural strain energy with very little change in externally applied load. In slender columns and thin plates or shells, the membrane stiffness is much greater than the bending stiffness, and large strain energy can be stored with very small membrane deformations. Therefore the deformations of the fundamental state are neglected and the displacements are measured from the initial perfect configuration. As the membrane stiffness is much greater than bending stiffness, comparatively large bending deformations are needed to absorb the membrane strain energy released when buckling occurs. In most buckling cases of practical interest this

---

*Email addresses:* [mican@byg.dtu.dk](mailto:mican@byg.dtu.dk) (Michael Joachim Andreassen), [jej@byg.dtu.dk](mailto:jej@byg.dtu.dk) (Jeppe Jönsson)

*Preprint submitted to Thin-Walled Structures*

*December 14, 2011*

means that the geometric stiffness term (for compressional loading) gives a negative contribution to the total stiffness. In other words, instability may be considered as the load level at which added elastic stiffness terms are fully neutralized by a change in added negative geometric stiffness terms in the potential energy. In this paper we therefore include initial stress contributions to the potential energy which allow us to perform linear distortional buckling analysis of semi-discretized thin-walled members.

The classic stability analysis of thin-walled columns is based on a combination of the “in-plane rigid” cross-section displacement modes (Vlasov modes,[1]) corresponding to: Uniform axial extension, major axis bending, minor axis bending and torsion with related warping. An important feature missing here is the deformation of the cross section, which undergoes in-plane deformations by local and distortional modes. Concerning analysis of thin-walled members including distortion of the cross section there are a number of methods available among which are: (i) The use of shell finite elements in the finite element method (FEM), [2], [3], perhaps with utilization of recursive substructuring, [4], (ii) the finite strip method (FSM), [5], [6], [7], [8], [9], and (iii) the use of approximate GBT-finite beam elements. In this context the first application of the first generation of GBT to buckling analysis was published in 1970 by Schardt [10]. Among others also Davies [11], Lepistö [12], Simão [13] and Camotim [14] has investigated the area. This paper deals with a novel method based on solution of the differential initial stress equations of GBT obtained through semi-discretization and application of beam constraints. In the two related papers by the authors [15] and [16] a novel finite element based semi-discretization approach to generalized beam theory (GBT) is presented. In contrast to the traditional GBT formulations which do not solve the differential equations but establish a weak solution through introduction of mode shapes (based on an orthogonal shear stiffness assumption) and use approximate modal amplitude functions, the novel approach in [15] and [16] finds the exact modes shapes and amplitude solutions of the reduced order GBT equations related to the discretized cross section. In the same context the novel approach in [15] and [16] adhere to the definition of the warping function given by Kollbrunner & Hajdin, [17], which adds the integral of the shear flow strains, see also [18] and [19]. For a more elaborate description see the companion paper, [15].

In this paper the developed semi-discretization formulation is extended by including the initial stress terms. The potential energy of a single deformation

mode is formulated based on the discretization of the cross section. Through variations in the potential energy and the introduction of the constraints related to beam theory this leads to a modified set of coupled homogeneous differential equations of GBT with initial stress for identification of distortional buckling modes. In this paper we seek “simple” instability solutions using these GBT initial stress equations for the classical simply supported columns with constrained transverse displacements at the end sections and a constant axial initial stress. Based on the known boundary conditions the reduced order differential equations are solved by introducing the relevant trigonometric solution function and solving the related eigenvalue problem. This directly gives us the cross-section buckling mode shape and the eigenvalue corresponding to the bifurcation load factor. This is done as in conventional FSM without the use of modal decomposition as conventionally performed in GBT.

Let us shortly make an outline of this paper. We will start out by introducing the basic assumptions and kinematic relations in Section 2. The displacements of a single mode are separated into the products of cross-section displacement functions and the axial variation functions. Furthermore the expressions for the strains are derived and the element interpolation functions as well as the nodal displacement components of a straight cross-section element are described. Based on simple constitutive relations the potential elastic energy as well as the potential energy contribution of the factored initial stress is formulated in Section 3. Furthermore the global geometrical stiffness matrix is formulated and the load parameter  $\lambda$  is introduced. Section 4 is split into two main steps leading to the final distortional differential equations of double size to which we want to find solutions. In step I we perform variations in the potential energy whereby the pure axial extension mode and its homogeneous solution is identified and eliminated. In Step II the constraint equations relating to the assumption of a constant wall width are introduced, and the rigid translations and the rigid rotational cross-section displacement eigenmodes are identified and orthogonalized. As in classic beam theory the elimination or separate formulation of the flexural and torsional buckling equations (including initial stress terms) are not possible since they now couple with each other and with the remaining distortional equations. This results in global modes which always include distortion of the cross section to a certain degree. The order of the differential equations is reduced by doubling the number of equations through the introduction of a state vector with components of different differentiation levels. From

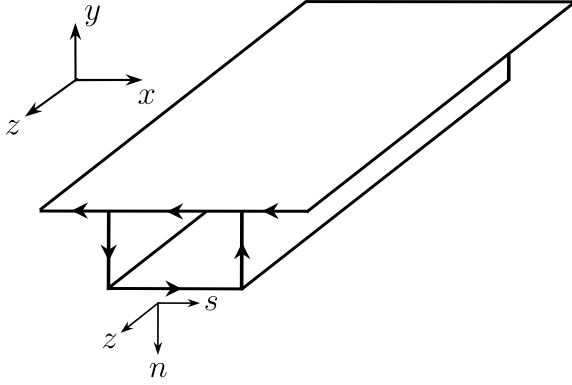

Figure 1: Global and local Cartesian reference frames.

the final differential equations the eigenvalue problem is formulated. In Section 5 trigonometric solutions of the eigenvalue problem are considered. Finally Section 6 is devoted to illustrative examples including development of classic buckling curves and comparison of results with finite element results found using Abaqus, [20], as well as with FSM and conventional GBT results found using the freely available software packages CUF5M and GBTUL, see [21] and [22].

## 2. Basic assumptions and kinematic relations

The prismatic beam is described in a global Cartesian  $(x, y, z)$  coordinate system as shown in Figure 1. From the figure it is seen that a local coordinate system  $(z, n, s)$  corresponding to the normal and tangential directions is introduced. In the local coordinate system the displacements  $u_n$ ,  $u_s$  and  $u_z$  are introduced as

$$u_n(s, z) = w_n(s) \psi(z) \quad (1)$$

$$u_s(n, s, z) = (w_s(s) - n w_{n,s}(s)) \psi(z) \quad (2)$$

$$u_z(n, s, z) = -(\Omega(s) + n w_n(s)) \psi'(z) \quad (3)$$

For the local transverse displacements  $u_n(s, z)$  and  $u_s(n, s, z)$ , the components  $w_s(s)$  and  $w_n(s)$  are the local displacements of the centerline and  $\psi(z)$  is the function which describes the axial variation of the in-plane distortional displacements. For the axial displacements  $u_z(n, s, z)$  generated by the out-of-plane distortional cross-sectional displacements, the axial (warping) displacement mode  $\Omega(s)$  has been included with a variation corresponding to the negative axial derivative of the axial variation factor,  $-\psi'$ , and due consideration of local transverse variation through the term  $n w_n$ . The local components are shown in Figure 2.

The corresponding strains referred to as the axial strains, transverse strains and engineering shear strains, respectively, are introduced as

$$\varepsilon_z = -(\Omega + n w_n) \psi'' \quad (4)$$

$$\varepsilon_s = (w_{s,s} - n w_{n,s,s}) \psi \quad (5)$$

$$\gamma_{zs} = (w_s - \Omega_{,s} - 2n w_{n,s}) \psi' \quad (6)$$

In this approach the thin-walled cross section is discretized in straight cross-sectional elements. The thickness of the individual plane cross-section element is denoted by  $t$  and the width of the wall element by  $b_{el}$ . The modal displacements of the individual wall element is interpolated using the following interpolation functions:

$$\Omega \psi' = \mathbf{N}_\Omega \mathbf{v}_\Omega^{el} \psi' \quad (7)$$

$$w_s \psi = \mathbf{N}_s \mathbf{v}_w^{el} \psi \quad (8)$$

$$w_n \psi = \mathbf{N}_n \mathbf{v}_w^{el} \psi \quad (9)$$

in which  $\mathbf{N}_\Omega(s)$  and  $\mathbf{N}_s(s)$  are linear interpolation matrices and  $\mathbf{N}_n(s)$  is a cubic (beam) interpolation matrix. Furthermore we have introduced the axial and transverse nodal displacement components of a straight cross-section element as

$$\mathbf{v}_\Omega^{el} = \begin{bmatrix} v_{\Omega 1}^{el} & v_{\Omega 2}^{el} \end{bmatrix}^T$$

$$\mathbf{v}_w^{el} = \begin{bmatrix} v_{w 1}^{el} & v_{w 2}^{el} & v_{w 3}^{el} & v_{w 4}^{el} & v_{w 5}^{el} & v_{w 6}^{el} \end{bmatrix}^T \quad (10)$$

The nodal components and the direction of the section coordinates  $(n, s)$  are shown in Figure 3. Assembling the local element degrees of freedom, the global displacement vectors for the total cross section are given as

$$\mathbf{v}_\Omega = [v_{\Omega 1} \ v_{\Omega 2} \ v_{\Omega 3} \ \dots]^T$$

$$\mathbf{v}_w = [v_{x1} \ v_{y1} \ \phi_1 \ v_{x2} \ v_{y2} \ \phi_2 \ \dots]^T \quad (11)$$

where the axial displacements and the transverse displacements are separated into two vectors. The number of degrees of freedom  $n_{dof}$  in the cross section is four times the number of nodes,  $n_{dof} = 4n_{no}$ .

## 3. Energy assumptions and initial stress

The internal energy potential introduced in paper [15] and [16] will be briefly presented in this section as well as the new contribution to the potential energy of the initial stress terms, which are adequate for distortional buckling analysis of thin-walled members.

In the classic beam theory simple constitutive relations are used, which means that the material is assumed to be linear elastic with a modulus of elasticity  $E$  and shear modulus  $G$ . In this paper also a plate elasticity

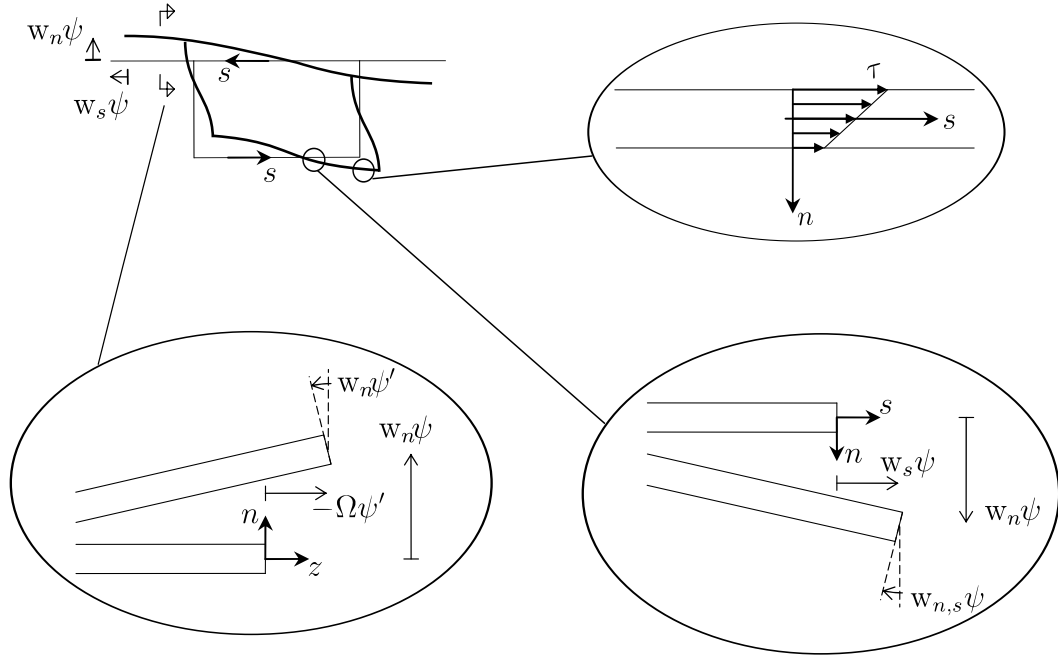

Figure 2: Local components of the displacement field and assumed shear stresses.

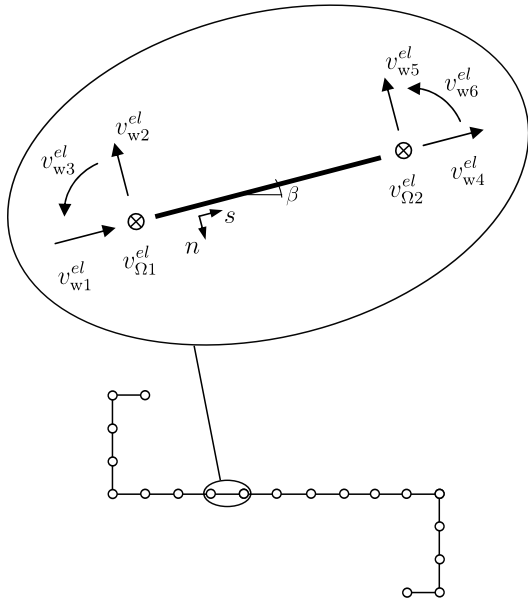

Figure 3: Nodal components of a straight single flat element.

modulus  $E_s = E/(1 - \nu^2)$  in the transverse direction is utilized. The axial stress is determined as  $\sigma_z = E\varepsilon_z$ , the shear stress as  $\tau = G\gamma$  and finally the transverse stress as  $\sigma_s = E_s\varepsilon_s$ . Thus taking the transverse plate bending effect into account but neglecting the coupling of axial strain  $\varepsilon_z$  and transverse strain  $\varepsilon_s$ . With the constitutive relations assumed the basic elastic energy potential becomes

$$\Pi_{int} = \int_V \left( \frac{1}{2} E \varepsilon_z^2 + \frac{1}{2} G \gamma^2 + \frac{1}{2} E_s \varepsilon_s^2 \right) dV \quad (12)$$

Let us next introduce the contribution to the potential energy of a constant uniform initial stress  $\sigma^0$  which is adequate for column buckling analysis. Following conventional methods the initial stress  $\sigma^0$  will be scaled by a factor  $\lambda$ . After having utilized linear equilibrium of the pre-buckling state and neglected contribution corresponding to the squared strain term  $\frac{1}{2} \lambda \sigma^0 u_{z,z}^2 = \frac{1}{2} \lambda \sigma^0 \varepsilon^2$  the potential energy contribution of the factored initial stress is given by

$$\begin{aligned} \Pi_0 &= \int_V \left( \frac{1}{2} \lambda \sigma^0 u_{s,z}^2 + \frac{1}{2} \lambda \sigma^0 u_{n,z}^2 \right) dV \\ &= \int_V \left( \frac{1}{2} \lambda \sigma^0 (u_s')^2 + \frac{1}{2} \lambda \sigma^0 (u_n')^2 \right) dV \end{aligned} \quad (13)$$

Let us introduce a thin-walled cross section assembled by using straight cross-sectional elements. This allows us to integrate the internal energy across the vol-

---

$$\begin{aligned}
\mathbf{k}_{\Omega\Omega}^{\sigma} &= \int_0^{b_e} Et\mathbf{N}_{\Omega}^T\mathbf{N}_{\Omega}ds \\
\mathbf{k}_{ww}^{\sigma} &= \int_0^{b_e} \frac{Et^3}{12}\mathbf{N}_n^T\mathbf{N}_ndz \\
\mathbf{k}^s &= \int_0^{b_e} \left( E_s t \mathbf{N}_{s,s}^T \mathbf{N}_{s,s} + \frac{E_s t^3}{12} \mathbf{N}_{n,s}^T \mathbf{N}_{n,s} \right) dz \\
\mathbf{k}_{ww}^{\tau} &= \int_0^{b_e} \left( Gt \mathbf{N}_s^T \mathbf{N}_s + \frac{Gt^3}{3} \mathbf{N}_{n,s}^T \mathbf{N}_{n,s} \right) dz \\
\mathbf{k}_{\Omega\Omega}^{\tau} &= \int_0^{b_e} Gt \mathbf{N}_{\Omega,s}^T \mathbf{N}_{\Omega,s} dz \\
\mathbf{k}_{w\Omega}^{\tau} &= \left[ \mathbf{k}_{\Omega w}^{\tau} \right]^T = - \int_0^{b_e} Gt \mathbf{N}_s^T \mathbf{N}_{\Omega,s} dz
\end{aligned}$$

---

Table 1: Elastic stiffness contributions of one wall element.

ume of the thin-walled beam. The elastic potential energy of a single mode takes the following form after the introduction of the strains expressed by the separated displacement functions:

$$\begin{aligned}
\Pi_{int} &= \\
\frac{1}{2} \int_0^L & \left[ \sum_{el} \int_0^{b_{el}} \left\{ [Et(\Omega\psi'')^2 + \frac{1}{12}Et^3(w_n\psi'')^2] \right. \right. \\
& + [Gt(w_s\psi')^2 + Gt(\Omega_s\psi')^2 \\
& \left. \left. - 2Gt(w_s\psi')(\Omega_s\psi') + \frac{1}{3}Gt^3(w_{n,s}\psi')^2] \right. \right. \\
& \left. \left. + [E_s t (w_{s,s}\psi)^2 + \frac{1}{12}E_s t^3 (w_{n,s,s}\psi)^2] \right\} dz \right] ds \quad (14)
\end{aligned}$$

The elastic energy terms have been grouped in axial strain energy, shear energy, and transverse strain energy.

The factored initial stress contribution of a single mode to the potential energy takes the following form after introduction of straight cross-sectional wall elements, displacement derivatives and integration through the thickness:

$$\begin{aligned}
\Pi_0 &= \frac{1}{2} \int_0^L \left[ \sum_{el} \int_0^{b_{el}} \lambda\sigma^0 \left\{ t(w_n\psi')^2 + t(w_s\psi')^2 \right. \right. \\
& \left. \left. + \frac{1}{12}t^3(w_{n,s}\psi')^2 \right\} dz \right] ds \quad (15)
\end{aligned}$$

Introducing the displacement interpolation functions into the internal elastic potential energy leads to the definition of several stiffness sub-matrices as given in Table 1. The superscripts  $\sigma$ ,  $\tau$  and  $s$  correspond to components of the axial stiffness, shear stiffness and transverse stiffness, respectively. After transformation of the individual wall elements to global degrees of freedom  $\mathbf{v}_w$  and  $\mathbf{v}_{\Omega}$  and assembly, the cross-section elastic potential

as introduced in [15] takes the form

$$\begin{aligned}
\Pi_{int} &= \frac{1}{2} \int_0^L \left\{ \left[ \psi \mathbf{v}_w^T \quad \psi \mathbf{v}_{\Omega}^T \right]'' \begin{bmatrix} \mathbf{K}_{ww}^{\sigma} & \mathbf{0} \\ \mathbf{0} & \mathbf{K}_{\Omega\Omega}^{\sigma} \end{bmatrix} \begin{bmatrix} \psi \mathbf{v}_w \\ \psi \mathbf{v}_{\Omega} \end{bmatrix}'' \right. \\
& + \left[ \psi \mathbf{v}_w^T \quad \psi \mathbf{v}_{\Omega}^T \right]' \begin{bmatrix} \mathbf{K}_{ww}^{\tau} & \mathbf{K}_{w\Omega}^{\tau} \\ \mathbf{K}_{\Omega w}^{\tau} & \mathbf{K}_{\Omega\Omega}^{\tau} \end{bmatrix} \begin{bmatrix} \psi \mathbf{v}_w \\ \psi \mathbf{v}_{\Omega} \end{bmatrix}' \\
& \left. + \left[ \psi \mathbf{v}_w^T \quad \psi \mathbf{v}_{\Omega}^T \right] \begin{bmatrix} \mathbf{K}^s & \mathbf{0} \\ \mathbf{0} & \mathbf{0} \end{bmatrix} \begin{bmatrix} \psi \mathbf{v}_w \\ \psi \mathbf{v}_{\Omega} \end{bmatrix} \right\} dz \quad (16)
\end{aligned}$$

Besides the global stiffness matrices  $\mathbf{K}$  in equation (16), a bold zero  $\mathbf{0}$  denotes here and in the following a suitable size matrix or vector of zeroes.

Let us also perform the same operations with the initial stress contribution to the potential energy. The introduction of the displacement interpolations leads to the definition of the geometric stiffness matrix for a single wall element as follows:

$$\begin{aligned}
\mathbf{k}^0 &= \int_0^{b_e} \left\{ t\sigma^0 [\mathbf{N}_n^T \mathbf{N}_n] \right. \\
& \left. + t\sigma^0 [\mathbf{N}_s^T \mathbf{N}_s] + \frac{1}{12}t^3\sigma^0 [\mathbf{N}_{n,s}^T \mathbf{N}_{n,s}] \right\} dz \quad (17)
\end{aligned}$$

Transforming from local,  $\mathbf{v}_w^{el}$ , to global,  $\mathbf{v}_w$ , components using a standard formal finite element transformation and assembly matrix  $\mathbf{T}_w$  we get the following global geometrical stiffness matrix:

$$\mathbf{K}^0 = \sum_{el} \mathbf{T}_w^T \mathbf{k}^0 \mathbf{T}_w \quad (18)$$

Hereby equation (15) in reduced form can be rewritten as

$$\begin{aligned}
\Pi_0 &= \frac{1}{2} \int_0^L \left\{ \left[ \psi \mathbf{v}_w^T \quad \psi \mathbf{v}_{\Omega}^T \right]' \begin{bmatrix} \lambda \mathbf{K}^0 & \mathbf{0} \\ \mathbf{0} & \mathbf{0} \end{bmatrix} \begin{bmatrix} \psi \mathbf{v}_w \\ \psi \mathbf{v}_{\Omega} \end{bmatrix}' \right\} dz \\
& \quad (19)
\end{aligned}$$

which is the contribution to the potential energy from the factored initial stress.

#### 4. GBT differential equations with initial stress

To obtain a formulation resembling a generalization of Vlasov beam theory including distortion, the following main steps need to be performed as in the related papers [15] and [16].

##### 4.1. Step I: Pure axial extension and influence of shear constraints

In this step, we introduce the shear constraint equations that bind axial and transverse modes together and at the same time simplify or condense equation (16). In this process we need to eliminate the singularity in

the shear stiffness matrix related to pure axial extension. Performing step I as in the related papers the differential equations governing the stability problem can be derived by considering the first variation of the initial stress contributions to the potential energy in the same way as the first variation of the traditional elastic potential energy provided the differential equations in the related papers [15] and [16].

$$\delta\Pi_0 = \int_0^L \left\{ \delta(\psi \mathbf{v}_w^T)' \lambda \mathbf{K}^0 (\psi \mathbf{v}_w)' \right\} dz \quad (20)$$

After performing partial integration the variation of the initial stress contributions to the potential energy take the form:

$$\delta\Pi_0 = \int_0^L \left\{ \delta(\psi \mathbf{v}_w^T) \left[ -(\lambda \mathbf{K}^0 \mathbf{v}_w \psi)' \right] \right\} ds + \left[ \delta(\psi \mathbf{v}_w^T) \left[ \lambda \mathbf{K}^0 (\psi \mathbf{v}_w)' \right] \right]_0^L \quad (21)$$

where the term in the square bracket correspond to the boundary loads and boundary conditions. As in the related paper [15] the pure axial displacement mode is identified and denoted by superscript  $a$  and the remaining axial displacement modes by superscript  $r$ . Substituting  $\delta\Pi_{int}$  from the related paper leads to the following coupled homogeneous differential equations of GBT including initial stresses in which we note that  $\zeta = -\psi'$ :

$$\left( \bar{\mathbf{K}}^\sigma \mathbf{v}_w \psi'' \right)'' - \left( \mathbf{K}_{\Omega\Omega}^{\sigma ra} v_{\Omega\zeta}^a \zeta' \right)'' - \left( \left[ \mathbf{K}^\tau \mathbf{v}_w + \lambda \mathbf{K}^0 \mathbf{v}_w \right] \psi' \right)' + \mathbf{K}^s \mathbf{v}_w \psi = \mathbf{0} \quad (22)$$

$$\left( \mathbf{K}_{\Omega\Omega}^{\sigma ar} \mathbf{v}_w \psi'' \right)' - \left( \mathbf{K}_{\Omega\Omega}^{\sigma aa} v_{\Omega\zeta}^a \zeta' \right)' = \mathbf{0} \quad (23)$$

These equations establish a coupled set of homogeneous GBT differential equations, that determine the displacements of a thin-walled beam for a given set of boundary conditions. Note that  $v_{\Omega\zeta}^a$  is one component that corresponds to the amount of pure axial extension.

Now we seek solutions to the equations. As in paper [15] we can identify pure axial extension as a solution which takes the form

$$\begin{aligned} \zeta(z) &= -\psi'(z) = c_{a1} + c_{a2}z \\ &= -\Psi_a'(z) \mathbf{c}_a = \begin{bmatrix} 1 & z \end{bmatrix} \begin{bmatrix} c_{a1} \\ c_{a2} \end{bmatrix} \end{aligned} \quad (24)$$

where  $c_{a1}$  and  $c_{a2}$  are constants determined by the boundary conditions of axial extension.

Having identified the “trivial” displacement mode, pure axial extension, we turn to the solution of the transverse displacement modes. Eliminating  $\zeta''$  by using the fact that  $\zeta'' = -\psi'''$  and assuming that  $\psi''' \neq 0$ , we find:

$$v_{\Omega}^a = -(\mathbf{K}_{\Omega\Omega}^{\sigma aa})^{-1} \mathbf{K}_{\Omega\Omega}^{\sigma ar} \mathbf{v}_w \quad (25)$$

Using this equation or equation (23), we eliminate the second term in equation (22). This results in the following homogeneous fourth order differential equations for determination of the transverse (global, distortional and local) distortional displacement modes of GBT:

$$\mathbf{K}^\sigma \mathbf{v}_w \psi'''' - \left( \left[ \mathbf{K}^\tau + \lambda \mathbf{K}^0 \right] \mathbf{v}_w \psi' \right)' + \mathbf{K}^s \mathbf{v}_w \psi = \mathbf{0} \quad (26)$$

where  $\mathbf{K}^\sigma$ ,  $\mathbf{K}^\tau$  and  $\mathbf{K}^s$  which are constants are given in the related paper [15]. In general  $\mathbf{K}^0$  is a function of the axial coordinate  $z$  corresponding to the longitudinal contribution of the initial stress. However in the present context the initial stress will be assumed uniformly distributed and constant whereby  $\mathbf{K}^0$  is also independent of the axial coordinate  $z$  and the equation simplifies to

$$\mathbf{K}^\sigma \mathbf{v}_w \psi'''' - \left[ \mathbf{K}^\tau + \lambda \mathbf{K}^0 \right] \mathbf{v}_w \psi'' + \mathbf{K}^s \mathbf{v}_w \psi = \mathbf{0} \quad (27)$$

This set of GBT column stability equations resemble the conventional equation for classic column stability. Now the number of degrees of freedom is  $n_{dof} = 3n_{no}$ , since all ( $n_{no}$ ) axial dofs  $\mathbf{v}_{\Omega}$  have been eliminated by the shear constraint equation and the pure axial deformation mode.

#### 4.2. Step II: Translations, constant wall width and reduction of order

In this step we treat two modes corresponding to transverse translations of the cross section and one mode corresponding to pure rotation. We also constrain the transverse displacement field so that the wall widths remain constant, i.e. we enforce  $w_{s,s} \equiv 0$ .

Let us do this by first using the following transformation fully described in [15]:

$$\mathbf{v}_w = \begin{bmatrix} \mathbf{T}_w^\alpha & \mathbf{T}_w^3 & \tilde{\mathbf{T}}_w^\mu \end{bmatrix} \begin{bmatrix} \mathbf{v}_w^\alpha \\ v_w^3 \\ \mathbf{v}_w^\mu \end{bmatrix} \quad (28)$$

Here the two orthogonal translational eigenmodes are ordered in the transformation matrix  $\mathbf{T}_w^\alpha$  and the orthogonal pure rotational eigenmode in  $\mathbf{T}_w^3$ . The identification of the constrained degrees of freedom to be eliminated is performed by a transformation matrix  $\mathbf{T}_w^c$  while the remaining unconstrained degrees of freedom

are identified in the transformation matrix  $\mathbf{T}_w^u$ . By expressing the constrained degrees of freedom by the unconstrained we find the total condensed transformation introduced as  $\tilde{\mathbf{T}}_w^u$ , as derived in [15].

Using this transformation to transform the differential equations in (27), and introducing the null terms corresponding to the rigid-body modes and zero shear strain for translational and flexural modes, the differential equations take the following form:

$$\begin{aligned} & \begin{bmatrix} \mathbf{K}_{\alpha\alpha}^\sigma & \mathbf{0} & \mathbf{K}_{\alpha u}^\sigma \\ \mathbf{0} & K_{33}^\sigma & \mathbf{K}_{3u}^\sigma \\ \mathbf{K}_{u\alpha}^\sigma & \mathbf{K}_{u3}^\sigma & \mathbf{K}_{uu}^\sigma \end{bmatrix} \begin{bmatrix} \mathbf{v}_w^\alpha \psi \\ v_w^3 \psi \\ \mathbf{v}_w^u \psi \end{bmatrix} \psi'''' \\ & - \left( \begin{bmatrix} \mathbf{0} & \mathbf{0} & \mathbf{0} \\ \mathbf{0} & K_{33}^\tau & \mathbf{K}_{3u}^\tau \\ \mathbf{0} & \mathbf{K}_{u3}^\tau & \mathbf{K}_{uu}^\tau \end{bmatrix} + \lambda \begin{bmatrix} \mathbf{K}_{\alpha\alpha}^0 & \mathbf{K}_{\alpha 3}^0 & \mathbf{K}_{\alpha u}^0 \\ \mathbf{K}_{3\alpha}^0 & K_{33}^0 & \mathbf{K}_{3u}^0 \\ \mathbf{K}_{u\alpha}^0 & \mathbf{K}_{u3}^0 & \mathbf{K}_{uu}^0 \end{bmatrix} \right) \begin{bmatrix} \mathbf{v}_w^\alpha \psi \\ v_w^3 \psi \\ \mathbf{v}_w^u \psi \end{bmatrix} \psi'' \\ & + \begin{bmatrix} \mathbf{0} & \mathbf{0} & \mathbf{0} \\ \mathbf{0} & \mathbf{0} & \mathbf{0} \\ \mathbf{0} & \mathbf{0} & \mathbf{K}_{uu}^s \end{bmatrix} \begin{bmatrix} \mathbf{v}_w^\alpha \psi \\ v_w^3 \psi \\ \mathbf{v}_w^u \psi \end{bmatrix} \psi = \begin{bmatrix} \mathbf{0} \\ \mathbf{0} \\ \mathbf{0} \end{bmatrix} \end{aligned} \quad (29)$$

The transformed stiffness matrices are found and described in paper [15] and the  $\mathbf{K}^0$ -matrices are given in Table 2. Now the number of degrees of freedom depends on the geometry of the cross section. We have constrained the transverse displacement field so that the wall widths remain constant, i.e. we enforce  $w_{s,s} \equiv 0$ . This means that a single  $w_s$ -dof is eliminated for each element in the cross section. For a lipped channel cross section with  $n_{el} = n_{no} - 1$  elements this means that  $n_{dof} = 3n_{no} - n_{el} = 2n_{no} + 1$ . For a box cross section with  $n_{el} = n_{no}$  elements it means that  $n_{dof} = 3n_{no} - n_{el} = 2n_{no}$ .

To solve this differential equation we choose to reduce the differential order of the coupled fourth-order differential equations and the related quadratic eigenvalue problem to twice as many coupled second-order differential equations with a related linear eigenvalue problem of double size. This is done in the following. This method is equivalent to the one used for the solution of the coupled homogeneous problem of one-mode distortion and torsion analyzed in [23].

The fourth order differential equation (29) can be transformed into twice as many second order differential equations by introducing what is called a state vector. There are a number of different possible formulations, but we have chosen the use of the state vector  $\mathbf{u}_S = [\mathbf{v}_w^\alpha \psi, v_w^3 \psi, \mathbf{v}_w^u \psi, \mathbf{v}_w^\alpha \psi'', v_w^3 \psi'', \mathbf{v}_w^u \psi'']^T$ . Introducing this state vector (and using related equality block equations) yields a reformulation of equation (29) as a formal second order matrix differential equation of dou-

ble size which takes the form:

$$\begin{aligned} & \begin{bmatrix} \mathbf{0} & \mathbf{0} & \mathbf{0} & \mathbf{0} & \mathbf{0} & \mathbf{0} \\ \mathbf{0} & \mathbf{0} & \mathbf{0} & \mathbf{0} & \mathbf{0} & \mathbf{0} \\ \mathbf{0} & \mathbf{0} & \mathbf{K}_{uu}^s & \mathbf{0} & \mathbf{0} & \mathbf{0} \\ \dots & \dots & \dots & \dots & \dots & \dots \\ \mathbf{0} & \mathbf{0} & \mathbf{0} & -\mathbf{K}_{\alpha\alpha}^\sigma & \mathbf{0} & -\mathbf{K}_{\alpha u}^\sigma \\ \mathbf{0} & \mathbf{0} & \mathbf{0} & \mathbf{0} & -K_{33}^\sigma & -\mathbf{K}_{3u}^\sigma \\ \mathbf{0} & \mathbf{0} & \mathbf{0} & -\mathbf{K}_{u\alpha}^\sigma & -\mathbf{K}_{u3}^\sigma & -\mathbf{K}_{uu}^\sigma \end{bmatrix} \begin{bmatrix} \mathbf{v}_w^\alpha \psi \\ v_w^3 \psi \\ \mathbf{v}_w^u \psi \\ \dots \\ \mathbf{v}_w^\alpha \psi'' \\ v_w^3 \psi'' \\ \mathbf{v}_w^u \psi'' \end{bmatrix} - \\ & \left( \begin{bmatrix} \mathbf{0} & \mathbf{0} & \mathbf{0} & -\mathbf{K}_{\alpha\alpha}^\sigma & \mathbf{0} & -\mathbf{K}_{\alpha u}^\sigma \\ \mathbf{0} & K_{33}^\tau & \mathbf{K}_{3u}^\tau & \mathbf{0} & -K_{33}^\sigma & -\mathbf{K}_{3u}^\sigma \\ \mathbf{0} & \mathbf{K}_{u3}^\tau & \mathbf{K}_{uu}^\tau & -\mathbf{K}_{u\alpha}^\sigma & -\mathbf{K}_{u3}^\sigma & -\mathbf{K}_{uu}^\sigma \\ \dots & \dots & \dots & \dots & \dots & \dots \\ -\mathbf{K}_{\alpha\alpha}^\sigma & \mathbf{0} & -\mathbf{K}_{\alpha u}^\sigma & \mathbf{0} & \mathbf{0} & \mathbf{0} \\ \mathbf{0} & -K_{33}^\sigma & -\mathbf{K}_{3u}^\sigma & \mathbf{0} & \mathbf{0} & \mathbf{0} \\ -\mathbf{K}_{u\alpha}^\sigma & -\mathbf{K}_{u3}^\sigma & -\mathbf{K}_{uu}^\sigma & \mathbf{0} & \mathbf{0} & \mathbf{0} \end{bmatrix} + \right. \\ & \left. \lambda \begin{bmatrix} \mathbf{K}_{\alpha\alpha}^0 & \mathbf{K}_{\alpha 3}^0 & \mathbf{K}_{\alpha u}^0 & \mathbf{0} & \mathbf{0} & \mathbf{0} \\ \mathbf{K}_{3\alpha}^0 & K_{33}^0 & \mathbf{K}_{3u}^0 & \mathbf{0} & \mathbf{0} & \mathbf{0} \\ \mathbf{K}_{u\alpha}^0 & \mathbf{K}_{u3}^0 & \mathbf{K}_{uu}^0 & \mathbf{0} & \mathbf{0} & \mathbf{0} \\ \dots & \dots & \dots & \dots & \dots & \dots \\ \mathbf{0} & \mathbf{0} & \mathbf{0} & \mathbf{0} & \mathbf{0} & \mathbf{0} \\ \mathbf{0} & \mathbf{0} & \mathbf{0} & \mathbf{0} & \mathbf{0} & \mathbf{0} \\ \mathbf{0} & \mathbf{0} & \mathbf{0} & \mathbf{0} & \mathbf{0} & \mathbf{0} \end{bmatrix} \right) \begin{bmatrix} \mathbf{v}_w^\alpha \psi \\ v_w^3 \psi \\ \mathbf{v}_w^u \psi \\ \dots \\ \mathbf{v}_w^\alpha \psi'' \\ v_w^3 \psi'' \\ \mathbf{v}_w^u \psi'' \end{bmatrix} = \begin{bmatrix} \mathbf{0} \\ \mathbf{0} \\ \mathbf{0} \\ \dots \\ \mathbf{0} \\ \mathbf{0} \\ \mathbf{0} \end{bmatrix} \end{aligned} \quad (30)$$

which we choose to abbreviate as follows using the block structure shown in equation (30):

$$\begin{aligned} & \begin{bmatrix} \tilde{\mathbf{K}}^s & \mathbf{0} \\ \mathbf{0} & -\tilde{\mathbf{K}}^\sigma \end{bmatrix} \begin{bmatrix} \tilde{\mathbf{v}}_w \psi \\ \tilde{\mathbf{v}}_w \psi'' \end{bmatrix} \\ & - \left( \begin{bmatrix} \tilde{\mathbf{K}}^\tau & -\tilde{\mathbf{K}}^\sigma \\ -\tilde{\mathbf{K}}^\sigma & \mathbf{0} \end{bmatrix} + \lambda \begin{bmatrix} \tilde{\mathbf{K}}^0 & \mathbf{0} \\ \mathbf{0} & \mathbf{0} \end{bmatrix} \right) \begin{bmatrix} \tilde{\mathbf{v}}_w \psi \\ \tilde{\mathbf{v}}_w \psi'' \end{bmatrix} = \begin{bmatrix} \mathbf{0} \\ \mathbf{0} \end{bmatrix} \end{aligned} \quad (31)$$

This is the set of differential equations to which we want to find solutions.

## 5. The distortional initial stress eigenvalue problem

In the reduced order differential equations in (31) we substitute  $\mathbf{A}$ ,  $\mathbf{B}$ ,  $\mathbf{C}$  and  $\mathbf{u}_S$  for the respective matrices and vector in the equation. This means that  $\mathbf{A}$  and  $\mathbf{B}$  are linear stiffness matrices,  $\mathbf{C}$  a geometrical stiffness matrix and  $\mathbf{u}_S$  a vector containing the longitudinal amplitude functions. Thus it takes the following form:

$$\mathbf{A}\mathbf{u}_S - [\mathbf{B} + \lambda\mathbf{C}]\mathbf{u}_S'' = \mathbf{0} \quad (32)$$

This set of differential equations are homogeneous with constant coefficients and therefore lead to solution functions of exponential type.

By postulating exponential solutions of the form  $\mathbf{u}_S = \mathbf{v}_S \psi(z)$ , where the state space vector  $\mathbf{v}_S$  is independent



$\mathbf{K}_{\alpha\alpha}^0 = \mathbf{T}_w^\alpha T \mathbf{K}^0 \mathbf{T}_w^\alpha$	$\mathbf{K}_{\alpha 3}^0 = \mathbf{T}_w^\alpha T \mathbf{K}^0 \mathbf{T}_w^3$	$K_{\alpha u}^0 = \mathbf{T}_w^\alpha T \mathbf{K}^0 \mathbf{T}_w^u$
$\mathbf{K}_{3\alpha}^0 = \mathbf{T}_w^3 T \mathbf{K}^0 \mathbf{T}_w^\alpha$	$K_{33}^0 = \mathbf{T}_w^3 T \mathbf{K}^0 \mathbf{T}_w^3$	$\mathbf{K}_{3u}^0 = \mathbf{T}_w^3 T \mathbf{K}^0 \widetilde{\mathbf{T}}_w^u$
$\mathbf{K}_{u\alpha}^0 = \widetilde{\mathbf{T}}_w^u T \mathbf{K}^0 \mathbf{T}_w^\alpha$	$\mathbf{K}_{u3}^0 = \widetilde{\mathbf{T}}_w^u T \mathbf{K}^0 \mathbf{T}_w^3$	$\mathbf{K}_{uu}^0 = \widetilde{\mathbf{T}}_w^u T \mathbf{K}^0 \widetilde{\mathbf{T}}_w^u$

Table 2: Transformation of  $K^0$ -stiffness matrices related to Step II.

of the axial coordinate  $z$  and  $\psi(z) = e^{\xi z}$ , and inserting the solution the following special eigenvalue problem is obtained:

$$\mathbf{A} \mathbf{v}_S - \xi^2 [\mathbf{B} + \lambda \mathbf{C}] \mathbf{v}_S = \mathbf{0} \quad (33)$$

In the classic stability theory the solution function  $\psi(z)$  is normally assumed to be a trigonometric function in order to satisfy suitable simple boundary conditions, see [24]. This means that  $\xi = \mu i$  is a known (complex) parameter and that  $\lambda$  can be determined as the eigenvalue equivalent to the instability load factor, which determines the level of stress at which the structure becomes unstable. The eigenvalues and the corresponding eigenvectors  $\mathbf{v}_S$  can be found by solving the eigenvalue problem.

In order to satisfy suitable simple boundary conditions let us therefore assume that the solution is of a simple trigonometric form here chosen as

$$\psi(z) = \sin \mu z \quad (34)$$

where  $\mu = n\pi/L$  in which  $n$  is equal to the number of buckles, i.e. half-wavelengths. This solution satisfies boundary conditions corresponding to simple supports with restrained transverse cross-section displacements at  $z = 0$  and  $z = L$ . Inserting this postulated solution in equation (32) and remembering the change of sign related to double differentiation of the sine function leads to the following generalized linear symmetric matrix eigenvalue problem, in which the eigenvalues,  $\lambda$ , correspond to the buckling factor and the eigenvectors are the distortional state space buckling modes:

$$\left[ \mathbf{A} + \left( \frac{n\pi}{L} \right)^2 \mathbf{B} \right] \mathbf{v}_S + \lambda \left( \frac{n\pi}{L} \right)^2 \mathbf{C} \mathbf{v}_S = \mathbf{0} \quad (35)$$

Eliminating the second half of vector  $\mathbf{v}_S$  corresponding to  $\tilde{\mathbf{v}}_w \psi''$  in equation (31) leads to the following final generalized linear symmetric matrix eigenvalue problem:

$$[\mathbf{K} + \lambda \mathbf{G}] \tilde{\mathbf{v}}_w = \mathbf{0} \quad (36)$$

in which  $\mathbf{K}$  and  $\mathbf{G}$  are given in Table 3 as functions of the inverse length scale parameter  $\mu$ .

$$\mathbf{K} = \widetilde{\mathbf{K}}^s + \mu^2 \widetilde{\mathbf{K}}^\tau + \mu^4 \widetilde{\mathbf{K}}^\sigma \quad \mathbf{G} = \mu^2 \widetilde{\mathbf{K}}^0$$

Table 3: Definition of  $\mathbf{K}$  and  $\mathbf{G}$ .

From the results of this eigenvalue problem we know at which load ( $\lambda$ ) the corresponding mode has a homogeneous solution function which is sinusoidal with a number of half-waves corresponding to  $n$ . Here the number of degrees of freedom for a lipped channel cross section is  $n_{dof} = 2n_{no} + 1$ , while the number of degrees of freedom for a box cross section is  $n_{dof} = 2n_{no}$ . The number of dofs is equal to the number of eigenvalues. In the following we will see this applied in the examples.

## 6. Examples

In this section the developed GBT approach is used to give illustrative examples of the trigonometric buckling solutions of the differential GBT equations with initial stress. The ability of the GBT approach to produce buckling curves and predict buckling is shown. The examples consider simply supported columns in uniform compression. The end sections are constrained against transverse displacements, but otherwise free to warp (and thus also rotate). The two examples are based on a lipped channel section and a rectangular hollow section, respectively.

In each example the buckling signature curves of the cross section are developed corresponding to the buckling stress versus the buckling half-wavelength for the four lowest buckling modes. This is done by solving the GBT eigenvalue problem for consecutive values of the half-wavelength. For each buckling curve it is shown that the transverse buckling mode shape varies with the buckle half-wavelength. The buckling signature curve is used to develop the overall buckling curve including multiple buckling waves by shifting the signature curve sides ways corresponding to a number of half-wavelengths. Chosen buckling modes for given column lengths are used to illustrate local, distortional and global buckling modes. The accuracy of the results are

assessed by comparison to results obtained by the use of the commercial FE program Abaqus.

The results found using Abaqus are based on isotropic material and the 4 node S4 shell element with full 4 point integration. The linear elastic finite element calculations are based on a structured rectangular mesh with a side length seed of 5 mm. The cross section is fixed in the transverse directions at both ends and fixed at one node against longitudinal translation. All supports are continuous line supports. Two identical normal forces are applied as a uniform distributed shell edge load; one at each end. For further and more detailed explanations see also [20]. This finite element model results in local transverse stress near the end supports due to the Poisson effect. These end stresses have an influence on the buckling, which is not included in the FSM or GBT models.

### 6.1. Example 1: Buckling of a lipped channel column

In this example the buckling of a simply supported lipped channel column in pure compression is analyzed. The chosen in-plane geometry and the discretization is shown in Figure 4. Solving the GBT initial stress eigen-

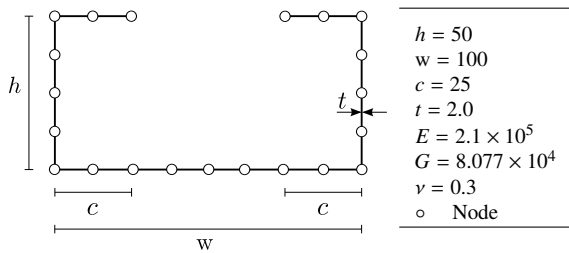

Figure 4: Geometry, discretization and parameter values of a lipped channel column.

value problem given in equation (35) with  $n=1$  for half-wavelengths  $L$  varying from 10 mm to 3000 mm (logarithmical spaced) allows the development of the signature curve (buckling stress versus the buckle half wavelength) as shown in Figure 5. Thus the buckling curves shown in the figure correspond to the four lowest buckling modes with one half-wave buckle,  $n = 1$ . For three different half-wavelengths the transverse buckling mode shape has been included in the figure. It is clear that the mode shape of each curve changes gradually as a function of the length. The chosen half-wavelengths correspond to the dashed lines at 70 mm, 500 mm and 2000 mm, respectively. To illuminate the changes in the deformation modes for increasing length we have chosen also to show the buckling mode shapes in 3D in Figure 6. The mode shapes are shown as a 3D rep-

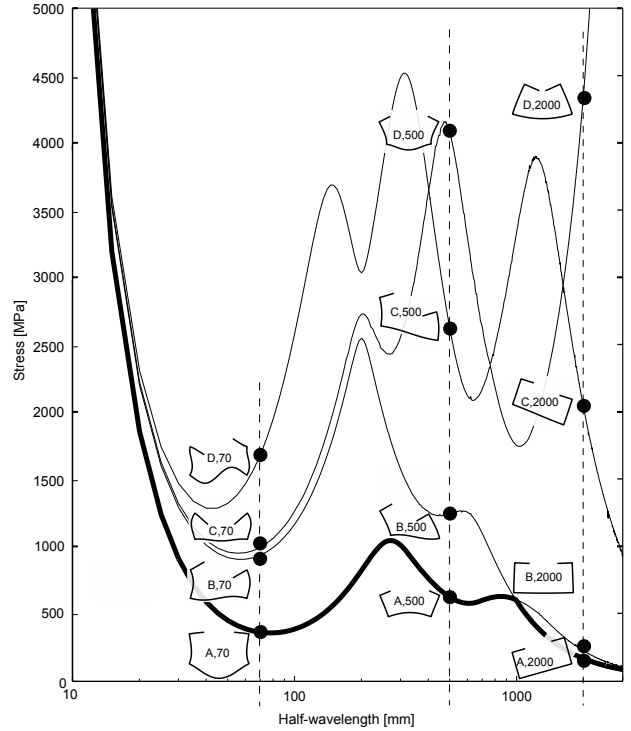

Figure 5: Buckling signature curve corresponding to the lowest four modes with a single half-wave buckle,  $n=1$ .

resentation even though the results are provided by a one-dimensional beam formulation.

From the figures it is seen that each developing mode represents its own curve placed in a hierarchical order according to the stress level. However, the curves are able to change place in the hierarchy at a certain column length. This phenomenon can for example be seen for buckling mode 1 and 2 (two lowest ranking graphs) at a column length of approximately 1000 mm. The signature curve, shown bold, is achieved as the the very lowest of the buckling curves. For this curve a short column lengths correspond to local buckling, while for increasing column lengths it corresponds to distortional buckling and finally for large column lengths it corresponds to global buckling. The signature curve is similar to the finite strip buckling curve obtained by Hancock [25].

As mentioned Figure 5 is for a half-wave number  $n = 1$ . As the buckling loads also depend on the number of  $n$  half waves in the buckled shapes, this means that points lower than the signature curve can exist for a greater number of buckles,  $n > 1$ . To show this phenomenon the signature curve has been created for a varying number of  $n$  as shown in Figure 7. This means that the bold curve shown in Figure 7 represents the absolute lowest curve for the buckling stress versus

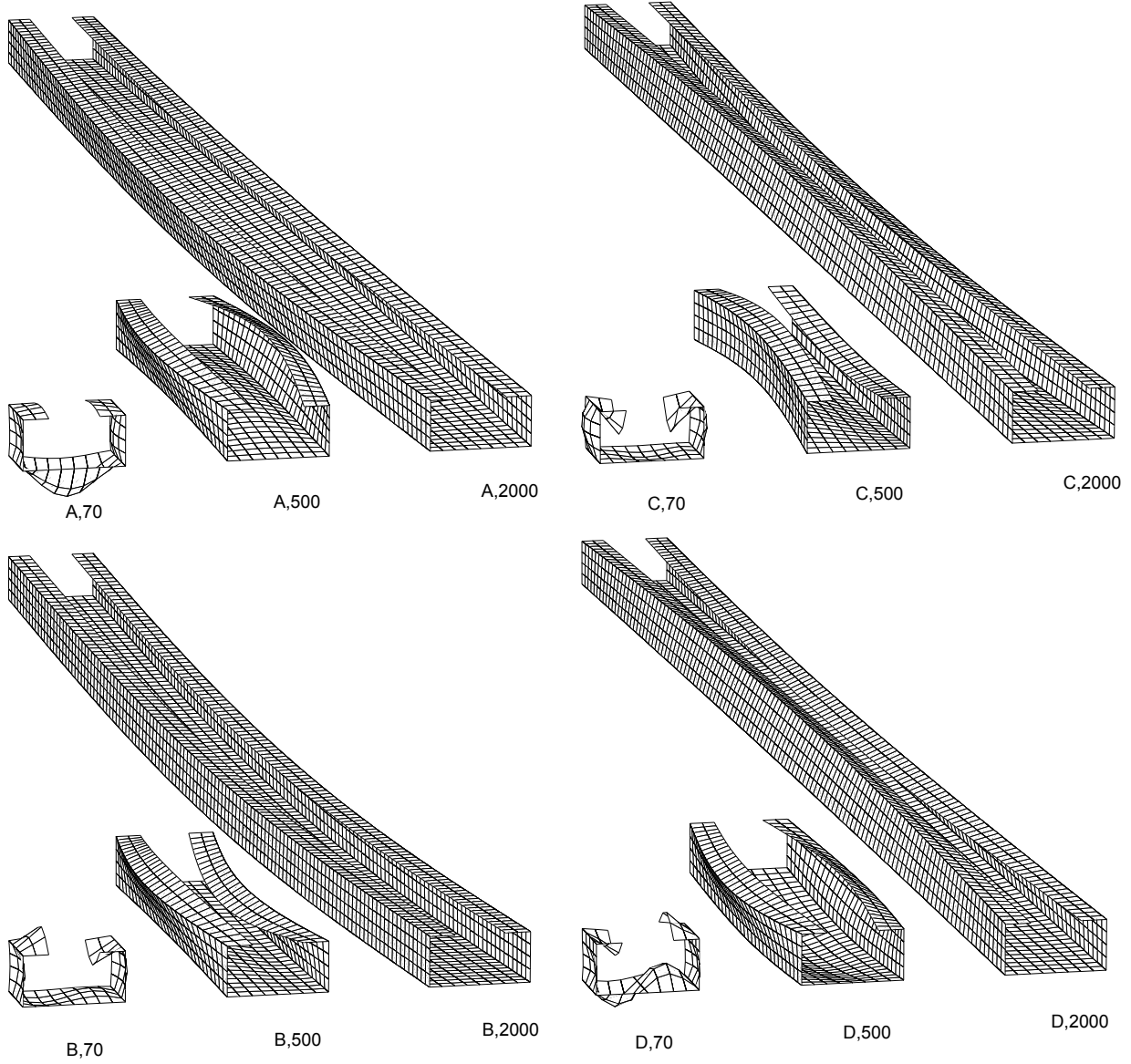

Figure 6: Column buckling modes associated with Figure 5 for single ( $n = 1$ ) half wavelengths of 70 mm, 500 mm and 2000 mm

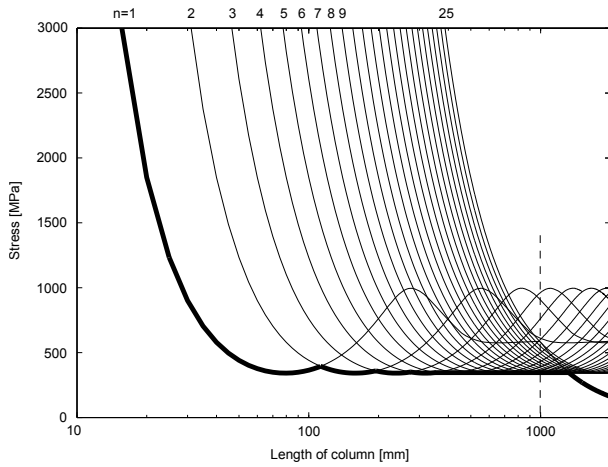

Figure 7: Buckling stress versus column length for the lipped channel section in compression.

column length. However, to illustrate the multitude of buckling modes for each column length, let us look at a column length of  $L = 1000\text{mm}$ . In Figure 7 this length is represented by the vertical dashed line. For this length we can find the buckling modes  $m = 1, 2, 3..$  ordered from lowest to highest critical stress, each having a different number of half waves  $n$ .

In Table 4 the buckling stresses of FE analysis using Abaqus [20] versus the presented GBT method, conventional GBT using GBTUL [22] and FSM using CUFSM [21] are compared. The comparison is performed for suitable mode numbers ( $m$ -values) and the associated relevant buckling modes are depicted in Figure 8, which shows the local buckling mode corresponding to the lowest critical stress ( $m=1$ ), the global beam buckling mode ( $m=20$ ) and a distortional mode shape ( $m=24$ ), respectively. The three values of  $m$  have been chosen to show the spectrum of modes represented at the given beam length.

From Table 4 it is seen that for a column length of 1000 mm buckling will occur as local buckling consisting of thirteen sine half waves and have an associated buckling stress of 350 MPa. Further more it is seen that the buckling mode shape for mode  $m = 20$  is global column buckling with one buckle,  $n = 1$ , at a stress level of 590 Mpa and finally for  $m = 24$  distortional column buckling occurs at a stress level of 918 Mpa.

Comparing the GBT buckling stresses with Abaqus we obtain a deviation of 13.4 % for local plate buckling, 1.7 % for global buckling and 1.7 % for distortional buckling. Hereby it is seen that good results are obtained for global and distortional buckling, while a rather large deviation is obtained for local buckling.

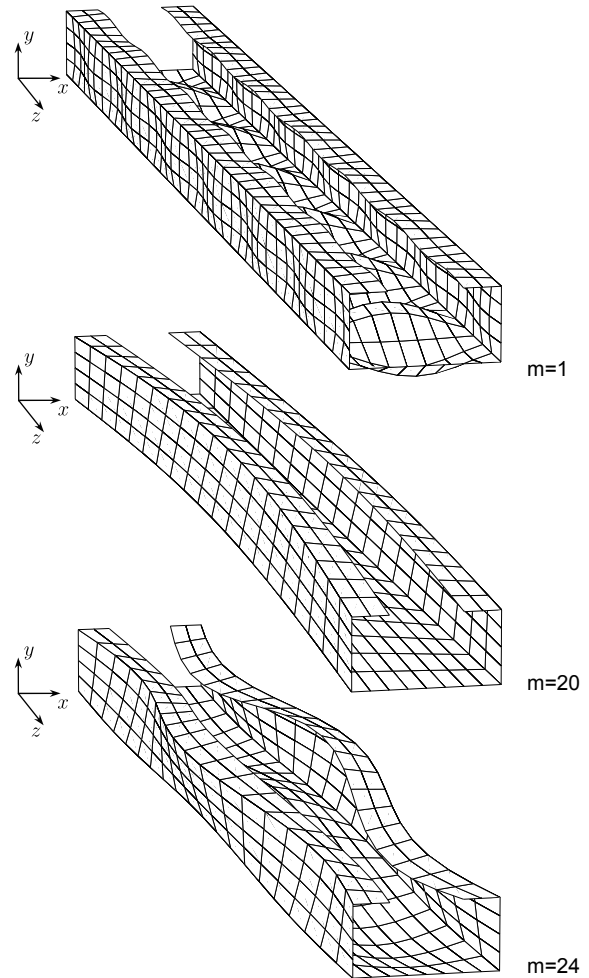

Figure 8: GBT column buckling mode shapes of a lipped channel column in pure compression.

m	Nr. of half waves n	Abaqus [MPa]	GBT [MPa]	Diff. %	GBTUL [MPa]	Diff. %	CUFSM [MPa]	Diff. %
1	13	404	350	13.4	436	7.9	412	2.0
20	1	580	590	1.7	589	1.6	581	0.2
24	3	903	918	1.7	–	–	906	0.3

Table 4: Comparison of buckling stresses for FE analysis versus the presented GBT method, GBTUL and CUFSM, respectively. The comparisons are related to the vertical dashed m-line in Figure 7.

The same phenomenon is seen from the GBTUL results which are based on the classic GBT theory. Here a deviation of 7.9 % is obtained for local plate buckling and 1.6 % for global buckling. In contrast to these beam theory results, Table 4 also shows results obtained from the CUFSM program which is based on a plate theory. Here we obtain a deviation of 2.0 % for local plate buckling, 0.2 % for global buckling and 0.3 % for distortional buckling, showing that good results are obtained in all cases. From the deviations it is obvious that GBT and GBTUL are based on beam theories while CUFSM is based on plate theory. The rather large deviation of 13.4 % for the GBT results compared with the deviation of 7.9 % obtained with GBTUL, can to a certain extent be explained by the very simple constitutive relations used in the current GBT formulation. Making a calculation in Abaqus with similar very simple non-coupling constitutive relations the deviations obtained now corresponds to (350 MPa) 0.0%, (582 MPa) 1.4% and (888 MPa) 3.4%, respectively. Hereby good matches between the two approaches are obtained, however also difference in the modeling of the boundary conditions can affect the results. Thus demonstrating that this new developed GBT approach provides reasonably accurate results with a very small computational cost, making it an alternative to the traditional and time consuming FE calculations and the other available methods. However the constitutive relations should be modified to achieve a higher accuracy for local plate buckling.

## 6.2. Example 2: Buckling of a rectangular hollow section column

In this example a simply supported rectangular hollow section (RHS) column is analyzed. The discretization of the cross section and the used parameters are as given in Figure 9. Considering the given cross section and solving the eigenvalue problem in equation (35) the buckling signature curves can be established as depicted in Figure 10. The buckling curves depicted corresponds to the lowest four buckling modes with a single half-wave buckle,  $n = 1$ . In this example we have chosen to show the buckling mode shapes of the four lowest

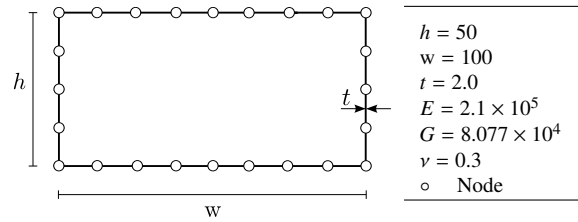

Figure 9: Geometry and parameter values of a rectangular hollow section column.

curves. The mode shapes are shown for two values of the half-wave buckling length corresponding to 200 mm and 900 mm, respectively. The corresponding 3D plots of the column buckling mode shapes are shown in Figure 11. From the figures it is seen that each developing mode represents its own curve placed in a hierarchical order according to the stress level. Also here it is seen that the curves are able to change place in the hierarchy. Looking at the very lowest curve (the signature curve) shown as the bolded curve it is seen that short column length corresponds to local buckling, while larger column lengths correspond to global buckling.

As mentioned Figure 10 is for a half-wave number of  $n = 1$ . To show the signature curve for a varying number of  $n$  half waves in the buckled shapes Figure 13 has been created. This means that Figure 13 represent the absolute lowest curve for the buckling stress versus column length for the section given in Figure 9. To illustrate the multitude of buckling modes for a given column length let us look at a column length of  $L = 1000$  mm. For this length we look at the ordered buckling modes,  $m = 1, 2, 3..$  each having a different number of half-wave buckles. In Figure 13 this length is represented by the vertical dashed line.

In Table 5 the buckling stresses of FE analysis [20] versus the presented GBT method and FSM using CUFSM [21] are compared for suitable  $m$ -values. Furthermore the associated relevant buckling configurations are depicted in Figure 12 representing a local buckling at the lowest critical stress ( $m=1$ ) and a global buckling ( $m=22$ ). The two values of  $m$  have been cho-

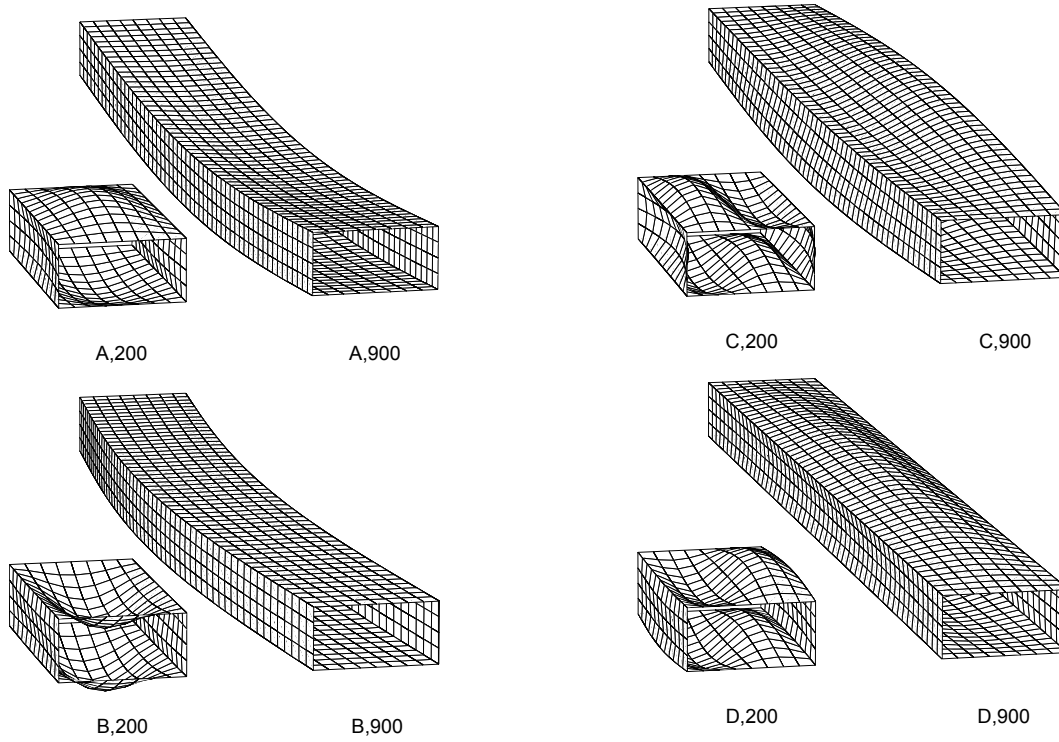

Figure 11: Column buckling modes associated with Figure 10 for single ( $n = 1$ ) half wavelengths of 200 mm and 900 mm.

m	Nr. of half waves		Abaqus [MPa]	GBT [MPa]	Diff. %	CUFSM [MPa]	Diff. %
	n						
1	12		384	330	14.1	391	1.8
22	1		947	987	4.2	940	0.7

Table 5: Comparison of buckling stresses for FE analysis versus the presented GBT method and CUFSM, respectively. The comparisons are related to the vertical dashed m-line in Figure 13.

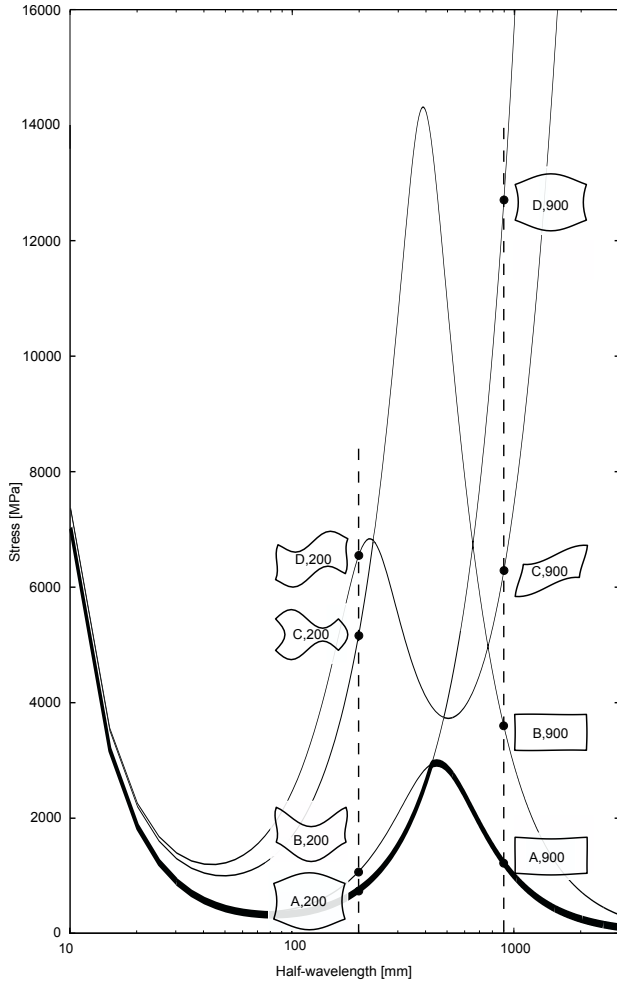

Figure 10: Buckling signature curve corresponding to the lowest four modes with a single half-wave buckle,  $n=1$ .

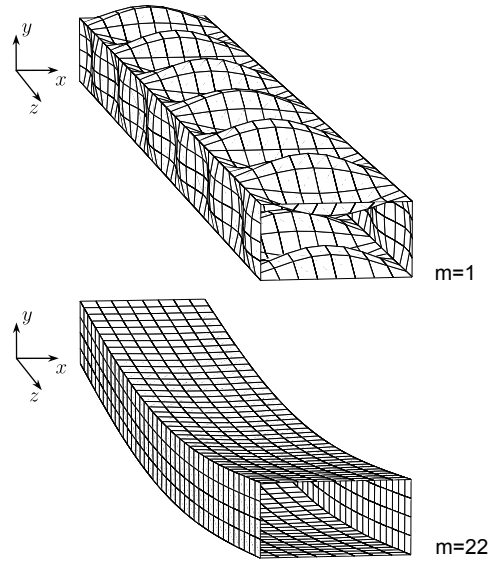

Figure 12: GBT column buckling mode shapes of a rectangular hollow section column in pure compression.

sen to show the spectrum of modes represented at a given column length. Comparing the buckling stresses corresponding to the figures in Figure 12 with the commercial FE program Abaqus a maximum deviation of 14.1% is obtained for the first buckling mode ( $m=1$ ) corresponding to local plate buckling while a deviation of 4.2% is obtained for  $m$  equal to 22 corresponding to global column buckling with some distortion included. Also here it is seen that good results are obtained for global buckling while a rather large deviation is obtained for local buckling. Using the CUFMS software we obtain FSM results with a deviation of 1.8% for local plate buckling and 0.7% for global buckling which confirms good results in both cases. From the given deviations it is clear that GBT results are based on a beam theory while FSM results are based on a plate theory. In contrast to Example 1 a comparison using the GB-TUL software is not performed in this example as GB-TUL can not currently handle closed cross sections. The large deviation of 14.1% obtained by the presented GBT method can to a great extent be explained by the chosen constitutive relations in the current approach. Using identical simple non-coupling constitutive relations in the Abaqus finite element model the deviations now corresponds to (330 MPa) 0.0% and (941 MPa) 4.9%, respectively. Hereby reasonable matches between the two approaches are obtained for a rectangular hollow section, thus confirming that this new developed GBT approach provides adequate results with a very small computational cost, making it an alternative to the tradi-

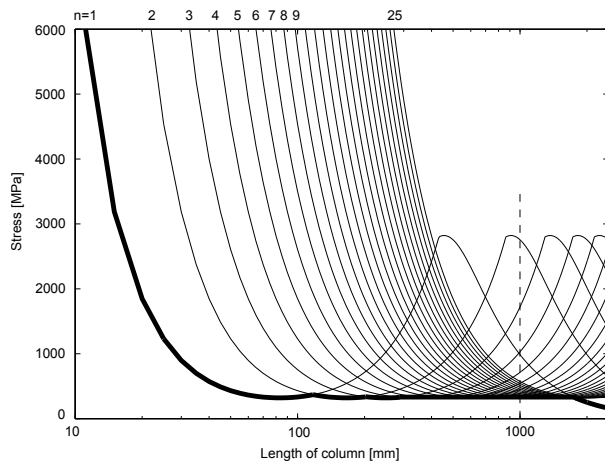

Figure 13: Buckling stress versus column length for the rectangular hollow section in compression.

tional and time consuming FE calculations and the other available methods. However there is a need to improve the constitutive assumptions related to the local plate behavior.

## 7. Conclusion

This paper presented the extension of the novel GBT approach developed by the authors in [15] and [16] to include the geometrical stiffness terms which are needed for column buckling analysis. The distortional differential equations developed in papers [15] and [16] are extended to a formulation including geometrical stiffness terms by using the initial stress approach to formulate the instability problem. The derived GBT differential equations with initial stress have been solved as an eigenvalue problem leading to a number of buckling modes and associated buckling stresses for simply supported columns in compression. Illustrative examples have been given dealing with a lipped channel column section and a rectangular hollow column section, respectively. In order to illustrate the application and validity of the approach the results have been compared with FE results obtained using the commercial program Abaqus as well as with FSM and conventional GBT results found using the freely available software packages CUFSM and GBTUL respectively. For both sections reasonable matches are obtained confirming that this new developed GBT approach including geometrical stiffness terms provides reasonable results with a very small computational cost making it an alternative to the traditional and time consuming FE calculations and the other available methods. However the constitutive relations

may have to be modified in order to achieve higher accuracy for local plate buckling.

## References

- [1] V.Z. Vlasov, *Thin-walled elastic beams*, 2nd ed. Israel Program for Scientific Translations, Jerusalem, Israel, 1961.
- [2] O.C. Zienkiewicz and R.L. Taylor, *The finite element method* 4th ed. Volume 1 – *Basic formulations and linear problems*. McGraw-Hill Book Company, UK, 1989.
- [3] T.J.R. Hughes, *The finite element method : Linear static and dynamic finite element analysis* Prentice-Hall, Inc., Englewood Cliffs, N.J, 2000.
- [4] J. Jönsson, S. Krenk and L. Damkilde. Recursive Substructuring of Finite Elements. *Computers & Structures*, 54, 395-404, 1995.
- [5] Y.K. Cheung, *Finite Strip Method in Structural Analysis* Pergamon Press, Oxford, 1976.
- [6] Y.K. Cheung and L.G. Tham, *The finite strip method* CRC Press, Boca Raton, 1998.
- [7] F.W. Williams and W.H. Wittrick, Computational procedures for a matrix analysis of the stability and vibrations of thin flat-walled structures in compression, *Int. J. of Mechanical Sciences*, 11, 979-798, 1968.
- [8] M. Loja and C.M. Mota Soares and C.A. Mota Soares. Modelling and design of adaptive structures using B-spline strip models. *Composite Structures*, 57(1-4), 245-251, 2002.
- [9] B.W. Schafer and S. Ádány, Modal decomposition for thin-walled member stability using the Finite Strip Method. *Advances in Engineering Structures, Mechanics and Construction*, Springer, 411-422, 2006.
- [10] R. Schardt, Anwendung der Erweiterten Technischen Biegetheorie auf die Berechnung prismatischer Falwerke und Zylinderschalen nach Theorie I. und II. Ordnung. Ordnung. *IASS-Symposium on Folded Plates and Prismatic Structures*, Vol. 1, Wien, 1970.
- [11] J.M. Davies and P. Leach, Second-order generalised beam theory. *J. Construct. Steel Research*, 31, 221-241, 1994.
- [12] J. Lepistö and S. Nikula and E. Niemi, Optimum design of cold-formed sections using Generalized Beam Theory. *Proceedings of the Second International Conference on Coupled Instabilities in Metal Structures*, (CIMS 1996 Lige, 05-07/09), J. Rondal and D. Dubina and V. Gioncu (eds.), Imperial College Press, London, 101-108.
- [13] P. Simão and L. Simões da Silva, Comparative analysis of the stability of open and closed thin-walled section members in the framework of Generalized Beam Theory. *EUROSTEEL – Proceedings of the 3rd European Conference on Steel Structures*, Vol. 1, Portugal, 2002.
- [14] D. Camotim and N. Silvestre and C. Basaglia and R. Bebiano (2008). GBT-based buckling analysis of thin-walled members with non-standard support conditions. *Thin-Walled Structures*, 46, 800-815, 2008.
- [15] Jönsson J. and M. J. Andreassen. Distortional eigenmodes and homogeneous solutions of semi-discretized thin-walled beams. *Thin-Walled Structures*, 49, 691-707, 2011.
- [16] M. J. Andreassen and J. Jönsson. Distortional solutions for loaded semi-discretized thin-walled beams. *Thin-Walled Structures in Press*.
- [17] C.F. Kollbrunner and N. Hajdin, *Dünnwandige Stäbe I, Stäbe mit undeformierbaren Querschnitten*. Springer-Verlag, Berlin, 1972, 1975.
- [18] J. Jönsson, Determination of shear stresses, warping functions and section properties of thin-walled beams using finite elements. *Computers & Structures*, 68, 393-410, 1998.



- [19] J. Jönsson, Distortional warping functions and shear distributions in thin-walled beams. *Thin-Walled Structures*, **33**, 245–268, 1999.
- [20] ABAQUS, *Theory manual v6.8 Simulia*, 2008.
- [21] Z. Li and B.W. Schafer, Buckling analysis of cold-formed steel members with general boundary conditions using CUFSM: conventional and constrained finite strip methods. *Proceedings of the 20th Int. Spec. Conf. on Cold-Formed Steel Structures*, St. Louis, MO. November, 2010.
- [22] R. Bebiano and P. Pina and N. Silvestre and D. Camotim, *GBTUL Buckling and Vibration Analysis of Thin-Walled Members*, DECivil/IST, Technical University of Lisbon (<http://www.civil.ist.utl.pt/gbt>), 2008.
- [23] J. Jönsson, Distortional theory of thin-walled beams. *Thin-Walled Structures*, **33**, 269–303, 1999.
- [24] S.P. Timoshenko and J.M. Gere, *Theory of elastic stability* McGraw-Hill, New York, 1961.
- [25] G. J. Hancock, Distortional buckling of steel storage rack column. *Journal of Structural Engineering*, Vol. 111, No. 12, 1985.