

Technical University of Denmark



Overview, status and outline of the new IEC 61400 -27 – Electrical simulation models for wind power generation

Sørensen, Poul Ejnar; Andresen, Björn; Fortmann, Jens; Johansen, Knud; Pourbeik, Pouyan

Published in:
Proceedings

Publication date:
2011

Document Version
Publisher's PDF, also known as Version of record

[Link back to DTU Orbit](#)

Citation (APA):

Sørensen, P. E., Andresen, B., Fortmann, J., Johansen, K., & Pourbeik, P. (2011). Overview, status and outline of the new IEC 61400 -27 – Electrical simulation models for wind power generation. In Proceedings

DTU Library

Technical Information Center of Denmark

General rights

Copyright and moral rights for the publications made accessible in the public portal are retained by the authors and/or other copyright owners and it is a condition of accessing publications that users recognise and abide by the legal requirements associated with these rights.

- Users may download and print one copy of any publication from the public portal for the purpose of private study or research.
- You may not further distribute the material or use it for any profit-making activity or commercial gain
- You may freely distribute the URL identifying the publication in the public portal

If you believe that this document breaches copyright please contact us providing details, and we will remove access to the work immediately and investigate your claim.

Overview, status and outline of the new IEC 61400 -27 – Electrical simulation models for wind power generation

Poul Sørensen, Björn Andresen, Jens Fortmann, Knud Johansen, Pouyan Pourbeik

Abstract-- This paper presents the ongoing work in Working Group (WG) 27 of IEC Technical Committee (TC) 88 developing a standard IEC 61400-27 for “Electrical simulation models for wind power generation”. The purpose of the standardization work is to define generic simulation models for wind turbines and wind power plants, which are intended for power system stability analyses. Thus, the models will be applicable for dynamic simulations of power system events such as faults, loss of generation or loads and switching of lines. The paper presents the actual status of the IEC TC88 WG27 work. Some of the challenges encountered during the process of the development of the standard are described, and expected outcome of the standard is also presented.

Index Terms—Electrical Simulation models, IEC standard, Wind turbine model, power system stability studies

I. INTRODUCTION

The increasing penetration of wind energy in power systems implies that Transmission System Operators (TSOs) and Distribution System Operators (DSOs) need to use dynamic models of wind power generation for power system stability studies. The models developed by the wind turbine manufacturers reproduce the behavior of their machines with a great level of accuracy and detail. Such level of detail is not suitable for stability studies of large power systems for two reasons. Firstly, the use of these models requires a substantial amount of input data to represent the individual wind turbine types some of which are occasionally considered proprietary data and hence make it difficult to publicly and widely distribute the models. Secondly, often these manufacturer specific models are either user written or object code that need to be compiled into the system model and so due to the complexity of the models incorporating large numbers of such models into continental wide power system models becomes a significant burden for the users.

II. PURPOSE

There exist today many grid codes from the Distribution- and Transmission system operators (DSO & TSO), many of these grid codes request a validated wind turbine model for their interconnection agreements. Due to the fact that there is no standard, neither for wind turbine models nor their validation, every manufacture has developed their own simulation model and validation procedure.

The purpose of IEC 61400-27 is to define standard, public dynamic simulation models for wind turbines and wind power plants, which are intended for use in large power

system and grid stability analyses, and should be applicable for dynamic simulations of power system events such as short circuits (low voltage ride through), loss of generation or loads, and typical switching events (e.g. line switching).

The Part 1 of the IEC 61400-27 series will specify wind turbine models and validation procedures. Part 2 will specify wind power plant models and validation procedures.

III. HISTORY OF IEC 61400-27

A. Members

From the beginning, there has been a high interest to participate in the standardisation work in WG27. At the first meeting in October 2009, 24 were appointed by their national standardisation committees. Currently, WG27 consists of 42 members from 16 countries (Austria, China, Denmark, France, Finland, Germany, Great Britain, Ireland, Japan, Korea, Netherlands, Norway, Russia, Spain, Sweden and USA). Besides the official members, several of the national committees also involve other people in discussing and commenting on the development.

The 42 members of WG27 represent all types of companies and organisations with a potentially high interest in the development and use of the standard. These can be grouped into grid operators (transmission and distribution), wind turbine manufacturers, sub suppliers, wind plant developers and owners, test and certification institutes, power system software companies, and the research and university community.

B. Meetings

WG27 will hold its 9th meeting in Beijing, in September 2011. Previously, meetings have been held in Denmark, Spain (2), USA (2), Germany, Finland and France. Although the meetings have required substantial amounts of travelling, and the attendance has been influenced by the location of the individual meeting, there has been a kernel of dedicated members who have made it possible to make progress in this difficult area for standardisation.

The first meeting focused on getting an overview of the models and validation practices that are used today. The next meeting was spent on development and agreement of a focus document, which details the scope and limitations of the models. This focus document established the basis for the working drafts.

It was agreed at an early stage that the models should only account for the fundamental frequency. It is common practice to base power system stability studies on fundamental frequency simulations only. In addition,

fundamental frequency models require much less data and are less computationally intensive than full 3-phase modelling.

A major issue of these discussions was on how to include the effect of unsymmetrical faults. Normally, only the positive sequence of the fundamental frequency is considered in stability studies, because the negative sequence is not expected to influence the stability. However, some wind turbines could trip due to the negative sequence in the event of unbalanced faults. Still, the first edition of IEC 61400-27 is not likely to include negative sequence models.

The meetings in 2010 have focused on the model validation procedure. This has been a challenge, because the common practice for validation is very different from one country to another. As an example, Germany has issued a very detailed guideline for validation, while USA essentially bases the validation on engineering judgement.

In order to make these differences meet, a smaller validation subgroup was established to compare the different approaches and eventually propose a procedure to be discussed in WG27. Some of the difficulties to define a fair and still informative procedure for validation are described further in the following modelling and validation sections.

The work on specification of models has ramped up in 2011. For this purpose, a new modelling subgroup was established. The modelling subgroup has a substantial overlap with the WECC renewable energy modelling working group, and it mainly consists of manufacturers because the aim is that the generic models should have a reasonable coverage of the actual wind turbines. EPRI also plays a key role in the modelling subgroup to support the merging of manufacturer specific models into generic models.

C. Time schedule towards a standard

The development of an IEC standard involves several stages. The first stage is to have the work approved by the national committees, which was done in April 2009. The second stage is for the working group (WG27) to prepare a (first) committee draft (CD) of the standard. Ideally, from the perspective of IEC, this stage should take only one year. The scope of WG27 is very complex, and therefore the CD stage is estimated to be finalised by the end of 2011. When the CD is submitted by WG27, the national committees must comment on it. WG27 should then compile the comments and decide if it will submit a committee draft for voting (CDV) to the national committees, or if another CD is needed. If the national committees vote yes for the CDV, then a final draft international standard is prepared. All together, this process is quite time consuming, so a printed standard for part 1 (wind turbines) is not expected to be available before mid 2013, and for part 2 (wind power plants) in early 2015.

IV. MODELLING OF WIND GENERATION SYSTEMS

As stated in the introduction, presently the IEC TC88 WG27 is focused on the development of wind turbine generator

(WTG) models. Detailed discussions on the aggregate wind power plant models have not yet started in-depth. This section summarises the current developments and discussions related to WTG models.

One section of the standard being developed is dedicated to a detailed outline of the scope and limitations of the standard WTG models being developed for stability analyses. Briefly, the models are to be used primarily for power system stability studies and thus should represent all dynamics affected and relevant during,

- short circuits (a/c electrical faults) on the transmission grid (external to the wind power plant, including voltage recovery),
- grid frequency disturbances (recommended +/- 6% from system nominal frequency),
- electromechanical modes of synchronous generator rotor oscillations (typically in the 0.2 to 4 Hz range), and
- set point changes in the WTG controls, such as step changes in voltage, reactive power and real power.

It should be fully realized that these models are not intended to capture dynamics outside of the above specified ranges (e.g. fast electromagnetic transients, etc.).

The modelling subgroup of the WG has reviewed and considered input from many sources including the first generation of generic models for WTG developed in the US [1], as well as publications from European researchers and vendors [2], [3], [4], to name a few.

With respect to the so-called type 1 (conventional induction generator WTG) and the type 2 (variable rotor-resistance induction generator WTG), there is reasonable agreement between the various approaches as presented in [1] and [4].

Figure 2 shows a high-level generic model structure which seems to apply to the type 1 and type 2 models proposed in [1] and [4], although the block and variable names have been adjusted.

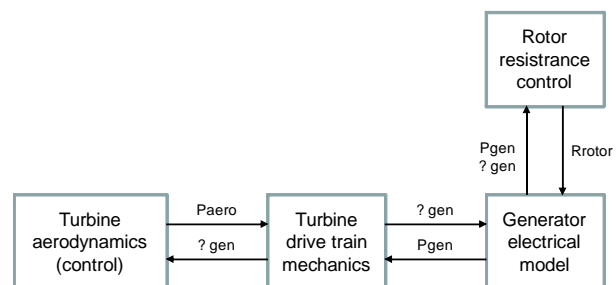

Figure 2: Model structure covering type 1 and type 2 WTGs. For the type 1 turbine, there is no controlled rotor resistance so that block essentially is eliminated.

The aerodynamics model depends on the turbine type. Most type 1 wind turbines have fixed pitch angle on the blades, and in that case the aerodynamic torque (but not power) can be assumed constant [4]. Type 2 and some type 1 turbines have pitch angle control, which are represented quite

similarly by “reduced” or “pseudo” models respectively in [1] and [2].

The drive train mechanical model (which is in [1] denoted “Wind Turbine Model”) is generally accepted to be a two-mass model including the stiffness between generator and wind turbine rotor.

The induction generator model includes the rotor flux transients but neglects the stator flux transients, which is common practice in power system stability studies.

The rotor resistance control block is only used for type 2. Type 1 turbines have constant rotor resistance.

The more complex and interesting models are those associated with the type 3 (doubly-fed asynchronous) and type 4 (full-converter) generators. Much of the dialogue and work presently in the modelling subgroup is around these models. Figure 3 shows a high-level diagram of the proposed model structure for the type 3 and 4 WTG. The actual models for the type 3 and type 4 WTG may be different from each other in the details of each of the specific blocks. As shown in the figure, the type 3 and 4 WTG has three major components:

1. the generator/converter model,
2. the electrical controls model, which defines the control of the active and reactive power of the unit, and
3. the model of the aerodynamics and drive-train, essentially the mechanical side of the unit.

For the type 4 WTG there is general agreement in the group that the generator/converter dynamics may be reduced to a simple small lag time constant. Given that the actual controls are orders of magnitude faster than the typical integration time-step of stability studies, much of the dynamics may be neglected as it is outside of the frequency band of interest. For example consider Figure 4. The figure shows the response of the reactive current output of a type 4 WTG to an imposed voltage-dip. For stability studies, the rather short duration and high-frequency transient “spikes” upon fault inception and clearing, which can be seen in the kilo-hertz sampled measurements (blue trace), are not of interest. Thus, the generic stability level model, which typically runs at an integration time step of $\frac{1}{4}$ to $\frac{1}{2}$ of a cycle, is tuned to capture the overall envelope of the current behaviour.

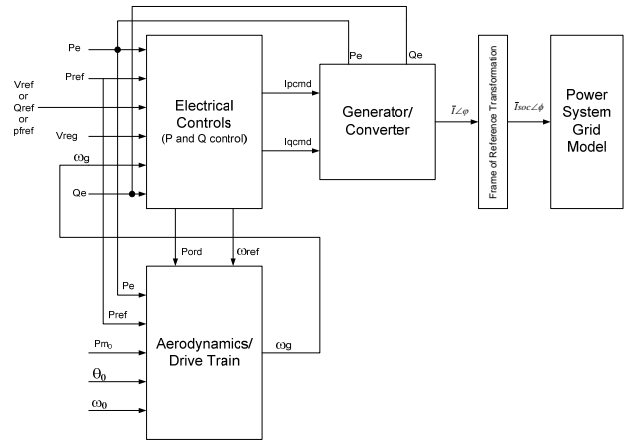

Figure 3: The generic WTG model structure.

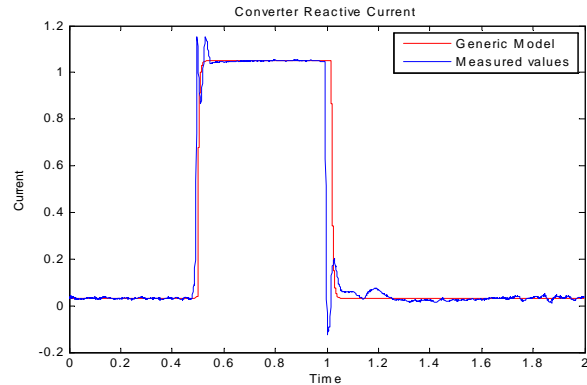

Figure 4: Reactive converter current for model versus measured response for a 3-phase voltage dip [5] (IEEE © 2011).

For the type 3 WTG there is presently discussion in the group to consider possibly modeling some of the dynamics associated with the electrical machines flux dynamics, in a rather simple way [2]. This is still under discussion and review.

For the electrical controls of the type 3 and type 4 WTG there is common agreement on the general structure of the controls. The controls are presently represented by simple proportional-integral control loops. There is, however, some discussion on the details of the emulation of ramp rates in the reactive and active power recover of the unit following grid faults.

For the drive-train a model has been proposed, based primarily on the model in [1]. There is general agreement in the group with respect to the two-mass model of the drive-train. As for the representation of the aerodynamic two simple models have been proposed, one based on [6], and another that is an extension of this simple representation which adds an offset and dependency on the speed and initial power. These additional features may allow for the type 3 WTG to consider some of the changing dynamics of the mechanical side as a function of initial wind speed. These aspects are still under discussion.

V. MODEL VALIDATION

The objectives of a validation process are to specify a procedure on how to validate the output of a wind turbine

simulation model in order to be compared with measured values from the wind turbine in concern.

In addition the results of a validation procedure could be applicable for quantifying the simulation model accuracy with the purpose of being applied in various grid stability evaluations and planning studies.

The validation procedure in the standard gives the preconditions to be fulfilled, the environmental set-up and the specifications for validation of an electrical simulation model. The validation procedures specified includes both balanced as well as unbalanced faults.

The simulation model validation tests include the following wind turbine functional characteristics:

- validation of the simulation modelling response to voltage drops,
- validation of the simulation modelling of the active power control functionality,
- validation of the simulation modelling of the reactive power control functionality, and
- validation of the simulated response of a grid protection functionality.

A. Validation requirements

The validation requirements being discussed are as briefly presented here.

The required validation tests for the three functional characteristics shall be referenced to the wind turbine terminals.

The required validation test set-up shall follow the generic structure as given in Figure 4.

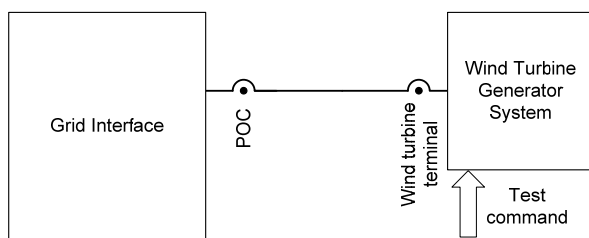

Figure 4: Generic test structure

To be compliant with this standard all required validation tests shall be performed and documented with the results from the validation procedures.

The result of the validation tests is to state or quantify the following characteristics of a simulation model:

- the errors between the measured and the simulated values, and
- to state the application range of the validated simulation model.

The simulation model validation is not intended to justify compliance to any grid code requirement, power quality or national legislation.

The measurements used for validation shall be based on the IEC 61400-21 specifications. All measurements shall be referenced to the wind turbine terminals as defined in IEC 61400-21, clause 3.22. All measured values specified shall be filtered, sampled, averaged and aggregated as specified in IEC 61400-21, clause 7.

A testing plan shall be compiled for every measurement used for validation.

Validation tests applying three phase faults for voltages drops and fault durations shall be validated by at least one measurement of each case specified in IEC 61400-21 in order to validate a simulation model. The same procedure shall apply for 2-phase faults inasmuch as they are demanded.

B. Compliance to the standard

To be compliant with this standard, the fundamental-frequency, positive-sequence response of the model shall be validated against the fundamental-frequency, positive-sequence response of the wind turbine from the test measurements. The tests and model response are for balanced and unbalanced voltage drops.

If a model simulates the negative sequence response of the wind turbine in addition to the positive-sequence response, then the simulated negative sequence response can be validated from the fundamental-frequency, negative-sequence response of the wind turbine from the test measurements. This pre-requires the submitting of the fundamental-frequency, negative-sequence test results. There is the need to still discuss some of these aspects within the IEC group given that the stability models are primarily positive sequence based.

The validation may be performed in one of two general approaches. In the first approach, one would model the wind turbine systems and also have an equivalent representation of the grid and the interface between the wind turbine and the grid. In the second approach (sometimes referred to as a 'play-back' approach) only the wind turbine system is modelled and one of the measured signals (typically voltage) is played-back into the model while the response of the other measured quantities (typically active and reactive current, and active and reactive power) of the wind turbine generator are validated against the simulated response of the model.

The measurements for use in the validation of the wind turbine simulation model are to be made at the terminals of the wind turbine generator system. According to IEC 61400-21 this point (the terminals of the wind turbine generator system - named as POC) is defined by the manufacturer and thus can be either (i) the low voltage side of the generator step-up transformer, or the (ii) high voltage side of the generator step-up transformer. These two different positions of the POC could have an impact on the validation test result as discussed in the standard, due to the behaviour of the transformer.

C. Error calculations

To provide a comparison of measured values and simulated values, an evaluation of the deviation between the simulated values will need to be performed. This is discussed in more detail in the actual standard document being developed.

It must be understood that any measurement process has associated errors. The cumulative effect of such errors can easily fall in the range of several percent, this is discussed in more detail in an annex of the standard. As such, one must be cognizant of these facts and not require a match between measurement and simulation that is unreasonable.

VI. SUMMARY AND OUTLINE

This paper presents an overview of the continuing work of the IEC TC 88 WG27 working group. The considerations and challenges during the development of the standard are discussed. Dynamic models used for power system stability simulations are derived after significant simplifications of actual equipment controls and physics, for it is neither practical nor appropriate to achieve perfect representation of all dynamics (e.g. down to electromagnetic transients level). There is a compromise, and significant challenge, between achieving models that adequately represent dynamics in the frequency range of interest for stability studies, while not making the models and model validation overly complex.

The validation will be based on the measurements described in IEC 61400-21.

The working group expects to have the first Committee draft (CD) ready by the end of 2011.

The work on the part II will start directly after the submission of the part I and will specify dynamic simulation models for generic power plant topologies/configurations including wind power plant control and auxiliary equipment. This part will also specify methods to create models for future wind power plant configurations.

There exist today no test or measurement procedure for wind power plants, the validation procedure in part II of the standard will define some validation procedures and the WG 27 will work closely together with the MT 21 to define measurement procedures for Wind Power Plants in a new revision of this standard.

VII. REFERENCES

- [1] A. Ellis, Y. Kazachkov, E. Muljadi, P. Pourbeik and J. Sanchez-Gasca, "Description and Technical Specifications for Generic WTG Models – a status report", Proceedings of the 2011 IEEE PES PSCE, March 2011, Phoenix, Arizona, USA.
- [2] J. Fortmann, S. Engelhardt, J. Kretschmann, C. Feltes, M. Janssen, T. Neumann and I. Erlich, "Generic Simulation Model for DFIG and Full Scale Converter based Wind Turbines", Proceedings of the 9th International Workshop on Large-Scale Integration of Wind Power, Quebec/Canada, October 2010.
- [3] S. Seman, J. Simolin, J.-P. Matsinen, J. Niiranen, "Validation of Type 4 Wind Turbine Generic Simulation Model by Full-Scale Test", Proceedings of the 9th International Workshop on Large-Scale Integration of Wind Power, Quebec/Canada, October 2010.
- [4] V. Akhmatov, "IEC Type 1 and Type 2 Generic Wind Turbine Models: Draft 01", December, 2010.

- [5] Asmine, M.; Brochu, J.; Fortmann, J.; Gagnon, R.; Kazachkov, Y.; Langlois, C. E.; Larose, C.; Muljadi, E.; MacDowell, J.; Pourbeik, P.; Seman, S. A.; Wiens, K., "Model Validation for Wind Turbine Generator Models", IEEE Transactions on PWRs, Aug. 2011, pages: 1769 – 1782.
- [6] W. W. Price and J. J. Sanchez-Gasca, "Simplified Wind Turbine Generator Aerodynamic Models for Transient Stability Studies", Proceedings of the IEEE PSCE 2006.

VIII. APPENDIX

The following is a list of the variables shown in Figure 3.

Ipcmd	active power command
Iqcmd	reactive power command
$\bar{I}\angle\phi$	Injected current from the WTG
$\bar{I}_{soc}\angle\phi$	Injected current from the WTG transformer to the grid reference frame
Pe	electrical real power injected by the WTG into the grid (+ve value means power going from WTG into the grid)
pfref	reference power factor
Pm ₀	Initial mechanical power output – determined during model initialization
Pord	real power order
Pref	Real power reference
Qe	electrical reactive power injected by the WTG into the grid (+ve value means power going from the WTG into the grid)
Qref	reactive power reference
Vt	terminal voltage of the WTG
Vreg	voltage that is being regulated by the WTG electrical controls (may be different to Vt)
ω_g	speed of the generator
ω_{ref}	speed reference (i.e., the current speed reference for the turbine, which is determined by a user-defined lookup table that defines speed versus power output)
ω_0	Initial speed – determined during model initialization
θ_0	Initial "pitch" angle – determined during model initialization

IX. ACKNOWLEDGMENT

The authors gratefully acknowledge the contributions of the IEC TC88 WG27 members to the Working draft of the Standard and there contribution to this article.

X. BIOGRAPHIES



Poul Sørensen received his M.Sc. EE from the Technical University of Denmark in 1987. In 1987, he has been employed in the Wind Energy Division at Risø National Laboratory, Roskilde, Denmark, and in 2008, he was appointed professor in Risø DTU – Technical University of Denmark. His main research interest is integration of wind power into power systems, involving a variety of disciplines including dynamic modeling and control of wind turbines and wind farms, power system

control and stability, and wind power fluctuations. He is convener of IEC TC88 WG27. He is Editor on Wiley journal Wind Energy.



Björn Andresen, received his B.Sc. from Kiel in Germany in 1996, his M.Sc. EE in 1998 from Aalborg University in Denmark, and his EBA from Vitus Bering University College in 2009. From 1998 to 2003 he worked at Vestas Wind Systems, latest as head of the power control group. From 2003 to 2008 he has been working at Gamesa Wind Engineering as Section Manager for the electrical department in Silkeborg, furthermore he was the manager of the power converter group in the Gamesa R&D department in Spain.

Since December 2008 he works for Siemens Wind Power as Head of department – Wind Farm electrical Interface. The Department provides the overall electrical interface to SWP wind turbines and related systems. This means the design, implementation and technical support in terms of power - , communication - and control systems.

He is a member of several national and international standard committees for Converter design and grid connection of Wind turbines.

and 1997, respectively. From 1997 to 2000 he was with GE Power Systems. From 2000 to 2006 he was with ABB Inc. In June 2006 he joined EPRI. Throughout his career he has been involved in the modelling and analysis of dynamic and system technical performance of power systems. He presently serves as the secretary of both the IEEE PES Power System Dynamic Performance Committee and CIGRE Study Committee C4 – System Technical Performance. He also presently serves as the chairman of the IEEE Dynamic Performance of Wind Generation Working Group. He is also a member of numerous US and international working groups dealing with various aspects of power system modelling. He is a registered professional engineer in the state of North Carolina, USA, and a Fellow of the IEEE.



Jens Fortmann (1966) received his Dipl.-Ing. degree in electrical engineering from the Technical University Berlin, Germany, in 1996. From 1995 to 2002 he worked on the simulation of the electrical system and the control design of variable speed wind turbines at the German wind turbine manufacturers Suedwind and Nordex Energy. Since 2002 he is with RE-power Systems AG, Germany presently as team leader of model and system development for the simulation and implementation of new technologies for improved grid compatibility of wind turbines like voltage control and ride-through of grid faults. He is currently the head of the FGW working group that specifies the model validation guideline TR4



Knud Johansen received his B.Sc. E.E from Technical College, Aarhus, Denmark in 1975 and his M.Sc. from Technical University of Denmark in 1979. With a long track record in several industrial areas in Europe he joined the Smart Grid team in Energinet.dk in 2009. His primary focus is on grid code aspects for renewable energy devices, especially wind and solar based generation units. Since 2000 he has been involved in developing the IEC 61400-25 and the IEC 61400-26 series of standards for wind power under the scope of IEC TC88 as well as standards for communication (IEC 61850 standard series) and security (IEC 62351 standard series) aspects under the scope of IEC TC57. In addition he serves as chairman for the Danish national mirror group for IEC TC57.



Pouyan Pourbeik received his BE and PhD in Electrical Engineering from the University of Adelaide, Australia in 1993