

Technical University of Denmark



Engineering Rules for Optical Generation and Detection of High Speed Wireless Millimeter-wave Band Signals

Caballero Jambrina, Antonio; Zibar, Darko; Sambaraju, Rakesh; Guerrero Gonzalez, Neil; Tafur Monroy, Idelfonso

Published in:

Proceedings of the European Conference on Optical Communication (ECOC) 2011

Publication date:

2011

Document Version

Publisher's PDF, also known as Version of record

[Link back to DTU Orbit](#)

Citation (APA):

Caballero Jambrina, A., Zibar, D., Sambaraju, R., Guerrero Gonzalez, N., & Tafur Monroy, I. (2011). Engineering Rules for Optical Generation and Detection of High Speed Wireless Millimeter-wave Band Signals. In Proceedings of the European Conference on Optical Communication (ECOC) 2011 (pp. We.10.P1). Optical Society of America.

DTU Library

Technical Information Center of Denmark

General rights

Copyright and moral rights for the publications made accessible in the public portal are retained by the authors and/or other copyright owners and it is a condition of accessing publications that users recognise and abide by the legal requirements associated with these rights.

- Users may download and print one copy of any publication from the public portal for the purpose of private study or research.
- You may not further distribute the material or use it for any profit-making activity or commercial gain
- You may freely distribute the URL identifying the publication in the public portal

If you believe that this document breaches copyright please contact us providing details, and we will remove access to the work immediately and investigate your claim.

Engineering Rules for Optical Generation and Detection of High Speed Wireless Millimeter-wave Band Signals

Antonio Caballero¹, Darko Zibar¹, Rakesh Sambaraju^{2,*} Neil Guerrero Gonzalez¹
and Idelfonso Tafur Monroy¹

1. DTU Fotonik, Department of Photonics Engineering, Technical University of Denmark, Ørstedss Plads, B. 343, DK 2800 Kgs. Lyngby
email:acaj@fotonik.dtu.dk

2. Universidad Politecnica de Valencia, Camino de Vera S/N, Valencia 46022, Spain. *Currently at Corning Inc., Corning, N.Y, 14831 USA.

Abstract: We analyze the design requirements for 40 Gbit/s wireless generation and detection in the millimeter-wave band, combining baseband optical I/Q modulation and coherent detection with wireless optical heterodyning generation and single-side band electro-optical modulation.

OCIS codes: (060.1660) Coherent communications; (120.5060) Phase modulation; (060.5625) Radio frequency photonics

1. Introduction

Photonics methods for the generation and detection of high speed wireless signals are gaining much attention due to the high capacity that optics can provide [1-3]. The use of high carrier frequencies, such as in the 75 GHz – 110 GHz band, could potentially provide very high capacity wireless links as there are several GHz of available bandwidth. Recently the use of the baseband optics for the generation and detection of high speed microwave signals in the 100 GHz band has been demonstrated to enable over 32 Gbit/s and high spectral efficient modulation formats [2]. The key technologies are, at the transmitter side, the use of advance modulation formats (QPSK, m-QAM) for the generation of high capacity and spectral efficient baseband optical signals. At the receiver side, the use of coherent detection assisted with digital signal processing (DSP) enables the compensation of link impairments, such as laser beating, filtering, etc. Based on the robustness of the receiver, the generation of the microwave signal can be realized by optical heterodyning the optical signal with a second laser source. In the reception, the microwave signal is re-modulated in the optical domain. By optical filtering the side-band generated, the signal is converted back to baseband, where standard coherent detection is applied for demodulation.

In this paper we evaluate the performance of the optical components for the generation and detection of microwave signals to establish the engineering rules for the link design. We have evaluated the performance for 10 Gbaud QPSK and 16QAM for a maximum bitrate of 40 Gbit/s at 100 GHz RF carrier frequency. We have studied the influence of the linewidth of the lasers, optical signal-to-noise ratio (OSNR), response of the transmitter photodiode, linearity of the optical modulator, as well as electrical amplifier non-linear distortion.

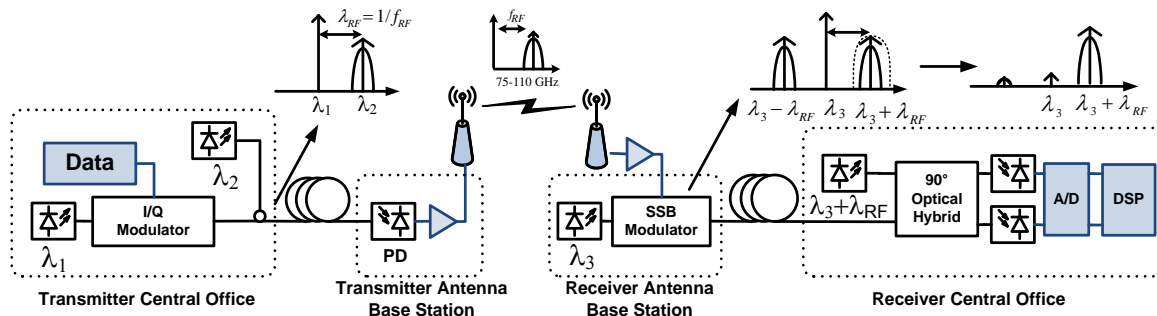

Fig. 1 Experimental set-up for generation and detection of optical generated wireless signal for millimeter frequency band.

2. Principle of optical transparent generation and detection of wireless signals

The block diagram of optical transparent generation and detection of wireless signal is shown in Fig. 1. At the transmitter central office (CO), an optical I/Q modulator is used to generate a high bitrate baseband signal centered at λ_1 . This signal transported to the Antenna Base Station (BS) together with a second continuous wave laser source at a wavelength λ_2 . The beating of the two optical signals at the photodiode in the BS creates an electrical signal at the frequency defined by the difference of the two wavelengths of the lasers. The received wireless signal is optically modulated using a high speed Electro-Absorption Modulator (EAM) or Mach-Zehnder Modulator (MZM). The optical side-band containing the information is narrow filtered, to create Single-Side Band (SSB) architecture. This signal is transmitted to the CO and detected using coherent detection and DSP.

The performance of the system in the generation and especially in the detection is degraded due to impairments in the optical and electrical domain. From the optical domain, the beating of the four lasers in the system results in

stringent requirements on the linewidth of the lasers, increasing also the complexity of the DSP carrier-phase recovery. Secondly, the photodiode at the transmitter antenna can induce distortion in the generation of the wireless signal, by the non flat response at high microwave frequencies. It should also be capable to support high optical power, so transmitter RF amplifier can be removed. Thirdly, single-side band modulation of the optical signal at high carrier frequency results in a low electro-optical efficiency, requiring high optical amplification and as a result low OSNR. The modulator design should be optimized to improve modulation index and have also a flat response in the microwave band. From the electrical domain, the wireless link losses can be tremendous, requiring a low-noise linear RF amplifier after the receiver antenna, which is very challenging with current technology.

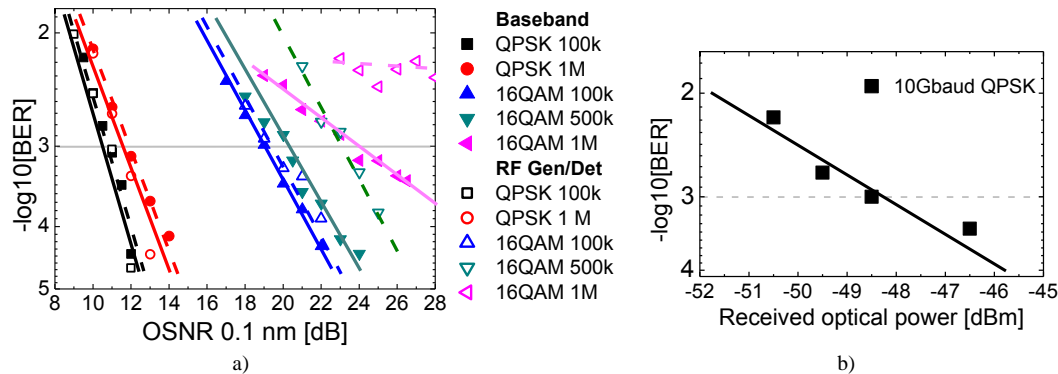

Fig.2 a) BER performance as a function of OSNR for back-to-back baseband coherent detection and transparent generation and detection of RF signals in the 100 GHz band for different laser linewidths. b) Experimental results of receiver sensitivity prior amplification of a 10 Gbaud QPSK at 100 GHz RF frequency link with 100 kHz linewidth lasers.

3. Requirements for the detection of the optically generated wireless signal

The system described in the previous section has been simulated using Matlab and VPI transmission maker based on the experiments from [2,3]. A single carrier QPSK and 16QAM system has been simulated at 10 Gbaud for 100 GHz RF frequency generation and detection. The algorithms of the demodulation consist on Constant-Modulus Algorithm (CMA) blind equalization, decision-based carrier-phase recovery and symbol mapping [2,4]. In Fig. 2 are shown the BER results as a function of OSNR and linewidth for QPSK and 16QAM. OSNR of 11 dB is required to achieve BER below 10^{-3} , with only 1 dB penalty from 100 kHz to 1 MHz linewidth lasers and no penalty from Back-to-Back (B2B) baseband detection to RF generation and detection. For 16QAM modulation format, 100 kHz linewidth lasers requires an OSNR of 19 dB for both cases. For 500 kHz linewidth lasers 3 dB higher OSNR is required for RF generation and detection. For 1 MHz linewidth lasers the performance shows an error floor due to the failure of the carrier-phase recovery algorithm to track the fast phase drifts of the lasers. In the experimental validation demonstrated in [2], shown in Fig. 2b) for 10 Gbaud QPSK with 100 kHz linewidth lasers, the experimental BER results are plotted with respect to the optical power of the SSB received signal. The maximum experimental received power was -46.5 dBm with +10 dBm RF power to the modulator, meaning low modulation efficiency. To increase the received optical power, pass-band design of the modulator, matched for 100 GHz band, as well as a higher maximum optical power into modulator will be required.

4. Evaluation of the linearity of the Single-Side Band modulator

The performance of the system has been evaluated for two different modulators, EAM and MZM to perform the optical modulation of the detected microwave signal. The approach used in [2] is an EAM, which has high modulation bandwidth (>80 GHz). Both modulators have been simulated and the performance has been evaluated for different modulation indexes (MI). Fig. 3 shows their performance for QPSK and 16QAM at an OSNR of 11 dB and 20 dB respectively (BER $\sim 10^{-3}$) for the case of MZM 3a) and EAM Fig. 3b). A MZM shows a constant degradation for high MI, being more severe for 16QAM. For the EAM, an abrupt distortion is shown once the microwave signal enters in the saturation of the EAM. The use EAM is the only possible solution based on the current technology to achieve higher bandwidths. However, if the progression of MZM technology scales towards millimeter wave, it would be the preferred option due to higher linearity for low MI and higher maximum optical power capacity [6]. In Fig. 3 c) it is shown the influence of the photodiode filtering at the transmitter antenna station based on n-order Butterworth. The influence of high order filtering degrades the signal generation, when equivalent filtering order is over 3 (18 dB per octave). Thus, match design of the photodiode for millimeter wave frequencies is required for the generation of high capacity wireless signals.

To test the performance in terms of linearity of the RF amplifier prior the SSB modulation, we have simulated a 3rd order non-linear distortion amplifier model, quantified in terms of Interception Point of 3rd order (IP3). The

penalty of the amplifier for low IP3-to-RF signal power ratio is higher for 16QAM, with negligible difference for QPSK. This is due to the constant modulus of QPSK, which is less non-linear sensitive than 16QAM, and the CMA blind equalization capabilities. The distortion of the wireless 16QAM signal, due to this non-linearities results in non-squared constellation shape, especially significant in the outer symbols, which can be seen in fig. 3 f). To improve the performance in terms of BER, a modified decision algorithm based on k-means has been applied [5]. The algorithm consists on recursive adaptation of the 16QAM centroids from the statistics of the received symbols. In Fig. 3 e) is shown the advantage of k-means algorithm for the detection of high distorted RF signals, with an improvement of 1 dB for BER of 10^{-3} and 1.6 dB for $2 \cdot 10^{-3}$.

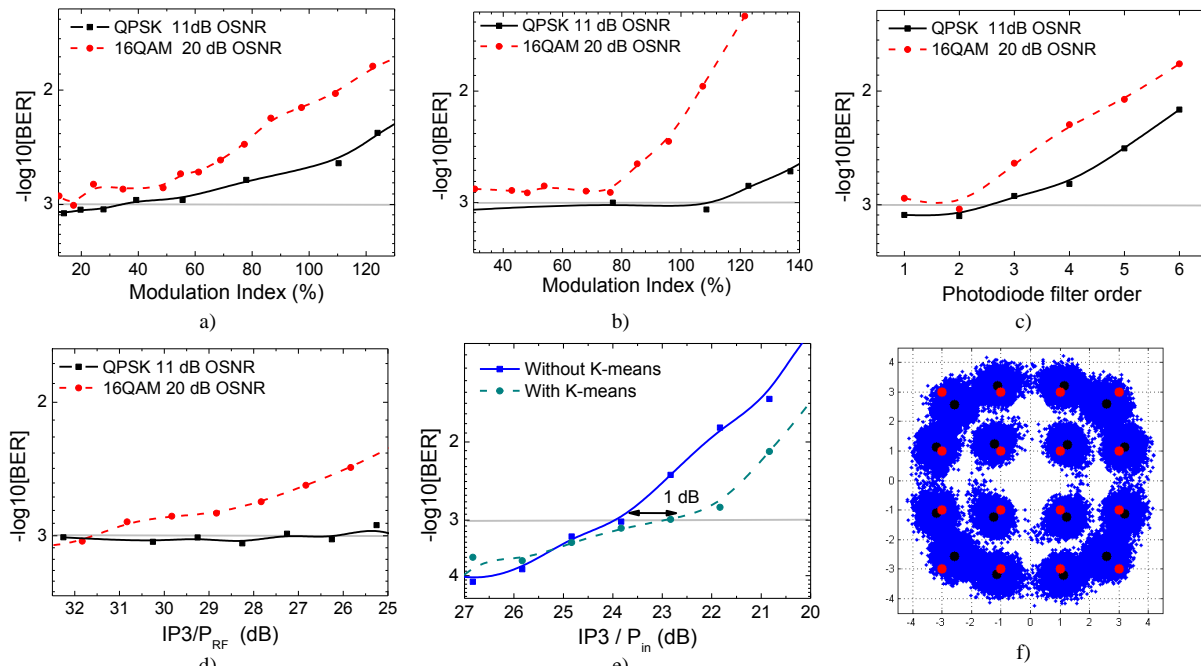

Fig.3 a) BER performance for MZM SSB modulation for different modulation indexes, b) EAM for SSB .c) BER penalty for different transmitted photodiode filter function, d) for different IP3 values of the pre-amplifier at the RX antenna station, e) k-means performance for 16QAM decision, f) constellation of 23 dB IP3/Pin including the original decision centroids (red) and after k-means (black).

5. Conclusions

We have analyzed the requirements for the generation and detection of high speed wireless signals using optics. We have studied the requirements for the design and implementation of a 100 GHz wireless system for the generation a detection of up to 40 Gbit/s high-order modulation format signals (QPSK and 16QAM) using optics. The results show the feasibility of the system for achieving high bitrates wireless transmission, but limitations of the electrical and optical components, such as photodiode, modulators and lasers, will decrease the performance of this type of systems, especially when wireless transmission would be implemented. Towards real-time implementation, this architecture could use the receivers developed for real-time coherent baseband, with minor adaptation, as standard baseband algorithms have been applied for the demodulation of the detected microwave signals.

Acknowledgment

This work has been supported by the European Commission FP7 under Network of Excellence project EUROFOS. The authors acknowledge Urban Westergren of the project ICT-HECTO.

References

- [1] A. Stöhr, '10 Gbit/s Wireless Transmission Using Millimeter-Wave over Optical Fiber Systems' OFC'11, OTuO3, 2011
- [2] R. Sambaraju et al., '100-GHz Wireless-Over-Fiber Links With Up to 16-Gb/s QPSK Modulation Using Optical Heterodyne Generation and Digital Coherent Detection' IEEE PTL, vol.22, no.22, pp.1650-1652, 2010
- [3] R. Sambaraju et al., '16 Gb/s QPSK Wireless-over-Fiber Link in 75-110 GHz Band with Photonic Generation and Coherent Detection' MWP'10 PDP 1, 2010
- [4] A. Caballero et al., 'Digital coherent detection of multi-gigabit 16-QAM signals at 40 GHz carrier frequency using photonic downconversion', ECOC'09, PDP 3.4, 2009
- [5] N. Guerrero Gonzalez et al., 'Reconfigurable digital receiver for 8PSK subcarrier multiplexed and 16QAM single carrier phase-modulated radio over fiber links'. IEEE MOTL, vol. 22, issue. 5, pp. 335-337, 2010
- [6] C. Cox, *Analog optical links, theory and practice*, (Cambridge University Press, 2004), Chap. 2